

## **Certification Test Report**

**FCC ID: SDBIDTB001  
IC: 2220A-IDTB1**

**FCC Rule Part: CFR 47 Part 24 Subpart D, Part 90 Subpart I, Part 101  
Subpart C  
IC Radio Standards Specification: RSS 119, RSS 134**

**ACS Report Number: 10-0432.W04.11.A**

Applicant: Sensus Metering Systems  
Model: IDTB001

Test Begin Date: February 4, 2011  
Test End Date: February 4, 2011

Report Issue Date: February 8, 2011



FOR THE SCOPE OF ACCREDITATION UNDER LAB Code 200612-0

This report must not be used by the client to claim product certification, approval, or endorsement by NVLAP, NIST, or any agency of the Federal Government.

Reviewed by: \_\_\_\_\_

**Kirby Munroe  
Director, Wireless Certifications  
ACS, Inc.**

This test report shall not be reproduced except in full. This report may be reproduced in part with prior written consent of ACS, Inc. The results contained in this report are representative of the sample(s) submitted for evaluation.

**This report contains 13 pages**

# Table of Contents

---

<b>1.0 GENERAL</b>	3
1.1 Purpose	3
1.2 Product Description	3
1.3 Test Methodology	3
1.3.1 Test Configurations and Justification	3
1.3.2 In-Band Testing Methodology	4
1.4 Emission Designators	4
<b>2.0 GENERAL</b>	5
2.1 Location	5
2.2 Laboratory Accreditations/Recognitions/Certifications	5
2.3 Radiated Emissions Test Site Description	6
2.3.1 Semi-Anechoic Chamber Test Site	6
2.3.2 Open Area Tests Site (OATS)	7
<b>3.0 APPLICABLE STANDARD REFERENCES</b>	8
<b>4.0 LIST OF TEST EQUIPMENT</b>	8
<b>5.0 SUPPORT EQUIPMENT</b>	9
<b>6.0 EQUIPMENT UNDER TEST SETUP AND BLOCK DIAGRAM</b>	9
<b>7.0 SUMMARY OF TESTS</b>	10
7.1 Occupied Bandwidth (Emission Limits)	10
7.1.1 Measurement Procedure	10
7.1.2 Measurement Results	10
<b>8.0 CONCLUSION</b>	13

## **1.0 GENERAL**

### **1.1 Purpose**

The purpose of this report is to demonstrate compliance with CFR 47 Part 24 Subpart D, Part 90 Subpart I, and Part 101 Subpart C of the FCC's Code of Federal Regulations; and RSS 119 and 134 of Industry Canada's Radio Standard Specifications for a Class II Permissive Change.

The purpose of this Class II Permissive Change is to add a new modulation format/mode.

### **1.2 Product Description**

The IDTB001 Sensus Integrated Display Transceiver is a printed circuit board that provides wireless communication capability to electric utility meters. The device mounts into existing iCon meters and acts as the "Integrated Communications Device". The device monitors meter reading and diagnostic information via an interface to the Sensus Sensor board and communicates via the Sensus fixed wireless telemetry network to provide electric meter readings and diagnostic data from the meter to the utility provider via a two-way radio link. The device also contains an LCD display allowing on-site visual meter reading to be accomplished.

Manufacturer Information:  
Sensus Metering Systems, Inc.  
400 Perimeter Park Drive, Suite K  
Morrisville, NC 27560

Test Sample Serial Numbers: 100519039382994

Operating Voltage: 26VDC

Test Sample Condition: The test samples were provided in good working order with no visible defects.

### **1.3 Test Methodology**

#### **1.3.1 Test Configurations and Justification**

For RF conducted measurements, the IDTB001 was modified with an external RF connector to the PCB. The IDTB001 utilizes a non-detachable antenna for normal operation but for RF conducted testing the antennas were disconnected and a 50-Ohm test cable soldered (with the appropriate ground connection) to the PCB.

The IDTB001 operates using various modulation formats/modes. Only a single modulation format/mode was evaluated for the purpose of this report. All other formats/modes have been evaluated under existing equipment authorizations and approvals.

The additional modulation format/mode was evaluated in full only for occupied bandwidth (emission mask) compliance. All other characteristics such as output power, spurious emissions at the antenna port, radiated emissions, and frequency stability were unaffected by the additional format/mode and therefore not reported.

**1.3.2 In-Band Testing Methodology**

For testing in accordance with 47 CFR 2.1046-2.1057, OET/Lab recommends that the following be used to select test frequencies for licensed devices:

Frequency range over which device operates	Number of frequencies	Location in the range of operation
1 MHz or less	1	Middle
1 to 10 MHz	2	1 near top and 1 near bottom
10 to 100 MHz	3	1 near top, 1 near middle and 1 near bottom

The IDTB001 module is designed to operate in multiple bands under the requirements of CFR 47 Parts 24, 90, and 101. The following is a list of the frequency bands of operation sorted based on the FCC rule parts in which the band is associated.

CFR Title 47 Rule Part	Frequency Band of Operation (MHz)
24D	901.0 - 902.0
24D	930.0 - 931.0
24D	940.0 - 941.0
90	896.0 - 901.0
90	935.0 - 940.0
101	928.85 - 929.0
101	932.0 - 932.5
101	941.0 - 941.5
101	959.85 - 960.0

The additional modulation format/mode can only operate in the frequency bands highlighted above (base bands) therefore only data presenting those frequency bands are provided in this report.

**1.4 Emission Designators**

The IDTB001 transceiver produces (7) distinct modulation formats. The emissions designators for the (7) modulation types used by the IDTB001 transceiver are as follows:

**EMISSIONS DESIGNATORS:**

- Normal Mode: 9K60F2D (7-FSK)
- Double Density Mode: 9K60F2D (13-FSK)
- C&I Mode: 4K80F2D (7-FSK)
- Priority Mode: 4K80F2D (13-FSK)
- Boost Mode: 1K10F2D (7-FSK)
- MPass Mode (5kbps): 5K90F1D (2-GFSK)
- MPass Mode (10kbps): 11K8F1D (2-GFSK)\***

\*Note: MPass Mode (10kbps), 11K8F1D (2-GFSK), is the format/mode addressed in this report. All other formats/modes have been evaluated under existing equipment authorizations and approvals.

## **2.0 GENERAL**

### **2.1 Location**

The radiated and conducted emissions test sites are located at the following address:

Advanced Compliance Solutions  
5015 B.U. Bowman Drive  
Buford, GA 30518  
Phone: (770) 831-8048  
Fax: (770) 831-8598

### **2.2 Laboratory Accreditations/Recognitions/Certifications**

ACS is accredited to ISO/IEC 17025 by the National Institute of Standards and Technology under their National Voluntary Laboratory Accreditation Program (NVLAP), Lab Code 200612-0. Unless otherwise specified, all tests methods described within this report are covered under the ISO/IEC 17025 scope of accreditation.

The Semi-Anechoic Chamber Test Site, Open Area Test Site (OATS) and Conducted Emissions Site have been fully described, submitted to, and accepted by the FCC, Industry Canada and the Japanese Voluntary Control Council for Interference by information technology equipment.

FCC Registration Number: 894540

Industry Canada Lab Code: IC 4175A-1

VCCI Member Number: 1831

- VCCI OATS Registration Number R-1526
- VCCI Conducted Emissions Site Registration Number: C-1608

**2.3 Radiated Emissions Test Site Description**

**2.3.1 Semi-Anechoic Chamber Test Site**

The Semi-Anechoic Chamber Test Site consists of a 20' x 30' x 18' shielded enclosure. The chamber is lined with Toyo Ferrite Grid Absorber, model number FFG-1000. The ferrite tile grid is 101 x 101 x 19mm thick and weighs approximately 550 grams. These tiles are mounted on steel panels and installed directly on the inner walls of the chamber.

The turntable is 150cm in diameter and is located 160cm from the back wall of the chamber. The chamber is grounded via 1 - 8' copper ground rod, installed at the center of the back wall, it is bound to the ground plane using 3/4" stainless steel braided cable.

The turntable is all steel, flush mounted table installed in an all steel frame. The table is remotely operated from inside the control room located 25' from the range. The turntable is electrically bonded to the surrounding ground plane via steel fingers installed on the edge of the turn table. The steel fingers make constant contact with the ground plane during operation.

Behind the turntable is a 3' x 6' x 4' deep shielded pit used for support equipment if necessary. The pit is equipped with 1 - 4" PVC chases from the turntable to the pit that allow for cabling to the EUT if necessary. The underside of the turntable can be accessed from the pit so cables can be supplied to the EUT from the pit.

A diagram of the Semi-Anechoic Chamber Test Site is shown in Figure 2.3-1 below:

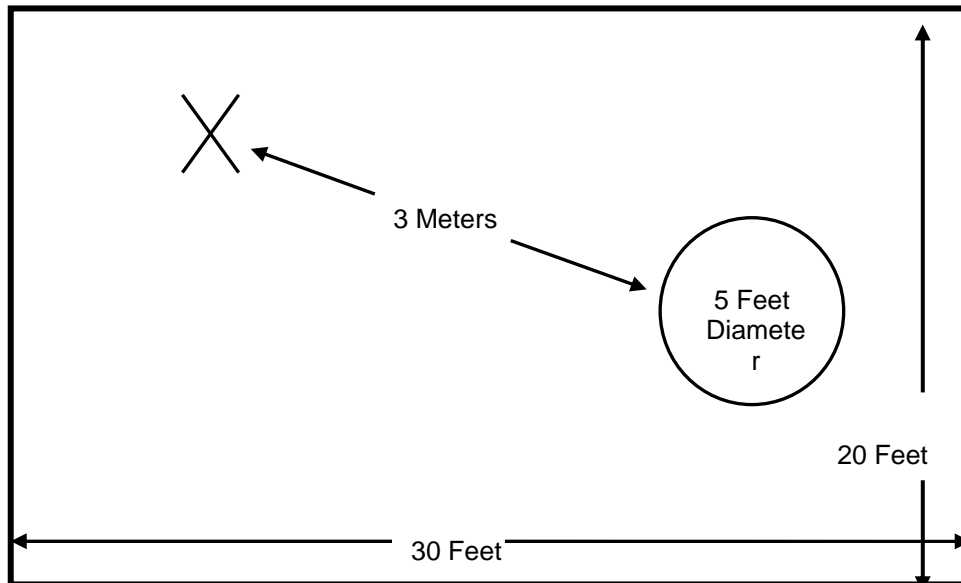

**Figure 2.3-1: Semi-Anechoic Chamber Test Site**

**2.3.2 Open Area Tests Site (OATS)**

The open area test site consists of a 40' x 66' concrete pad covered with a perforated electro-plated galvanized sheet metal. The perforations in the sheet metal are 1/8" holes that are staggered every 3/16". The individual sheets are placed to overlap each other by 1/4" and are riveted together to provide a continuous seam. Rivets are spaced every 3" in a 3 x 20 meter perimeter around the antenna mast and EUT area. Rivets in the remaining area are spaced as necessary to properly secure the ground plane and maintain the electrical continuity.

The entire ground plane extends 12' beyond the turntable edge and 16' beyond the antenna mast when set to a 10 meter measurement distance. The ground plane is grounded via 4 - 8' copper ground rods, each installed at a corner of the ground plane and bound to the ground plane using 3/4" stainless steel braided cable.

The turntable is an all aluminum 10' flush mounted table installed in an all aluminum frame. The table is remotely operated from inside the control room located 40' from the range. The turntable is electrically bonded to the surrounding ground plane via steel fingers installed on the edge of the turn table. The steel fingers make constant contact with the ground plane during operation.

Adjacent to the turntable is a 7' x 7' square and 4' deep concrete pit used for support equipment if necessary. The pit is equipped with 5 - 4" PVC chases from the pit to the control room that allow for cabling to the EUT if necessary. The underside of the turntable can be accessed from the pit so cables can be supplied to the EUT from the pit. The pit is covered with 2 sheets of 1/4" diamond style re-enforced steel sheets. The sheets are painted to match the perforated steel ground plane; however the underside edges have been masked off to maintain the electrical continuity of the ground plane. All reflecting objects are located outside of the ellipse defined in ANSI C63.4.

A diagram of the Open Area Test Site is shown in Figure 2.3-2 below:

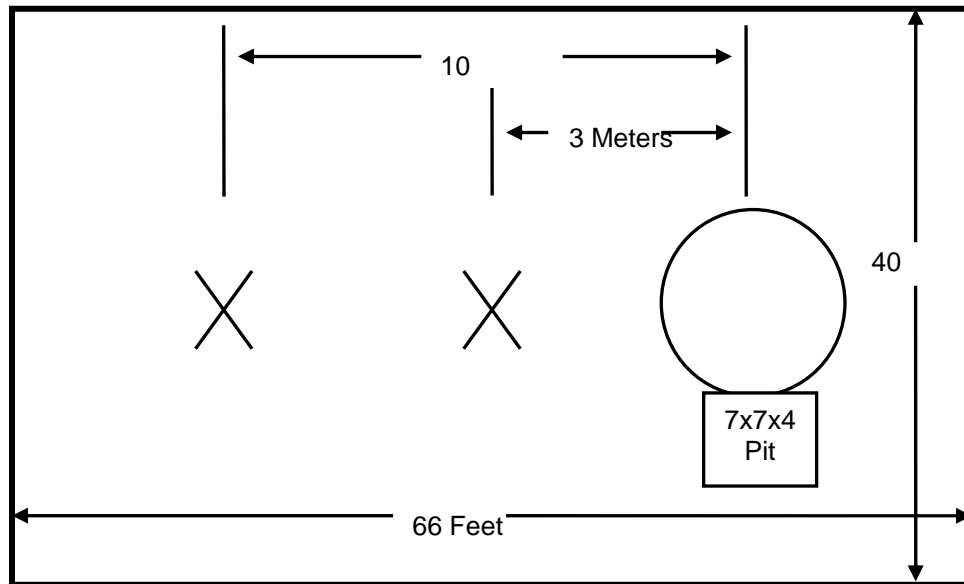

**Figure 2.3-2: Open Area Test Site**

### 3.0 APPLICABLE STANDARD REFERENCES

The following standards were used:

- 1 - ANSI C63.4-2003: Method of Measurements of Radio-Noise Emissions from Low-Voltage Electrical and Electronic Equipment in the 9KHz to 40GHz - 2003
- 2 - US Code of Federal Regulations (CFR): Title 47, Part 2, Subpart J: Equipment Authorization Procedures - 2010
- 3 - US Code of Federal Regulations (CFR): Title 47, Part 24, Subpart D: Personal Communication Service - 2010
- 4 - US Code of Federal Regulations (CFR): Title 47, Part 90, Subpart I: Private Land Mobile Radio Services - 2010
- 5 - US Code of Federal Regulations (CFR): Title 47, Part 101, Subpart C: Fixed Microwave Services – 2010
- 6 - TIA-603-C: Land Mobile FM or PM - Communications Equipment - Measurement and Performance Standards – 2004
- 7 - Industry Canada Radio Standards Specification: RSS-119 - Land Mobile and Fixed Radio Transmitters and Receivers Operating in the Frequency Range 27.41-960 MHz - Issue 10, April 2010
- 8 - Industry Canada Radio Standards Specification: RSS-134 - 900 MHz Narrowband Personal Communications Services - Issue 1, Revision 1, March 25, 2000

### 4.0 LIST OF TEST EQUIPMENT

The calibration interval of test equipment is annually or the manufacturer's recommendations. Where the calibration interval deviates from the annual cycle based on the instrument manufacturer's recommendations, it shall be stated below.

**Table 4-1: Test Equipment**

AssetID	Manufacturer	Model #	Equipment Type	Serial #	Last Calibration Date	Calibration Due Date
283	Rohde & Schwarz	FSP40	Spectrum Analyzers	1000033	8/31/2010	8/31/2011
340	Aeroflex/Weinschel	AS-20	Attenuators	7136	10/5/2010	10/5/2011
302	TryGon Electronics	DL40-1	General Lab Equipment	489512	NCR	NCR



5.0 SUPPORT EQUIPMENT

Table 5-1: Support Equipment

Diagram #	Manufacturer	Equipment Type	Model Number	Serial Number
1	Trygon Electronics	DC Power Supply	DL40-1	489512

6.0 EQUIPMENT UNDER TEST SETUP AND BLOCK DIAGRAM

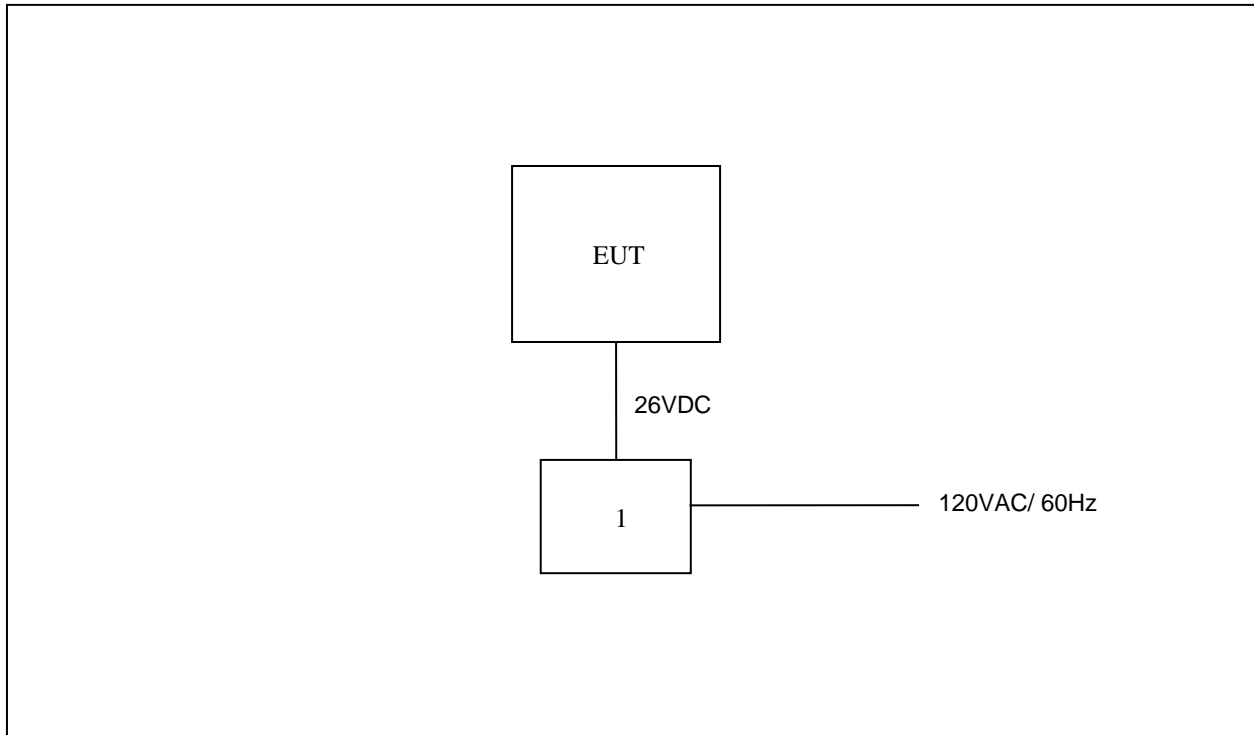

Figure 6-1: EUT Test Setup

**7.0 SUMMARY OF TESTS**

Along with the tabular data shown below, plots were taken of all signals deemed important enough to document.

**7.1 Occupied Bandwidth (Emission Limits)**

**7.1.1 Measurement Procedure**

The RF output of the equipment under test was directly connected to the input of the Spectrum Analyzer through a 20 dB passive attenuator. The spectrum analyzer resolution and video bandwidths were set to 300 Hz and 1 kHz respectively. The internal correction factors of the spectrum analyzer were employed to correct for any cable or attenuator losses. Results of the test are shown below for all modes of operation.

**7.1.2 Measurement Results**

**Part 24.133 a(1), a(2), IC RSS-134 6.3(i), (ii)**

The mPass (10kbps) modulation format/mode does not comply with Part 24.133(a)(2) for transmitters authorized a bandwidth of 10kHz. The mPass (10kbps) modulation format/mode only complies with Part 24.133(a)(1) for transmitters authorized a bandwidth greater than 10kHz.

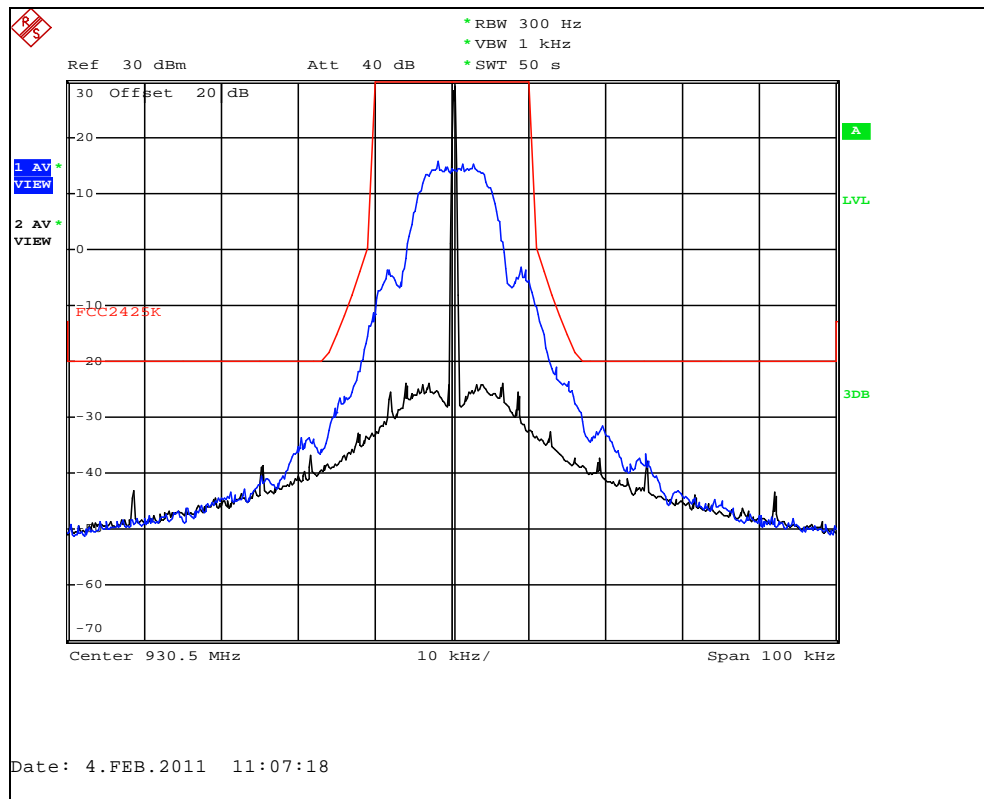

**Figure 7.2.2-1: mPass (10kbps) Mode – 930.5 MHz – 25 kHz Channel**

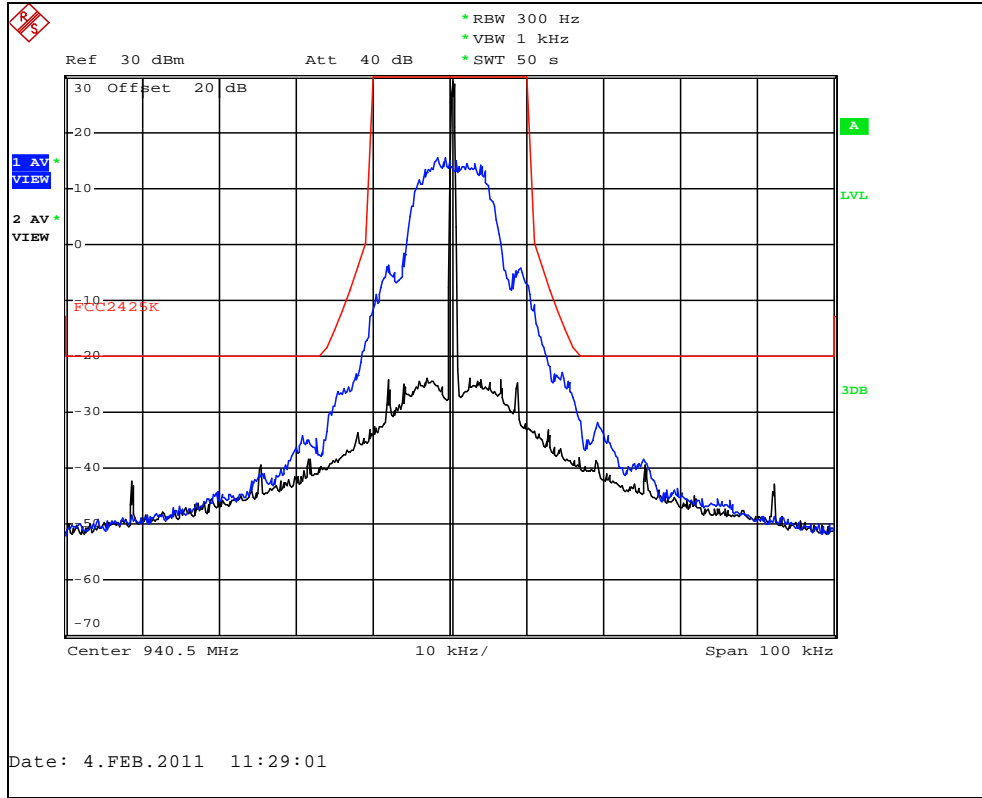
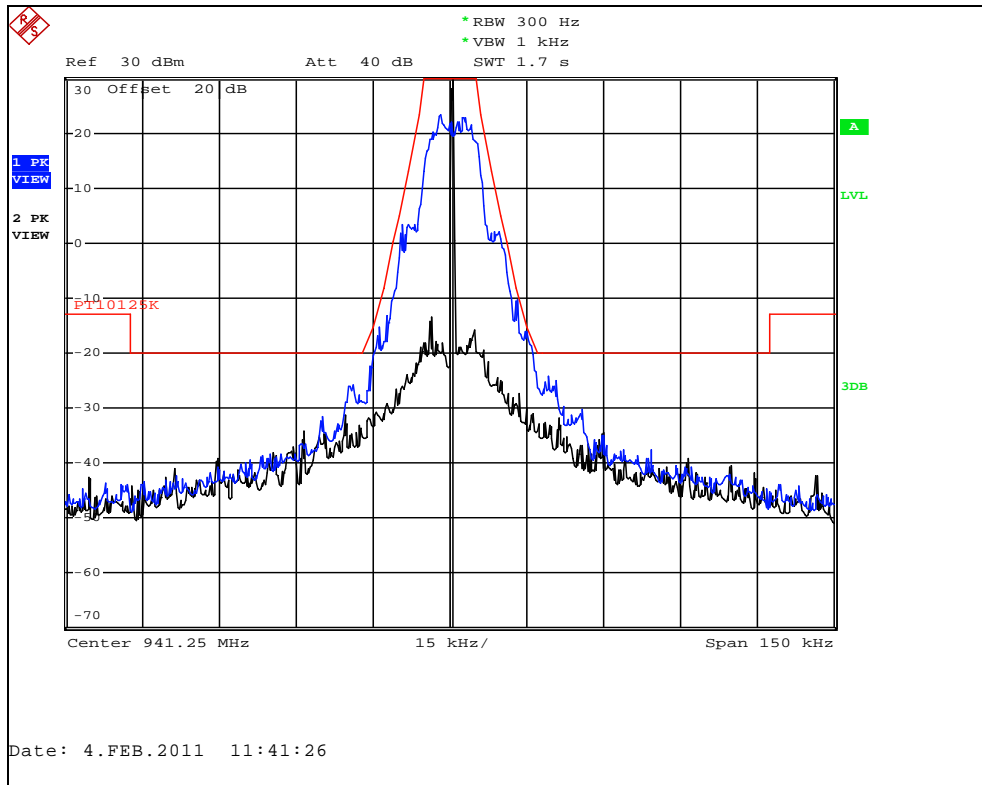

Figure 7.2.2-2: mPass (10kbps) Mode – 940.5 MHz – 25 kHz Channel

**Part 101.111 a(6), RSS-119 5.8.6\***

\* FCC Part 101.111a(6) provides worst case



**Figure 7.2.2-3: mPass (10kbps) Mode – 941.25 MHz**

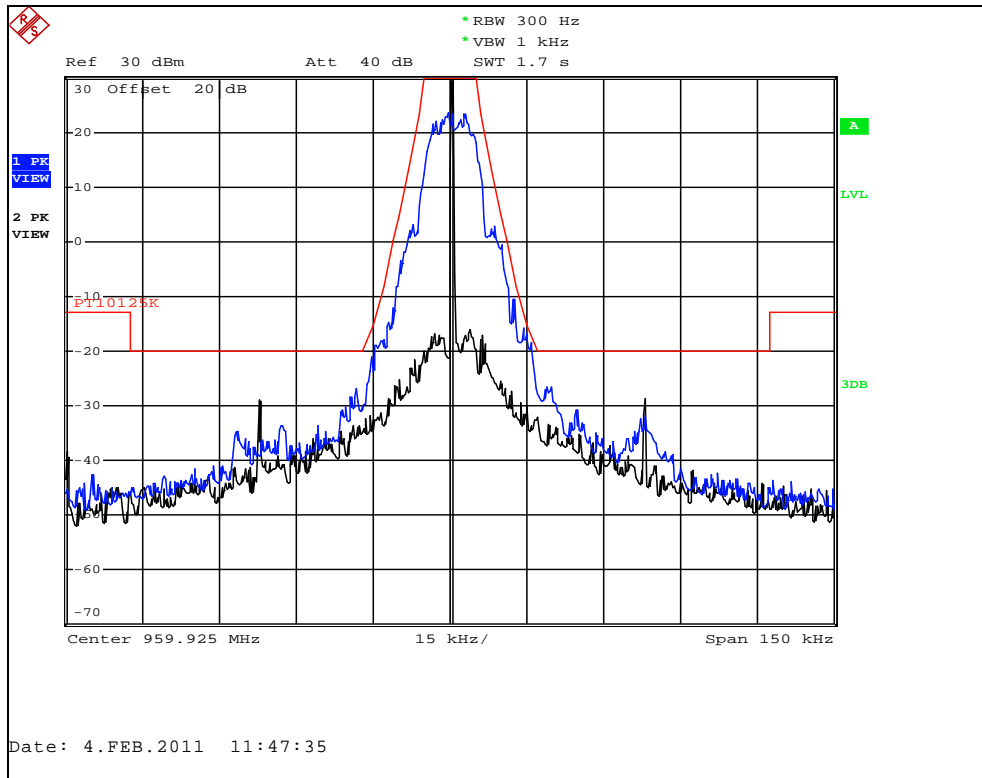

**Figure 7.2.2-4: mPass (10kbps) Mode – 959.925 MHz**

## 8.0 CONCLUSION

In the opinion of ACS, Inc. model IDTB001 meets all the requirements of FCC Part 24, 90, and 101 as well as IC RSS-119 and RSS-134 as applicable.

End Report