

Certification Test Report

**FCC ID: SDBFLEXLG100
IC: 2220A-FLEXLG100**

**FCC Rule Part: CFR 47 Part 24 Subpart D, Part 90 Subpart I, Part 101
Subpart C**

IC Radio Standards Specification: RSS 119, RSS 134

ACS Report Number: 08-0432-LD

**Applicant: Sensus Metering Systems
Model: FLEXLG100**

**Test Begin Date: November 19, 2008
Test End Date: December 23, 2008**

Report Issue Date: May 4, 2009



FOR THE SCOPE OF ACCREDITATION UNDER LAB Code 200612-0

This report is not to be used to claim certification, approval, or endorsement by NVLAP, NIST or any government agency.

Prepared by: Ken Rivers
Ken Rivers
Wireless Certifications Technician
ACS, Inc.

Reviewed by: J. Kirby Munroe
J. Kirby Munroe
Manager Wireless Certifications
ACS, Inc.

This test report shall not be reproduced except in full. This report may be reproduced in part with prior written consent of ACS, Inc. The results contained in this report are representative of the sample(s) submitted for evaluation.

This report contains 47 pages

Table of Content

1.0 General	3
1.1 Purpose	3
1.2 Product Description	3
1.3 Test Methodology	3
1.3.2 In-Band Testing Methodology	3
1.4 Emission Designators	4
2.0 Test Facilities	5
2.1 Location	5
2.2 Laboratory Accreditations/Recognitions/Certifications	5
2.3 Radiated Emissions Test Site Description	6
2.3.1 Semi-Anechoic Chamber Test Site	6
2.3.2 Open Area Tests Site (OATS)	7
2.4 Conducted Emissions Test Site Description	8
3.0 Applicable Standards and References	8
4.0 List of Test Equipment	9
5.0 Support Equipment	10
6.0 EUT Setup and Block Diagram	10
7.0 Summary of Tests	11
7.1 RF Power Output	11
7.1.1 Measurement Procedure	11
7.1.2 Measurement Results	11
7.2 Occupied Bandwidth (Emission Limits)	16
7.2.1 Measurement Procedure	16
7.2.2 Measurement Results	16
7.3 Spurious Emissions at Antenna Terminals	26
7.3.1 Measurement Procedure	26
7.3.2 Measurement Results	26
7.4 Field Strength of Spurious Emissions	34
7.4.1 Measurement Procedure	34
7.4.2 Measurement Results	34
7.5 Frequency Stability	38
7.5.1 Measurement Procedure	38
7.5.2 Measurement Results	39
7.6 Radiated Emissions (Unintentional Radiators)	47
7.6.1 Measurement Procedure	47
7.6.2 Measurement Results	47
8.0 Conclusion	47

Additional Exhibits Included In Filing

Internal Photographs	External Photographs
Tune-up Procedure	Test Setup Photographs
Product Labeling	RF Exposure – MPE Calculations
Installation/Users Guide	System Block Diagram
Theory of Operation	Parts List
Schematics	

1.0 GENERAL

1.1 Purpose

The purpose of this report is to demonstrate compliance with Part 2 Subpart J, Part 24 Subpart D, Part 90 Subpart I, and Part 101 Subpart C of the FCC's Code of Federal Regulations; and RSS 119 and 134 of Industry Canada's Radio Standard Specifications.

1.2 Product Description

The Flexnet Focus Transceiver model FLEXLG100 is a modular printed circuit board that provides wireless communication capability between an electric meter and a back-end system. The device will communicate via the fixed wireless telemetry network to provide electric meter readings and diagnostic data from the meter to the utility provider.

Manufacturer Information:
Sensus Metering Systems, Inc.
44 Castillian Drive
Goleta, CA 93117
(805) 562-5390

Test Sample Serial Numbers: 004775 (RF conducted), 004724 (radiated)

Test Sample Condition: The test samples were provided in good working order with no visible defects.

Detailed photographs of the EUT are filed separately with this filing.

1.3 Test Methodology

1.3.1 Test Configurations and Justification

For RF conducted measurements, the FLEXLG100 was modified with an external RF connector to the PCB. The FLEXLG100 utilizes non-detachable antennas for normal operation but for RF conducted testing the antennas were disconnected and a 50-Ohm test cable soldered (with the appropriate ground connection) to the PCB.

1.3.2 In-Band Testing Methodology

For testing in accordance with 47 CFR 2.1046-2.1057, OET/Lab recommends that the following be used to select test frequencies for licensed devices:

Frequency range over which device operates	Number of frequencies	Location in the range of operation
1 MHz or less	1	Middle
1 to 10 MHz	2	1 near top and 1 near bottom
10 to 100 MHz	3	1 near top, 1 near middle and 1 near bottom

The FLEXLG100 module is designed to operate in multiple bands under the requirements of CFR 47 Parts 24, 90, and 101. The following is a list of the frequency bands of operation sorted based on the FCC rule parts in which the band is associated.

CFR Title 47 Rule Part	Frequency Band of Operation (MHz)
24D	901.0 - 902.0
24D	930.0 - 931.0
24D	940.0 - 941.0
90	896.0125 - 901.0
90	935.0 - 940.0
101	928.85 - 929.0
101	932.0 - 932.5
101	941.0 - 941.5
101	959.85 - 960.0

Based on the requirements set forth in accordance 47 CFR 2.1046-2.1057 as stated above, the methodology in selecting the places to test in the available bands of operation is outlined in the following table.

CFR Title 47 Rule Part	Frequency Band of Operation (MHz)	Location in the Range of Operation
90	896.0125 - 901.0	1 near top and 1 near bottom
24D	901.0 - 902.0	
101	928.85 - 929.0	Middle
24D	930.0 - 931.0	Middle
101	932.0 - 932.5	Middle
90	935.0 - 940.0	1 near top and 1 near bottom
24D	940.0 - 941.0	
101	941.0 - 941.5	
101	959.85 - 960.0	Middle

The data provided in this report is sorted based on the rule part.

1.4 Emission Designators

The FLEXLG100 transmitter produces four distinct modulation formats. The emissions designators for the four modulation types used by the FLEXLG100 Transmitter are as follows:

EMISSIONS DESIGNATORS:

- Normal Mode: 9K60F2D
- Half-Baudrate Mode: 4K80F2D
- Boost Mode: 1K10F2D
- MPass Mode: 5K90F1D

2.0 TEST FACILITIES

2.1 Location

The radiated and conducted emissions test sites are located at the following address:

Advanced Compliance Solutions
5015 B.U. Bowman Drive
Buford, GA 30518
Phone: (770) 831-8048
Fax: (770) 831-8598

2.2 Laboratory Accreditations/Recognitions/Certifications

The Semi-Anechoic Chamber Test Site, Open Area Test Site (OATS) and Conducted Emissions Site have been fully described, submitted to, and accepted by the FCC, Industry Canada and the Japanese Voluntary Control Council for Interference by information technology equipment. In addition, ACS is compliant to ISO 17025 as certified by the National Institute of Standards and Technology under their National Voluntary Laboratory Accreditation Program. The following certification numbers have been issued in recognition of these accreditations and certifications:

FCC Registration Number: 894540
Industry Canada Lab Code: IC 4175
VCCI Member Number: 1831

- VCCI OATS Registration Number R-1526
- VCCI Conducted Emissions Site Registration Number: C-1608

NVLAP Lab Code: 200612-0

2.3 Radiated Emissions Test Site Description

2.3.1 Semi-Anechoic Chamber Test Site

The Semi-Anechoic Chamber Test Site consists of a 20' x 30' x 18' shielded enclosure. The chamber is lined with Toyo Ferrite Grid Absorber, model number FFG-1000. The ferrite tile grid is 101 x 101 x 19mm thick and weighs approximately 550 grams. These tiles are mounted on steel panels and installed directly on the inner walls of the chamber.

The turntable is 150cm in diameter and is located 160cm from the back wall of the chamber. The chamber is grounded via 1 - 8' copper ground rod, installed at the center of the back wall, it is bound to the ground plane using 3/4" stainless steel braided cable.

The turntable is all steel, flush mounted table installed in an all steel frame. The table is remotely operated from inside the control room located 25' from the range. The turntable is electrically bonded to the surrounding ground plane via steel fingers installed on the edge of the turn table. The steel fingers make constant contact with the ground plane during operation.

Behind the turntable is a 3' x 6' x 4' deep shielded pit used for support equipment if necessary. The pit is equipped with 1 - 4" PVC chases from the turntable to the pit that allow for cabling to the EUT if necessary. The underside of the turntable can be accessed from the pit so cables can be supplied to the EUT from the pit.

A diagram of the Semi-Anechoic Chamber Test Site is shown in Figure 2.3-1 below:

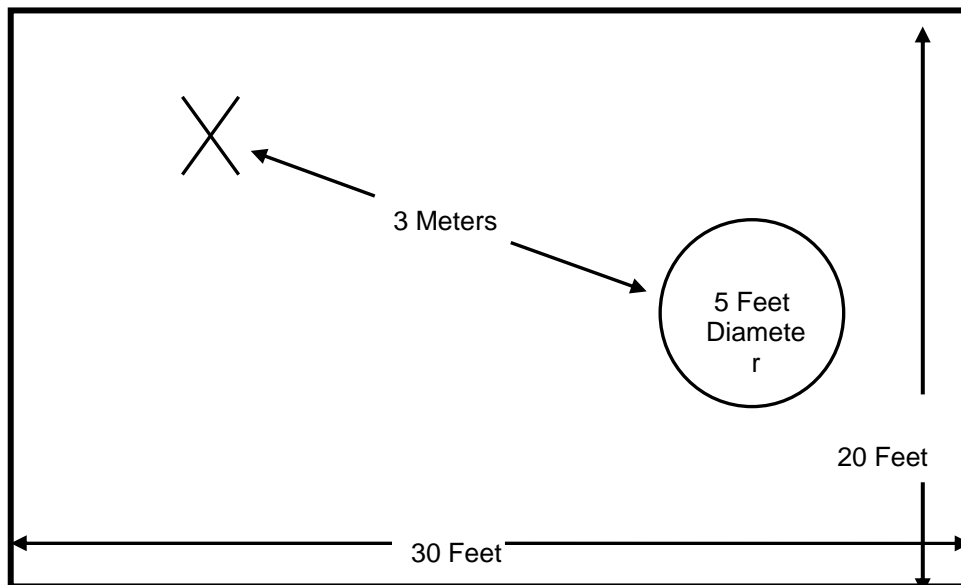

Figure 2.3-1: Semi-Anechoic Chamber Test Site

2.3.2 Open Area Tests Site (OATS)

The open area test site consists of a 40' x 66' concrete pad covered with a perforated electro-plated galvanized sheet metal. The perforations in the sheet metal are 1/8" holes that are staggered every 3/16". The individual sheets are placed to overlap each other by 1/4" and are riveted together to provide a continuous seam. Rivets are spaced every 3" in a 3 x 20 meter perimeter around the antenna mast and EUT area. Rivets in the remaining area are spaced as necessary to properly secure the ground plane and maintain the electrical continuity.

The entire ground plane extends 12' beyond the turntable edge and 16' beyond the antenna mast when set to a 10 meter measurement distance. The ground plane is grounded via 4 - 8' copper ground rods, each installed at a corner of the ground plane and bound to the ground plane using 3/4" stainless steel braided cable.

The turntable is an all aluminum 10' flush mounted table installed in an all aluminum frame. The table is remotely operated from inside the control room located 40' from the range. The turntable is electrically bonded to the surrounding ground plane via steel fingers installed on the edge of the turn table. The steel fingers make constant contact with the ground plane during operation.

Adjacent to the turntable is a 7' x 7' square and 4' deep concrete pit used for support equipment if necessary. The pit is equipped with 5 - 4" PVC chases from the pit to the control room that allow for cabling to the EUT if necessary. The underside of the turntable can be accessed from the pit so cables can be supplied to the EUT from the pit. The pit is covered with 2 sheets of 1/4" diamond style re-enforced steel sheets. The sheets are painted to match the perforated steel ground plane; however the underside edges have been masked off to maintain the electrical continuity of the ground plane. All reflecting objects are located outside of the ellipse defined in ANSI C63.4.

A diagram of the Open Area Test Site is shown in Figure 2.3-2 below:

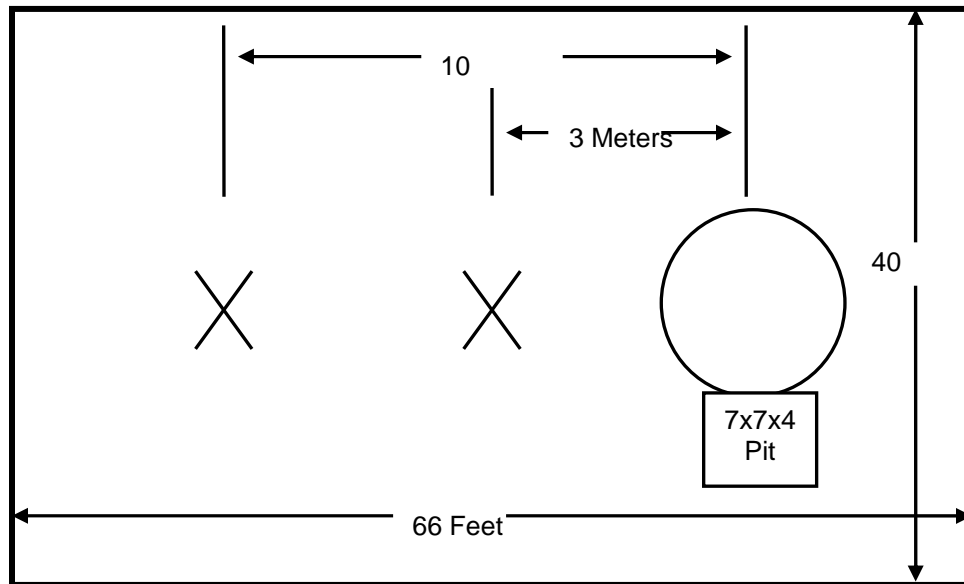

Figure 2.3-2: Open Area Test Site

2.4 Conducted Emissions Test Site Description

The AC mains conducted EMI site is located in the main EMC lab. It consists of an 8' x 8' solid aluminum horizontal group reference plane (GRP) bonded every 3" to an 8' X 8' vertical ground plane.

The site is of sufficient size to test table top and floor standing equipment in accordance with section 6.1.4 of ANSI C63.4.

A diagram of the room is shown below in figure 4.1.3-1:

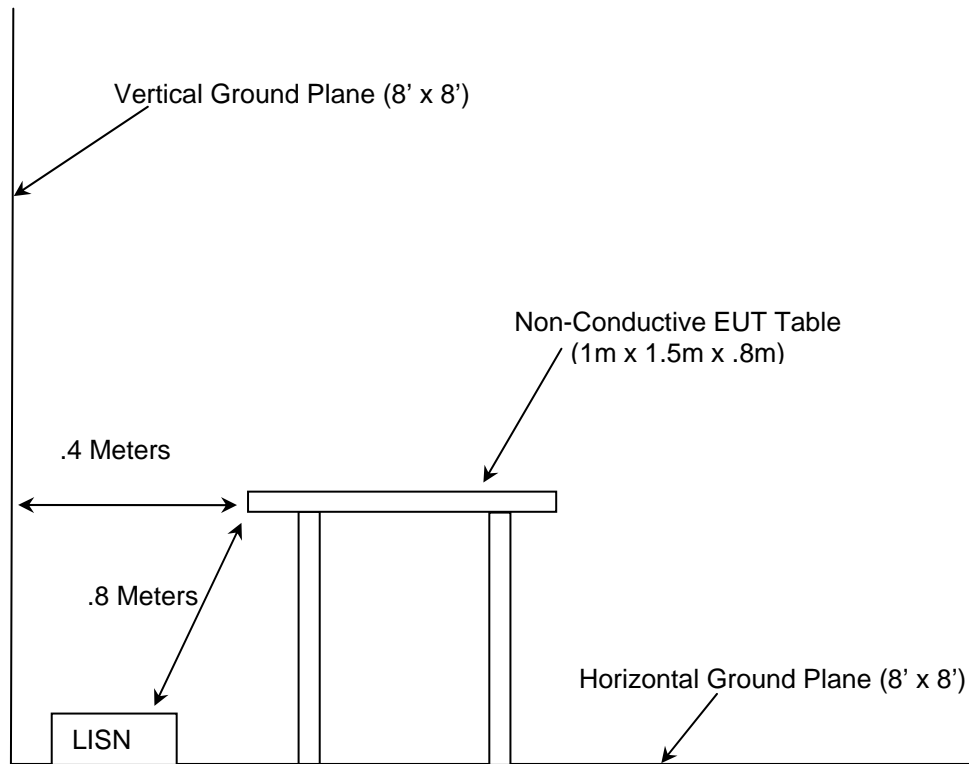

Figure 2.4-1: AC Mains Conducted EMI Site

3.0 APPLICABLE STANDARD REFERENCES

The following standards were used:

- 1 - ANSI C63.4-2003: Method of Measurements of Radio-Noise Emissions from Low-Voltage Electrical and Electronic Equipment in the 9KHz to 40GHz - 2003
- 2 - US Code of Federal Regulations (CFR): Title 47, Part 2, Subpart J: Equipment Authorization Procedures - 2008
- 3 - US Code of Federal Regulations (CFR): Title 47, Part 24, Subpart D: Personal Communication Service - 2008
- 4 - US Code of Federal Regulations (CFR): Title 47, Part 90, Subpart I: Private Land Mobile Radio Services - 2008
- 5 - US Code of Federal Regulations (CFR): Title 47, Part 101, Subpart C: Fixed Microwave Services – 2008
- 6 – TIA-603-C: Land Mobile FM or PM - Communications Equipment - Measurement and Performance Standards – 2004
- 7 - Industry Canada Radio Standards Specification: RSS-119 - Land Mobile and Fixed Radio Transmitters and Receivers Operating in the Frequency Range 27.41-960 MHz - Issue 9, June 2007
- 8 - Industry Canada Radio Standards Specification: RSS-134 - 900 MHz Narrowband Personal Communications Services - Issue 1, Revision 1, March 25, 2000

4.0 LIST OF TEST EQUIPMENT

The calibration interval of test equipment is annually or the manufacturer's recommendations. Where the calibration interval deviates from the annual cycle based on the instrument manufacturer's recommendations, it shall be stated below.

Table 4-1: Test Equipment

Equipment Calibration Information					
ACS#	Mfg.	Eq. type	Model	S/N	Cal. Due
1	Rohde & Schwarz	Spectrum Analyzers	ESMI - Display	833771/007	09-19-2009
2	Rohde & Schwarz	Spectrum Analyzers	ESMI-Receiver	839587/003	09-19-2009
22	Agilent	Amplifiers	8449B	3008A00526	10-22-2009
25	Chase	Antennas	CBL6111	1043	08-22-2009
30	Spectrum Technologies	Antennas	DRH-0118	970102	05-07-2009
167	ACS	Cable Set	Chamber EMI Cable Set	167	01-04-2009 (See Note1)
222	Andrew	Cables	F1-SMSM	473703-A0138A	08-07-2009 (See Note1)
283	Rohde & Schwarz	Spectrum Analyzers	FSP40	1000033	09-19-2009
291	Florida RF Cables	Cables	SMRE-200W-12.0-SMRE	None	11-21-2008 (See Note1)
292	Florida RF Cables	Cables	SMR-290AW-480.0-SMR	None	11-21-2008 (See Note1)
321	Hewlett Packard	Amplifiers	HPC 8447D	1937A02809	10-08-2009
329	A.H.Systems	Antennas	SAS-571	721	
337	Microwave Circuits	Filters	H1G513G1	282706	04-08-2009 (See Note1)
338	Hewlett Packard	Amplifiers	8449B	3008A01111	10-22-2009
339	Aeroflex/Weinschel	Attenuators	AS-18	7142	07-08-2009 (See Note2)
422	Florida RF	Cables	SMS-200AW-72.0-SMR	805	02-25-2009 (See Note1)

Note1: Items characterized on an annual cycle. The date shown indicates the next characterization due date.

Note2: Items verified on an annual cycle. The date shown indicates the next verification due date.

5.0 SUPPORT EQUIPMENT

Table 5-1: Support Equipment

Diagram #	Manufacturer	Equipment Type	Model Number	Serial Number	FCC ID
1	Systron Donner	Dual Power Supply	DL40-1	489512	NA

6.0 EQUIPMENT UNDER TEST SETUP AND BLOCK DIAGRAM

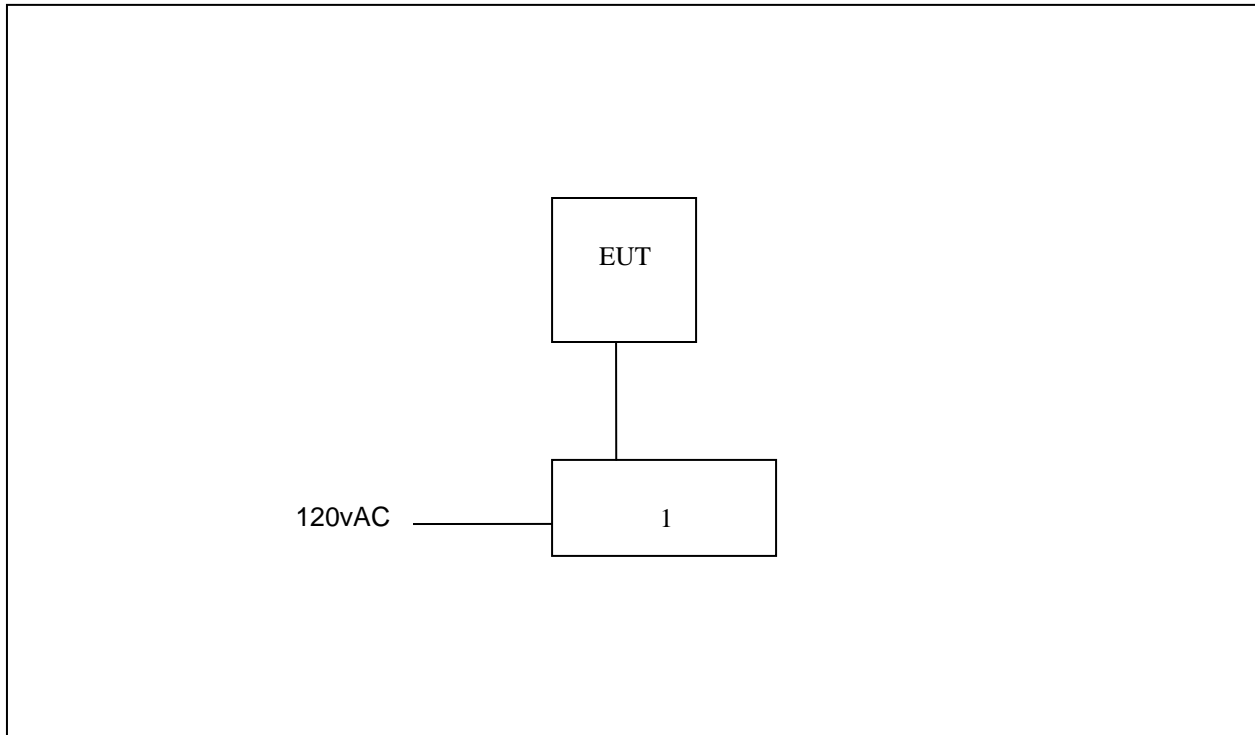

Figure 6-1: EUT Test Setup

* For RF conducted measurements, the FLEXLG100 transceiver was modified with an external 50-Ohm test cable soldered (with the appropriate ground connection) to the PCB.

7.0 SUMMARY OF TESTS

Along with the tabular data shown below, plots were taken of all signals deemed important enough to document.

7.1 RF Power Output

7.1.1 Measurement Procedure

The RF output of the equipment under test was directly connected to the input of the Spectrum Analyzer through a 20 dB passive attenuator. The resolution and video bandwidths of the spectrum analyzer were set at sufficient levels, >> signal bandwidth, to produce accurate results. The internal correction factors of the spectrum analyzer were employed to correct for any cable or attenuator losses. Results are shown below in Table 7.1.2-1 and Figure 7.1.2-1 through 7.1.2-8.

7.1.2 Measurement Results

Table 7.1.2-1: Peak Output Power

Frequency (MHz)	FCC Rule Part	Output Power (dBm)
901.9875	Part 24	29.39
930.5000	Part 24	29.17
896.0125	Part 90	29.52
935.0125	Part 90	29.15
928.9250	Part 101	29.19
932.2500	Part 101	29.11
941.4875	Part 101	29.02
959.9250	Part 101	28.94

Part 24.132/RSS-134 5.4(a)

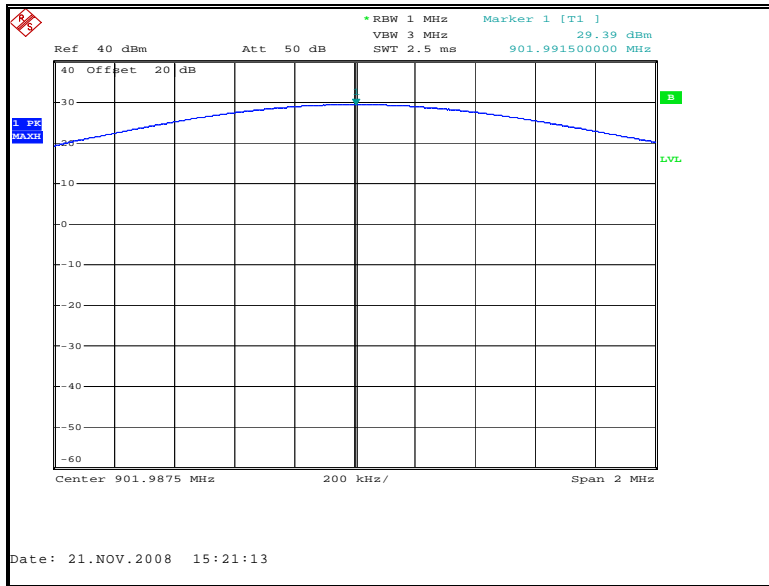

Figure 7.1.2-1: Peak Output Power 901.9875 MHz

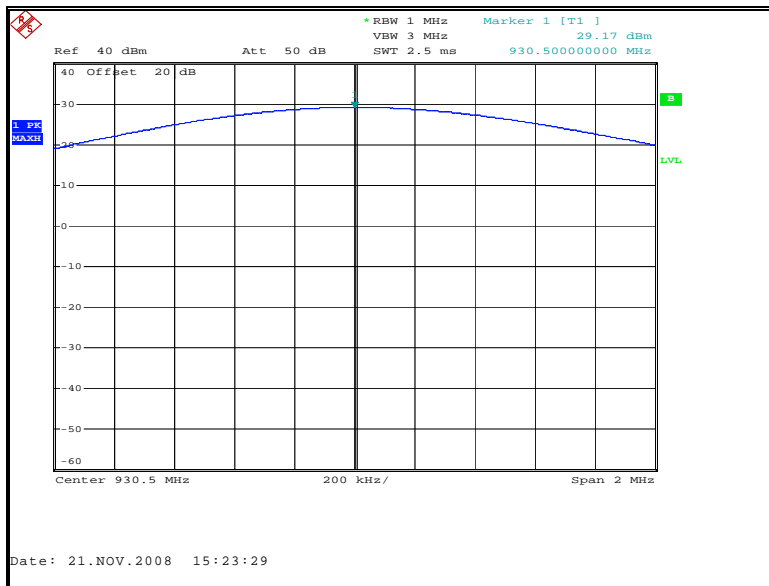

Figure 7.1.2-2: Peak Output Power 930.5 MHz

Part 90.635(d) / RSS-119 5.41



Figure 7.1.2-3: Peak Output Power 896.0125 MHz

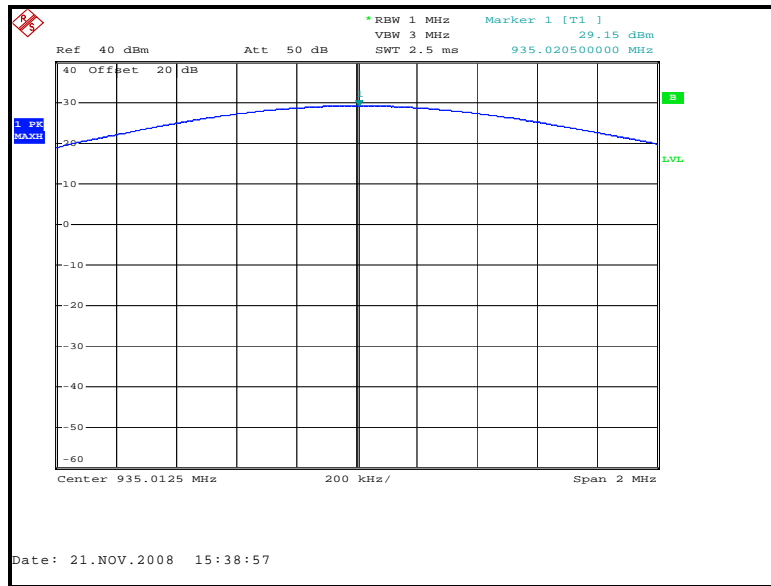

Figure 7.1.2-4: Peak Output Power 935.0125 MHz

Part 101.113(a) / RSS-119 5.41

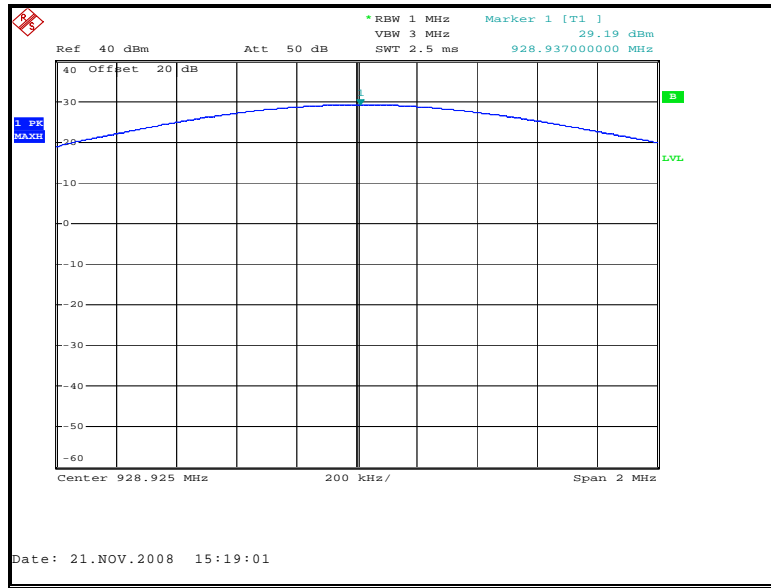

Figure 7.1.2-5: Peak Output Power 928.925 MHz

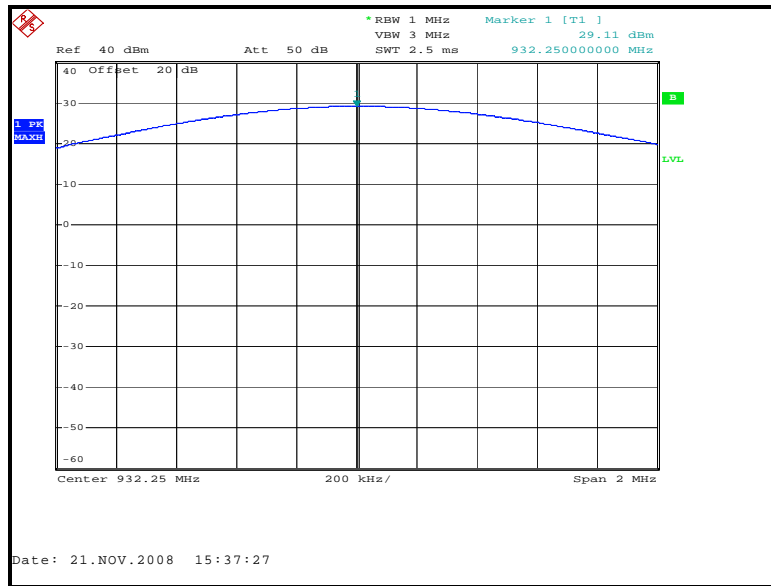

Figure 7.1.2-6: Peak Output Power 932.25 MHz



Figure 7.1.2-7: Peak Output Power 941.4875 MHz

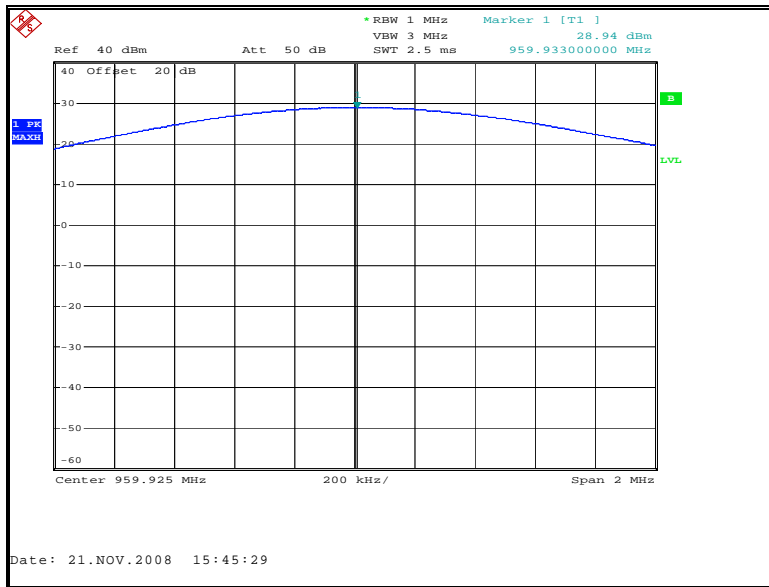

Figure 7.1.2-8: Peak Output Power 959.925 MHz

7.2 Occupied Bandwidth (Emission Limits) - FCC Section 2.1049

7.2.1 Measurement Procedure

The RF output of the equipment under test was directly connected to the input of the Spectrum Analyzer through a 20 dB passive attenuator. The spectrum analyzer resolution and video bandwidths were set to 300 Hz and 300 Hz respectively. The internal correction factors of the spectrum analyzer were employed to correct for any cable or attenuator losses. Results of the test are shown below for all modes of operation.

7.2.2 Measurement Results

Part 24.133 a(1), a(2), IC RSS-134 6.3(i), (ii)

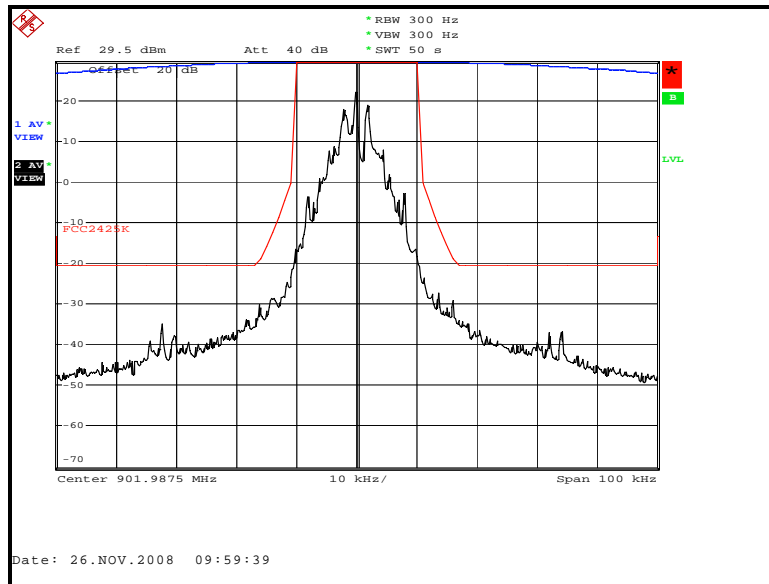

Figure 7.2.2-1: Normal Mode – 901.9875 MHz – 25 kHz Channel

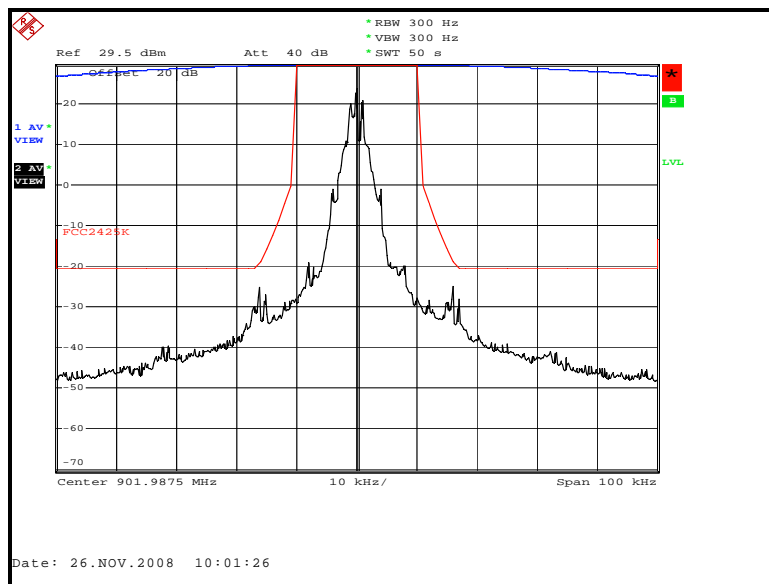

Figure 7.2.2-2: Half-Baud Rate Mode – 901.9875 MHz – 25 kHz Channel

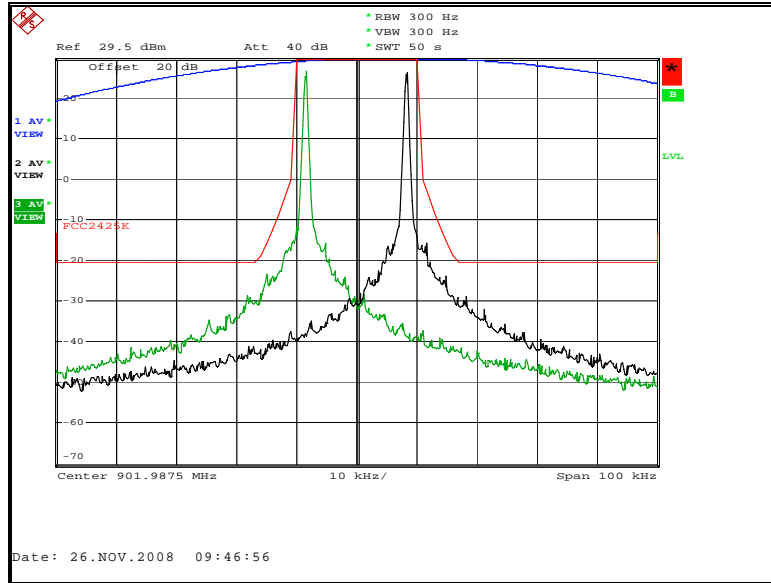

Figure 7.2.2-3: Boost Mode – 901.9875 MHz – 25 kHz Channel Offset Channel of +/- 14 (+/- 8400 Hz)

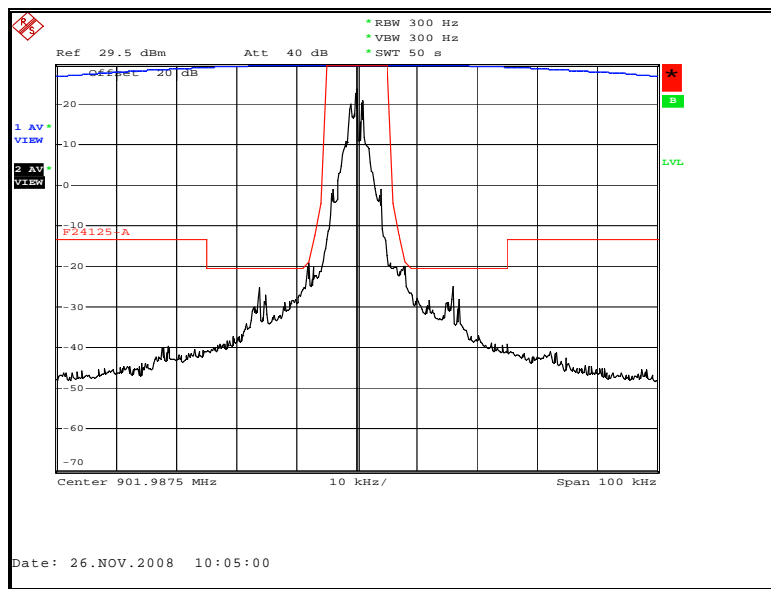

Figure 7.2.2-4: Half-Baud Rate – 901.9875 MHz – 12.5 kHz Channel

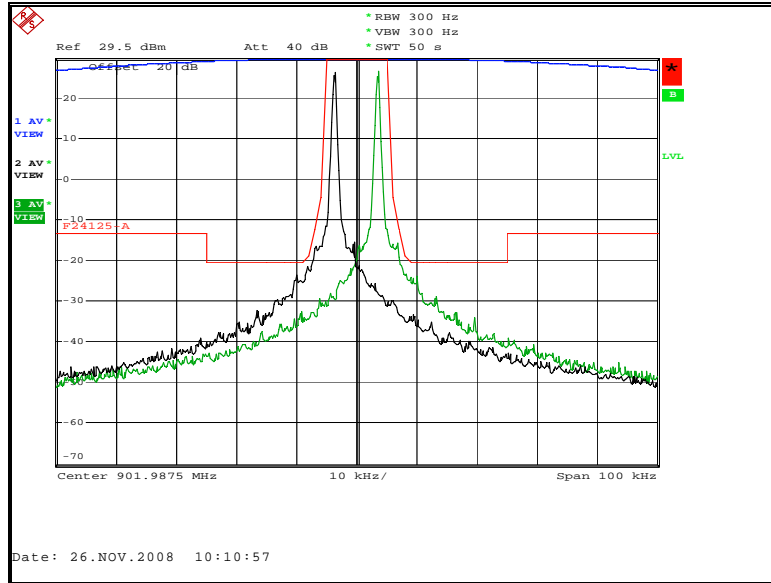

Figure 7.2.2-5: Boost Mode – 901.9875 MHz – 12.5 kHz Channel Offset Channel of +/- 6 (+/- 3600 Hz)

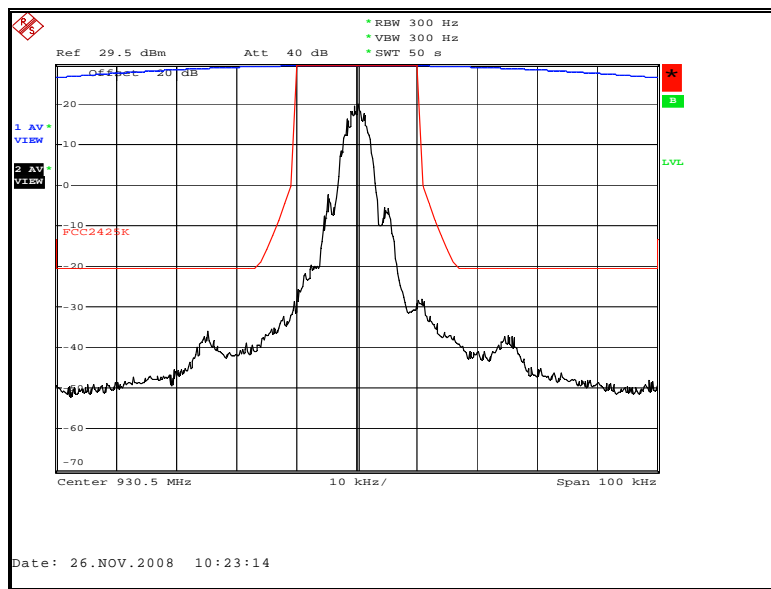

Figure 7.2.2-6: MPass Mode – 930.5 MHz – 25 kHz Channel

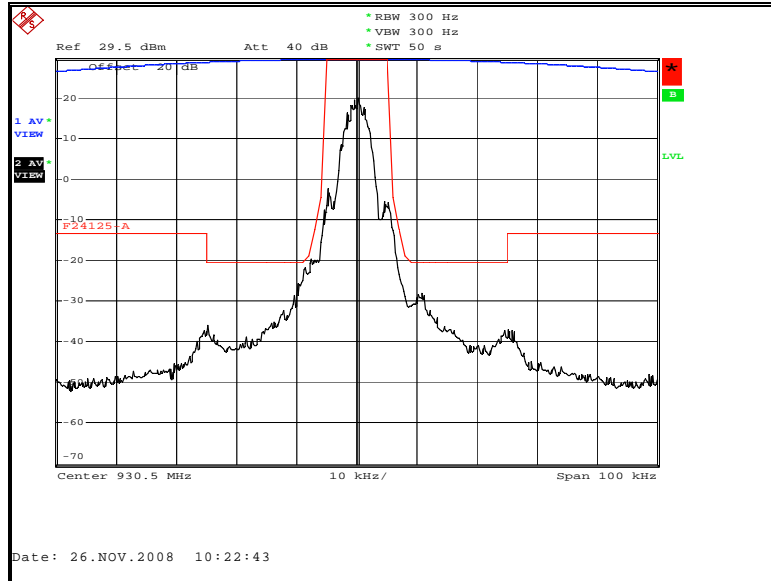

Figure 7.2.2-7: MPass Mode – 930.5 MHz – 12.5 kHz Channel

Part 90.210 (j), RSS-119 5.8.8

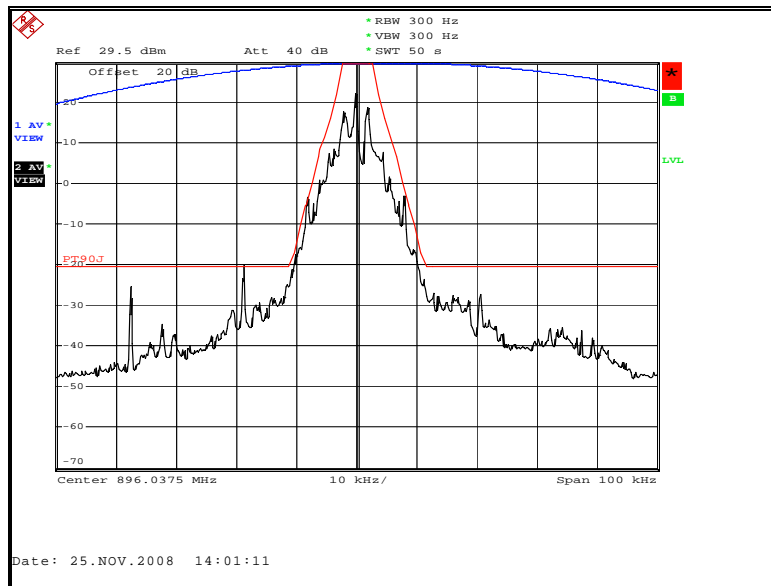

Figure 7.2.3-1: Normal Mode – 896.0375 MHz

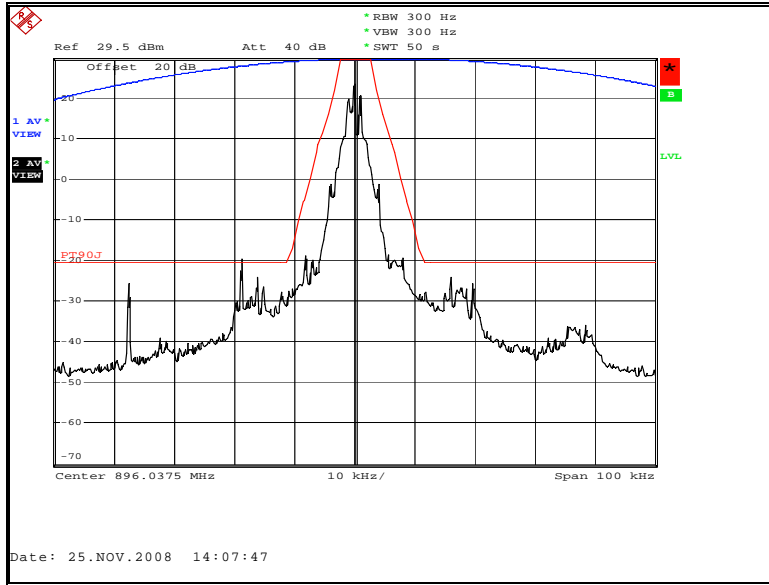

Figure 7.2.3-2: Half-Baud Rate Mode – 896.0375 MHz

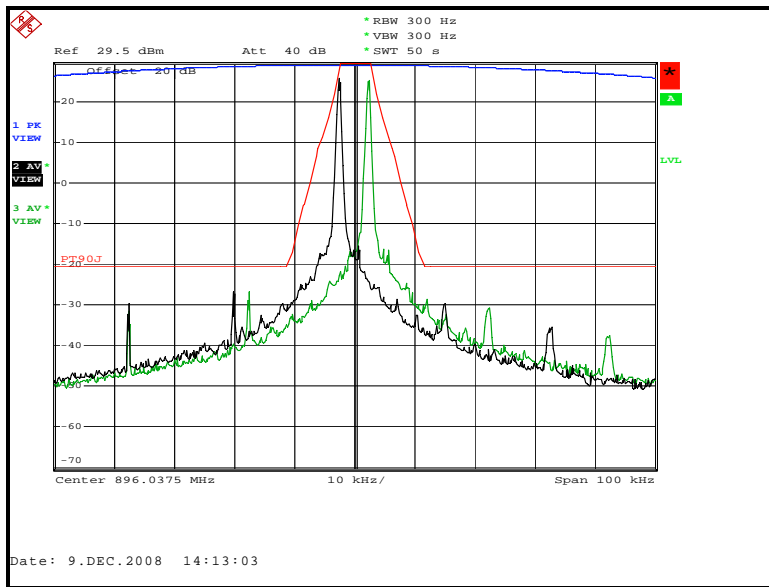

Figure 7.2.3-3: Boost Mode – 896.0375 MHz
Offset Channel of +/- 4 (+/- 2400 Hz)

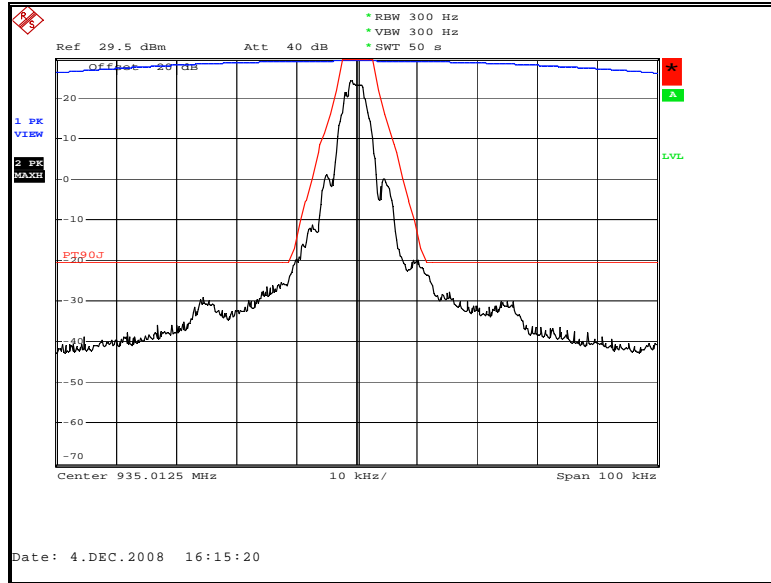

Figure 7.2.3-4: MPass Mode – 935.0125 MHz

Part 101.111 a(6), RSS-119 5.8.6*

* FCC Part 101.111a(6) provides worst case

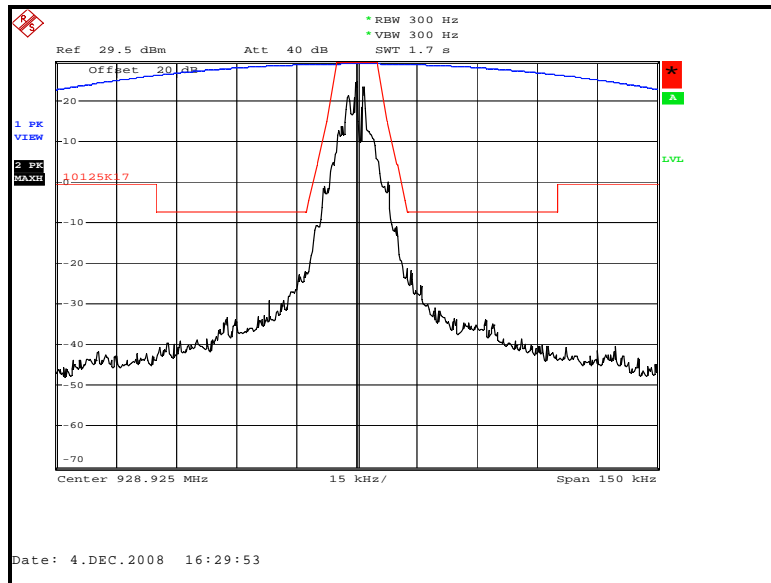

Figure 7.2.4-1: Normal Mode – 928.925 MHz

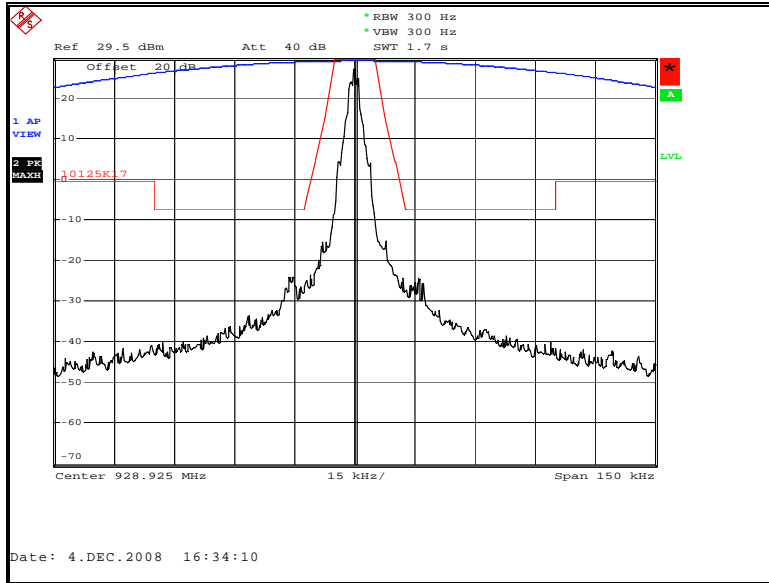

Figure 7.2.4-2: Half-Baud Rate Mode – 928.925 MHz

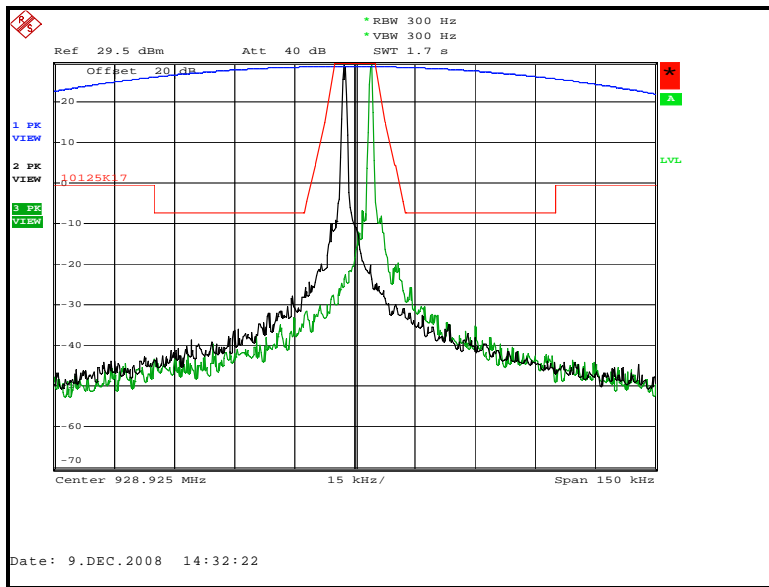

Figure 7.2.4-3: Boost Mode – 928.925 MHz
Offset Channel of +/- 7 (+/- 4200 Hz)

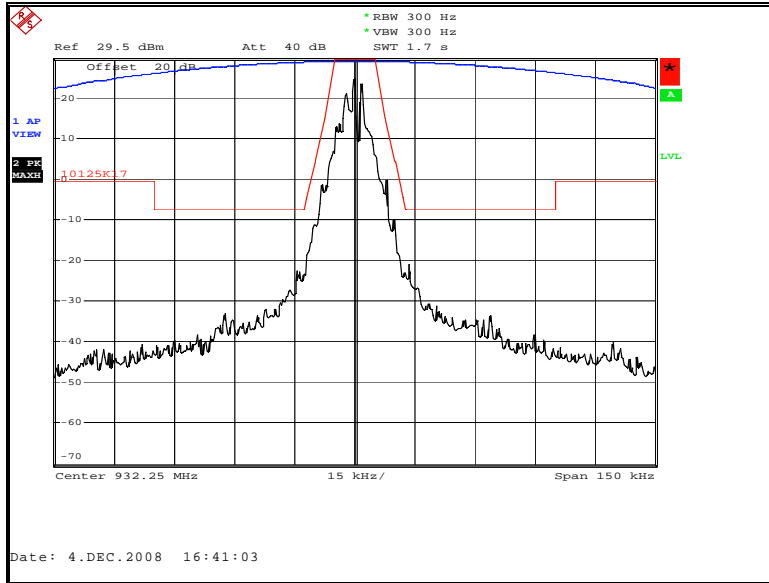

Figure 7.2.4-4: Normal Mode – 932.25 MHz

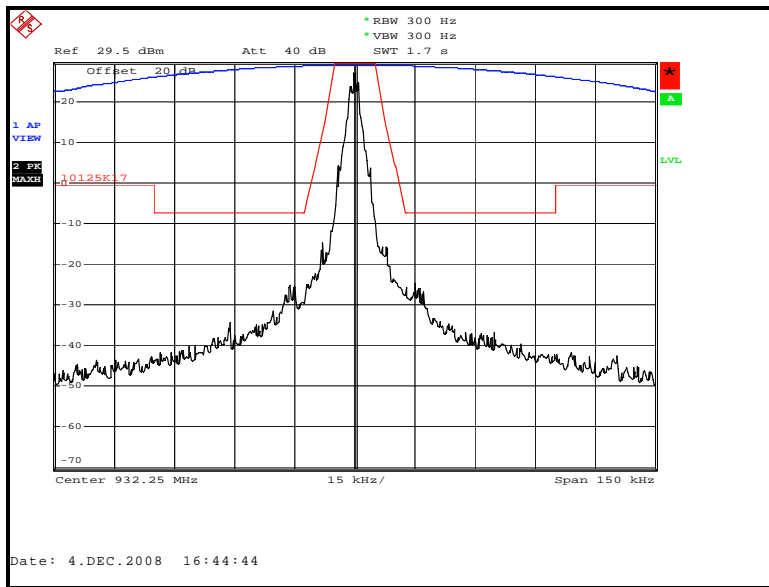

Figure 7.2.4-5: Half-Baud Rate Mode – 932.25 MHz

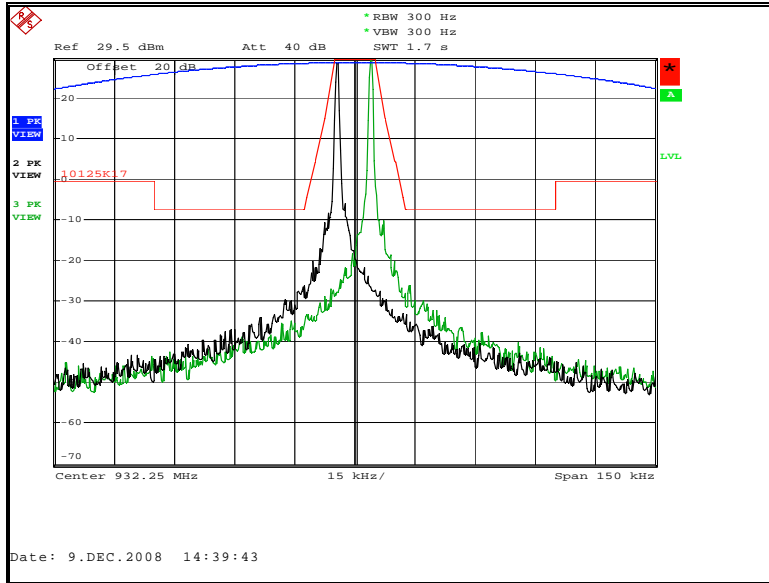

Figure 7.2.4-6: Boost Mode – 932.25 MHz
Offset Channel of +/- 7 (+/- 4200 Hz)

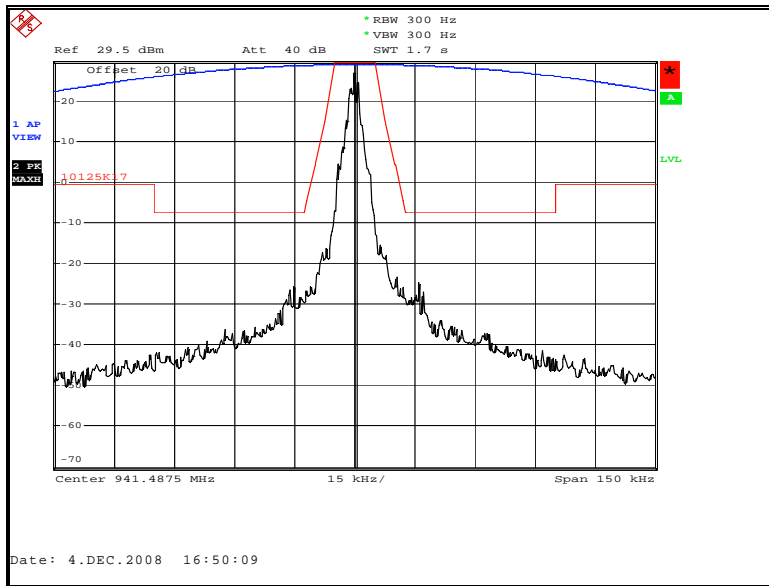

Figure 7.2.4-7: MPass Mode – 941.4875 MHz

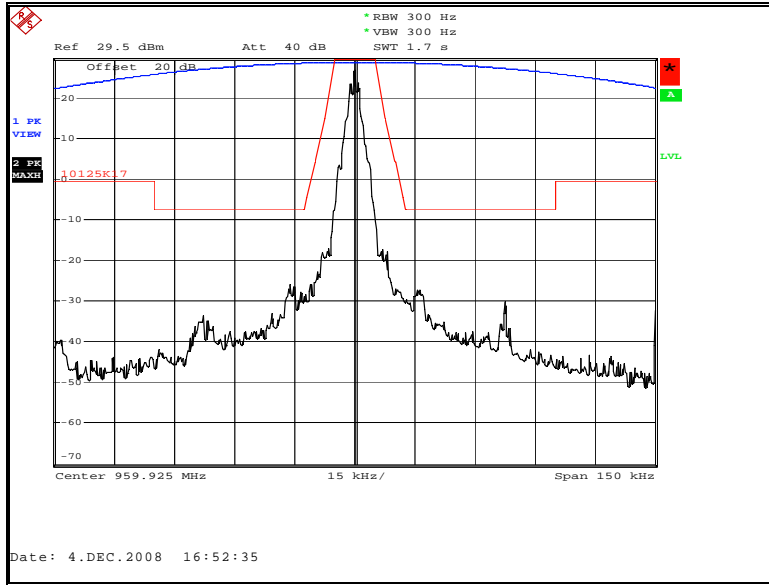

Figure 7.2.4-8: MPass Mode – 959.925 MHz

7.3 Spurious Emissions at Antenna Terminals

7.3.1 Measurement Procedure

The RF output of the equipment under test was directly connected to the input of the Spectrum Analyzer through a 20 dB passive attenuator. The spectrum analyzer resolution bandwidth was set to 30 kHz below 1000 MHz and 1 MHz above 1000 MHz. The internal correction factors of the spectrum analyzer were employed to correct for any cable or attenuator losses. The spectrum was investigated in accordance to CFR 47 Part 2.1057.

7.3.2 Measurement Results

Part 24.133 a(1), a(2), IC RSS-134 6.3(i), (ii)

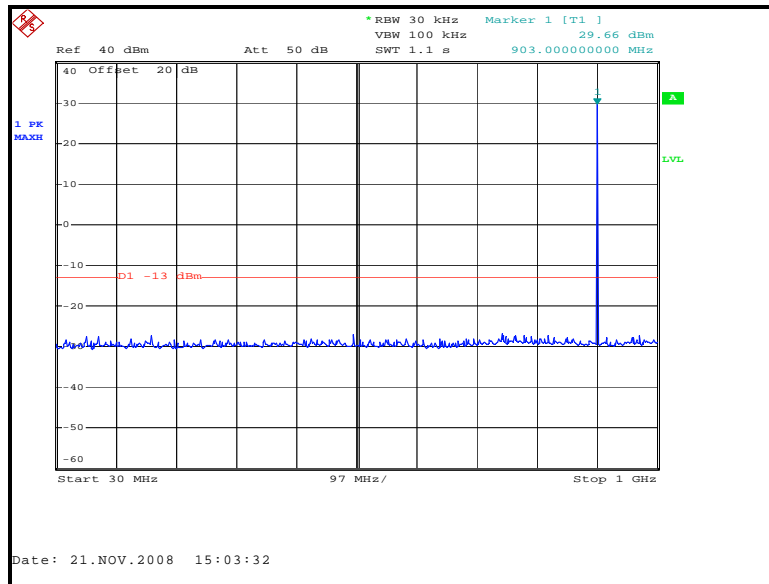

Figure 7.3.2-1: Normal Mode – 901.9875 MHz – 30MHz to 1GHz

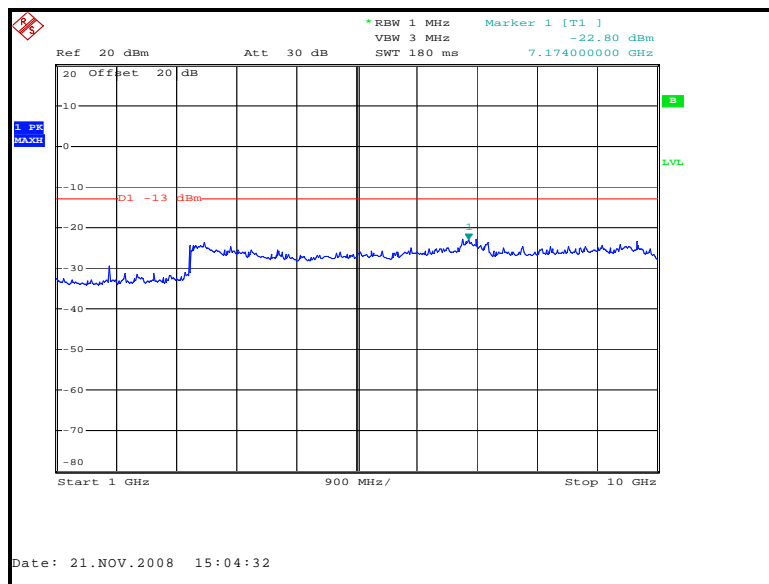

Figure 7.3.2-2: Normal Mode – 901.9875 MHz – 1GHz to 10GHz

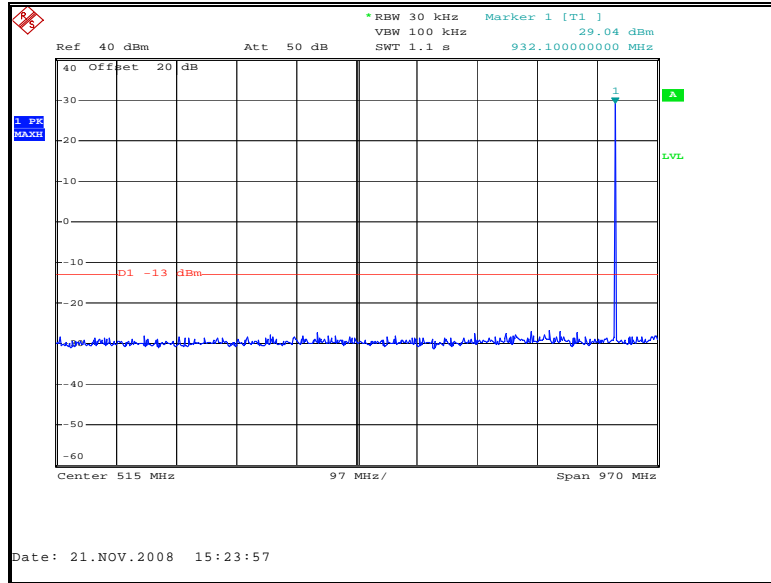

Figure 7.3.2-3: Mpass Mode – 930.5 MHz – 30MHz to 1GHz

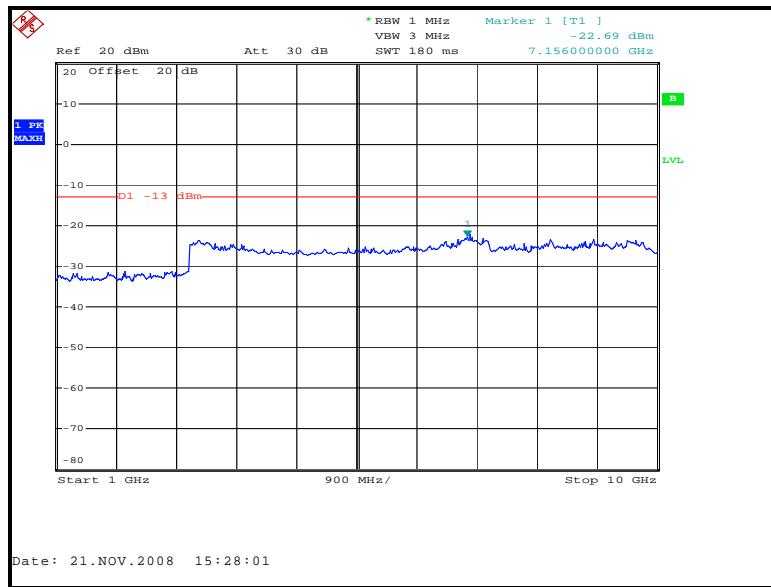

Figure 7.3.2-4: Mpass Mode – 930.5 MHz – 1GHz to 10GHz

Part 90.210 (j), RSS-119 5.8.8

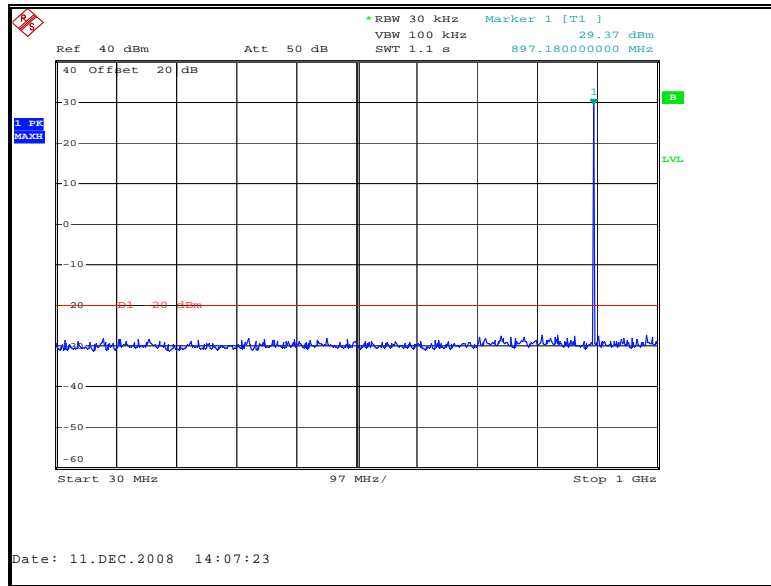

Figure 7.3.2-5: Normal Mode – 896.0125 MHz – 30MHz to 1GHz

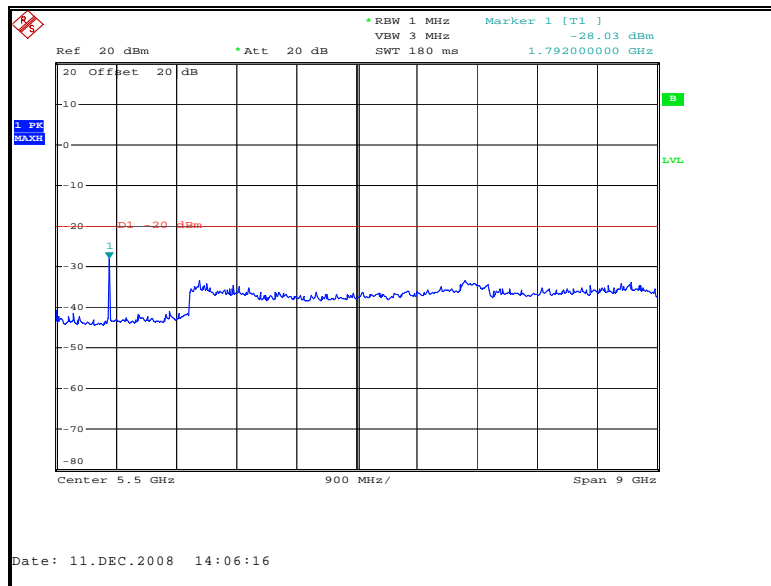

Figure 7.3.2-6: Normal Mode – 896.0125 MHz – 1GHz to 10GHz

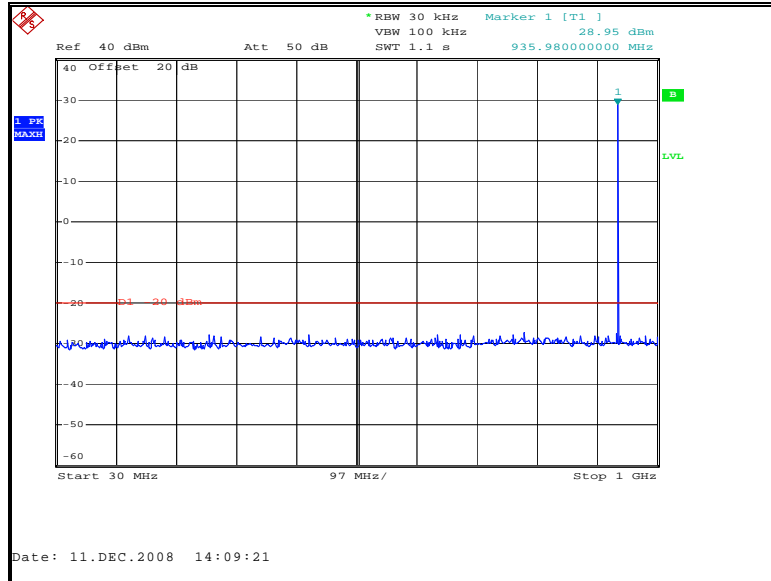

Figure 7.3.2-7: MPassMode – 935.0125 MHz – 30MHz to 1GHz

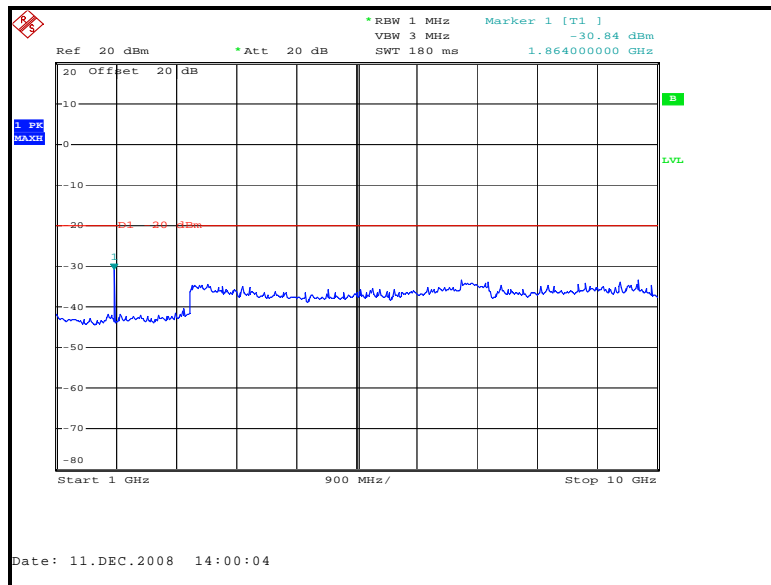

Figure 7.3.2-8: MPass Mode – 935.0125 MHz – 1GHz to 10GHz

Part 101.111 a(6), RSS-119 5.8.6

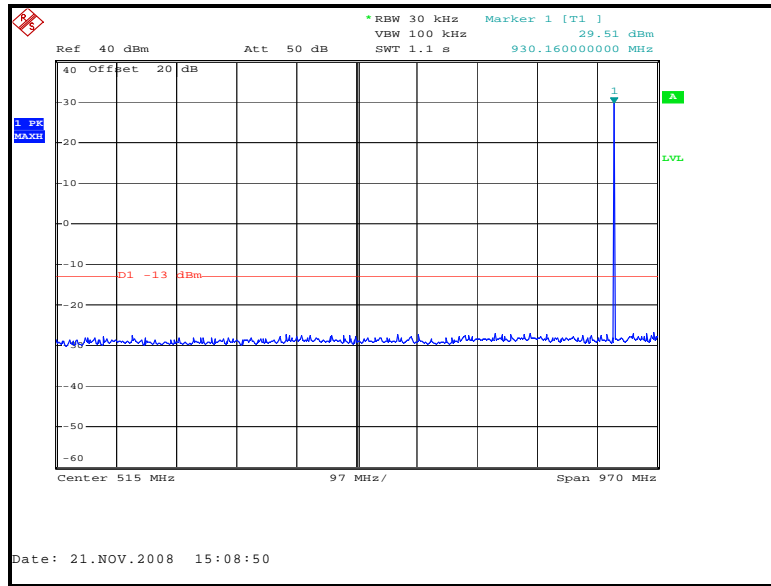

Figure 7.3.2-9: Normal Mode – 928.925 MHz – 30MHz to 1GHz

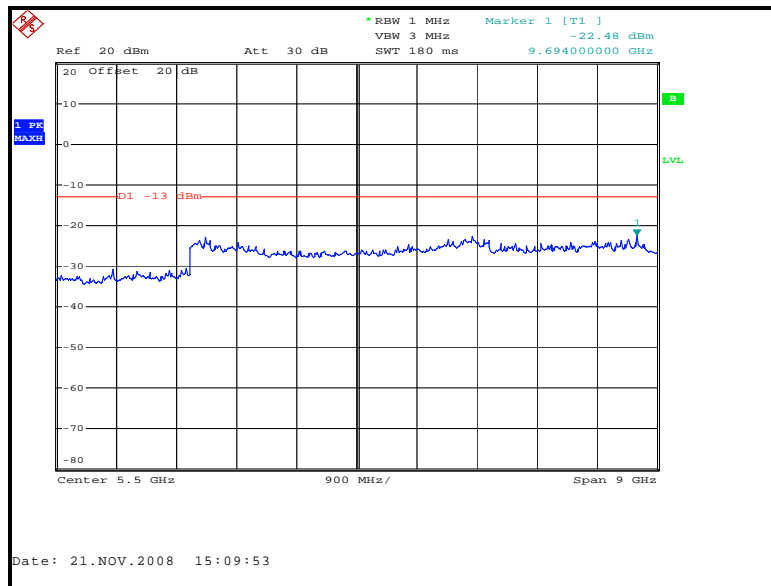

Figure 7.3.2-10: Normal Mode – 928.925 MHz – 1GHz to 10GHz

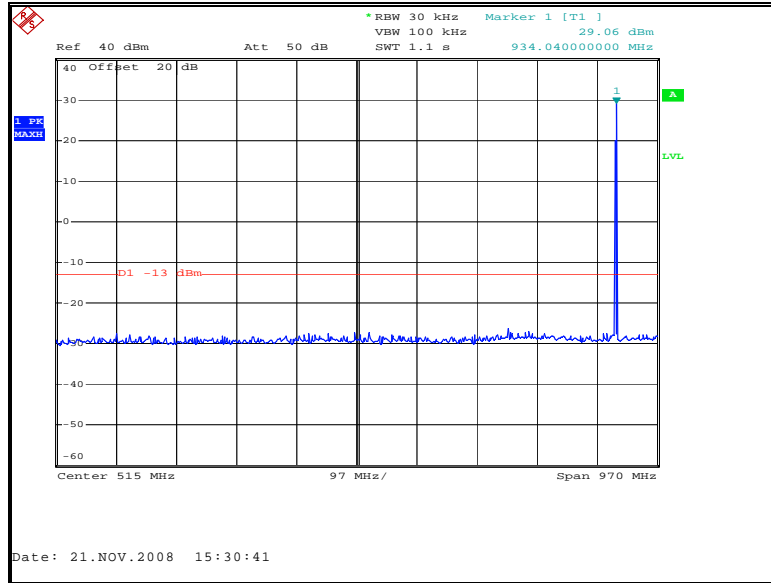

Figure 7.3.2-11: Normal Mode – 932.25 MHz – 30MHz to 1GHz

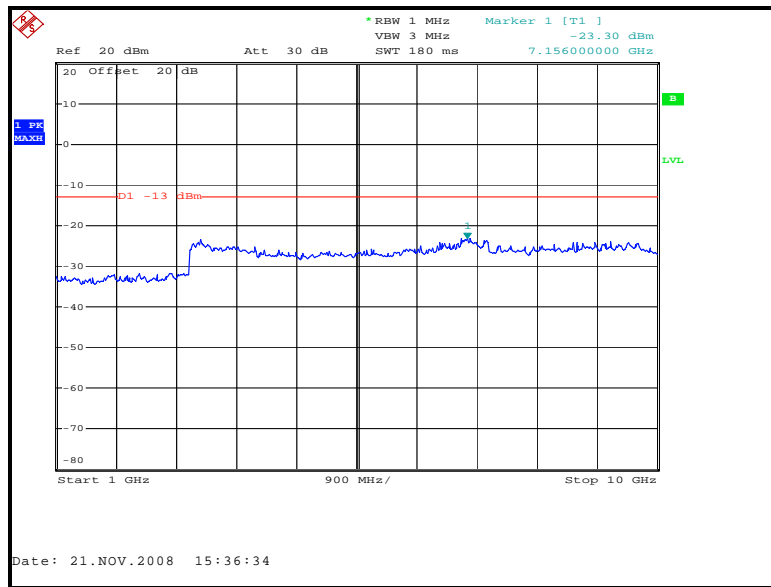

Figure 7.3.2-12: Normal Mode – 932.25 MHz – 1GHz to 10GHz

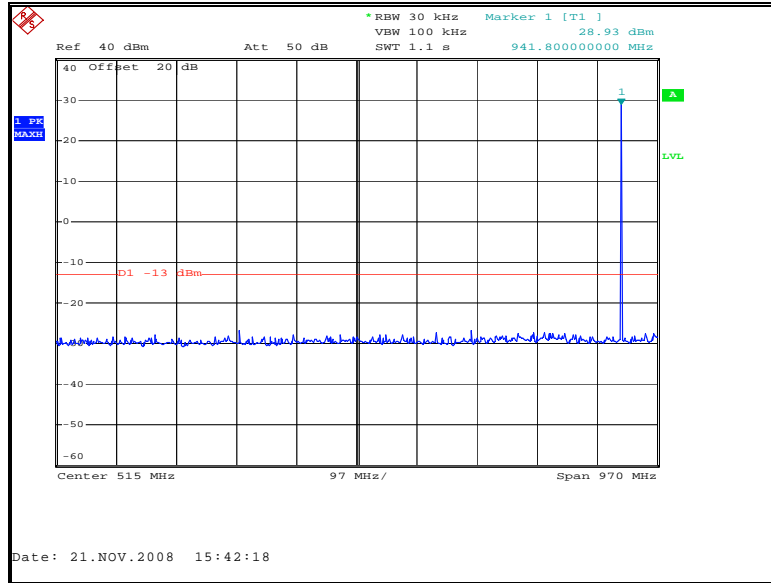

Figure 7.3.2-13: MPass Mode – 941.4875 MHz – 30MHz to 1GHz

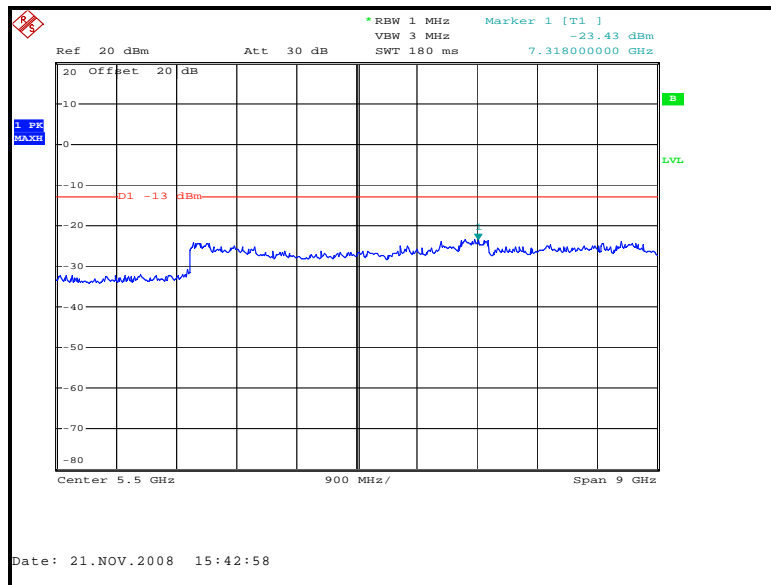

Figure 7.3.2-14: MPass Mode – 941.4875 MHz – 1GHz to 10GHz

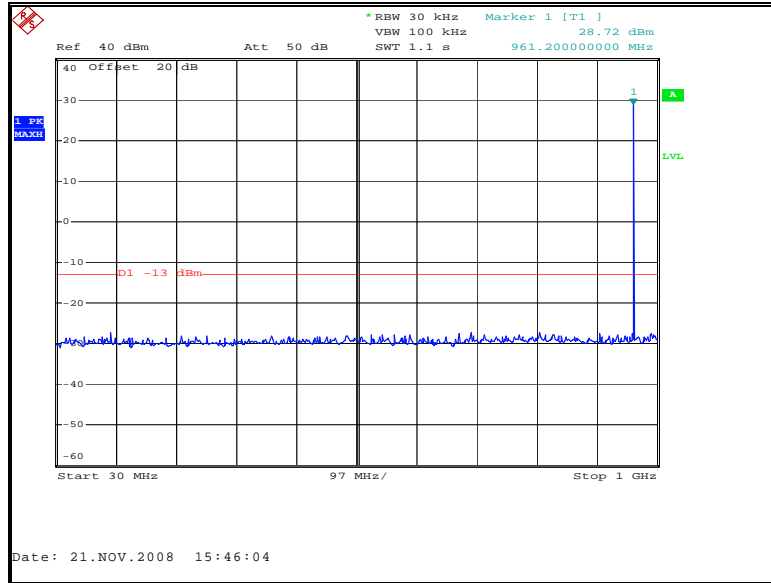

Figure 7.3.2-15: MPass Mode – 959.925 MHz – 30MHz to 1GHz

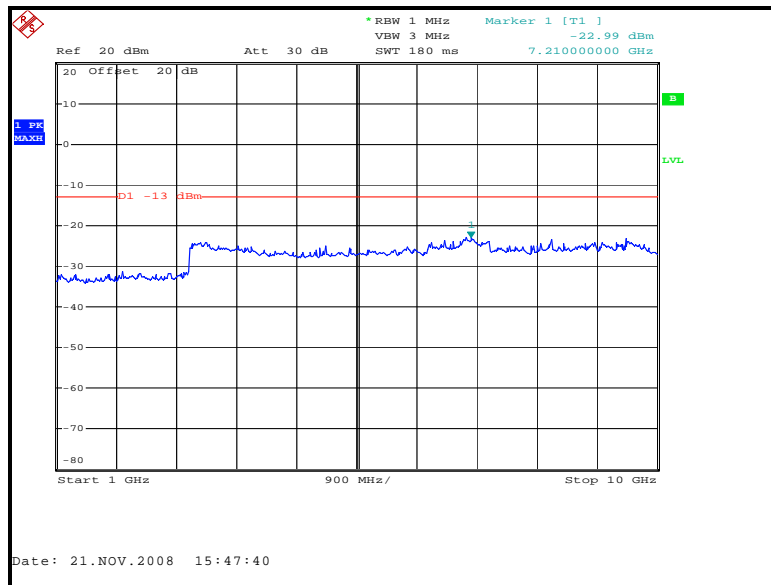

Figure 7.3.2-16: MPass Mode – 959.925 MHz – 1GHz to 10GHz

7.4 Field Strength of Spurious Emissions

7.4.1 Measurement Procedure

The equipment under test is placed in the Semi-Anechoic Chamber (described in section 2.3.1) on a wooden table at the turntable center. For each spurious emission, the antenna mast is raised and lowered from one (1) to four (4) meters and the turntable is rotated 360° and the maximum reading on the spectrum analyzer is recorded. This was repeated for both horizontal and vertical polarizations of the receive antenna.

The equipment under test is then replaced with a substitution antenna fed by a signal generator. The signal generator’s frequency is set to that of the spurious emission recorded from the equipment under test. The antenna mast is raised and lowered from one (1) to four (4) meters to obtain a maximum reading on the spectrum analyzer. The output of the signal generator is then adjusted until the reading on the spectrum analyzer matches that obtained from the equipment under test. The signal generator level is recorded. The power in dBm of each spurious emission is calculated by correcting the signal generator level for the cable loss and gain of the substitution antenna referenced to a dipole. The spectrum was investigated in accordance to CFR 47 Part 2.1057.

Data was collected at frequencies according to Section 1.3.2. Results of the test are shown below. The magnitude of all spurious emissions not reported were attenuated below the noise floor of the measurement system and therefore not specified in this report.

The equipment under test was evaluated to multiple FCC rule parts with the most stringent limit applied to all measurements.

7.4.2 Measurement Results

Part 24.133 a(1), a(2), IC RSS-134 6.3(i), (ii)

Table 7.4.2-1: Field Strength of Spurious Emissions – 901.9875 MHz – Normal Mode

Frequency (MHz)	Spectrum Analyzer Level (dBm)	Generator Level (dBm)	Antenna Polarity (H/V)	Correction Factors (dB)	Corrected Level (dBm)	Limit (dBm)	Margin (dB)
1803.975	-54.95	-54.00	H	5.10	-48.90	-20.00	28.90
1803.975	-54.8	-53	V	5.16	-47.84	-20.00	27.84
2705.9625	-55.56	-51	H	5.49	-45.51	-20.00	25.51
2705.9625	-57.77	-57	V	5.37	-51.63	-20.00	31.63
3607.95	-57.08	-55	H	6.63	-48.37	-20.00	28.37
3607.95	-57.57	-58	V	6.69	-51.31	-20.00	31.31
4509.9375	-51.85	-44	H	6.96	-37.04	-20.00	17.04
4509.9375	-54.9	-49	V	6.96	-42.04	-20.00	22.04
5411.925	-55.31	-46	H	6.75	-39.25	-20.00	19.25
5411.925	-50.86	-39	V	6.51	-32.49	-20.00	12.49
7215.9	-53.94	-39	H	5.77	-33.23	-20.00	13.23
7215.9	-55.46	-40	V	5.78	-34.22	-20.00	14.22
8117.8875	-49.7	-34	H	6.10	-27.90	-20.00	7.90
8117.8875	-55.92	-42	V	6.17	-35.83	-20.00	15.83
9019.875	-53.5	-37	H	6.13	-30.87	-20.00	10.87
9019.875	-56.98	-44	V	6.23	-37.77	-20.00	17.77

NOTE: All frequencies not listed were below the noise floor if the spectrum analyzer.

Table 7.4.2-2: Field Strength of Spurious Emissions – 930.5 MHz – MPass Mode

Frequency (MHz)	Spectrum Analyzer Level (dBm)	Generator Level (dBm)	Antenna Polarity (H/V)	Correction Factors (dB)	Corrected Level (dBm)	Limit (dBm)	Margin (dB)
1861	-53.35	-52.00	H	4.97	-47.03	-20.00	27.03
1861	-51.07	-51	V	5.04	-45.96	-20.00	25.96
2791.5	-54.95	-50	H	5.55	-44.45	-20.00	24.45
2791.5	-59.19	-60	V	5.46	-54.54	-20.00	34.54
4652.5	-59.19	-49	V	6.60	-42.40	-20.00	22.40
5583	-51.3	-42	H	6.84	-35.16	-20.00	15.16
5583	-48.37	-38	V	6.64	-31.36	-20.00	11.36
6513.5	-58.23	-50	H	5.99	-44.01	-20.00	24.01
6513.5	-59.8	-46	V	5.99	-40.01	-20.00	20.01
7444	-58.35	-52	H	6.12	-45.88	-20.00	25.88
8374.5	-56.68	-40	H	6.01	-33.99	-20.00	13.99
9305	-57.39	-40	H	6.31	-33.69	-20.00	13.69
9305	-57.39	-40	H	6.31	-33.69	-20.00	13.69

NOTE: All frequencies not listed were below the noise floor if the spectrum analyzer.

Part 90.210 (j), RSS-119 5.8.8**Table 7.4.2-3: Field Strength of Spurious Emissions – 896.0125MHz – Normal Mode**

Frequency (MHz)	Spectrum Analyzer Level (dBm)	Generator Level (dBm)	Antenna Polarity (H/V)	Correction Factors (dB)	Corrected Level (dBm)	Limit (dBm)	Margin (dB)
1792.025	-51.98	-50.00	H	5.13	-44.87	-20.00	24.87
1792.025	-56.17	-56	V	5.18	-50.82	-20.00	30.82
2688.0375	-53.91	-50	H	5.48	-44.52	-20.00	24.52
2688.0375	-55.43	-52	V	5.35	-46.65	-20.00	26.65
3584.05	-55.89	-50	H	6.68	-43.32	-20.00	23.32
3584.05	-57.06	-55	V	6.74	-48.26	-20.00	28.26
4480.0625	-51.5	-43	H	6.94	-36.06	-20.00	16.06
4480.0625	-54.39	-47	V	6.93	-40.07	-20.00	20.07
5376.075	-56.4	-44	H	6.70	-37.30	-20.00	17.30
5376.075	-53.12	-42	V	6.45	-35.55	-20.00	15.55
7168.1	-55.92	-40	H	5.69	-34.31	-20.00	14.31
7168.1	-56.6	-43	V	5.72	-37.28	-20.00	17.28
8064.1125	-49.06	-33.53	H	6.12	-27.41	-20.00	7.41
8064.1125	-54.11	-42	V	6.15	-35.85	-20.00	15.85
8960.125	-53.5	-34	H	6.10	-27.90	-20.00	7.90
8960.125	-58.27	-50	V	6.22	-43.78	-20.00	23.78

NOTE: All frequencies not listed were below the noise floor if the spectrum analyzer.

Table 7.4.2-4: Field Strength of Spurious Emissions – 935.0125MHz – MPass Mode

Frequency (MHz)	Spectrum Analyzer Level (dBm)	Generator Level (dBm)	Antenna Polarity (H/V)	Correction Factors (dB)	Corrected Level (dBm)	Limit (dBm)	Margin (dB)
1870.025	-49.05	-48.00	H	4.95	-43.05	-20.00	23.05
1870.025	-51.88	-52	V	5.03	-46.97	-20.00	26.97
2805.0375	-54.95	-55	H	5.56	-49.44	-20.00	29.44
2805.0375	-59.73	-60	V	5.48	-54.52	-20.00	34.52
4675.0625	-57.24	-48	H	6.68	-41.32	-20.00	21.32
4675.0625	-58.51	-58	V	6.54	-51.46	-20.00	31.46
5610.075	-52.21	-41	H	6.82	-34.18	-20.00	14.18
5610.075	-53.78	-45	V	6.62	-38.38	-20.00	18.38
6545.0875	-57.67	-43	H	5.95	-37.05	-20.00	17.05
7480.1	-59.42	-43	H	6.17	-36.83	-20.00	16.83
8415.1125	-53.63	-37	H	6.00	-31.00	-20.00	11.00
8415.1125	-57.75	-47	V	6.25	-40.75	-20.00	20.75

NOTE: All frequencies not listed were below the noise floor if the spectrum analyzer.

Part 101.111 a(6), RSS-119 5.8.6

Table 7.4.2-5: Field Strength of Spurious Emissions – 928.925MHz – Normal Mode

Frequency (MHz)	Spectrum Analyzer Level (dBm)	Generator Level (dBm)	Antenna Polarity (H/V)	Correction Factors (dB)	Corrected Level (dBm)	Limit (dBm)	Margin (dB)
1857.85	-47.79	-47.00	H	4.98	-42.02	-20.00	22.02
1857.85	-53.23	-53	V	5.05	-47.95	-20.00	27.95
2786.775	-54.44	-52	H	5.54	-46.46	-20.00	26.46
2786.775	-58.89	-58	V	5.46	-52.54	-20.00	32.54
4644.625	-55.61	-46	H	6.74	-39.26	-20.00	19.26
4644.625	-56.65	-55	V	6.62	-48.38	-20.00	28.38
5573.55	-51.68	-40	H	6.84	-33.16	-20.00	13.16
5573.55	-47.66	-37	V	6.64	-30.36	-20.00	10.36
6502.475	-58.71	-45	H	6.00	-39.00	-20.00	19.00
7431.4	-58.53	-43	H	6.10	-36.90	-20.00	16.90
8360.325	-54.39	-38	H	6.02	-31.98	-20.00	11.98
8360.325	-59.01	-51	V	6.23	-44.77	-20.00	24.77
9289.25	-56.04	-38	H	6.30	-31.70	-20.00	11.70
9289.25	-58.2	-48	V	6.40	-41.60	-20.00	21.60

NOTE: All frequencies not listed were below the noise floor if the spectrum analyzer.

Table 7.4.2-6: Field Strength of Spurious Emissions – 932.25MHz – Normal Mode

Frequency (MHz)	Spectrum Analyzer Level (dBm)	Generator Level (dBm)	Antenna Polarity (H/V)	Correction Factors (dB)	Corrected Level (dBm)	Limit (dBm)	Margin (dB)
1864.5	-52.72	-52.00	H	4.96	-47.04	-20.00	27.04
1864.5	-54.55	-57	V	5.04	-51.96	-20.00	31.96
2796.75	-54.39	-52	H	5.55	-46.45	-20.00	26.45
2796.75	-58.76	-59	V	5.47	-53.53	-20.00	33.53
4661.25	-58.86	-48	H	6.71	-41.29	-20.00	21.29
4661.25	-59.24	-59	V	6.58	-52.42	-20.00	32.42
5593.5	-52.82	-41	H	6.83	-34.17	-20.00	14.17
5593.5	-51.37	-42	V	6.63	-35.37	-20.00	15.37
6525.75	-58.89	-44	H	5.97	-38.03	-20.00	18.03
7458	-58.35	-43	H	6.14	-36.86	-20.00	16.86
8390.25	-56.86	-41	H	6.01	-34.99	-20.00	14.99
9322.5	-56.96	-41	H	6.32	-34.68	-20.00	14.68

NOTE: All frequencies not listed were below the noise floor if the spectrum analyzer.

Table 7.4.2-7: Field Strength of Spurious Emissions – 941.4875MHz – MPass Mode

Frequency (MHz)	Spectrum Analyzer Level (dBm)	Generator Level (dBm)	Antenna Polarity (H/V)	Correction Factors (dB)	Corrected Level (dBm)	Limit (dBm)	Margin (dB)
1882.975	-46.90	-46.00	H	4.92	-41.08	-20.00	21.08
1882.975	-51.27	-52	V	5.00	-47.00	-20.00	27.00
2824.4625	-54.88	-50	H	5.57	-44.43	-20.00	24.43
3765.95	-58.43	-52	H	6.34	-45.66	-20.00	25.66
3765.95	-57.75	-55	V	6.33	-48.67	-20.00	28.67
4707.4375	-54.42	-45	H	6.63	-38.37	-20.00	18.37
4707.4375	-55.64	-50	V	6.46	-43.54	-20.00	23.54
5648.925	-55.08	-45	H	6.80	-38.20	-20.00	18.20
5648.925	-55.94	-47	V	6.60	-40.40	-20.00	20.40
7531.9	-59.34	-45	H	6.20	-38.80	-20.00	18.80
8473.3875	-49.44	-34.2	H	5.98	-28.22	-20.00	8.22
8473.3875	-53.1	-39	V	6.26	-32.74	-20.00	12.74

NOTE: All frequencies not listed were below the noise floor if the spectrum analyzer.

Table 7.4.2-8: Field Strength of Spurious Emissions – 959.925MHz – MPass Mode

Frequency (MHz)	Spectrum Analyzer Level (dBm)	Generator Level (dBm)	Antenna Polarity (H/V)	Correction Factors (dB)	Corrected Level (dBm)	Limit (dBm)	Margin (dB)
1919.85	-45.51	-45.00	H	4.84	-40.16	-20.00	20.16
1919.85	-46.11	-46	V	4.93	-41.07	-20.00	21.07
2879.775	-53.56	-49	H	5.61	-43.39	-20.00	23.39
2879.775	-57.39	-56	V	5.56	-50.44	-20.00	30.44
3839.7	-57.77	-51	H	6.20	-44.80	-20.00	24.80
3839.7	-56.15	-52	V	6.16	-45.84	-20.00	25.84
4799.625	-53.3	-43	H	6.47	-36.53	-20.00	16.53
4799.625	-53.66	-43	V	6.23	-36.77	-20.00	16.77
5759.55	-55.59	-45	H	6.74	-38.26	-20.00	18.26
5759.55	-58.08	-53	V	6.54	-46.46	-20.00	26.46
7679.4	-56.07	-41	H	6.18	-34.82	-20.00	14.82
8639.325	-49.21	-33.38	H	6.01	-27.37	-20.00	7.37
8639.325	-54.44	-39	V	6.25	-32.75	-20.00	12.75

NOTE: All frequencies not listed were below the noise floor if the spectrum analyzer.

7.5 Frequency Stability

7.5.1 Measurement Procedure

The equipment under test is placed inside an environmental chamber. The RF output is directly coupled to the input of the measurement equipment and a power supply is attached to the primary supply voltage.

Frequency measurements were made at the extremes of the of temperature range -30°C to $+50^{\circ}\text{C}$ and at intervals of 10°C at normal supply voltage. A period of time sufficient to stabilize all components of the equipment was allowed at each frequency measurement. At a temperature 20°C the supply voltage was varied from 85% to 115% from the normal. The maximum variation of frequency was recorded.

Data was collected at a frequency for each Rule Part. Results of the test are shown below in Figures 7.5.2-1 through 7.5.2-8.

7.5.2 Measurement Results

PART 24

Frequency Stability

Frequency (MHz): 901.989834
 Deviation Limit (PPM): 1.0ppm

Temperature C	Frequency MHz	Frequency Error (PPM)	Voltage (%)	Voltage (VDC)
-30 C	901.989926	0.102	100%	20.00
-20 C	901.989794	-0.044	100%	20.00
-10 C	901.990141	0.340	100%	20.00
0 C	901.990240	0.450	100%	20.00
10 C	901.990181	0.385	100%	20.00
20 C	901.990028	0.215	100%	20.00
30 C	901.989893	0.065	100%	20.00
40 C	901.989800	-0.038	100%	20.00
50 C	901.989780	-0.060	100%	20.00
20 C	901.989900	0.073	85%	17.000
20 C	901.989870	0.040	115%	23.000

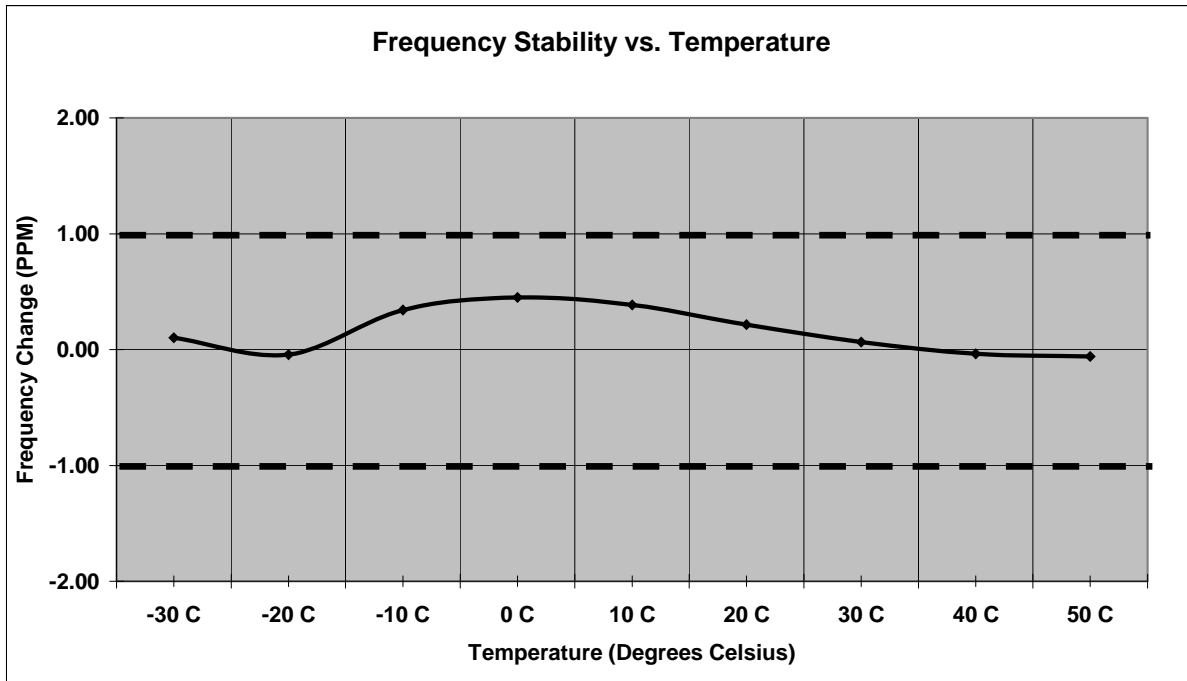

Figure 7.5.2-1: Frequency Stability – 901.9875MHz

Frequency Stability

Mode: Frequency (MHz): 930.50243
Channel: Deviation Limit (PPM): 1ppm

Temperature C	Frequency MHz	Frequency Error (PPM)	Voltage (%)	Voltage (VDC)
-30 C	930.502394	-0.039	100%	20.00
-20 C	930.502371	-0.063	100%	20.00
-10 C	930.502636	0.221	100%	20.00
0 C	930.502737	0.330	100%	20.00
10 C	930.502685	0.274	100%	20.00
20 C	930.502546	0.125	100%	20.00
30 C	930.502396	-0.037	100%	20.00
40 C	930.502260	-0.183	100%	20.00
50 C	930.502260	-0.183	100%	20.00
20 C	930.502410	-0.021	85%	17.000
20 C	930.502460	0.032	115%	23.000

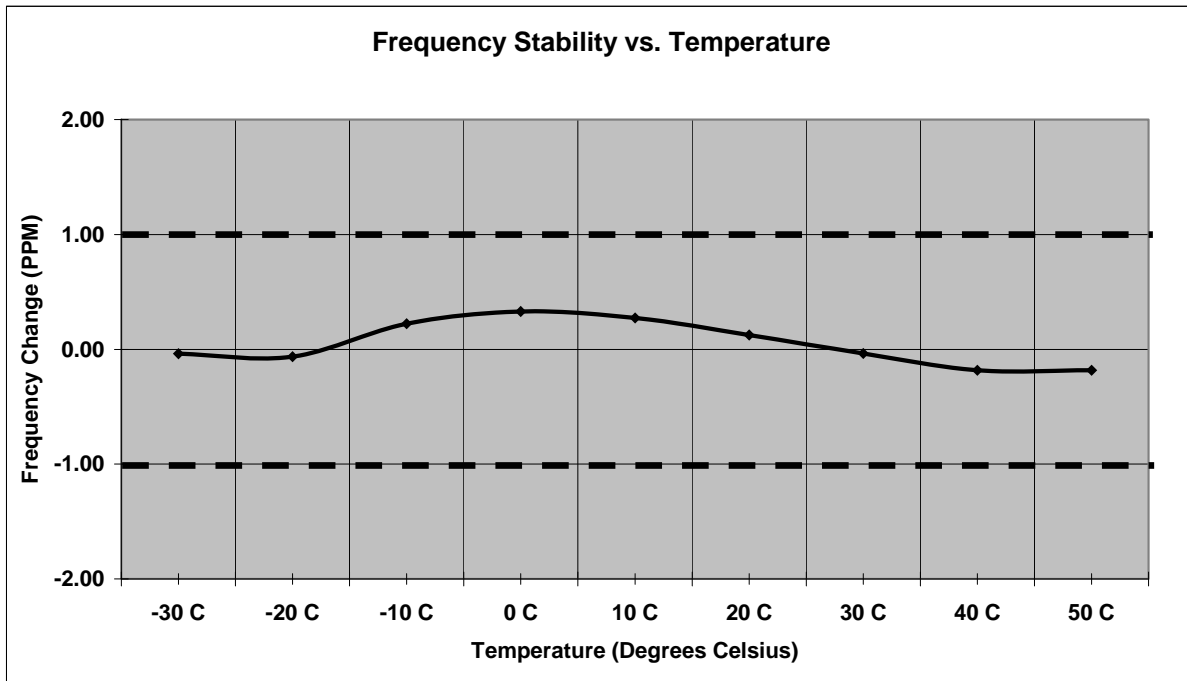

Figure 7.5.2-2: Frequency Stability – 930.5MHz

PART 90

Frequency Stability

Frequency (MHz): 896.03986
 Deviation Limit (PPM): 1ppm

Temperature C	Frequency MHz	Frequency Error (PPM)	Voltage (%)	Voltage (VDC)
-30 C	896.039944	0.094	100%	20.00
-20 C	896.039953	0.104	100%	20.00
-10 C	896.040143	0.316	100%	20.00
0 C	896.040206	0.386	100%	20.00
10 C	896.040182	0.359	100%	20.00
20 C	896.040048	0.210	100%	20.00
30 C	896.039891	0.035	100%	20.00
40 C	896.039910	0.056	100%	20.00
50 C	896.039780	-0.089	100%	20.00
20 C	896.039910	0.056	85%	17.000
20 C	896.039910	0.056	115%	23.000

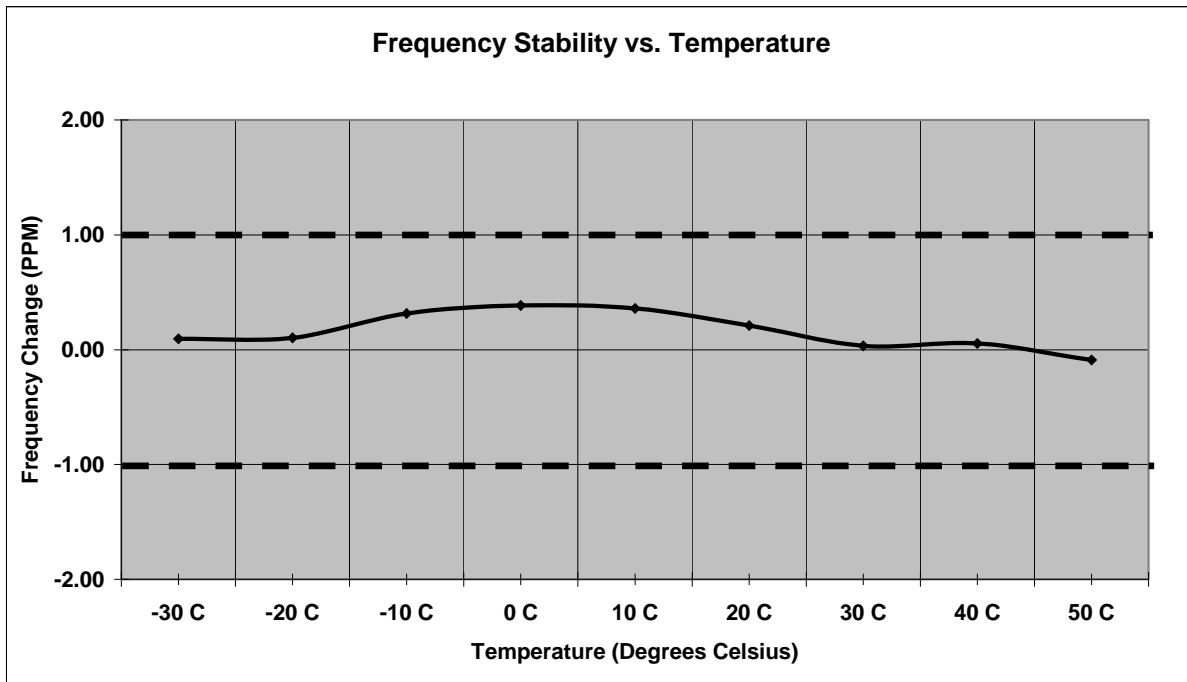

Figure 7.5.2-3: Frequency Stability – 896.0125MHz

Frequency Stability

Mode: Frequency (MHz): 935.01489
Channel: Deviation Limit (PPM): 1ppm

Temperature C	Frequency MHz	Frequency Error (PPM)	Voltage (%)	Voltage (VDC)
-30 C	935.014873	-0.018	100%	20.00
-20 C	935.014861	-0.031	100%	20.00
-10 C	935.015109	0.234	100%	20.00
0 C	935.015239	0.373	100%	20.00
10 C	935.015199	0.330	100%	20.00
20 C	935.015060	0.182	100%	20.00
30 C	935.014916	0.028	100%	20.00
40 C	935.014820	-0.075	100%	20.00
50 C	935.014810	-0.086	100%	20.00
20 C	935.014930	0.043	85%	17.000
20 C	935.014920	0.032	115%	23.000

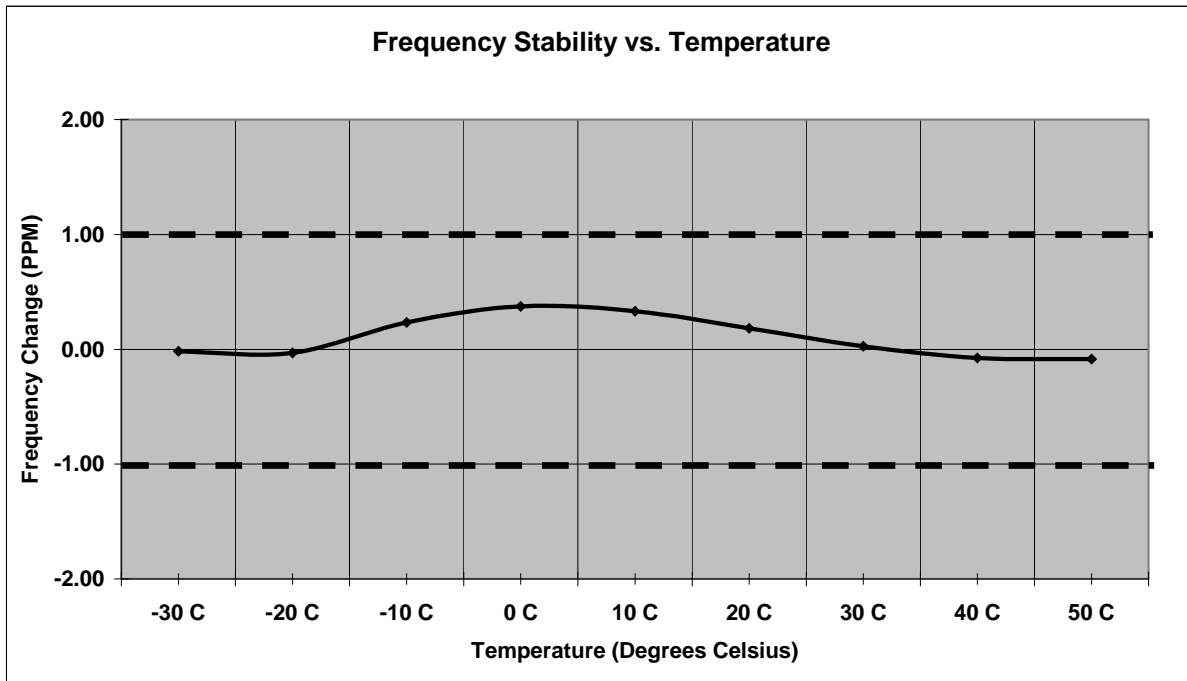

Figure 7.5.2-4: Frequency Stability – 935.0125MHz

PART 101

Frequency Stability

Mode: Frequency (MHz): 928.9274
 Channel: Deviation Limit (PPM): 1ppm

Temperature C	Frequency MHz	Frequency Error (PPM)	Voltage (%)	Voltage (VDC)
-30 C	928.927393	-0.008	100%	20.00
-20 C	928.927426	0.028	100%	20.00
-10 C	928.927614	0.230	100%	20.00
0 C	928.927724	0.349	100%	20.00
10 C	928.927691	0.313	100%	20.00
20 C	928.927558	0.170	100%	20.00
30 C	928.927412	0.013	100%	20.00
40 C	928.927310	-0.097	100%	20.00
50 C	928.927260	-0.151	100%	20.00
20 C	928.927390	-0.011	85%	17.000
20 C	928.927390	-0.011	115%	23.000

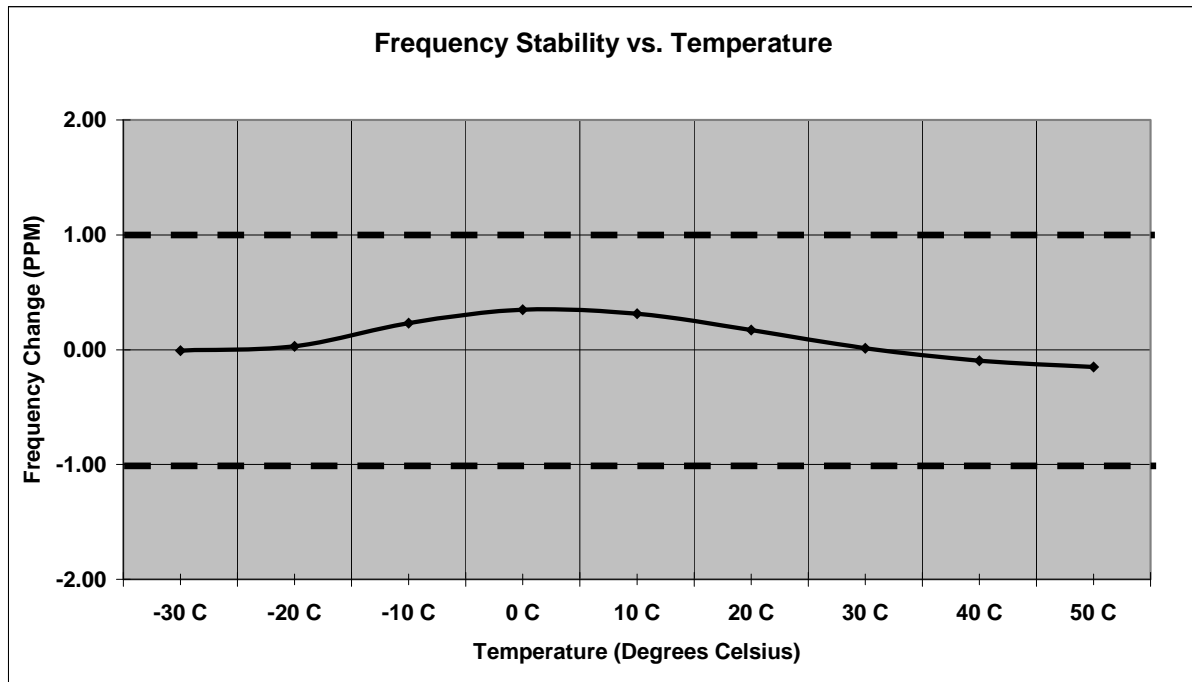

Figure 7.5.2-5: Frequency Stability – 928.925MHz

Frequency Stability

Mode: Frequency (MHz): 932.25247
 Channel: Deviation Limit (PPM): 1ppm

Temperature C	Frequency MHz	Frequency Error (PPM)	Voltage (%)	Voltage (VDC)
-30 C	932.252490	0.021	100%	20.00
-20 C	932.252421	-0.053	100%	20.00
-10 C	932.252648	0.191	100%	20.00
0 C	932.252740	0.290	100%	20.00
10 C	932.252698	0.245	100%	20.00
20 C	932.252541	0.076	100%	20.00
30 C	932.252385	-0.091	100%	20.00
40 C	932.252260	-0.225	100%	20.00
50 C	932.252280	-0.204	100%	20.00
20 C	932.252370	-0.107	85%	17.000
20 C	932.252380	-0.097	115%	23.000

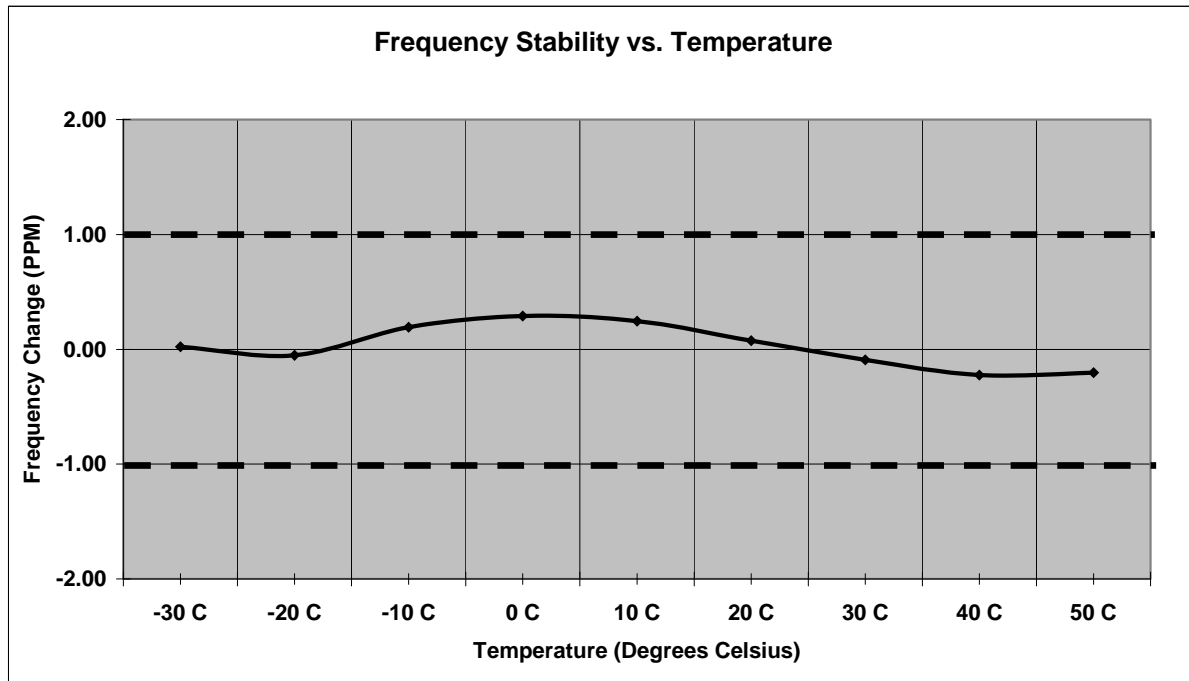

Figure 7.5.2-6: Frequency Stability – 932.5MHz

Frequency Stability

Mode: Frequency (MHz): 941.4899
 Channel: Deviation Limit (PPM): 1ppm

Temperature C	Frequency MHz	Frequency Error (PPM)	Voltage (%)	Voltage (VDC)
-30 C	941.489744	-0.166	100%	20.00
-20 C	941.489939	0.041	100%	20.00
-10 C	941.490159	0.275	100%	20.00
0 C	941.490262	0.384	100%	20.00
10 C	941.490208	0.327	100%	20.00
20 C	941.490025	0.133	100%	20.00
30 C	941.489914	0.015	100%	20.00
40 C	941.489757	-0.152	100%	20.00
50 C	941.489830	-0.074	100%	20.00
20 C	941.489910	0.011	85%	17.000
20 C	941.489920	0.021	115%	23.000

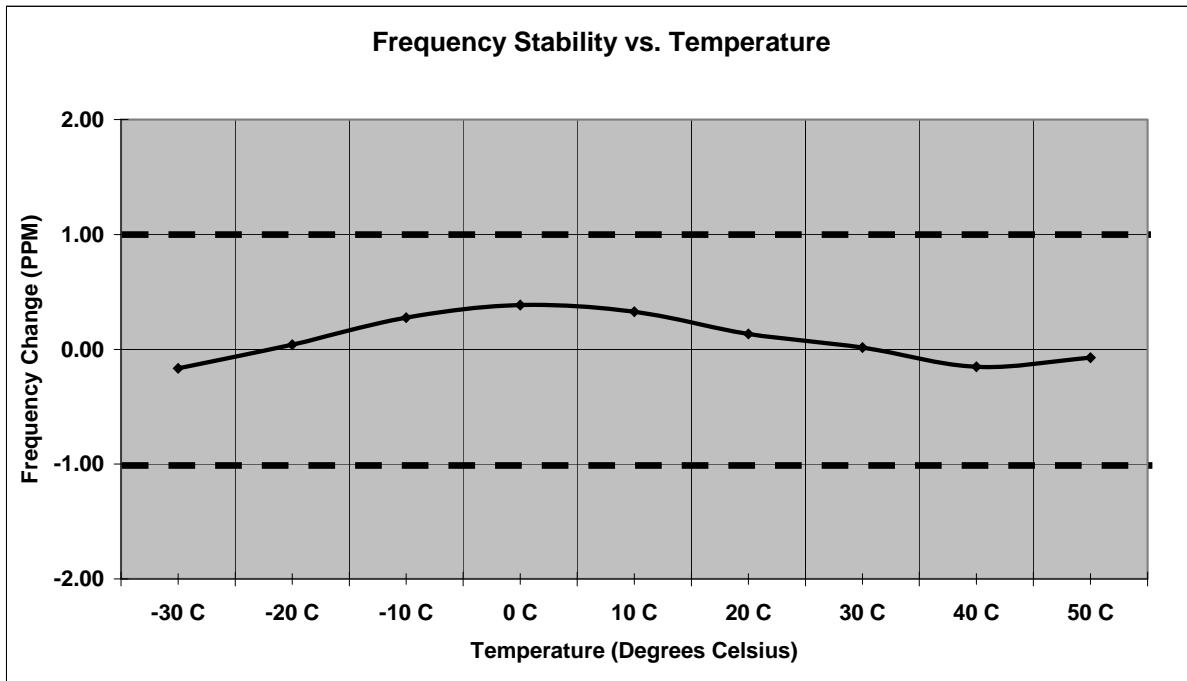

Figure 7.5.2-7: Frequency Stability – 941.4875MHz

Frequency Stability

Mode: Frequency (MHz): 959.92745
Channel: Deviation Limit (PPM): 1ppm

Temperature C	Frequency MHz	Frequency Error (PPM)	Voltage (%)	Voltage (VDC)
-30 C	959.927331	-0.124	100%	20.00
-20 C	959.927380	-0.073	100%	20.00
-10 C	959.927574	0.129	100%	20.00
0 C	959.927763	0.326	100%	20.00
10 C	959.927712	0.273	100%	20.00
20 C	959.927532	0.085	100%	20.00
30 C	959.927478	0.029	100%	20.00
40 C	959.927301	-0.155	100%	20.00
50 C	959.927290	-0.167	100%	20.00
20 C	959.927450	0.000	85%	17.000
20 C	959.927340	-0.115	115%	23.000

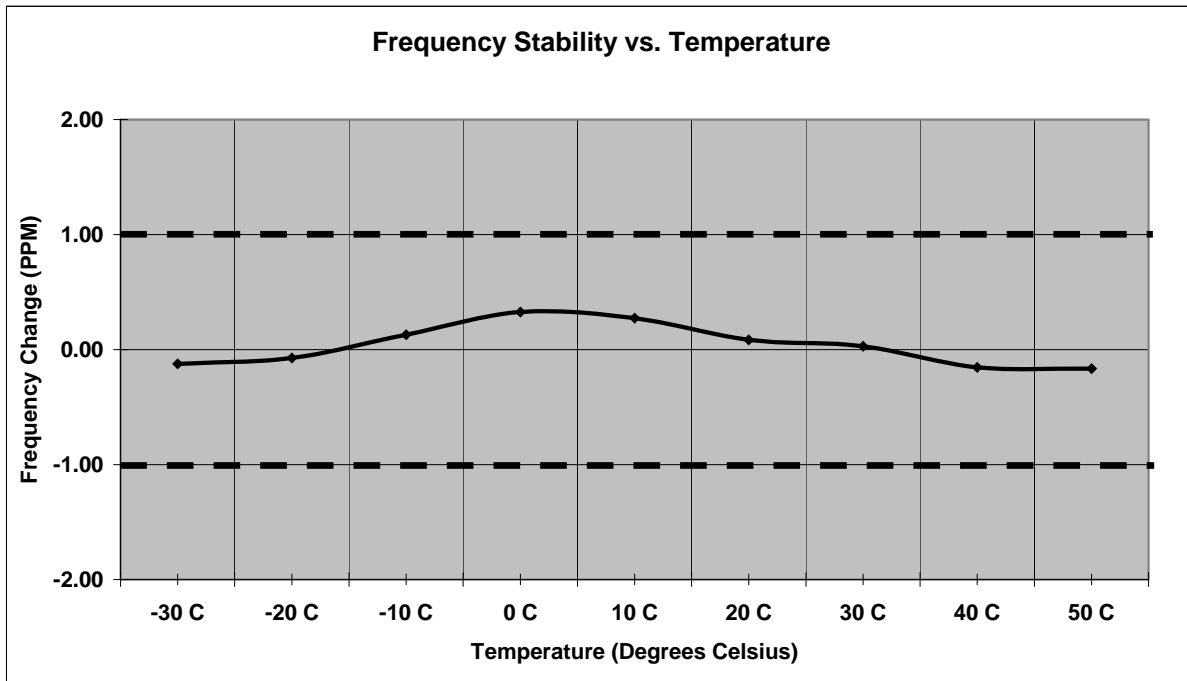

Figure 7.5.2-8: Frequency Stability – 959.9250MHz

7.6 Radiated Emissions (Unintentional Radiators) - FCC Section 15.109

7.6.1 Measurement Procedure

The equipment under test is placed in the Semi-Anechoic Chamber (described in section 2.3.1) on a wooden table at the turntable center. For each radiated emission, the antenna mast is raised and lowered from one (1) to four (4) meters and the turntable is rotated 360° to obtain a maximum peak reading on the spectrum analyzer. The radiated emissions are then measured using an EMI receiver employing a CISPR quasi-peak detector for frequencies below 1000 MHz and an Average detector function for frequencies above 1000 MHz. This repeated for both horizontal and vertical polarizations of the receive antenna.

The field strength of each radiated emission is calculated by correcting the EMI receiver level for cable loss, amplifier gain, and antenna correction factors.

$$\text{Field Strength (dBuV/m)} = \text{EMI Receiver Level (dBuV)} + \text{Cable Loss (dB)} - \text{Amplifier Gain (dB)} + \text{Antenna Correction Factor (1/m)}$$

Results of the test are shown below in Table 7.6.2-1.

7.6.2 Measurement Results

Table 7.6.2-1: Radiated Emissions Tabulated Data

Frequency (MHz)	Level (dBuV)		Antenna Polarity (H/V)	Correction Factors (dB)	Corrected Level (dBuV/m)		Limit (dBuV/m)		Margin (dB)	
	pk	Qpk/Avg			pk	Qpk/Avg	pk	Qpk/Avg	pk	Qpk/Avg
55.474		46.52	V	-19.09	-----	27.43	-----	40.0	-----	12.57
84.997		49.09	V	-17.50	-----	31.59	-----	40.0	-----	8.41
87.353		49.82	V	-16.75	-----	33.07	-----	40.0	-----	6.93
178.568		43.60	H	-15.71	-----	27.89	-----	43.5	-----	15.61
281.693		43.58	H	-11.47	-----	32.11	-----	46.0	-----	13.89
34.091		39.01	V	-10.87	-----	28.14	-----	40.0	-----	11.86
1322	38.53	27.30	V	-11.28	27.25	16.02	74.0	54.0	46.75	37.98
2266	36.89	25.67	V	-5.79	31.10	19.88	74.0	54.0	42.90	34.12

Note: Measurements taken above 2266.0 MHz were below the noise floor of the measurement equipment.

8.0 CONCLUSION

In the opinion of ACS, Inc. the model FLEXLG100, manufactured by Sensus Metering Systems, meets all the requirements of FCC Part 24, 90, and 101 as well as IC RSS-119 and RSS-134 as applicable.

End Report