



America

Modular Approval Certification Test Report

FCC ID: SDBFLEXKV2C

IC: 2220A-FLEXKV2C

**FCC Rule Part: CFR 47 Part 24 Subpart D, Part 101 Subpart C
ISED Canada's Radio Standards Specification: RSS-119, RSS-134**

TÜV SÜD Report Number: RD72140305.100

Applicant: Sensus Metering Systems, Inc.
Model: FLEXKV2C

Test Begin Date: November 6, 2018

Test End Date: December 11, 2018

Report Issue Date: January 25, 2019



FOR THE SCOPE OF ACCREDITATION UNDER LAB Code AT-1921

This report must not be used by the client to claim product certification, approval, or endorsement by ANAB, ANSI, or any agency of the Federal Government.

Prepared by:

**Ben Ford
EMC Technician
TÜV SÜD America Inc.**

Reviewed by:

**Randle Sherian
EMC Manager
TÜV SÜD America Inc.**

This test report shall not be reproduced except in full. This report may be reproduced in part with prior written consent of TÜV SÜD America Inc. The results contained in this report are representative of the sample(s) submitted for evaluation.

REVISION HISTORY

Report Number: RD72140305.100
Manufacturer: Sensus Metering Systems, Inc.
Model: FLEKKV2C

DATE	OLD REVISION	NEW REVISION	REASON	PAGES AFFECTED	APPROVED BY
January 25, 2019	---	.100	Initial Release	All	Randle Sherian

Table of Content

1.0 GENERAL -----	4
1.1 PURPOSE -----	4
1.2 PRODUCT DESCRIPTION -----	4
1.3 TEST METHODOLOGY -----	4
1.4 EMISSION DESIGNATORS -----	6
2.0 TEST FACILITIES -----	7
2.1 LOCATION -----	7
2.2 LABORATORY ACCREDITATIONS/RECOGNITIONS/CERTIFICATIONS -----	7
2.3 RADIATED & CONDUCTED EMISSIONS TEST SITE DESCRIPTION -----	8
3.0 APPLICABLE STANDARD REFERENCES -----	10
4.0 LIST OF TEST EQUIPMENT -----	11
5.0 SUPPORT EQUIPMENT -----	12
6.0 EQUIPMENT UNDER TEST SETUP BLOCK DIAGRAM -----	12
7.0 SUMMARY OF TESTS -----	13
7.1 RF POWER OUTPUT -----	13
7.2 OUT OF BAND UNWANTED EMISSIONS -----	14
7.3 99% BANDWIDTH -----	32
7.5 FIELD STRENGTH OF SPURIOUS EMISSIONS -----	60
7.6 FREQUENCY STABILITY -----	64
8.0 MEASUREMENT UNCERTAINTY -----	74
9.0 CONCLUSION -----	74

1.0 GENERAL

1.1 Purpose

The purpose of this report is to demonstrate compliance with Part 2 Subpart J, Part 24 Subpart D and Part 101 Subpart C of the FCC's Code of Federal Regulations, and ISED Canada Radio Standards Specifications RSS-119 and RSS-134.

1.2 Product Description

This transceiver is a standard FlexNet protocol with FEM controlled output capable of 1W nominal conducted output power. The modular design enables Aclara and Sensus to locate the transceiver in several standard S form meters retailed to Utilities through Aclara and Sensus.

Antenna: Integral, -0.47 dBi

Manufacturer Information:
Sensus Metering Systems, Inc.
639 Davis Drive
Morrisville, NC 27560

Test Sample Serial Numbers:

TCX0 Manufacturer	TX Radiated	RF Conducted/Frequency Stability
KDS	7	5
TXC	6	4
EPSON	8	3

Test Sample Condition: The test samples were provided in good working order with no visible defects.

1.3 Test Methodology

1.3.1 Configurations and Justification

The FLEXNET 900MHz transmitter was evaluated for radiated and RF conducted measurements for all modulation types. Where applicable, data is provided for the unit having the worst-case emissions. The KDS, EPSON, and TXC brands of TCX0s were evaluated. The worst-case TCX0 was the EPSON.

For radiated emissions, the EUT was evaluated in all 3 orthogonal orientations X, Y, and Z-planes. The results presented in this document represented the worse-case orientation, which was the X-plane

The EUT was tested standalone, and two power supplies were used to power the EUT.

The client provided a PC and mag loop antenna to configure the EUT.

1.3.2 In-Band Testing Methodology

The EUT is designed to operate in multiple bands under the requirements of CFR 47 Parts 24 and 101. The following is a list of the frequency bands of operation sorted based on the FCC rule parts in which the band is associated.

CFR Title 47 Rule Part	Frequency Band of Operation (MHz)
24D	901.0 - 902.0
24D	930.0 - 931.0
24D	940.0 - 941.0
101	928.85 - 929.0
101	932.0 - 932.5
101	941.0 - 941.5
101	952.0 – 953.0
101	959.85 - 960.0

Based on the requirements set forth in accordance 47 CFR 2.1046-2.1057 as stated above, the methodology in selecting the places to test in the available bands of operation is outlined in the following table.

CFR Title 47 Rule Part	Frequency Band of Operation (MHz)	Location in the Range of Operation	Approx. Test Freq.
24D	901.0 - 902.0	Middle	901.5000
101	928.85 - 929.0	Middle	928.9250
24D	930.0 - 931.0	Middle	930.5000
101	932.0 - 932.5	Middle	932.2500
24D	940.0 - 941.0	1 near top and 1 near bottom	940.0125
101	941.0 - 941.5		941.4875
101	952.0 – 953.0	Middle	952.5000
101	959.85 – 960.0	Middle	959.9250

1.4 Emission Designators

The FLEXKV2C transmitter produces fourteen distinct modulation types. The emission designators for the modulation types used by the FLEXKV2C transmitter were calculated using the baud rate defined in the Theory of Operation are as follows:

EMISSIONS DESIGNATORS

Mode	Emission Designator	Modulation
Normal	9K60F2D	7-FSK
Double Density	9K60F2D	13-FSK
C & I (Half Baud)	4K80F2D	7-FSK
Priority	4K80F2D	13-FSK
2SFSK (Half-Baud)	5K00F1D	2-SFSK
4SFSK (Half Baud)	5K60F1D	4-SFSK
8SFSK (Half Baud)	5K90F1D	8-SFSK
2SFSK	10K0F1D	2-SFSK
4SFSK	11K3F1D	4-SFSK
8SFSK	11K9F1D	8-SFSK
MPass (5 kbps)	5K90F1D	2-GFSK
MPass (10 kbps)	11K8F1D	2-GFSK
M4Pass (10 kbps)	4K70F1D	4-GFSK
M4Pass (20 kbps)	9K30F1D	4-GFSK

2.0 TEST FACILITIES

2.1 Location

The radiated and conducted emissions test sites are located at the following address:

TÜV SÜD America Inc.
2320 Presidential Drive, Suite 101
Durham, NC 27703
Phone: (919) 381-4235

FCC Registered Test Site Number: 637011
ISED Canada Test Site Registration Number: 20446

2.2 Laboratory Accreditations/Recognitions/Certifications

TÜV SÜD America Inc. (Durham) is accredited to ISO/IEC 17025 by ANSI-ASQ National Accreditation Board/ANAB accreditation program, and has been issued certificate number AT-1921 in recognition of this accreditation. Unless otherwise specified, all tests methods described within this report are covered under the ISO/IEC 17025 scope of accreditation.

2.3 Radiated & Conducted Emissions Test Site Description

2.3.1 Semi-Anechoic Chamber Test Site

The Semi-Anechoic Chamber Test Site consists of an 18' x 28' x 18' shielded enclosure. The chamber is lined with Samwha Electronics Co. LTD Ferrite Absorber, model number SFA300 (HSN-1). The ferrite tile is 10cm x 10 cm and weighs approximately 1.4lbs. These tiles are mounted on steel panels and installed directly on the inner walls of the chamber. On top of the ferrite tiles is DMAS HT-45 (Dutch Microwave Absorber Solutions) hybrid absorber on all walls except the wall behind the antenna mast which has a shorter DMAS HT-25 absorber.

The turntable is 1.50m in diameter and is located 150cm from the back wall of the chamber. The chamber is grounded via 1 - 8' copper ground rod, installed at the center of the back wall, it is bound to the ground plane using short #6 copper wire. The turntable is an aluminum, flush mounted table installed in an all steel frame. The table is remotely operated from inside the control room located 25' from the turntable. The turntable is electrically bonded to the surrounding ground plane via steel fingers installed on the edge of the turn table. The steel fingers make constant contact with the ground plane.

Behind the turntable is a 2' x 6' x 1.5' deep shielded pit used for support equipment if necessary. The pit is equipped with 2 - 4" PVC chase from the turntable to the pit that allow for cabling to the EUT if necessary. The underside of the turntable can be accessed from the pit so cables can be supplied to the EUT from the pit.

A diagram of the Semi-Anechoic Chamber Test Site is shown in Figure 2.3.1-1 below:

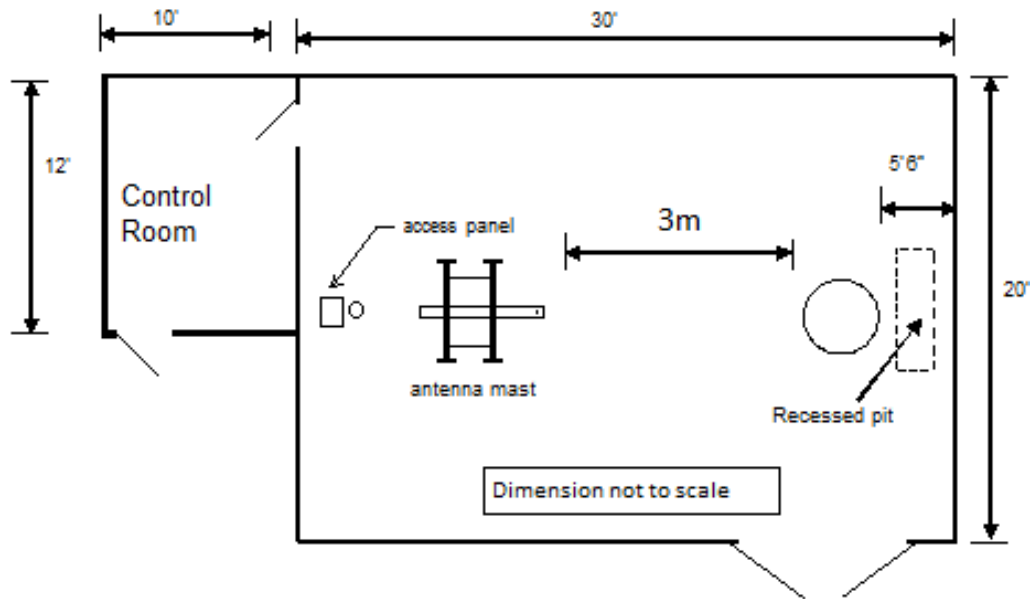

Figure 2.3.1-1: Semi-Anechoic Chamber Test Site

2.3.2 Conducted Emissions Test Site Description

The AC mains conducted EMI site is located in the main EMC lab. It consists of an 8' x 10' sheet galvanized steel horizontal ground reference plane (GRP) bonded every 6" to an 8' X 8' aluminum vertical ground plane.

A diagram of the room is shown below in figure 2.3.2-1:

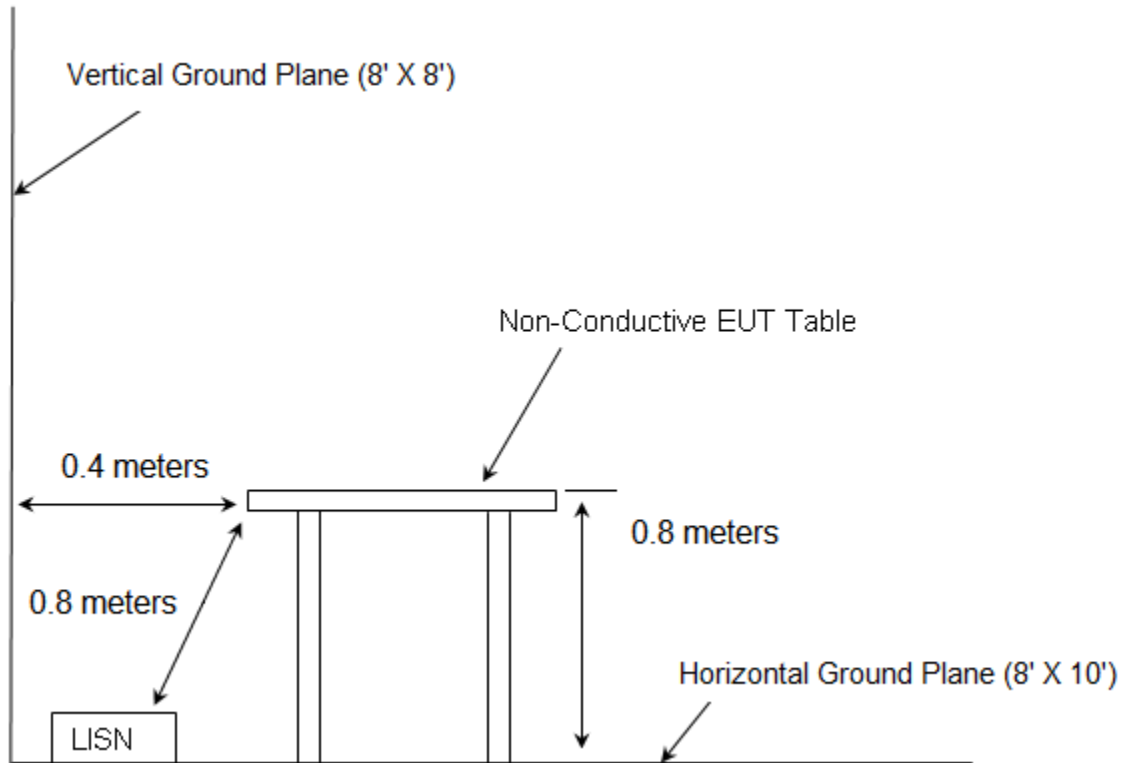

Figure 2.3.2-1: AC Mains Conducted EMI Site

3.0 APPLICABLE STANDARD REFERENCES

The following standards were used:

- ❖ ANSI C63.26-2015: Compliance Testing of Transmitters Used in Licensed Radio Services
- ❖ US Code of Federal Regulations (CFR): Title 47, Part 2, Subpart J: Equipment Authorization Procedures - 2017
- ❖ US Code of Federal Regulations (CFR): Title 47, Part 24, Subpart D: Personal Communications Services – 2017
- ❖ US Code of Federal Regulations (CFR): Title 47, Part 101, Subpart C: Fixed Microwave Services -2017
- ❖ ISED Canada Radio Standards Specification: RSS-119 - Radio Transmitters and Receivers Operating in the Land Mobile and Fixed Services in the Frequency Range 27.41-960 MHz, Issue 12, May 2015
- ❖ ISED Canada Radio Standards Specification: RSS-134 - 900 MHz Narrow Band Personal Communication Service, Issue 2, February 2016
- ❖ ISED Canada Radio Standards Specification: RSS-GEN – General Requirements for Compliance of Radio Apparatus, Issue 5, April 2018.

4.0 LIST OF TEST EQUIPMENT

The calibration interval of test equipment is annually or the manufacturer's recommendations. Where the calibration interval deviates from the annual cycle based on the instrument manufacturer's recommendations, it shall be stated below.

Table 4-1: Test Equipment Radiated Emissions

Asset ID	Manufacturer	Model #	Equipment Type	Serial #	Last Calibration Date	Calibration Due Date
DEMC0426	Thermotron	S-8 Mini Max	Environmental Chamber	25-2888-10	1/10/2018	1/10/2019
DEMC0499	EMCO	3146	Antennas	1108	5/3/2017	5/3/2019
DEMC3002	Rohde & Schwarz	ESU40	Receiver	100346	10/31/2018	10/31/2019
DEMC3006	Rohde & Schwarz	TS-PR18	Amplifiers	122006	1/10/2018	1/10/2019
DEMC3008	Rohde & Schwarz	NRP2	Meter	103131	2/15/2018	2/15/2019
DEMC3009	Rohde & Schwarz	NRP-Z81	Meter	102397	2/15/2018	2/15/2019
DEMC3012	Rohde & Schwarz	EMC32-EB	Software	100731	NCR	NCR
DEMC3013	Agilent	53132A	Meters	MY40007729	1/9/2018	1/9/2019
DEMC3014	EMCO	3115	Antennas	9901-5653	3/3/2017	3/3/2019
DEMC3016	Fei Teng Wireless Technology	HA-07M18G-NF	Antennas	2013120203	2/7/2018	2/7/2020
DEMC3020	Rohde & Schwarz	SMB100A	Signal Generators	175943	1/11/2019	1/11/2019
DEMC3029	Micro-Tronics	HPM50108	Filter	134	1/7/2018	1/7/2019
DEMC3032	Hasco, Inc.	HLL142-S1-S1-192/WA	Cables	3075	1/9/2018	1/9/2019
DEMC3035	Hasco, Inc.	HLL142-S1-S1-12	Cables	3077	1/5/2018	1/5/2019
DEMC3037	Hasco, Inc.	HLL142-S1-S1-18	Cables	6367	1/9/2018	1/9/2019
DEMC3038	Florida RF Labs	NMSE-290AW-60.0-NMSE	Cable Set	1448	1/5/2018	1/5/2019
DEMC3039	Florida RF Labs	NMSE-290AW-396.0-NMSE	Cable Set	1447	1/5/2018	1/5/2019
DEMC3041	Aeroflex Inmet	18N10W-30	Attenuator	1447	1/15/2018	1/15/2019
DEMC3045	Aeroflex Inmet	18N10W-20	Attenuator	1437	1/8/2018	1/8/2019
DEMC3053	Fluke	115	Digital Multimeter	28840861	1/9/2018	1/9/2019
DEMC3055	Rohde & Schwarz	3005	Cables	3055	1/8/2018	1/8/2019
DEMC3064	Times	LMR195	Cables	3064	8/27/2018	8/27/2019
DEMC3085	Rohde & Schwarz	FSW43	Spectrum Analyzer	103997	3/15/2018	3/15/2019

NCR = No Calibration Required

DMAS MT-25 RF absorber material was used on the floor for all final measurements above 1 GHz.

Asset DEMC3002: Firmware Version: ESU40 is 4.73 SP4

Asset DEMC3012: Software Version: EMC32-B is 9.15

Asset DEMC3020: Firmware Rev: 2.20.382.113

Asset DEMC3085: Instrument Firmware 2.90 SP1

5.0 SUPPORT EQUIPMENT

Table 5-1: EUT and Support Equipment Description

Item #	Type Device	Manufacturer	Model/Part #	Serial #
1	EUT	Sensus USA Inc.	FLEXKV2C	3
2	Power Supply	Sorensen	QRD20-4	2716
3	Power Supply	Hewlett Packard	6434B	2134A-04327

Table 5-2: Cable Description

Cable #	Cable Type	Length	Shield	Termination
A	DC Power Cable	0.95m	No	1 to 2 positive terminal
B	AC Power Cable	1.72m	No	2 to AC
C	AC Power Cable	1.72m	No	3 to AC
D	DC Power Cable	0.60m	No	2 to 3 negative terminal
E	DC Power Cable	0.95m	No	1 to 2 negative terminal
F	DC Power Cable	0.95m	No	1 to 3 positive terminal

6.0 EQUIPMENT UNDER TEST SETUP BLOCK DIAGRAM

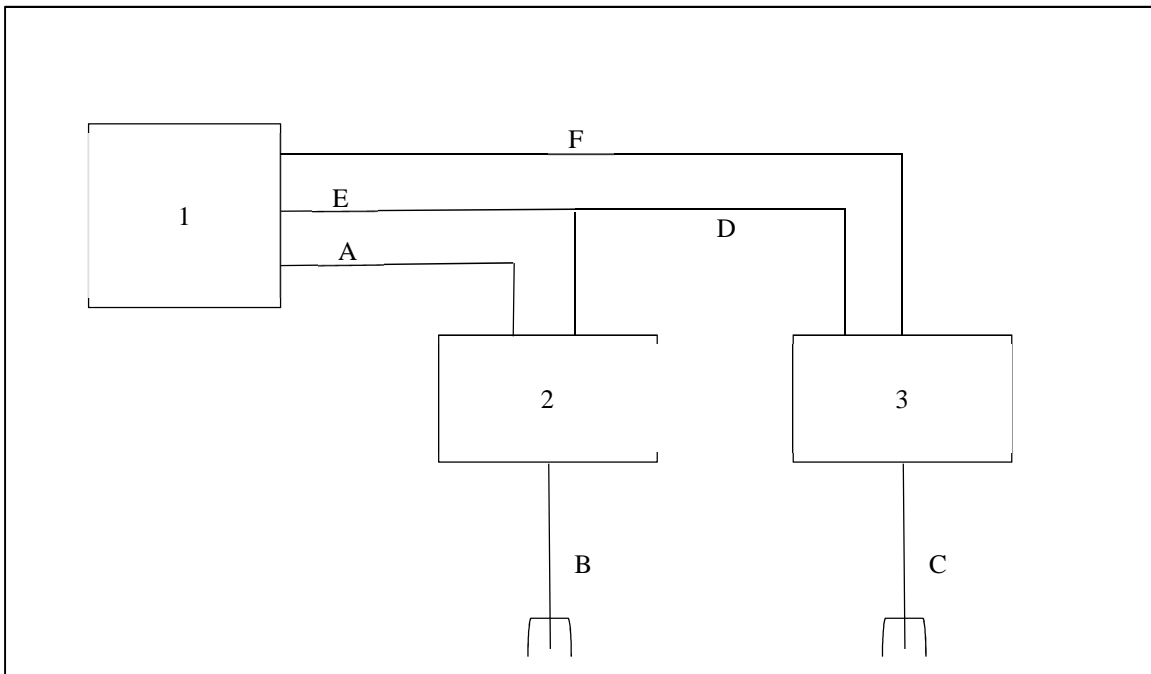

Figure 6-1: Test Setup Block Diagram

7.0 SUMMARY OF TESTS

Along with the tabular data shown below, plots were taken of all signals deemed important enough to document.

7.1 RF Power Output

7.1.1 Measurement Procedure (ANSI 63.26: 2015 Section 5.2.3.2)

The RF output of the equipment under test was directly connected to the input of a wide band RF power meter through 29.9dB of passive attenuation. The results are shown below.

Part 24.132, 101.113 (a), and ISED Canada RSS-134 4.3(a), (b) and RSS-119 5.4 – Power Output

7.1.2 Measurement Results

Performed by: Ben Ford

EPSON

Table 7.1.2-1: Peak Output Power

FCC Rule Part	Frequency (MHz)	Output Power High (dBm)	Output Power High (Watts)
24D	901.5000	31.31	1.35
24D	930.5000	30.87	1.22
24D	940.0125	30.83	1.21
101	928.9250	30.81	1.21
101	932.2500	30.92	1.24
101	941.4875	30.58	1.14
101	952.5000	30.44	1.11
101	959.9250	30.92	1.24

7.2 Out of Band Unwanted Emissions

7.2.1 Measurement Procedure (ANSI 63.26: 2015 Section 5.7.3)

The RF output of the equipment under test was directly connected to the input of the Spectrum Analyzer through 30.6dB of passive attenuation. The spectrum analyzer resolution and video bandwidths were set to 300 Hz and 1000 Hz respectively. The internal correction factors of the spectrum analyzer were employed to correct for any cable or attenuator losses. Results of the test are shown below for all modes of operation.

7.2.2 Measurement Results – Emission Masks

Performed by: Ben Ford

Part 24.133 a(1), a(2), ISED Canada RSS-134 4.4.1 (a), (b), 4.4.2 (a),(b) – Emission Limits EPSON

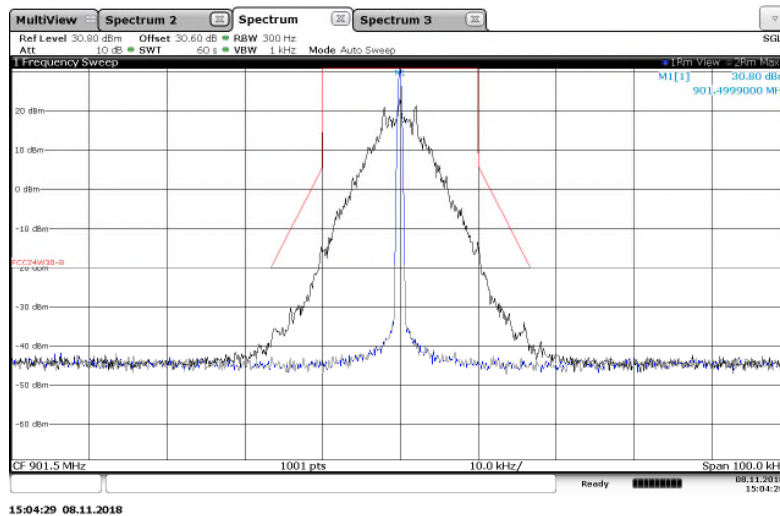

Figure 7.2.2-1: 901.5 MHz – 25 kHz Channel Spacing – Normal Mode

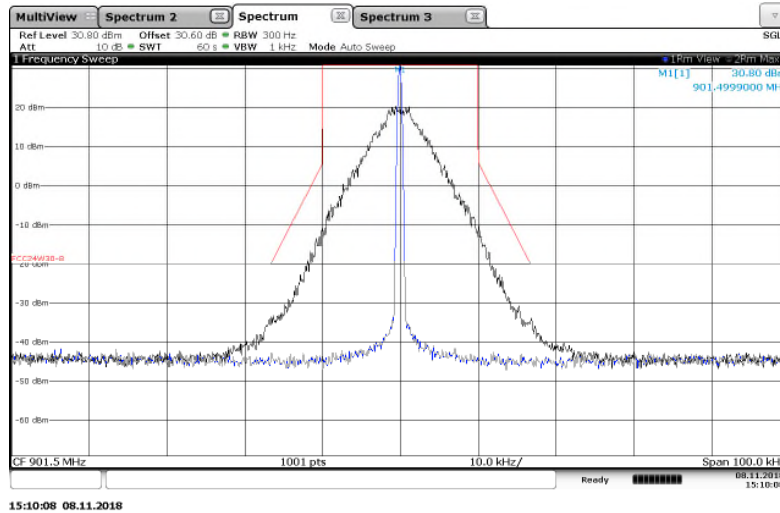

Figure 7.2.2-2: 901.5 MHz – 25 kHz Channel Spacing – Double Density Mode

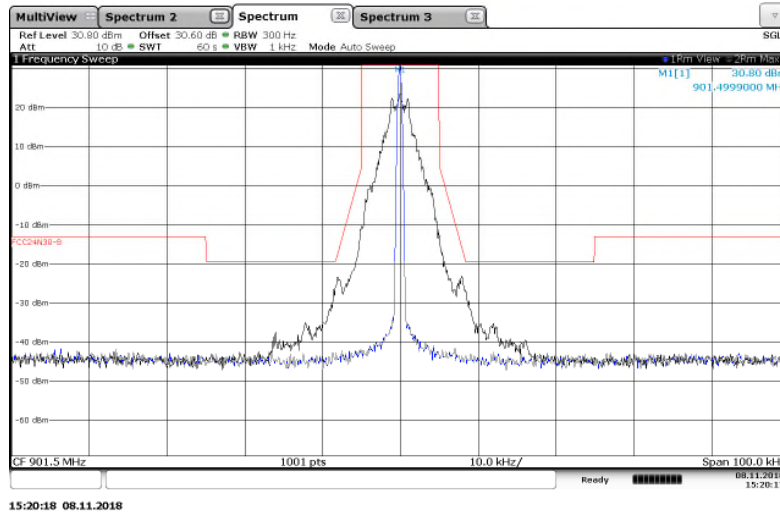

Figure 7.2.2-3: 901.5 MHz – 12.5 kHz Channel Spacing – C&I (Half Baud) Mode

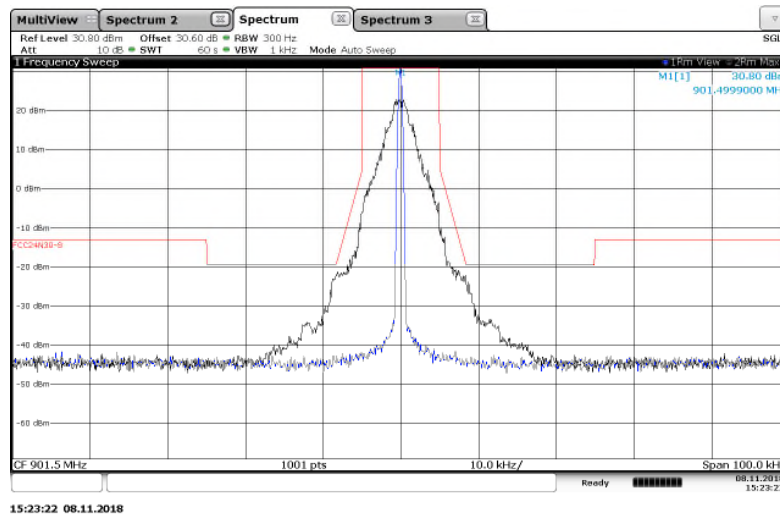

Figure 7.2.2-4: 901.5 MHz – 12.5 kHz Channel Spacing – Priority Mode

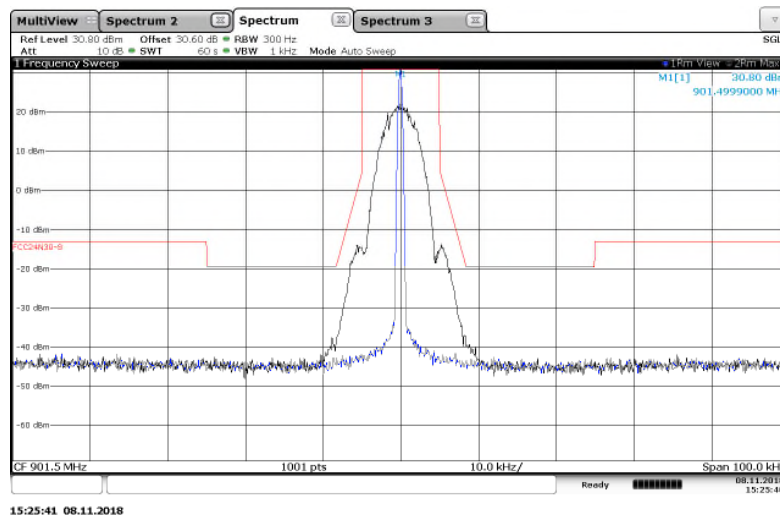

Figure 7.2.2-5: 901.5 MHz – 12.5 kHz Channel Spacing – 2FSK (Half Baud) Mode

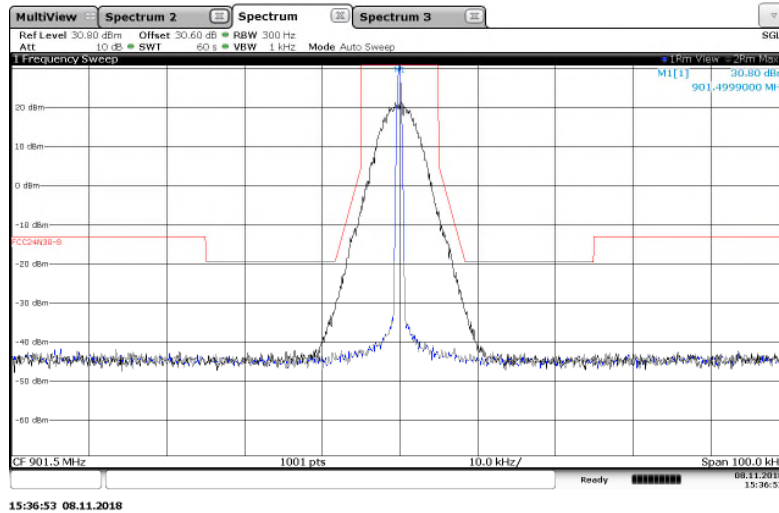

Figure 7.2.2-6: 901.5 MHz – 12.5 kHz Channel Spacing – 4FSK (Half Baud) Mode

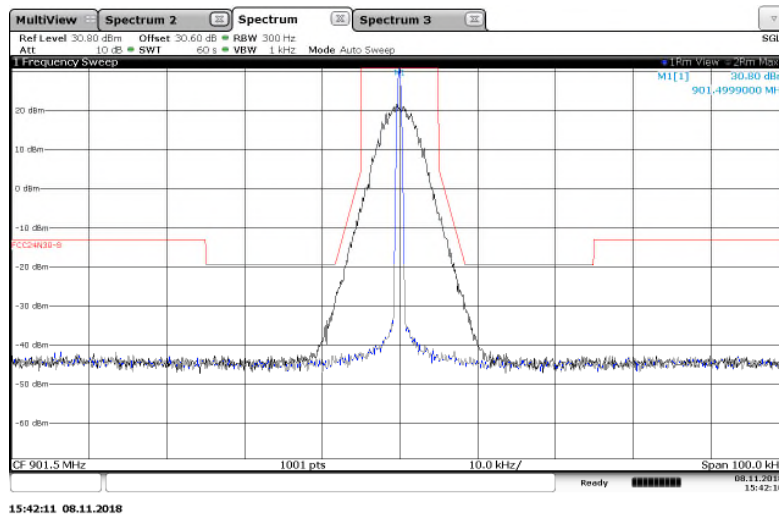

Figure 7.2.2-7: 901.5 MHz – 12.5 kHz Channel Spacing – 8FSK (Half Baud) Mode

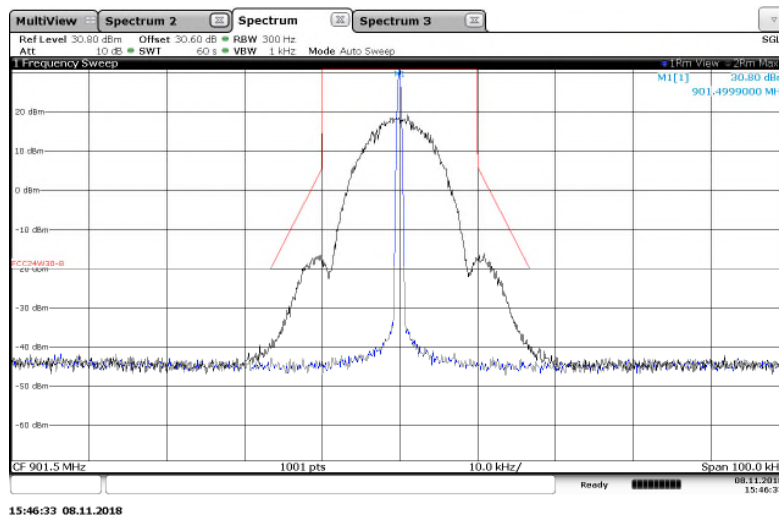

Figure 7.2.2-8: 901.5 MHz – 25 kHz Channel Spacing – 2FSK Mode

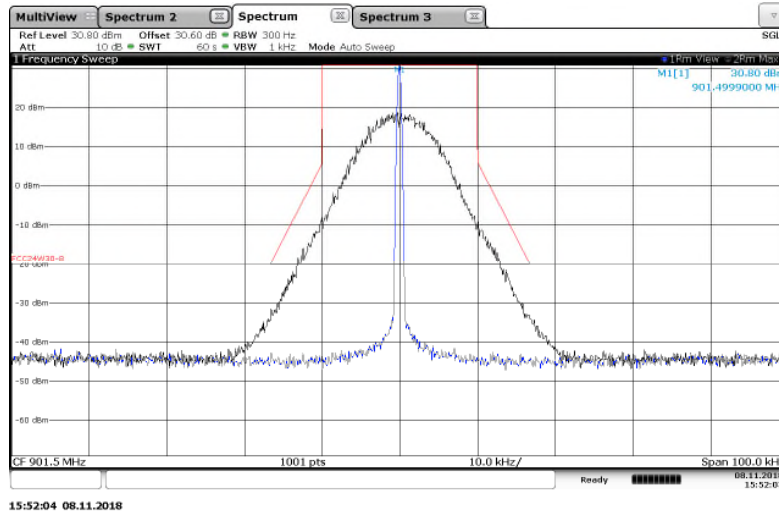

Figure 7.2.2-9: 901.5 MHz – 25 kHz Channel Spacing – 4FSK Mode

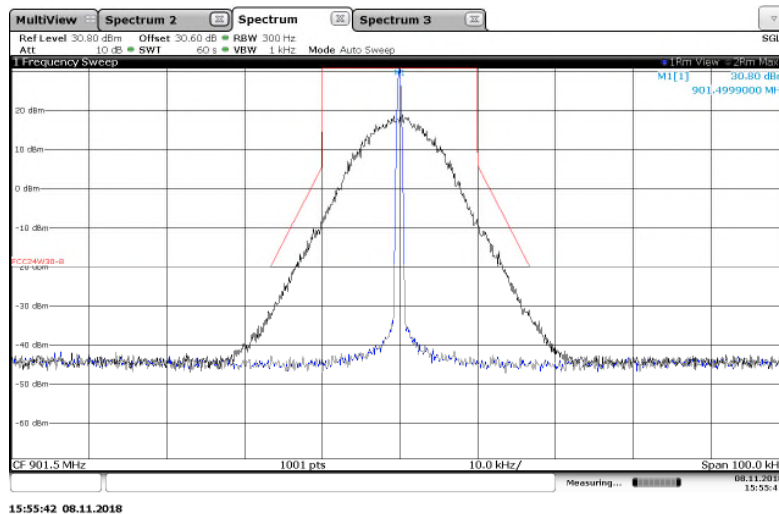

Figure 7.2.2-10: 901.5 MHz – 25 kHz Channel Spacing – 8FSK Mode

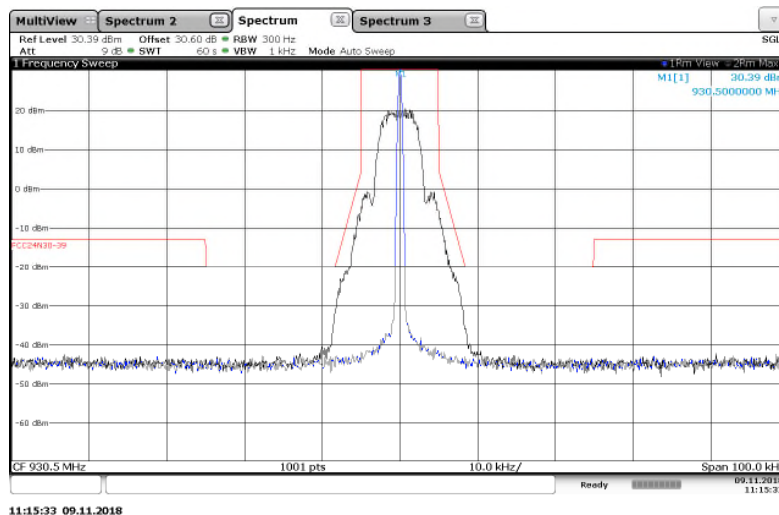

Figure 7.2.2-11: 930.5 MHz – 12.5 kHz Channel Spacing – mPass 5k Mode

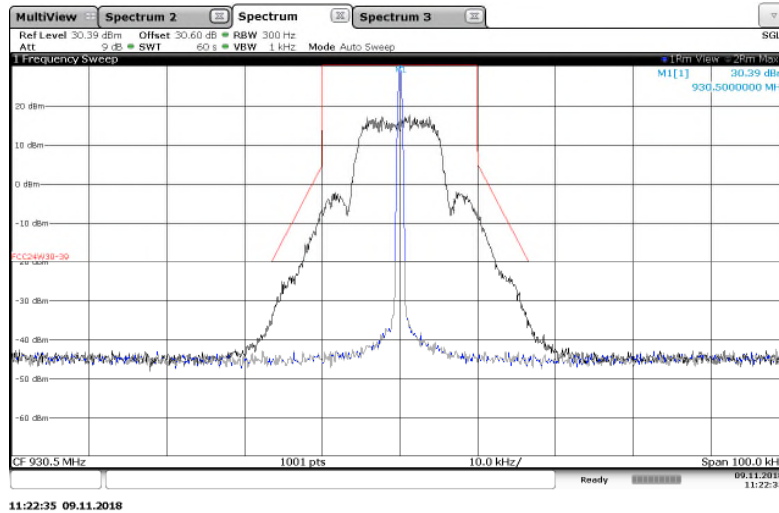

Figure 7.2.2-12: 930.5 MHz – 25 kHz Channel Spacing – mPass 10k Mode

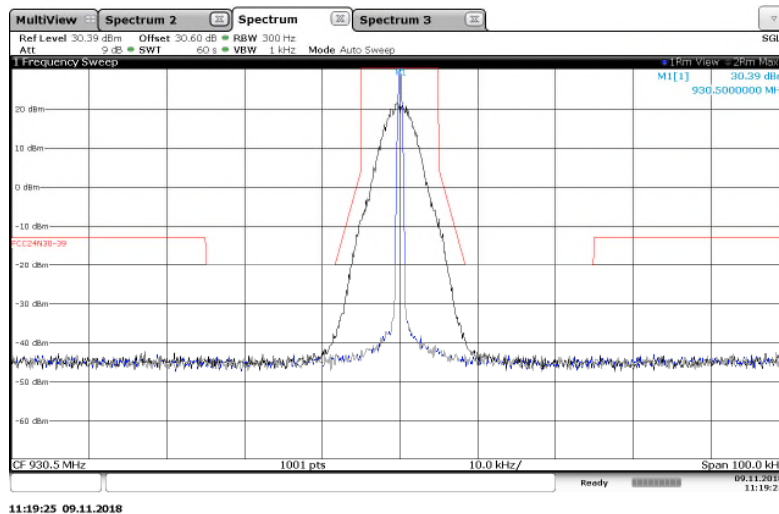

Figure 7.2.2-13: 930.5 MHz – 12.5 kHz Channel Spacing – m4Pass 10k Mode

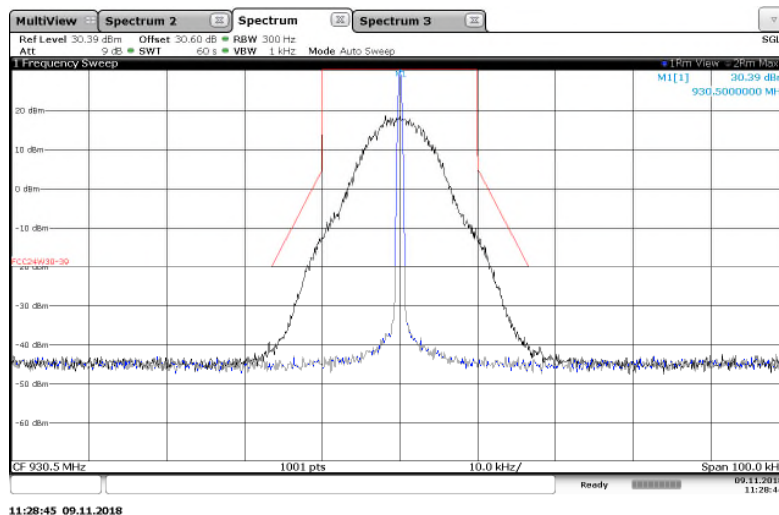

Figure 7.2.2-14: 930.5 MHz – 25 kHz Channel Spacing – m4Pass 20k Mode

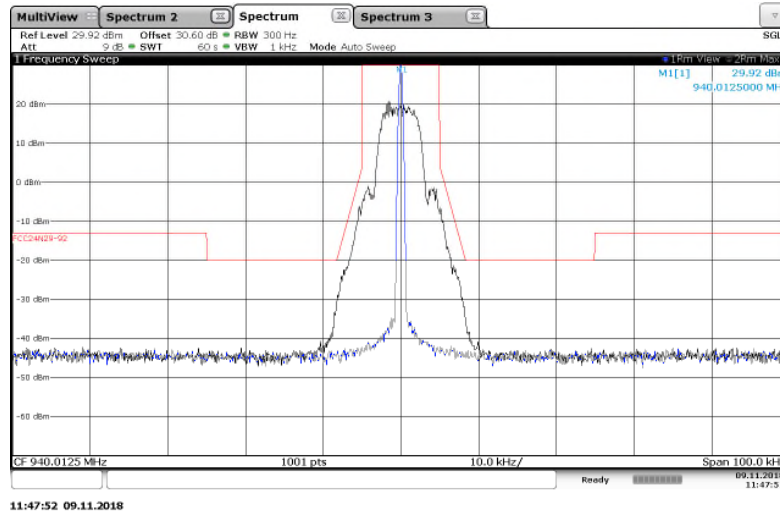

Figure 7.2.2-15: 940.0125 MHz – 12.5 kHz Channel Spacing – mPass 5k Mode

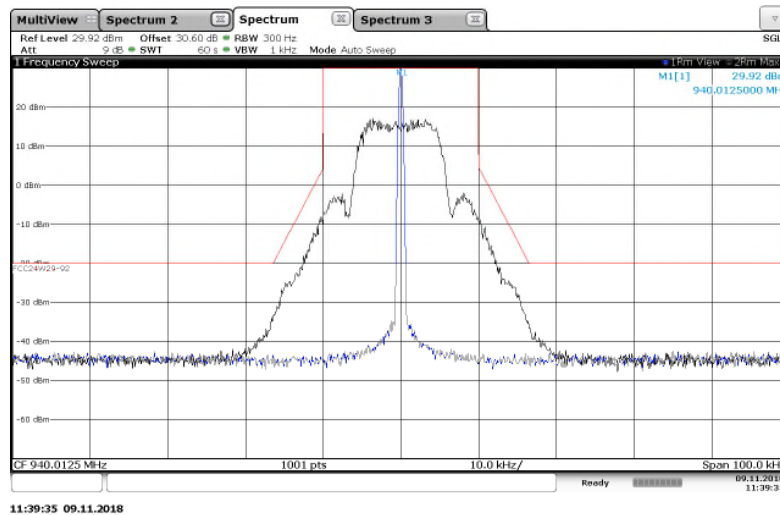

Figure 7.2.2-16: 940.0125 MHz – 25 kHz Channel Spacing – mPass 10k Mode

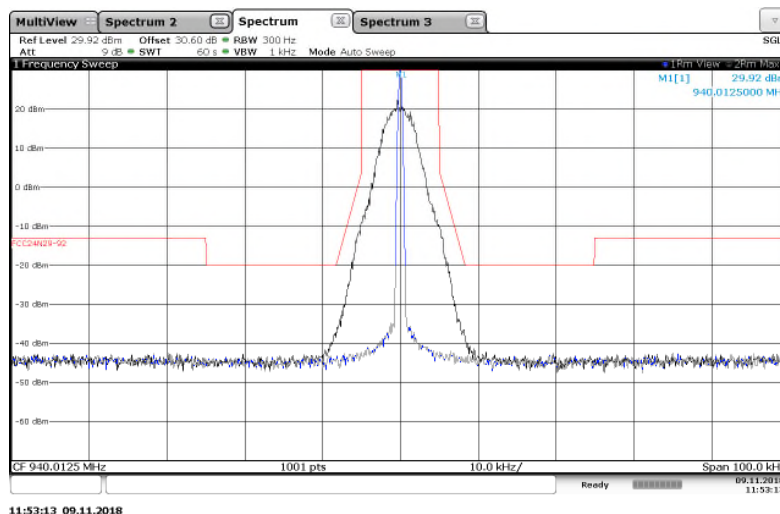

Figure 7.2.2-17: 940.0125 MHz – 25 kHz Channel Spacing – m4Pass 10k Mode

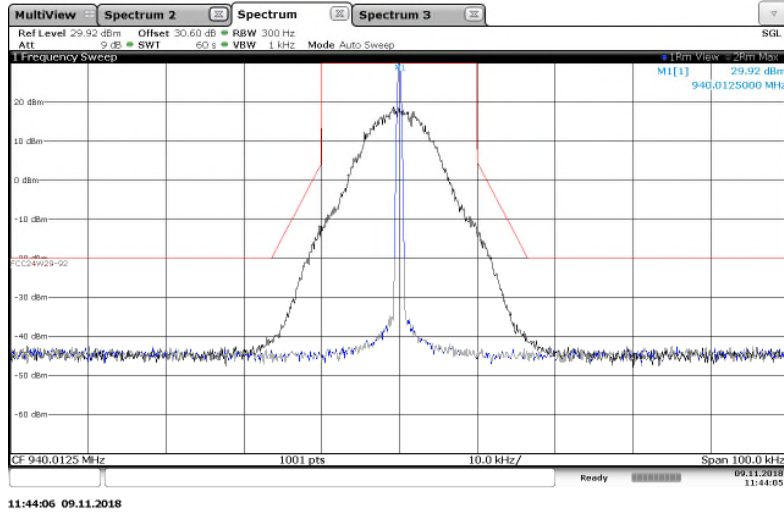

Figure 7.2.2-18: 940.0125 MHz – 25 kHz Channel Spacing – m4Pass 20k Mode

Part 101.111 a(5), a(6), RSS-119 5.8.6 (FCC Part 101.111 a(5) a(6) provides worst case)

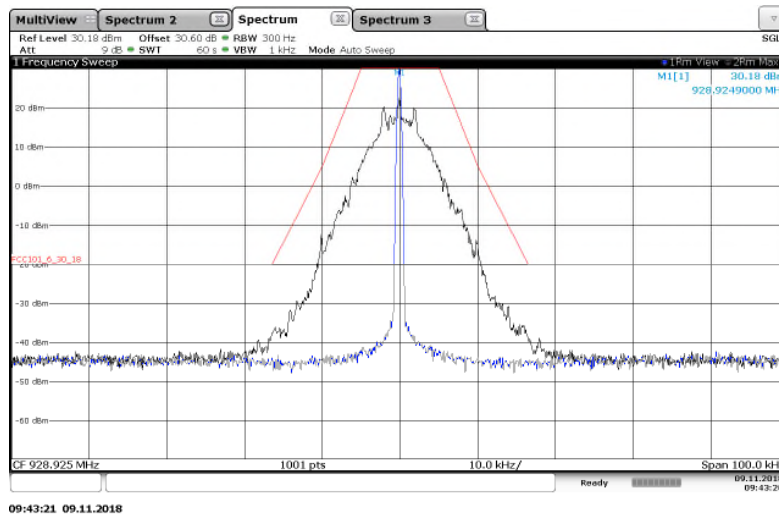

Figure 7.2.2-19: 928.925 MHz – 25 kHz Channel Spacing – Normal Mode

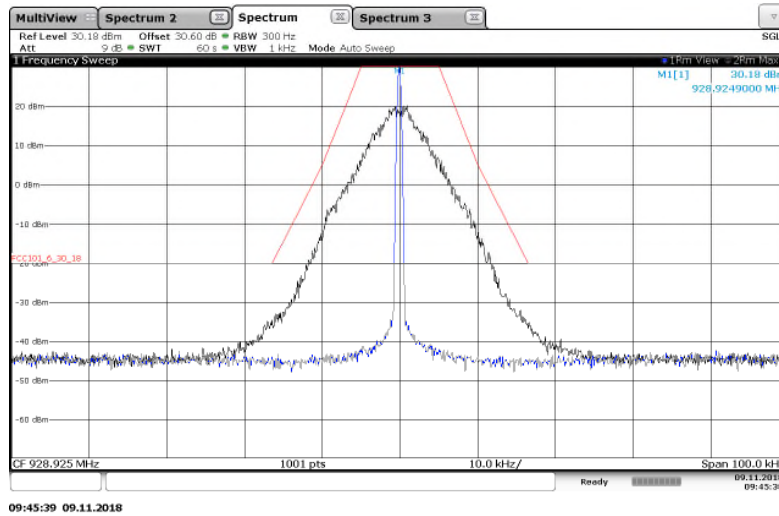

Figure 7.2.2-20: 928.925 MHz – 25 kHz Channel Spacing – Double Density Mode

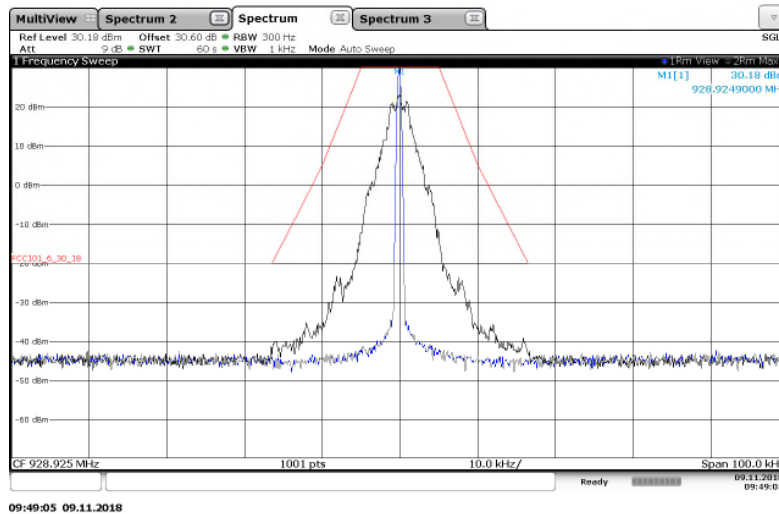

Figure 7.2.2-21: 928.925 MHz – 25 kHz Channel Spacing – C&I (Half Baud) Mode

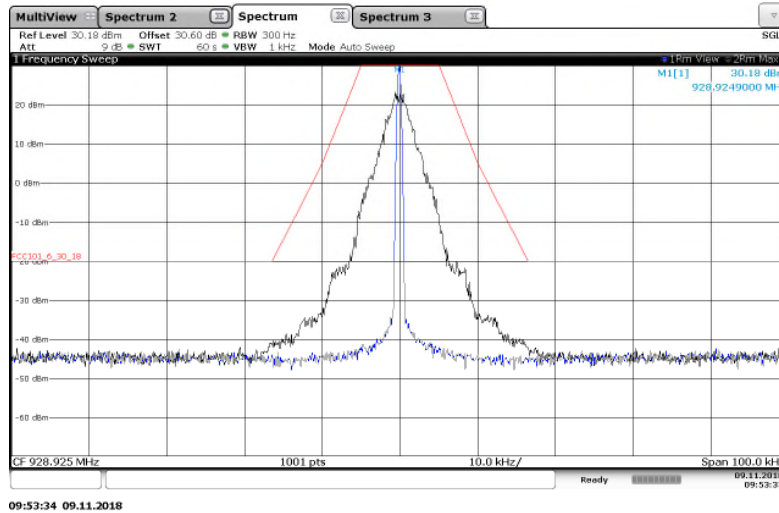

Figure 7.2.2-22: 928.925 MHz – 25 kHz Channel Spacing – Priority Mode

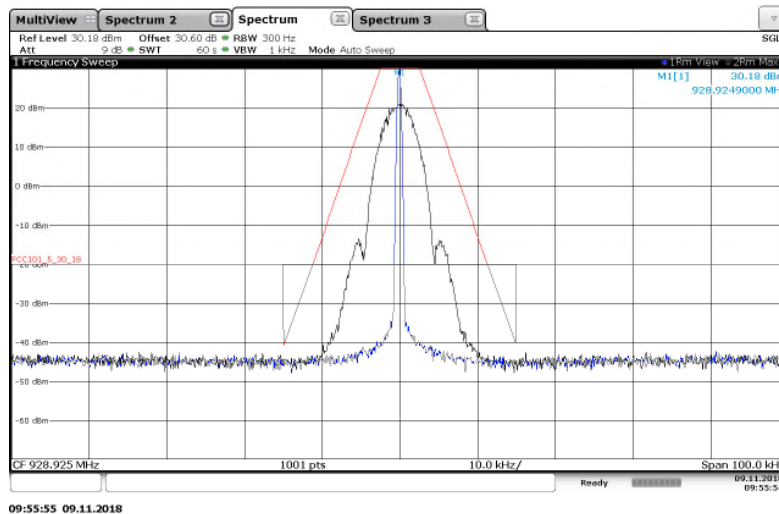

Figure 7.2.2-23: 928.925 MHz – 12.5 kHz Channel Spacing – 2SFSK (Half Baud) Mode

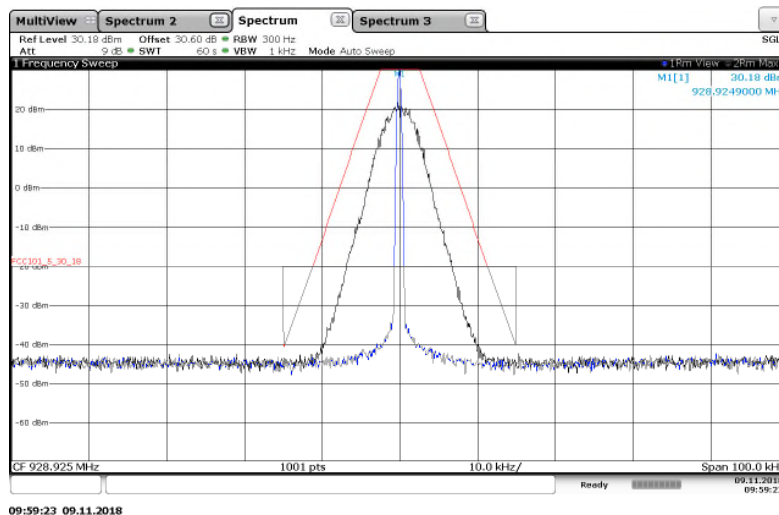

Figure 7.2.2-24: 928.925 MHz – 12.5 kHz Channel Spacing – 4SFSK (Half Baud) Mode

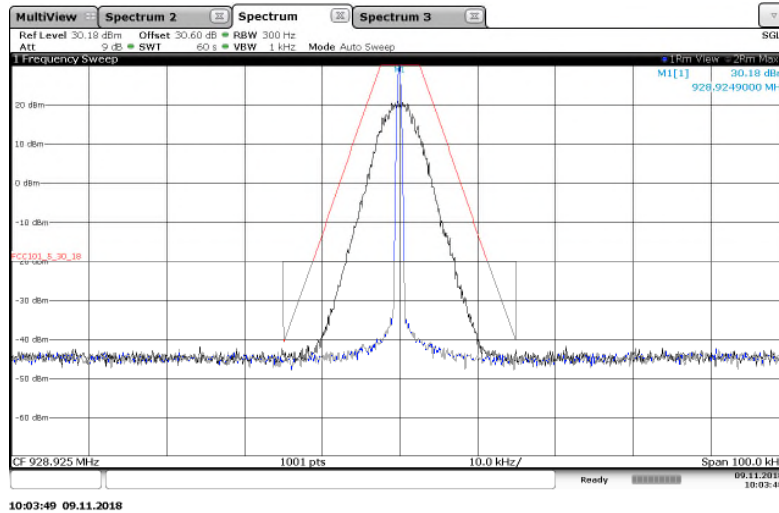

Figure 7.2.2-25: 928.925 MHz – 12.5 kHz Channel Spacing – 8FSK (Half Baud) Mode

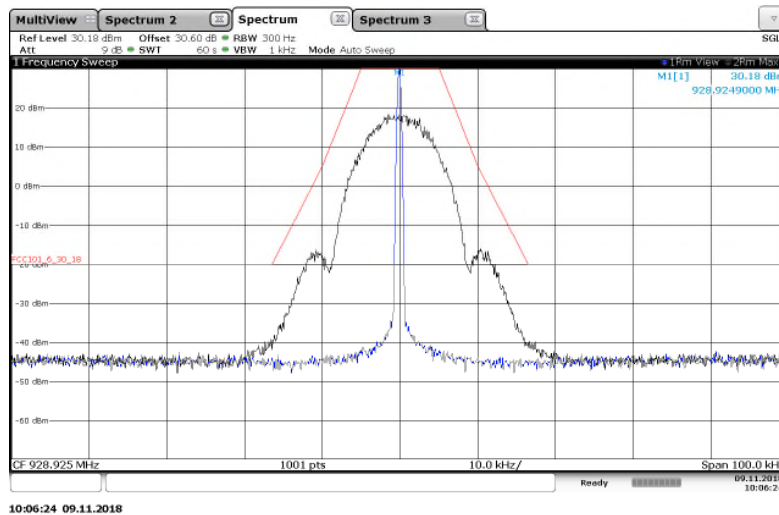

Figure 7.2.2-26: 928.925 MHz – 25 kHz Channel Spacing – 2FSK Mode

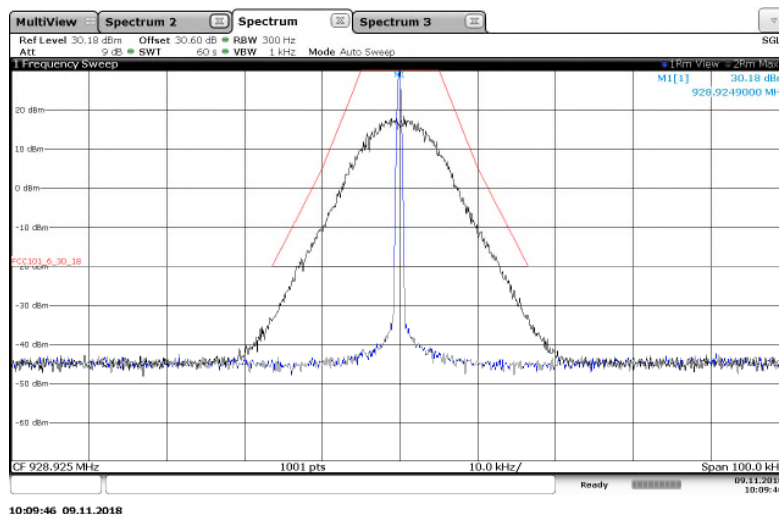

Figure 7.2.2-27: 928.925 MHz – 25 kHz Channel Spacing – 4FSK Mode

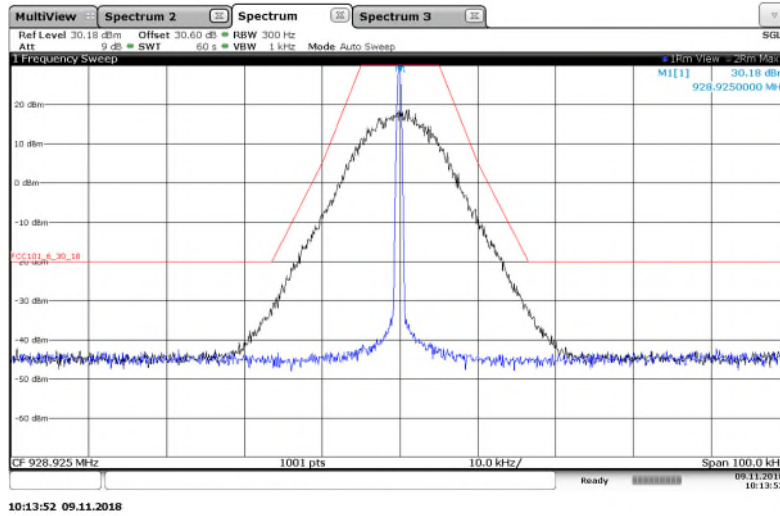

Figure 7.2.2-28: 928.925 MHz – 25 kHz Channel Spacing – 8FSK Mode

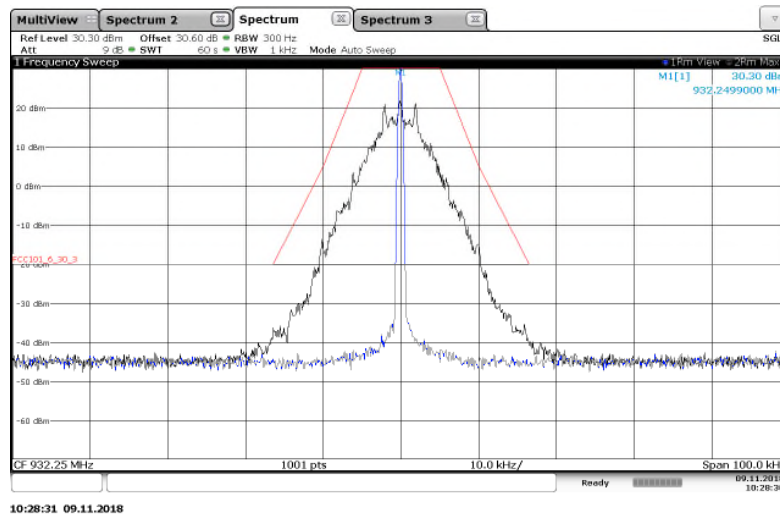

Figure 7.2.2-29: 932.25 MHz – 25 kHz Channel Spacing – Normal Mode

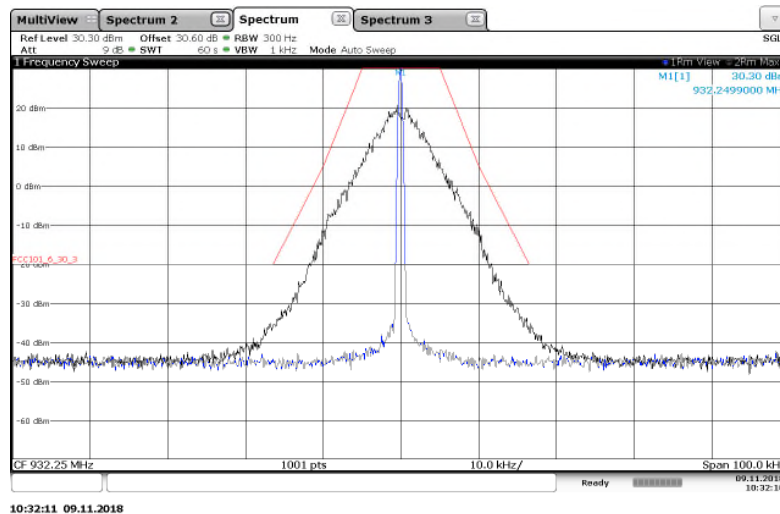

Figure 7.2.2-30: 932.25 MHz – 25 kHz Channel Spacing – Double Density Mode

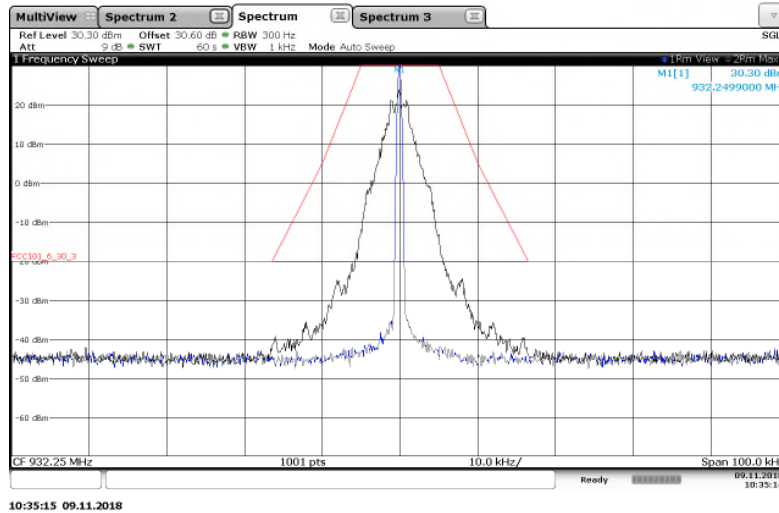

Figure 7.2.2-31: 932.25 MHz – 25 kHz Channel Spacing – C&I (Half Baud) Mode

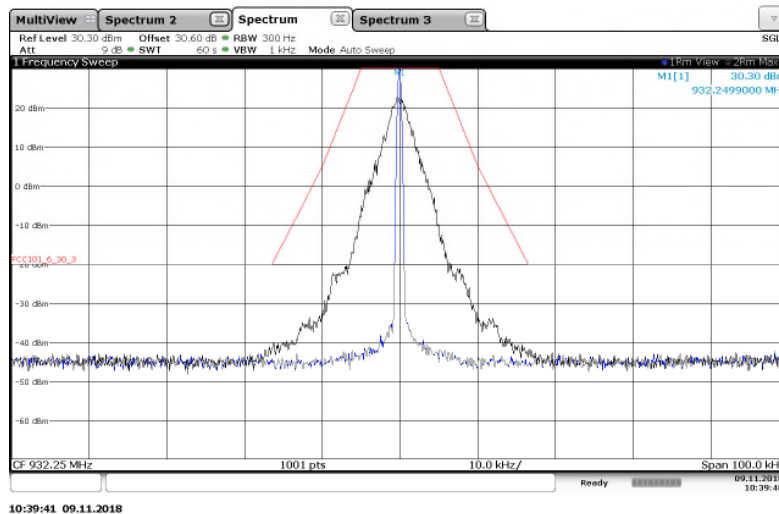

Figure 7.2.2-32: 932.25 MHz – 25 kHz Channel Spacing – Priority Mode

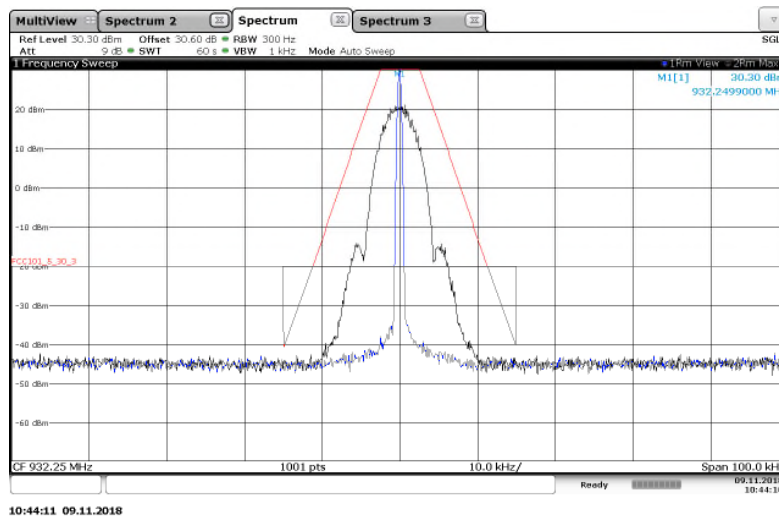

Figure 7.2.2-33: 932.25 MHz – 12.5 kHz Channel Spacing – 2SFSK (Half Baud) Mode

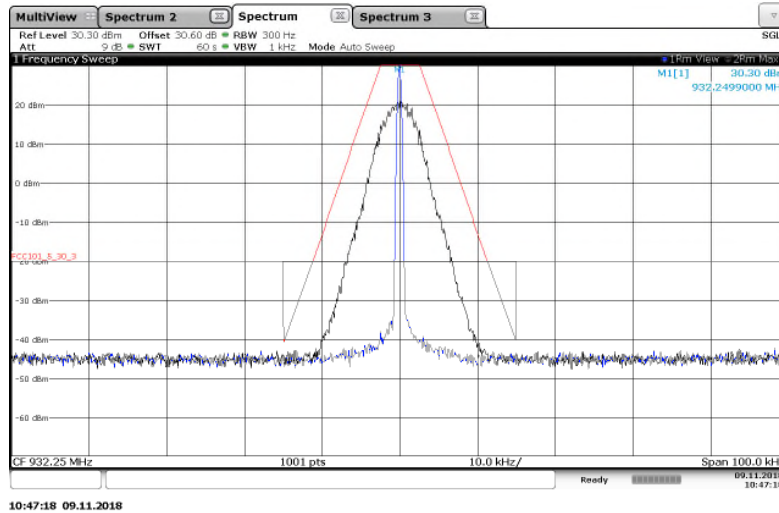

Figure 7.2.2-34: 932.25 MHz – 12.5 kHz Channel Spacing – 4FSK (Half Baud) Mode

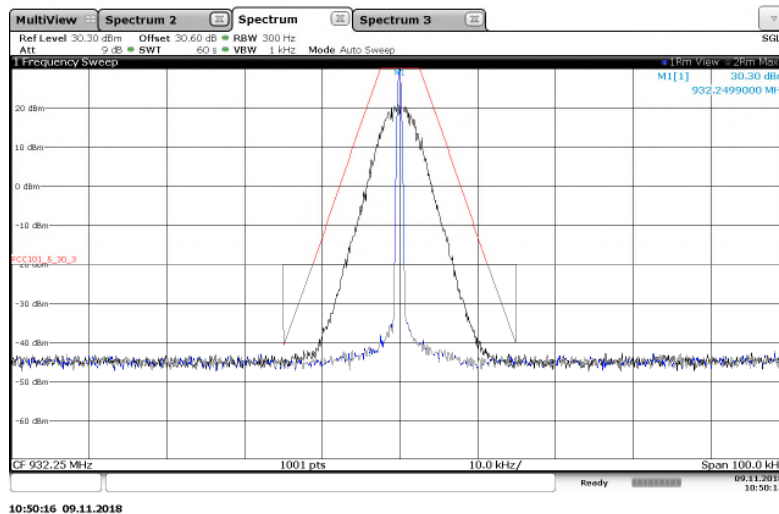

Figure 7.2.2-35: 932.25 MHz – 12.5 kHz Channel Spacing – 8FSK (Half Baud) Mode

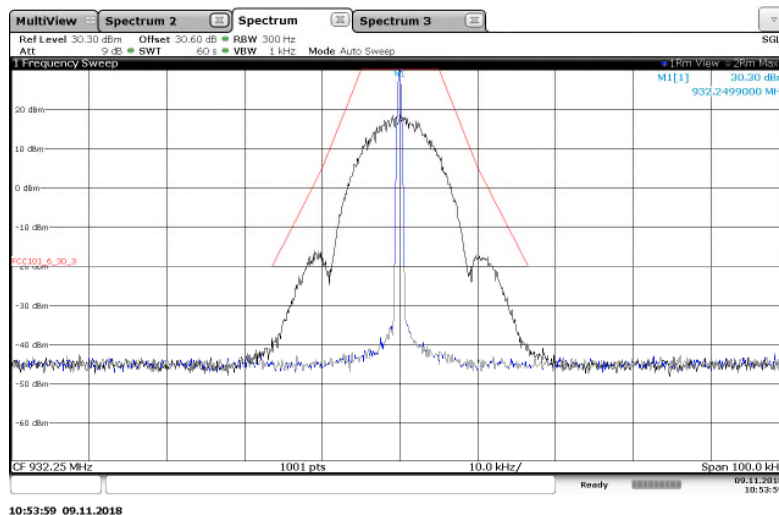

Figure 7.2.2-36: 932.25 MHz – 25 kHz Channel Spacing – 2FSK Mode

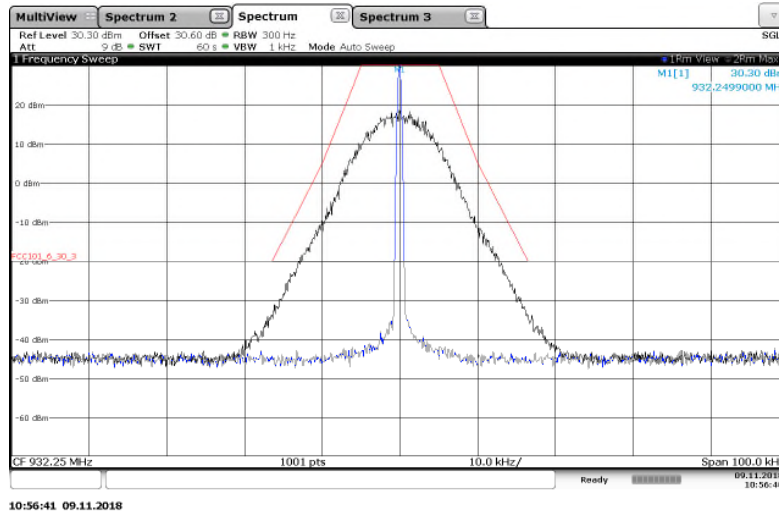

Figure 7.2.2-37: 932.25 MHz – 25 kHz Channel Spacing – 4FSK Mode

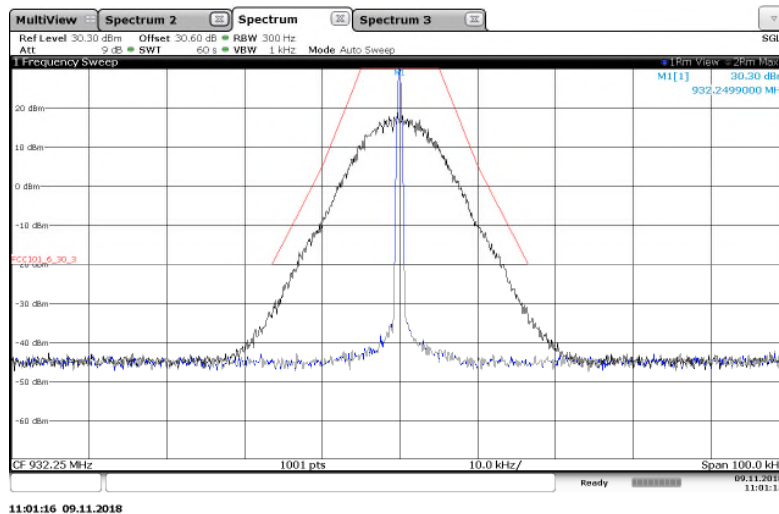

Figure 7.2.2-38: 932.25 MHz – 25 kHz Channel Spacing – 8FSK Mode

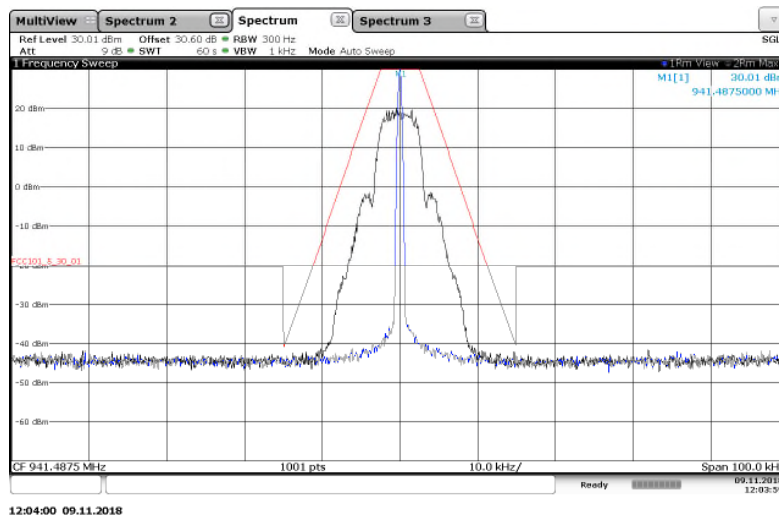

Figure 7.2.2-39: 941.4875 MHz – 12.5 kHz Channel Spacing – mPass 5k Mode

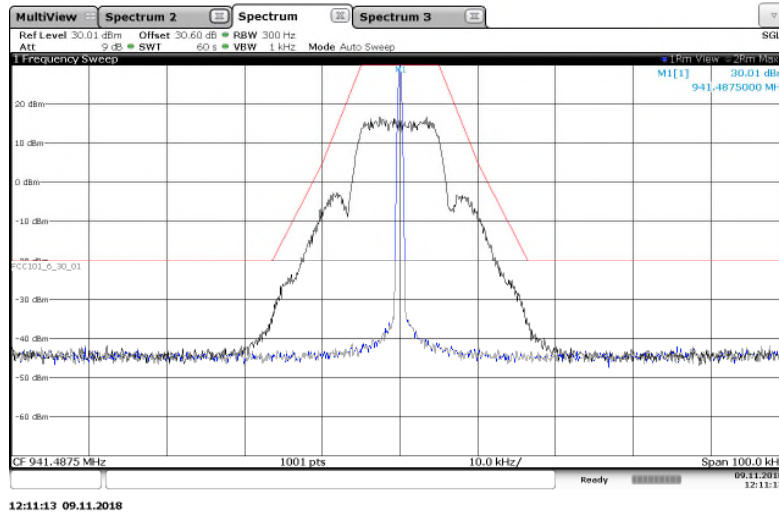

Figure 7.2.2-40: 941.4875 MHz – 25 kHz Channel Spacing – mPass 10k Mode

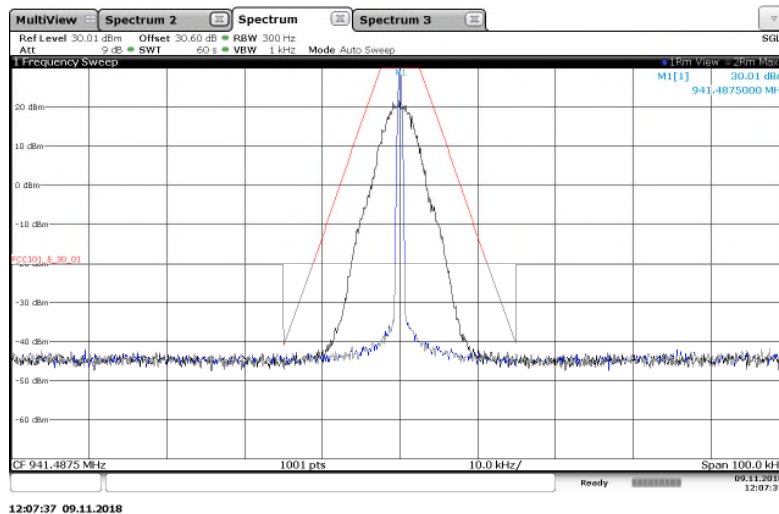

Figure 7.2.2-41: 941.4875 MHz – 12.5 kHz Channel Spacing – m4Pass 10k Mode

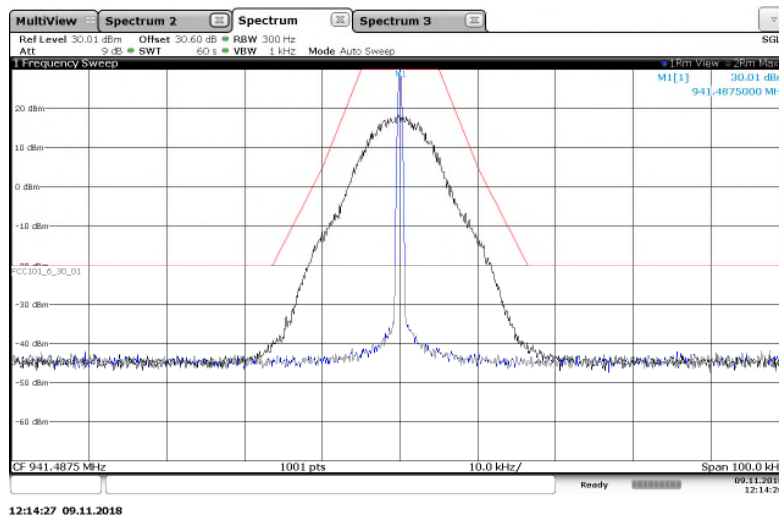

Figure 7.2.2-42: 941.4875 MHz – 25 kHz Channel Spacing – m4Pass 20k Mode

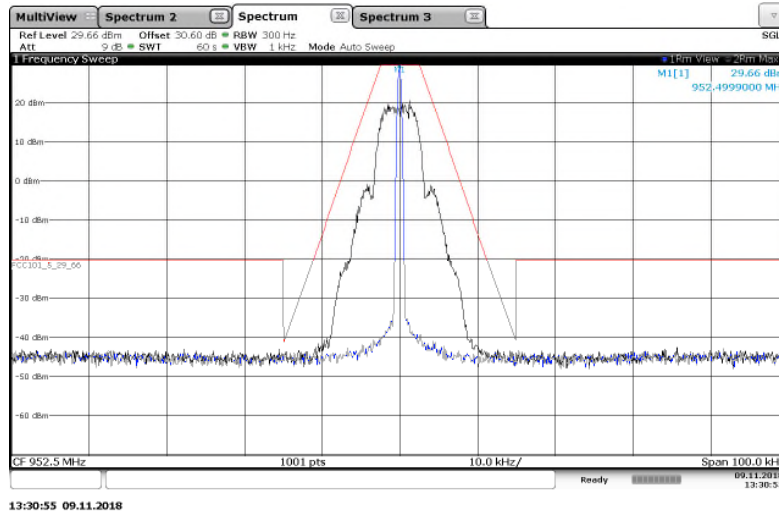

Figure 7.2.2-43: 952.5 MHz – 12.5 kHz Channel Spacing – mPass 5k Mode

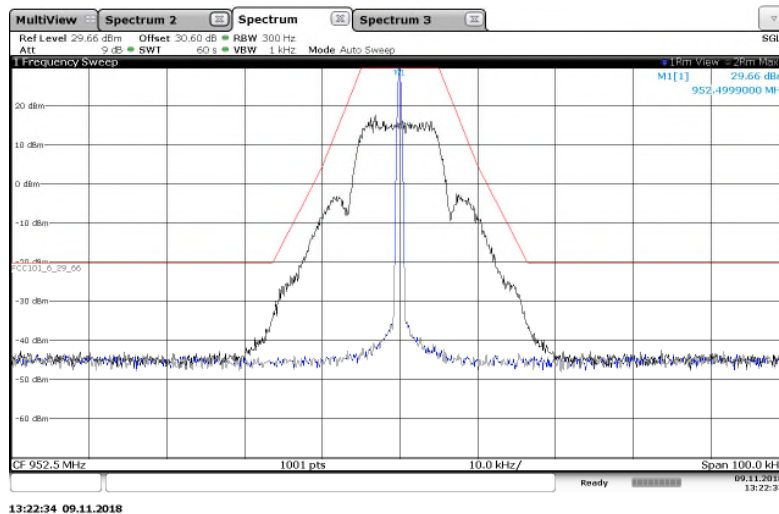

Figure 7.2.2-44: 952.5 MHz – 25 kHz Channel Spacing – mPass 10k Mode

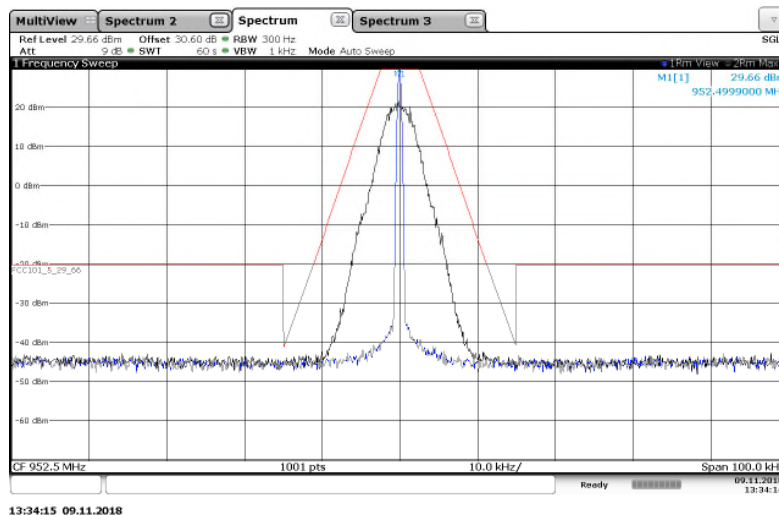

Figure 7.2.2-45: 952.5 MHz – 12.5 kHz Channel Spacing – m4Pass 10k Mode

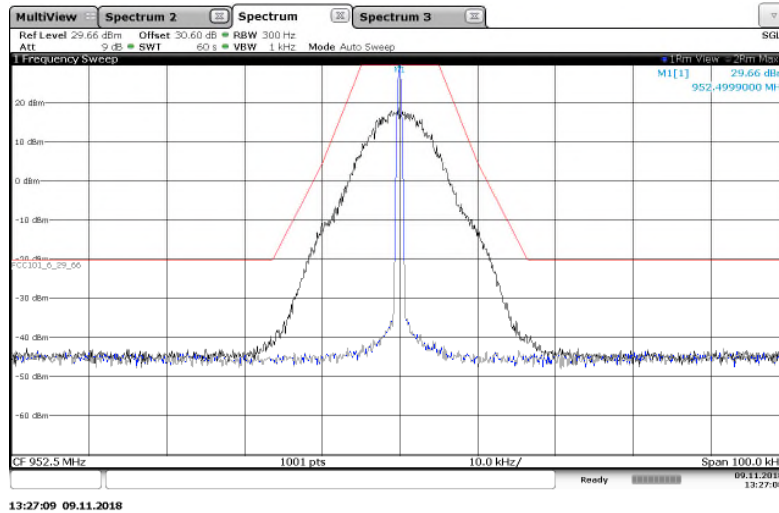

Figure 7.2.2-46: 952.5 MHz – 25 kHz Channel Spacing – m4Pass 20k Mode

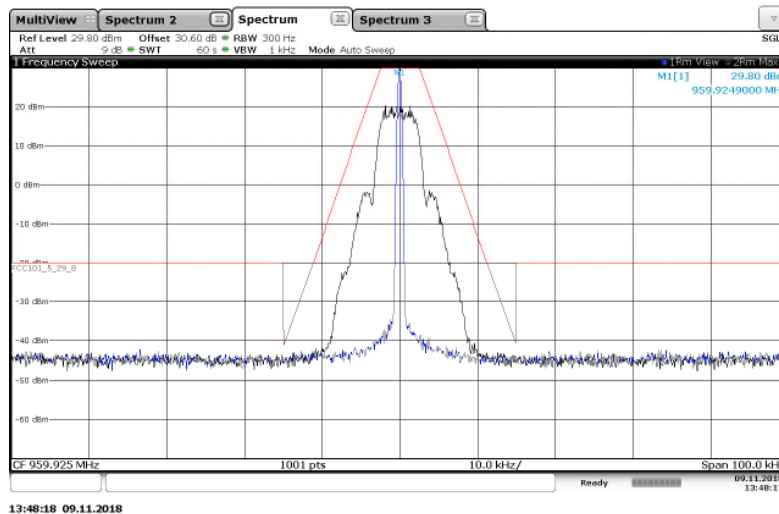

Figure 7.2.2-47: 959.925 MHz – 12.5 kHz Channel Spacing – mPass 5k Mode

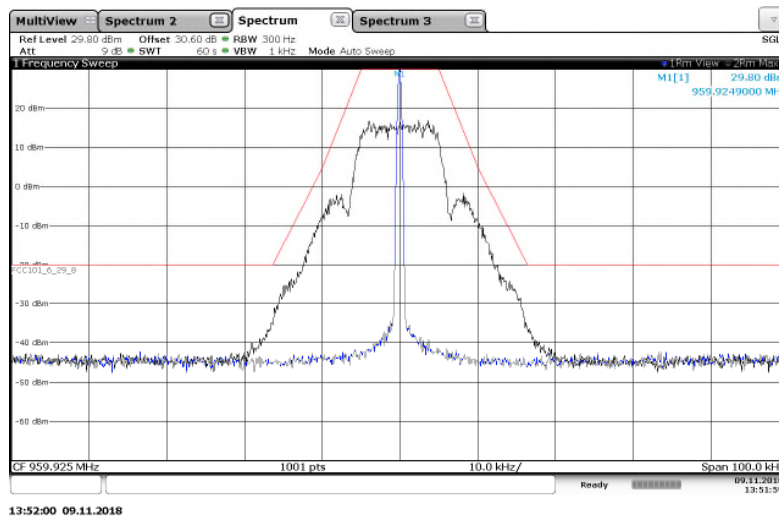

Figure 7.2.2-48: 959.925 MHz – 25 kHz Channel Spacing – mPass 10k Mode

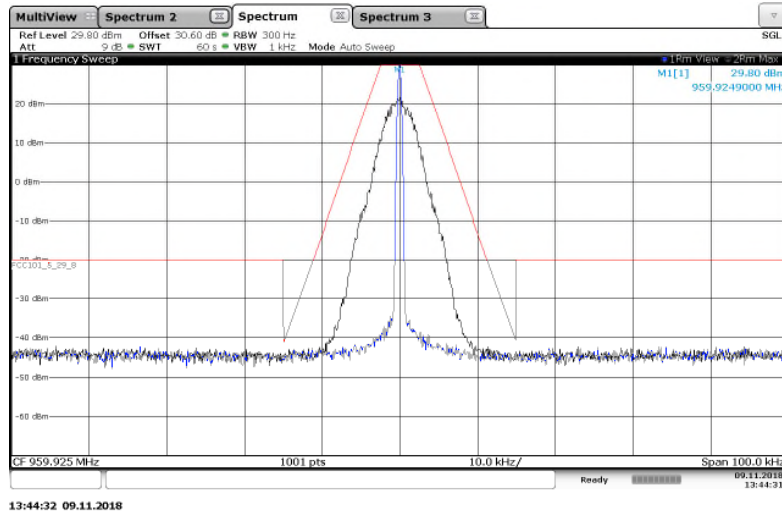

Figure 7.2.2-49: 959.925 MHz – 12.5 kHz Channel Spacing – m4Pass 10k Mode

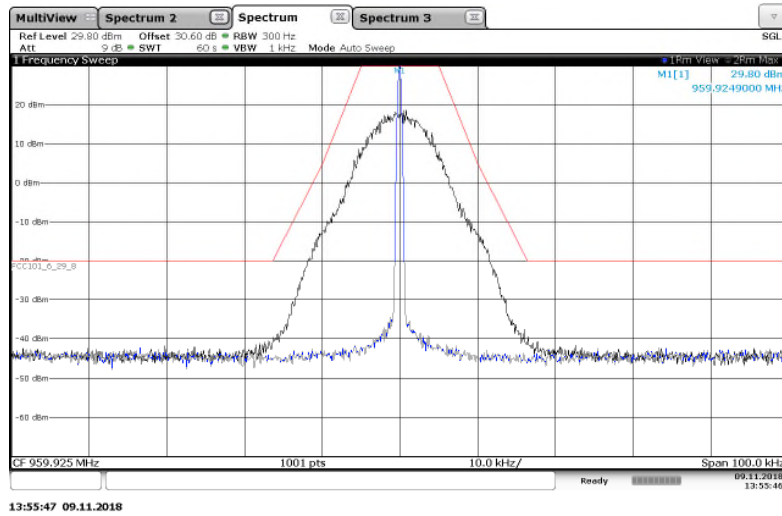

Figure 7.2.2-50: 959.925 MHz – 25 kHz Channel Spacing – m4Pass 20k Mode

7.3 99% Bandwidth

7.3.1 Measurement Procedure (ANSI 63.26: 2015 Section 5.4.4)

The RF output of the equipment under test was directly connected to the input of the Spectrum Analyzer through 30.6dB of passive attenuation. The internal correction factors of the spectrum analyzer were employed to correct for any cable and attenuator losses.

The spectrum analyzer center frequency is set to the nominal EUT channel center frequency. The frequency span for the spectrum analyzer shall be set wide enough to capture all modulation products including the emission skirts. The nominal IF filter 3 dB bandwidth (RBW) is in the range of 1% to 5% of the OBW, and the VBW was set $\geq 3 \times$ RBW. The reference level was set to prevent the signal amplitude from exceeding the maximum spectrum analyzer input mixer level for linear operation. The measurements were made using the spectrum analyzer's 99% BW function.

7.3.2 Measurement Results

Performed by: Ben Ford

Frequency (MHz)	ISED Canada Rule Part	Mode of Operation	99% Bandwidth (kHz)
901.5000	RSS-134	Normal	12.01
901.5000	RSS-134	Double Density	13.95
901.5000	RSS-134	C&I (Half-Baud)	6.00
901.5000	RSS-134	Priority	6.91
901.5000	RSS-134	2SFSK (Half Baud)	5.98
901.5000	RSS-134	4SFSK (Half Baud)	7.07
901.5000	RSS-134	8SFSK (Half Baud)	7.24
901.5000	RSS-134	2SFSK	11.97
901.5000	RSS-134	4SFSK	14.01
901.5000	RSS-134	8SFSK	14.88
930.5000	RSS-134	MPass 5k	5.81
930.5000	RSS-134	MPass 10k	11.78
930.5000	RSS-134	M4Pass 10k	6.00
930.5000	RSS-134	M4Pass 20k	12.24
940.0125	RSS-134	MPass 5k	5.82
940.0125	RSS-134	MPass 10k	11.77
940.0125	RSS-134	M4Pass 10k	6.04
940.0125	RSS-134	M4Pass 20k	12.25
928.9250	RSS-119	Normal	12.00
928.9250	RSS-119	Double Density	14.14
928.9250	RSS-119	C&I (Half-Baud)	6.06
928.9250	RSS-119	Priority	7.10
928.9250	RSS-119	2SFSK (Half Baud)	6.01
928.9250	RSS-119	4SFSK (Half Baud)	6.85
928.9250	RSS-119	8SFSK (Half Baud)	7.35
928.9250	RSS-119	2SFSK	11.94
928.9250	RSS-119	4SFSK	14.03

Frequency (MHz)	ISED Canada Rule Part	Mode of Operation	99% Bandwidth (kHz)
928.9250	RSS-119	8SFSK	14.80
932.2500	RSS-119	Normal	12.00
932.2500	RSS-119	Double Density	14.23
932.2500	RSS-119	C&I (Half-Baud)	6.18
932.2500	RSS-119	Priority	6.91
932.2500	RSS-119	2SFSK (Half Baud)	5.95
932.2500	RSS-119	4SFSK (Half Baud)	6.96
932.2500	RSS-119	8SFSK (Half Baud)	7.22
932.2500	RSS-119	2SFSK	11.95
932.2500	RSS-119	4SFSK	14.07
932.2500	RSS-119	8SFSK	14.78
941.4875	RSS-119	MPass 5k	5.83
941.4875	RSS-119	MPass 10k	11.78
941.4875	RSS-119	M4Pass 10k	6.13
941.4875	RSS-119	M4Pass 20k	12.10
952.5000	RSS-119	MPass 5k	5.82
952.5000	RSS-119	MPass 10k	11.78
952.5000	RSS-119	M4Pass 10k	6.04
952.5000	RSS-119	M4Pass 20k	12.14
959.9250	RSS-119	MPass 5k	5.78
959.9250	RSS-119	MPass 10k	11.79
959.9250	RSS-119	M4Pass 10k	6.04
959.9250	RSS-119	M4Pass 20k	12.05

ISED Canada RSS-GEN 6.6, ISED Canada RSS-134

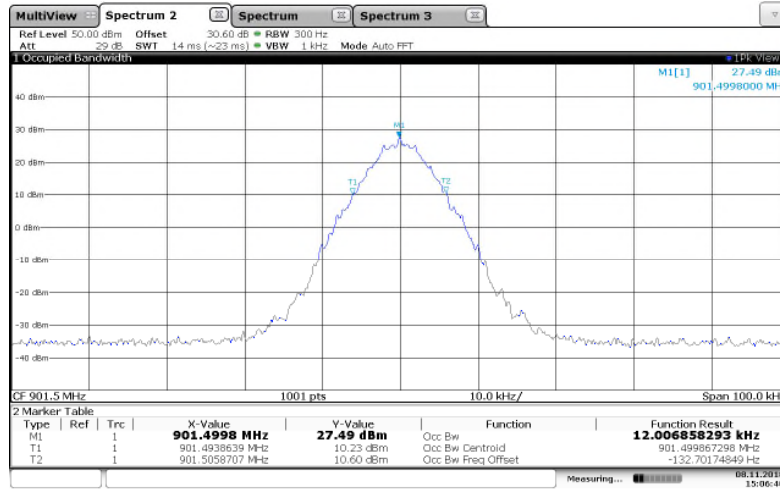

15:06:40 08.11.2018

Figure 7.3.2-1: 901.5 MHz – Normal Mode

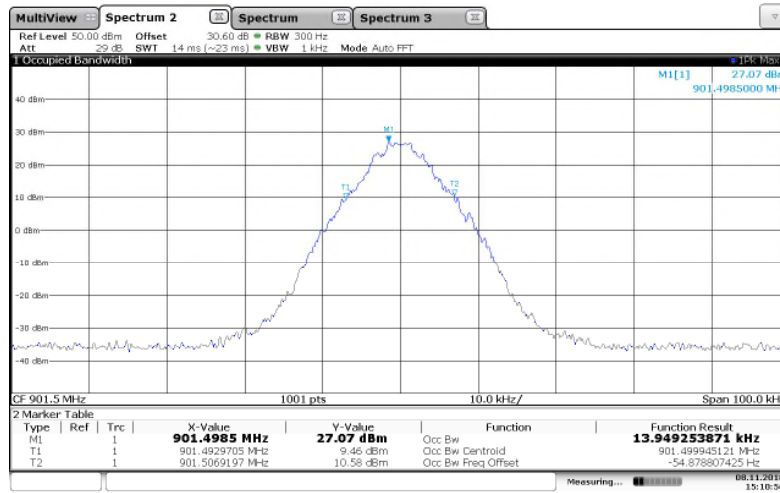

15:10:57 08.11.2018

Figure 7.3.2-2: 901.5 MHz – Double Density Mode

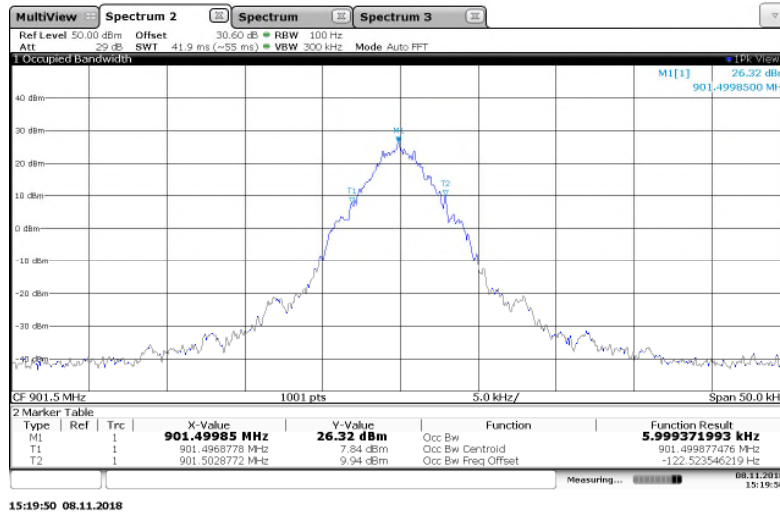

Figure 7.3.2-3: 901.5 MHz – C&I (Half Baud) Mode

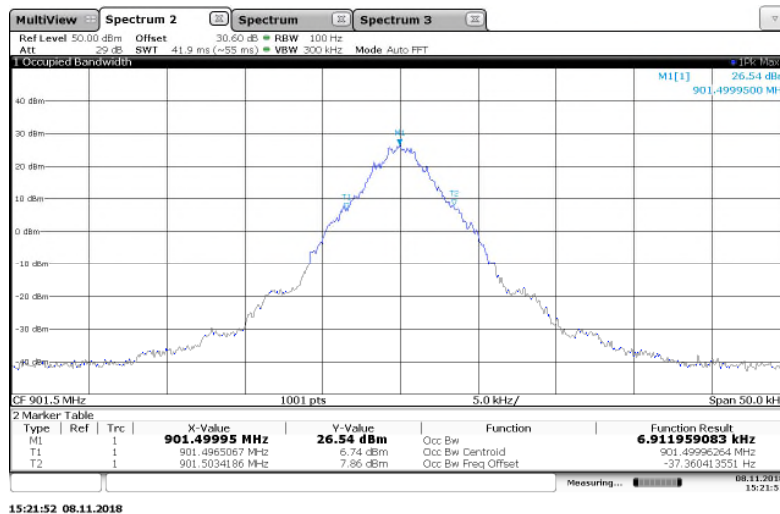

Figure 7.3.2-4: 901.5 MHz – Priority Mode

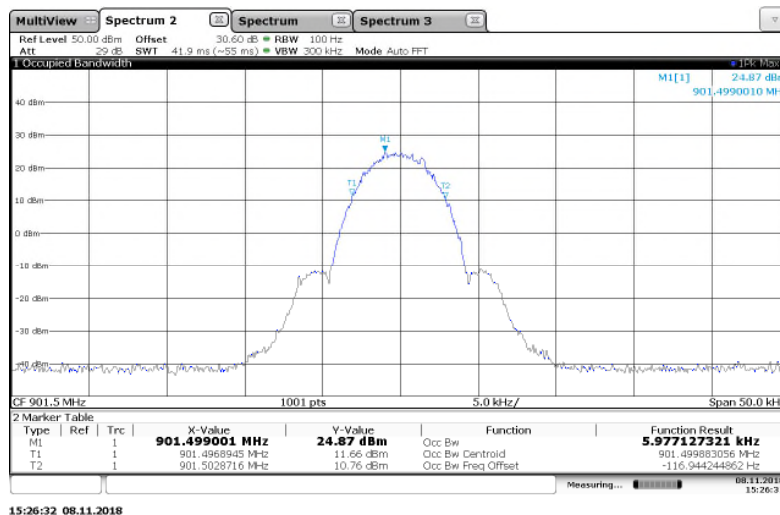

Figure 7.3.2-5: 901.5 MHz – 2SFSK (Half Baud) Mode

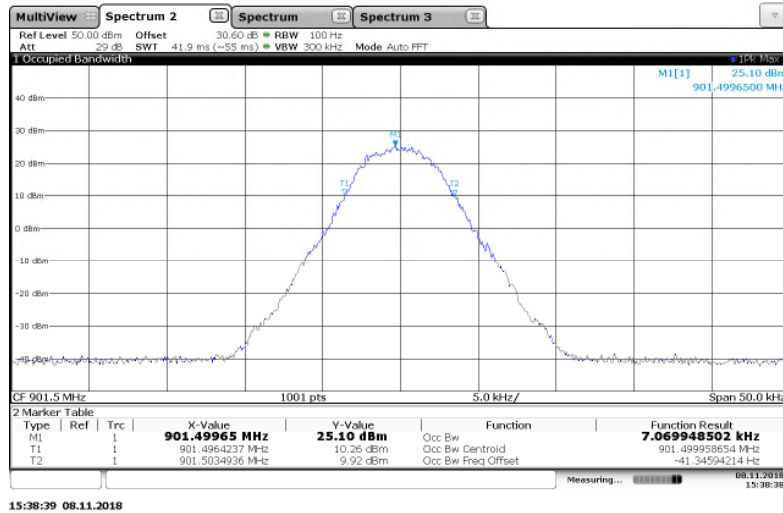

Figure 7.3.2-6: 901.5 MHz – 4FSK (Half Baud) Mode

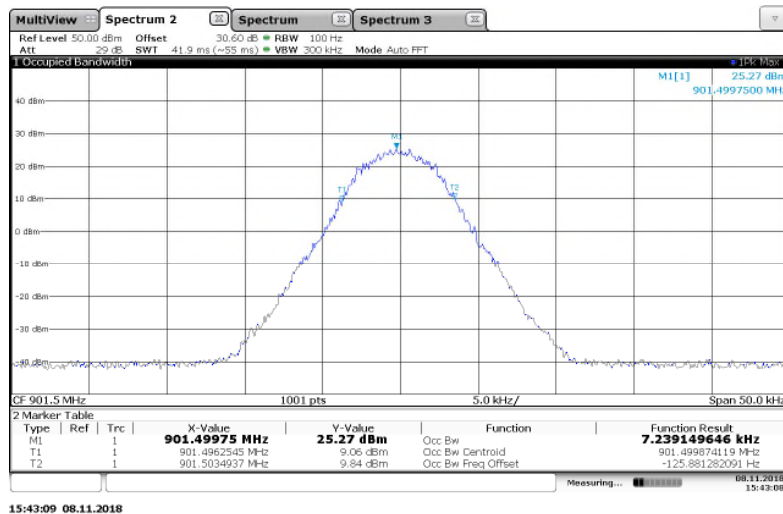

Figure 7.3.2-7: 901.5 MHz – 8FSK (Half Baud) Mode

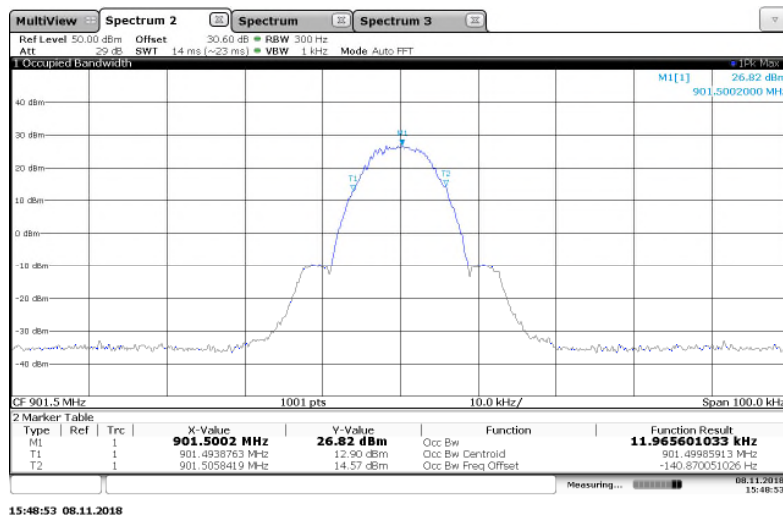

Figure 7.3.2-8: 901.5 MHz – 2FSK Mode

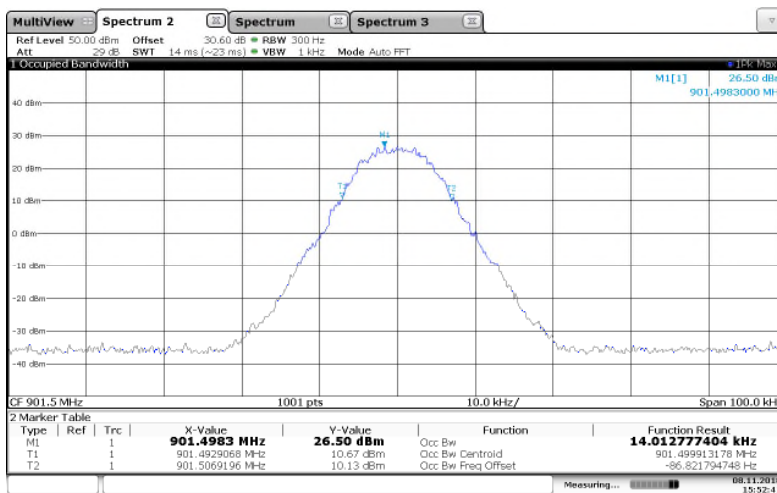

Figure 7.3.2-9: 901.5 MHz – 4SFSK Mode

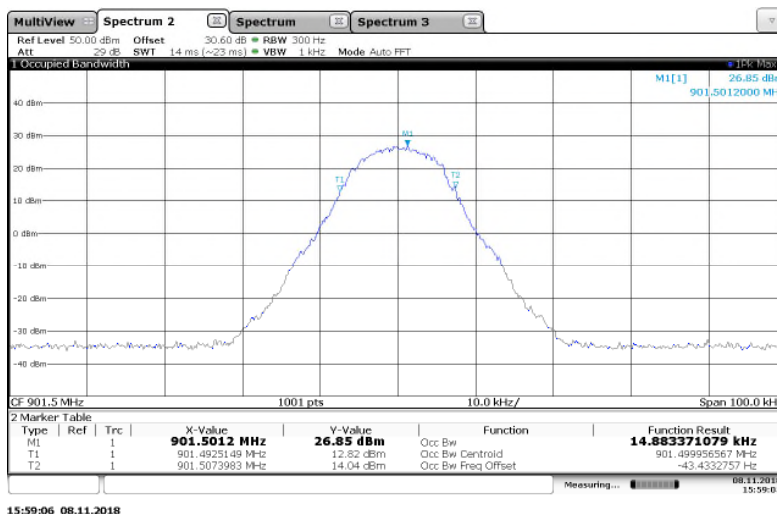

Figure 7.3.2-10: 901.5 MHz – 8SFSK Mode

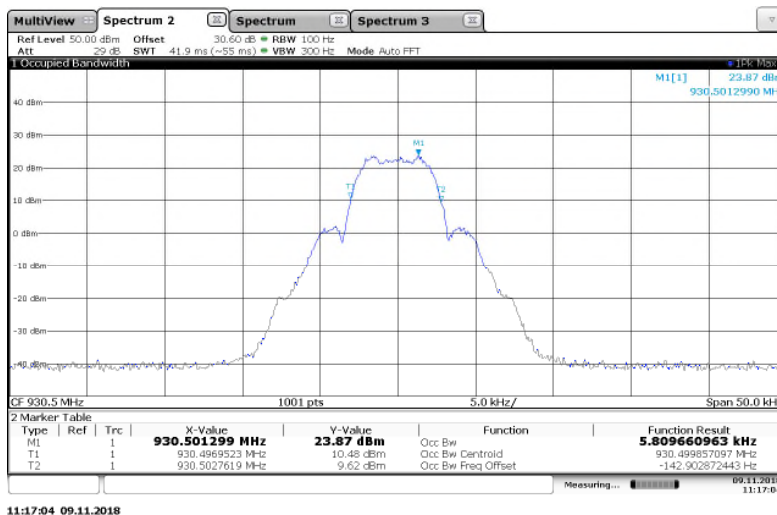

Figure 7.3.2-11: 930.5 MHz – MPass 5k Mode

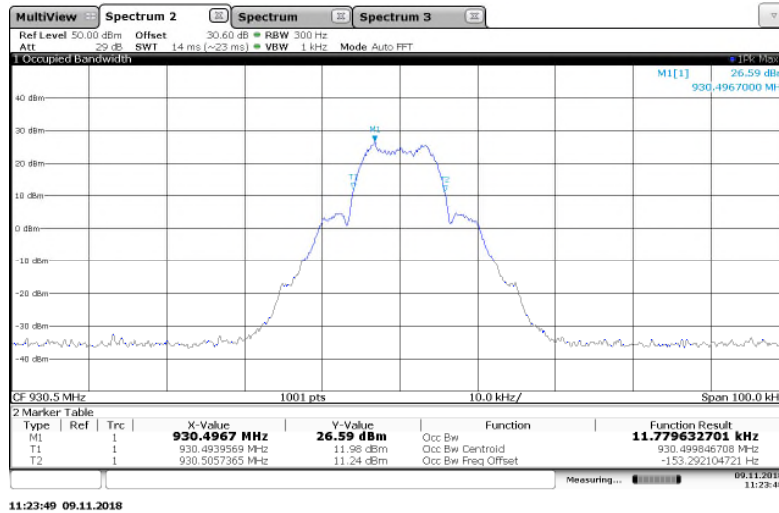

Figure 7.3.2-12: 930.5 MHz – MPass 10k Mode

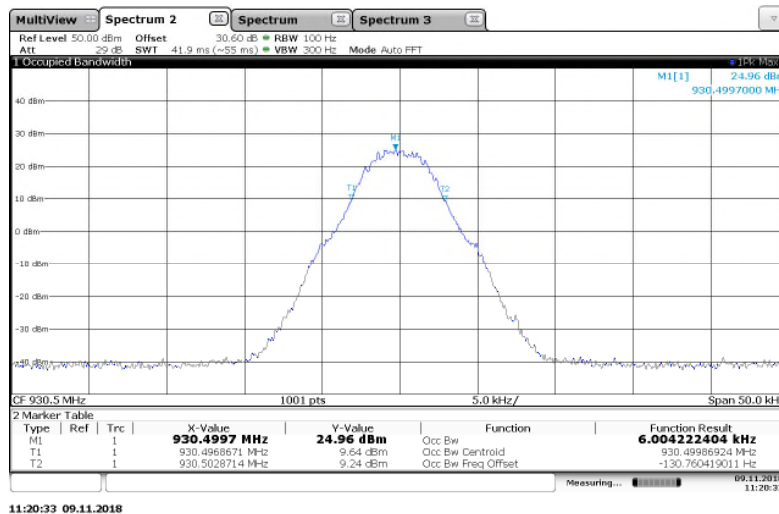

Figure 7.3.2-13: 930.5 MHz – M4Pass 10k Mode

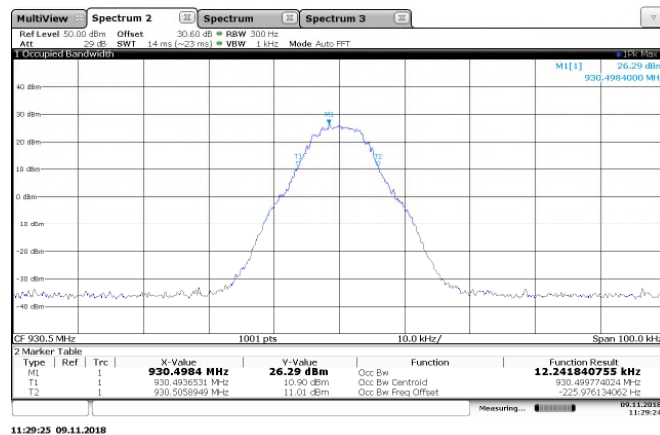

Figure 7.3.2-14: 930.5 MHz – M4Pass 20k Mode

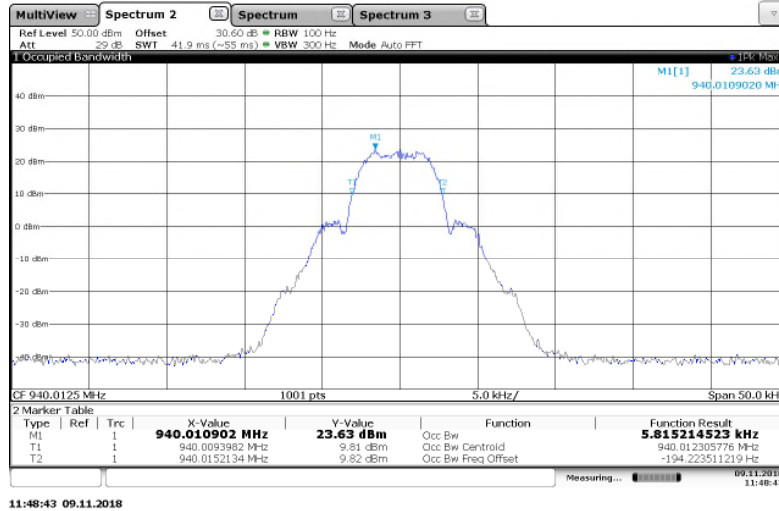

Figure 7.3.2-15: 940.0125 MHz – MPass 5k Mode

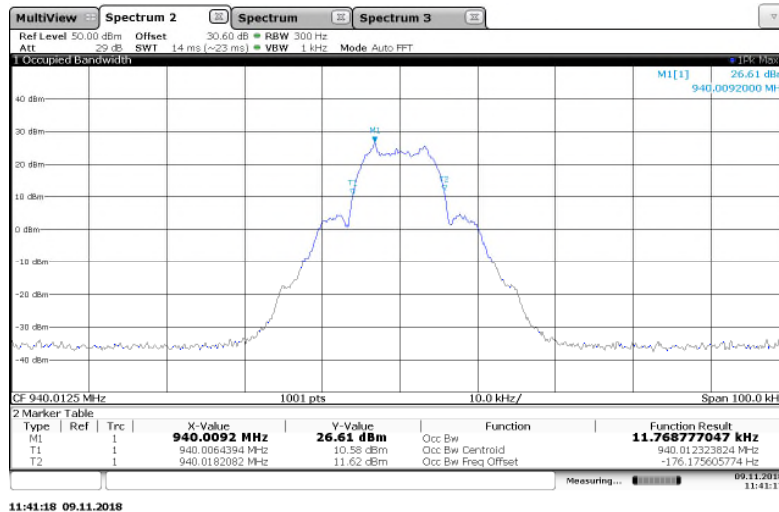

Figure 7.3.2-16: 940.0125 MHz – MPass 10k Mode

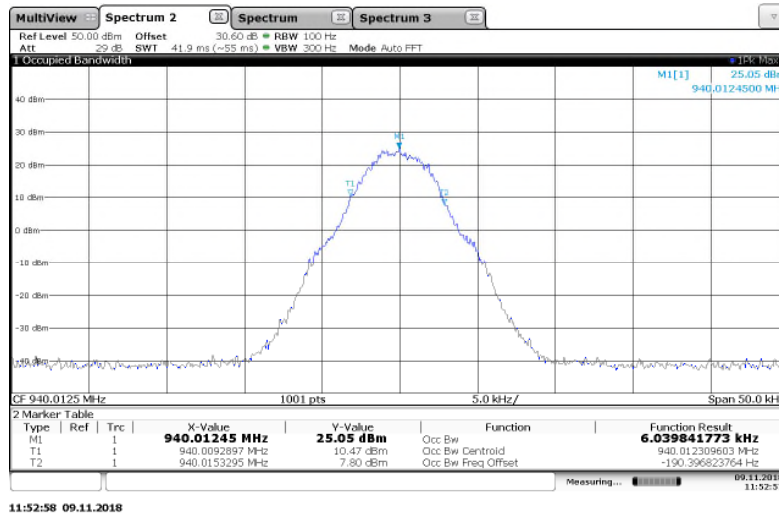

Figure 7.3.2-17: 940.0125 MHz – M4Pass 10k Mode

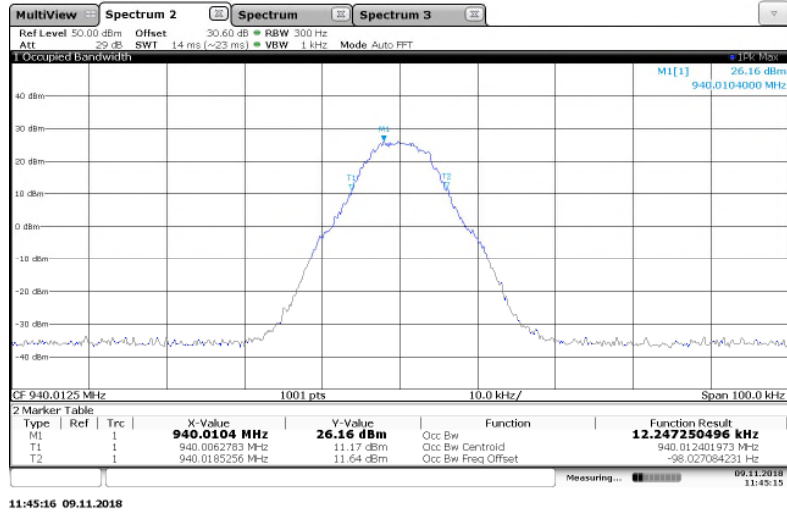

Figure 7.3.2-18: 940.0125 MHz – M4Pass 20k Mode

ISED Canada RSS-GEN 6.6, ISED Canada RSS-119

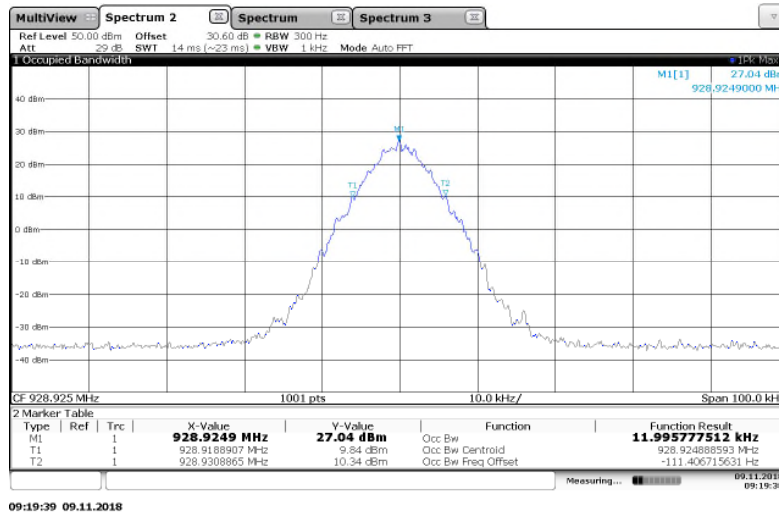

Figure 7.3.2-19: 928.925 MHz – Normal Mode

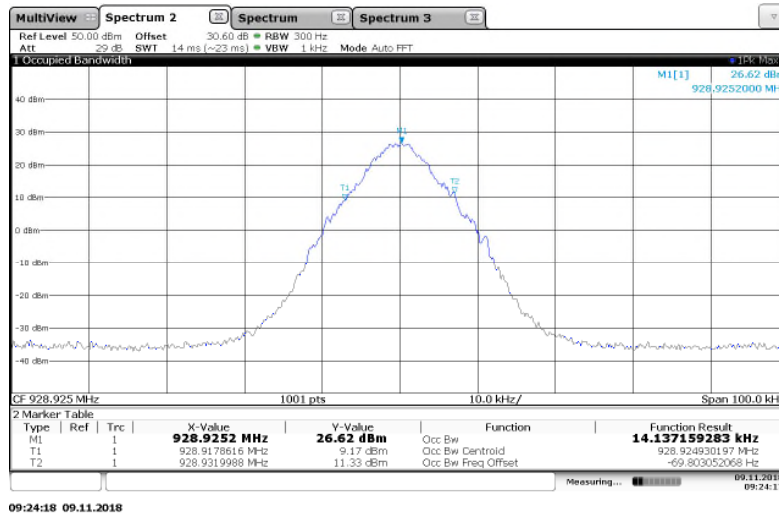

Figure 7.3.2-20: 928.925 MHz – Double Density Mode

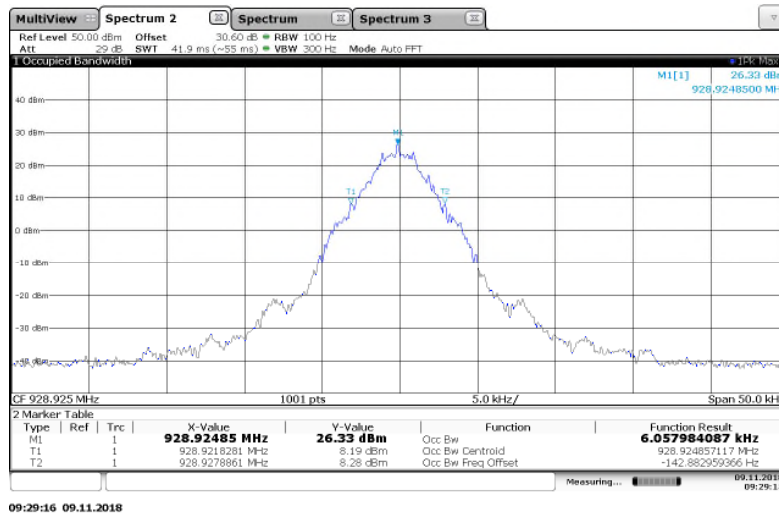
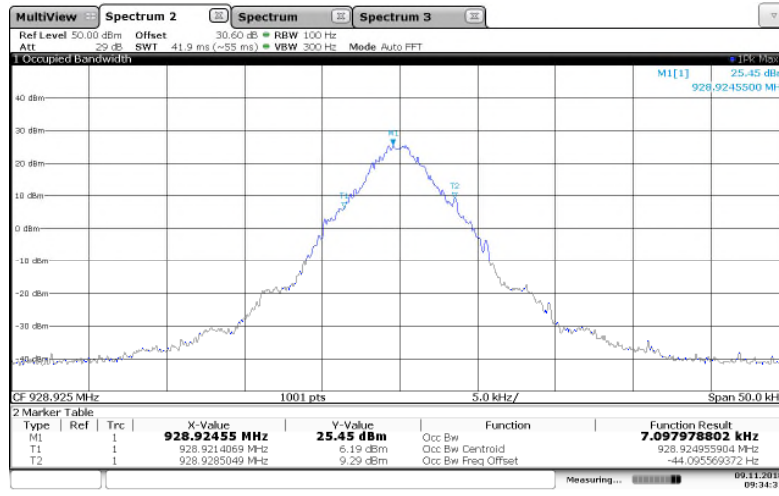
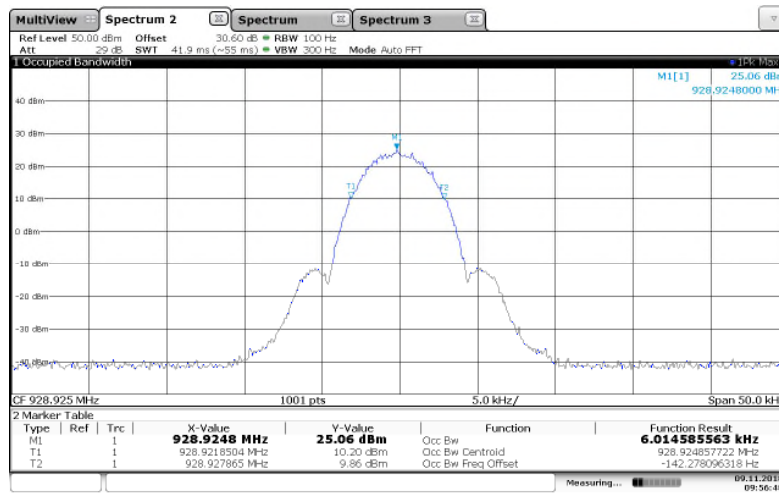

Figure 7.3.2-21: 928.925 MHz – C&I (Half Baud) Mode



09:34:31 09.11.2018

Figure 7.3.2-22: 928.925 MHz – Priority Mode



09:56:49 09.11.2018

Figure 7.3.2-23: 928.925 MHz – 2FSK (Half Baud) Mode

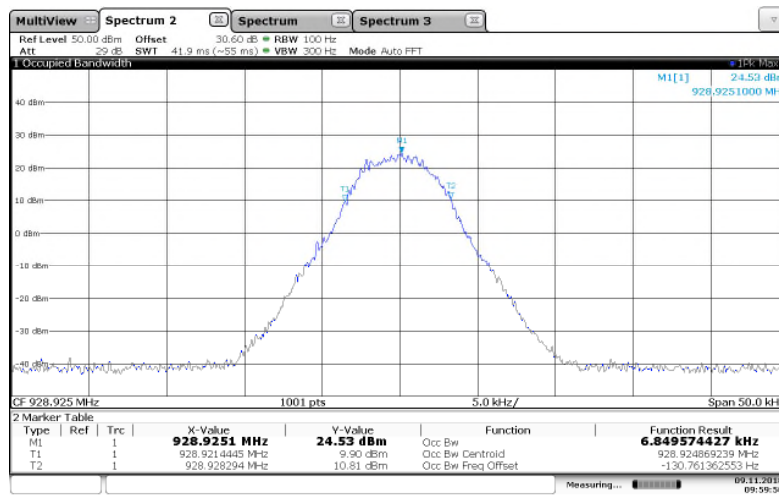

09:59:50 09.11.2018

Figure 7.3.2-24: 928.925 MHz – 4FSK (Half Baud) Mode

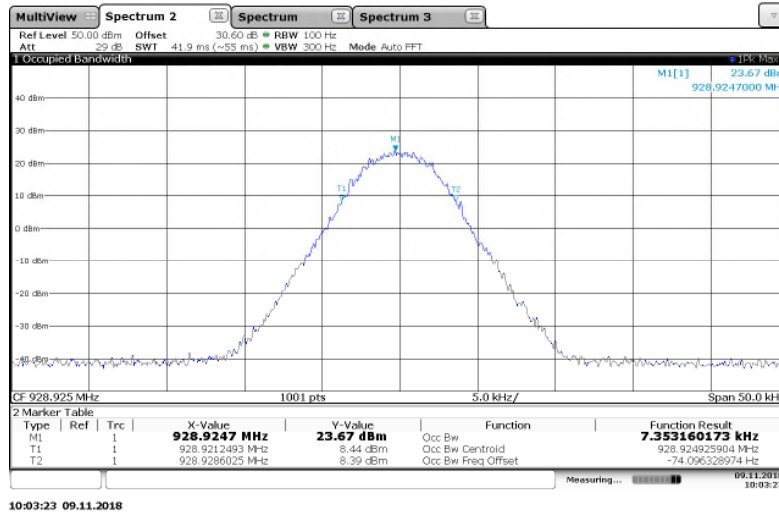

Figure 7.3.2-25: 928.925 MHz – 8FSK (Half Baud) Mode

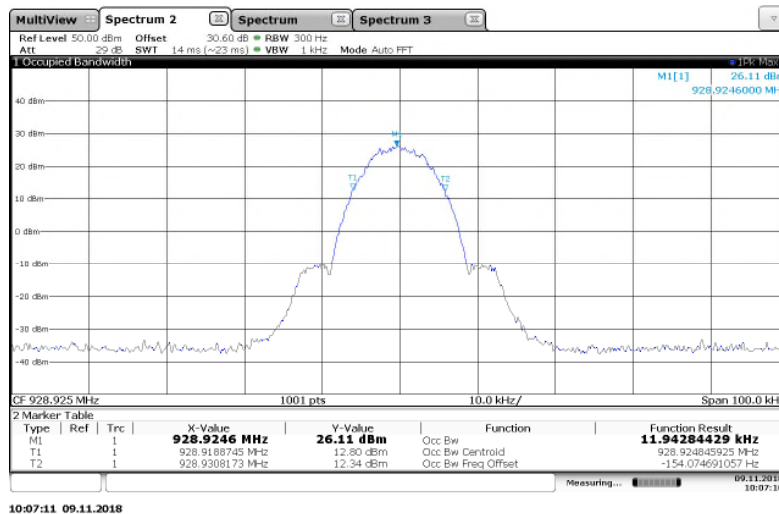

Figure 7.3.2-26: 928.925 MHz – 2SFSK Mode

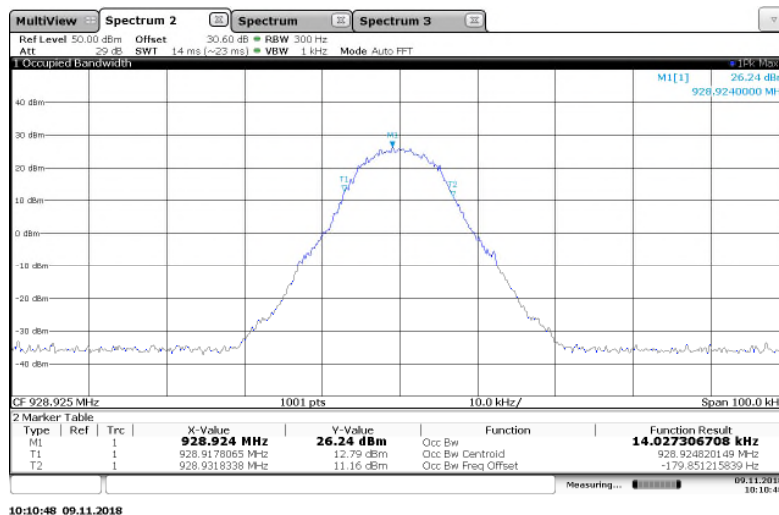

Figure 7.3.2-27: 928.925 MHz – 4SFSK Mode

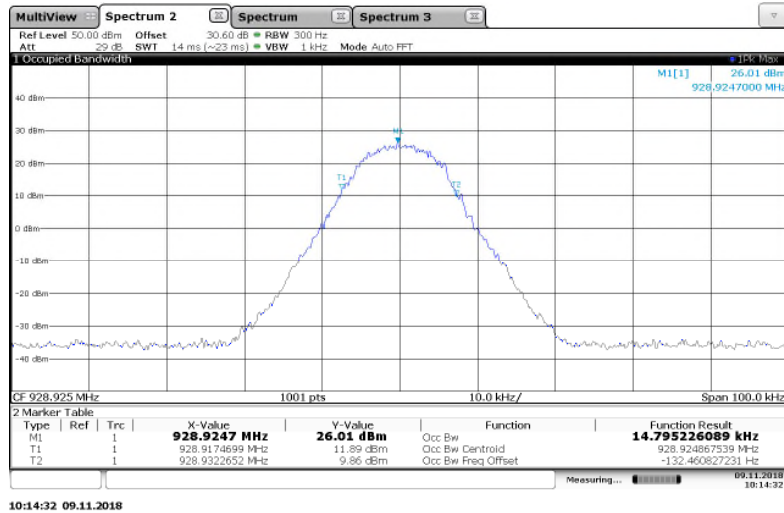

Figure 7.3.2-28: 928.925 MHz – 8FSK Mode

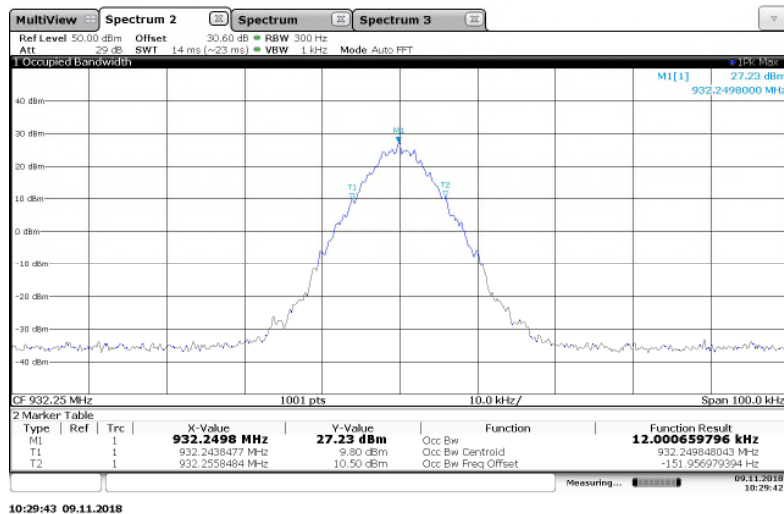

Figure 7.3.2-29: 932.25 MHz – Normal Mode

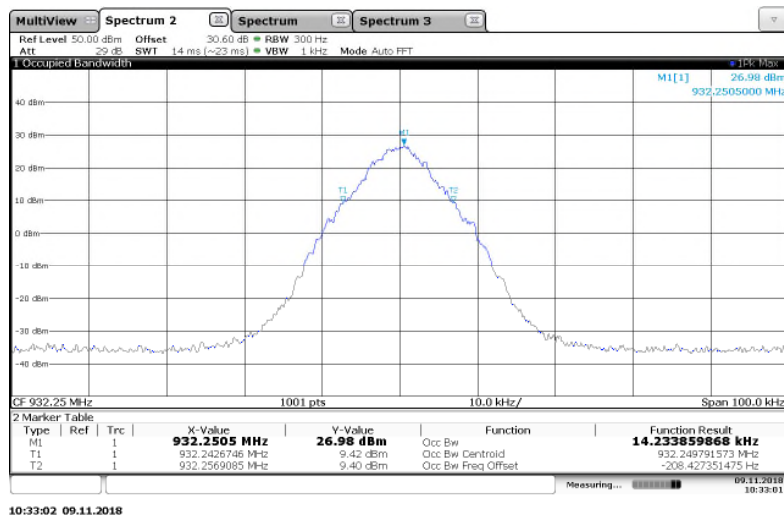

Figure 7.3.2-30: 932.25 MHz – Double Density Mode

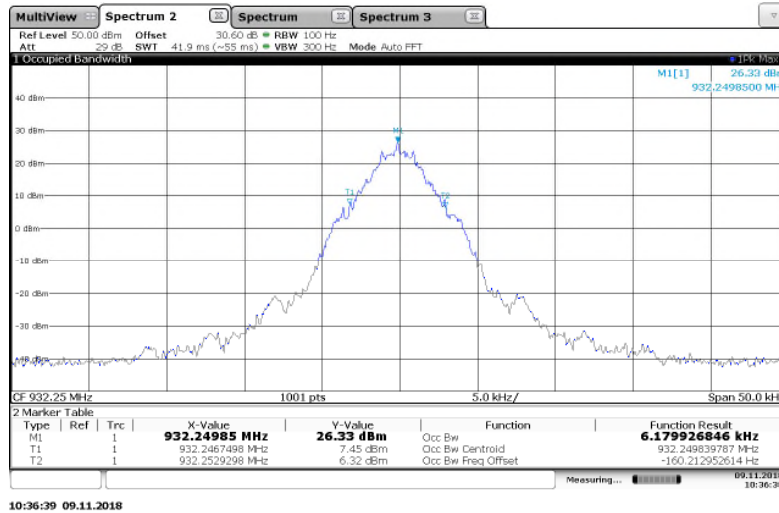

Figure 7.3.2-31: 932.25 MHz – C&I (Half Baud) Mode

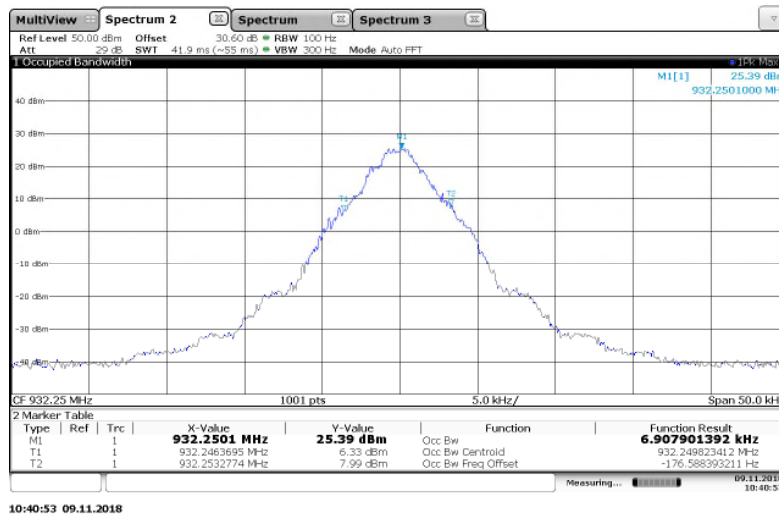

Figure 7.3.2-32: 932.25 MHz – Priority Mode

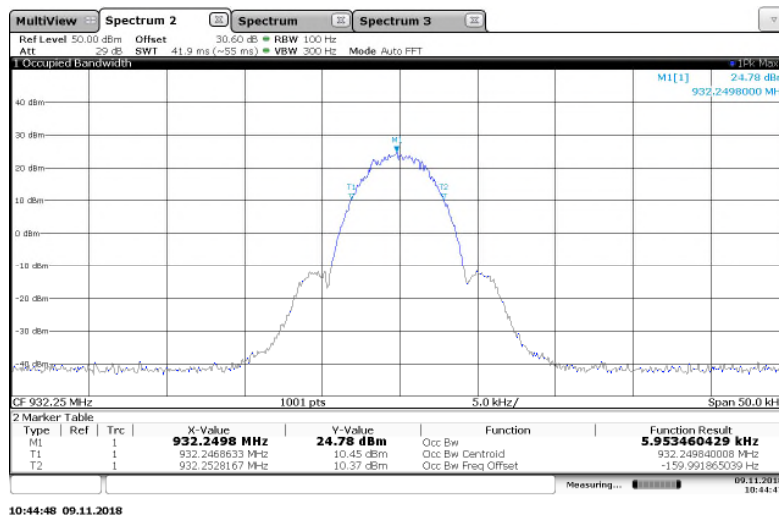

Figure 7.3.2-33: 932.25 MHz – 2SFSK (Half Baud) Mode

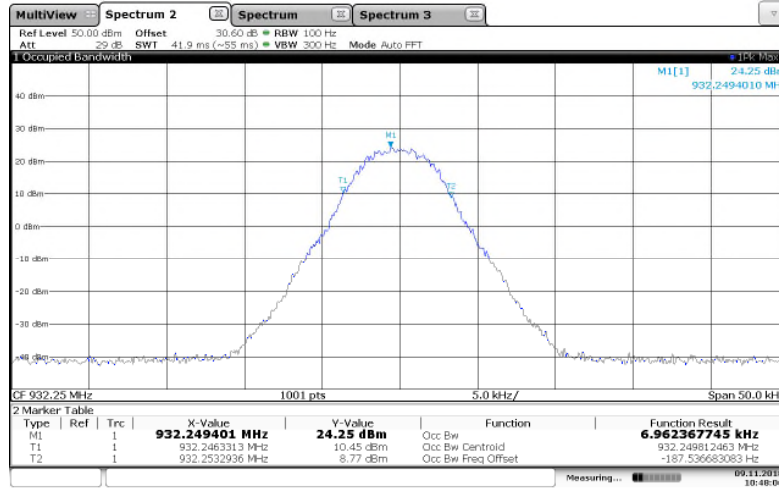

Figure 7.3.2-34: 932.25 MHz – 4FSK (Half Baud) Mode

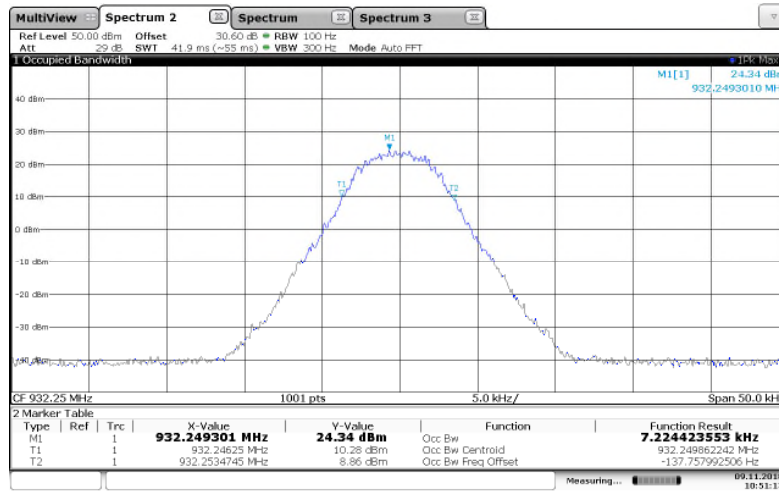

Figure 7.3.2-35: 932.25 MHz – 8FSK (Half Baud) Mode

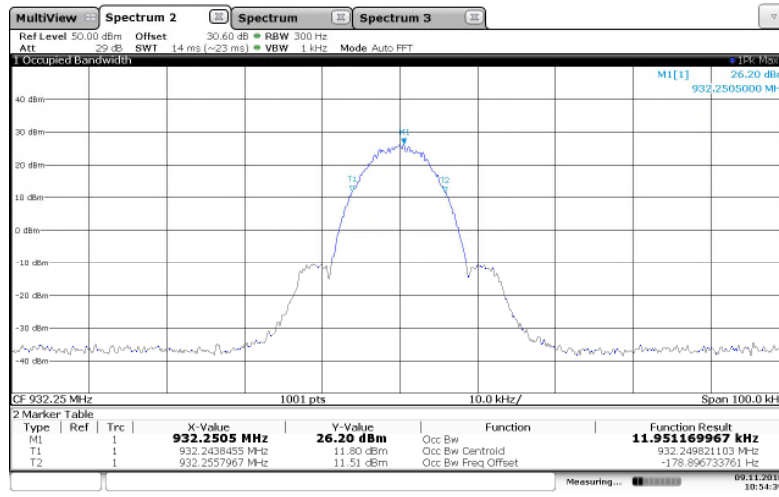

Figure 7.3.2-36: 932.25 MHz – 2FSK Mode

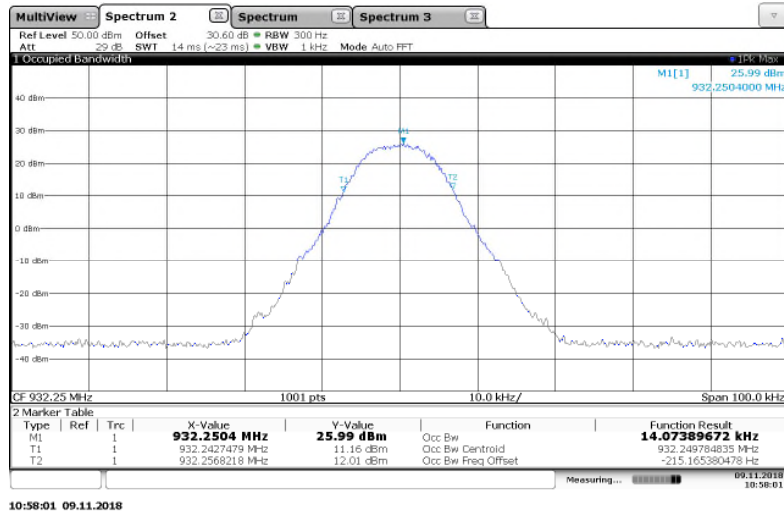

Figure 7.3.2-37: 932.25 MHz – 4FSK Mode

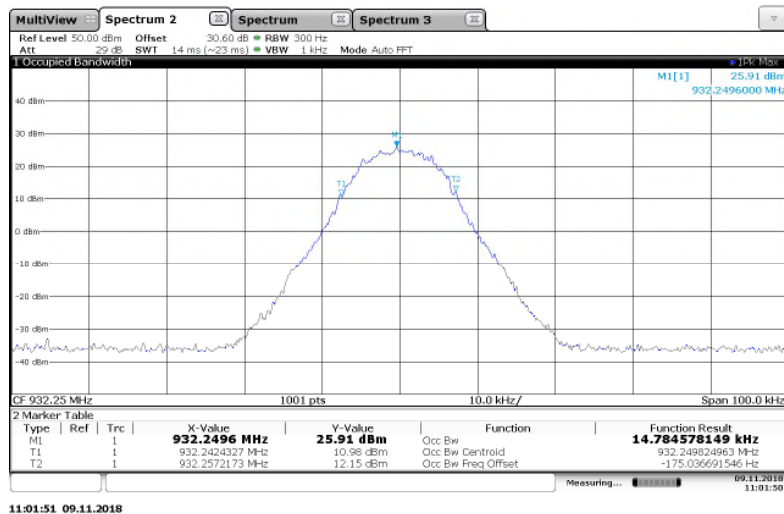

Figure 7.3.2-38: 932.25 MHz – 8FSK Mode

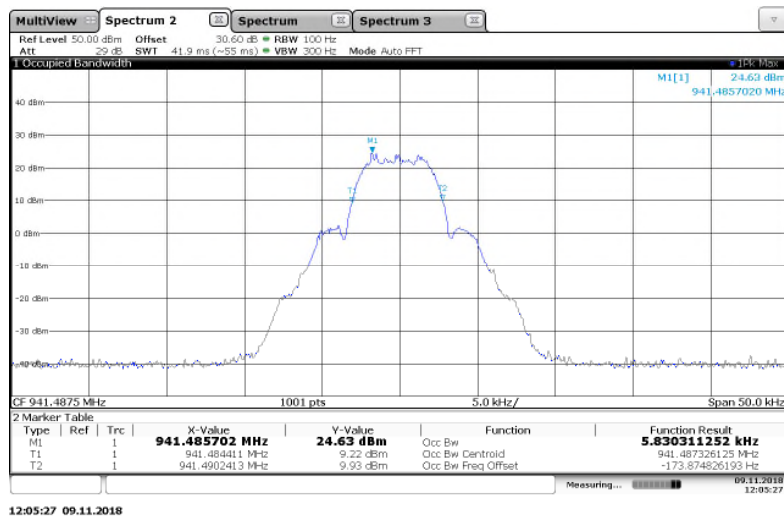

Figure 7.3.2-39: 941.4875 MHz – MPass 5k Mode

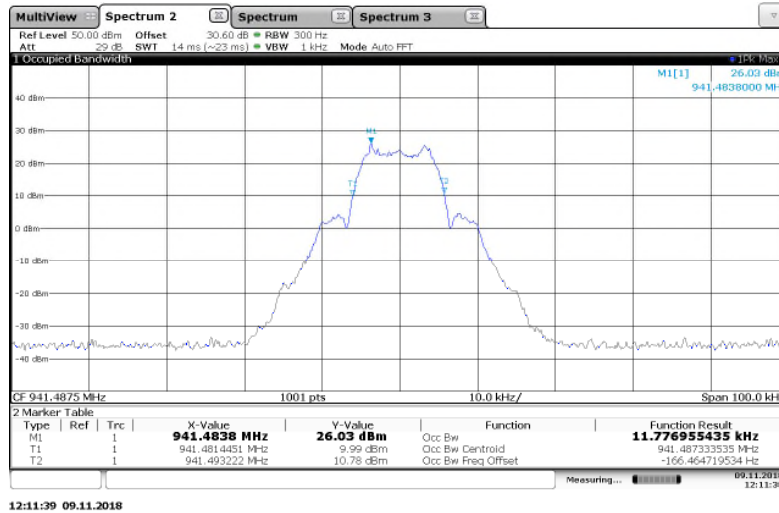

Figure 7.3.2-40: 941.4875 MHz – MPass 10k Mode

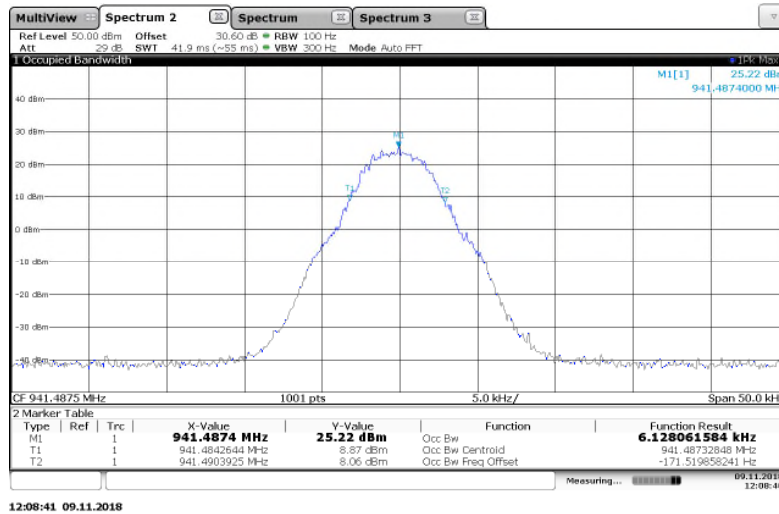

Figure 7.3.2-41: 941.4875 MHz – M4Pass 10k Mode

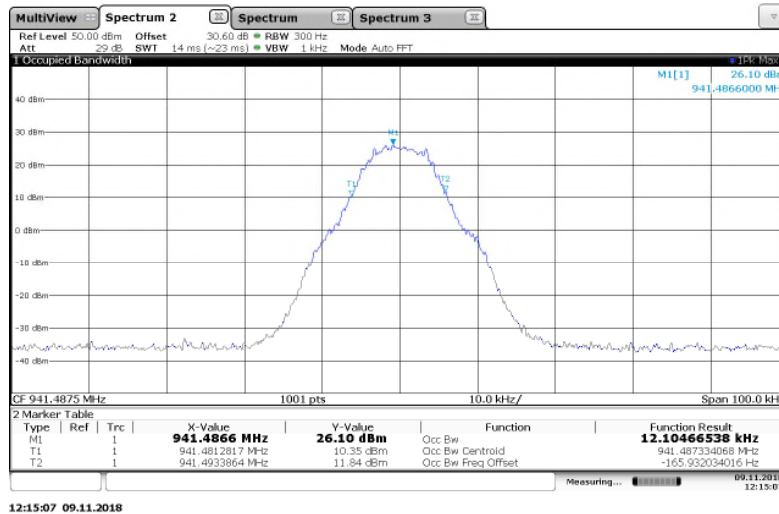

Figure 7.3.2-42: 941.4875 MHz – M4Pass 20k Mode

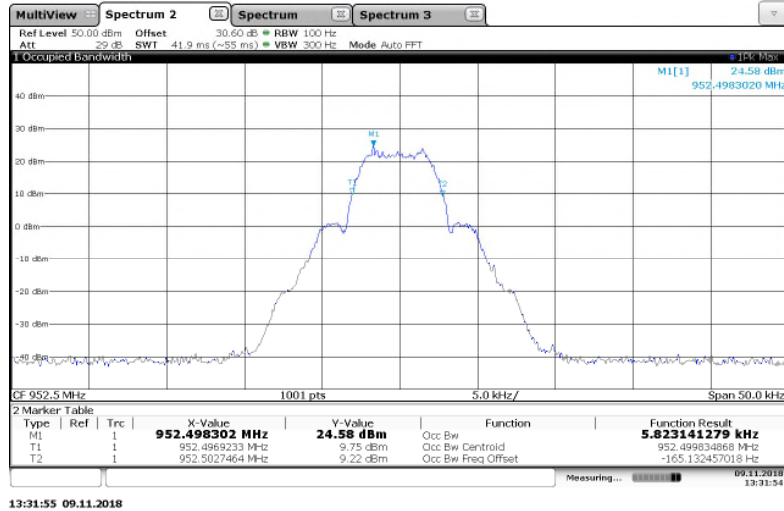

Figure 7.3.2-43: 952.5 MHz – MPass 5k Mode

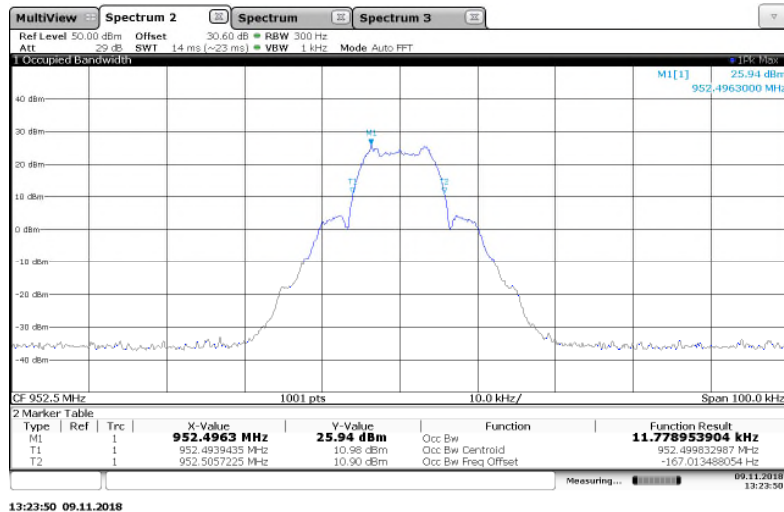

Figure 7.3.2-44: 952.5 MHz – MPass 10k Mode

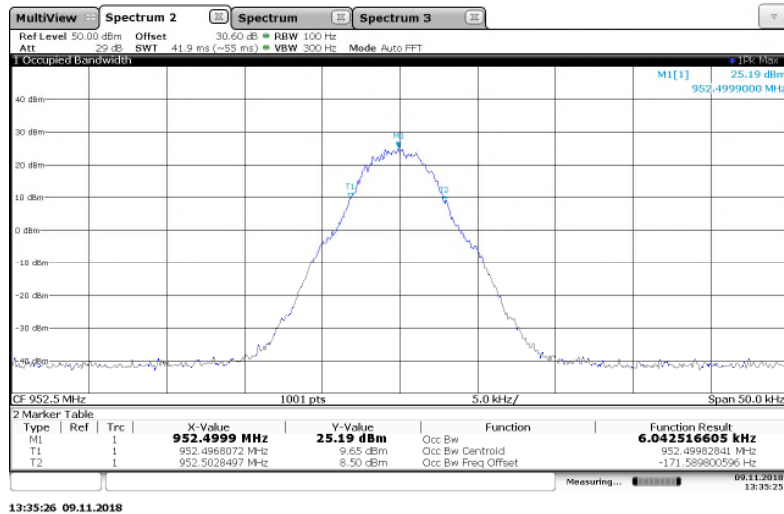

Figure 7.3.2-45: 952.5 MHz – M4Pass 10k Mode

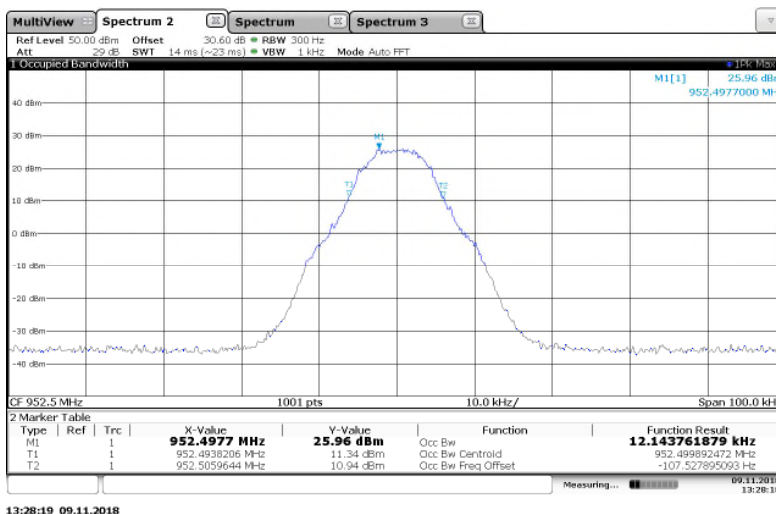

Figure 7.3.2-46: 952.5 MHz – M4Pass 20k Mode

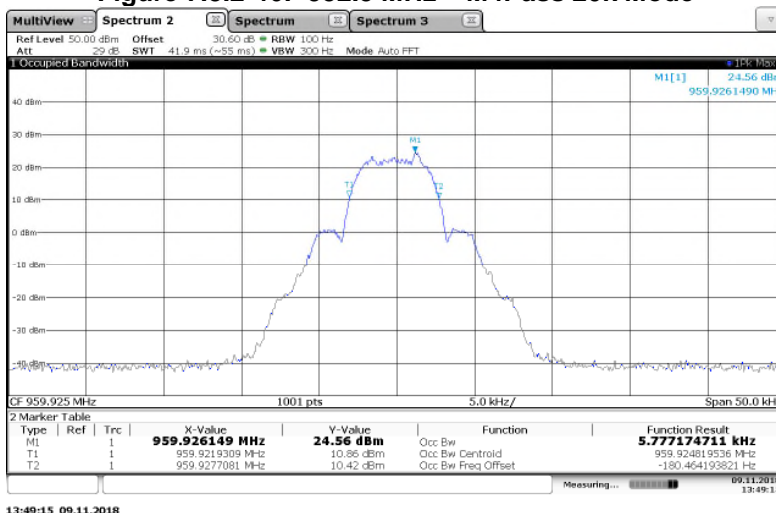

Figure 7.3.2-47: 959.925 MHz – MPass 5k Mode

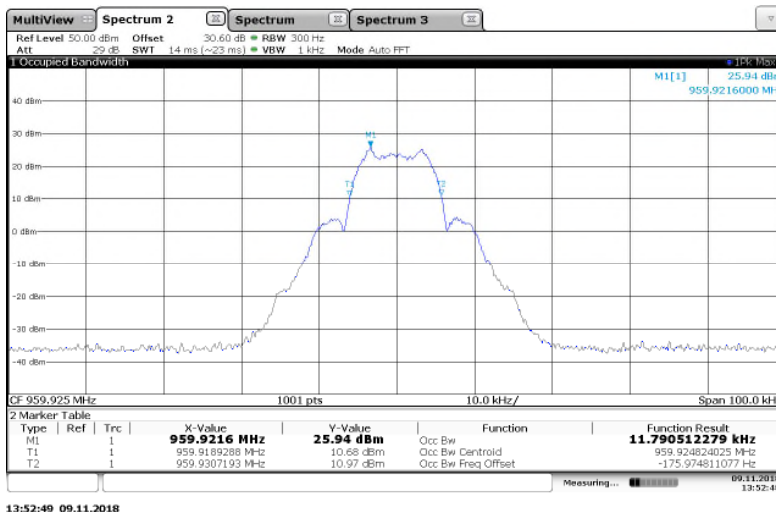

Figure 7.3.2-48: 959.925 MHz – MPass 10k Mode

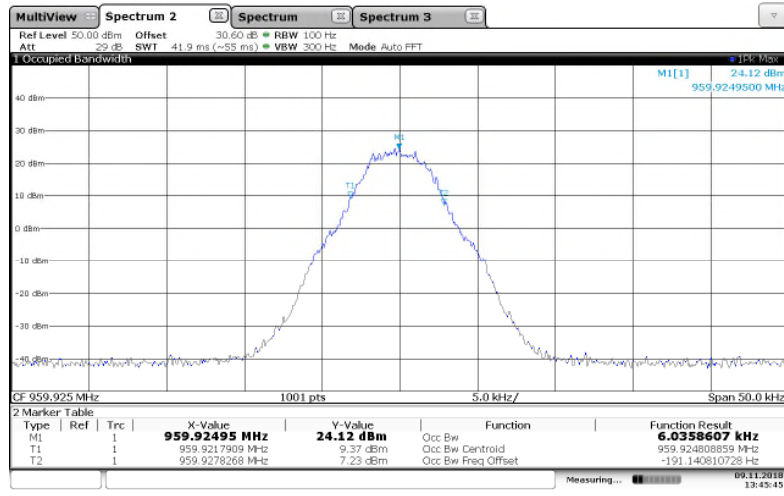

Figure 7.3.2-49: 959.925 MHz – M4Pass 10k Mode

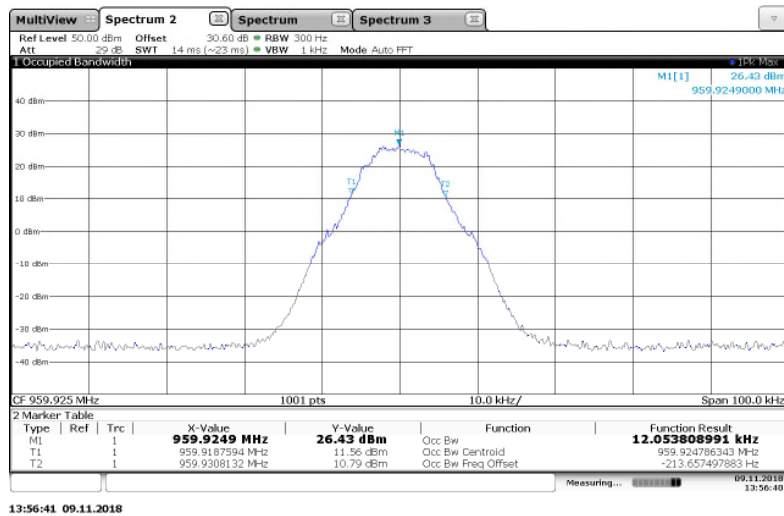

Figure 7.3.2-50: 959.925 MHz – M4Pass 20k Mode

7.4 Spurious Emissions at Antenna Terminals

7.4.1 Measurement Procedure (ANSI 63.26: 2015 Section 5.7.4)

The RF output of the equipment under test was directly connected to the input of the Spectrum Analyzer through 30.6dB of passive attenuation. The spectrum analyzer resolution bandwidth was set to 100 kHz below 1000 MHz and 1 MHz above 1000 MHz. The internal correction factors of the spectrum analyzer were employed to correct for any cable, attenuator or filter losses. The spectrum was investigated in accordance to CFR 47 Part 2.1057. There were no significant emissions from 9 kHz or lowest frequency generated to 30 MHz. Results are shown below.

7.4.2 Measurement Results

Performed by: Ben Ford

Part 24.133 a(1), a(2), ISED Canada RSS-134 4.4.1 (a), (b), 4.4.2 (a), (b) TXC

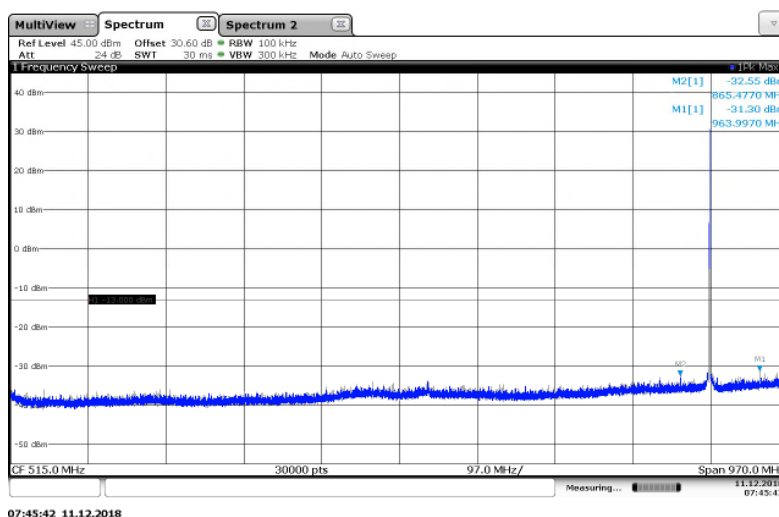

Figure 7.4.2-1: 901.5 MHz – 30MHz to 1GHz – Normal mode

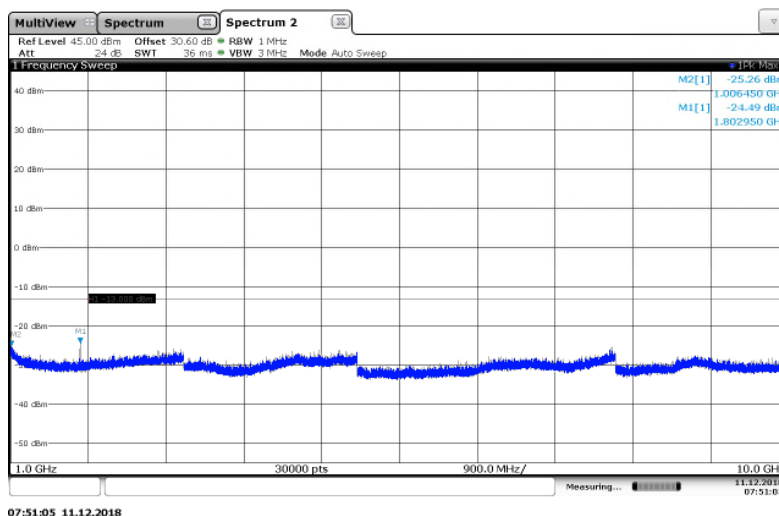

Figure 7.4.2-2: 901.5 MHz – 1GHz to 10GHz – Normal mode

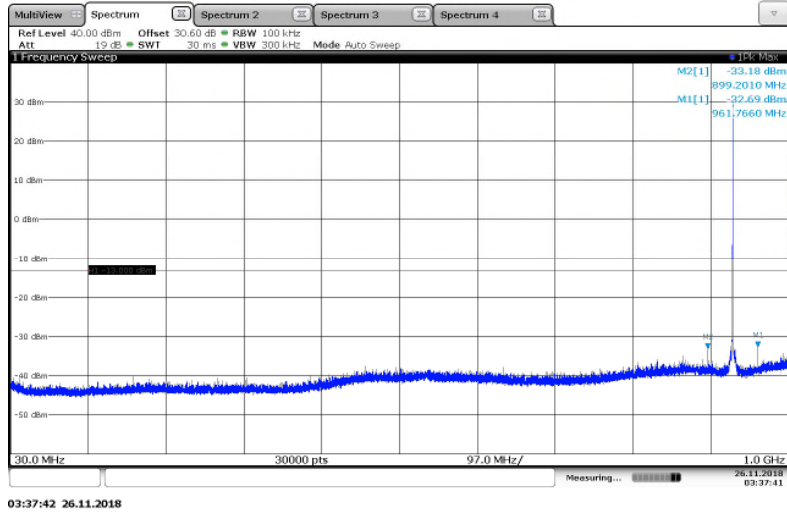

Figure 7.4.2-3: 930.5 MHz – 30MHz to 1GHz – Mpass5k mode

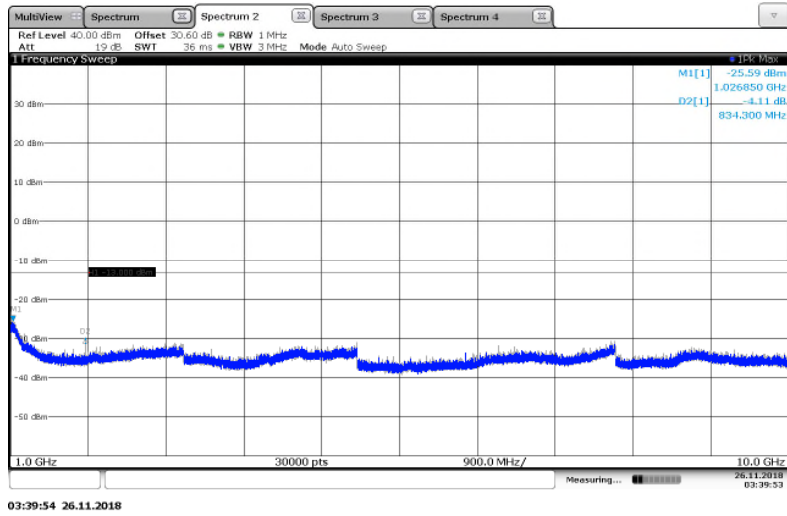

Figure 7.4.2-4: 930.5 MHz – 1GHz to 10GHz – Mpass 5k mode

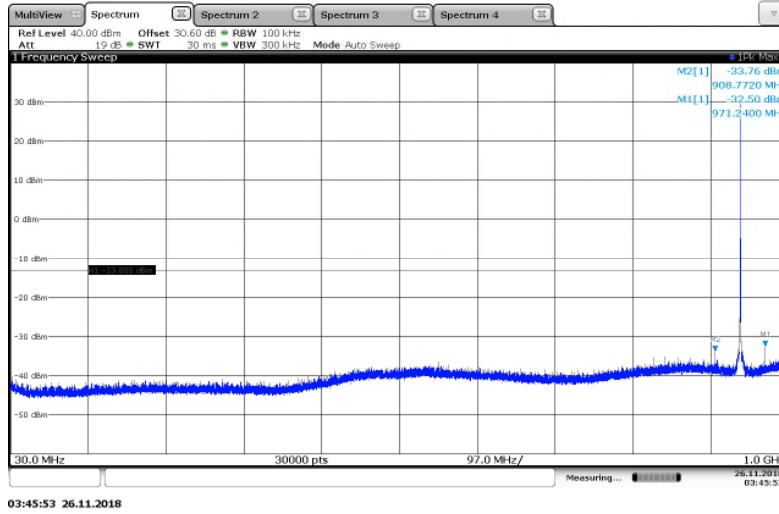

Figure 7.4.2-5: 940.0125 MHz – 30MHz to 1GHz – Mpass5k mode

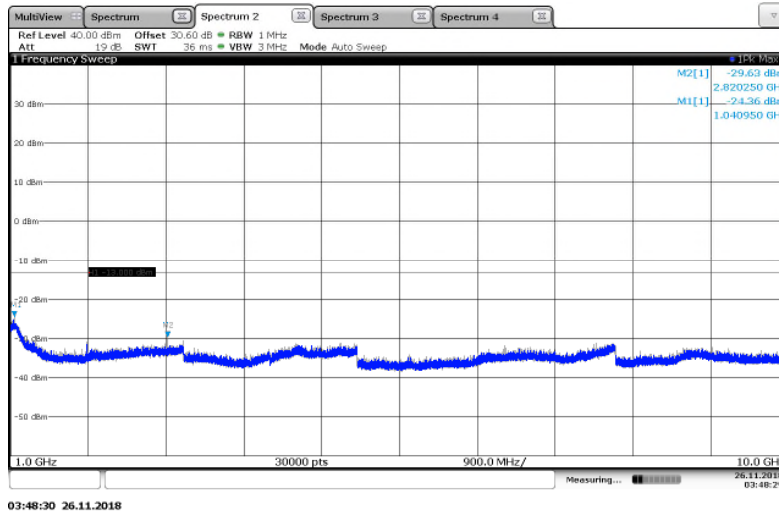

Figure 7.4.2-6: 940.0125 MHz – 1GHz to 10GHz – Mpass5k mode

Part 101.111 a(6), RSS-119 5.8.6

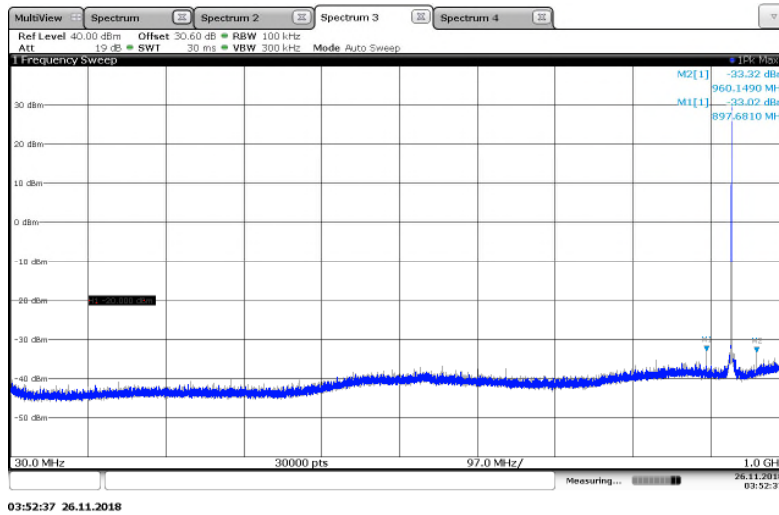

Figure 7.4.2-7: 928.925 MHz – 30MHz to 1GHz – Normal mode

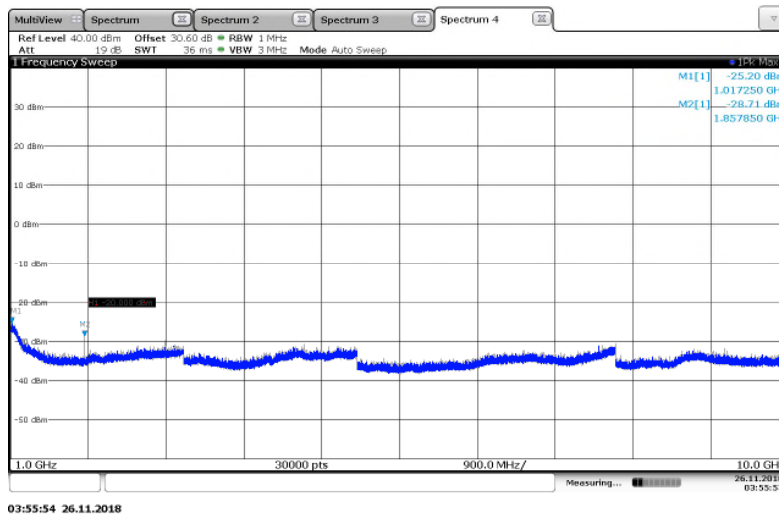

Figure 7.4.2-8: 928.925 MHz – 1GHz to 10GHz – Normal mode

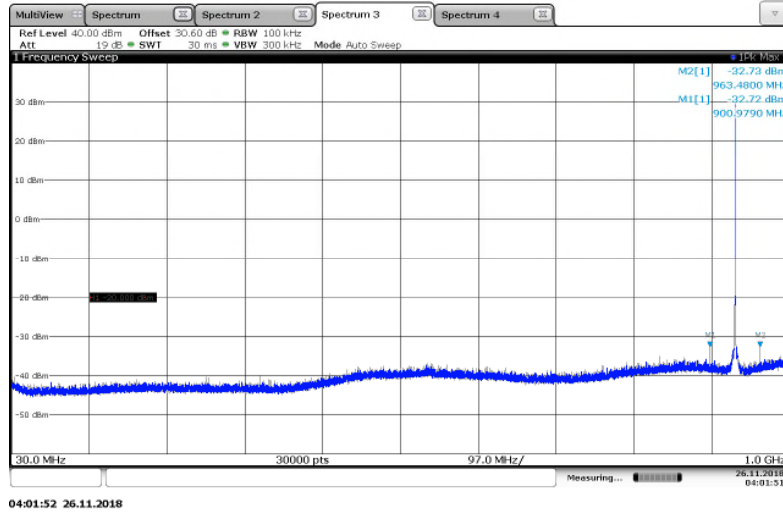

Figure 7.4.2-9: 932.25 MHz – 30MHz to 1GHz – Normal mode

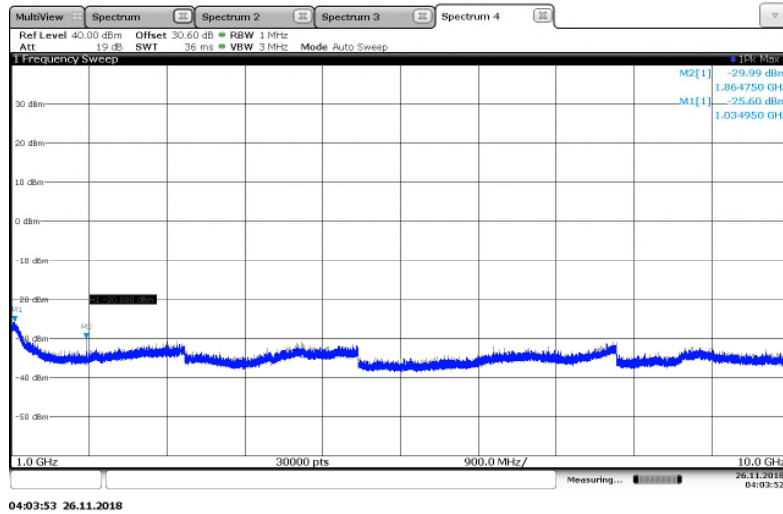

Figure 7.4.2-10: 932.25 MHz – 1GHz to 10GHz – Normal mode

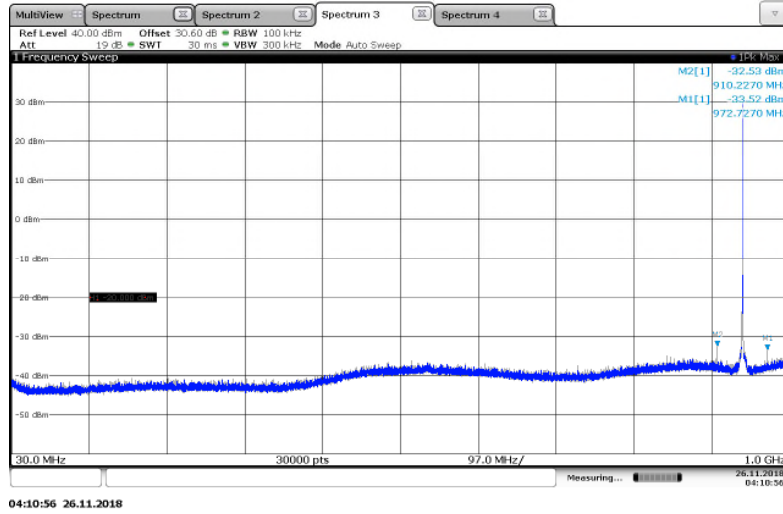

Figure 7.4.2-11: 941.4875 MHz – 30MHz to 1GHz – Mpass5k mode

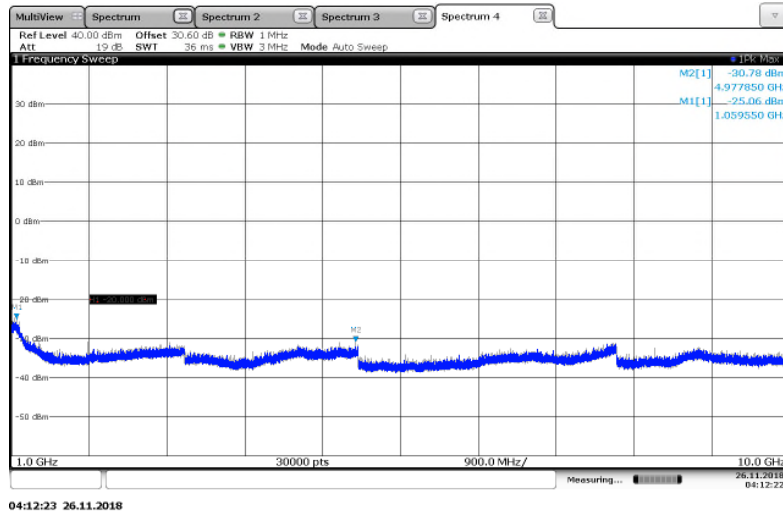

Figure 7.4.2-12: 941.4875 MHz – 1GHz to 10GHz – Mpass5k mode

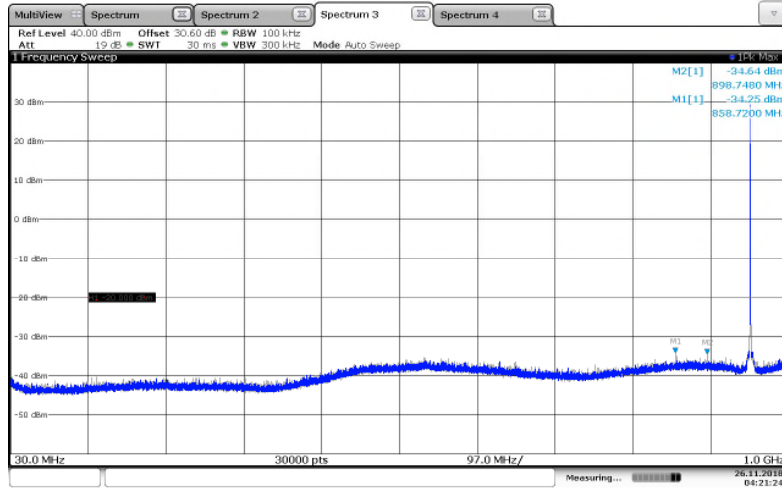

Figure 7.4.2-13: 952.5 MHz – 30MHz to 1GHz – Mpass5k mode

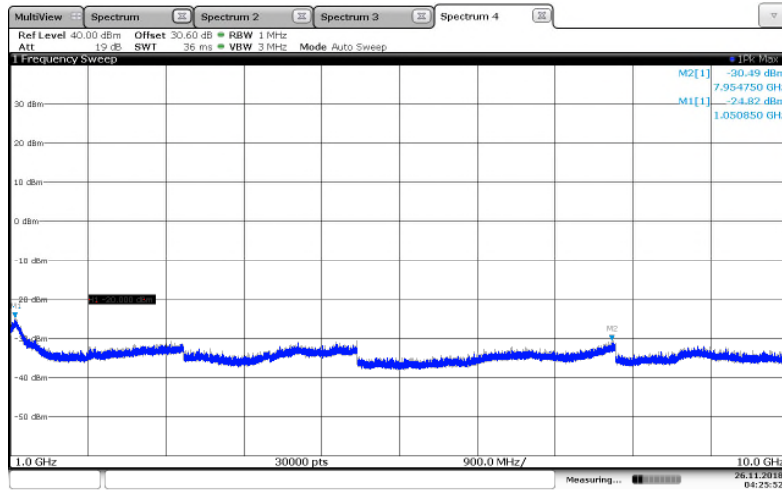

Figure 7.4.2-14: 952.5 MHz – 1GHz to 10GHz – Mpass5k mode

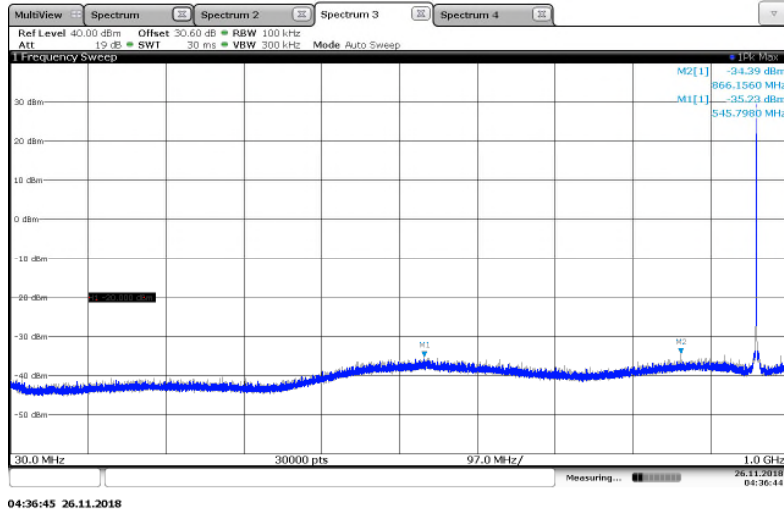

Figure 7.4.2-15: 959.925 MHz – 30MHz to 1GHz – Mpass5k mode

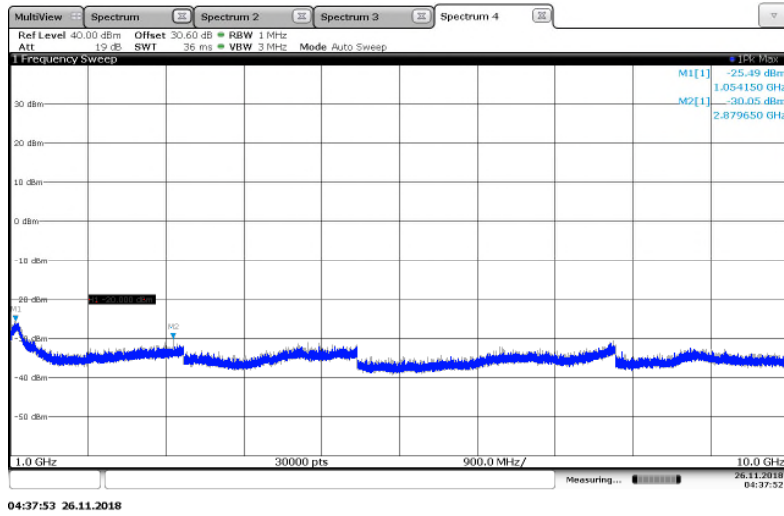

Figure 7.4.2-16: 959.925 MHz – 1GHz to 10GHz – Mpass5k mode

7.5 Field Strength of Spurious Emissions

7.5.1 Measurement Procedure (ANSI 63.26: 2015 Section 5.5.2.3.1)

The equipment under test is placed in the Semi-Anechoic Chamber (described in section 2.3.1) on a table at the turntable center. Below 1 GHz the table height was 80cm and above 1 GHz the table height was 1.5m. For each spurious emission, the antenna mast is raised and lowered from one (1) to four (4) meters and the turntable is rotated 360° and the maximum reading on the spectrum analyzer is recorded. This was repeated for both horizontal and vertical polarizations of the receive antenna.

The equipment under test is then replaced with a substitution antenna fed by a signal generator. The signal generator's frequency is set to that of the spurious emission recorded from the equipment under test. The antenna mast is raised and lowered from one (1) to four (4) meters to obtain a maximum reading on the spectrum analyzer. The output of the signal generator is then adjusted until the reading on the spectrum analyzer matches that obtained from the equipment under test. The signal generator level is recorded. The power in dBm of each spurious emission is calculated by correcting the signal generator level for the cable loss and gain of the substitution antenna referenced to a dipole. The spectrum was investigated in accordance to CFR 47 Part 2.1057.

The magnitude of all spurious emissions not reported were attenuated below the noise floor of the measurement system and therefore not specified in this report. Results are shown below.

7.5.2 Measurement Results

Performed by: Ben Ford

Part 24.133 a(1), a(2), RSS-134 4.4.1 (a), (b), 4.4.2 (a), (b)

EPSON

Table 7.5.2-1: Field Strength of Spurious Emissions – 901.5 MHz – Normal Mode

Frequency (MHz)	Spectrum Analyzer Level (dBμV)	Antenna Polarity (H/V)	Spurious ERP (dBm)	Limit (dBm)	Margin (dB)
1141	63.4	H	-40.19	-13.00	27.19
1141	59	V	-45.89	-13.00	32.89
1803	58.6	H	-45.18	-13.00	32.18
1803	52.1	V	-51.58	-13.00	38.58
2704.5	53.5	H	-47.65	-13.00	34.65
2704.5	55.1	V	-46.05	-13.00	33.05

NOTE: All frequencies not listed were below the noise floor of the spectrum analyzer.

Table 7.5.2-2: Field Strength of Spurious Emissions – 930.5 MHz – mPass 5k Mode

Frequency (MHz)	Spectrum Analyzer Level (dB μ V)	Antenna Polarity (H/V)	Spurious ERP (dBm)	Limit (dBm)	Margin (dB)
1146.2	62.4	H	-42.07	-13.00	29.07
1191.7	57	V	-49.11	-13.00	36.11
1861	55.7	H	-49.10	-13.00	36.10
1861	51.2	V	-53.20	-13.00	40.20
2791.5	55.5	H	-45.19	-13.00	32.19
2791.5	54.3	V	-47.19	-13.00	34.19

NOTE: All frequencies not listed were below the noise floor of the spectrum analyzer.

Table 7.5.2-3: Field Strength of Spurious Emissions – 940.0125 MHz – mPass 5k Mode

Frequency (MHz)	Spectrum Analyzer Level (dB μ V)	Antenna Polarity (H/V)	Spurious ERP (dBm)	Limit (dBm)	Margin (dB)
1138.8	62	H	-41.29	-13.00	28.29
1237.6	56.9	V	-49.95	-13.00	36.95
1880.025	53.2	H	-51.21	-13.00	38.21
1880.025	51.3	V	-53.01	-13.00	40.01
2820.0375	55.9	H	-44.81	-13.00	31.81
2820.0375	56.6	V	-44.61	-13.00	31.61

NOTE: All frequencies not listed were below the noise floor of the spectrum analyzer.

Part 101.111a(5) & a(6), RSS-119 5.8.6**Table 7.5.2-4: Field Strength of Spurious Emissions – 928.925 MHz – Normal Mode**

Frequency (MHz)	Spectrum Analyzer Level (dB μ V)	Antenna Polarity (H/V)	Spurious ERP (dBm)	Limit (dBm)	Margin (dB)
1138.4	62.2	H	-41.10	-20.00	21.10
1138.4	57.1	V	-47.30	-20.00	27.30
1857.85	54.4	H	-50.10	-20.00	30.10
1857.85	51.3	V	-52.80	-20.00	32.80
2786.775	55.4	H	-45.59	-20.00	25.59
2786.775	53.5	V	-47.99	-20.00	27.99

NOTE: All frequencies not listed were below the noise floor of the spectrum analyzer.

Table 7.5.2-5: Field Strength of Spurious Emissions – 932.25 MHz – Normal Mode

Frequency (MHz)	Spectrum Analyzer Level (dB μ V)	Antenna Polarity (H/V)	Spurious ERP (dBm)	Limit (dBm)	Margin (dB)
1138.9	62.2	H	-41.09	-20.00	21.09
1193.6	57.9	V	-48.00	-20.00	28.00
1864.5	55.7	H	-48.31	-20.00	28.31
1864.5	53.6	V	-49.91	-20.00	29.91
2796.75	55.5	H	-45.30	-20.00	25.30
2796.75	54.5	V	-46.90	-20.00	26.90

NOTE: All frequencies not listed were below the noise floor of the spectrum analyzer.

Table 7.5.2-6: Field Strength of Spurious Emissions – 941.4875 MHz – mPass 5k Mode

Frequency (MHz)	Spectrum Analyzer Level (dB μ V)	Antenna Polarity (H/V)	Spurious ERP (dBm)	Limit (dBm)	Margin (dB)
1144.3	61.6	H	-42.77	-20.00	22.77
1205.3	57	V	-49.06	-20.00	29.06
1882.975	52.8	H	-51.81	-20.00	31.81
1882.975	50	V	-54.51	-20.00	34.51
2824.4625	56.1	H	-44.61	-20.00	24.61
2824.4625	53.8	V	-47.81	-20.00	27.81

NOTE: All frequencies not listed were below the noise floor of the spectrum analyzer.

Table 7.5.2-7: Field Strength of Spurious Emissions – 952.5 MHz – mPass 5k Mode

Frequency (MHz)	Spectrum Analyzer Level (dB μ V)	Antenna Polarity (H/V)	Spurious ERP (dBm)	Limit (dBm)	Margin (dB)
1140.03	63.1	H	-40.64	-20.00	20.64
1187.71	58.2	V	-50.22	-20.00	30.22
1905	52	H	-51.77	-20.00	31.77
1905	50.1	V	-53.12	-20.00	33.12
2857.5	57	H	-45.83	-20.00	25.83
2857.5	57.2	V	-49.83	-20.00	29.83

NOTE: All frequencies not listed were below the noise floor of the spectrum analyzer.

Table 7.5.2-8: Field Strength of Spurious Emissions – 959.925 MHz – mPass 5k Mode

Frequency (MHz)	Spectrum Analyzer Level (dB μ V)	Antenna Polarity (H/V)	Spurious ERP (dBm)	Limit (dBm)	Margin (dB)
1141.38	67.9	H	-30.78	-20.00	10.78
1227	59.1	V	-37.98	-20.00	17.98
1919.85	51	H	-54.03	-20.00	34.03
1919.85	50	V	-56.23	-20.00	36.23
2879.775	56.4	H	-44.44	-20.00	24.44
2879.775	57.4	V	-49.84	-20.00	29.84

NOTE: All frequencies not listed were below the noise floor of the spectrum analyzer.

7.6 Frequency Stability

7.6.1 Measurement Procedure (ANSI C63.26 Section 5.6.3)

The equipment under test is placed inside an environmental chamber. The RF output is directly coupled to the input of the measurement equipment and a power supply is attached to the primary supply voltage.

Frequency measurements were made at the extremes of the of temperature range -30°C to $+50^{\circ}\text{C}$ and at intervals of 10°C at normal supply voltage. A period of time sufficient to stabilize all components of the equipment was allowed at each frequency measurement. The equipment operates at 20VDC. Measurements were made to the equipment under test at a temperature of 20°C and at 85% and 115% variation of 20VDC. The maximum variation of frequency was recorded.

At the clients request data for all TCX0 variants are included in the results below.

7.6.2 Measurement Results

Performed by: Ben Ford

Part 24.135, RSS-134 (4.5)

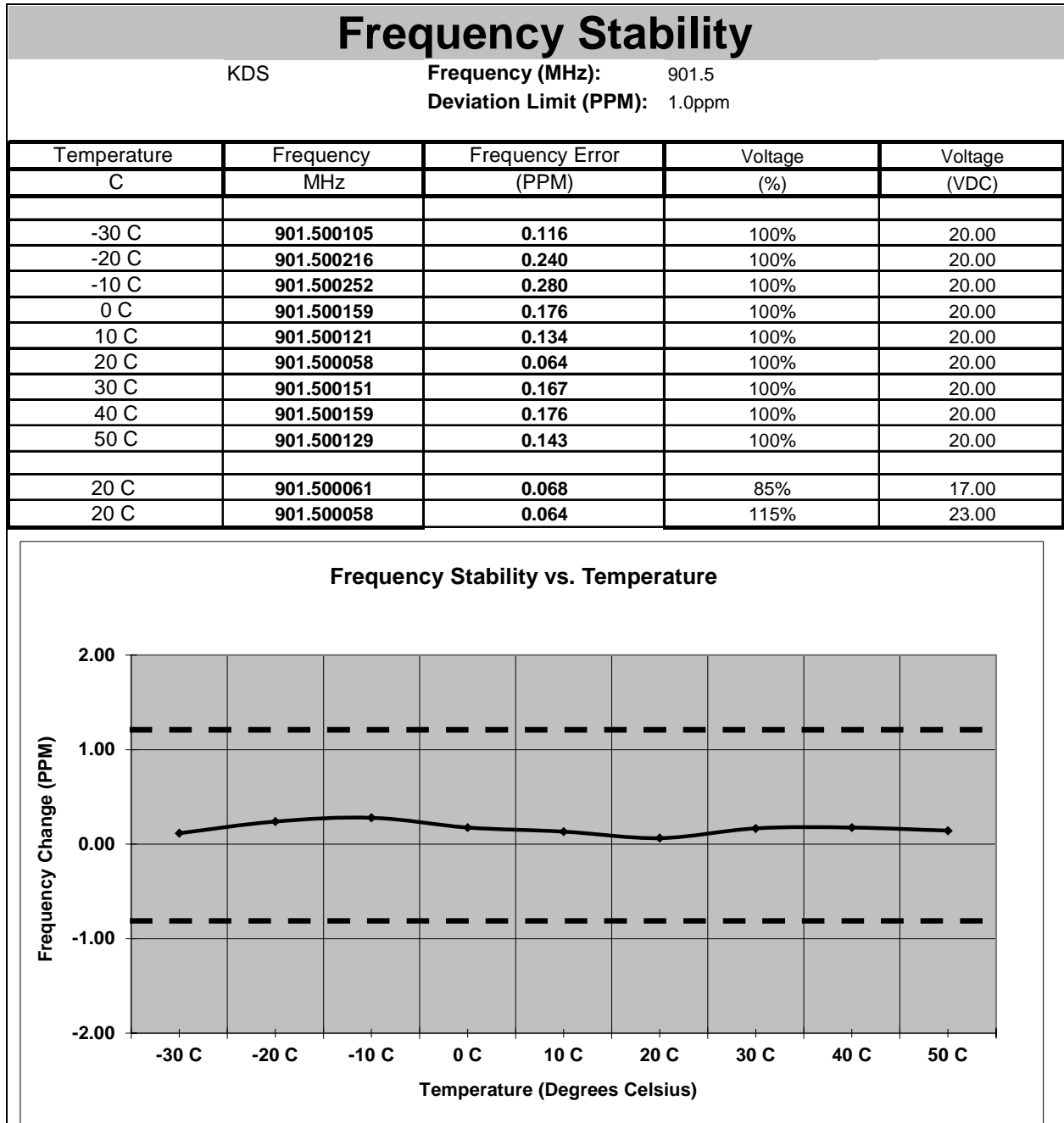

Figure 7.6.2-1: Frequency Stability – 901.5 MHz – KDS

Frequency Stability

TXC

Frequency (MHz): 901.5

Deviation Limit (PPM): 1.0ppm

Temperature C	Frequency MHz	Frequency Error (PPM)	Voltage (%)	Voltage (VDC)
-30 C	901.500679	0.753	100%	20.00
-20 C	901.500563	0.625	100%	20.00
-10 C	901.500719	0.798	100%	20.00
0 C	901.500706	0.783	100%	20.00
10 C	901.500588	0.652	100%	20.00
20 C	901.500571	0.633	100%	20.00
30 C	901.500674	0.748	100%	20.00
40 C	901.500783	0.869	100%	20.00
50 C	901.500782	0.867	100%	20.00
20 C	901.500559	0.620	85%	17.00
20 C	901.500583	0.647	115%	23.00

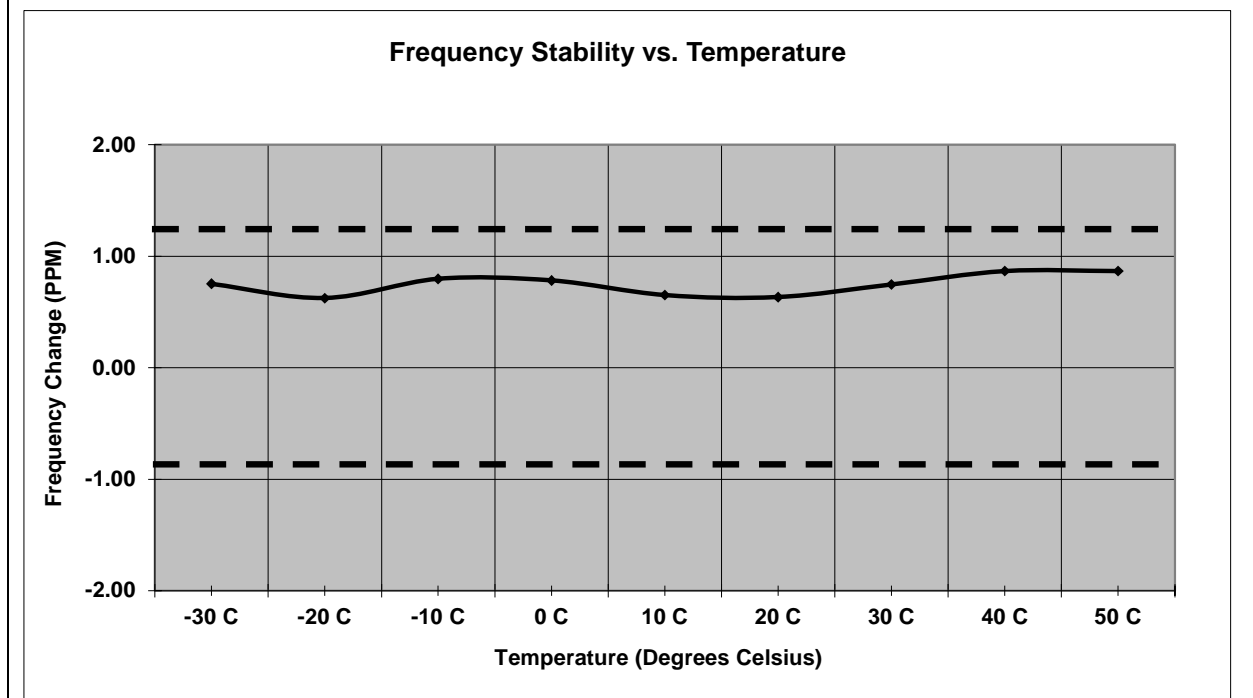

Figure 7.6.2-2: Frequency Stability – 901.5 MHz – TXC

Frequency Stability

EPSON

Frequency (MHz): 901.5

Deviation Limit (PPM): 1.0ppm

Temperature C	Frequency MHz	Frequency Error (PPM)	Voltage (%)	Voltage (VDC)
-30 C	901.500802	0.890	100%	20.00
-20 C	901.500518	0.575	100%	20.00
-10 C	901.500239	0.265	100%	20.00
0 C	901.500145	0.161	100%	20.00
10 C	901.499983	-0.019	100%	20.00
20 C	901.499863	-0.152	100%	20.00
30 C	901.499971	-0.032	100%	20.00
40 C	901.500186	0.206	100%	20.00
50 C	901.500354	0.393	100%	20.00
20 C	901.499851	-0.165	85%	17.00
20 C	901.499860	-0.155	115%	23.00

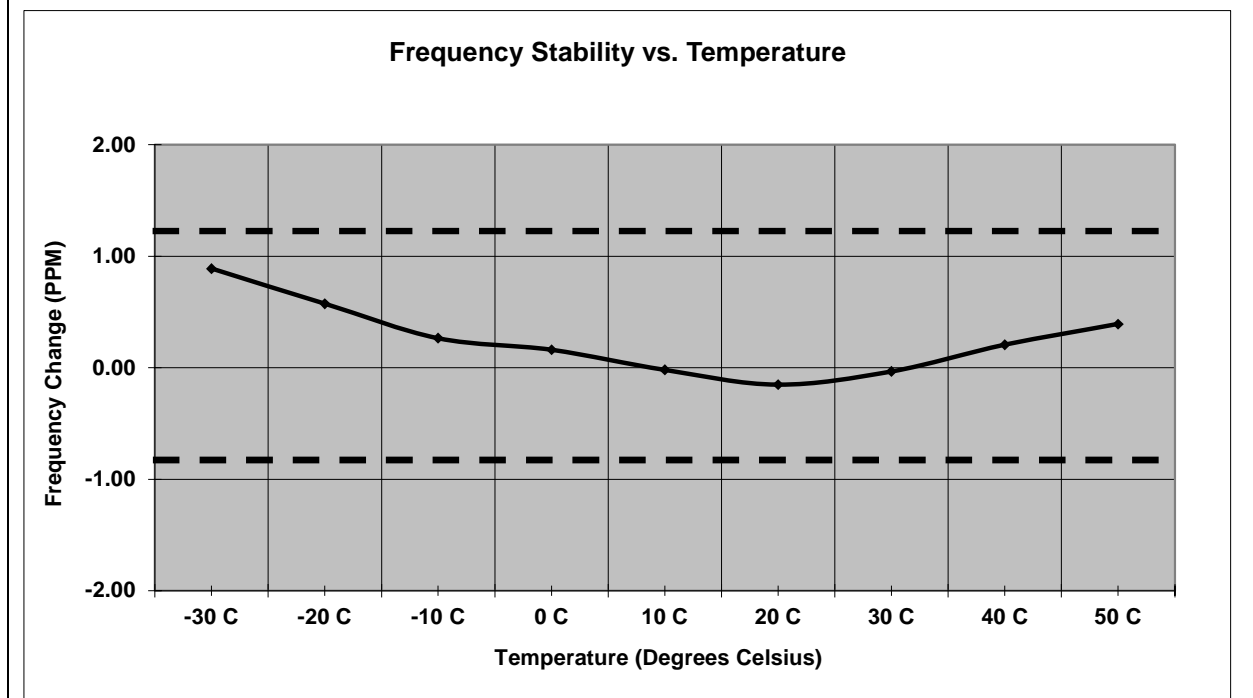

Figure 7.6.2-3: Frequency Stability – 901.5 MHz – EPSON

Frequency Stability

KDS

Frequency (MHz): 930.5

Deviation Limit (PPM): 1.0ppm

Temperature C	Frequency MHz	Frequency Error (PPM)	Voltage (%)	Voltage (VDC)
-30 C	930.500067	0.072	100%	20.00
-20 C	930.500174	0.187	100%	20.00
-10 C	930.500212	0.228	100%	20.00
0 C	930.500125	0.134	100%	20.00
10 C	930.500091	0.098	100%	20.00
20 C	930.500027	0.029	100%	20.00
30 C	930.500102	0.110	100%	20.00
40 C	930.500141	0.152	100%	20.00
50 C	930.500069	0.074	100%	20.00
20 C	930.500022	0.024	85%	17.00
20 C	930.500021	0.023	115%	23.00

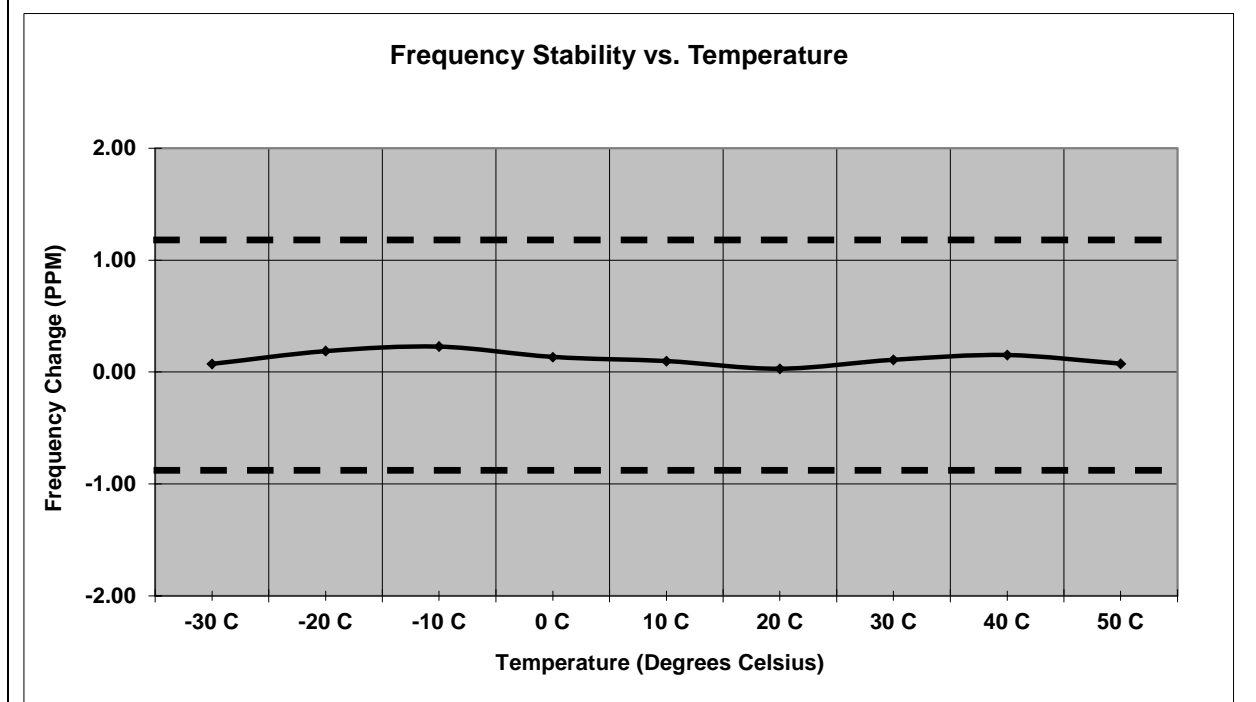

Figure 7.6.2-4: Frequency Stability – 930.5 MHz – KDS

Frequency Stability

TXC

Frequency (MHz): 930.5

Deviation Limit (PPM): 1.0ppm

Temperature C	Frequency MHz	Frequency Error (PPM)	Voltage (%)	Voltage (VDC)
-30 C	930.500656	0.705	100%	20.00
-20 C	930.500568	0.610	100%	20.00
-10 C	930.500451	0.485	100%	20.00
0 C	930.500685	0.736	100%	20.00
10 C	930.500702	0.754	100%	20.00
20 C	930.500544	0.585	100%	20.00
30 C	930.500603	0.648	100%	20.00
40 C	930.500772	0.830	100%	20.00
50 C	930.500718	0.772	100%	20.00
20 C	930.500531	0.571	85%	17.00
20 C	930.500549	0.590	115%	23.00

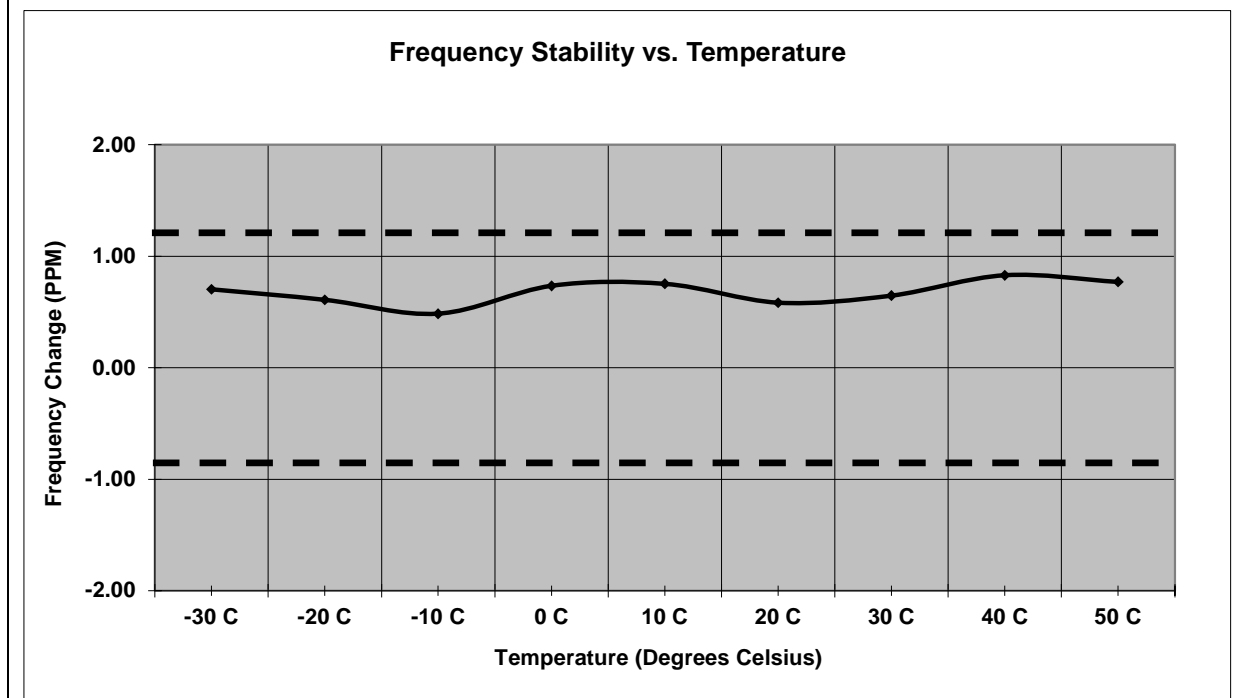

Figure 7.6.2-5: Frequency Stability – 930.5 MHz – TXC

Frequency Stability

EPSON

Frequency (MHz): 930.5

Deviation Limit (PPM): 1.0ppm

Temperature C	Frequency MHz	Frequency Error (PPM)	Voltage (%)	Voltage (VDC)
-30 C	930.500864	0.929	100%	20.00
-20 C	930.500554	0.595	100%	20.00
-10 C	930.500252	0.271	100%	20.00
0 C	930.500118	0.127	100%	20.00
10 C	930.499983	-0.018	100%	20.00
20 C	930.499824	-0.189	100%	20.00
30 C	930.499815	-0.199	100%	20.00
40 C	930.500135	0.145	100%	20.00
50 C	930.500301	0.323	100%	20.00
20 C	930.499822	-0.191	85%	17.00
20 C	930.499815	-0.199	115%	23.00

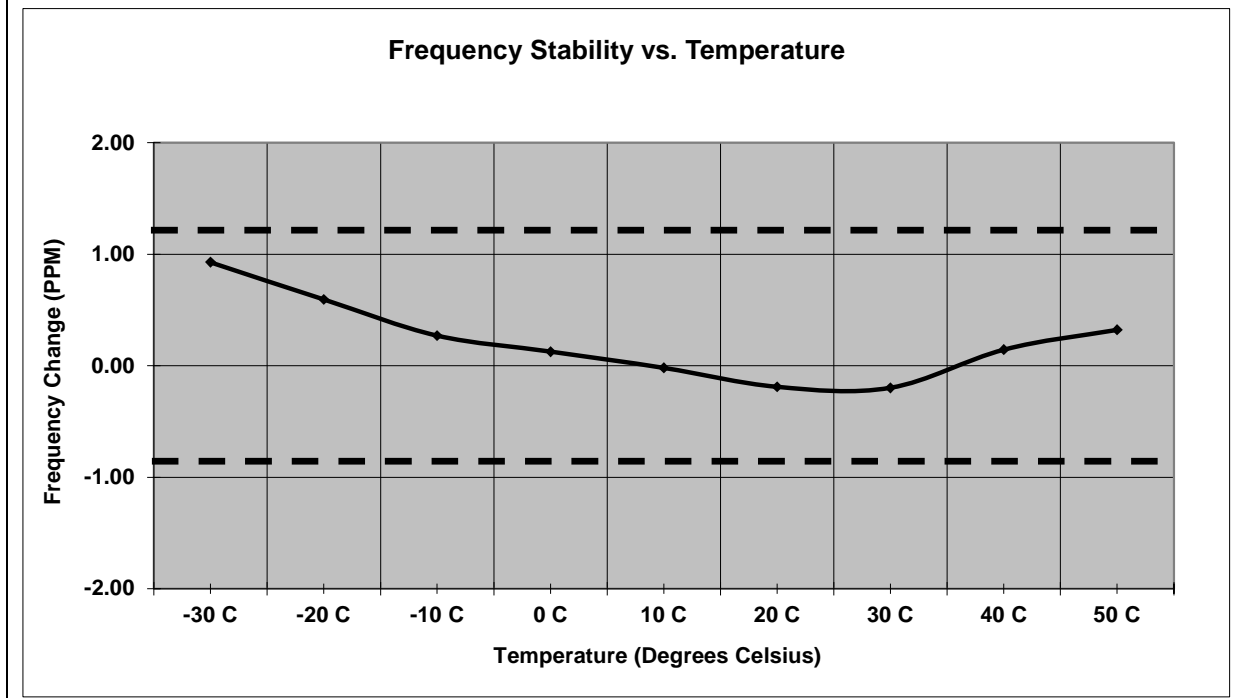

Figure 7.6.2-6: Frequency Stability – 930.5 MHz – EPSON

Part 101.107, RSS-119 5.3

Frequency Stability				
KDS		Frequency (MHz):	959.925	
		Deviation Limit (PPM):	1.0ppm	
Temperature	Frequency	Frequency Error	Voltage	Voltage
C	MHz	(PPM)	(%)	(VDC)
-30 C	959.925088	0.092	100%	20.00
-20 C	959.925132	0.138	100%	20.00
-10 C	959.925218	0.227	100%	20.00
0 C	959.925142	0.148	100%	20.00
10 C	959.925101	0.105	100%	20.00
20 C	959.925030	0.031	100%	20.00
30 C	959.925082	0.085	100%	20.00
40 C	959.925153	0.159	100%	20.00
50 C	959.925078	0.081	100%	20.00
20 C	959.925092	0.096	85%	17.00
20 C	959.925026	0.027	115%	23.00

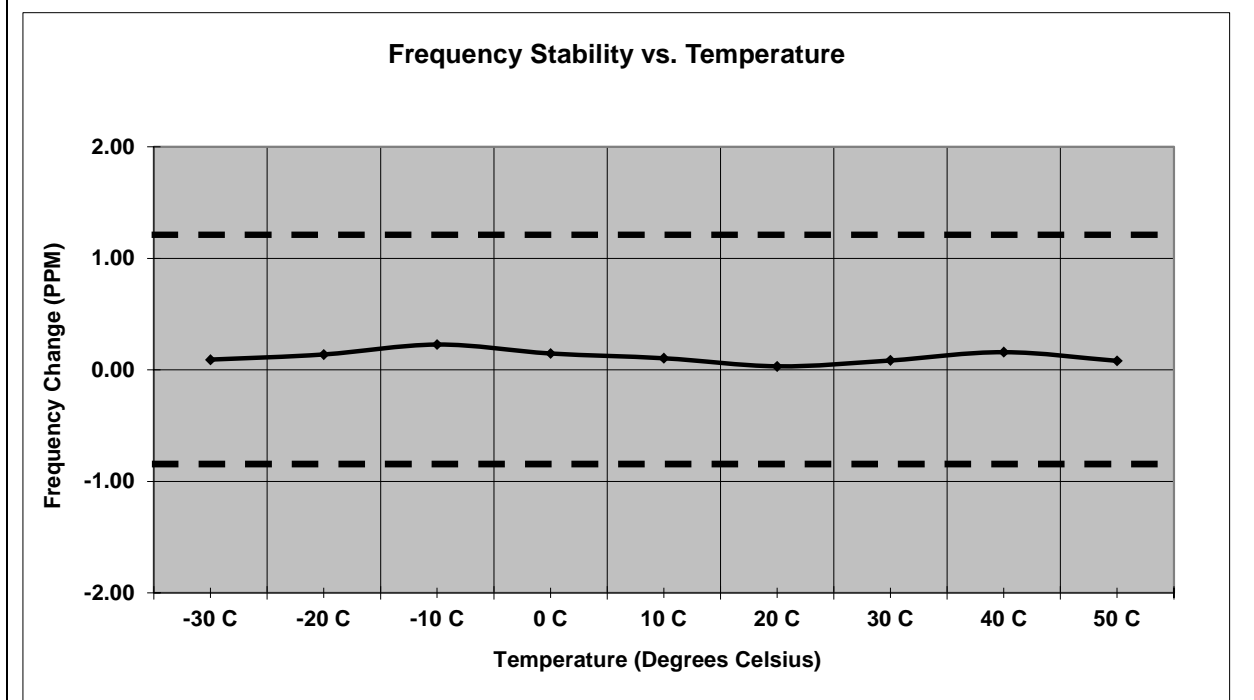

Figure 7.6.2-7: Frequency Stability – 959.925 MHz – KDS

Frequency Stability

TXC

Frequency (MHz): 959.925

Deviation Limit (PPM): 1.0ppm

Temperature C	Frequency MHz	Frequency Error (PPM)	Voltage (%)	Voltage (VDC)
-30 C	959.925654	0.681	100%	20.00
-20 C	959.925588	0.613	100%	20.00
-10 C	959.925479	0.499	100%	20.00
0 C	959.925668	0.696	100%	20.00
10 C	959.925738	0.769	100%	20.00
20 C	959.925556	0.579	100%	20.00
30 C	959.925584	0.608	100%	20.00
40 C	959.925799	0.832	100%	20.00
50 C	959.925723	0.753	100%	20.00
20 C	959.925554	0.577	85%	17.00
20 C	959.925558	0.581	115%	23.00

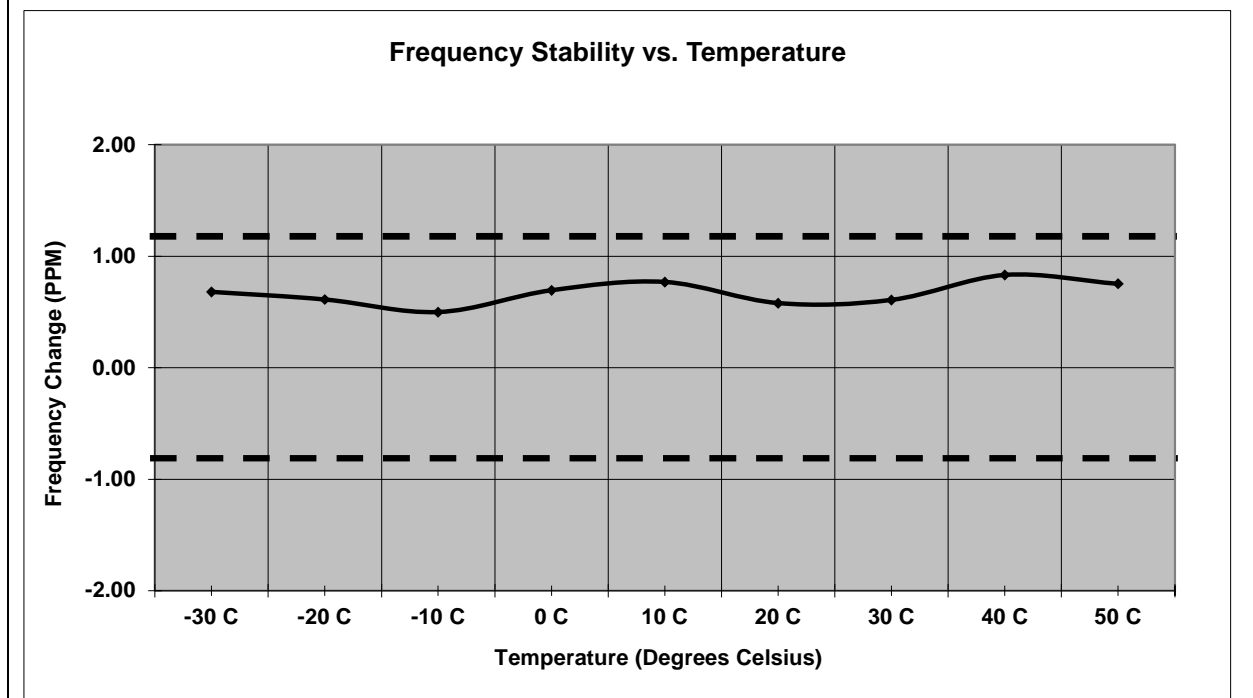

Figure 7.6.2-8: Frequency Stability – 959.925 MHz – TXC

Frequency Stability

EPSON

Frequency (MHz): 959.925

Deviation Limit (PPM): 1.0ppm

Temperature C	Frequency MHz	Frequency Error (PPM)	Voltage (%)	Voltage (VDC)
-30 C	959.925863	0.899	100%	20.00
-20 C	959.925524	0.546	100%	20.00
-10 C	959.925235	0.245	100%	20.00
0 C	959.925075	0.078	100%	20.00
10 C	959.924942	-0.060	100%	20.00
20 C	959.924781	-0.228	100%	20.00
30 C	959.924725	-0.286	100%	20.00
40 C	959.925012	0.013	100%	20.00
50 C	959.925222	0.231	100%	20.00
20 C	959.924780	-0.229	85%	17.00
20 C	959.924773	-0.236	115%	23.00

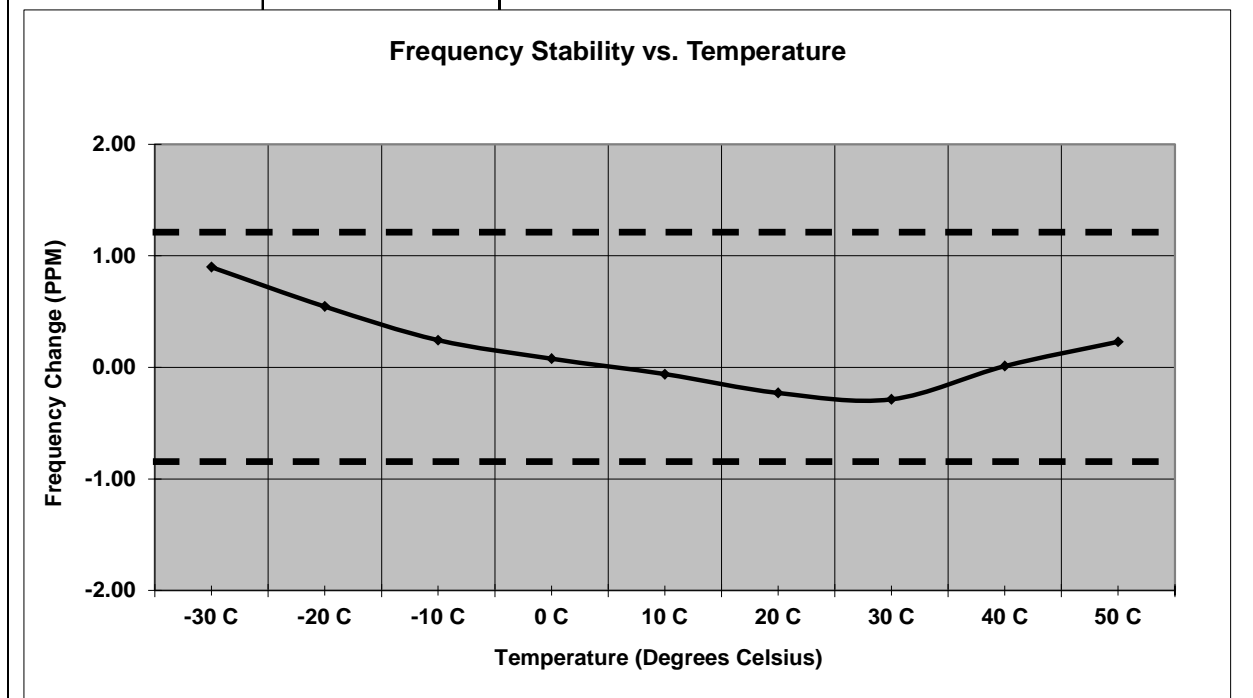

Figure 7.6.2-9: Frequency Stability – 959.925 MHz – EPSON

8.0 MEASUREMENT UNCERTAINTY

The expanded laboratory measurement uncertainty figures (U_{Lab}) provided below correspond to an expansion factor (coverage factor) $k = 1.96$ which provide confidence levels of 95%.

Parameter	U_{lab}
Occupied Channel Bandwidth	$\pm 0.004\%$
RF Conducted Output Power	± 0.689 dB
Power Spectral Density	± 0.5 dB
Antenna Port Conducted Emissions	± 2.717 dB
Radiated Emissions	± 5.877 dB
Temperature	± 0.860 °C
Radio Frequency	$\pm 2.832 \times 10^{-8}$
AC Power Line Conducted Emissions	± 2.85

9.0 CONCLUSION

In the opinion of TÜV SÜD America Inc. the model FLEXKV2C, manufactured by Sensus Metering Systems, Inc., meets all the requirements of FCC Part 24D and Part 101 as well as ISED Canada RSS-119 and RSS-134 where applicable.

End Report