

Certification Test Report

FCC ID: SDBCPTP100
IC: 2220A-CPTP100
FCC Rule Part: CFR 47 Part 24 Subpart D, Part 101 Subpart C
IC Radio Standards Specification: RSS 119, RSS 134

ACS Report Number: 15-3054.W06.1A

Applicant: Sensus Metering Systems, Inc.
Model: CPTP100

Test Begin Date: February 3, 2016
Test End Date: February 15, 2016

Report Issue Date: March 23, 2016



For The Scope of Accreditation Under Certificate Number AT-1921

This report must not be used by the client to claim product certification, approval, or endorsement by ANAB, ANSI, or any agency of the Federal Government.

Project Manager:



Mario de Aranzeta
Lab Manager Durham (RTP)
Advanced Compliance Solutions, Inc.

Reviewed by:



Kirby Munroe
Director, Wireless Certifications
Advanced Compliance Solutions, Inc.

This test report shall not be reproduced except in full. This report may be reproduced in part with prior written consent of ACS, Inc. The results contained in this report are representative of the sample(s) submitted for evaluation.

This report contains 58 pages

Table of Contents

1.0 GENERAL	3
1.1 PURPOSE.....	3
1.2 PRODUCT DESCRIPTION.....	3
1.3 TEST METHODOLOGY.....	3
1.4 EMISSION DESIGNATORS.....	5
2.0 TEST FACILITIES	6
2.1 LOCATION	6
2.2 LABORATORY ACCREDITATIONS/RECOGNITIONS/CERTIFICATIONS.....	6
2.3 RADIATED & CONDUCTED EMISSIONS TEST SITE DESCRIPTION	7
3.0 APPLICABLE STANDARD REFERENCES	9
4.0 LIST OF TEST EQUIPMENT	10
5.0 SUPPORT EQUIPMENT	11
6.0 EQUIPMENT UNDER TEST SETUP BLOCK DIAGRAM	11
7.0 SUMMARY OF TESTS	12
7.1 RF POWER OUTPUT	12
7.2 OCCUPIED BANDWIDTH	17
7.3 SPURIOUS EMISSIONS AT ANTENNA TERMINALS	41
7.4 FIELD STRENGTH OF SPURIOUS EMISSIONS	50
7.5 FREQUENCY STABILITY.....	54
8.0 CONCLUSION	58

1.0 GENERAL

1.1 Purpose

The purpose of this report is to demonstrate compliance with Part 2 Subpart J, Part 24 Subpart D and Part 101 Subpart C of the FCC's Code of Federal Regulations, and Innovation, Science and Economic Development, Canada Radio Standards Specifications RSS-119 and RSS-134.

1.2 Product Description

The Cathodic Protection (CP) product is a system used to control the corrosion of a metal surface by making it the cathode of an electrochemical cell. The transceiver incorporated into the product uses the Sensus Metering Systems Flexnet wireless network for its telemetry.

Manufacturer Information:
Sensus Metering Systems, Inc.
639 Davis Drive
Morrisville, NC 27560

Test Sample Serial Numbers: 66 and 68. Sample 66 was used for conducted RF measurements and sample 68 for all the radiated measurements.

Test Sample Condition: The EUT was in good functional condition with no physical damages.

Test software provided by the manufacturer was used to exercise the EUT.

1.3 Test Methodology

1.3.1 Configurations and Justification

The EUT was evaluated in its normal operating orientation.

The evaluation for unintentional emission is documented separately in a verification report.

1.3.2 In-Band Testing Methodology

The EUT is designed to operate in multiple bands under the requirements of CFR 47 Parts 24 and 101. The following is a list of the frequency bands of operation sorted based on the FCC rule parts in which the band is associated.

CFR Title 47 Rule Part	Frequency Band of Operation (MHz)
24D	901.0 - 902.0
24D	930.0 - 931.0
24D	940.0 - 941.0
101	928.85 - 929.0
101	932.0 - 932.5
101	941.0 - 941.5
101	952.0 – 953.0
101	959.85 - 960.0

Based on the requirements set forth in accordance 47 CFR 2.1046-2.1057 as stated above, the methodology in selecting the places to test in the available bands of operation is outlined in the following table.

CFR Title 47 Rule Part	Frequency Band of Operation (MHz)	Location in the Range of Operation	Approx. Test Freq. MHz
24D	901.0 - 902.0	Middle	901.5000
101	928.85 - 929.0	Middle	928.9250
24D	930.0 - 931.0	Middle	930.5000
101	932.0 - 932.5	Middle	932.2500
24D	940.0 - 941.0	1 near top and 1 near bottom	940.0125
101	941.0 - 941.5		941.4875
101	952.0 – 953.0	Middle	952.5000
101	959.85 – 960.0	Middle	959.9250

1.4 Emission Designators

The CPTP100 transmitter produces six distinct modulation formats. The emission designators for the modulation types used by the CPTP100 transmitter were calculated using the baud rate defined in the Theory of Operation are as follows.

EMISSIONS DESIGNATORS:

Mode	Emission Designator	Modulation Type
Normal	9K60F2D	7-FSK
Double Density	9K60F2D	13-FSK
C&I (Half-Baud)	4K80F2D	7-FSK
Boost	1K10F2D	7-FSK
MPass (5 kbps)	5K90F1D	2-GFSK
MPass (10 kbps)	11K8F1D	2-GFSK

2.0 TEST FACILITIES

2.1 Location

The radiated and conducted emissions test sites are located at the following address:

Advanced Compliance Solutions, Inc.
2320 Presidential Dr. Suite 101
Durham NC 27703-8077
Phone: (919) 381-4235
www.acstestlab.com

FCC Test Firm Registration #: 637011
Industry Canada Lab Code: 20446

2.2 Laboratory Accreditations/Recognitions/Certifications

ACS (Durham) is accredited to ISO/IEC 17025 by ANSI-ASQ National Accreditation Board/ANAB accreditation program, and has been issued certificate number AT-1921 in recognition of this accreditation. Unless otherwise specified, all tests methods described within this report are covered under the ISO/IEC 17025 scope of accreditation.

2.3 Radiated & Conducted Emissions Test Site Description

2.3.1 Semi-Anechoic Chamber Test Site

The Semi-Anechoic Chamber Test Site consists of an 18' x 28' x 18' shielded enclosure. The chamber is lined with Samwha Electronics Co. LTD Ferrite Absorber, model number SFA300 (HSN-1). The ferrite tile is 10cm x 10 cm and weighs approximately 1.4lbs. These tiles are mounted on steel panels and installed directly on the inner walls of the chamber. On top of the ferrite tiles is DMAS HT-45 (Dutch Microwave Absorber Solutions) hybrid absorber on all walls except the wall behind the antenna mast which has a shorter DMAS HT-25 absorber.

The turntable is 1.50m in diameter and is located 150cm from the back wall of the chamber. The chamber is grounded via 1 - 8' copper ground rod, installed at the center of the back wall, it is bound to the ground plane using short #6 copper wire. The turntable is an aluminum, flush mounted table installed in an all steel frame. The table is remotely operated from inside the control room located 25' from the turntable. The turntable is electrically bonded to the surrounding ground plane via steel fingers installed on the edge of the turntable. The steel fingers make constant contact with the ground plane.

Behind the turntable is a 2' x 6' x 1.5' deep shielded pit used for support equipment if necessary. The pit is equipped with 2 - 4" PVC chase from the turntable to the pit that allow for cabling to the EUT if necessary. The underside of the turntable can be accessed from the pit so cables can be supplied to the EUT from the pit.

A diagram of the Semi-Anechoic Chamber Test Site is shown in Figure 2.3.1-1 below:

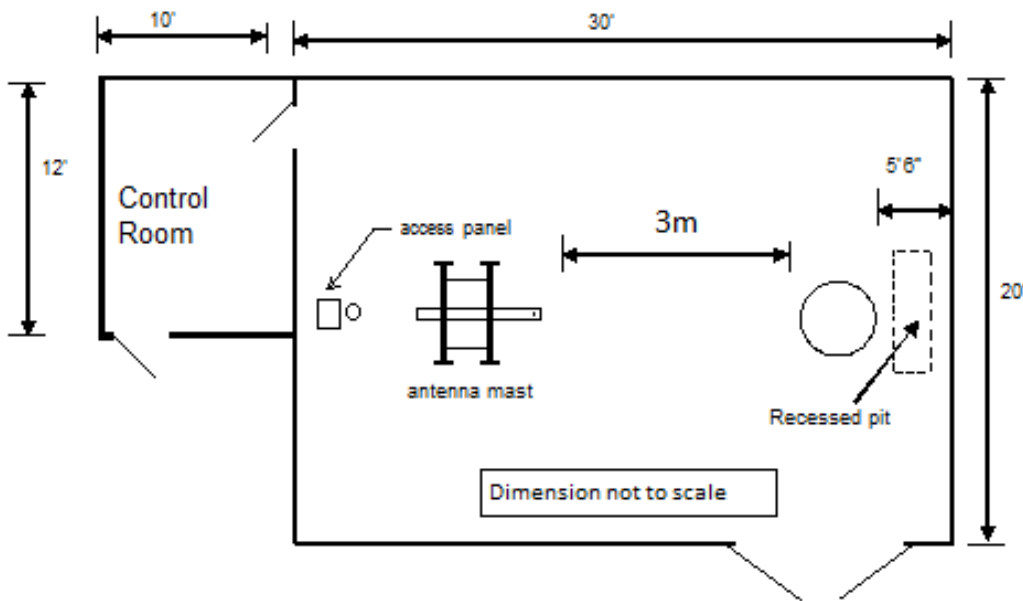

Figure 2.3.1-1: Semi-Anechoic Chamber Test Site

2.3.2 Conducted Emissions Test Site Description

The AC mains conducted EMI site is located in the main EMC lab. It consists of an 8' x 10' sheet galvanized steel horizontal ground reference plane (GRP) bonded every 6" to an 8' X 8' aluminum vertical ground plane.

A diagram of the room is shown below in figure 2.3.2-1:

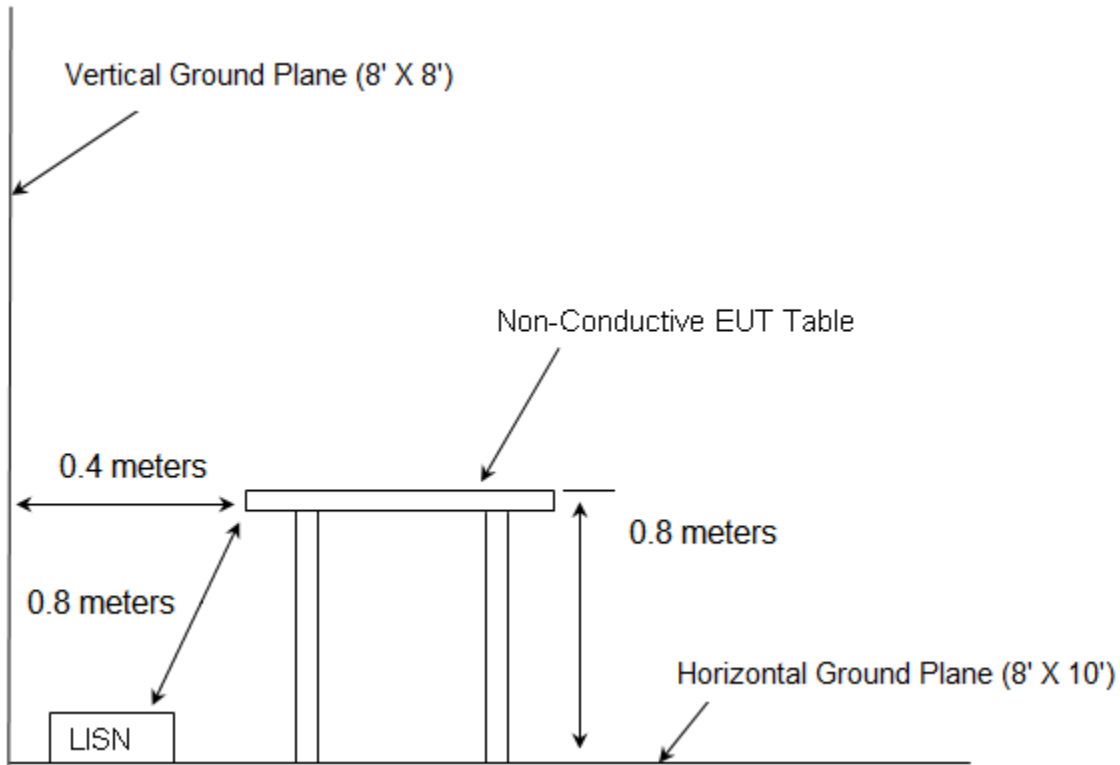

Figure 2.3.2-1: AC Mains Conducted EMI Site

3.0 APPLICABLE STANDARD REFERENCES

The following standards were used:

- 1 - ANSI C63.4-2014: Method of Measurements of Radio-Noise Emissions from Low-Voltage Electrical and Electronic Equipment in the 9 kHz to 40GHz - 2014
- 2 - US Code of Federal Regulations (CFR): Title 47, Part 2, Subpart J: Equipment Authorization Procedures - 2016
- 3 - US Code of Federal Regulations (CFR): Title 47, Part 24, Subpart D: Personal Communications Services – 2016
- 4 - US Code of Federal Regulations (CFR): Title 47, Part 101, Subpart C: Fixed Microwave Services - 2016
- 5 – TIA-603-D: Land Mobile FM or PM - Communications Equipment - Measurement and Performance Standards – 2010
- 6 – Industry Canada Radio Standards Specification: RSS-119 - Radio Transmitters and Receivers Operating in the Land Mobile and Fixed Services in the Frequency Range 27.41-960 MHz, Issue 12, May 2015
- 7 – Industry Canada Radio Standards Specification: RSS-134 - 900 MHz Narrow Band Personal Communication Service, Issue 2, February 2016
- 8 – Industry Canada Radio Standards Specification: RSS-GEN – General Requirements for Compliance of Radio Apparatus, Issue 4, November 2014.

4.0 LIST OF TEST EQUIPMENT

The calibration interval of test equipment is annually or the manufacturer's recommendations. Where the calibration interval deviates from the annual cycle based on the instrument manufacturer's recommendations, it shall be stated below.

Table 4-1: Test Equipment

AssetID	Manufacturer	Model #	Equipment Type	Serial #	Last Calibration Date	Calibration Due Date
3002	Rohde & Schwarz	ESU40	Receiver	100346	7/6/2015	7/6/2016
3038	Florida RF Labs	NMSE-290AW-60.0-NMSE	Cable Set	1448	12/22/2015	12/22/2016
3039	Florida RF Labs	NMSE-290AW-396.0-NMSE	Cable Set	1447	12/22/2015	12/22/2016
3016	Fei Teng Wireless Technology	HA-07M18G-NF	Antennas	2013120203	1/26/2016	1/26/2017
626	EMCO	3110B	Antennas	9411-1945	2/26/2014	2/26/2016
277	Emco	93146	Antennas	9904-5199	9/2/2014	9/2/2016
3006	Rohde & Schwarz	TS-PR18	Amplifiers	122006	6/29/2015	6/29/2016
3054	Mountain View Cable	BMS-RG400-36.0-BMS	Cables	3054	12/30/2015	12/30/2016
3020	Rohde & Schwarz	SMB100A	Signal Generators	175943	7/14/2015	7/14/2016
3033	Hasco, Inc.	HLL142-S1-S1-36	Cables	1435	1/7/2016	1/7/2017
3034	Hasco, Inc.	HLL142-S1-S-12	Cables	3076	12/30/2015	12/30/2016
3012	Rohde & Schwarz	EMC32-EB	Software	100731	1/19/2015	7/19/2016
3051	Mountain View Cable	BMS-RG400-264.0-BMS	Cables	3051	12/30/2015	12/30/2016
3055	Rohde & Schwarz	3005	Cables	3055	12/30/2015	12/30/2016
3029	Micro-Tronics	HPM50108	Filter	134	12/21/2015	12/21/2016
3041	Aeroflex Inmet	18N10W-30	Attenuator	1447	1/8/2016	1/8/2017
3042	Aeroflex Inmet	18N10W-10	Attenuator	1444	1/8/2016	1/8/2017

NCR = No Calibration Required

Firmware Version: ESU40 is 4.73 SP4

Software Version: EMC32-B is 9.15

5.0 SUPPORT EQUIPMENT

Table 5-1: EUT and Support Equipment

Item #	Type Device	Manufacturer	Model/Part #	Serial #
1	EUT	Sensus	CPTP100	68, 66
2	Power Supply	Sorensen	QRD-20-4	ACS 0351

Table 5-2: Cable Description

Cable #	Cable Type	Length	Shield	Termination
A	EUT	1.8m	No	Power supply
B	Power Supply	1.8m	No	Mains

6.0 EQUIPMENT UNDER TEST SETUP BLOCK DIAGRAM

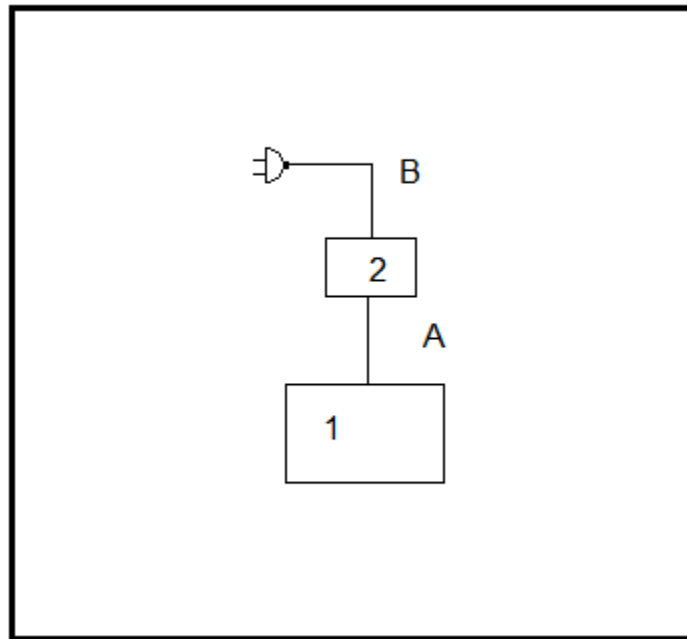

Figure 6-1: EUT Test Setup

7.0 SUMMARY OF TESTS

Along with the tabular data shown below, plots were taken of all signals deemed important enough to document.

7.1 RF Power Output

7.1.1 Measurement Procedure

The RF output of the equipment under test was directly connected to the input of the spectrum analyzer through 40.5 dB of passive attenuation. The internal correction factors of the spectrum analyzer were employed to correct for any cable or attenuator losses. The spectrum analyzer resolution bandwidth was set to 100 kHz.

7.1.2 Measurement Results

Part 24.132, 101.113 (a), and IC RSS-134 4.3 (a), (b) and RSS-119 5.4

Table 7.1.2-1: Peak Output Power

Frequency (MHz)	FCC Rule Part	Output Power (dBm)	Output Power Watts
901.5000	24D	30.34	1.08
930.5000	24D	30.22	1.05
940.0125	24D	30.10	1.02
928.9250	101	30.25	1.06
932.2500	101	30.17	1.04
941.4875	101	30.08	1.02
952.5000	101	29.95	0.99
959.9250	101	29.80	0.95

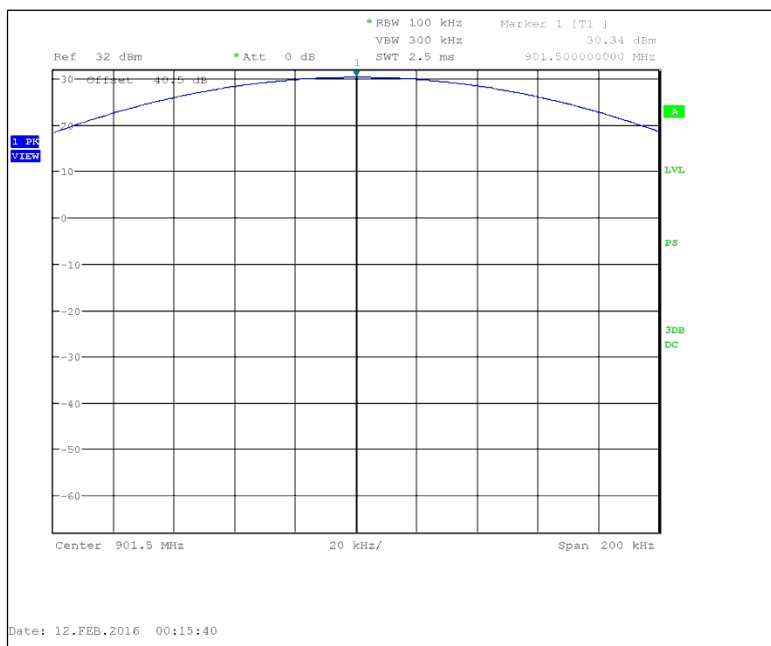

Figure 7.1.2-1: 901.5 MHz



Figure 7.1.2-4: 928.925 MHz



Figure 7.1.2-5: 932.25 MHz



Figure 7.1.2-6: 941.4875 MHz



Figure 7.1.2-7: 952.5 MHz



Figure 7.1.2-8: 959.925 MHz

7.2 Occupied Bandwidth

7.2.1 Measurement Procedure

The RF output of the equipment under test was directly connected to the input of the spectrum analyzer through 40.5 dB of passive attenuation for the FCC plots and for the IC plots. The spectrum analyzer resolution and video bandwidths were set to 300 Hz and 3000 Hz respectively. The internal correction factors of the spectrum analyzer were employed to correct for any cable or attenuator losses. Results of the test are shown below for all modes of operation.

7.2.2 Measurement Results – Emission Masks

Part 24.133 a(1), a(2), IC RSS-134 4.4.1, 4.4.2 – Emission Limits

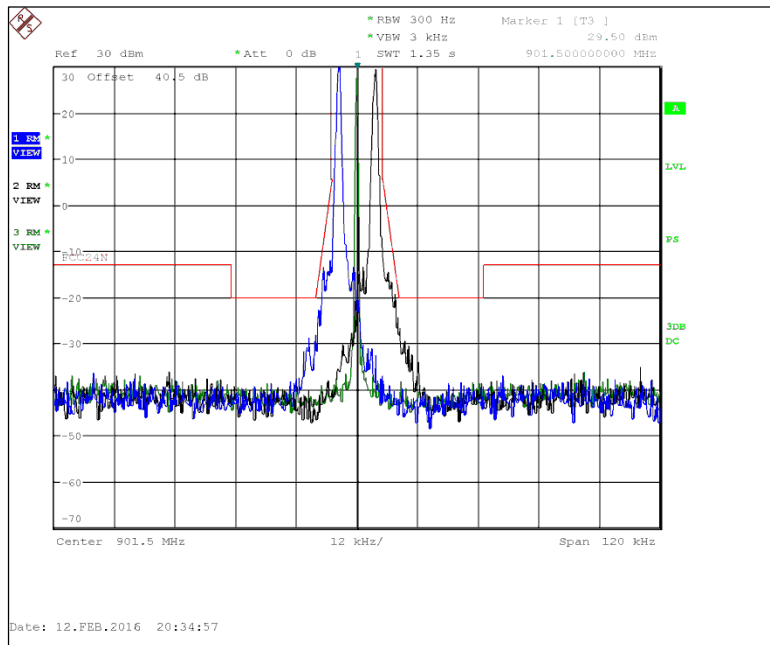

Figure 7.2.2-1: 901.5 MHz – 12.5 kHz Channel Spacing – Boost Mode

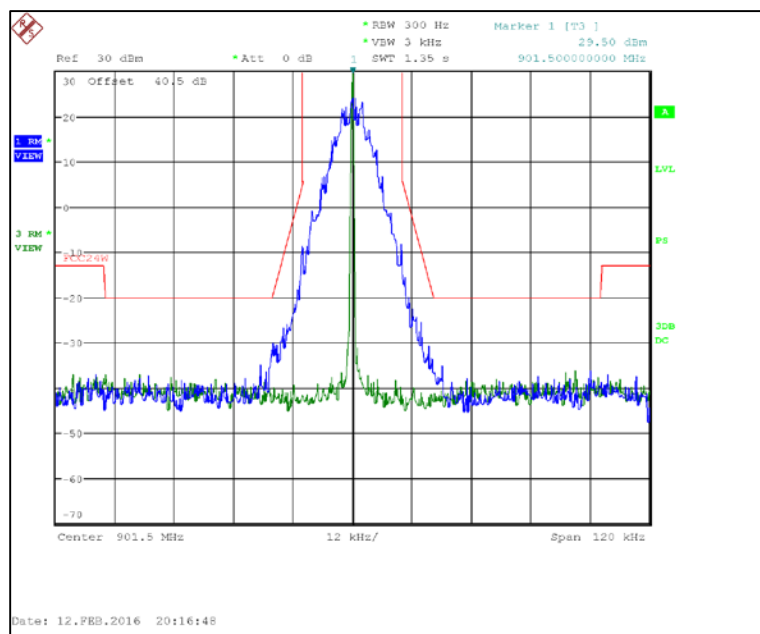

Figure 7.2.2-2: 901.5 MHz – 25 kHz Channel Spacing – Normal Mode

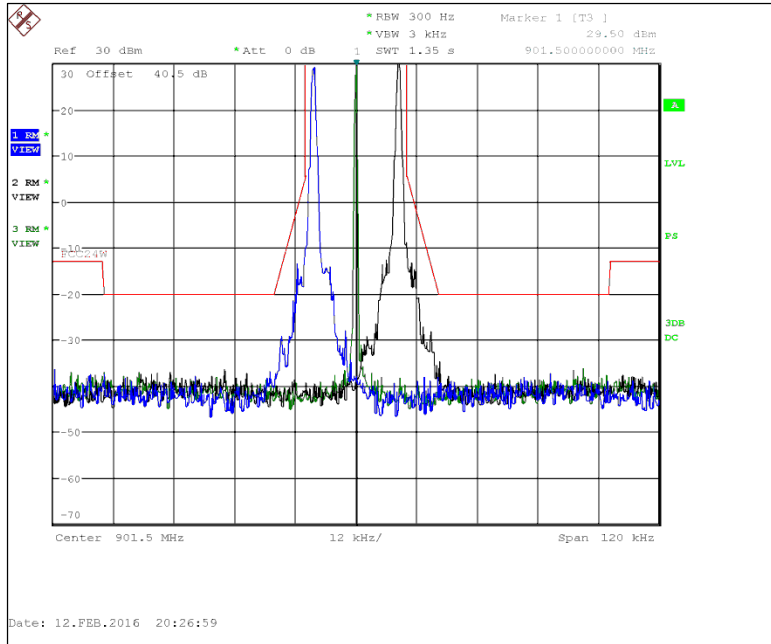

Figure 7.2.2-3: 901.5 MHz – 25 kHz Channel Spacing – Boost Mode

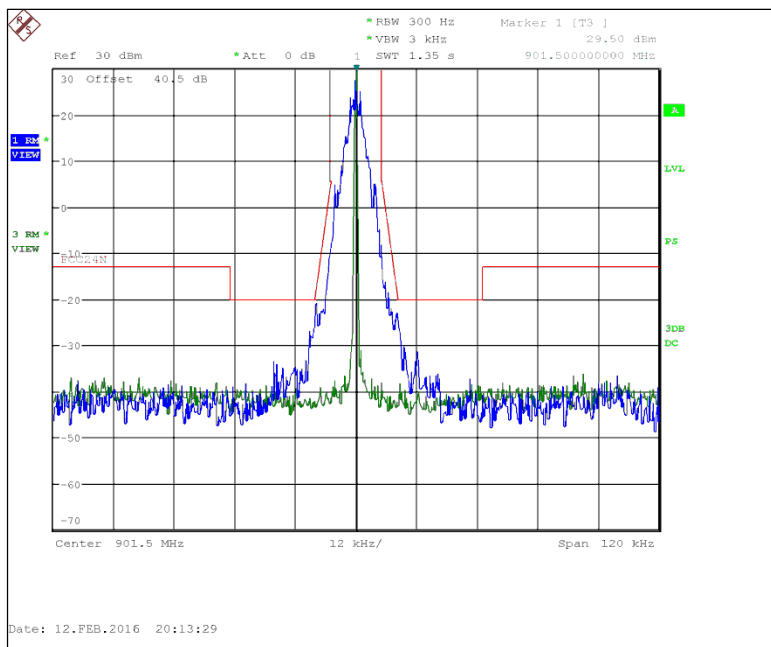

Figure 7.2.2-4: 901.5 MHz – 12.5 kHz Channel Spacing – C&I Mode

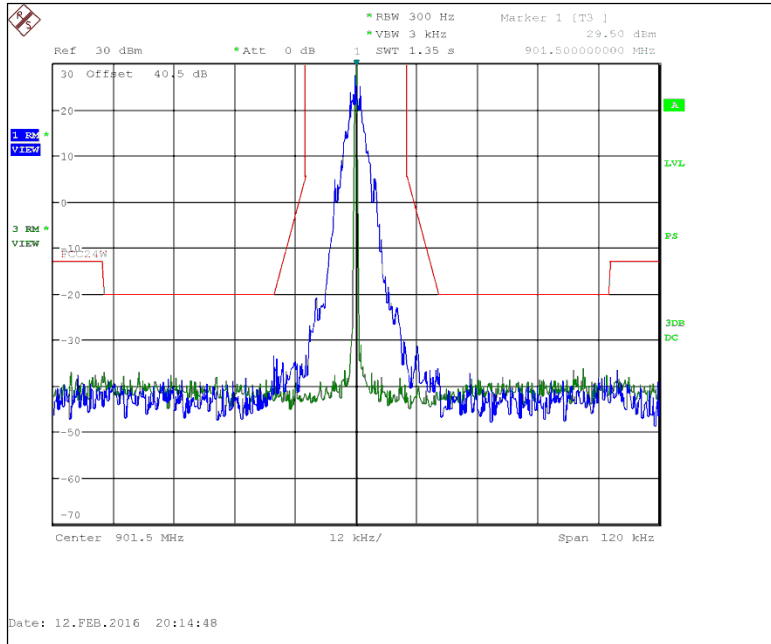

Figure 7.2.2-5: 901.5 MHz – 25 kHz Channel Spacing – C&I Mode

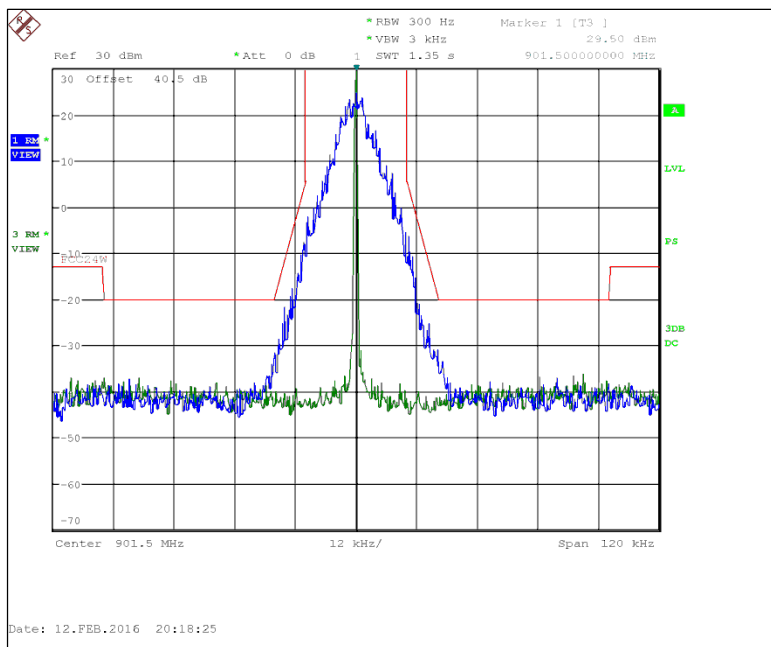

Figure 7.2.2-6: 901.5 MHz – 25 kHz Channel Spacing – Double Density Mode

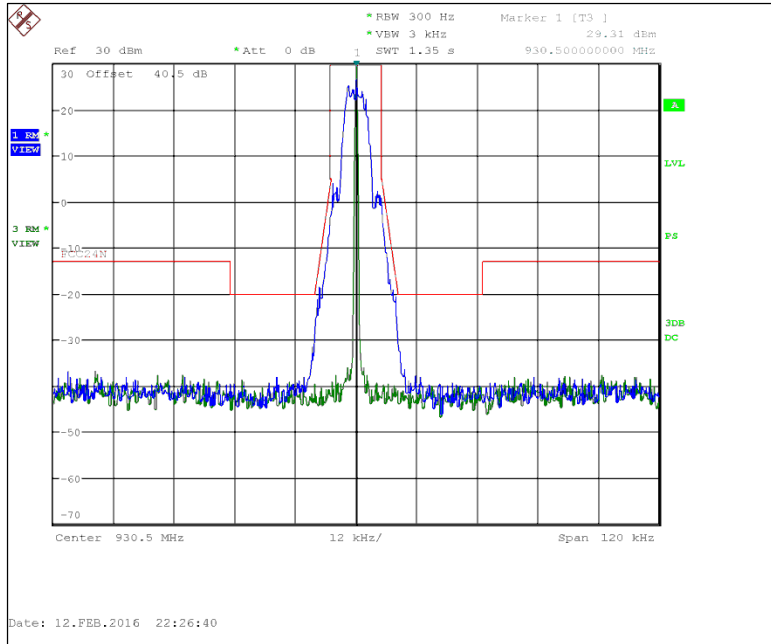

Figure 7.2.2-7: 930.5 MHz - 12.5 kHz Channel Spacing – mPass 5k Mode

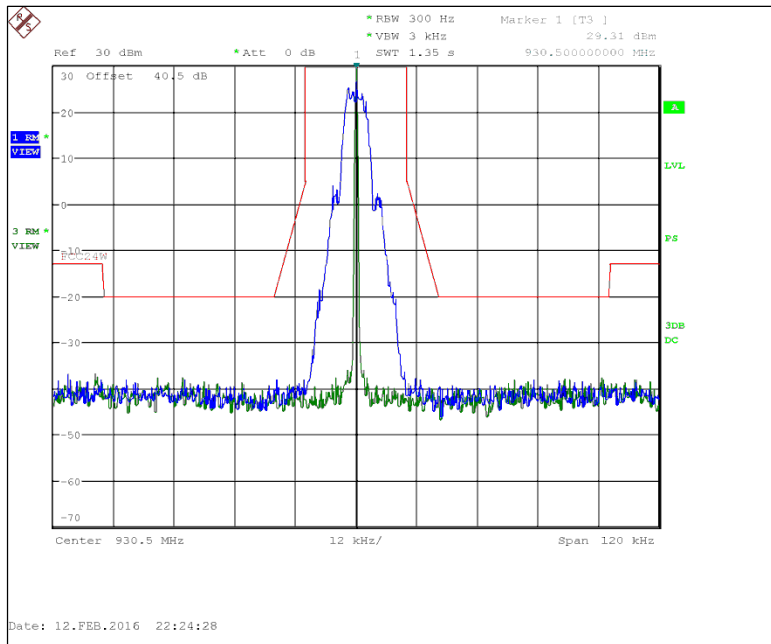

Figure 7.2.2-8: 930.5 MHz – 25 kHz Channel Spacing – mPass 5k Mode

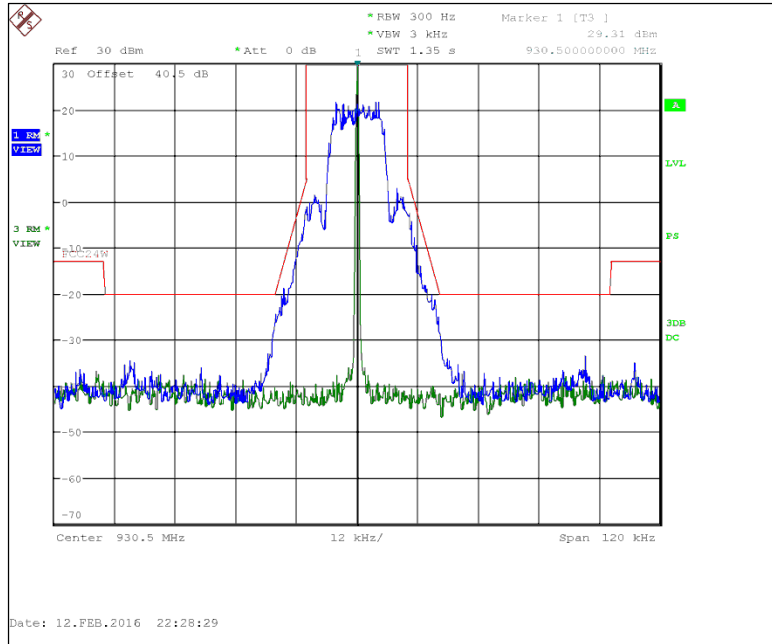

Figure 7.2.2-9: 930.5 MHz – 25 kHz Channel Spacing – mPass 10k Mode

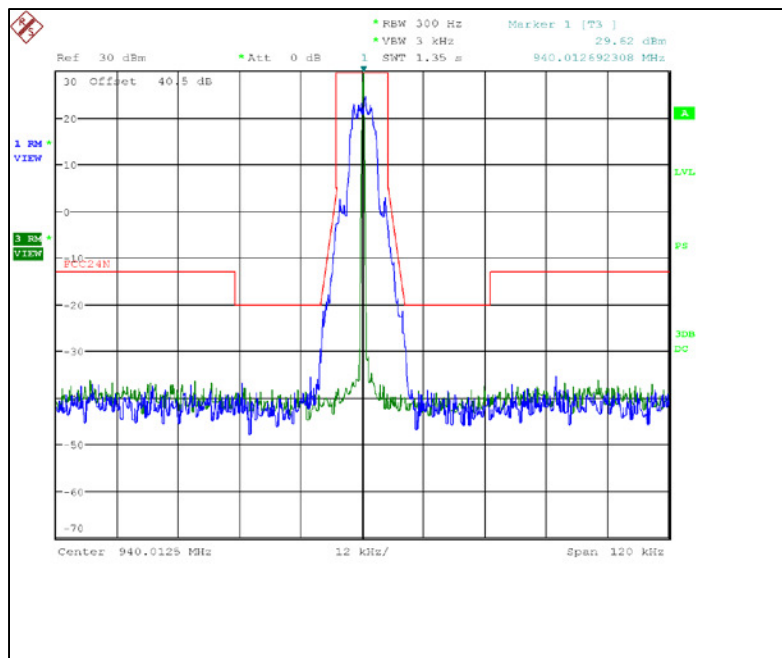

Figure 7.2.2-10: 940.0125 MHz – 12.5 kHz Channel Spacing – mPass 5k Mode

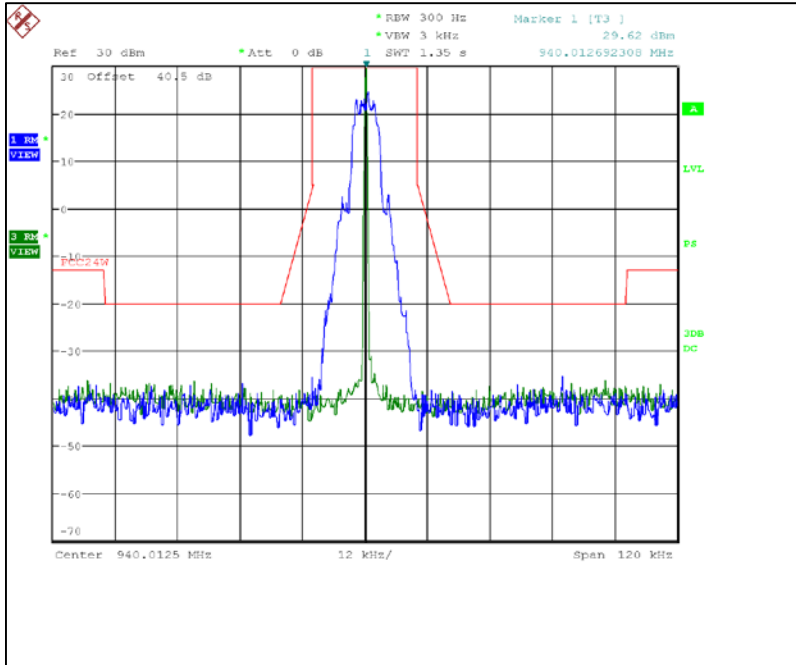

Figure 7.2.2-11: 940.0125 MHz – 25 kHz Channel Spacing – mPass 5k Mode

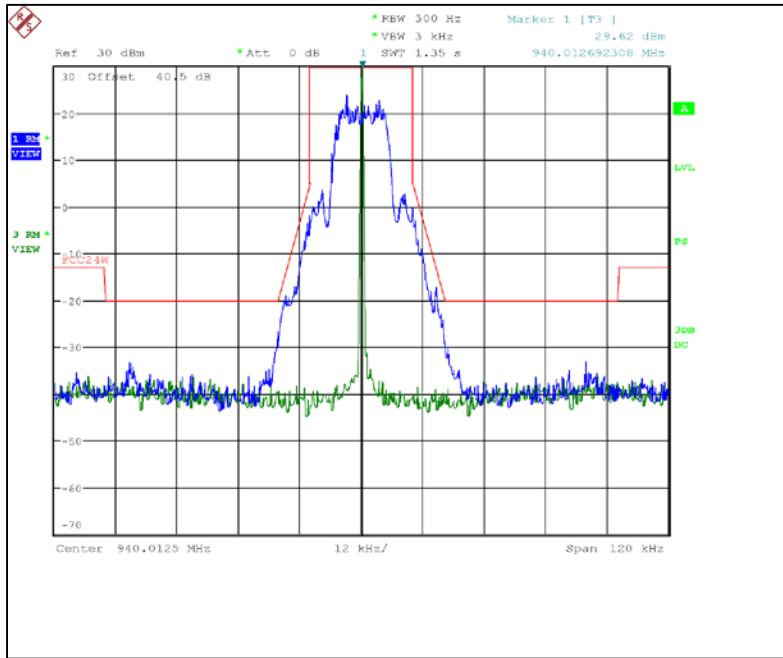

Figure 7.2.2-12: 940.0125 MHz – 25 kHz Channel Spacing – mPass 10k Mode

Part 101.111 a(6), RSS-119 5.8.6 (FCC Part 101.111a(6) provides worst case)

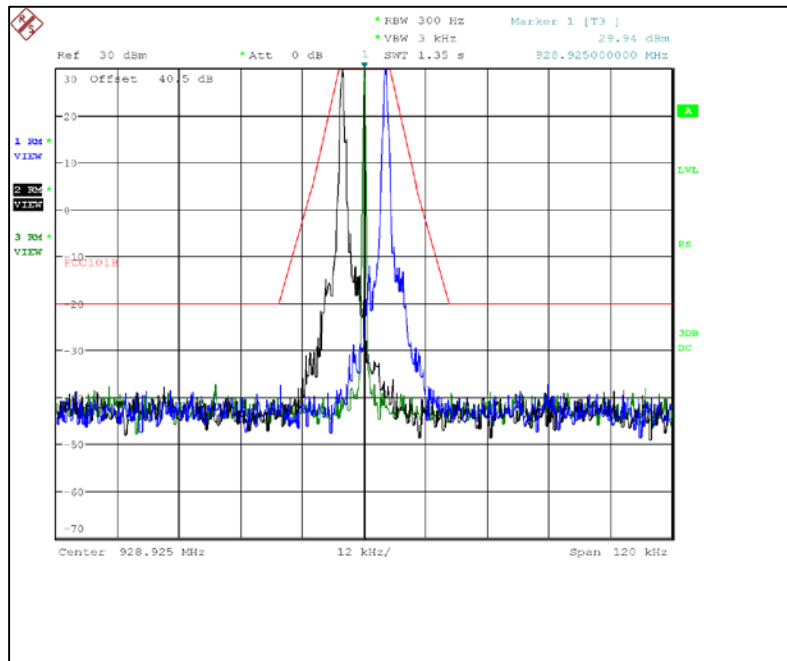

Figure 7.2.2-13: 928.925 MHz – Boost Mode

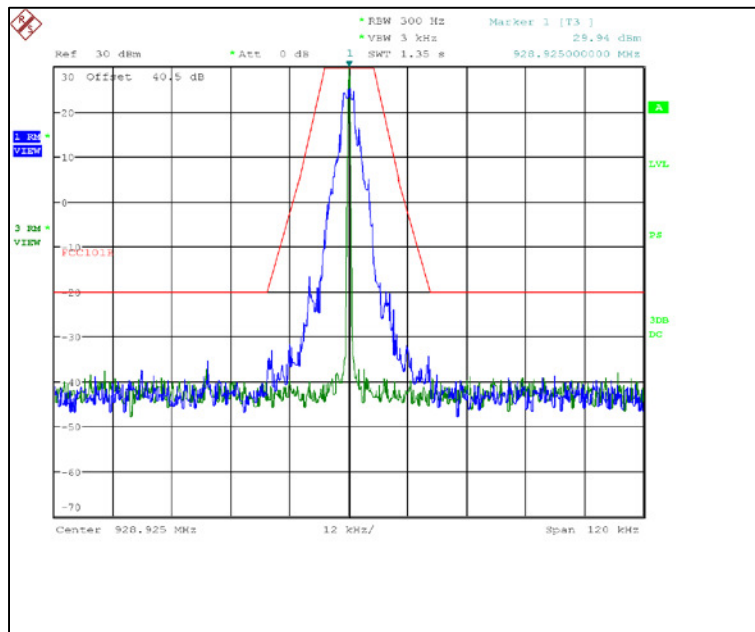

Figure 7.2.2-14: 928.925 MHz – C&I Mode

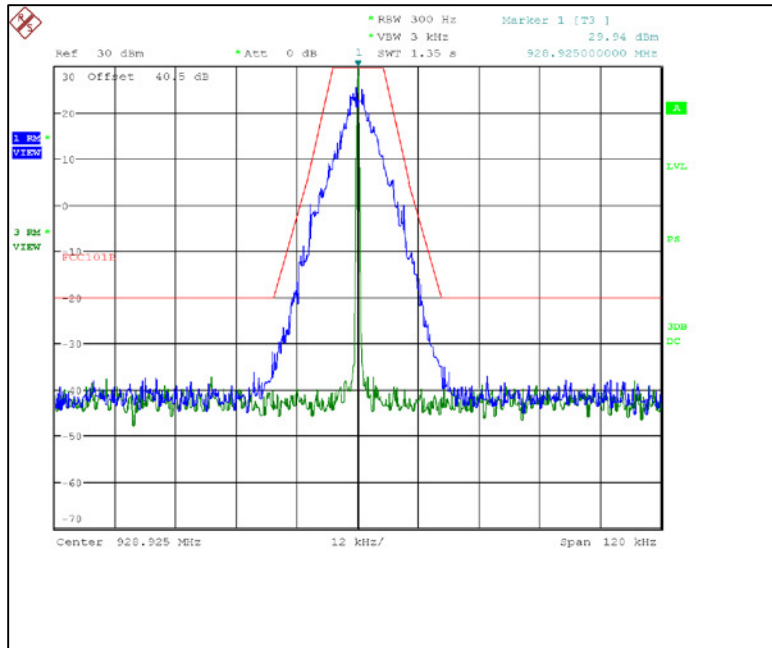

Figure 7.2.2-15: 928.925 MHz – Double Density Mode

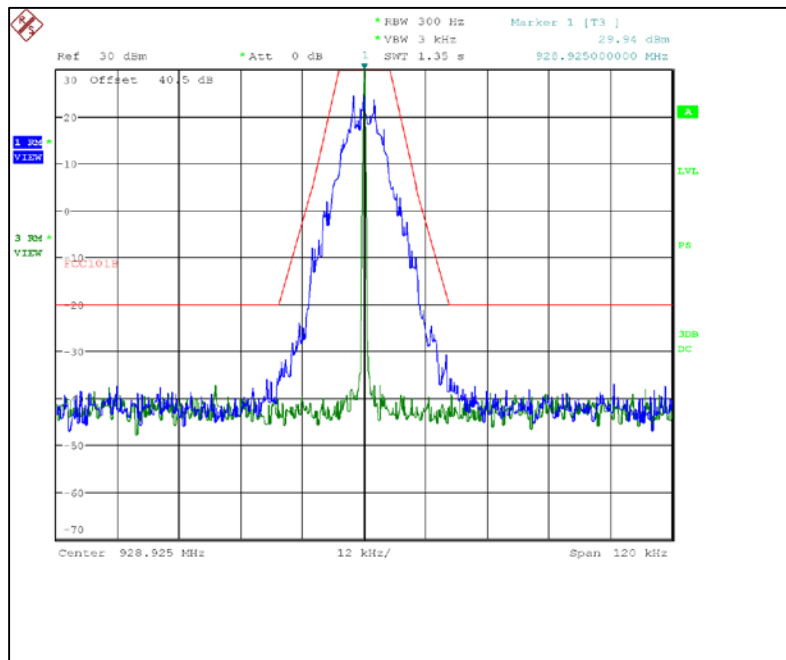

Figure 7.2.2-16: 928.925 MHz – Normal Mode

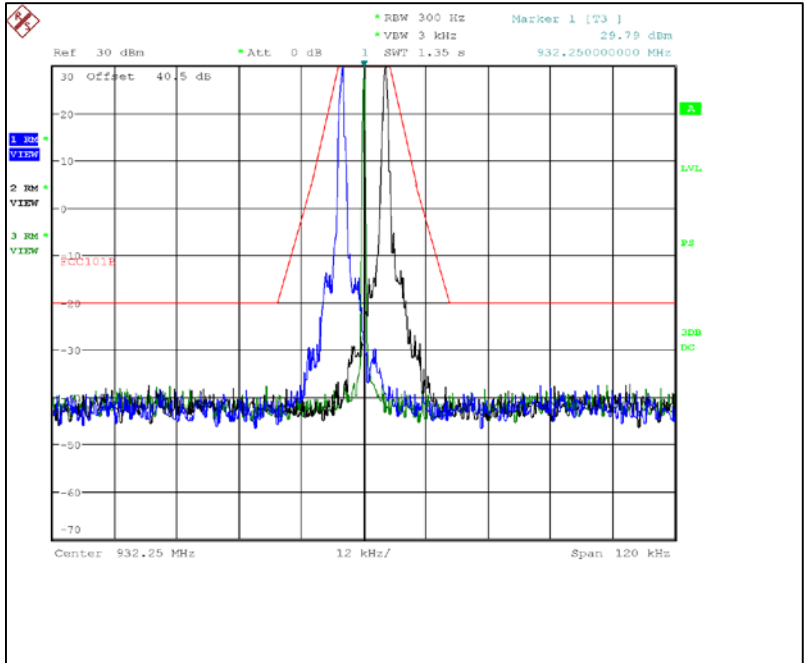

Figure 7.2.2-17: 932.25 MHz – Boost Mode

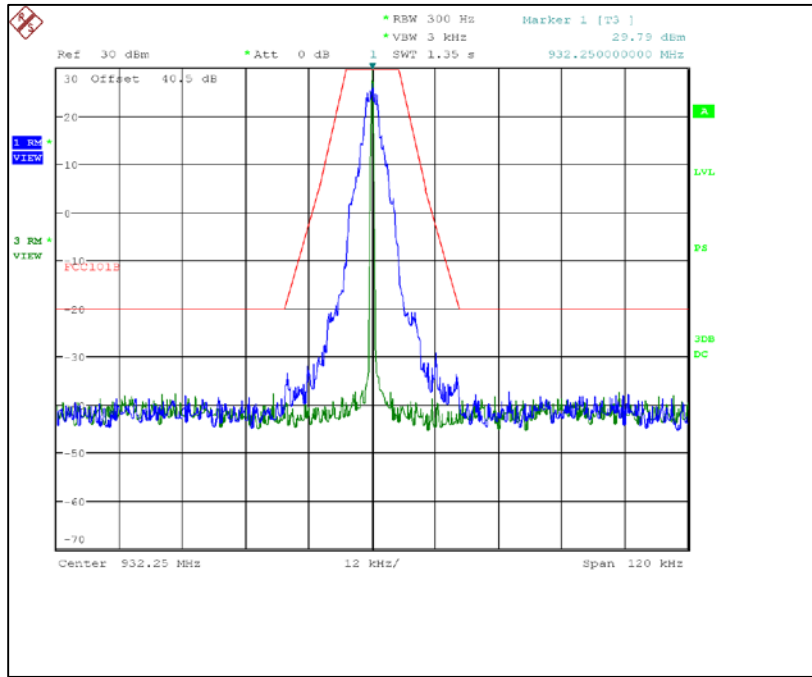

Figure 7.2.2-18: 932.25 MHz – C&I Mode

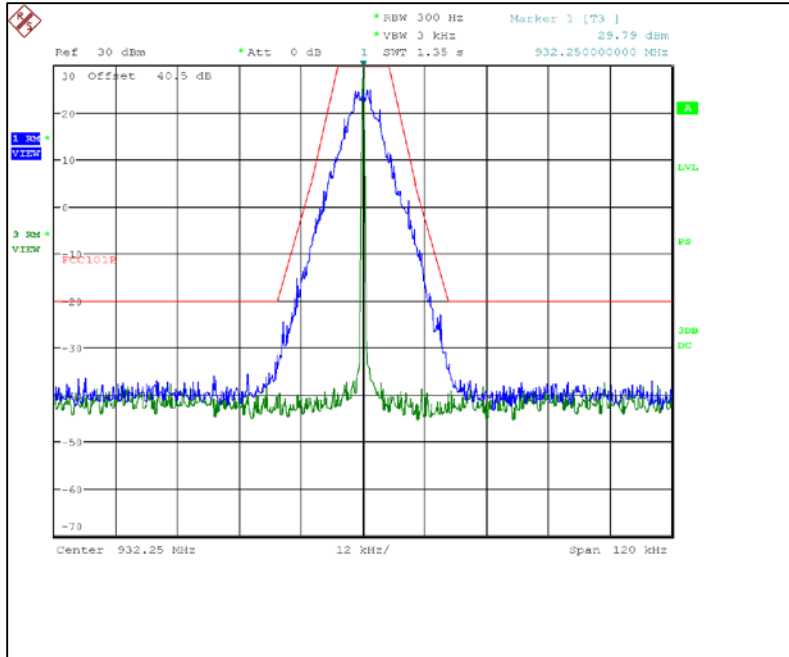

Figure 7.2.2-19: 932.25 MHz – Double Density Mode

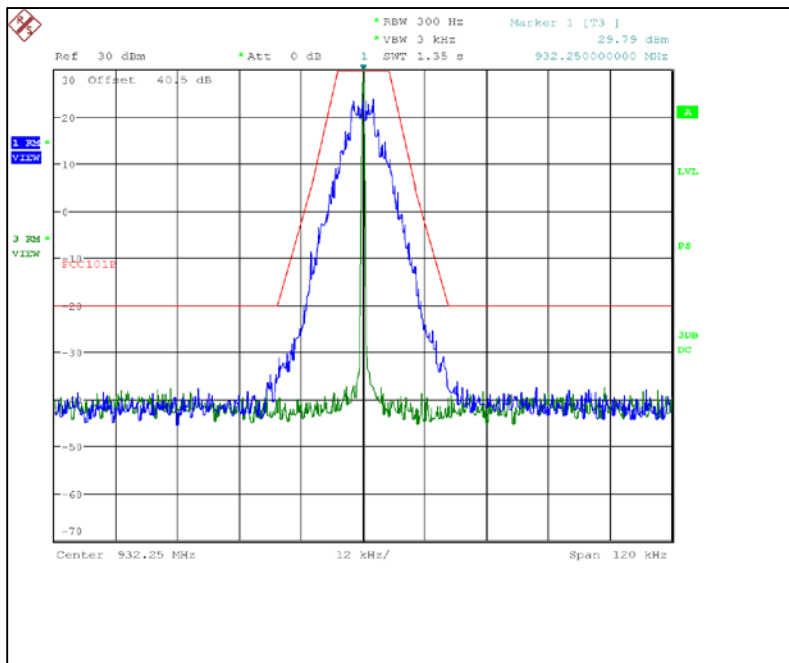

Figure 7.2.2-20: 932.25 MHz – Normal Mode

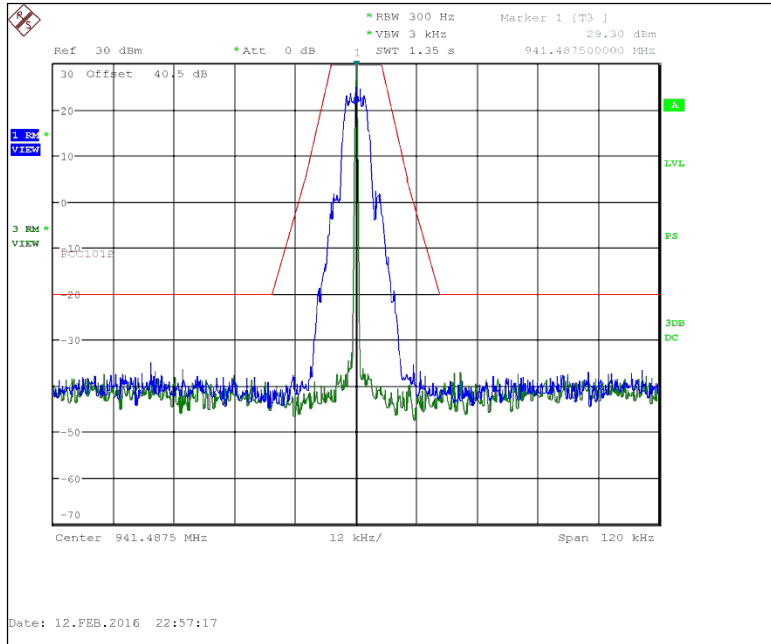

Figure 7.2.2-21: 941.4875 MHz – mPass 5k Mode

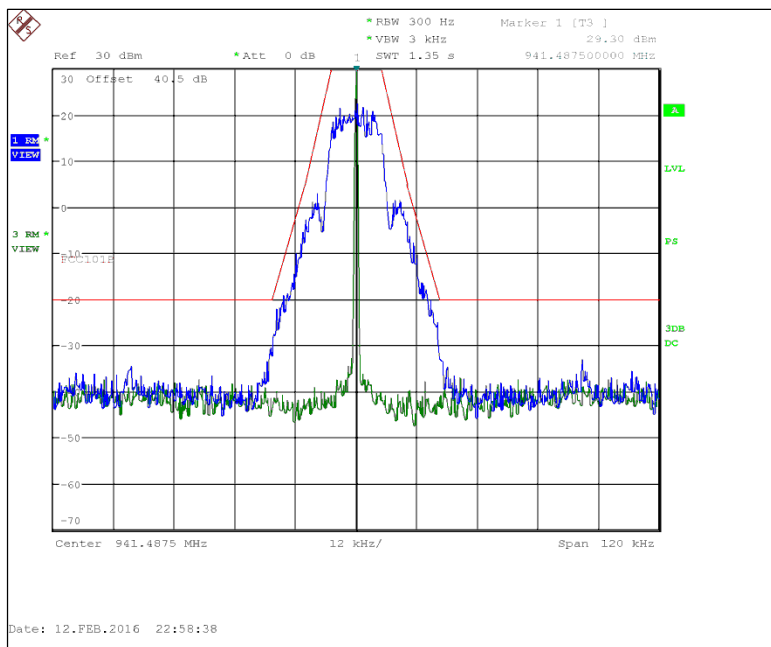

Figure 7.2.2-22: 941.4875 MHz – mPass 10k Mode

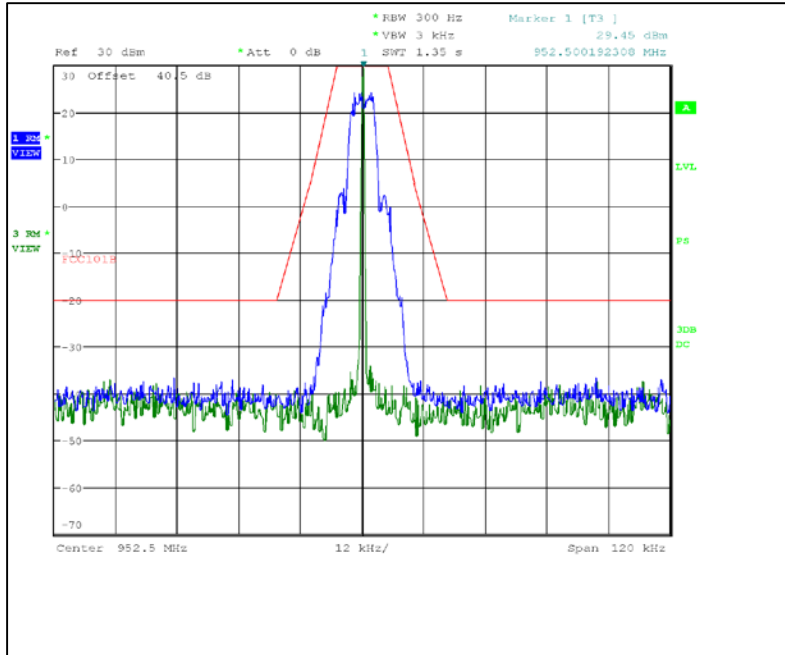

Figure 7.2.2-23: 952.5 MHz – mPass 5k Mode

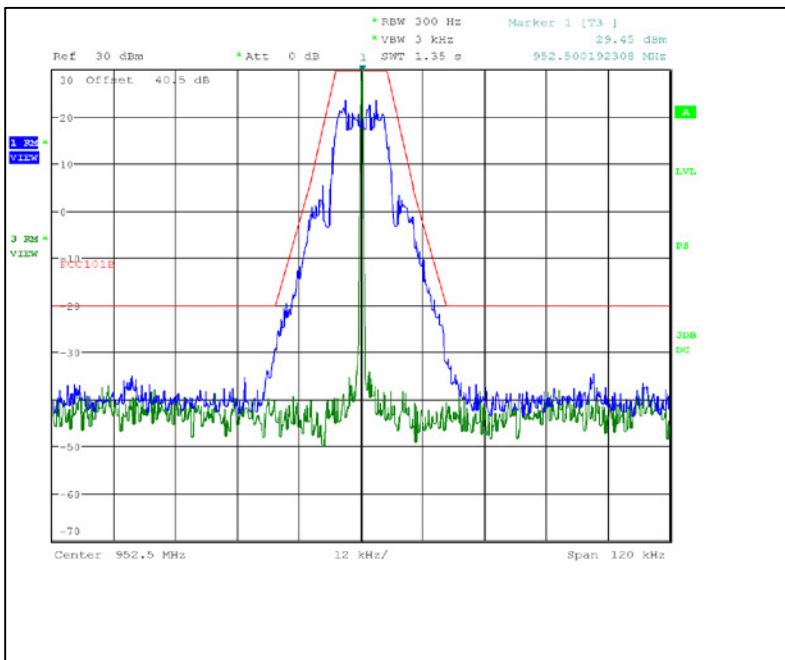

Figure 7.2.2-24: 952.5 MHz – mPass 10k Mode

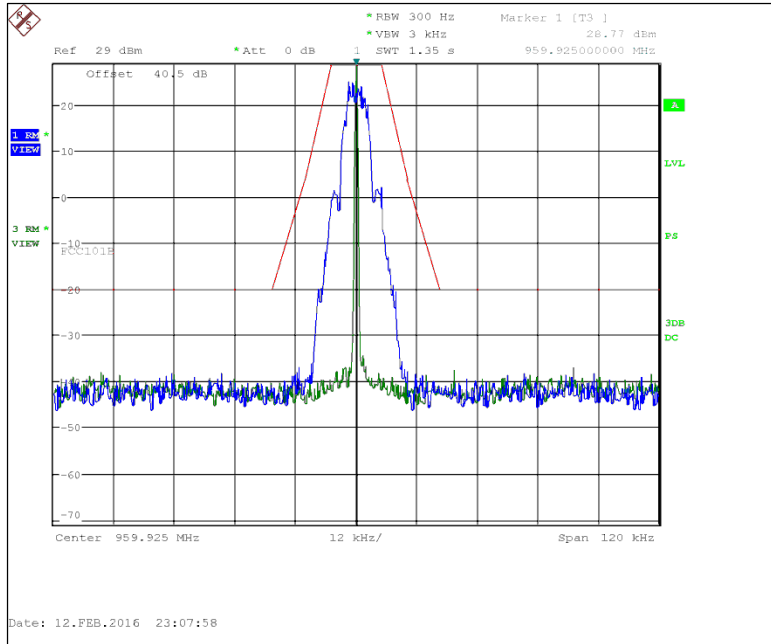

Figure 7.2.2-25: 959.925 MHz – mPass 5k Mode

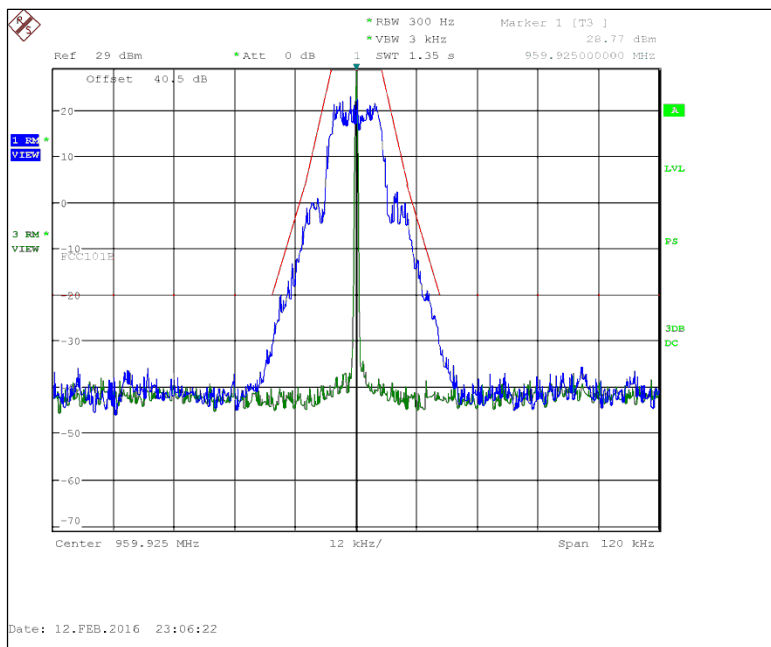

Figure 7.2.2-26: 959.925 MHz – mPass 10k Mode

7.2.3 Measurement Results – 99% Bandwidth

The bandwidth was measured in accordance with RSS-Gen 6.6. The occupied bandwidth measurement function of the spectrum analyzer was used to measure the 99% bandwidth. The span of the analyzer was set to capture all products of the modulation process, including the emission sidebands. The resolution bandwidth was set to 1% to 5% of the occupied bandwidth. The video bandwidth was set to 3 times the resolution bandwidth.

Frequency (MHz)	IC Rule Part	Mode of Operation	99% Bandwidth (kHz)
901.5000	RSS-134	Boost	1.250
901.5000	RSS-134	C&I	5.961
901.5000	RSS-134	Double Density	12.820
901.5000	RSS-134	Normal	11.138
930.5000	RSS-134	mPass 5k	5.769
930.5000	RSS-134	mPass 10k	11.939
940.0125	RSS-134	mPass 5k	5.865
940.0125	RSS-134	mPass 10k	11.939
928.9250	RSS-119	C&I	6.026
928.9250	RSS-119	Double Density	12.900
928.9250	RSS-119	Normal	11.298
928.9250	RSS-119	Boost	1.250
932.2500	RSS-119	C&I	5.961
932.2500	RSS-119	Double Density	12.500
932.2500	RSS-119	Normal	11.859
932.2500	RSS-119	Boost	1.250
941.4875	RSS-119	mPass 5k	5.801
941.4875	RSS-119	mPass 10k	11.939
952.5000	RSS-119	mPass 5k	5.769
952.5000	RSS-119	mPass 10k	11.779

IC RSS-GEN 6.6, IC RSS-134

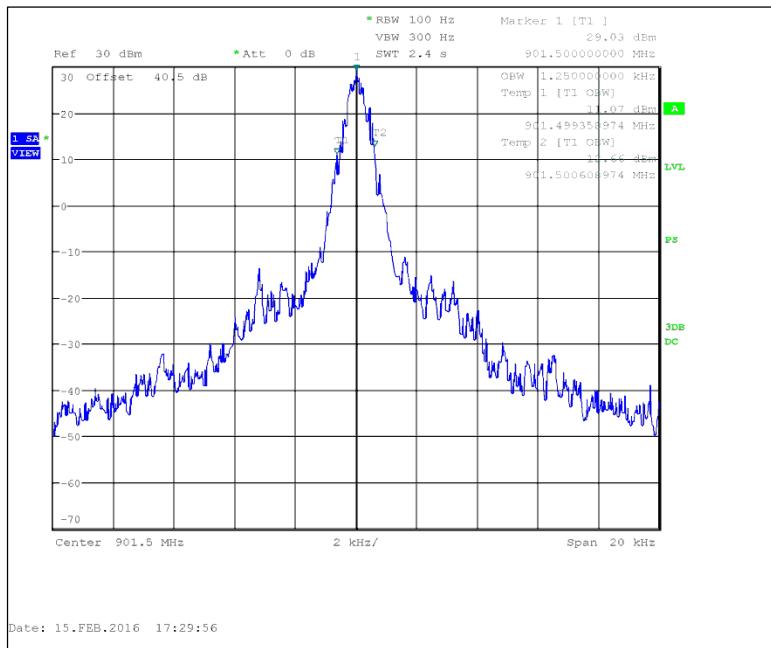

Figure 7.2.3-1: 901.5 MHz – Boost Mode

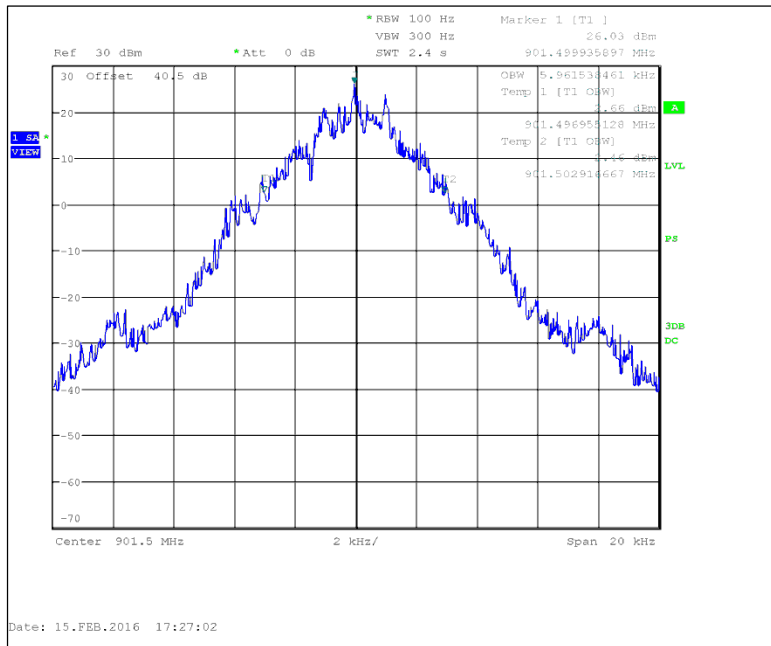

Figure 7.2.3-2: 901.5 MHz – C&I Mode

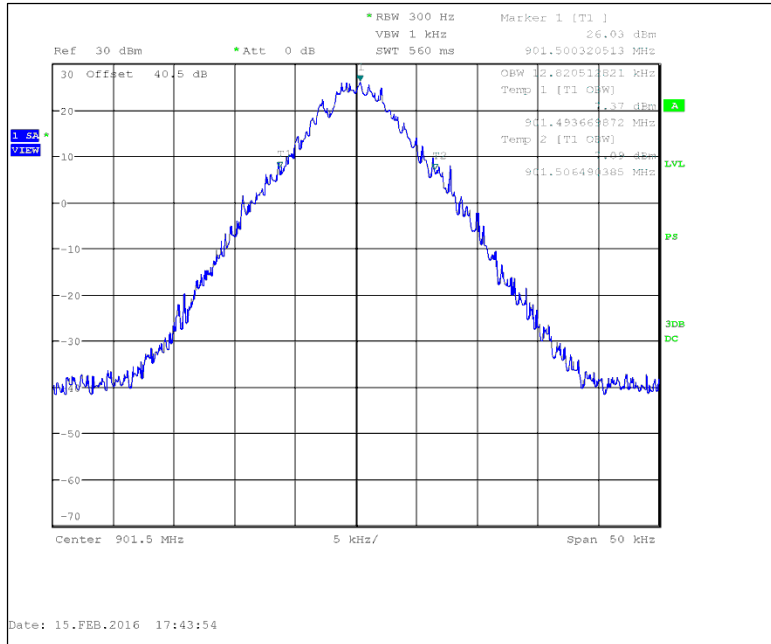

Figure 7.2.3-3: 901.5 MHz – Double Density Mode

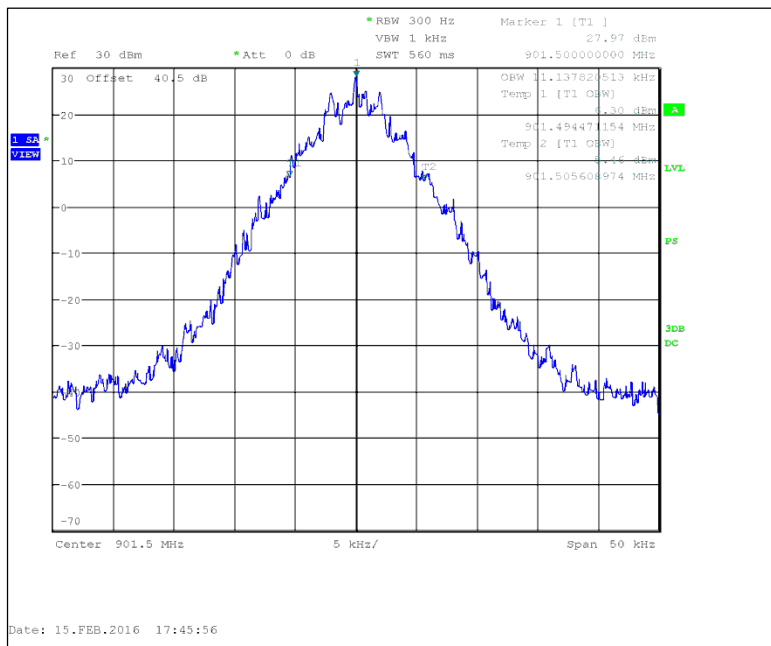

Figure 7.2.3-4: 901.5 MHz – Normal Mode

RSS-Gen 6.6, RSS-119

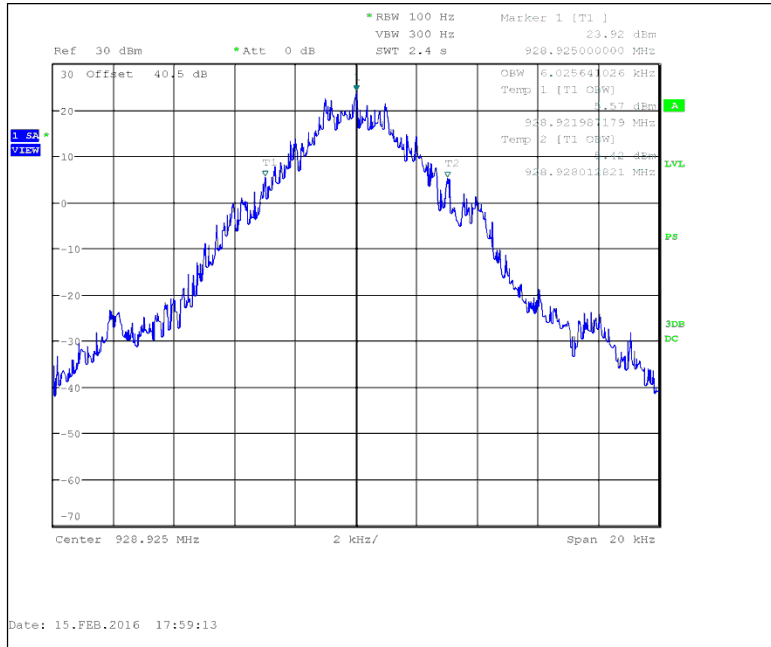

Figure 7.2.3-9: 928.925 MHz – C&I Mode

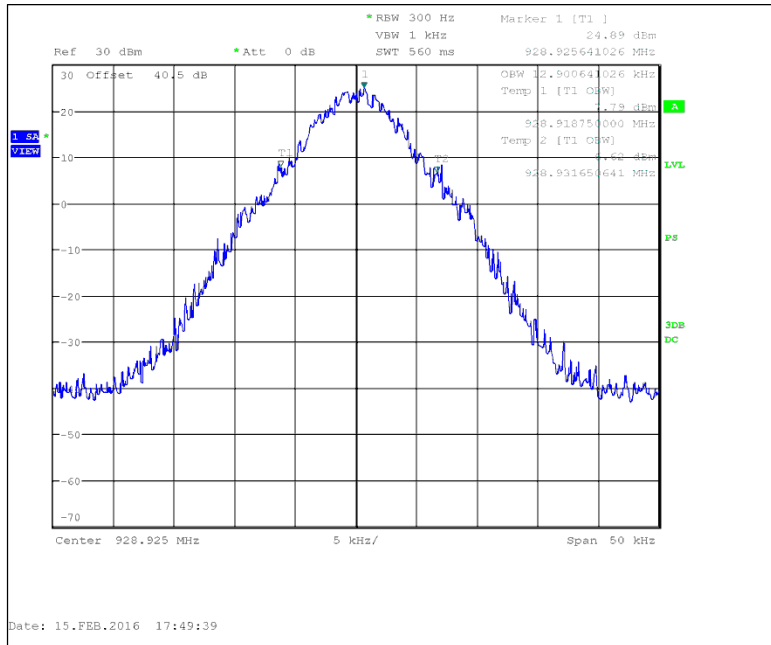

Figure 7.2.3-10: 928.925 MHz – Double Density Mode

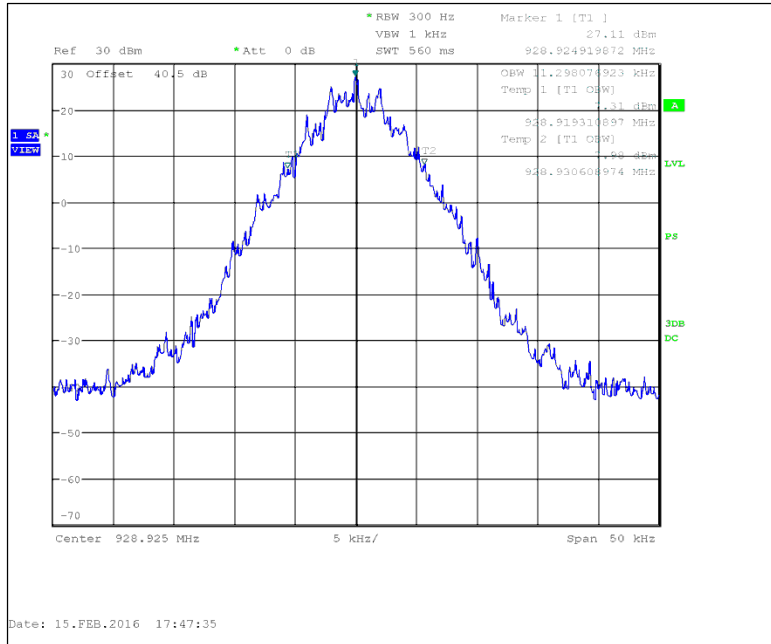

Figure 7.2.3-11: 928.925 MHz – Normal Mode

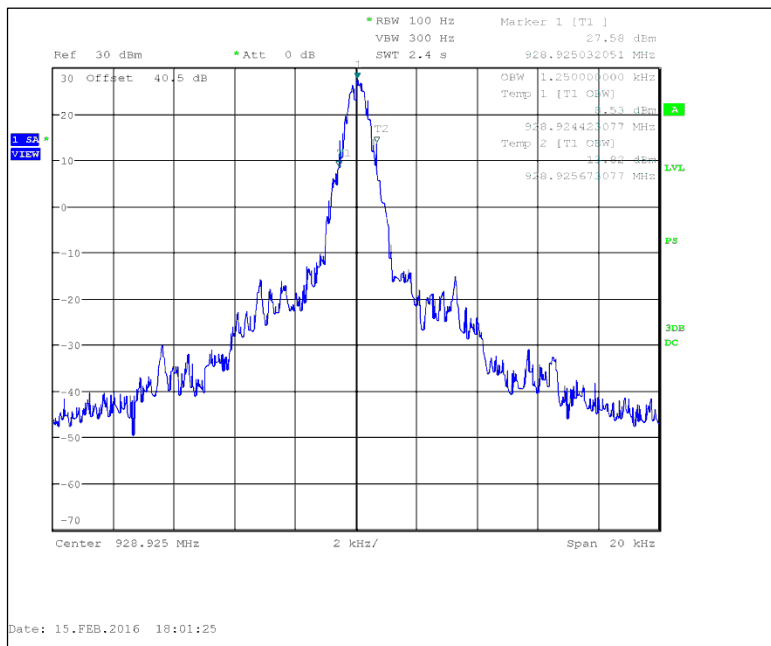

Figure 7.2.3-12: 928.925 MHz — Boost Mode

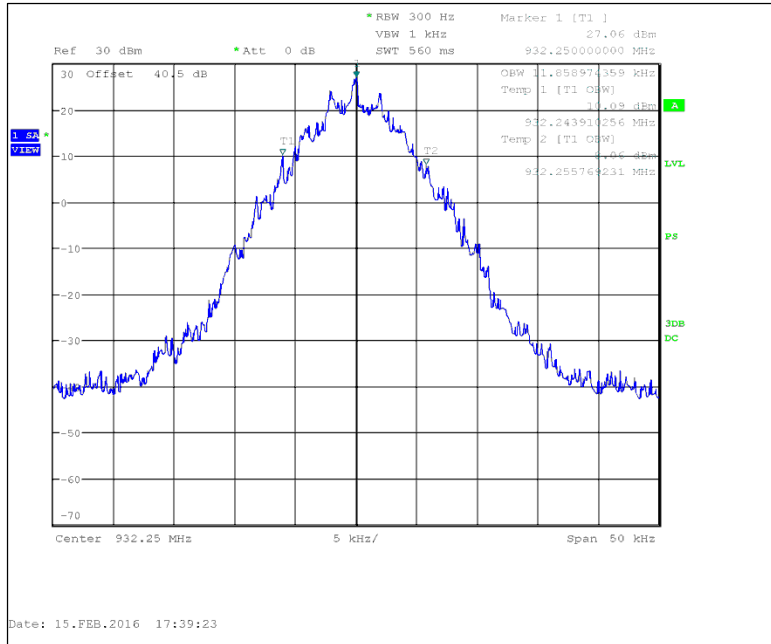

Figure 7.2.3-15: 932.25 MHz – Normal Mode

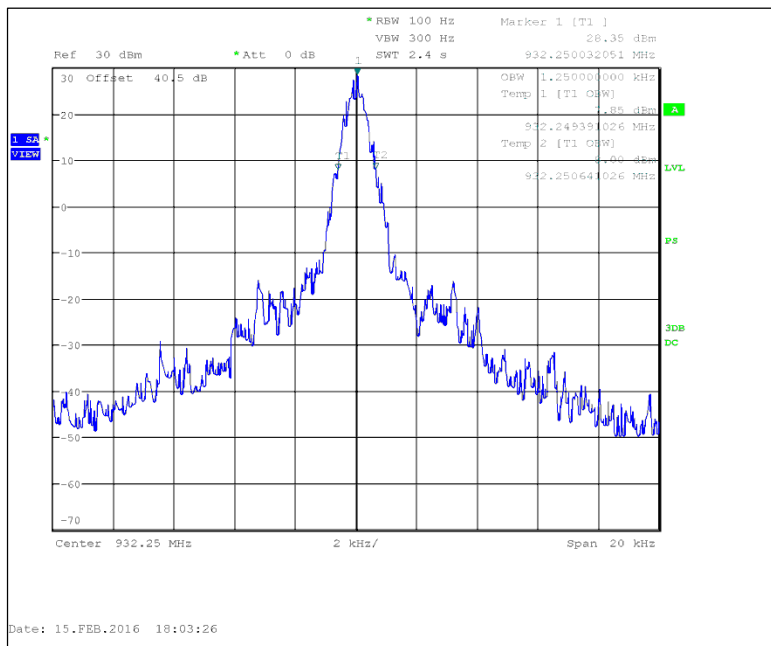

Figure 7.2.3-16: 932.25 MHz — Boost Mode

7.3 Spurious Emissions at Antenna Terminals

7.3.1 Measurement Procedure

The RF output of the equipment under test was directly connected to the input of the spectrum analyzer through 40.5 dB of passive attenuation. The spectrum analyzer resolution bandwidth was set to 100 kHz below 1000 MHz and 1 MHz above 1000 MHz. The internal correction factors of the spectrum analyzer were employed to correct for any cable, attenuator or filter losses. The spectrum was investigated in accordance to CFR 47 Part 2.1057. Results are shown below.

7.3.2 Measurement Results

Part 24.133 a(1), a(2), IC RSS-134 4.4.1, 4.4.2

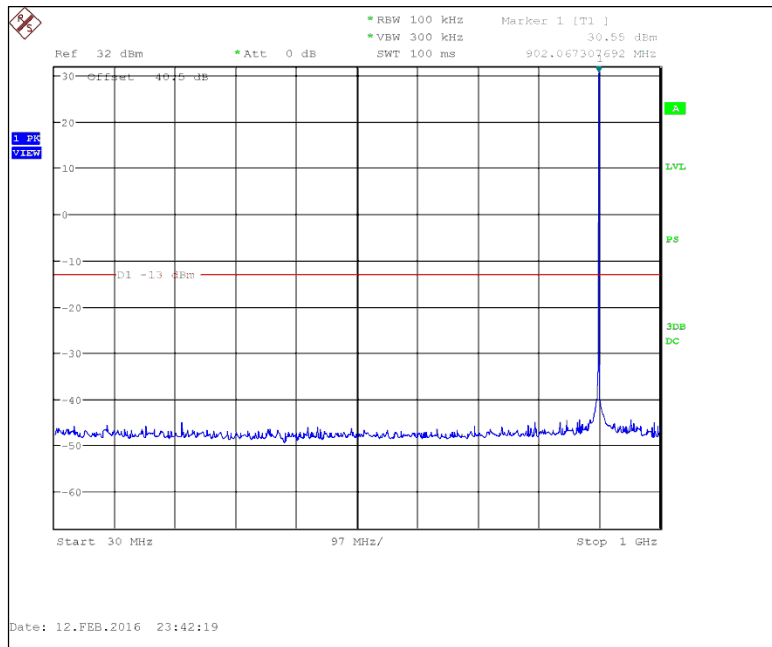

Figure 7.3.2-1: 901.5 MHz – 30MHz to 1GHz

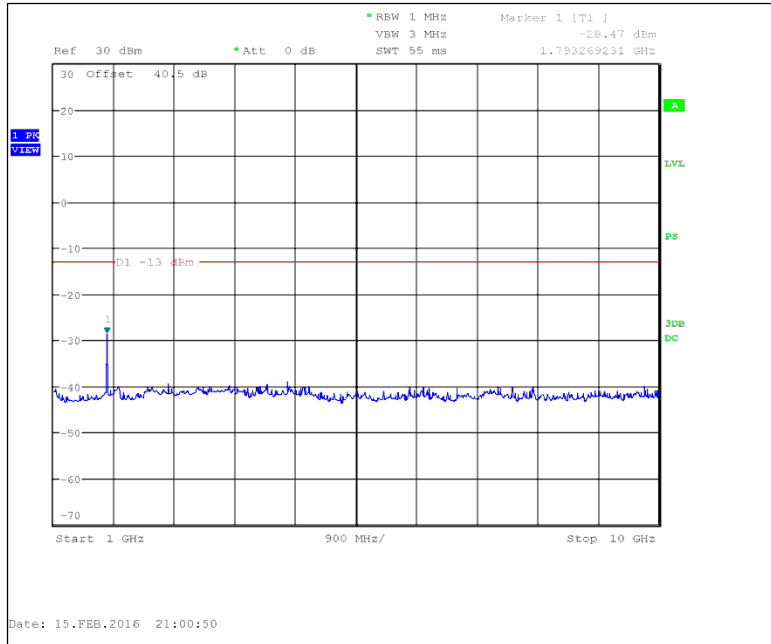

Figure 7.3.2-2: 901.5 MHz – 1GHz to 10GHz

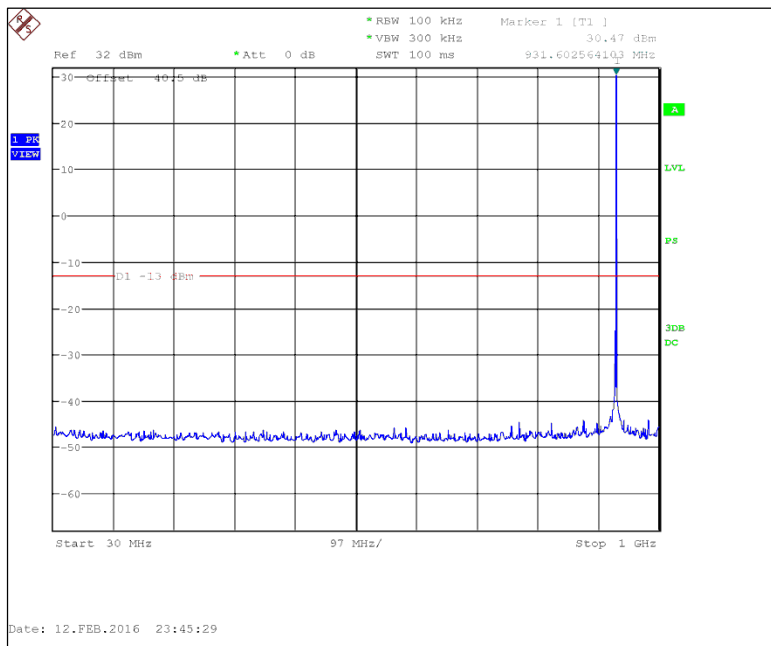

Figure 7.3.2-3: 930.5 MHz – 30MHz to 1GHz

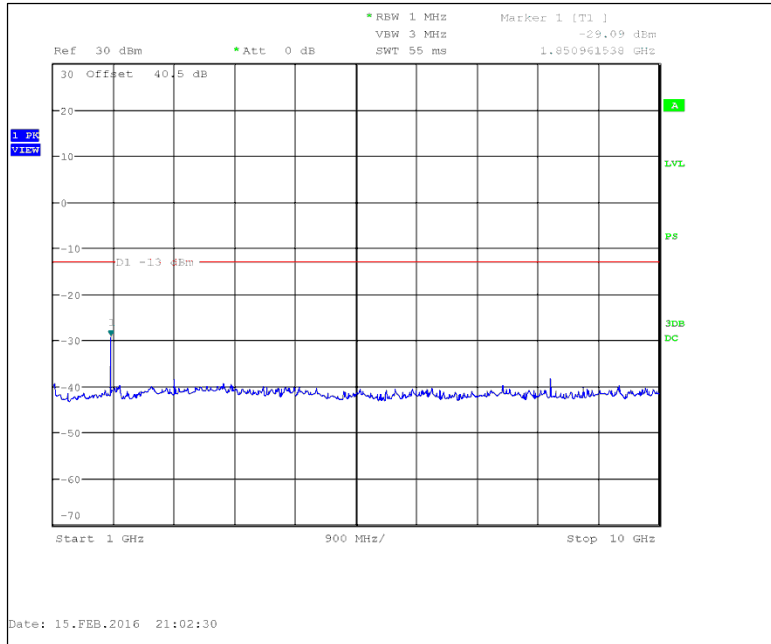

Figure 7.3.2-4: 930.5 MHz – 1GHz to 10GHz

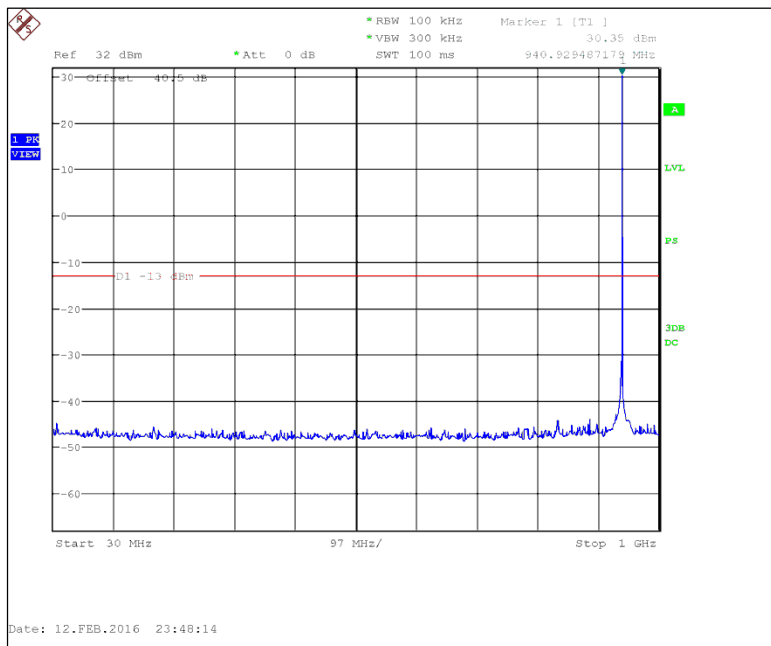

Figure 7.3.2-5: 940.0125 MHz – 30MHz to 1GHz

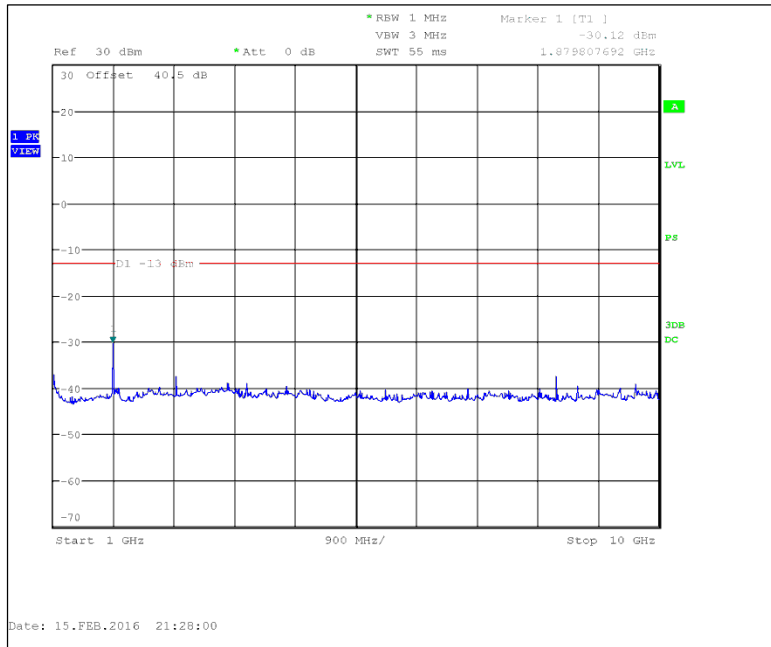

Figure 7.3.2-6: 940.0125 MHz – 1GHz to 10GHz

Part 101.111 a(6), RSS-119 5.8.6

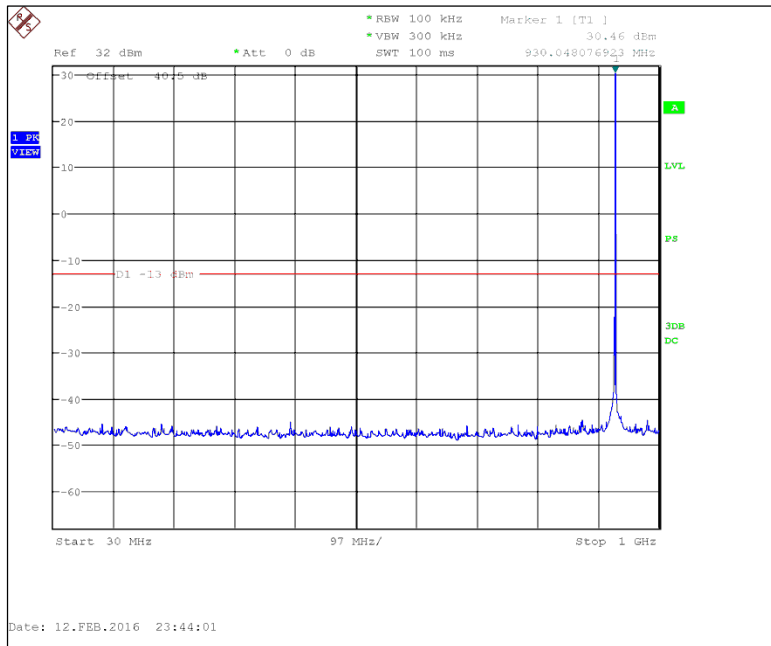

Figure 7.3.2-7: 928.925 MHz – 30MHz to 1GHz

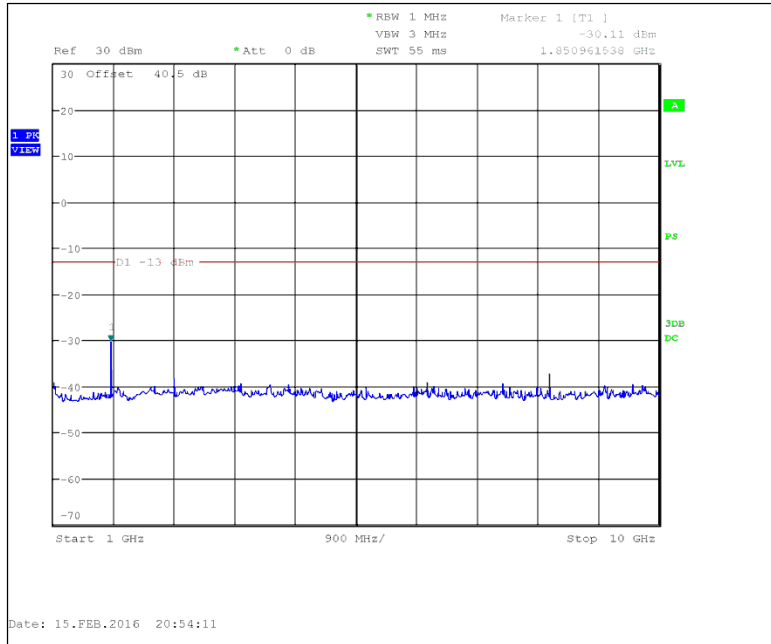

Figure 7.3.2-8: 928.925 MHz – 1GHz to 10GHz

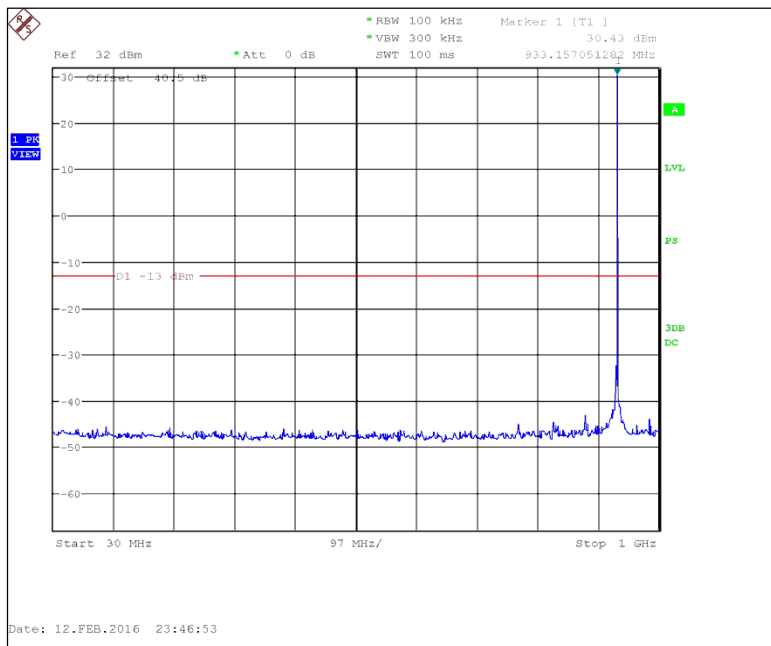

Figure 7.3.2-9: 932.25 MHz – 30MHz to 1GHz

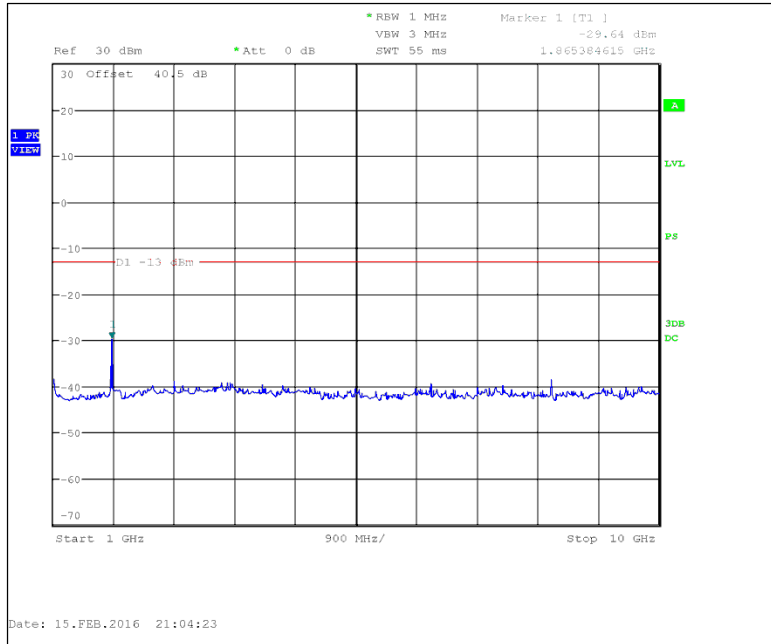

Figure 7.3.2-10: 932.25 MHz – 1GHz to 10GHz

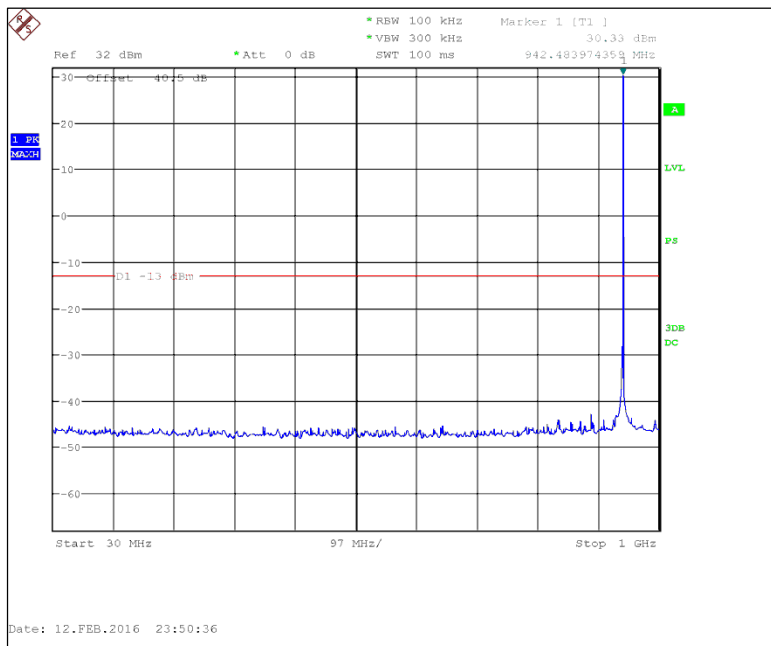

Figure 7.3.2-11: 941.4875 MHz – 30MHz to 1GHz

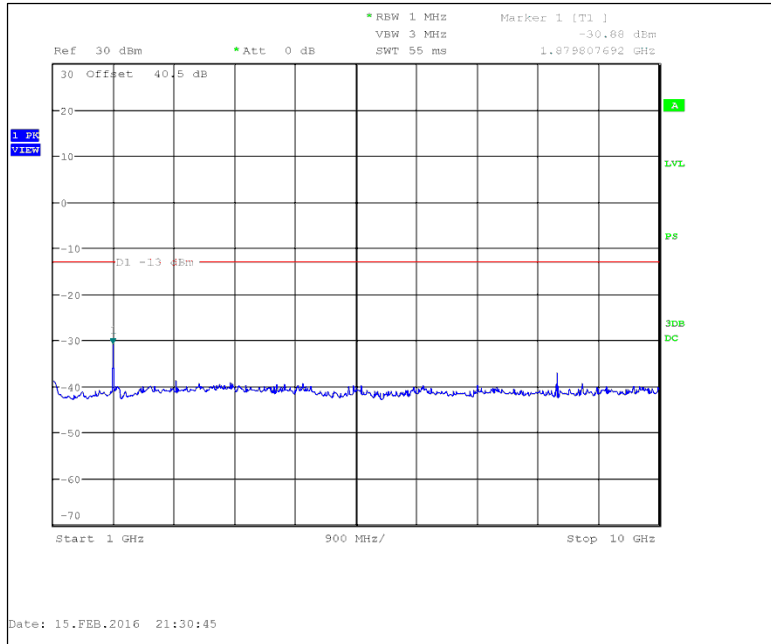

Figure 7.3.2-12: 941.4875 MHz – 1GHz to 10GHz

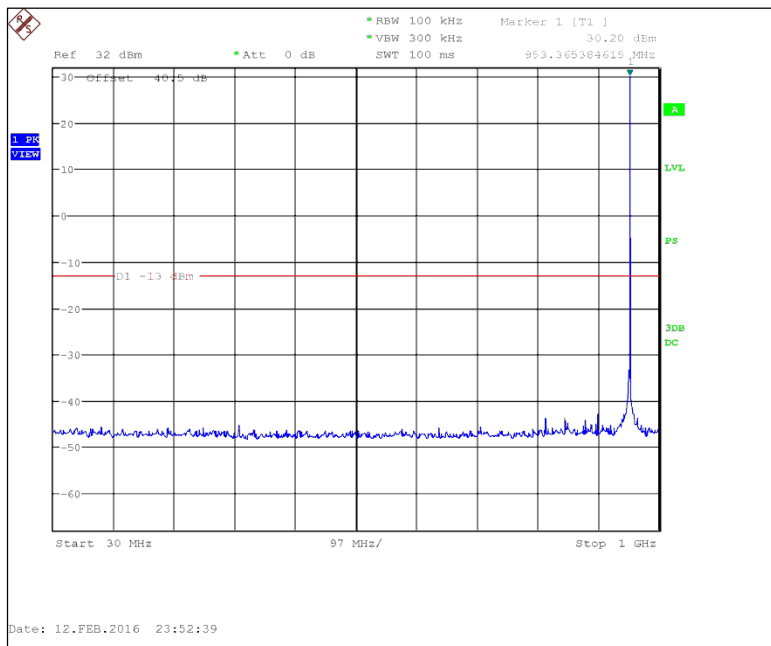

Figure 7.3.2-13: 952.5 MHz – 30MHz to 1GHz

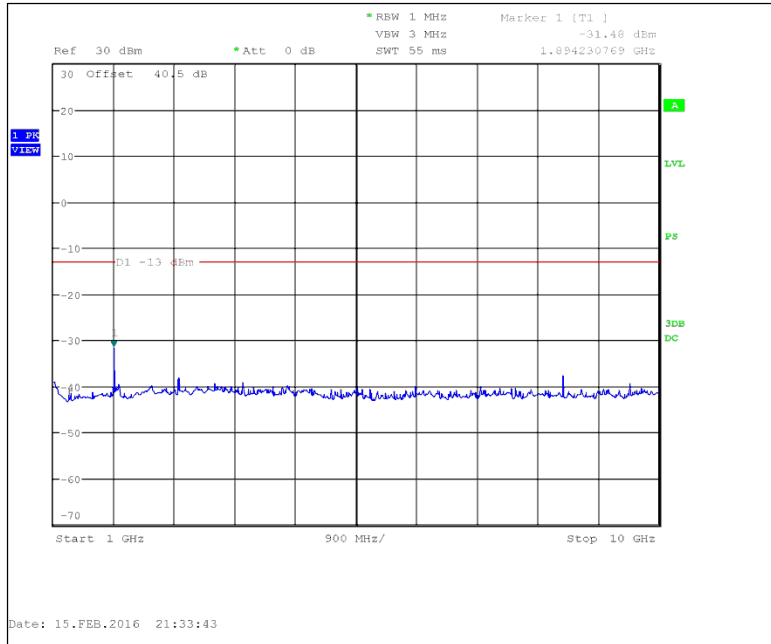

Figure 7.3.2-14: 952.5 MHz – 1GHz to 10GHz

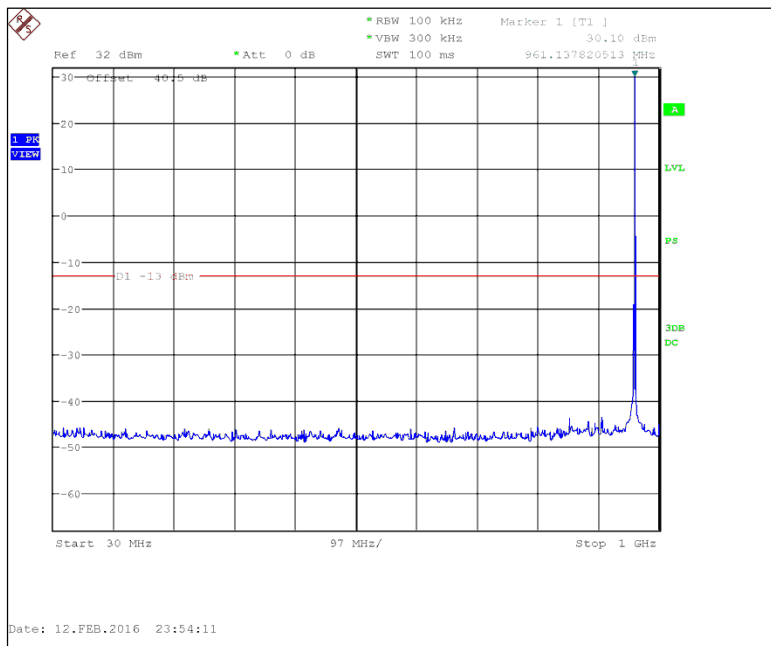

Figure 7.3.2-15: 959.925 MHz – 30MHz to 1GHz

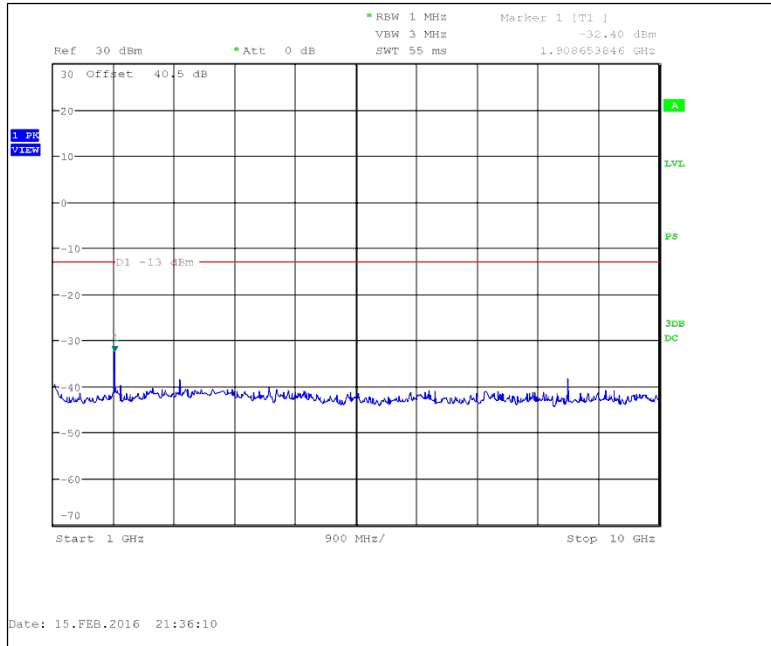

Figure 7.3.2-16: 959.925 MHz – 1GHz to 10GHz

7.4 Field Strength of Spurious Emissions

7.4.1 Measurement Procedure

The equipment under test is placed in the Semi-Anechoic Chamber (described in section 2.3.1) on a table at the turntable center. For each spurious emission, the antenna mast is raised and lowered from one (1) to four (4) meters and the turntable is rotated 360° and the maximum reading on the spectrum analyzer is recorded. This was repeated for both horizontal and vertical polarizations of the receive antenna.

The equipment under test is then replaced with a substitution antenna fed by a signal generator. The signal generator's frequency is set to that of the spurious emission recorded from the equipment under test. The antenna mast is raised and lowered from one (1) to four (4) meters to obtain a maximum reading on the spectrum analyzer. The output of the signal generator is then adjusted until the reading on the spectrum analyzer matches that obtained from the equipment under test. The signal generator level is recorded. The power in dBm of each spurious emission is calculated by correcting the signal generator level for the cable loss and gain of the substitution antenna referenced to a dipole. The spectrum was investigated in accordance to CFR 47 Part 2.1057.

The magnitude of all spurious emissions not reported were attenuated below the noise floor of the measurement system and therefore not specified in this report.

7.4.2 Measurement Results

Part 24.133 a(1), a(2), RSS-134 4.4.1, 4.4.2

Table 7.4.2-1: Field Strength of Spurious Emissions –901.5 MHz –Normal Mode

Frequency (MHz)	Spectrum Analyzer Level (dBm)	Antenna Polarity (H/V)	Spurious ERP (dBm)	Limit (dBm)	Margin (dB)
2704.5	-40.9	H	-33.26	-13.00	20.26
2704.5	-41.7	V	-33.66	-13.00	20.66
3606	-57.9	H	-48.52	-13.00	35.52
3606	-52.7	V	-44.52	-13.00	31.52
4507.5	-48.5	H	-37.30	-13.00	24.30
6310.5	-57.3	H	-39.30	-13.00	26.30

NOTE: All frequencies not listed were below the noise floor of the spectrum analyzer.

Table 7.4.2-2: Field Strength of Spurious Emissions –930.5 MHz – mPass 5k Mode

Frequency (MHz)	Spectrum Analyzer Level (dB μ V/m)	Antenna Polarity (H/V)	Spurious ERP (dBm)	Limit (dBm)	Margin (dB)
2791.5	64.3	H	-36.65	-13.00	23.65
2791.5	68.6	V	-31.85	-13.00	18.85
3722	50.8	H	-44.52	-13.00	31.52
3722	48.5	V	-48.12	-13.00	35.12
4652.5	58.5	H	-34.94	-13.00	21.94
4652.5	60.5	V	-35.34	-13.00	22.34
6513.5	55.2	H	-24.06	-13.00	11.06
6513.5	55.5	V	-37.76	-13.00	24.76

NOTE: All frequencies not listed were below the noise floor of the spectrum analyzer.

Table 7.4.2-3: Field Strength of Spurious Emissions –940.0125 MHz – mPass 5k Mode

Frequency (MHz)	Spectrum Analyzer Level (dB μ V/m)	Antenna Polarity (H/V)	Spurious ERP (dBm)	Limit (dBm)	Margin (dB)
2820.0375	65.3	H	-32.84	-13.00	19.84
2820.0375	68.7	V	-30.74	-13.00	17.74
4700.0625	60	H	-32.41	-13.00	19.41
4700.0625	61.5	V	-33.61	-13.00	20.61
6580.0875	50.5	H	-40.00	-13.00	27.00
6580.0875	58.1	V	-33.80	-13.00	20.80

NOTE: All frequencies not listed were below the noise floor of the spectrum analyzer.

Part 101.111 a(6), RSS-119 5.8.6**Table 7.4.2-4: Field Strength of Spurious Emissions –928.925 MHz –Normal Mode**

Frequency (MHz)	Spectrum Analyzer Level (dB μ V/m)	Antenna Polarity (H/V)	Spurious ERP (dBm)	Limit (dBm)	Margin (dB)
2786.775	63.9	H	-31.86	-13.00	18.86
2786.775	68.7	V	-28.46	-13.00	15.46
4644.625	57.2	H	-35.22	-13.00	22.22
4644.625	57.1	V	-37.02	-13.00	24.02
6502.475	50.5	H	-39.35	-13.00	26.35
6502.475	54.4	V	-37.35	-13.00	24.35

NOTE: All frequencies not listed were below the noise floor of the spectrum analyzer.

Table 7.4.2-5: Field Strength of Spurious Emissions – 932.25 MHz –Normal Mode

Frequency (MHz)	Spectrum Analyzer Level (dB μ V/m)	Antenna Polarity (H/V)	Spurious ERP (dBm)	Limit (dBm)	Margin (dB)
2796.75	65.6	H	-30.25	-13.00	17.25
2796.75	66.8	V	-33.25	-13.00	20.25
4661.25	59.8	H	-31.35	-13.00	18.35
4661.25	62	V	-34.25	-13.00	21.25
6525.75	51.7	H	-38.17	-13.00	25.17
6525.75	57.1	V	-36.07	-13.00	23.07

NOTE: All frequencies not listed were below the noise floor of the spectrum analyzer.

Table 7.4.2-6: Field Strength of Spurious Emissions –941.4875 MHz – mPass 5k Mode

Frequency (MHz)	Spectrum Analyzer Level (dB μ V/m)	Antenna Polarity (H/V)	Spurious ERP (dBm)	Limit (dBm)	Margin (dB)
2824.4625	65.0	H	-32.73	-13.00	19.73
2824.4625	67.3	V	-32.53	-13.00	19.53
4707.4375	58.9	H	-32.42	-13.00	19.42
4707.4375	59.4	V	-34.72	-13.00	21.72
6590.4125	52.5	H	-38.31	-13.00	25.31
6590.4125	57.3	V	-35.11	-13.00	22.11

NOTE: All frequencies not listed were below the noise floor of the spectrum analyzer.

Table 7.4.2-7: Field Strength of Spurious Emissions –952.5 MHz – mPass 5k Mode

Frequency (MHz)	Spectrum Analyzer Level (dB μ V/m)	Antenna Polarity (H/V)	Spurious ERP (dBm)	Limit (dBm)	Margin (dB)
2857.5	64.7	H	-32.02	-13.00	19.02
2857.5	67.8	V	-32.42	-13.00	19.42
4762.5	55.4	H	-35.51	-13.00	22.51
4762.5	57.8	V	-38.01	-13.00	25.01
6667.5	54.3	H	-34.75	-13.00	21.75
6667.5	58	V	-34.85	-13.00	21.85

NOTE: All frequencies not listed were below the noise floor of the spectrum analyzer.

Table 7.4.2-8: Field Strength of Spurious Emissions –959.925 MHz – mPass 5k Mode

Frequency (MHz)	Spectrum Analyzer Level (dB μ V/m)	Antenna Polarity (H/V)	Spurious ERP (dBm)	Limit (dBm)	Margin (dB)
2879.775	65.6	H	-31.50	-13.00	18.50
2879.775	67.4	V	-32.50	-13.00	19.50
4799.625	54.3	H	-38.77	-13.00	25.77
4799.625	58.7	V	-36.57	-13.00	23.57
6719.475	52.8	H	-35.68	-13.00	22.68
6719.475	56.6	V	-34.58	-13.00	21.58

NOTE: All frequencies not listed were below the noise floor of the spectrum analyzer.

7.5 Frequency Stability

7.5.1 Measurement Procedure

The equipment under test is placed inside an environmental chamber. The RF output is directly coupled through appropriate attenuation to the input of the measurement equipment. A power supply is attached to the primary supply voltage.

Frequency measurements were made at intervals of 10° C over the temperature range of -30° C to +50° C at the normal supply voltage. A period of time sufficient to stabilize all components of the equipment was allowed at each temperature step. The equipment operates at 3.6 Vdc. At 20°C two additional measurements were performed at +/- 15% of 3.6Vdc. The maximum variation of frequency over temperature and voltage was recorded.

The transceiver as tested incorporates a TCXO made by KDS.

The results of the test are shown below:

7.5.2 Measurement Results

Part 24.135, RSS-134 (4.5)

Frequency Stability

Frequency (MHz): 901.5
 Deviation Limit (PPM): 1.0ppm

Temperature C	Frequency MHz	Frequency Error (PPM)	Voltage (%)	Voltage (VDC)
-30 C	901.500150	0.166	100%	3.60
-20 C	901.500087	0.097	100%	3.60
-10 C	901.499987	-0.014	100%	3.60
0 C	901.500104	0.115	100%	3.60
10 C	901.500115	0.128	100%	3.60
20 C	901.499962	-0.042	100%	3.60
30 C	901.499937	-0.070	100%	3.60
40 C	901.499975	-0.028	100%	3.60
50 C	901.500012	0.013	100%	3.60
20 C	901.499978	-0.024	85%	3.06
20 C	901.499970	-0.033	115%	4.14

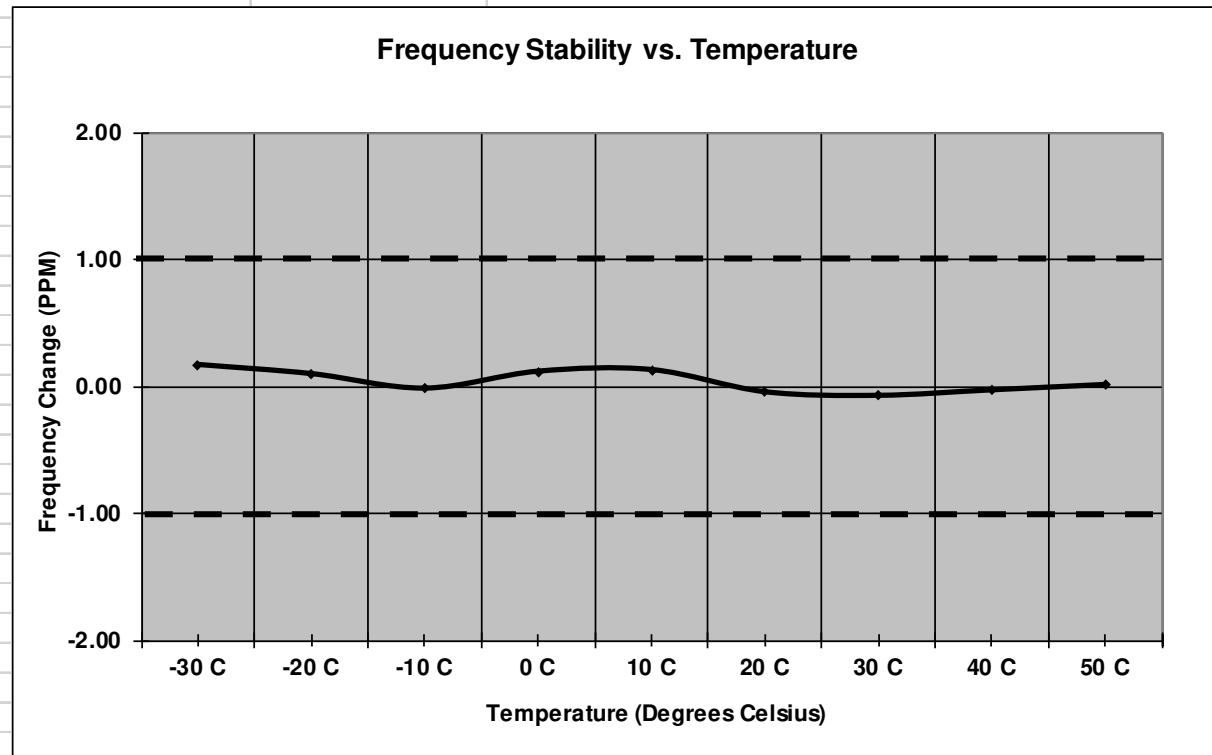

Figure 7.5.2-1: Frequency Stability –901.5 MHz

Part 24.135, RSS-134 (4.5)

Frequency Stability

Frequency (MHz): 930.5

Deviation Limit (PPM): 1.0ppm

Temperature C	Frequency MHz	Frequency Error (PPM)	Voltage (%)	Voltage (VDC)
-30 C	930.500025	0.027	100%	3.60
-20 C	930.500090	0.097	100%	3.60
-10 C	930.499950	-0.054	100%	3.60
0 C	930.500050	0.054	100%	3.60
10 C	930.500160	0.172	100%	3.60
20 C	930.500000	0.000	100%	3.60
30 C	930.499950	-0.054	100%	3.60
40 C	930.500020	0.021	100%	3.60
50 C	930.500040	0.043	100%	3.60
20 C	930.500001	0.001	85%	3.06
20 C	930.500000	0.000	115%	4.14

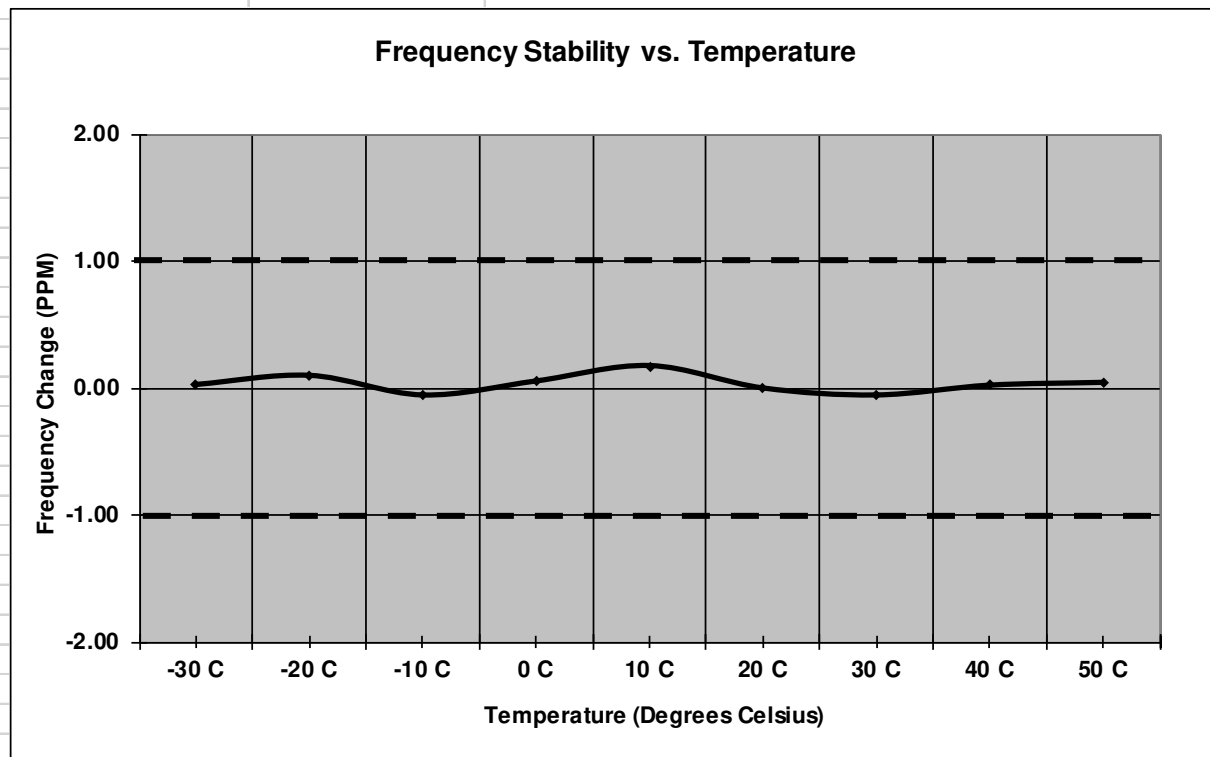

Figure 7.5.2-2: Frequency Stability –930.5 MHz

Part 101.107, RSS-119 5.3

Frequency Stability

Frequency (MHz): 959.925

Deviation Limit (PPM): 1.0ppm

Temperature C	Frequency MHz	Frequency Error (PPM)	Voltage (%)	Voltage (VDC)
-30 C	959.925090	0.094	100%	3.60
-20 C	959.925075	0.078	100%	3.60
-10 C	959.924924	-0.079	100%	3.60
0 C	959.925000	0.000	100%	3.60
10 C	959.925109	0.114	100%	3.60
20 C	959.924985	-0.016	100%	3.60
30 C	959.924940	-0.063	100%	3.60
40 C	959.924953	-0.049	100%	3.60
50 C	959.925050	0.052	100%	3.60
20 C	959.924984	-0.017	85%	3.06
20 C	959.924986	-0.015	115%	4.14

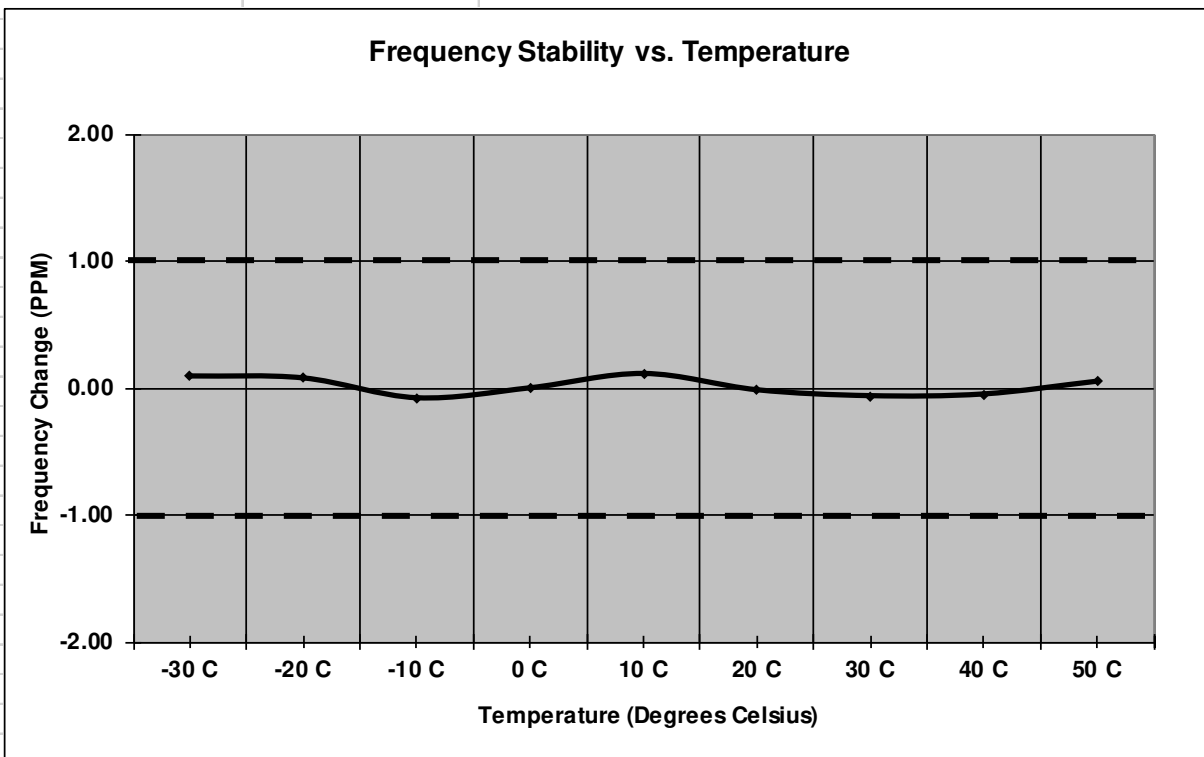

Figure 7.5.2-3: Frequency Stability –959.925 MHz

8.0 CONCLUSION

In the opinion of ACS, Inc. the model CPTP100, manufactured by Sensus Metering Systems, Inc., meets all the requirements of FCC Part 24D and Part 101 as well as Innovation, Science and Economic Development, Canada RSS-119 and RSS-134 where applicable.

End of Report