

Transmitter Certification

Test Report

FCC ID: SDBCPRLM01

**FCC Rule Part: CFR 47 Part 24 Subpart D, Part 90 Subpart I, Part 101
Subpart C**

ACS Report Number: 07-0126-LD

Applicant: Sensus Metering Systems
Model: GCVTF

Test Begin Date: March 19, 2007
Test End Date: March 21, 2007

Report Issue Date: April 3, 2007



FOR THE SCOPE OF ACCREDITATION UNDER LAB Code 200612-0

This report is not be used to claim certification, approval, or endorsement by NVLAP, NIST or any government agency.

Prepared by: _____
Jeff Woods
Wireless Certification Engineer
ACS, Inc.

Reviewed by: _____
J. Kirby Munroe
Manager Wireless Certifications
ACS, Inc.

This test report shall not be reproduced except in full. This report may be reproduced in part with prior written consent of ACS, Inc. The results contained in this report are representative of the sample(s) submitted for evaluation.

This report contains 41 pages

Table of Content

1.0 General	3
1.1 Purpose	3
1.2 Product Description	3
1.3 Test Methodology	3
1.3.2 In-Band Testing Methodology	3
1.4 Emission Designators	4
2.0 Test Facilities	5
2.1 Location	5
2.2 Laboratory Accreditations/Recognitions/Certifications	5
2.3 Radiated Emissions Test Site Description	6
2.3.1 Semi-Anechoic Chamber Test Site	6
2.3.2 Open Area Tests Site (OATS)	7
2.4 Conducted Emissions Test Site Description	8
3.0 Applicable Standards and References	8
4.0 List of Test Equipment	9
5.0 Support Equipment	10
6.0 EUT Setup and Block Diagram	10
7.0 Summary of Tests	11
7.1 RF Power Output	11
7.1.1 Measurement Procedure	11
7.1.2 Measurement Results	11
7.2 Occupied Bandwidth (Emission Limits)	15
7.2.1 Measurement Procedure	15
7.2.2 Measurement Results	15
7.3 Spurious Emissions at Antenna Terminals	22
7.3.1 Measurement Procedure	22
7.3.2 Measurement Results	22
7.4 Field Strength of Spurious Emissions	28
7.4.1 Measurement Procedure	28
7.4.2 Measurement Results	28
7.5 Frequency Stability	33
7.5.1 Measurement Procedure	33
7.5.2 Measurement Results	33
7.6 Radiated Emissions (Unintentional Radiators)	41
7.6.1 Measurement Procedure	41
7.6.2 Measurement Results	41
8.0 Conclusion	41

Additional Exhibits Included In Filing

Internal Photographs	External Photographs
Tune-up Procedure	Test Setup Photographs
Product Labeling	RF Exposure – MPE Calculations
Installation/Users Guide	System Block Diagram
Theory of Operation	Parts List
Schematics	

1.0 GENERAL

1.1 Purpose

The purpose of this report is to demonstrate compliance with Part 2 Subpart J, Part 24 Subpart D, Part 90 Subpart I, and Part 101 Subpart C of the FCC’s Code of Federal Regulations.

1.2 Product Description

The FlexNet Distribution Monitor consists of a printed circuit board, Cooper Line Monitor (CPRLM) transmitter, model GCVTF. This board contains the power supply, transmitter, and line monitor circuitry. The unit has an external permanently attached antenna with the following specifications:

Center Freq.	916MHz
Bandwidth	80MHz
Wavelength	1/2-wave
VSWR	<1.9 typ. at center
Impedance	50 ohms
Gain	0.44dBi
Connection	RG-178 coax
Polarization	Vertical

The device will be powered via a Current Transformer (CT) fed into the housing which has a spring loaded clamp that allows it to easily attach to existing power lines. A minimally sized AA lithium battery will be included to facilitate installation transmission and transmissions during power outages.

The device communicates via the Sensus fixed wireless telemetry network to provide line status information to utilities.

The device will transmit status (Health) information automatically at a programmable periodic rate and also when triggered by specific events such as a change of sensor status such as a high current event called a fault.

1.3 Test Methodology

1.3.1 In-Band Testing Methodology

For testing in accordance with 47 CFR 2.1046-2.1057, OET/Lab recommends that the following be used to select test frequencies for licensed devices:

Frequency range over which device operates	Number of frequencies	Location in the range of operation
1 MHz or less	1	Middle
1 to 10 MHz	2	1 near top and 1 near bottom
10 to 100 MHz	3	1 near top, 1 near middle and 1 near bottom

The GCVTF is designed to operate in multiple bands under the requirements of CFR 47 Parts 24, 90, and 101. The following is a list of the frequency bands of operation sorted based on the FCC rule parts in which the band is associated.

CFR Title 47 Rule Part	Frequency Band of Operation (MHz)
24D	901.0 - 902.0
24D	930.0 - 931.0
24D	940.0 - 941.0
90	896.0125 - 901.0
90	935.0 - 940.0
101	928.85 - 929.0
101	932.0 - 932.5
101	941.0 - 941.5
101	959.85 - 960.0

Based on the requirements set forth in accordance 47 CFR 2.1046-2.1057 as stated above, the methodology in selecting the places to test in the available bands of operation is outlined in the following table.

CFR Title 47 Rule Part	Frequency Band of Operation (MHz)	Location in the Range of Operation
90	896.0125 - 901.0	1 near top and 1 near bottom
24D	901.0 - 902.0	
101	928.85 - 929.0	Middle
24D	930.0 - 931.0	Middle
101	932.0 - 932.5	Middle
90	935.0 - 940.0	1 near top and 1 near bottom
24D	940.0 - 941.0	
101	941.0 - 941.5	
101	959.85 - 960.0	Middle

The data provided in this report is sorted based on the rule part.

1.4 Emission Designators

The GCVTF transmitter produces four distinct modulation formats. The necessary bandwidth calculations for these formats may be found in a separate document.

The emissions designators for the four modulation types used by the GCVTF Transmitter are as follows:

EMISSIONS DESIGNATORS:

- Normal Mode: 9K60F2D
- Half-Baudrate Mode: 4K80F2D
- Boost Mode: 1K10F2D
- MPass Mode: 5K90F1D

2.0 TEST FACILITIES

2.1 Location

The radiated and conducted emissions test sites are located at the following address:

Advanced Compliance Solutions
5015 B.U. Bowman Drive
Buford, GA 30518
Phone: (770) 831-8048
Fax: (770) 831-8598

2.2 Laboratory Accreditations/Recognitions/Certifications

The Semi-Anechoic Chamber Test Site, Open Area Test Site (OATS) and Conducted Emissions Site have been fully described, submitted to, and accepted by the FCC, Industry Canada and the Japanese Voluntary Control Council for Interference by information technology equipment. In addition, ACS is compliant to ISO 17025 as certified by the National Institute of Standards and Technology under their National Voluntary Laboratory Accreditation Program. The following certification numbers have been issued in recognition of these accreditations and certifications:

FCC Registration Number: 89450
Industry Canada Lab Code: IC 4175
VCCI Member Number: 1831
- VCCI OATS Registration Number R-1526
- VCCI Conducted Emissions Site Registration Number: C-1608
NVLAP Lab Code: 200612-0

2.3 Radiated Emissions Test Site Description

2.3.1 Semi-Anechoic Chamber Test Site

The Semi-Anechoic Chamber Test Site consists of a 20' x 30' x 18' shielded enclosure. The chamber is lined with Toyo Ferrite Grid Absorber, model number FFG-1000. The ferrite tile grid is 101 x 101 x 19mm thick and weighs approximately 550 grams. These tiles are mounted on steel panels and installed directly on the inner walls of the chamber.

The turntable is 150cm in diameter and is located 160cm from the back wall of the chamber. The chamber is grounded via 1 - 8' copper ground rod, installed at the center of the back wall, it is bound to the ground plane using 3/4" stainless steel braided cable.

The turntable is all steel, flush mounted table installed in an all steel frame. The table is remotely operated from inside the control room located 25' from the range. The turntable is electrically bonded to the surrounding ground plane via steel fingers installed on the edge of the turn table. The steel fingers make constant contact with the ground plane during operation.

Behind the turntable is a 3' x 6' x 4' deep shielded pit used for support equipment if necessary. The pit is equipped with 1 - 4" PVC chases from the turntable to the pit that allow for cabling to the EUT if necessary. The underside of the turntable can be accessed from the pit so cables can be supplied to the EUT from the pit.

A diagram of the Semi-Anechoic Chamber Test Site is shown in Figure 2.3-1 below:

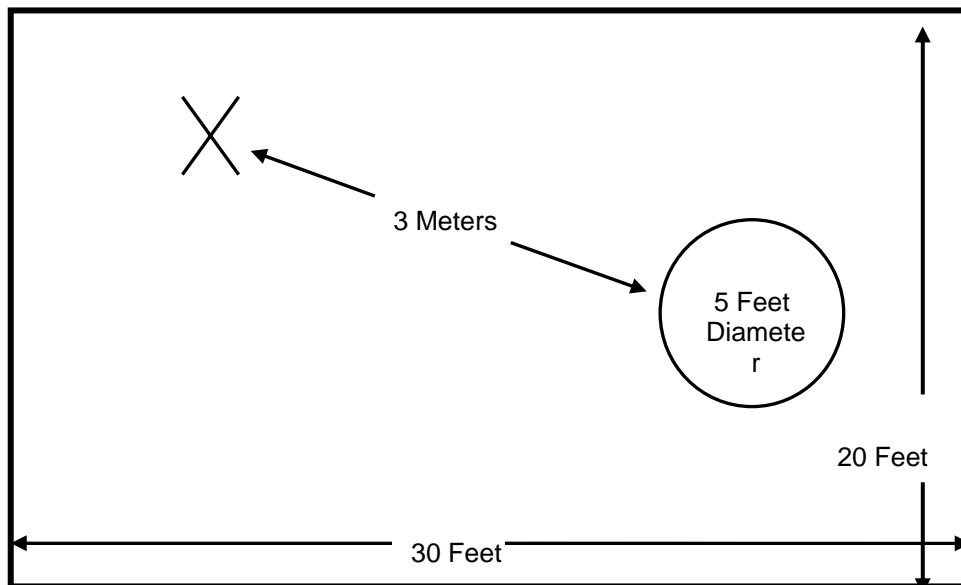

Figure 2.3-1: Semi-Anechoic Chamber Test Site

2.3.2 Open Area Tests Site (OATS)

The open area test site consists of a 40' x 66' concrete pad covered with a perforated electro-plated galvanized sheet metal. The perforations in the sheet metal are 1/8" holes that are staggered every 3/16". The individual sheets are placed to overlap each other by 1/4" and are riveted together to provide a continuous seam. Rivets are spaced every 3" in a 3 x 20 meter perimeter around the antenna mast and EUT area. Rivets in the remaining area are spaced as necessary to properly secure the ground plane and maintain the electrical continuity.

The entire ground plane extends 12' beyond the turntable edge and 16' beyond the antenna mast when set to a 10 meter measurement distance. The ground plane is grounded via 4 - 8' copper ground rods, each installed at a corner of the ground plane and bound to the ground plane using 3/4" stainless steel braided cable.

The turntable is an all aluminum 10' flush mounted table installed in an all aluminum frame. The table is remotely operated from inside the control room located 40' from the range. The turntable is electrically bonded to the surrounding ground plane via steel fingers installed on the edge of the turn table. The steel fingers make constant contact with the ground plane during operation.

Adjacent to the turntable is a 7' x 7' square and 4' deep concrete pit used for support equipment if necessary. The pit is equipped with 5 - 4" PVC chases from the pit to the control room that allow for cabling to the EUT if necessary. The underside of the turntable can be accessed from the pit so cables can be supplied to the EUT from the pit. The pit is covered with 2 sheets of 1/4" diamond style re-enforced steel sheets. The sheets are painted to match the perforated steel ground plane; however the underside edges have been masked off to maintain the electrical continuity of the ground plane. All reflecting objects are located outside of the ellipse defined in ANSI C63.4.

A diagram of the Open Area Test Site is shown in Figure 2.3-2 below:

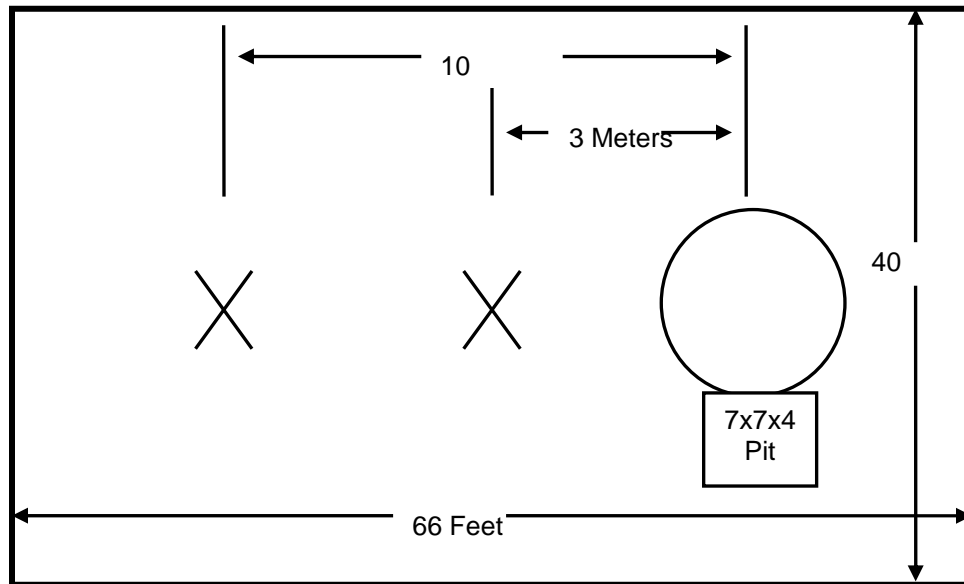

Figure 2.3-2: Open Area Test Site

2.4 Conducted Emissions Test Site Description

The AC mains conducted EMI site is located in the main EMC lab. It consists of an 8' x 8' solid aluminum horizontal group reference plane (GRP) bonded every 3" to an 8' X 8' vertical ground plane.

The site is of sufficient size to test table top and floor standing equipment in accordance with section 6.1.4 of ANSI C63.4.

A diagram of the room is shown below in figure 4.1.3-1:

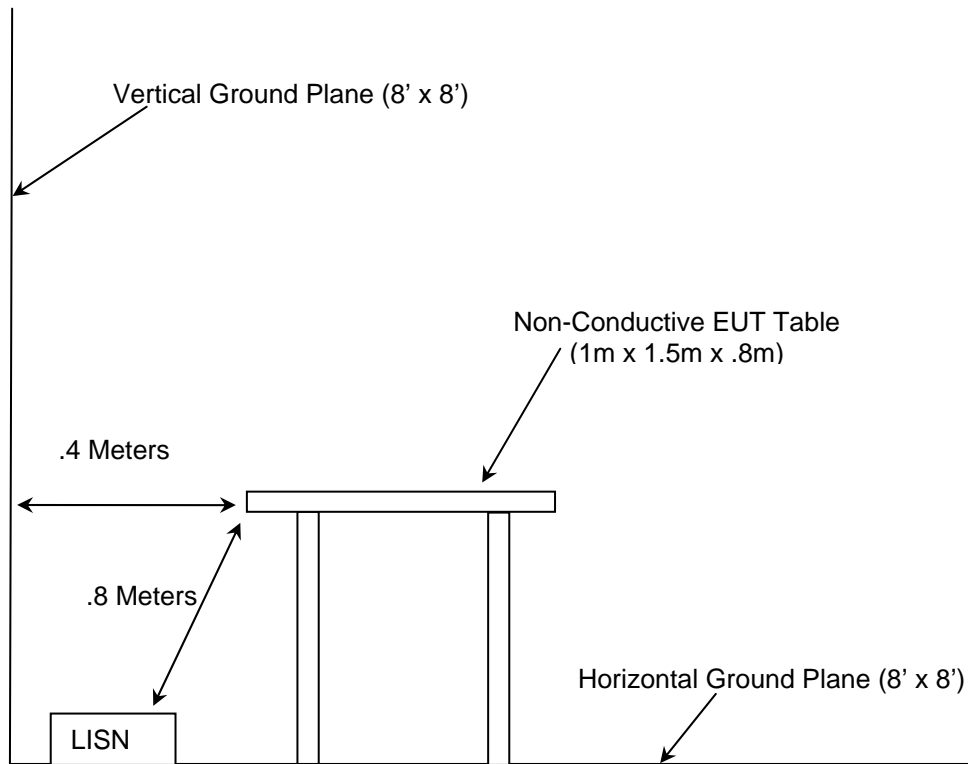

Figure 2.4-1: AC Mains Conducted EMI Site

3.0 APPLICABLE STANDARD REFERENCES

The following standards were used:

- 1 - ANSI C63.4-2003: Method of Measurements of Radio-Noise Emissions from Low-Voltage Electrical and Electronic Equipment in the 9KHz to 40GHz - 2003
- 2 -US Code of Federal Regulations (CFR): Title 47, Part 2, Subpart J: Equipment Authorization Procedures - 2006
- 3 - US Code of Federal Regulations (CFR): Title 47, Part 24, Subpart D: Personal Communication Service - 2006
- 4 - US Code of Federal Regulations (CFR): Title 47, Part 90, Subpart I: Private Land Mobile Radio Services - 2006
- 5 - US Code of Federal Regulations (CFR): Title 47, Part 101, Subpart C: Fixed Microwave Services – 2006
- 6 – TIA-603-C: Land Mobile FM or PM - Communications Equipment - Measurement and Performance Standards - 2004

4.0 LIST OF TEST EQUIPMENT

All test equipment used for regulatory testing is calibrated yearly or according to manufacturer's specifications.

Table 4-1: Test Equipment

Equipment Calibration Information					
ACS#	Mfg.	Eq. type	Model	S/N	Cal. Due
25	Chase	Bi-Log Antenna	CBL6111	1043	5/30/07
22	Agilent	Pre-Amplifier	8449B	3008A00526	4/10/08
73	Agilent	Pre-Amplifier	8447D	272A05624	5/03/07
30	Spectrum Technologies	Horn Antenna	DRH-0118	970102	5/12/07
---	A.H. Systems	Horn Antenna	SAS-571	721	8/24/07
105	Microwave Circuits	High Pass Filter	H3G020G4	74541DC0608	3/5/08
3	Rohde & Schwarz	Receiver Display	804.8932.52	839379/011	3/5/08
4	Rohde & Schwarz	ESMI Receiver	1032.5640.53	833827/003	3/5/08
283	Rohde & Schwarz	Spectrum Analyzer	FSP	100033	3/24/07
140	Thermotron	Environmental Chamber	SM-16C	19639	8/30/07
290	Florida RF Labs	HF RF Cable	SMSE-200-72.0-SMRE	NA	5/08/07
291	Florida RF Labs	HF RF Cable	SMRE-200W-12.0-SMRE	NA	5/08/07
292	Florida RF Labs	HF RF Cable	SMR-280AW-480.0-SMR	NA	5/24/07
167	ACS	Chamber EMI Cable Set	RG6	167	1/5/08
237	Gigatronics	Signal Generator	1018	315110	4/16/08
---	Agilent	Signal Generator	E4438C	MY45082439	4/9/08

5.0 SUPPORT EQUIPMENT

Table 5-1: Support Equipment

Diagram #	Manufacturer	Equipment Type	Model Number	Serial Number	FCC ID
1	Sensus	EUT	GCVTF	None	SDBCPRLM01
2	OK Industries	DC Power Supply	PS73C	36095	None

6.0 EQUIPMENT UNDER TEST SETUP AND BLOCK DIAGRAM

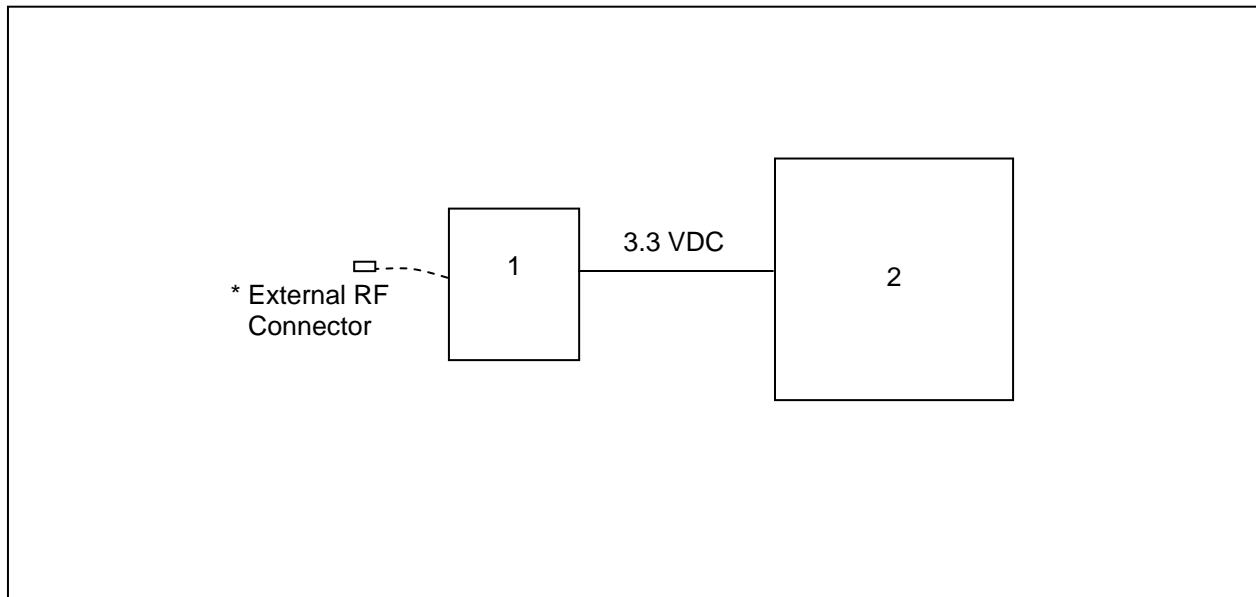

Figure 6-1: EUT Test Setup

* For RF conducted and transmitter radiated spurious emissions measurements, the GCVTF transmitter was modified with an external RF connector to the PCB. The GCVTF transmitter utilizes a non-detachable ½ wave dipole antenna for normal operation but for testing purposes the antenna was disconnected and a 50-Ohm test cable soldered (with the appropriate ground connection) to the PCB. The EUT test cable was connected to non-radiating 50 Ohm load for transmitter radiated measurements.

For the purpose of testing to Part 15 for unintentional radiators, the EUT was tested with the antenna connected.

7.0 SUMMARY OF TESTS

Along with the tabular data shown below, plots were taken of all signals deemed important enough to document.

7.1 RF Power Output - FCC Section 2.1046

7.1.1 Measurement Procedure

The RF output of the equipment under test was directly connected to the input of the Spectrum Analyzer through a 20 dB passive attenuator. The resolution and video bandwidths of the spectrum analyzer were set at sufficient levels, >> signal bandwidth, to produce accurate results. The internal correction factors of the spectrum analyzer were employed to correct for any cable or attenuator losses. Results are shown below in Table 7.1.2-1 and Figure 7.1.2-1 through 7.1.2-8.

7.1.2 Measurement Results

Table 7.1.2-1: Peak Output Power

Frequency (MHz)	FCC Rule Part	Output Power (dBm)
901.9875	Part 24	30.56
930.5000	Part 24	30.40
896.0125	Part 90	30.58
935.0125	Part 90	30.32
928.9250	Part 101	30.39
932.2500	Part 101	30.37
941.4875	Part 101	30.23
959.9250	Part 101	29.90

Part 24

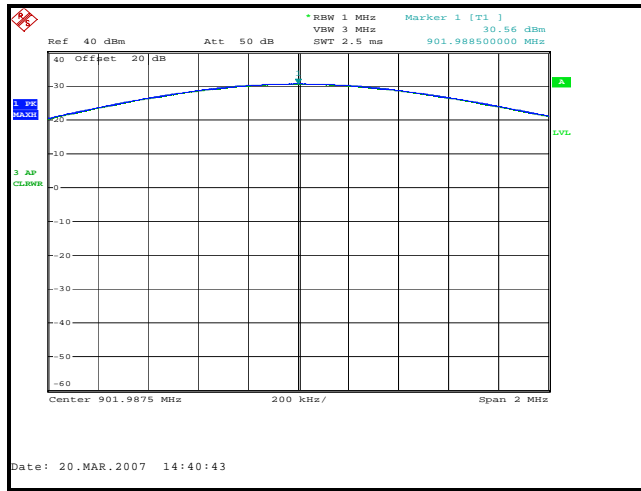

Figure 7.1.2-1: Peak Output Power 901.9875 MHz

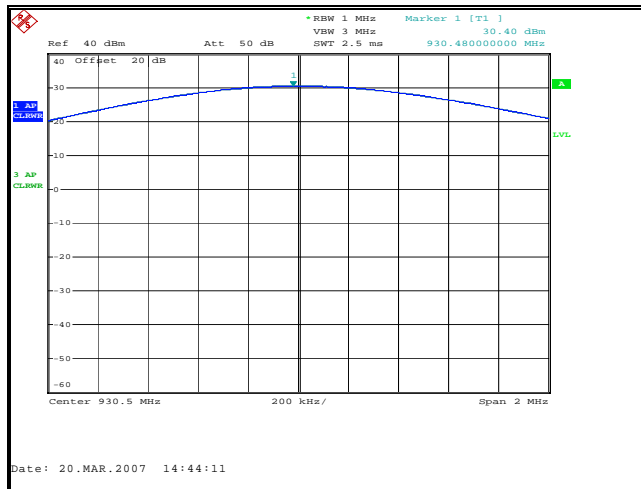

Figure 7.1.2-2: Peak Output Power 930.5 MHz

Part 90

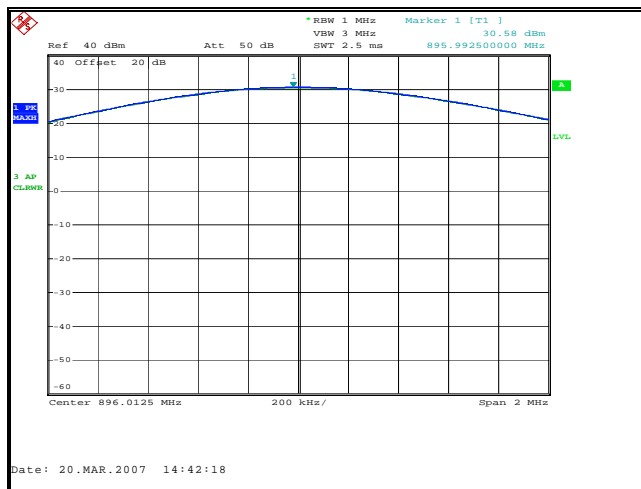

Figure 7.1.2-3: Peak Output Power 896.0125 MHz

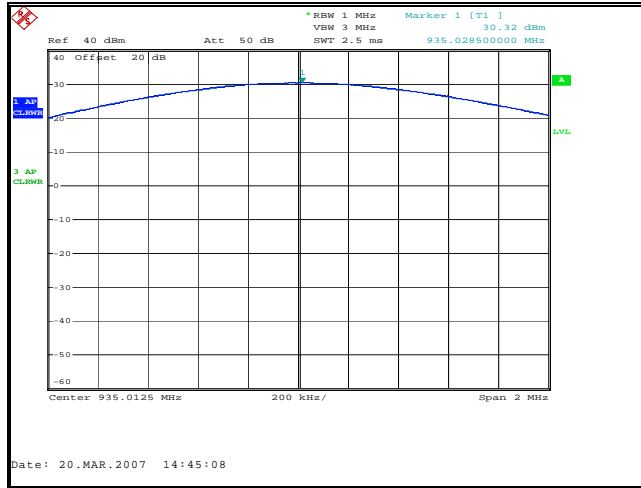

Figure 7.1.2-4: Peak Output Power 935.0125 MHz

Part 101

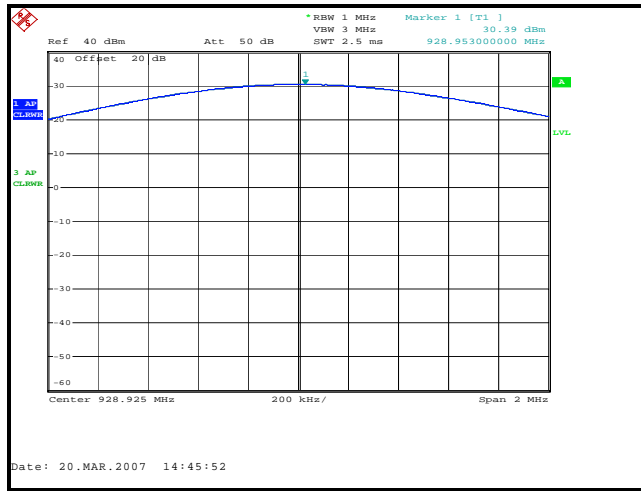

Figure 7.1.2-5: Peak Output Power 928.925 MHz

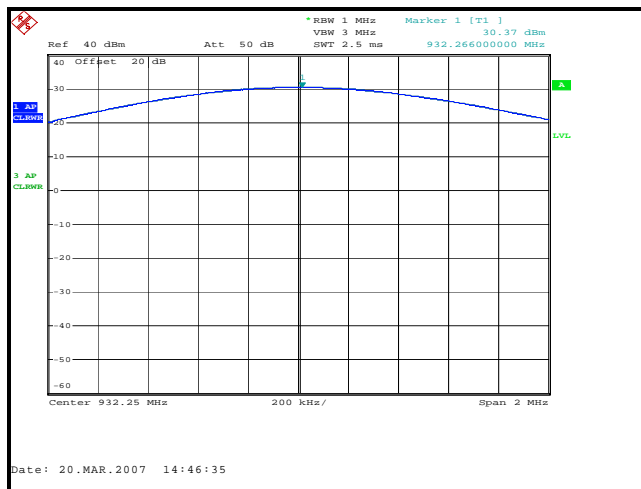

Figure 7.1.2-6: Peak Output Power 932.25 MHz

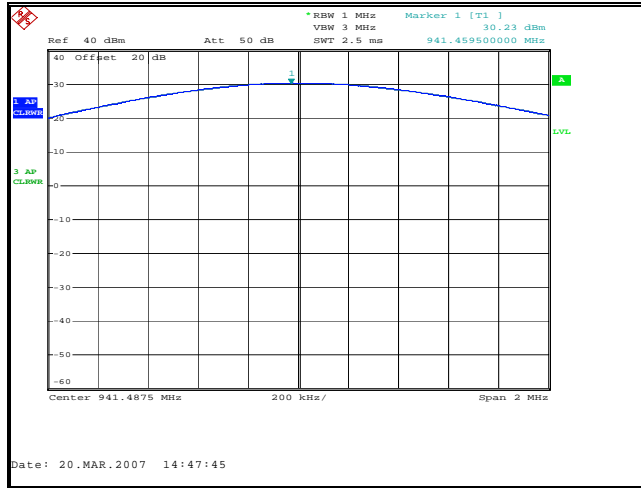

Figure 7.1.2-7: Peak Output Power 941.4875 MHz

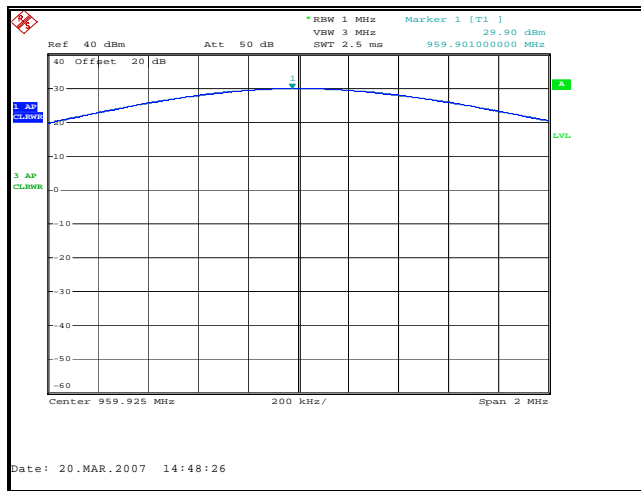

Figure 7.1.2-8: Peak Output Power 959.925 MHz

7.2 Occupied Bandwidth (Emission Limits) - FCC Section 2.1049

7.2.1 Measurement Procedure

The RF output of the equipment under test was directly connected to the input of the Spectrum Analyzer through a 20 dB passive attenuator. The spectrum analyzer resolution and video bandwidths were set to 300 Hz. The internal correction factors of the spectrum analyzer were employed to correct for any cable or attenuator losses. Results of the test are shown below for all modes of operation.

7.2.2 Measurement Results – Part 24.133 a(1), a(2)

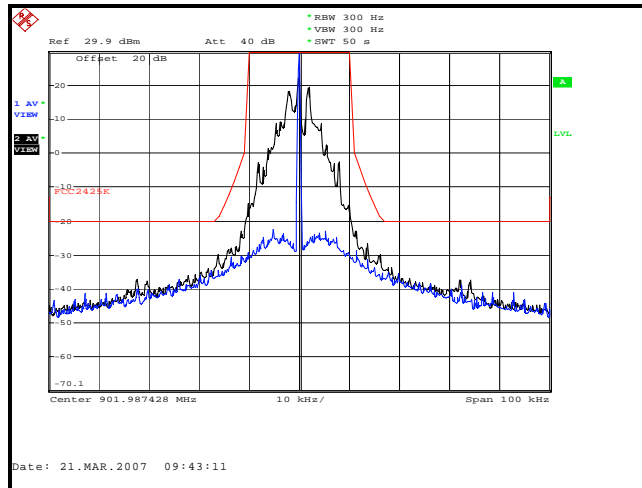

Figure 7.2.2-1: Normal Mode – 901.9875 MHz – 25 kHz Channel

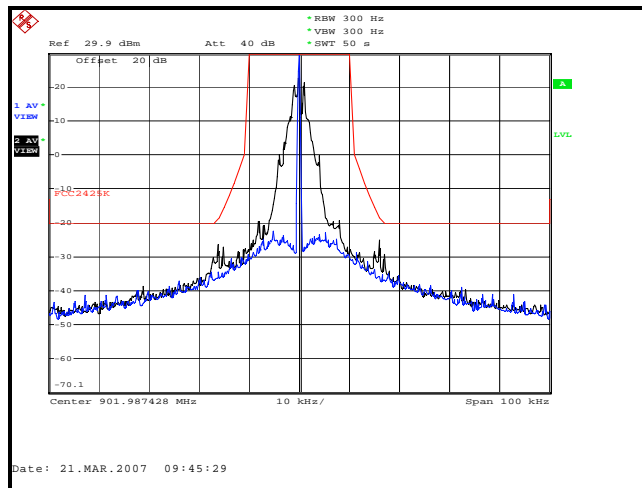

Figure 7.2.2-2: Half-Baud Rate Mode – 901.9875 MHz – 25 kHz Channel

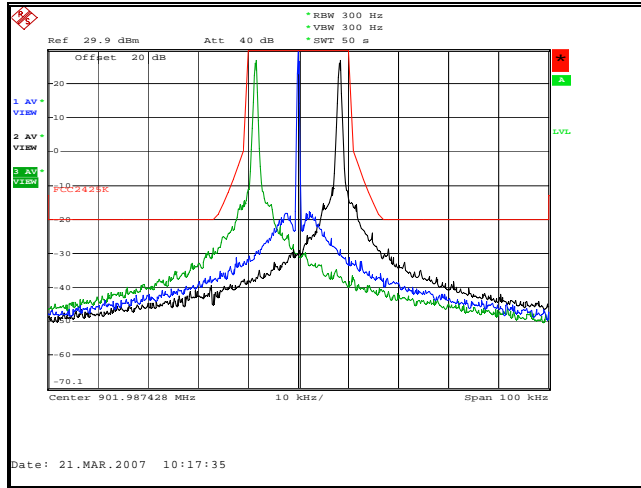

Figure 7.2.2-3: Boost Mode – 901.9875 MHz – 25 kHz Channel Offset Channel of +/- 14 (+/- 8400 Hz)

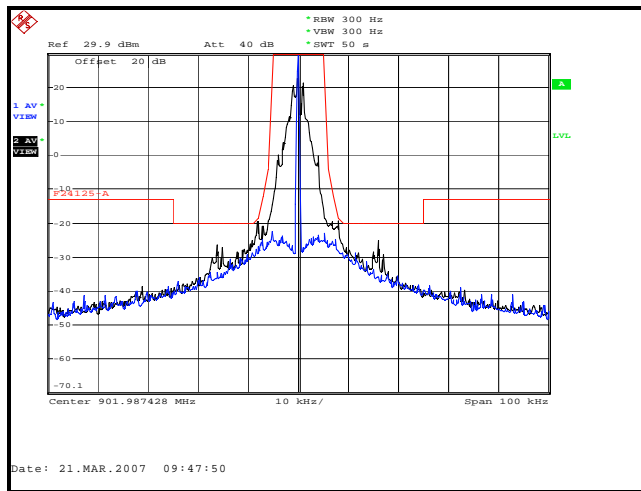

Figure 7.2.2-4: Half-Baud Rate – 901.9875 MHz – 12.5 kHz Channel

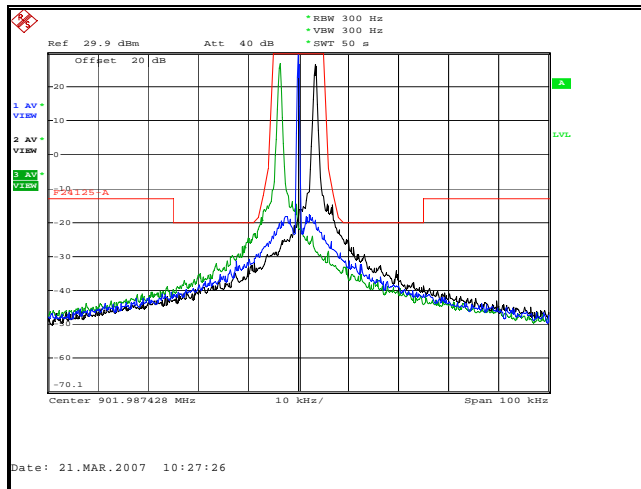

Figure 7.2.2-5: Boost Mode – 901.9875 MHz – 12.5 kHz Channel Offset Channel of +/- 6 (+/- 3600 Hz)

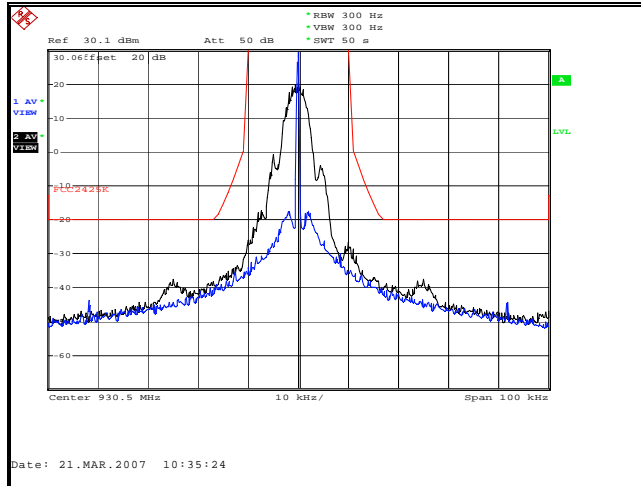

Figure 7.2.2-6: MPass Mode – 930.5 MHz – 25 kHz Channel

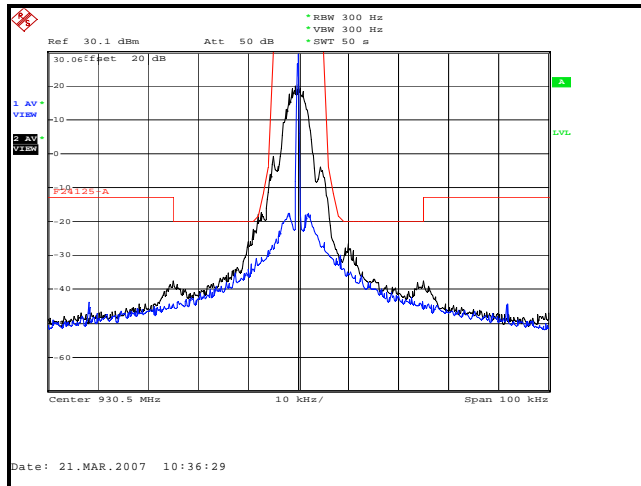

Figure 7.2.2-7: MPass Mode – 930.5 MHz – 12.5 kHz Channel

7.2.3 Measurement Results – Part 90.210 (j)

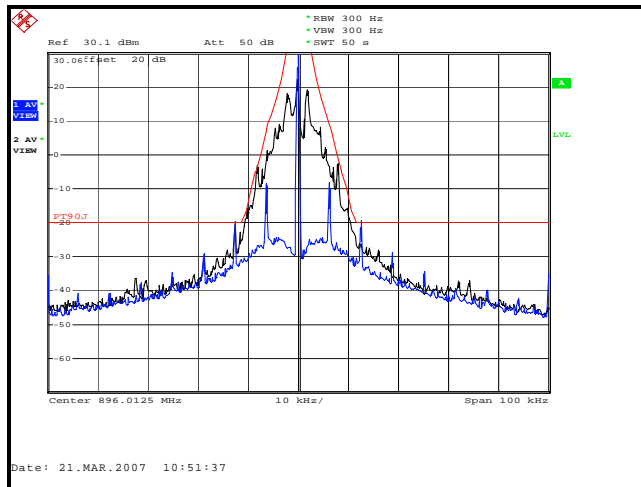

Figure 7.2.3-1: Normal Mode – 896.0375 MHz

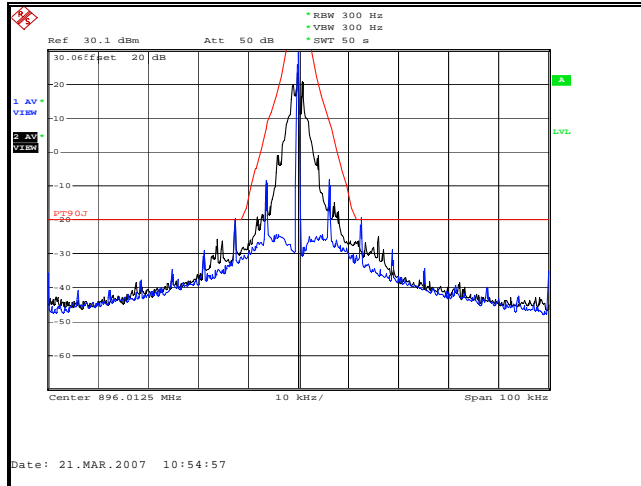

Figure 7.2.3-2: Half-Baud Rate Mode – 896.0375 MHz

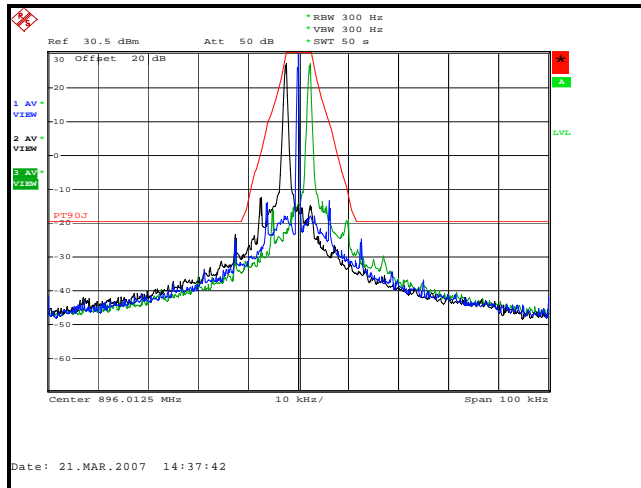

Figure 7.2.3-3: Boost Mode – 896.0375 MHz
Offset Channel of +/- 4 (+/- 2400 Hz)

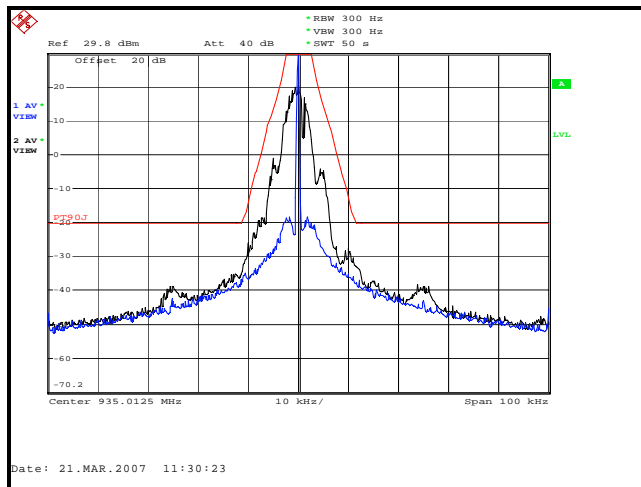

Figure 7.2.3-4: MPass Mode – 935.0125 MHz

7.2.4 Measurement Results – Part 101.111 a(6)

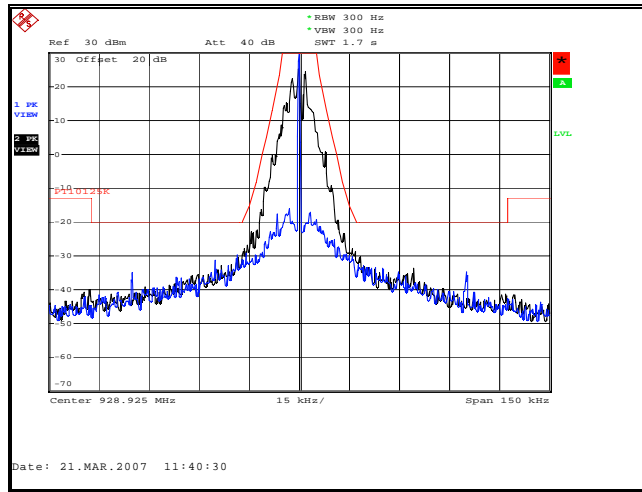

Figure 7.2.4-1: Normal Mode – 928.925 MHz

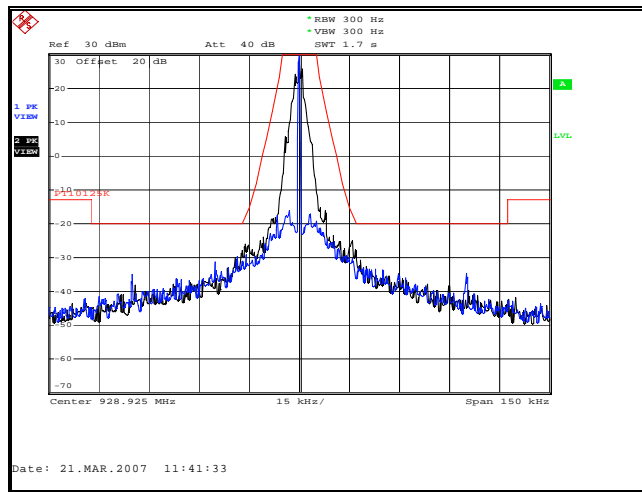

Figure 7.2.4-2: Half-Baud Rate Mode – 928.925 MHz

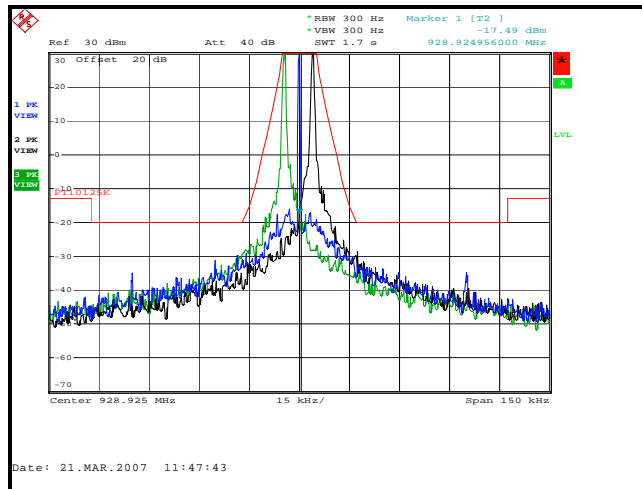

Figure 7.2.4-3: Boost Mode – 928.925 MHz
Offset Channel of +/- 7 (+/- 4200 Hz)

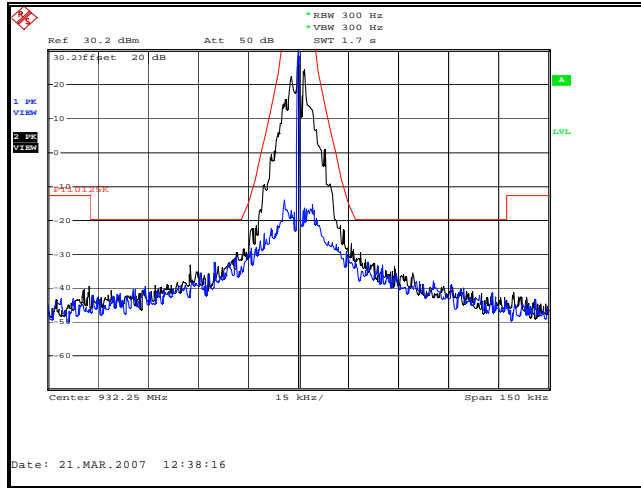

Figure 7.2.4-4: Normal Mode – 932.25 MHz

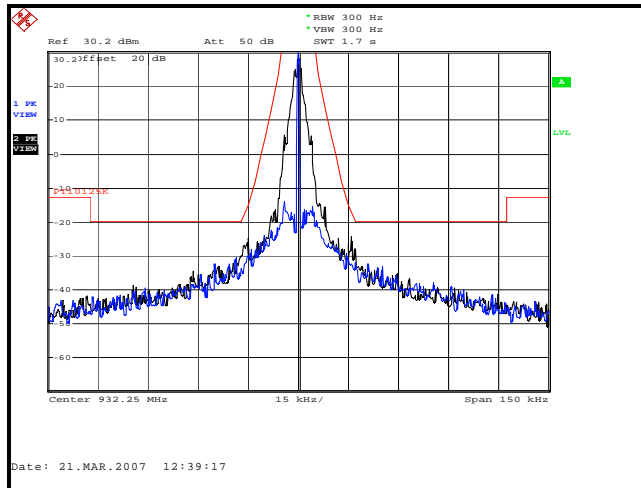

Figure 7.2.4-5: Half-Baud Rate Mode – 932.25 MHz

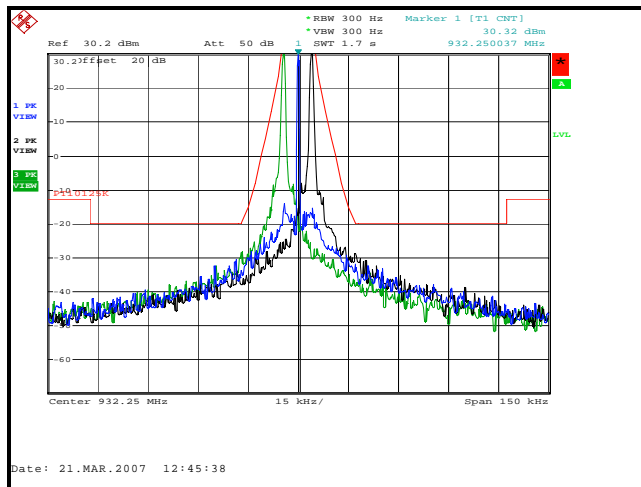

Figure 7.2.4-6: Boost Mode – 932.25 MHz
Offset Channel of +/- 7 (+/- 4200 Hz)

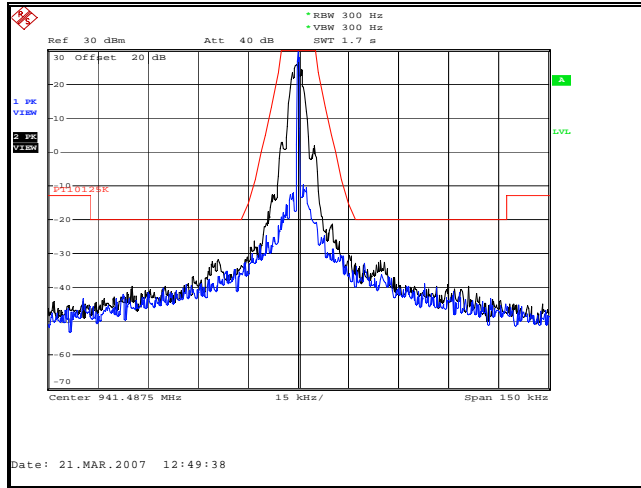

Figure 7.2.4-7: MPass Mode – 941.4875 MHz

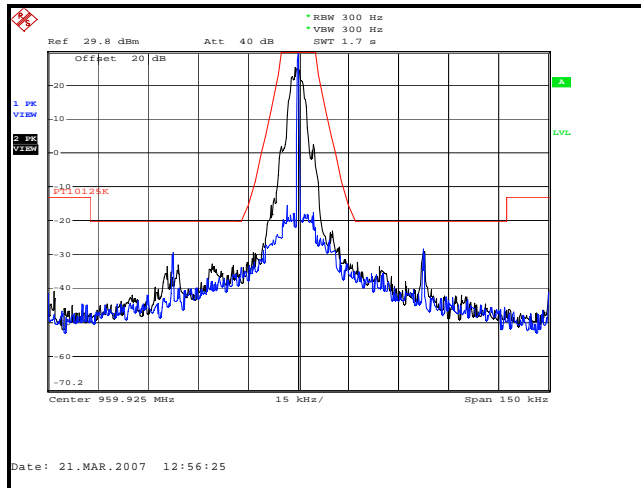

Figure 7.2.4-8: MPass Mode – 959.925 MHz

7.3 Spurious Emissions at Antenna Terminals - FCC Section 2.1051; 24.133 a(1), a(2); 90.210 (j); 101.111 a (6)

7.3.1 Measurement Procedure

The RF output of the equipment under test was directly connected to the input of the Spectrum Analyzer through a 20 dB passive attenuator. The spectrum analyzer resolution bandwidth was set to 30 kHz below 1000 MHz and 1 MHz above 1000 MHz. The internal correction factors of the spectrum analyzer were employed to correct for any cable or attenuator losses. The spectrum was investigated in accordance to CFR 47 Part 2.1057.

7.3.2 Measurement Results

Data was collected according to Section 1.3.2 in the mode that produced the worst case emissions. Plots are supplied in **Figure 7.3.2-1 through 7.3.2.16**.

PART 24

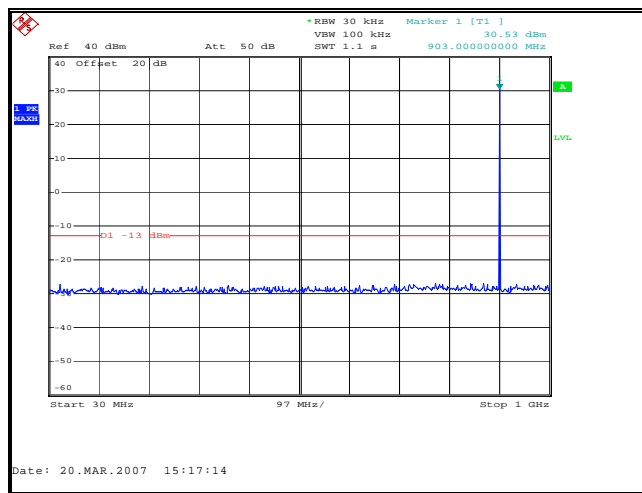

Figure 7.3.2-1: Normal Mode – 901.9875 MHz – 30MHz to 1GHz

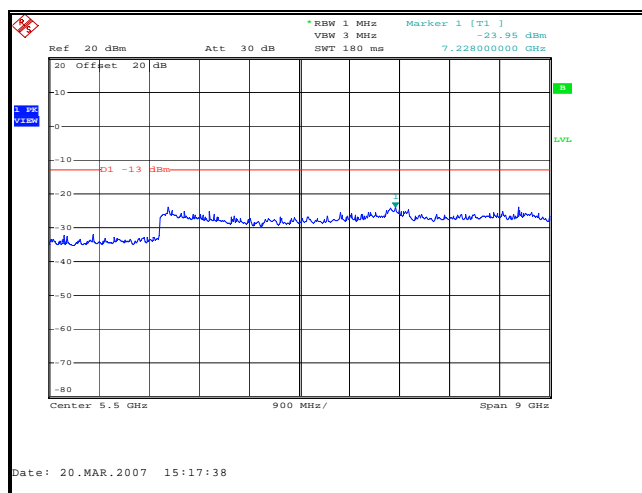

Figure 7.3.2-2: Normal Mode – 901.9875 MHz – 1GHz to 10GHz

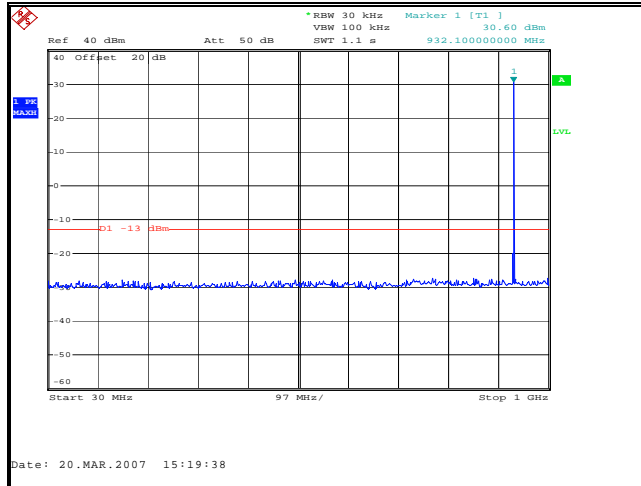

Figure 7.3.2-3: Mpass Mode – 930.5 MHz – 30MHz to 1GHz

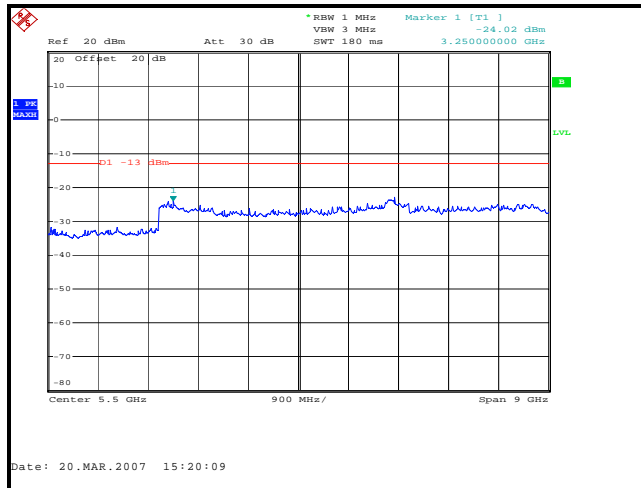

Figure 7.3.2-4: Mpass Mode – 930.5 MHz – 1GHz to 10GHz

PART 90

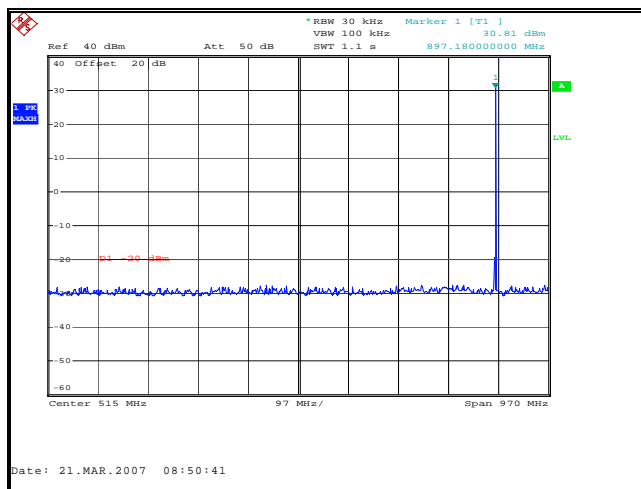

Figure 7.3.2-5: Normal Mode – 896.0125 MHz – 30MHz to 1GHz

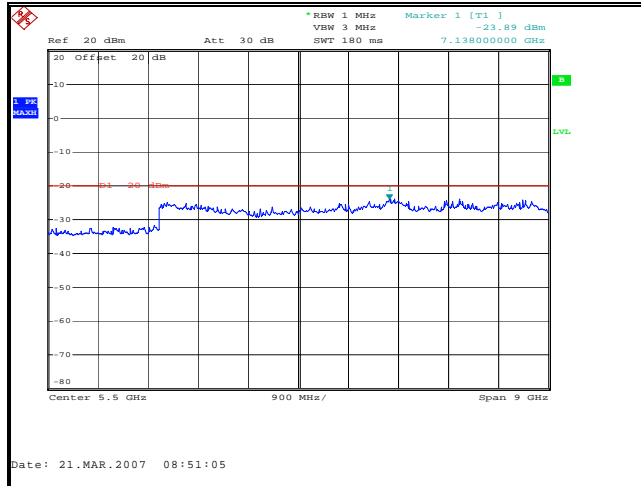

Figure 7.3.2-6: Normal Mode – 896.0125 MHz – 1GHz to 10GHz

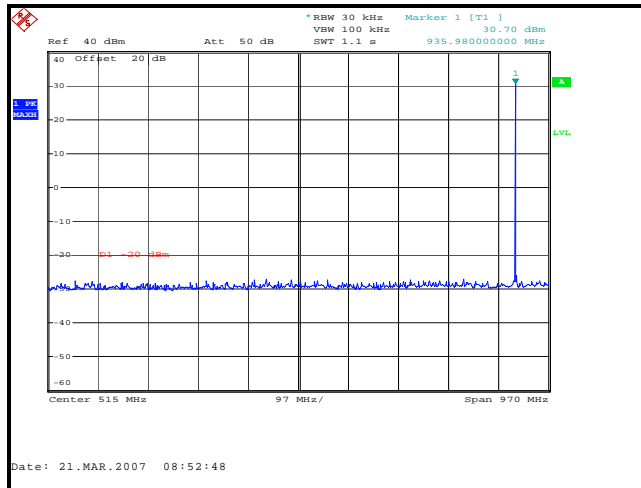

Figure 7.3.2-7: MPassMode – 935.0125 MHz – 30MHz to 1GHz

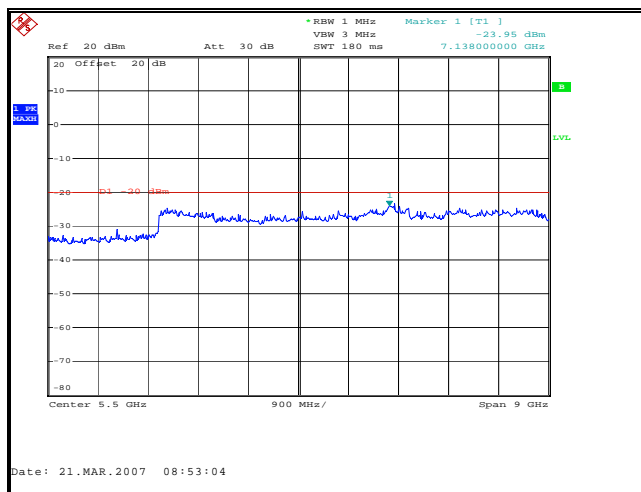

Figure 7.3.2-8: MPass Mode – 935.0125 MHz – 1GHz to 10GHz

PART 101

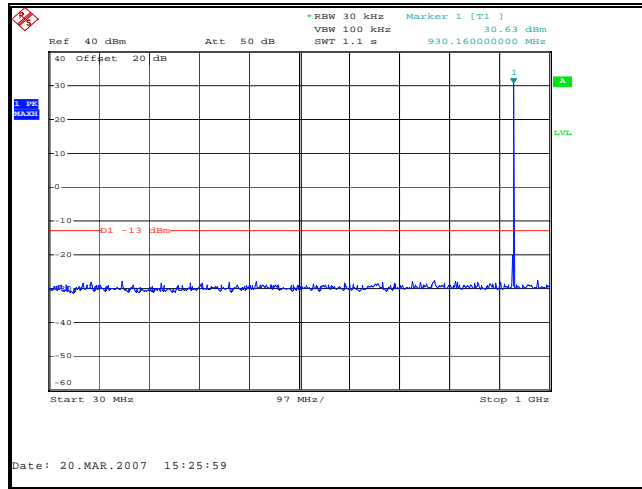

Figure 7.3.2-9: Normal Mode – 928.925 MHz – 30MHz to 1GHz

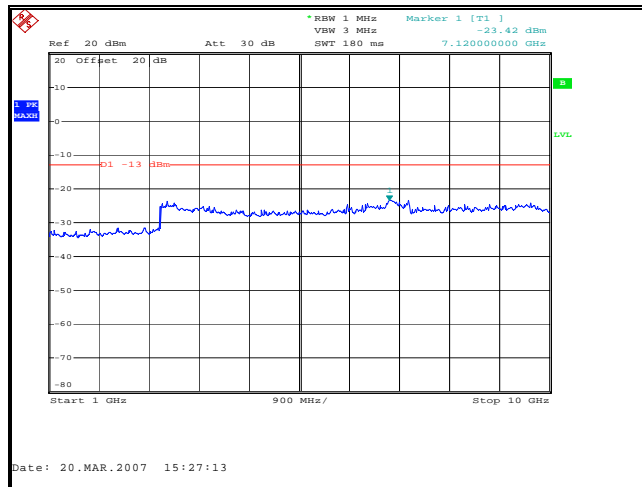

Figure 7.3.2-10: Normal Mode – 928.925 MHz – 1GHz to 10GHz

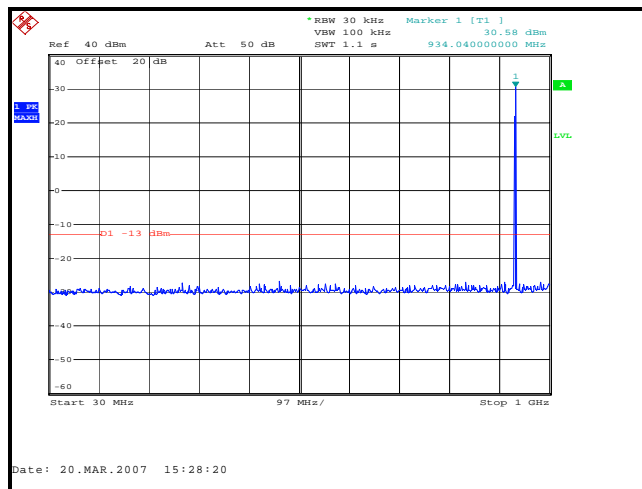

Figure 7.3.2-11: Normal Mode – 932.25 MHz – 30MHz to 1GHz

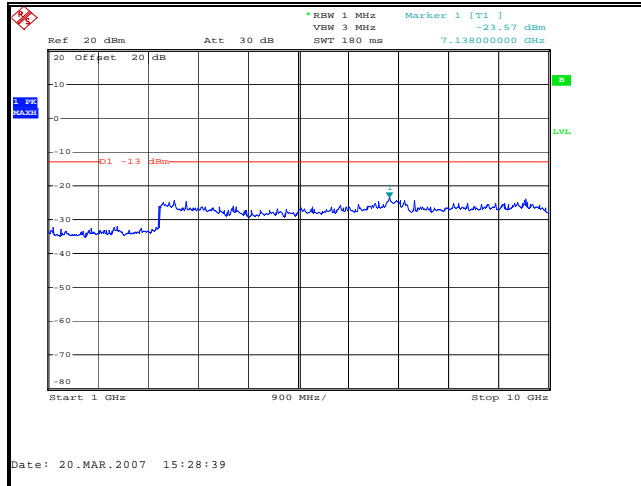

Figure 7.3.2-12: Normal Mode – 932.25 MHz – 1GHz to 10GHz

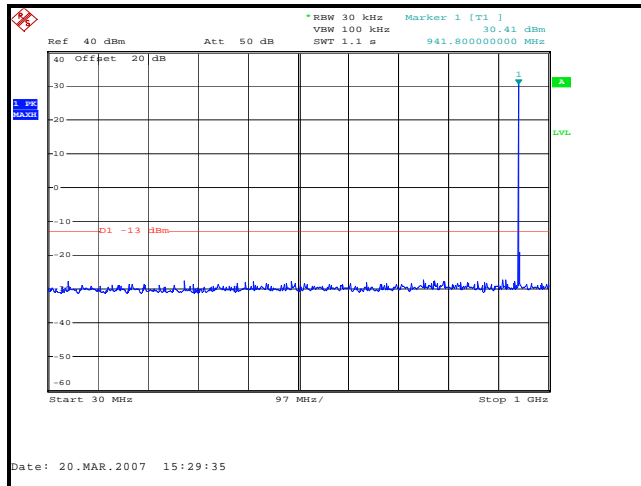

Figure 7.3.2-13: MPass Mode – 941.4875 MHz – 30MHz to 1GHz

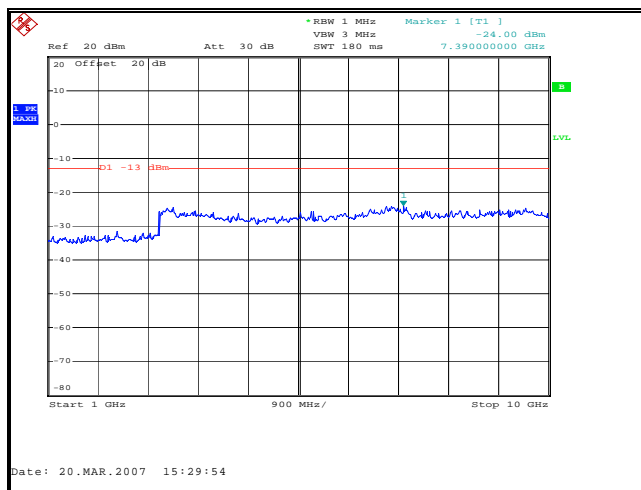

Figure 7.3.2-14: MPass Mode – 941.4875 MHz – 1GHz to 10GHz

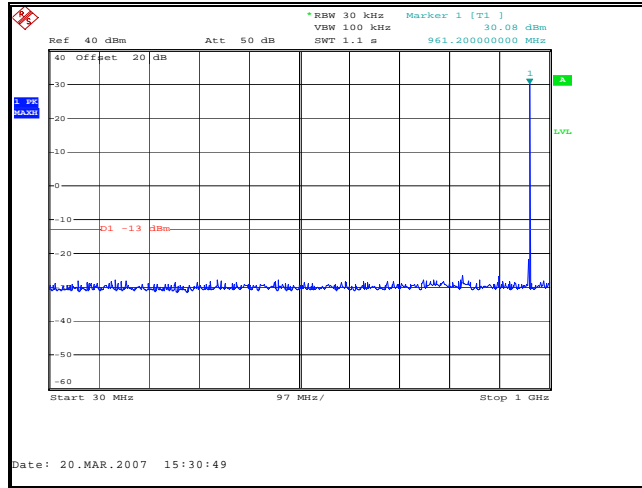

Figure 7.3.2-15: MPass Mode – 959.925 MHz – 30MHz to 1GHz

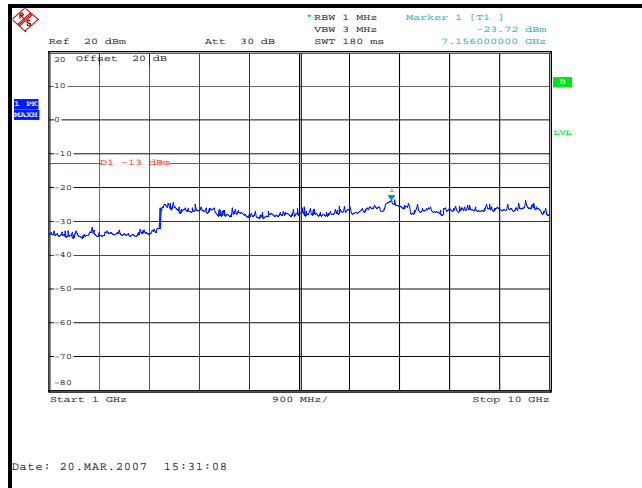

Figure 7.3.2-16: MPass Mode – 959.925 MHz – 1GHz to 10GHz

7.4 Field Strength of Spurious Emissions - FCC Section 2.1053, 24.133, 90.210, and 101.111

7.4.1 Measurement Procedure

The equipment under test is placed in the Semi-Anechoic Chamber (described in section 2.3.1) on a wooden table at the turntable center. For each spurious emission, the antenna mast is raised and lowered from one (1) to four (4) meters and the turntable is rotated 360° and the maximum reading on the spectrum analyzer is recorded. This was repeated for both horizontal and vertical polarizations of the receive antenna.

The equipment under test is then replaced with a substitution antenna fed by a signal generator. The signal generator’s frequency is set to that of the spurious emission recorded from the equipment under test. The antenna mast is raised and lowered from one (1) to four (4) meters to obtain a maximum reading on the spectrum analyzer. The output of the signal generator is then adjusted until the reading on the spectrum analyzer matches that obtained from the equipment under test. The signal generator level is recorded. The power in dBm of each spurious emission is calculated by correcting the signal generator level for the cable loss and gain of the substitution antenna referenced to a dipole. The spectrum was investigated in accordance to CFR 47 Part 2.1057.

Data was collected at frequencies according to Section 1.3.2. Results of the test are shown below. The magnitude of all spurious emissions not reported were attenuated below the noise floor of the measurement system and therefore not specified in this report.

The equipment under test was evaluated to multiple FCC rule parts with the most stringent limit applied to all measurements.

7.4.2 Measurement Results

PART 24

Table 7.4.2-1: Field Strength of Spurious Emissions – 901.9875 MHz – Normal Mode

Frequency (MHz)	Spectrum Analyzer Level (dBm)	Generator Level (dBm)	Antenna Polarity (H/V)	Correction Factors (dB)	Corrected Level (dBm)	Limit (dBm)	Margin (dB)
1803.975	-51.92	-56.00	H	5.44	-50.56	-20.00	30.56
1803.975	-51.34	-56	V	5.32	-50.68	-20.00	30.68
2705.9625	-53.67	-54	H	5.62	-48.38	-20.00	28.38
2705.9625	-54.41	-57	V	5.84	-51.16	-20.00	31.16
3607.95	-53.34	-52	H	5.91	-46.09	-20.00	26.09
3607.95	-54.48	-56	V	5.86	-50.14	-20.00	30.14
4509.9375	-49.81	-48	H	6.50	-41.50	-20.00	21.50
4509.9375	-48.09	-46	V	6.50	-39.50	-20.00	19.50
5411.925	-54.31	-52	H	5.78	-46.22	-20.00	26.22
5411.925	-51.74	-48	V	5.60	-42.40	-20.00	22.40
6313.9125	-53.06	-47	H	5.80	-41.20	-20.00	21.20
6313.9125	-55.07	-50	V	5.77	-44.23	-20.00	24.23
7215.9	-54.66	-47	H	4.99	-42.01	-20.00	22.01
7215.9	-53.77	-46	V	5.03	-40.97	-20.00	20.97
8117.8875	-54.43	-46	H	5.60	-40.40	-20.00	20.40
8117.8875	-54.89	-47	V	5.60	-41.40	-20.00	21.40
9019.875	-55.04	-43	H	5.88	-37.12	-20.00	17.12
9019.875	-54.99	-47	V	5.97	-41.03	-20.00	21.03

Table 7.4.2-2: Field Strength of Spurious Emissions – 930.5 MHz – MPass Mode

Frequency (MHz)	Spectrum Analyzer Level (dBm)	Generator Level (dBm)	Antenna Polarity (H/V)	Correction Factors (dB)	Corrected Level (dBm)	Limit (dBm)	Margin (dB)
1861	-47.55	-48.00	H	5.49	-42.51	-20.00	22.51
1861	-47.37	-50	V	5.40	-44.60	-20.00	24.60
2791.5	-51.64	-49	H	5.68	-43.32	-20.00	23.32
2791.5	-52.25	-56	V	5.86	-50.14	-20.00	30.14
3722	-54.74	-49	H	5.84	-43.16	-20.00	23.16
3722	-52	-52	V	5.75	-46.25	-20.00	26.25
4652.5	-49.36	-46	H	6.35	-39.65	-20.00	19.65
4652.5	-47.27	-44	V	6.32	-37.68	-20.00	17.68
5583	-52.3	-50	H	5.80	-44.20	-20.00	24.20
5583	-49.28	-46	V	5.62	-40.38	-20.00	20.38
6513.5	-54.28	-48	H	5.61	-42.39	-20.00	22.39
6513.5	-52.83	-45	V	5.61	-39.39	-20.00	19.39
7444	-55.88	-50	H	5.15	-44.85	-20.00	24.85
7444	-55.12	-48	V	5.24	-42.76	-20.00	22.76
8374.5	-53.04	-43	H	5.64	-37.36	-20.00	17.36
8374.5	-53.24	-43	V	5.64	-37.36	-20.00	17.36
9305	-55.93	-46	H	6.04	-39.96	-20.00	19.96
9305	-57.2	-50	V	6.02	-43.98	-20.00	23.98

PART 90

Table 7.4.2-3: Field Strength of Spurious Emissions – 896.0125MHz – Normal Mode

Frequency (MHz)	Spectrum Analyzer Level (dBm)	Generator Level (dBm)	Antenna Polarity (H/V)	Correction Factors (dB)	Corrected Level (dBm)	Limit (dBm)	Margin (dB)
1792.025	-48.29	-50.00	H	5.43	-44.57	-20.00	24.57
1792.025	-47.78	-52	V	5.30	-46.70	-20.00	26.70
2688.0375	-52.78	-53	H	5.61	-47.39	-20.00	27.39
2688.0375	-52.86	-55	V	5.83	-49.17	-20.00	29.17
3584.05	-53.9	-53	H	5.92	-47.08	-20.00	27.08
3584.05	-55.39	-58	V	5.89	-52.11	-20.00	32.11
4480.0625	-50.13	-49	H	6.48	-42.52	-20.00	22.52
4480.0625	-45.82	-43	V	6.47	-36.53	-20.00	16.53
5376.075	-54.75	-54	H	5.80	-48.20	-20.00	28.20
5376.075	-51.6	-49	V	5.62	-43.38	-20.00	23.38
6272.0875	-54.37	-54	H	5.84	-48.16	-20.00	28.16
6272.0875	-53.26	-48	V	5.80	-42.20	-20.00	22.20
7168.1	-55.67	-52	H	4.96	-47.04	-20.00	27.04
7168.1	-52.54	-43	V	4.99	-38.01	-20.00	18.01
8064.1125	-55.26	-49	H	5.59	-43.41	-20.00	23.41
8064.1125	-56.58	-49	V	5.59	-43.41	-20.00	23.41
8960.125	-56	-49	H	5.85	-43.15	-20.00	23.15
8960.125	-56.33	-50	V	5.95	-44.05	-20.00	24.05

Table 7.4.2-4: Field Strength of Spurious Emissions – 935.0125MHz – MPass Mode

Frequency (MHz)	Spectrum Analyzer Level (dBm)	Generator Level (dBm)	Antenna Polarity (H/V)	Correction Factors (dB)	Corrected Level (dBm)	Limit (dBm)	Margin (dB)
1870.025	-45.31	-45.00	H	5.50	-39.50	-20.00	19.50
1870.025	-44.27	-42	V	5.42	-36.58	-20.00	16.58
2805.0375	-51.22	-55	H	5.69	-49.31	-20.00	29.31
2805.0375	-51.68	-54	V	5.87	-48.13	-20.00	28.13
3740.05	-54.53	-52	H	5.83	-46.17	-20.00	26.17
3740.05	-52.37	-51	V	5.73	-45.27	-20.00	25.27
4675.0625	-46.37	-41	H	6.32	-34.68	-20.00	14.68
4675.0625	-46.53	-43	V	6.29	-36.71	-20.00	16.71
5610.075	-52.14	-49	H	5.82	-43.18	-20.00	23.18
5610.075	-49.14	-45	V	5.64	-39.36	-20.00	19.36
6545.0875	-52.29	-48	H	5.56	-42.44	-20.00	22.44
6545.0875	-51.94	-42	V	5.56	-36.44	-20.00	16.44
7480.1	-57.19	-53	H	5.18	-47.82	-20.00	27.82
7480.1	-54.68	-46	V	5.27	-40.73	-20.00	20.73
8415.1125	-52.15	-43	H	5.65	-37.35	-20.00	17.35
8415.1125	-52.11	-41	V	5.65	-35.35	-20.00	15.35
9350.125	-57.42	-52	H	6.07	-45.93	-20.00	25.93
9350.125	-57.67	-50	V	6.03	-43.97	-20.00	23.97

PART 101

Table 7.4.2-5: Field Strength of Spurious Emissions – 928.925MHz – Normal Mode

Frequency (MHz)	Spectrum Analyzer Level (dBm)	Generator Level (dBm)	Antenna Polarity (H/V)	Correction Factors (dB)	Corrected Level (dBm)	Limit (dBm)	Margin (dB)
1857.85	-46.50	-47.00	H	5.48	-41.52	-20.00	21.52
1857.85	-45.64	-49	V	5.40	-43.60	-20.00	23.60
2786.775	-51.63	-55	H	5.68	-49.32	-20.00	29.32
2786.775	-52.01	-55	V	5.86	-49.14	-20.00	29.14
3715.7	-54.68	-55	H	5.84	-49.16	-20.00	29.16
3715.7	-52.04	-52	V	5.76	-46.24	-20.00	26.24
4644.625	-47.01	-43	H	6.36	-36.64	-20.00	16.64
4644.625	-48.38	-45	V	6.33	-38.67	-20.00	18.67
5573.55	-51.38	-48	H	5.79	-42.21	-20.00	22.21
5573.55	-47.95	-43	V	5.61	-37.39	-20.00	17.39
6502.475	-54.8	-48	H	5.63	-42.37	-20.00	22.37
6502.475	-53.13	-45	V	5.63	-39.37	-20.00	19.37
7431.4	-56.68	-50	H	5.14	-44.86	-20.00	24.86
7431.4	-54.96	-47	V	5.23	-41.77	-20.00	21.77
8360.325	-54.7	-47	H	5.64	-41.36	-20.00	21.36
8360.325	-52.85	-44	V	5.64	-38.36	-20.00	18.36
9289.25	-57.75	-50	H	6.03	-43.97	-20.00	23.97
9289.25	-57.27	-52	V	6.02	-45.98	-20.00	25.98

Table 7.4.2-6: Field Strength of Spurious Emissions – 932.25MHz – Normal Mode

Frequency (MHz)	Spectrum Analyzer Level (dBm)	Generator Level (dBm)	Antenna Polarity (H/V)	Correction Factors (dB)	Corrected Level (dBm)	Limit (dBm)	Margin (dB)
1864.5	-45.59	-44.00	H	5.49	-38.51	-20.00	18.51
1864.5	-44.85	-43	V	5.41	-37.59	-20.00	17.59
2796.75	-51.27	-55	H	5.68	-49.32	-20.00	29.32
2796.75	-52.24	-55	V	5.86	-49.14	-20.00	29.14
3729	-54.86	-53	H	5.84	-47.16	-20.00	27.16
3729	-51.91	-52	V	5.75	-46.25	-20.00	26.25
4661.25	-47.52	-43	H	6.34	-36.66	-20.00	16.66
4661.25	-46.25	-42	V	6.31	-35.69	-20.00	15.69
5593.5	-50.13	-47	H	5.81	-41.19	-20.00	21.19
5593.5	-47.39	-42	V	5.63	-36.37	-20.00	16.37
6525.75	-53.36	-46	H	5.59	-40.41	-20.00	20.41
6525.75	-51.33	-43	V	5.59	-37.41	-20.00	17.41
7458	-56.13	-49	H	5.16	-43.84	-20.00	23.84
7458	-57.12	-50	V	5.25	-44.75	-20.00	24.75
8390.25	-50.31	-38	H	5.64	-32.36	-20.00	12.36
8390.25	-52.32	-41	V	5.64	-35.36	-20.00	15.36
9322.5	-57.52	-54	H	6.05	-47.95	-20.00	27.95
9322.5	-58.08	-55	V	6.02	-48.98	-20.00	28.98

Table 7.4.2-7: Field Strength of Spurious Emissions – 941.4875MHz – MPass Mode

Frequency (MHz)	Spectrum Analyzer Level (dBm)	Generator Level (dBm)	Antenna Polarity (H/V)	Correction Factors (dB)	Corrected Level (dBm)	Limit (dBm)	Margin (dB)
1882.975	-44.42	-46.00	H	5.51	-40.49	-20.00	20.49
1882.975	-43.71	-44	V	5.44	-38.56	-20.00	18.56
2824.4625	-49.83	-52	H	5.70	-46.30	-20.00	26.30
2824.4625	-51.33	-54	V	5.87	-48.13	-20.00	28.13
3765.95	-53.41	-52	H	5.82	-46.18	-20.00	26.18
3765.95	-51.99	-52	V	5.71	-46.29	-20.00	26.29
4707.4375	-46.65	-42	H	6.29	-35.71	-20.00	15.71
4707.4375	-45.87	-43	V	6.25	-36.75	-20.00	16.75
5648.925	-51.68	-48	H	5.85	-42.15	-20.00	22.15
5648.925	-48.13	-42	V	5.68	-36.32	-20.00	16.32
6590.4125	-51.88	-44	H	5.49	-38.51	-20.00	18.51
6590.4125	-50.39	-42	V	5.49	-36.51	-20.00	16.51
7531.9	-56.76	-50	H	5.21	-44.79	-20.00	24.79
7531.9	-55.52	-49	V	5.31	-43.69	-20.00	23.69
8473.3875	-48.68	-35	H	5.66	-29.34	-20.00	9.34
8473.3875	-49.01	-37	V	5.66	-31.34	-20.00	11.34
9414.875	-55.57	-47	H	6.10	-40.90	-20.00	20.90
9414.875	-57.6	-52	V	6.04	-45.96	-20.00	25.96

Table 7.4.2-8: Field Strength of Spurious Emissions – 959.925MHz – MPass Mode

Frequency (MHz)	Spectrum Analyzer Level (dBm)	Generator Level (dBm)	Antenna Polarity (H/V)	Correction Factors (dB)	Corrected Level (dBm)	Limit (dBm)	Margin (dB)
1919.85	-41.47	-46.00	H	5.54	-40.46	-20.00	20.46
1919.85	-44.32	-44	V	5.49	-38.51	-20.00	18.51
2879.775	-52.34	-57	H	5.74	-51.26	-20.00	31.26
2879.775	-51.25	-55	V	5.89	-49.11	-20.00	29.11
3839.7	-53.56	-53	H	5.77	-47.23	-20.00	27.23
3839.7	-55.49	-57	V	5.64	-51.36	-20.00	31.36
4799.625	-48.68	-44	H	6.19	-37.81	-20.00	17.81
4799.625	-47.49	-43	V	6.13	-36.87	-20.00	16.87
5759.55	-52.75	-49	H	5.93	-43.07	-20.00	23.07
5759.55	-50.11	-48	V	5.78	-42.22	-20.00	22.22
6719.475	-53.74	-44	H	5.28	-38.72	-20.00	18.72
6719.475	-50.89	-41	V	5.28	-35.72	-20.00	15.72
7679.4	-56.61	-49	H	5.33	-43.67	-20.00	23.67
7679.4	-55.46	-48	V	5.39	-42.61	-20.00	22.61
8639.325	-49.19	-35	H	5.72	-29.28	-20.00	9.28
8639.325	-49.5	-38	V	5.75	-32.25	-20.00	12.25
9599.25	-56.79	-46	H	6.16	-39.84	-20.00	19.84
9599.25	-57.85	-55	V	6.06	-48.94	-20.00	28.94

7.5 Frequency Stability - FCC Section 2.1055, 24.135, 90.213, 101.107

7.5.1 Measurement Procedure

The equipment under test is placed inside an environmental chamber. The RF output is directly coupled to the input of the measurement equipment and a power supply is attached to the primary supply voltage.

Frequency measurements were made at the extremes of the of temperature range -30° C to +50° C and at intervals of 10° C at normal supply voltage. A period of time sufficient to stabilize all components of the equipment was allowed at each frequency measurement. At a temperature 20° C the supply voltage was varied from 85% to 115% from the normal. The maximum variation of frequency was recorded.

Data was collected at frequencies according to Section 1.3.2. Results of the test are shown below in Figures 7.5.2-1 through 7.5.2-8.

7.5.2 Measurement Results

PART 24

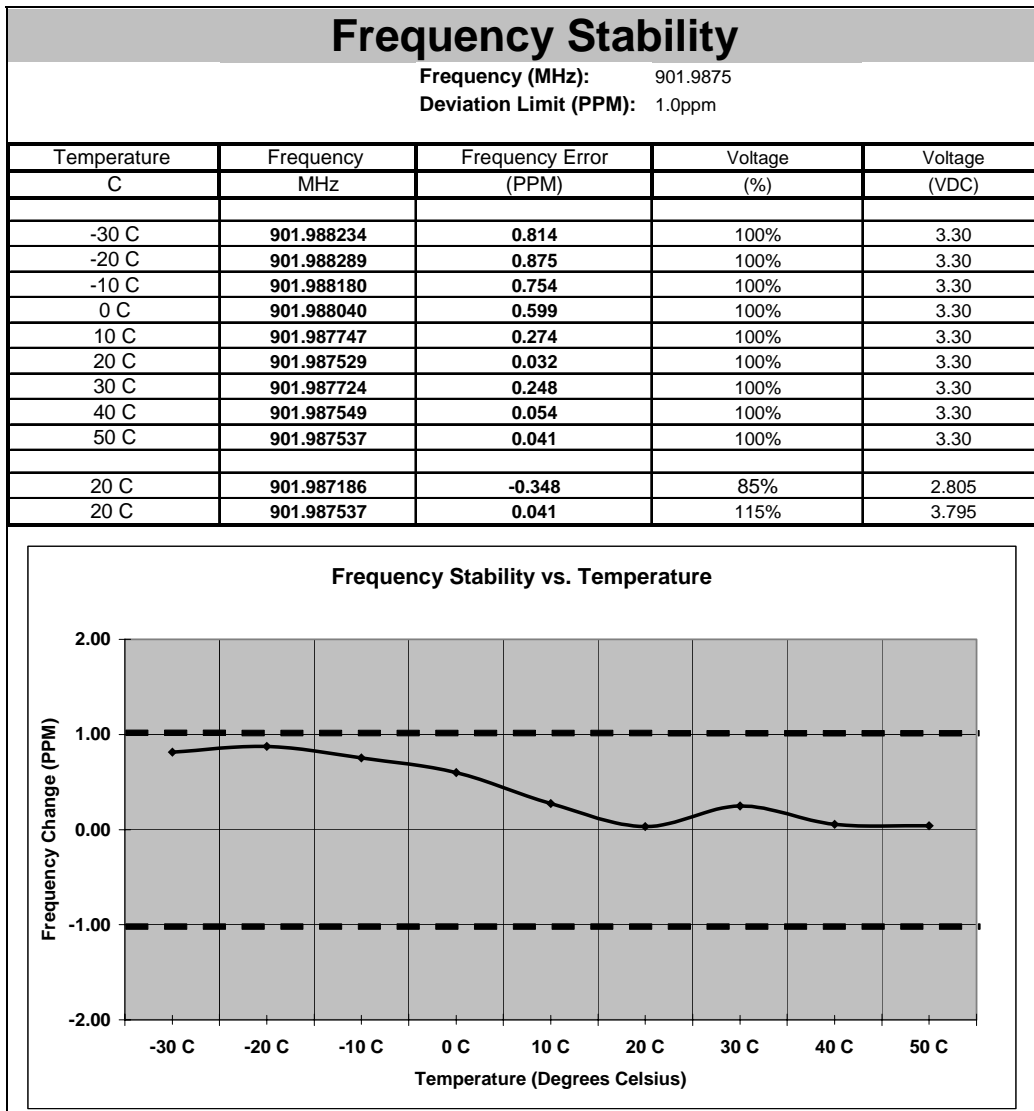
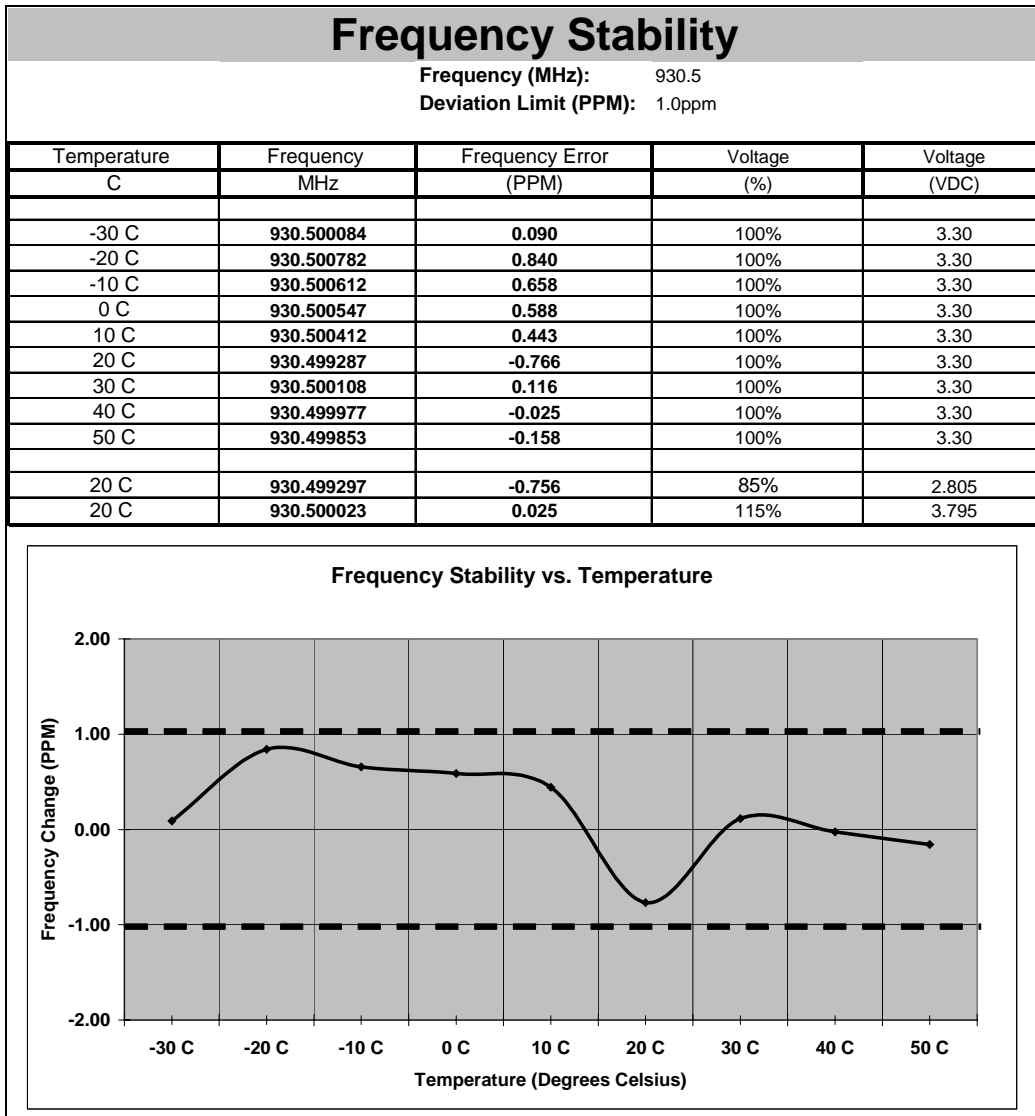

Figure 7.5.2-1: Frequency Stability – 901.9875MHz



PART 90

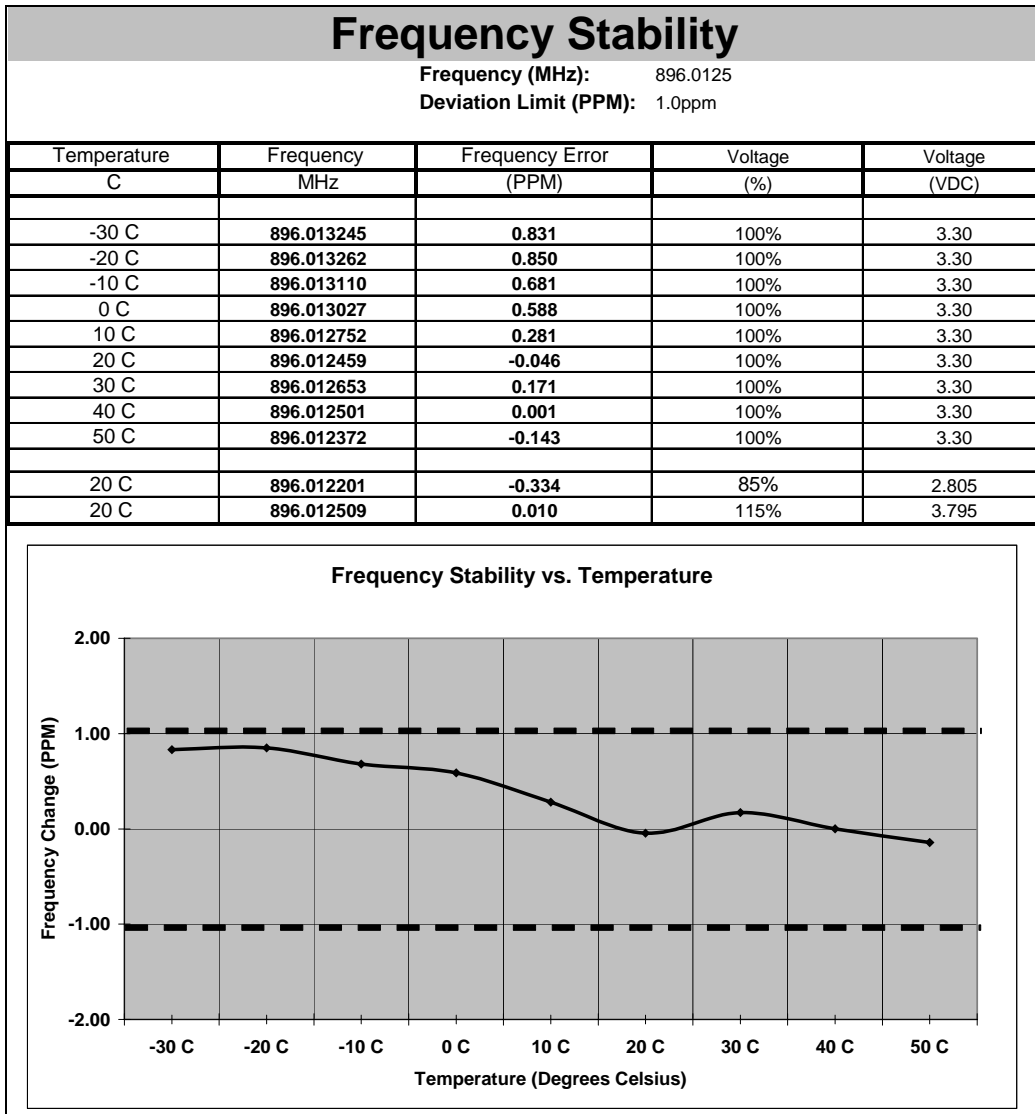

Figure 7.5.2-3: Frequency Stability – 896.0125MHz

Frequency Stability

Frequency (MHz): 935.0125
 Deviation Limit (PPM): 1.0ppm

Temperature C	Frequency MHz	Frequency Error (PPM)	Voltage (%)	Voltage (VDC)
-30 C	935.012618	0.126	100%	3.30
-20 C	935.013262	0.815	100%	3.30
-10 C	935.013087	0.628	100%	3.30
0 C	935.013043	0.581	100%	3.30
10 C	935.012867	0.393	100%	3.30
20 C	935.012500	0.000	100%	3.30
30 C	935.012582	0.088	100%	3.30
40 C	935.012466	-0.036	100%	3.30
50 C	935.012324	-0.188	100%	3.30
20 C	935.011830	-0.717	85%	2.805
20 C	935.012564	0.068	115%	3.795

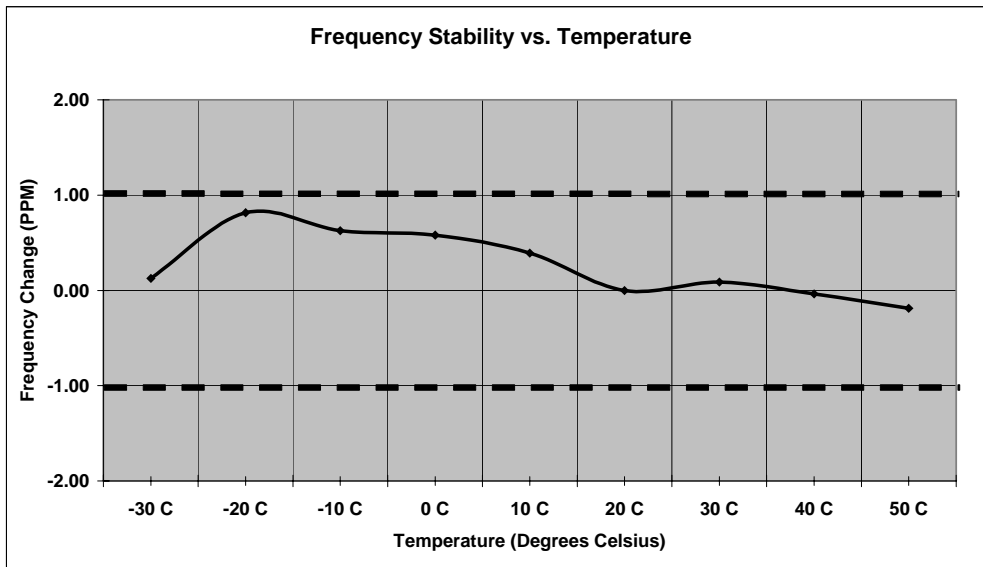

Figure 7.5.2-4: Frequency Stability – 935.0125MHz

PART 101

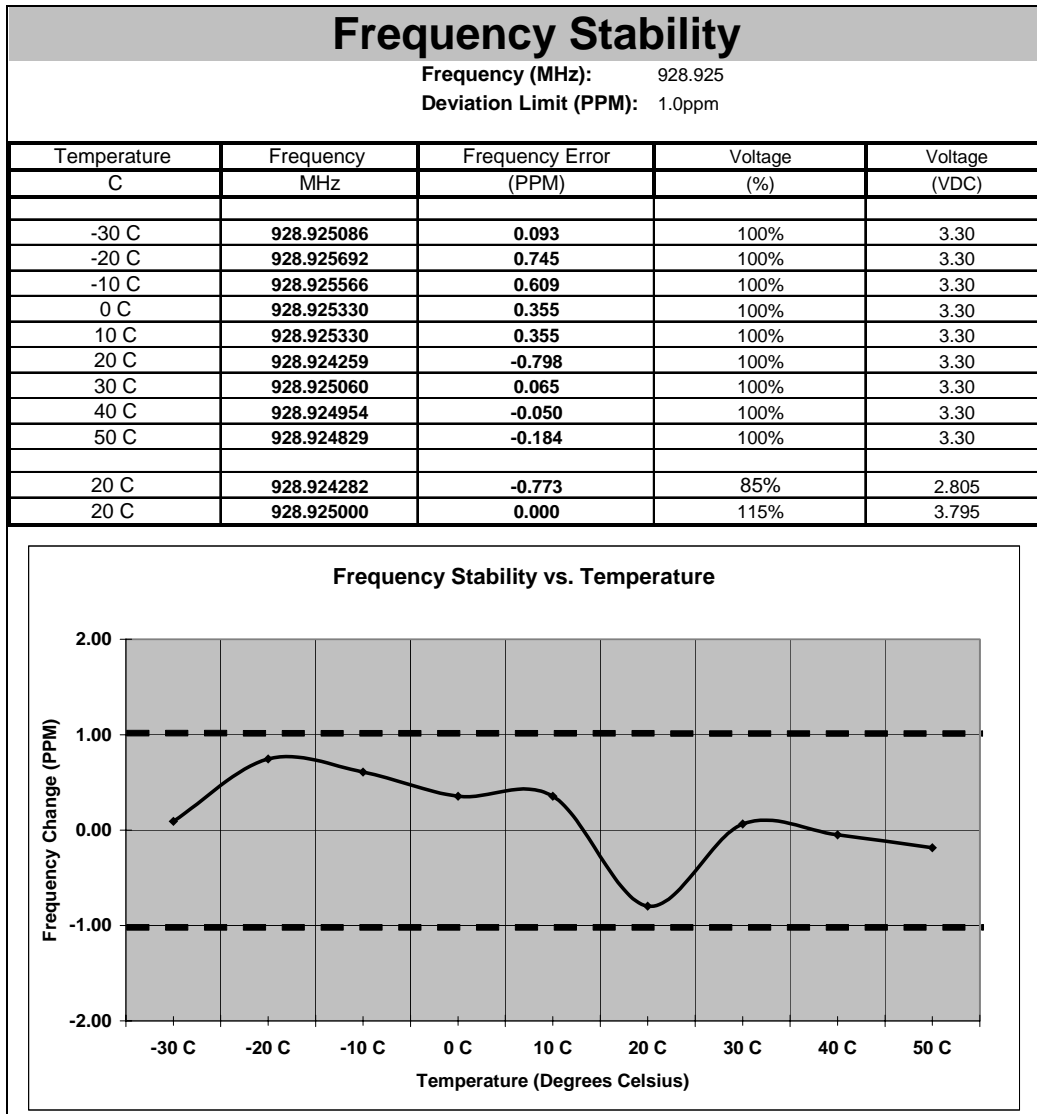

Figure 7.5.2-5: Frequency Stability – 928.925MHz

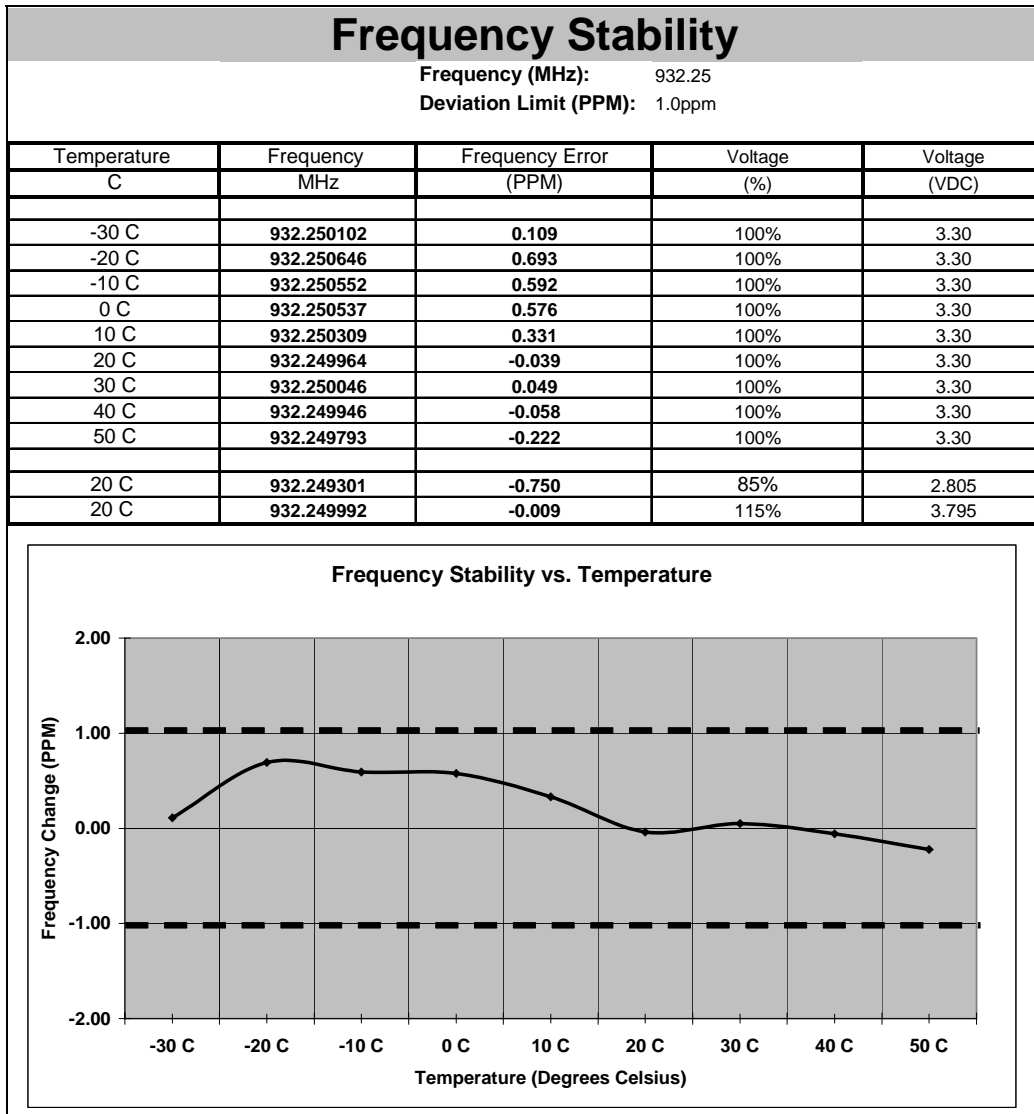

Figure 7.5.2-6: Frequency Stability – 932.5MHz

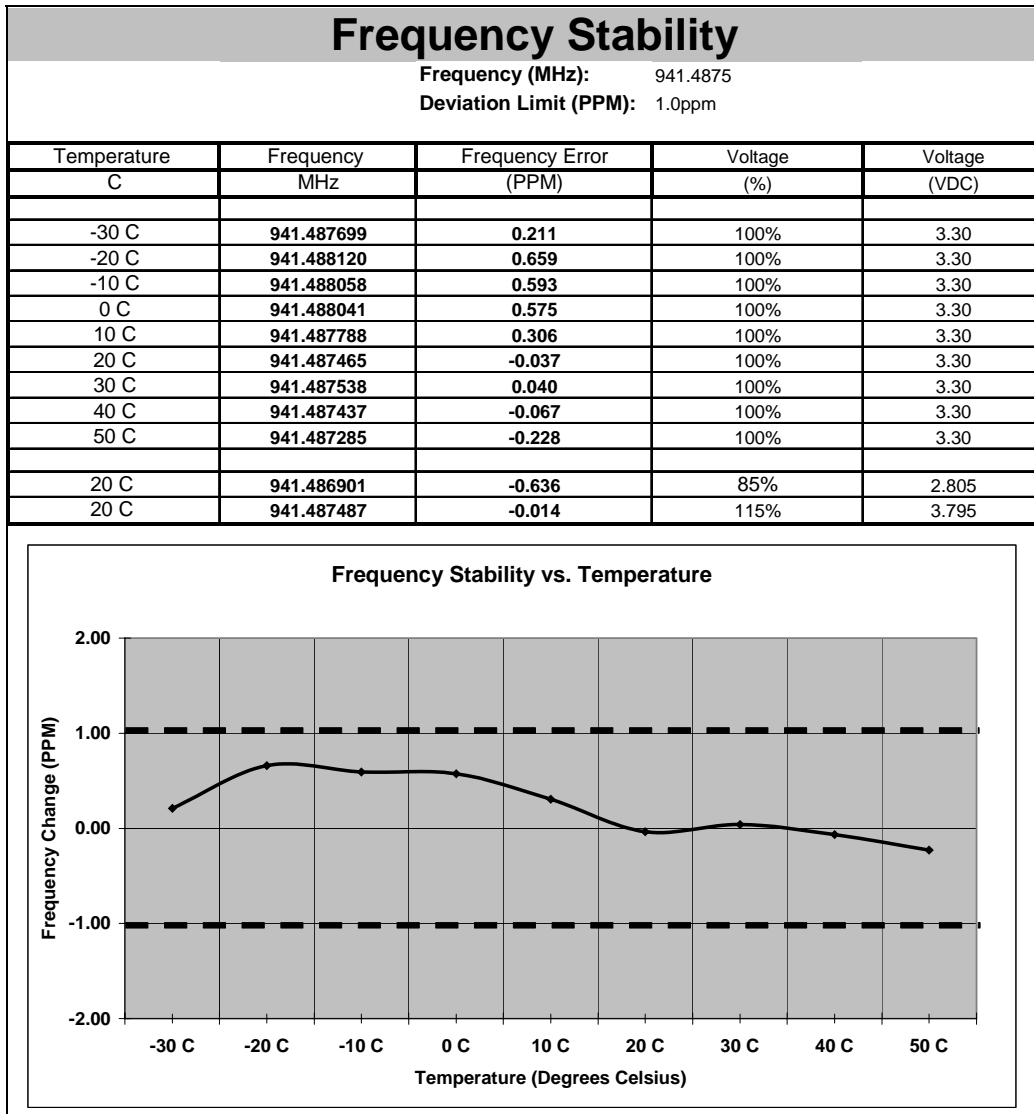

Figure 7.5.2-7: Frequency Stability – 941.4875MHz

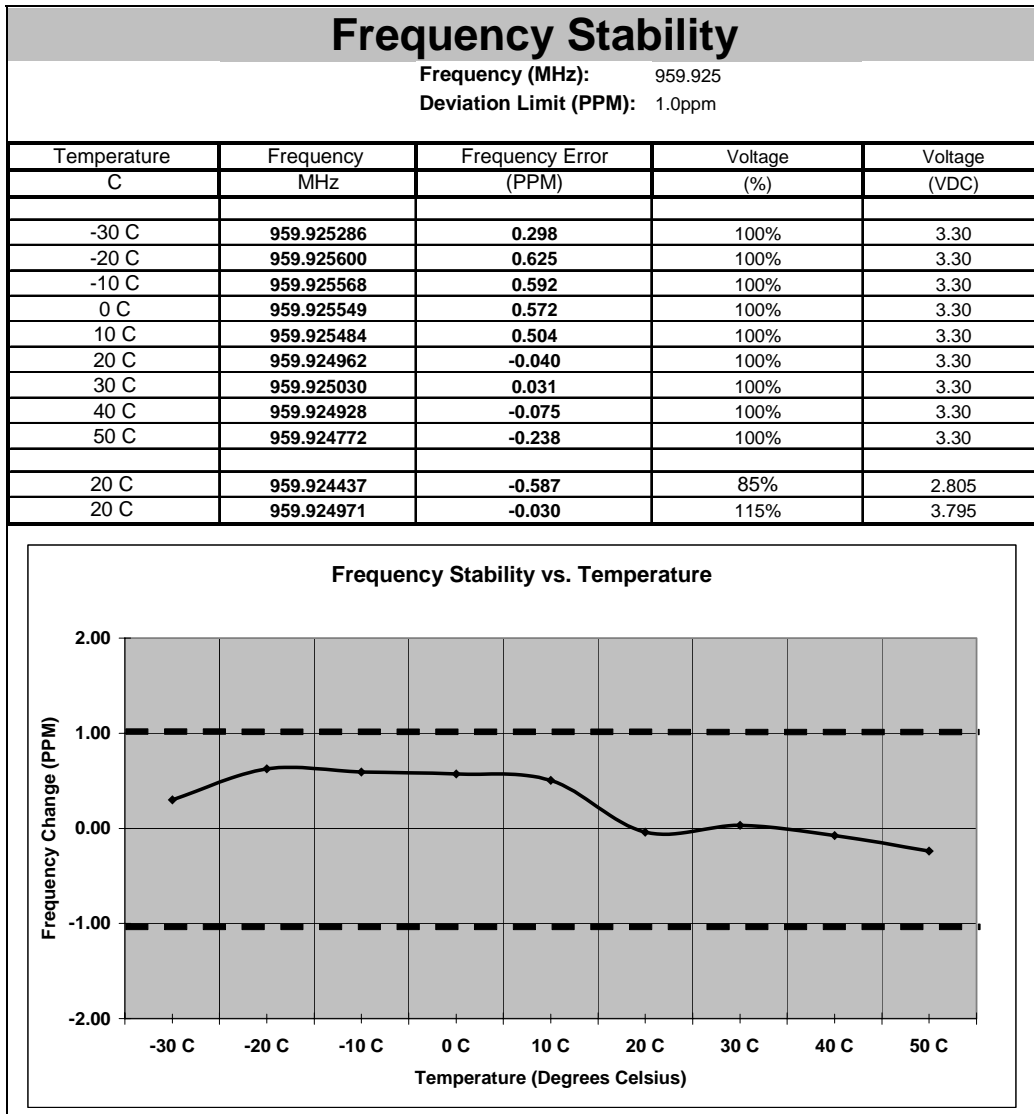

Figure 7.5.2-8: Frequency Stability – 959.925MHz

7.6 Radiated Emissions (Unintentional Radiators) - FCC Section 15.109

7.6.1 Measurement Procedure

The equipment under test is placed in the Semi-Anechoic Chamber (described in section 2.3.1) on a wooden table at the turntable center. For each radiated emission, the antenna mast is raised and lowered from one (1) to four (4) meters and the turntable is rotated 360° to obtain a maximum peak reading on the spectrum analyzer. The radiated emissions are then measured using an EMI receiver employing a CISPR quasi-peak detector for frequencies below 1000 MHz and an Average detector function for frequencies above 1000 MHz. This repeated for both horizontal and vertical polarizations of the receive antenna.

The field strength of each radiated emission is calculated by correcting the EMI receiver level for cable loss, amplifier gain, and antenna correction factors.

$$\text{Field Strength (dBuV/m)} = \text{EMI Receiver Level (dBuV)} + \text{Cable Loss (dB)} - \text{Amplifier Gain (dB)} + \text{Antenna Correction Factor (1/m)}$$

Results of the test are shown below in Table 7.6.2-1.

7.6.2 Measurement Results

Table 7.6.2-1: Radiated Emissions Tabulated Data

Frequency (MHz)	Uncorrected Reading (dBµV/m)	Antenna Polarity (H/V)	Antenna Height (cm)	Turntable Azimuth (°)	Total Correction Factor (dB)	Corrected Reading (dBµV/m)	Limit (dBµV/m)	Margin (dB)
30	20.10	H	400	108	-7.00	13.10	40	26.9
42.32	20.30	V	370	338	-13.20	7.10	40	32.9
84.64	20.50	V	100	0	-17.80	2.70	40	37.3
114.8	20.30	H	180	0	-13.80	6.50	43.5	37.0
147.12	19.80	V	270	0	-13.80	6.00	43.5	37.5
204.96	20.10	V	300	270	-14.10	6.00	43.5	37.5
345.84	20.60	V	100	0	-8.60	12.00	46	34.0
397.68	20.90	H	100	180	-7.40	13.50	46	32.5
684.88	21.90	V	100	180	-2.10	19.80	46	26.2
960	21.70	V	100	0	3.30	25.00	46	21.0

Measurements taken above 960 MHz were below the noise floor of the measurement equipment.

8.0 CONCLUSION

In the opinion of ACS, Inc. the model GCVTF, manufactured by Sensus, meets all the requirements of FCC Part 24, 90, and 101 as applicable.

End Report