

Transmitter Certification

Test Report

FCC ID: SDB520X

FCC Rule Part: CFR 47 Part 24 Subpart D, Part 90 Subpart I, Part 101 Subpart C

ACS Report Number: 06-0147-LD

Applicant: Advanced Metering Data Systems, LLC

Equipment Type: Water Meter Data Transmitter

Trade Name: Flexnet

Model(s): 510, 520

Test Begin Date: April 24, 2006

Test End Date: April 26, 2006

Report Issue Date: May 1, 2006



FOR THE SCOPE OF ACCREDITATION UNDER LAB Code 200612

Prepared by: 
J. Kirby Munroe
Manager Wireless Certifications
ACS, Inc.

Reviewed by: 
R. Sam Wismer
Engineering Manager
ACS, Inc.

This test report shall not be reproduced except in full. This report may be reproduced in part with prior written consent of ACS, Inc. The results contained in this report are representative of the sample(s) submitted for evaluation.

This report contains **31** pages

Table of Contents

1.0 General	3
1.1 Purpose	3
1.2 Product Description	3
1.3 Model Descriptions	3
1.4 Emission Designators	3
2.0 Test Facilities	4
2.1 Location	4
2.2 Laboratory Accreditations/Recognitions/Certifications	4
2.3 Radiated Emissions Test Site Description	4
2.3.1 Semi-Anechoic Chamber Test Site	4
2.3.2 Open Area Tests Site (OATS)	5
2.4 Conducted Emissions Test Site Description	6
3.0 Applicable Standards and References	7
4.0 List of Test Equipment	8
5.0 Support Equipment	9
6.0 EUT Setup and Block Diagram	9
7.0 Summary of Tests	10
7.1 RF Power Output	10
7.1.1 Measurement Procedure	10
7.1.2 Measurement Results	10
7.2 Occupied Bandwidth (Emission Limits)	15
7.2.1 Measurement Procedure	15
7.2.2 Measurement Results	15
7.3 Spurious Emissions at Antenna Terminals	24
7.3.1 Measurement Procedure	24
7.3.2 Measurement Results	24
7.4 Field Strength of Spurious Emissions	27
7.4.1 Measurement Procedure	27
7.4.2 Measurement Results	27
7.5 Frequency Stability	29
7.5.1 Measurement Procedure	29
7.5.2 Measurement Results	29
7.6 Radiated Emissions (Unintentional Radiators)	31
7.6.1 Measurement Procedure	31
7.6.2 Measurement Results	31
7.7 Power Line Conducted Emissions	31
7.7.1 Measurement Procedure	31
8.0 Conclusion	31

Additional Exhibits Included In Filing

Internal Photographs
Test Setup Photographs
RF Exposure – MPE Calculations
System Block Diagram
Parts List
Tune-up Procedure

External Photographs
Product Labeling
Installation/Users Guide
Theory of Operation
Schematics

1.0 GENERAL

1.1 Purpose

The purpose of this report is to demonstrate compliance with Part 2 Subpart J, Part 24 Subpart D, Part 90 Subpart I, and Part 101 Subpart C of the FCC's Code of Federal Regulations.

1.2 Product Description

The Sensus models 510 and 520 are comprised of the Sensus AMDS 520X Transmitter (520X). The Sensus AMDS 520X Transmitter (520X) is a printed circuit board that provides wireless communication capability to Sensus 510 and 520 water meter products. These devices monitor readings and diagnostic information collected from commercial and residential water meters via industry standard switch closure or serial data interfaces. The 510 and 520 communicate via the AMDS fixed wireless telemetry network to provide meter readings and diagnostic data from the water meters to the utility provider via a radio link. The 510 and 520 are battery operated and utilize a printed circuit board antenna that is integral to the 520X circuit board.

The 510 and 520 operate on both licensed and unlicensed frequency bands. The licensed frequency bands are 901-902 MHz, 930-931 MHz, and 940-941 MHz in accordance to Part 24 Narrowband PCS; on 896-901 MHz and 935-940 MHz in accordance to Part 90; and on 928.85-929 MHz, 932-932.5 MHz, 941-941.5 MHz, and 959.85-960 MHz in accordance to Part 101. For the unlicensed operation, the Sensus 510 and 520 also utilizes a host of on board magnetic coupling interfaces that operate under FCC Part 15 Subpart C at 25kHz and 50kHz. The purpose of these magnetic coupling interfaces is to read meter registers and to allow for an external device to interrogate the radio.

The magnetic coupling interfaces are addressed in Part 15 Subpart C of the FCC rules and are therefore covered under separate test report. This report addresses the licensed operation of the 510 and 520 (520X module) only.

1.3 Model Descriptions

The Sensus models 510 and 520 use the identical Sensus AMDS 520X Transmitter (520X) board. The model numbers are used to distinguish between the plastic enclosures and placement of the 25kHz and 50kHz magnetic coupling interfaces coils. The model 510 is designed for applications that are mounted above ground (i.e. inside a basement, against an exterior wall, etc). The model 520 is intended for applications that are mounted inside a "water pit".

See the internal and external photographs for additional details.

1.4 Emission Designators

The Sensus AMDS 520X Transmitter produces four distinct modulation formats. The necessary bandwidth calculations for these formats may be found in a separate document.

The emissions designators for the four modulation types used by the AMDS 520X Transmitter are as follows:

EMISSIONS DESIGNATORS:

Normal Mode:	9K60F2D
Half-Baudrate Mode:	4K80F2D
Boost Mode:	1K10F2D
MPass Mode:	5K90F1D

2.0 TEST FACILITIES

2.1 Location

The radiated and conducted emissions test sites are located at the following address:

Advanced Compliance Solutions
5015 B.U. Bowman Drive
Buford, GA 30518
Phone: (770) 831-8048
Fax: (770) 831-8598

2.2 Laboratory Accreditations/Recognitions/Certifications

The Semi-Anechoic Chamber Test Site, Open Area Test Site (OATS) and Conducted Emissions Site have been fully described, submitted to, and accepted by the FCC, Industry Canada and the Japanese Voluntary Control Council for Interference by information technology equipment. In addition, ACS is compliant to ISO 17025 as certified by the National Institute of Standards and Technology under their National Voluntary Laboratory Accreditation Program. The following certification numbers have been issued in recognition of these accreditations and certifications:

FCC Registration Number: 89450

Industry Canada Lab Code: IC 4175

VCCI Member Number: 1831

- VCCI OATS Registration Number R-1526
- VCCI Conducted Emissions Site Registration Number: C-1608

NVLAP Lab Code: 200612

2.3 Radiated Emissions Test Site Description

2.3.1 Semi-Anechoic Chamber Test Site

The Semi-Anechoic Chamber Test Site consists of a 20' x 30' x 18' shielded enclosure. The chamber is lined with Toyo Ferrite Grid Absorber, model number FFG-1000. The ferrite tile grid is 101 x 101 x 19mm thick and weighs approximately 550 grams. These tiles are mounted on steel panels and installed directly on the inner walls of the chamber.

The turntable is 150cm in diameter and is located 160cm from the back wall of the chamber. The chamber is grounded via 1 - 8' copper ground rod, installed at the center of the back wall, it is bound to the ground plane using 3/4" stainless steel braided cable.

The turntable is all steel, flush mounted table installed in an all steel frame. The table is remotely operated from inside the control room located 25' from the range. The turntable is electrically bonded to the surrounding ground plane via steel fingers installed on the edge of the turn table. The steel fingers make constant contact with the ground plane during operation.

Behind the turntable is a 3' x 6' x 4' deep shielded pit used for support equipment if necessary. The pit is equipped with 1 - 4" PVC chases from the turntable to the pit that allow for cabling to the EUT if necessary. The underside of the turntable can be accessed from the pit so cables can be supplied to the EUT from the pit.

A diagram of the Semi-Anechoic Chamber Test Site is shown in Figure 2.3-1 below:

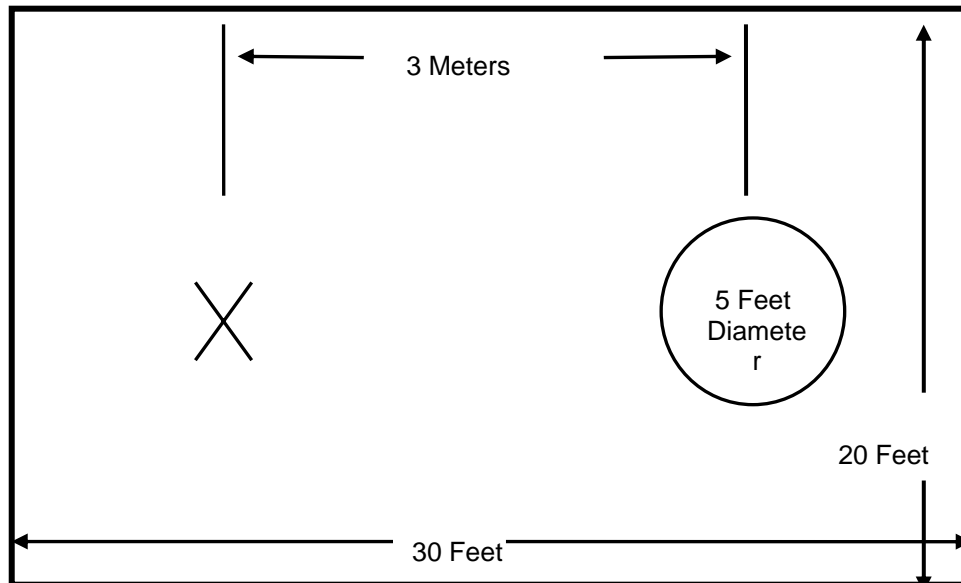

Figure 2.3-1: Semi-Anechoic Chamber Test Site

2.3.2 Open Area Tests Site (OATS)

The open area test site consists of a 40' x 66' concrete pad covered with a perforated electro-plated galvanized sheet metal. The perforations in the sheet metal are 1/8" holes that are staggered every 3/16". The individual sheets are placed to overlap each other by 1/4" and are riveted together to provide a continuous seam. Rivets are spaced every 3" in a 3 x 20 meter perimeter around the antenna mast and EUT area. Rivets in the remaining area are spaced as necessary to properly secure the ground plane and maintain the electrical continuity.

The entire ground plane extends 12' beyond the turntable edge and 16' beyond the antenna mast when set to a 10 meter measurement distance. The ground plane is grounded via 4 - 8' copper ground rods, each installed at a corner of the ground plane and bound to the ground plane using 3/4" stainless steel braided cable.

The turntable is an all aluminum 10' flush mounted table installed in an all aluminum frame. The table is remotely operated from inside the control room located 40' from the range. The turntable is electrically bonded to the surrounding ground plane via steel fingers installed on the edge of the turn table. The steel fingers make constant contact with the ground plane during operation.

Adjacent to the turntable is a 7' x 7' square and 4' deep concrete pit used for support equipment if necessary. The pit is equipped with 5 - 4" PVC chases from the pit to the control room that allow for cabling to the EUT if necessary. The underside of the turntable can be accessed from the pit so cables can be supplied to the EUT from the pit. The pit is covered with 2 sheets of 1/4" diamond style reinforced steel sheets. The sheets are painted to match the perforated steel ground plane; however the underside edges have been masked off to maintain the electrical continuity of the ground plane. All reflecting objects are located outside of the ellipse defined in ANSI C63.4.

A diagram of the Open Area Test Site is shown in Figure 2.3-2 below:

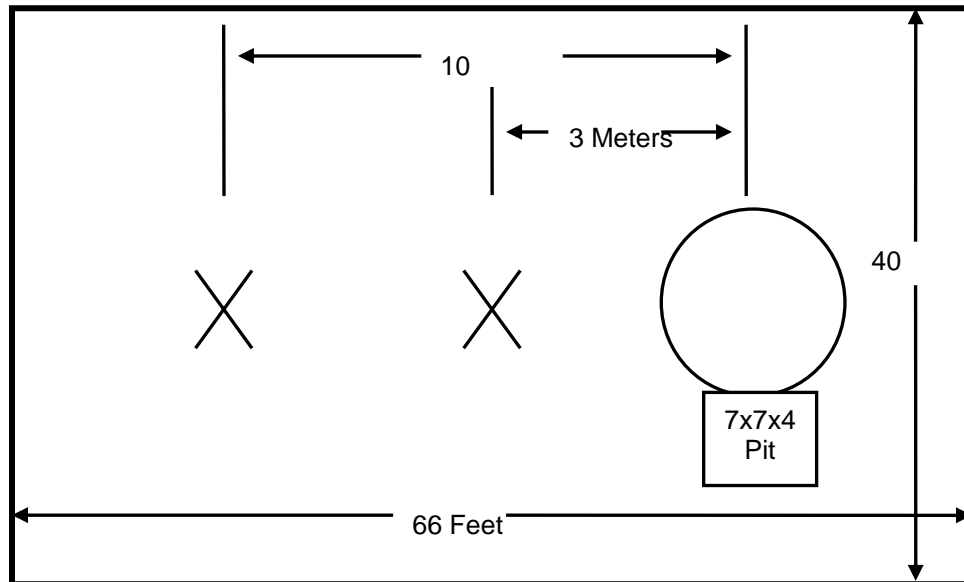

Figure 2.3-2: Open Area Test Site

2.4 Conducted Emissions Test Site Description

The AC mains conducted EMI site is a shielded room with the following dimensions:

- Height: 3.0 Meters
- Width: 3.6 Meters
- Length: 4.9 Meters

The room is manufactured by Rayproof Corporation and installed by Panashield, Inc. Earth ground is provided to the room via an 8' copper ground rod. Each panel of the room is connected electrically at intervals of 4".

Power to the room is filtered to prevent ambient noise from coupling to the EUT and measurement equipment. Filters are models 1B42-60P manufactured by Rayproof Corporation.

The room is of sufficient size to test table top and floor standing equipment in accordance with section 6.1.4 of ANSI C63.4.

A diagram of the room is shown below in figure 2.4-1:

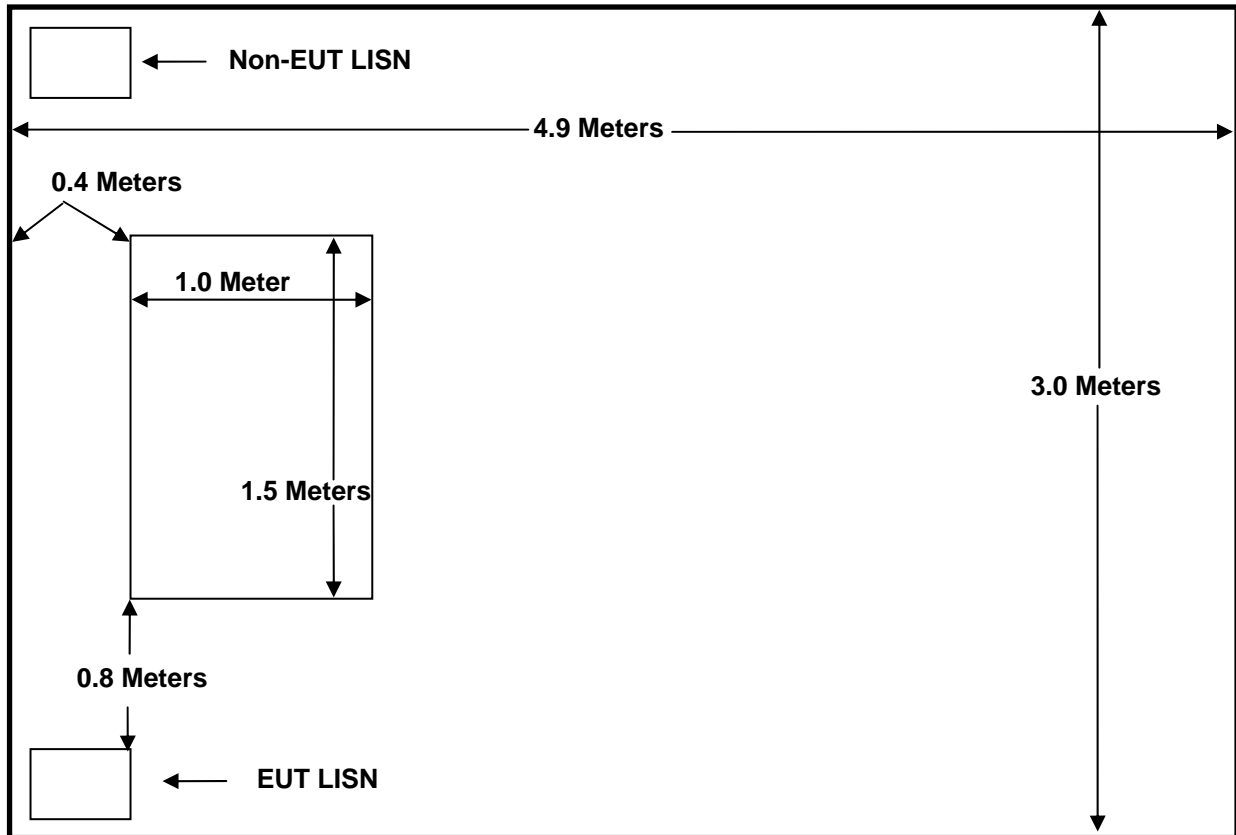

Figure 2.4-1: AC Mains Conducted EMI Site

3.0 APPLICABLE STANDARD REFERENCES

The following standards were used:

- 1 - ANSI C63.4-2003: Method of Measurements of Radio-Noise Emissions from Low-Voltage Electrical and Electronic Equipment in the 9KHz to 40GHz - 2003
- 2 - US Code of Federal Regulations (CFR): Title 47, Part 2, Subpart J: Equipment Authorization Procedures - 2005
- 3 - US Code of Federal Regulations (CFR): Title 47, Part 15, Subpart B: Radio Frequency Devices, Unintentional Radiators - 2005
- 4 - US Code of Federal Regulations (CFR): Title 47, Part 24, Subpart D: Personal Communication Service - 2005
- 5 - US Code of Federal Regulations (CFR): Title 47, Part 90, Subpart I: Private Land Mobile Radio Services - 2005
- 6 - US Code of Federal Regulations (CFR): Title 47, Part 101, Subpart C: Fixed Microwave Services - 2005

4.0 LIST OF TEST EQUIPMENT

All test equipment used for regulatory testing is calibrated yearly or according to manufacturer's specifications.

Table 4-1: Test Equipment

Equipment Calibration Information					
ACS#	Mfg.	Eq. type	Model	S/N	Cal. Due
25	Chase	Bi-Log Antenna	CBL6111	1043	5/23/06
22	Agilent	Pre-Amplifier	8449B	3008A00526	5/06/06
73	Agilent	Pre-Amplifier	8447D	272A05624	5/18/06
30	Spectrum Technologies	Horn Antenna	DRH-0118	970102	5/09/06
---	EMCO	Horn Antenna	3115	9512-4636	N/A
105	Microwave Circuits	High Pass Filter	H1G810G1	2123-01 DC0225	9/13/06
3	Rohde & Schwarz	Receiver Display	804.8932.52	839379/011	11/02/06
4	Rohde & Schwarz	ESMI Receiver	1032.5640.53	833827/003	11/02/06
283	Rohde & Schwarz	Spectrum Analyzer	FSP	100033	3/24/07
6	Harbour Industries	HF RF Cable	LL-335	00006	3/10/07
7	Harbour Industries	HF RF Cable	LL-335	00007	3/13/07
208	Harbour Industries	HF RF Cable	LL142	00208	6/24/06
167	ACS	Chamber EMI Cable Set	RG6	167	1/7/07
237	Gigatronics	Signal Generator	900	282706	1/10/07

5.0 SUPPORT EQUIPMENT

Table 5-1: Support Equipment

Diagram #	Manufacturer	Equipment Type	Model Number	Serial Number	FCC ID
1	Sensus	EUT	510, 520	None	SDB520X
2	OK Industries	DC Power Supply	PS73C	36095	None

6.0 EQUIPMENT UNDER TEST SETUP AND BLOCK DIAGRAM

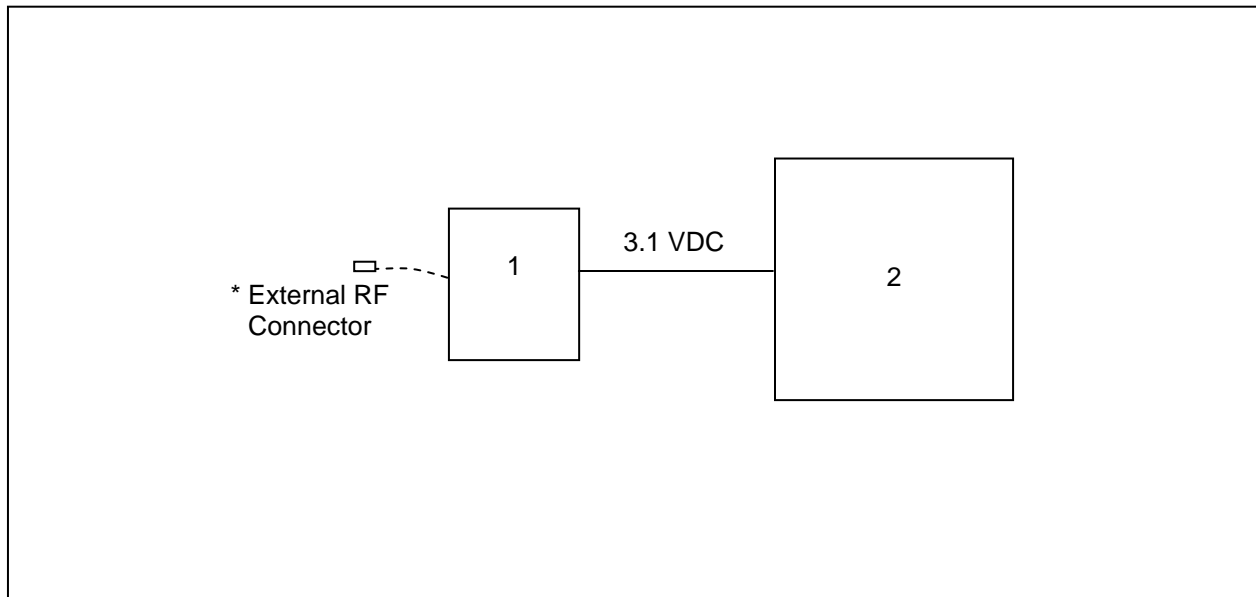

Figure 6-1: EUT Test Setup

For the purpose of testing, the Sensus AMDS 520X Transmitter (520X) board was removed from the Sensus 510 and 520 plastic enclosures. See test setup photographs for additional details.

* For RF conducted and transmitter radiated spurious emissions measurements, the Sensus AMDS 520X Transmitter (520X) was modified with an external RF connector to the PCB. The Sensus AMDS 520X Transmitter (520X) utilizes a printed antenna integral to the transmitter PCB for normal operation but for testing purposes a 50-Ohm test point is available on the PCB. The test point provides proper power level measurements only when the antenna is disconnected and a 50-Ohm test cable is soldered (with the appropriate ground connection) to the PCB. The EUT test cable was connected to non-radiating 50 Ohm load for transmitter radiated measurements.

For the purpose of testing to Part 15 for unintentional radiators, the EUT was test with the integral antenna connected.

7.0 SUMMARY OF TESTS

Along with the tabular data shown below, plots were taken of all signals deemed important enough to document. The most stringent limit from all rule parts indicated in this report was used to show compliance. For example if the spurious emission limit for one rule part is -13 dBm and is -20 dBm for another, the -20 dBm limit is used for spurious emissions for all data points.

7.1 RF Power Output - FCC Section 2.1046

7.1.1 Measurement Procedure

The RF output of the equipment under test was directly connected to the input of the Spectrum Analyzer through a 20 dB passive attenuator. The resolution and video bandwidths of the spectrum analyzer were set at sufficient levels, >> signal bandwidth, to produce accurate results. The internal correction factors of the spectrum analyzer were employed to correct for any cable or attenuator losses. Results are shown below in Table 7.1.2-1 and Figure 7.1.2-1 through 7.1.2-11.

7.1.2 Measurement Results

Table 7.1.2-1: Peak Output Power

Frequency (MHz)	FCC Rule Part	Output Power (dBm)
901.1125	24	31.23
930.1125	24	31.49
940.1125	24	31.43
896.0375	90	31.16
900.9875	90	31.19
935.0125	90	31.48
939.9875	90	31.47
928.93125	101	31.53
932.23125	101	31.50
941.23125	101	31.46
959.9875	101	31.21

Part 24

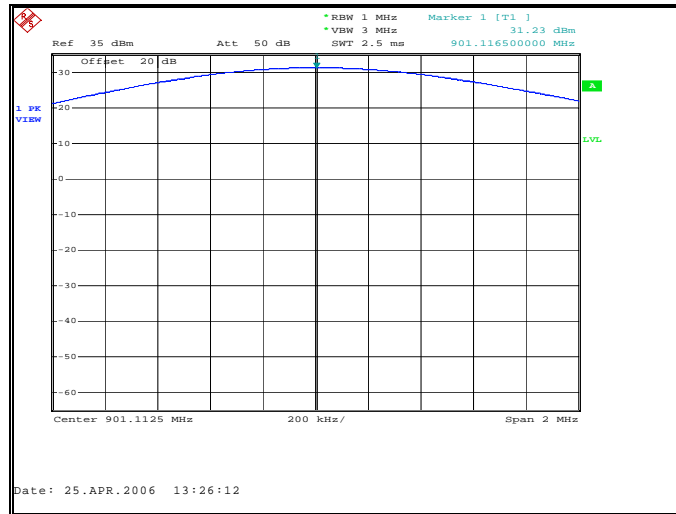

Figure 7.1.2-1: Peak Output Power 901.1125 MHz

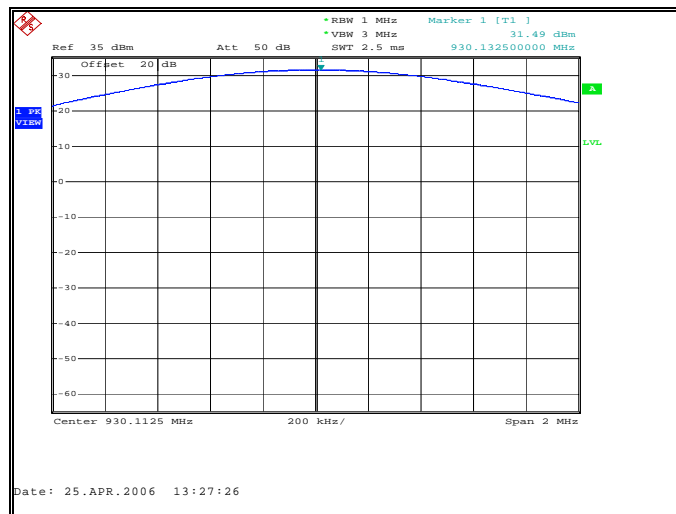

Figure 7.1.2-2: Peak Output Power 930.1125 MHz

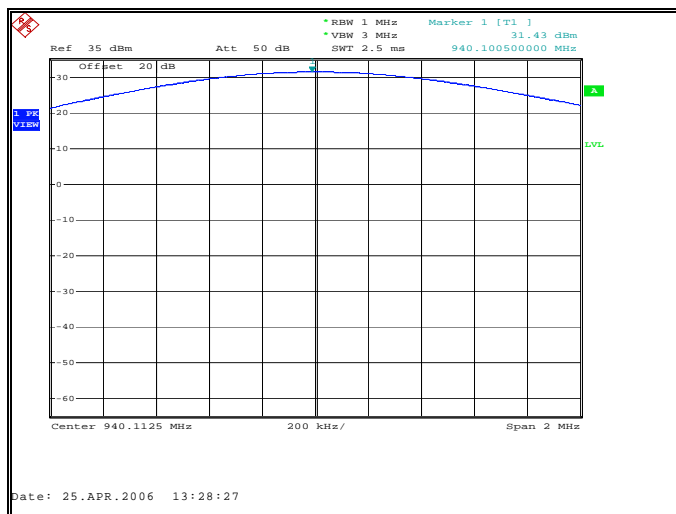

Figure 7.1.2-3: Peak Output Power 940.1125 MHz

Part 90

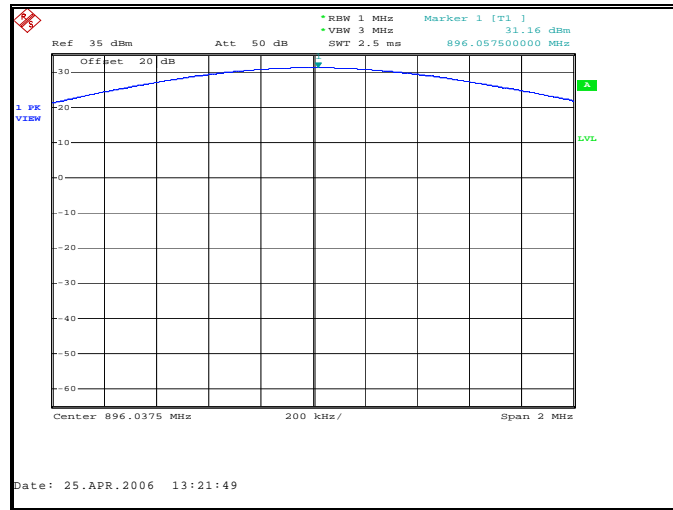

Figure 7.1.2-4: Peak Output Power 896.0375 MHz

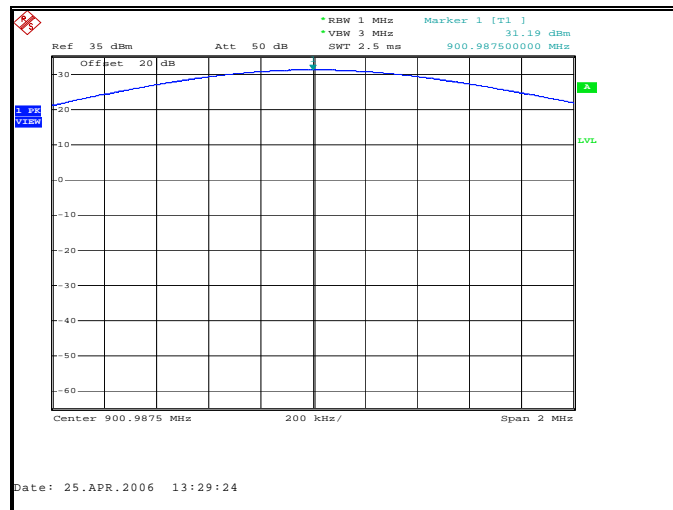

Figure 7.1.2-5: Peak Output Power 900.9875 MHz

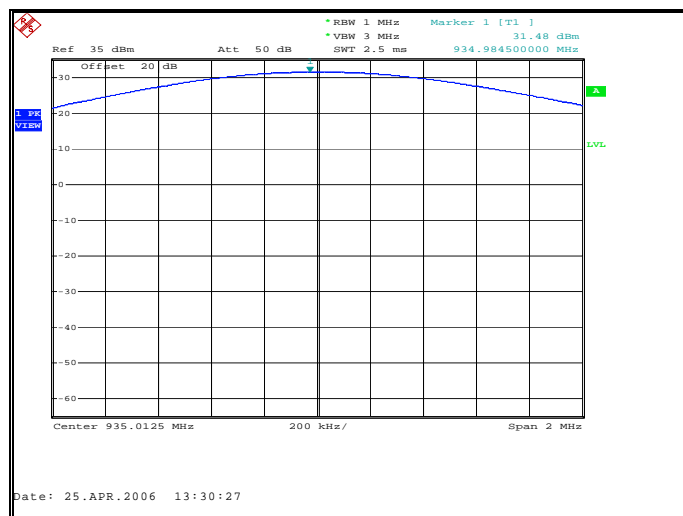

Figure 7.1.2-6: Peak Output Power 935.0125 MHz

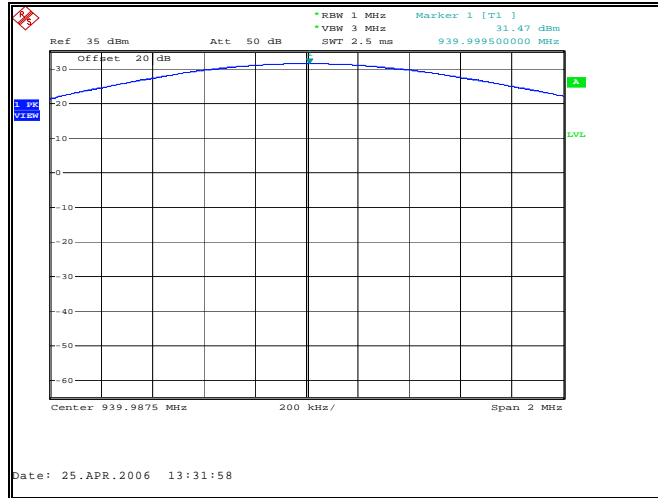

Figure 7.1.2-7: Peak Output Power 939.9875 MHz

Part 101

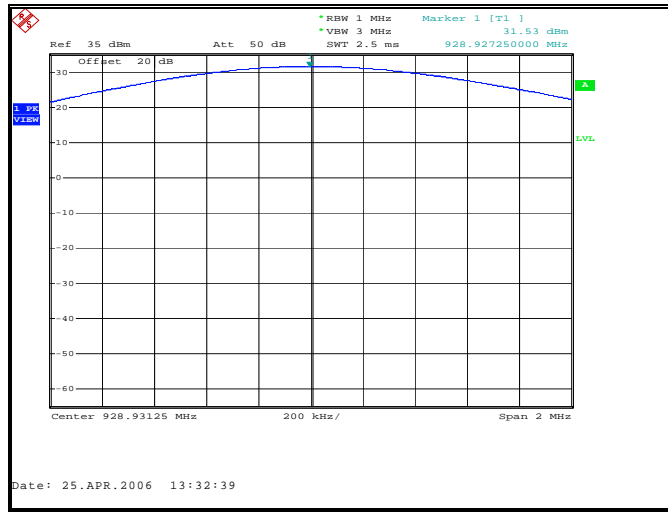

Figure 7.1.2-8: Peak Output Power 928.93125 MHz

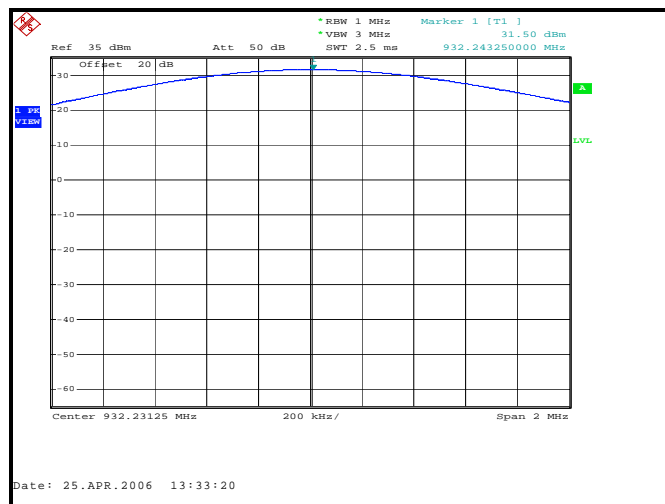

Figure 7.1.2-9: Peak Output Power 932.23125 MHz

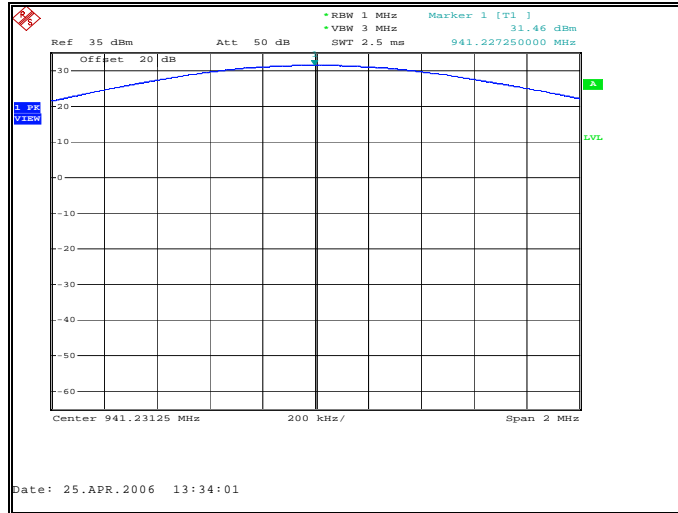

Figure 7.1.2-10: Peak Output Power 941.23125 MHz

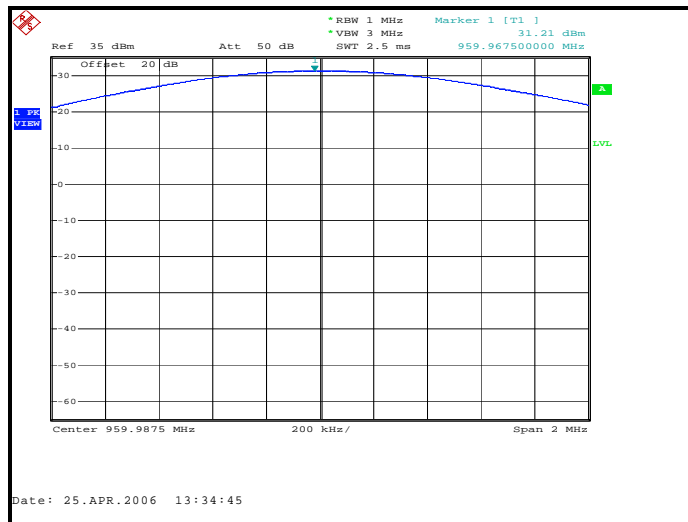

Figure 7.1.2-11: Peak Output Power 959.9875 MHz

7.2 Occupied Bandwidth (Emission Limits) - FCC Section 2.1049

7.2.1 Measurement Procedure

The RF output of the equipment under test was directly connected to the input of the Spectrum Analyzer through a 20 dB passive attenuator. The spectrum analyzer resolution and video bandwidths were set to 300 Hz. The internal correction factors of the spectrum analyzer were employed to correct for any cable or attenuator losses. Results of the test are shown below for all modes of operation.

7.2.2 Measurement Results – Part 24.133 a(1), a(2)

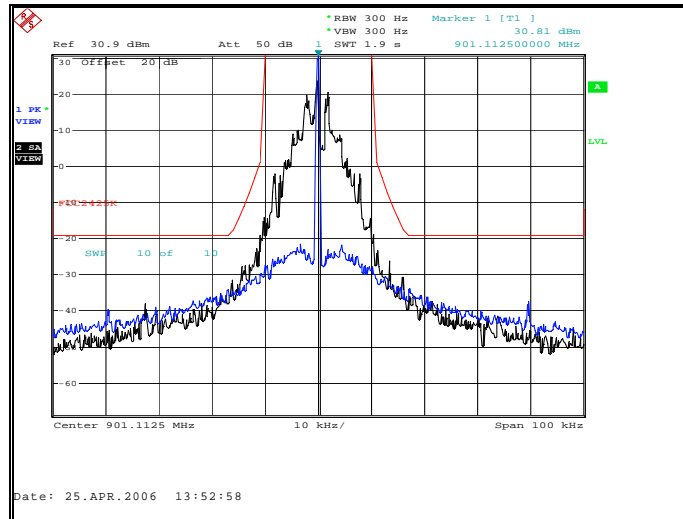

Figure 7.2.2-1: Normal Mode – 901.1125 MHz – 25 kHz Channel

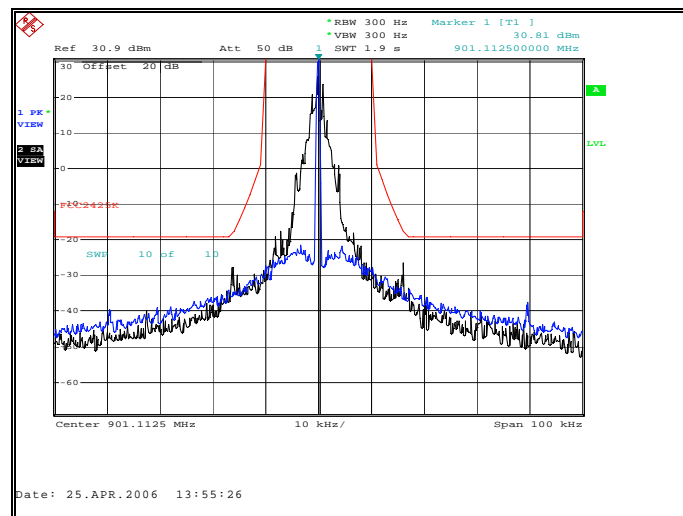

Figure 7.2.2-2: Half-Baud Rate Mode – 901.1125 MHz – 25 kHz Channel

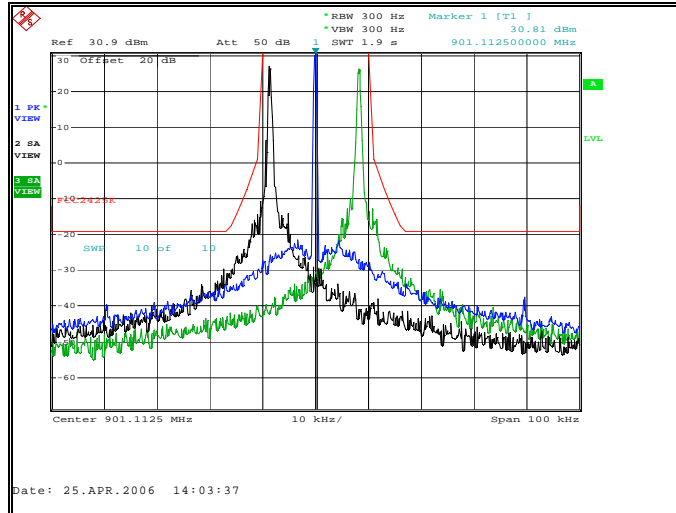

Figure 7.2.2-3: Boost Mode – 901.1125 MHz – 25 kHz Channel
Offset Channel of +/- 14 (+/- 8400 Hz)

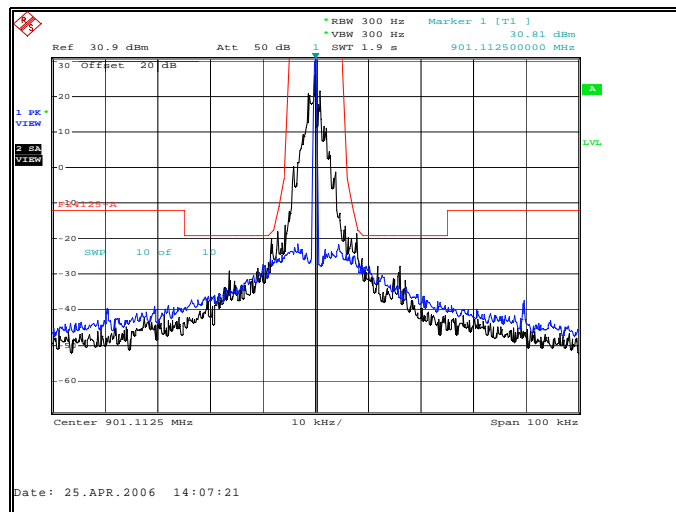

Figure 7.2.2-4: Half-Baud Rate – 901.1125 MHz – 12.5 kHz Channel

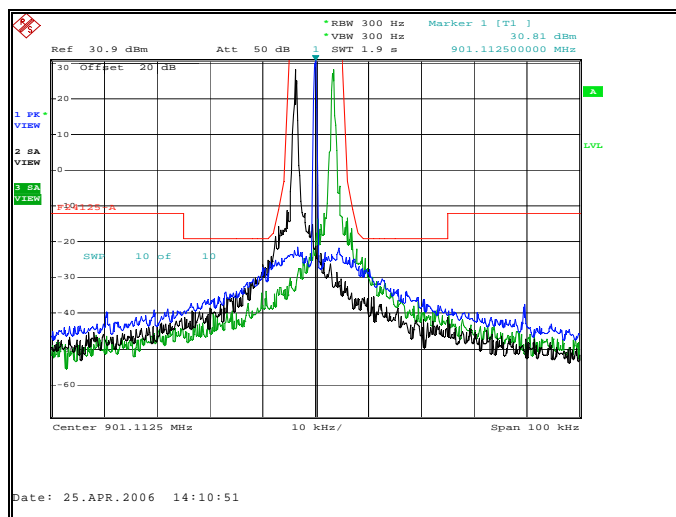

Figure 7.2.2-5: Boost Mode – 901.1125 MHz – 12.5 kHz Channel
Offset Channel of +/- 6 (+/- 3600 Hz)

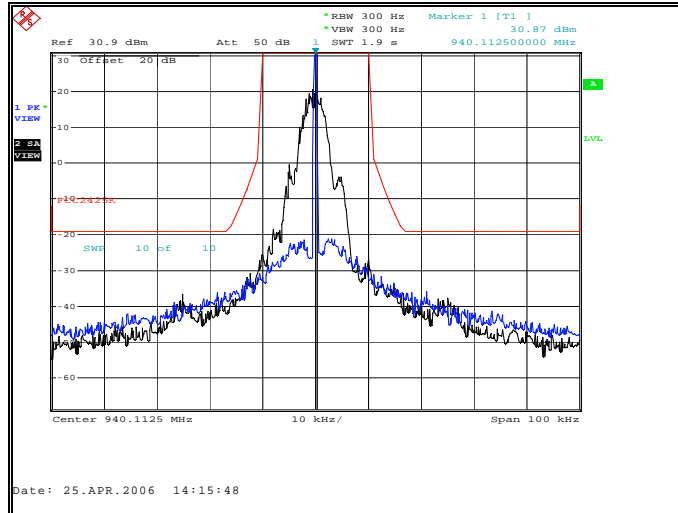

Figure 7.2.2-6: MPass Mode – 940.1125 MHz – 25 kHz Channel

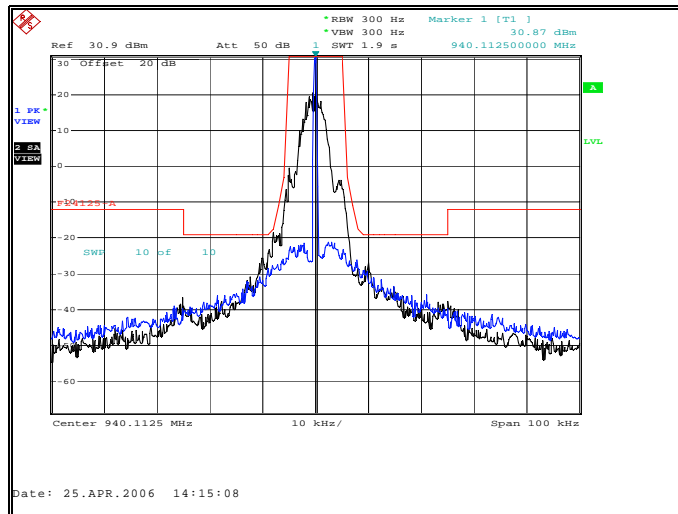

Figure 7.2.2-7: MPass Mode – 940.1125 MHz – 12.5 kHz Channel

7.2.3 Measurement Results – Part 90.210 (j)

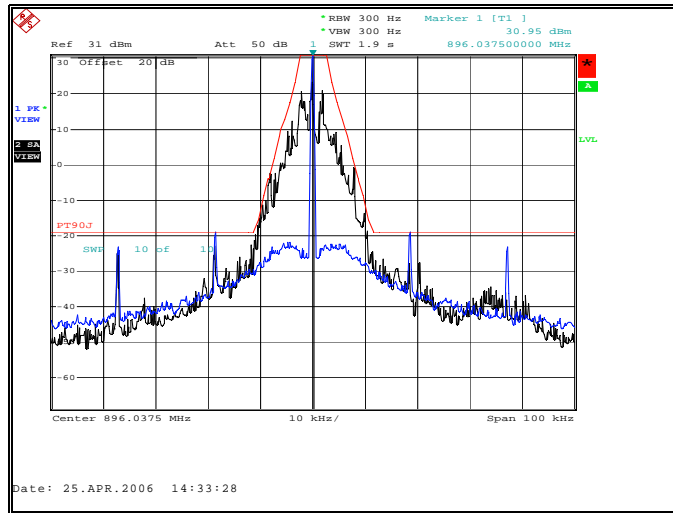

Figure 7.2.3-1: Normal Mode – 896.0375 MHz

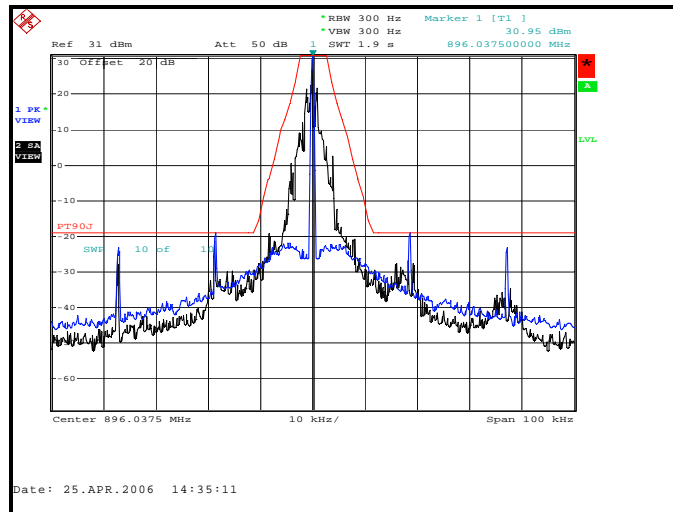

Figure 7.2.3-2: Half-Baud Rate Mode – 896.0375 MHz

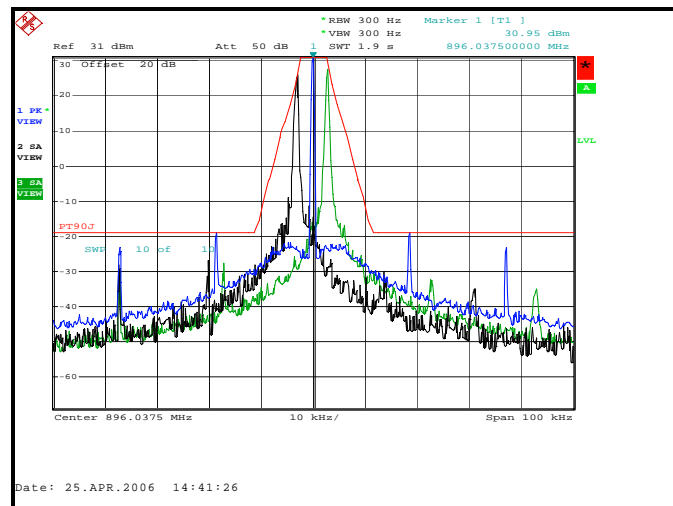

Figure 7.2.3-3: Boost Mode – 896.0375 MHz
Offset Channel of +/- 5 (+/- 3000 Hz)

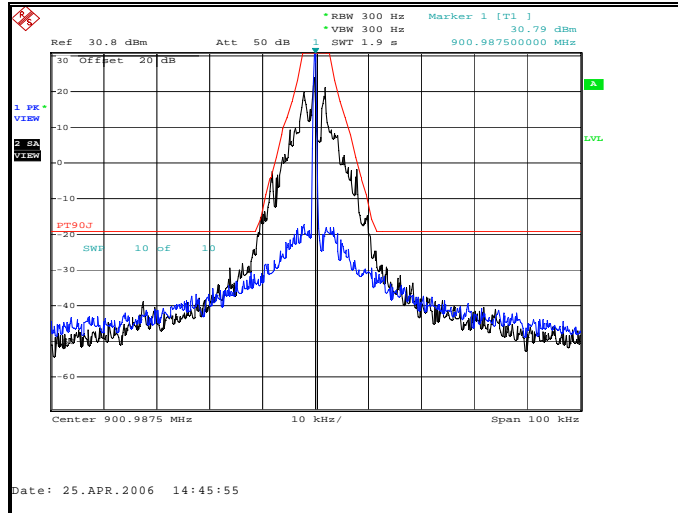

Figure 7.2.3-4: Normal Mode – 900.9875 MHz

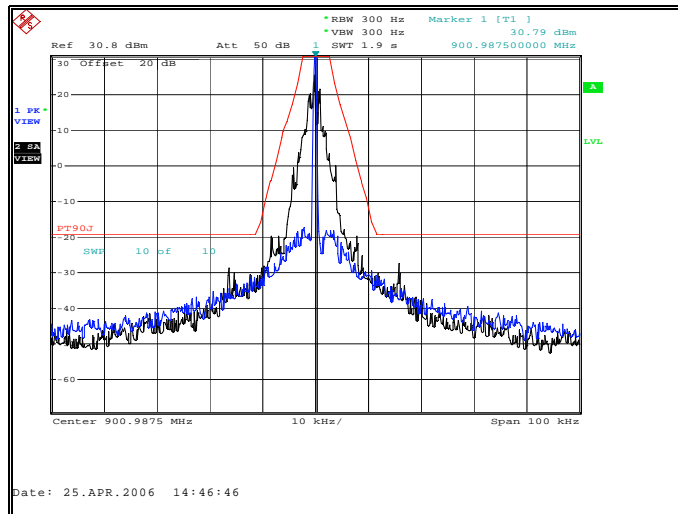

Figure 7.2.3-5: Half-Baud Rate Mode – 900.9875 MHz

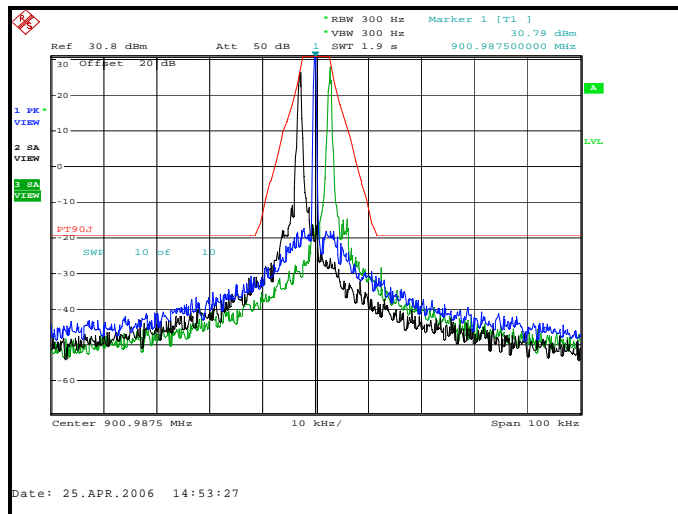

Figure 7.2.3-6: Boost Mode – 900.9875 MHz
Offset Channel of +/- 5 (+/- 3000 Hz)

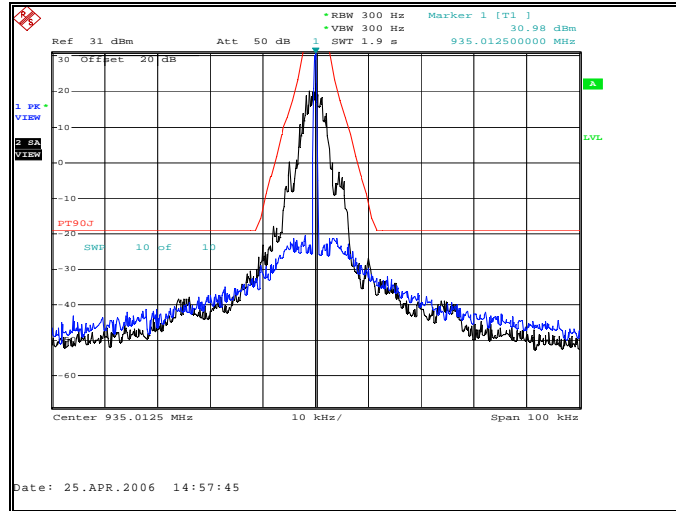

Figure 7.2.3-7: MPass Mode – 935.0125 MHz

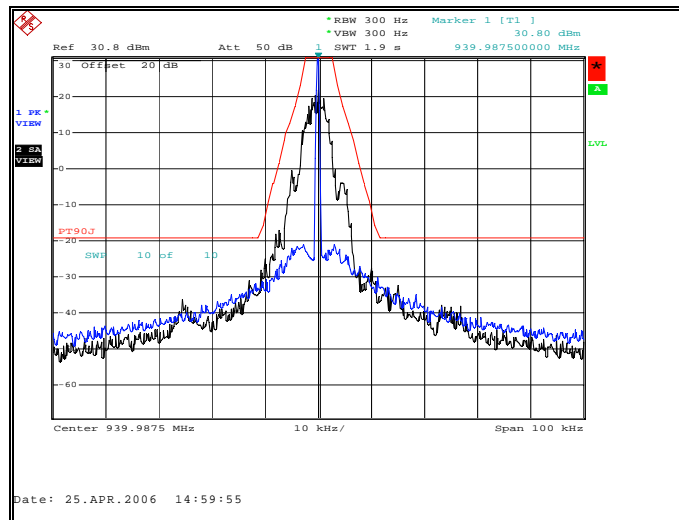

Figure 7.2.3-8: MPass Mode – 939.9875 MHz

7.2.4 Measurement Results – Part 101.111 a(6)

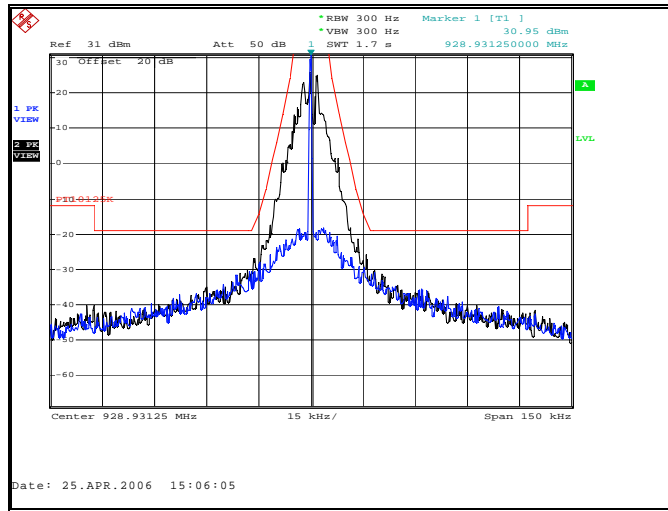

Figure 7.2.4-1: Normal Mode – 928.93125 MHz

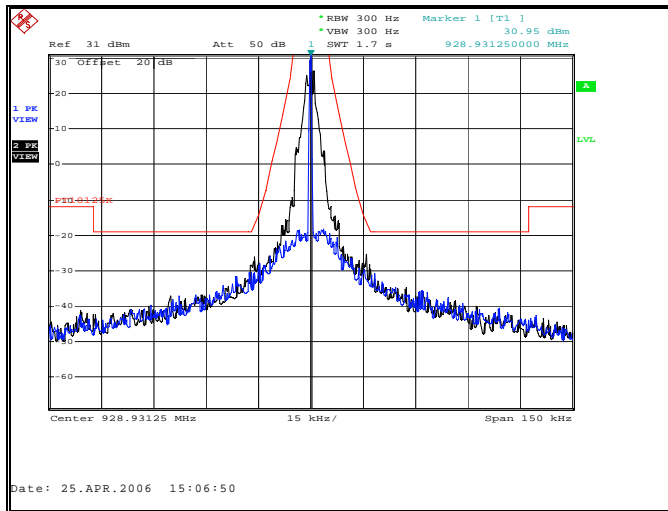

Figure 7.2.4-2: Half-Baud Rate Mode – 928.93125 MHz

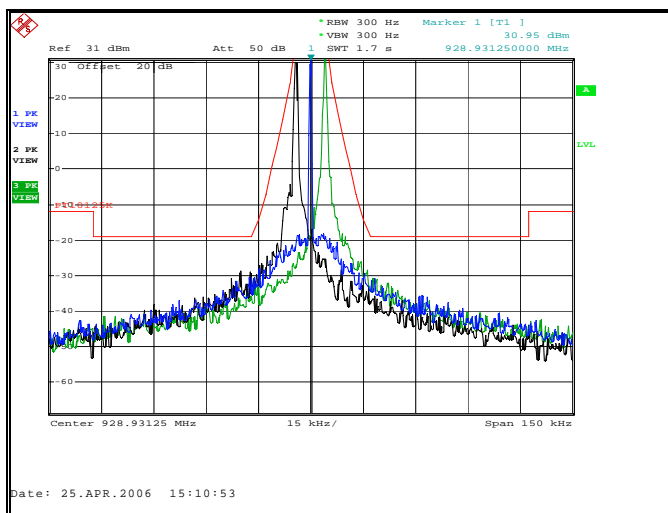

Figure 7.2.4-3: Boost Mode – 928.93125 MHz
Offset Channel of +/- 7 (+/- 4200 Hz)

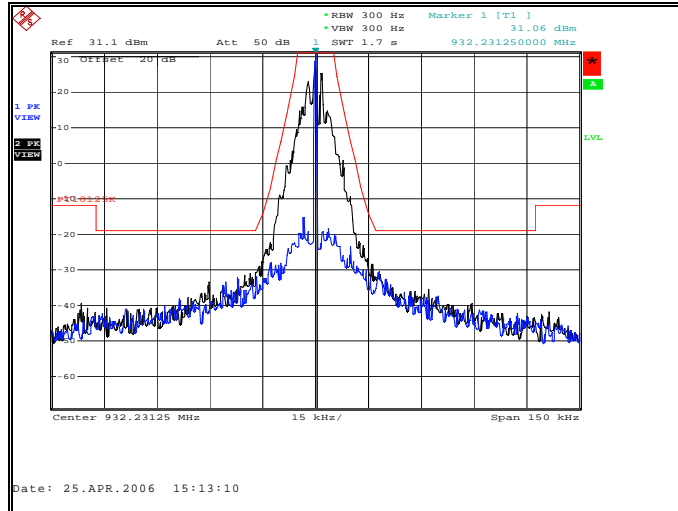

Figure 7.2.4-4: Normal Mode – 932.23125 MHz

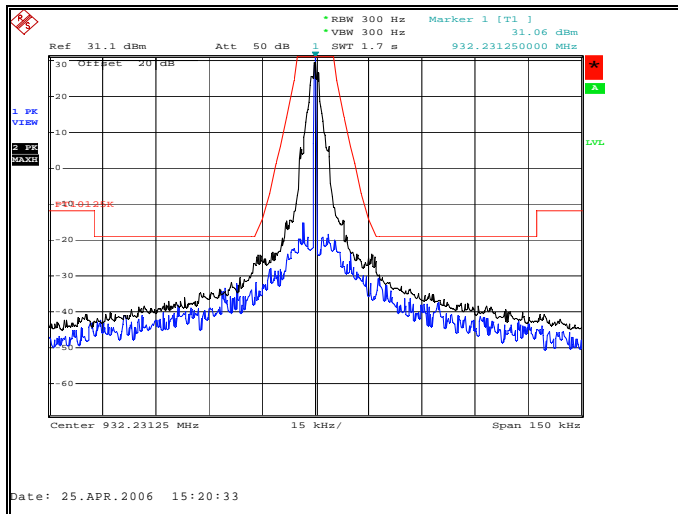

Figure 7.2.4-5: Half-Baud Rate Mode – 932.23125 MHz

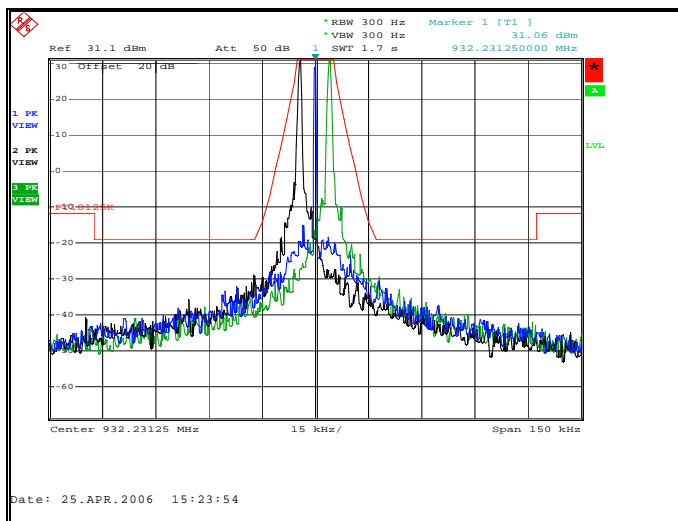

Figure 7.2.4-6: Boost Mode – 932.23125 MHz
Offset Channel of +/- 7 (+/- 4200 Hz)

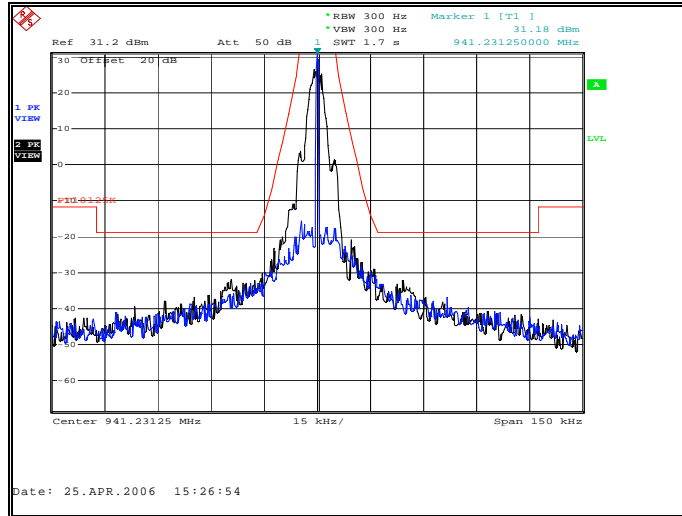

Figure 7.2.4-7: MPass Mode – 941.23125 MHz

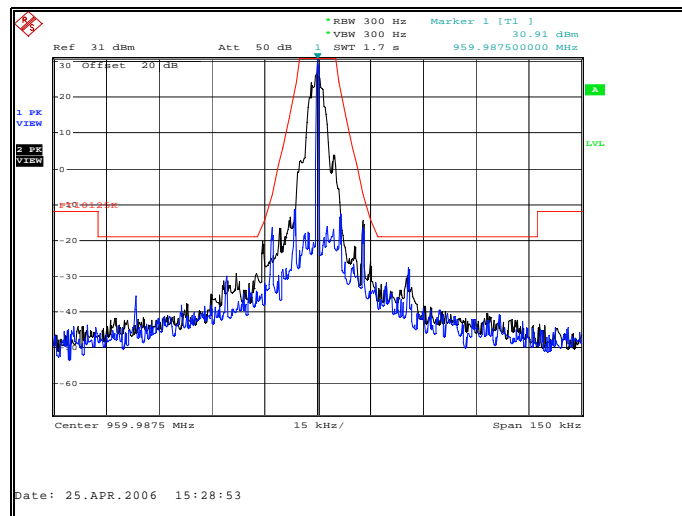

Figure 7.2.4-8: MPass Mode – 959.9875 MHz

7.3 Spurious Emissions at Antenna Terminals - FCC Section 2.1051; 24.133 a(1), a(2); 90.210 (j); 101.111 a (6)

7.3.1 Measurement Procedure

The RF output of the equipment under test was directly connected to the input of the Spectrum Analyzer through a 20 dB passive attenuator. The spectrum analyzer resolution bandwidth was set to 30 kHz below 1000 MHz and 1 MHz above 1000 MHz. The internal correction factors of the spectrum analyzer were employed to correct for any cable or attenuator losses. The spectrum was investigated in accordance to CFR 47 Part 2.1057.

7.3.2 Measurement Results

Data was collected at the low, middle, and high end of the operating range of the device in the mode that produced the worst case emissions. Plots are supplied in Figure 7.3.2-1 through 7.3.2.6.

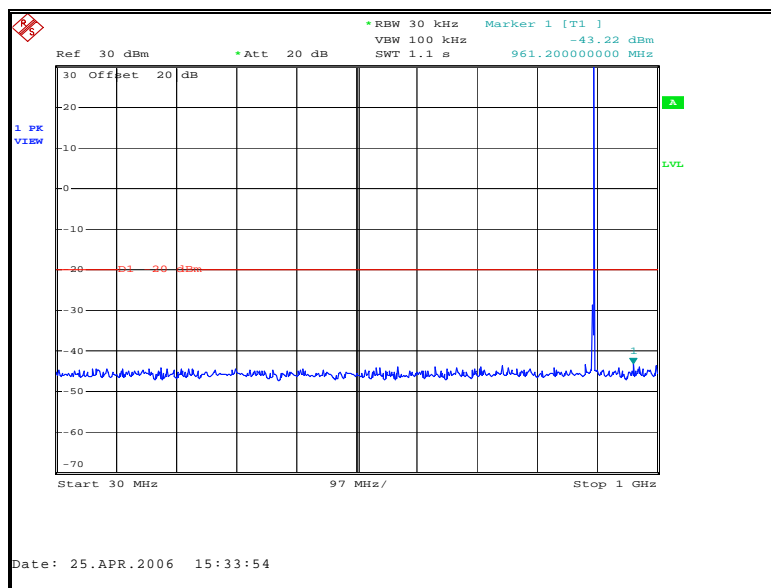

Figure 7.3.2-1: Normal Mode – 896.0375 MHz – 30MHz to 1GHz

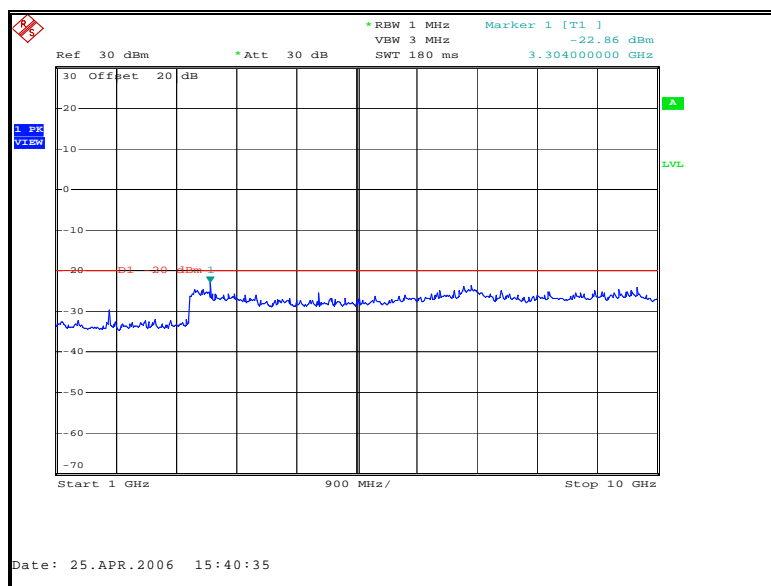

Figure 7.3.2-2: Normal Mode – 896.0375 MHz – 1GHz to 10GHz

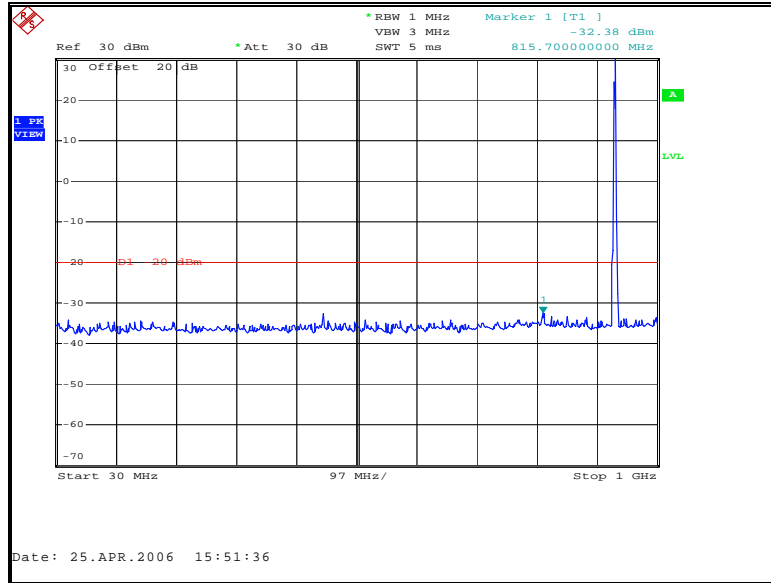

Figure 7.3.2-3: Mpass Mode – 930.1125 MHz – 30MHz to 1GHz

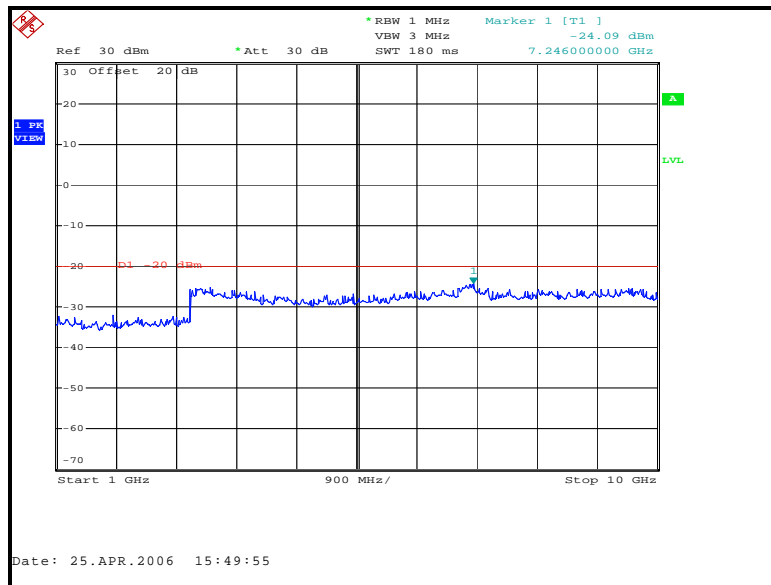

Figure 7.3.2-4: Mpass Mode – 930.1125 MHz – 1GHz to 10GHz

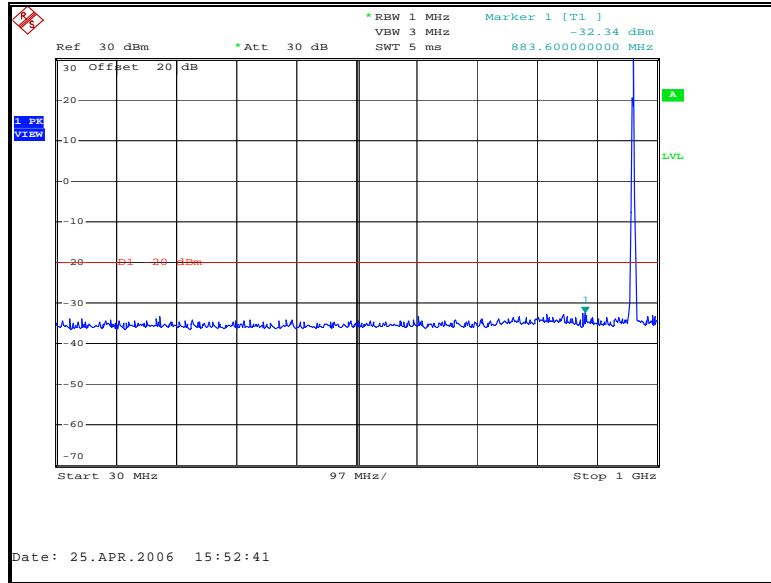

Figure 7.3.2-5: MPass Mode – 959.9875 MHz – 30MHz to 1GHz

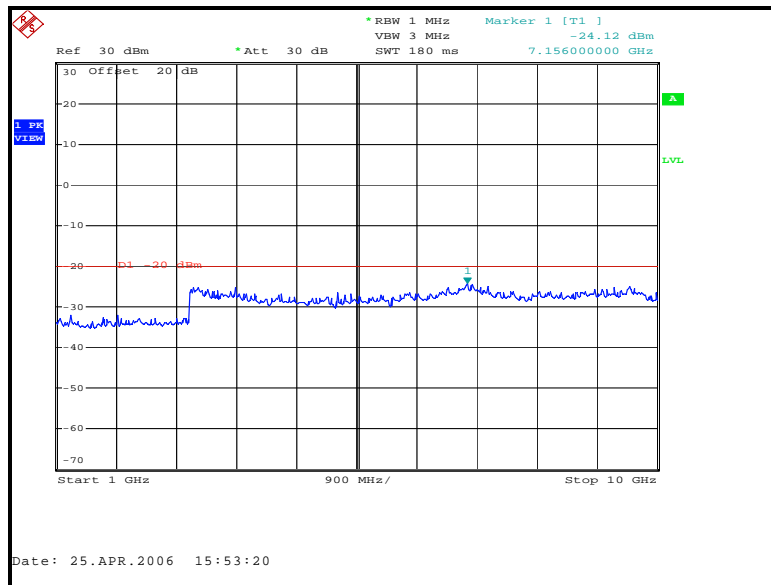

Figure 7.3.2-6: MPass Mode – 959.9875 MHz – 1GHz to 10GHz

7.4 Field Strength of Spurious Emissions - FCC Section 2.1053, 24.133, 90.210, and 101.111

7.4.1 Measurement Procedure

The equipment under test is placed in the Semi-Anechoic Chamber (described in section 2.3.1) on a wooden table at the turntable center. For each spurious emission, the antenna mast is raised and lowered from one (1) to four (4) meters and the turntable is rotated 360° and the maximum reading on the spectrum analyzer is recorded. This was repeated for both horizontal and vertical polarizations of the receive antenna.

The equipment under test is then replaced with a substitution antenna fed by a signal generator. The signal generator's frequency is set to that of the spurious emission recorded from the equipment under test. The antenna mast is raised and lowered from one (1) to four (4) meters to obtain a maximum reading on the spectrum analyzer. The output of the signal generator is then adjusted until the reading on the spectrum analyzer matches that obtained from the equipment under test. The signal generator level is recorded. The power in dBm of each spurious emission is calculated by correcting the signal generator level for the cable loss and gain of the substitution antenna referenced to a dipole. The spectrum was investigated in accordance to CFR 47 Part 2.1057.

Data was collected at the low, middle, and high end of the operating range of the device. Results of the test are shown below in Table 7.4.2-1 and 7.4.2-3. The magnitude of all spurious emissions not reported were attenuated below the noise floor of the measurement system and therefore not specified in this report.

7.4.2 Measurement Results

Table 7.4.2-1: Field Strength of Spurious Emissions – 896 MHz – Normal Mode

Frequency (MHz)	Spectrum Analyzer Level (dBm)	Generator Level (dBm)	Antenna Polarity (H/V)	Correction Factors (dB)	Corrected Level (dBm)	Limit (dBm)	Margin (dB)
1792.125	-57.55	-62.00	H	5.37	-56.63	-20.00	36.63
1792.125	-55.95	-58	V	5.37	-52.63	-20.00	32.63
2688.1875	-60.12	-60	H	5.75	-54.25	-20.00	34.25
2688.1875	-59.84	-59	V	5.75	-53.25	-20.00	33.25
3584.25	-61.49	-61	H	6.01	-54.99	-20.00	34.99
3584.25	-61.28	-60	V	6.01	-53.99	-20.00	33.99
4480.3125	-56.23	-55	H	6.70	-48.30	-20.00	28.30
4480.3125	-58.39	-57	V	6.70	-50.30	-20.00	30.30
5376.375	-59.71	-55	H	5.94	-49.06	-20.00	29.06
5376.375	-59.96	-59	V	5.94	-53.06	-20.00	33.06
6272.4375	-61.67	-55	H	6.05	-48.95	-20.00	28.95
7168.5	-57.53	-46	H	4.95	-41.05	-20.00	21.05
7168.5	-59.91	-52	V	4.95	-47.05	-20.00	27.05
8064.5625	-48.44	-34	H	5.91	-28.09	-20.00	8.09
8064.5625	-51.1	-38	V	5.91	-32.09	-20.00	12.09
8960.625	-57.1	-43	H	5.87	-37.13	-20.00	17.13
8960.625	-58.34	-47	V	5.87	-41.13	-20.00	21.13

Table 7.4.2-2: Field Strength of Spurious Emissions – 930 MHz – MPass Mode

Frequency (MHz)	Spectrum Analyzer Level (dBm)	Generator Level (dBm)	Antenna Polarity (H/V)	Correction Factors (dB)	Corrected Level (dBm)	Limit (dBm)	Margin (dB)
1860.225	-57.60	-59.00	H	5.39	-53.61	-20.00	33.61
1860.225	-56.69	-57	V	5.39	-51.61	-20.00	31.61
2790.3375	-61.01	-61	H	5.81	-55.19	-20.00	35.19
2790.3375	-60.12	-60	V	5.81	-54.19	-20.00	34.19
3720.45	-62.5	-63	H	5.89	-57.11	-20.00	37.11
3720.45	-62.55	-61	V	5.89	-55.11	-20.00	35.11
4650.5625	-53.41	-48	H	6.52	-41.48	-20.00	21.48
4650.5625	-54.61	-49	V	6.52	-42.48	-20.00	22.48
5580.675	-59.36	-52	H	5.94	-46.06	-20.00	26.06
5580.675	-59.25	-52	V	5.94	-46.06	-20.00	26.06
6510.7875	-62.28	-55	H	6.01	-48.99	-20.00	28.99
7440.9	-51.38	-37	H	5.28	-31.72	-20.00	11.72
7440.9	-54.86	-43	V	5.28	-37.72	-20.00	17.72
8371.0125	-49.58	-35	H	5.92	-29.08	-20.00	9.08
8371.0125	-51	-37	V	5.92	-31.08	-20.00	11.08
9301.125	-62.4	-55	H	6.06	-48.94	-20.00	28.94
9301.125	-61.13	-53	V	6.06	-46.94	-20.00	26.94

Table 7.4.2-3: Field Strength of Spurious Emissions – 960MHz – MPass Mode

Frequency (MHz)	Spectrum Analyzer Level (dBm)	Generator Level (dBm)	Antenna Polarity (H/V)	Correction Factors (dB)	Corrected Level (dBm)	Limit (dBm)	Margin (dB)
1919.925	-55.52	-55.00	H	5.41	-49.59	-20.00	29.59
1919.925	-52.8	-50	V	5.41	-44.59	-20.00	24.59
2879.8875	-60.62	-57	H	5.87	-51.13	-20.00	31.13
2879.8875	-60.62	-59	V	5.87	-53.13	-20.00	33.13
3839.85	-62.71	-59	H	5.79	-53.21	-20.00	33.21
3839.85	-61.46	-55	V	5.79	-49.21	-20.00	29.21
4799.8125	-55.44	-48	H	6.31	-41.69	-20.00	21.69
4799.8125	-58.42	-53	V	6.31	-46.69	-20.00	26.69
5759.775	-58.11	-53	H	5.99	-47.01	-20.00	27.01
5759.775	-58.9	-53	V	5.99	-47.01	-20.00	27.01
6719.7375	-56.71	-47	H	5.47	-41.53	-20.00	21.53
6719.7375	-60.75	-53	V	5.47	-47.53	-20.00	27.53
7679.7	-45.26	-31	H	5.55	-25.45	-20.00	5.45
7679.7	-47.85	-36	V	5.55	-30.45	-20.00	10.45
8639.6625	-55.77	-42	H	5.91	-36.09	-20.00	16.09
8639.6625	-56.61	-43	V	5.91	-37.09	-20.00	17.09
9599.625	-62.91	-56	V	6.18	-49.82	-20.00	29.82

7.5 Frequency Stability - FCC Section 2.1055, 24.135, 90.213, 101.107

7.5.1 Measurement Procedure

The equipment under test is placed inside an environmental chamber. The RF output is directly coupled to the input of the measurement equipment and a power supply is attached to the primary supply voltage.

Frequency measurements were made at the extremes of the of temperature range -30° C to +50° C and at intervals of 10° C at normal supply voltage. A period of time sufficient to stabilize all components of the equipment was allowed at each frequency measurement. At a temperature 20° C the supply voltage was varied from 85% to 115% from the normal. The maximum variation of frequency was recorded.

Data was collected at the low and high end of the operating range of the device. Results of the test are shown below in Figure 7.5.2-1 through 7.5.2-2.

7.5.2 Measurement Results

Frequency Stability

Frequency (MHz): 896.0375
 Deviation Limit (PPM): 1.0ppm

Temperature C	Frequency MHz	Frequency Error (PPM)	Voltage (%)	Voltage (VDC)
-30 C	896.037410	-0.100	100%	3.10
-20 C	896.037500	0.000	100%	3.10
-10 C	896.037420	-0.089	100%	3.10
0 C	896.037354	-0.163	100%	3.10
10 C	896.037442	-0.065	100%	3.10
20 C	896.037445	-0.061	100%	3.10
30 C	896.037471	-0.032	100%	3.10
40 C	896.037447	-0.059	100%	3.10
50 C	896.037451	-0.055	100%	3.10
20 C	896.037470	-0.033	85%	2.64
20 C	896.037490	-0.011	115%	3.57

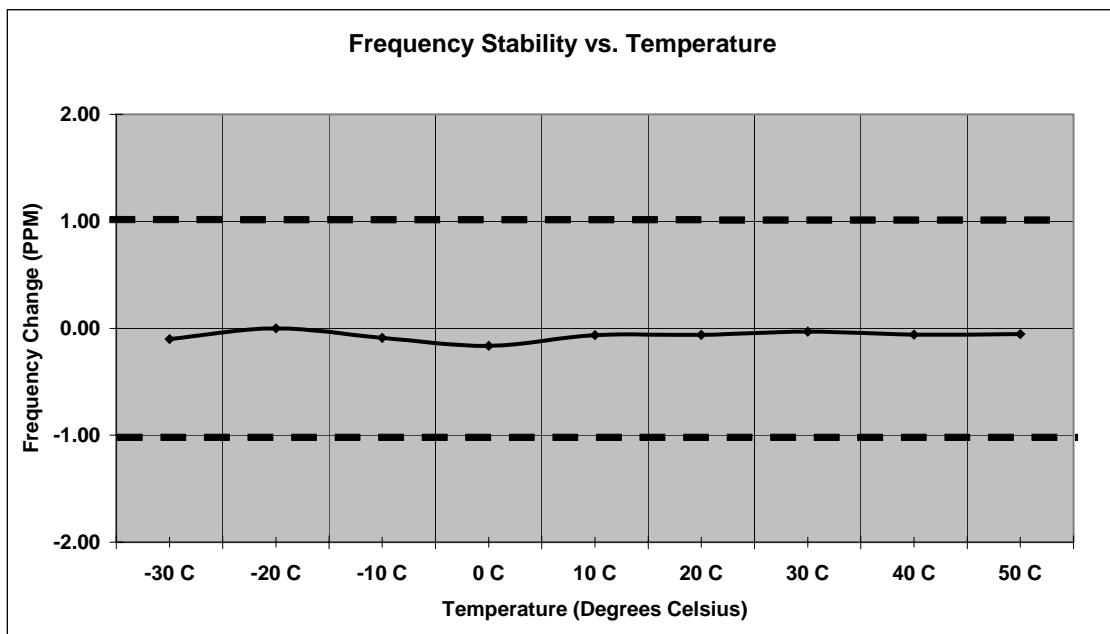

Figure 7.5.2-1: Frequency Stability – 896MHz

Frequency Stability

Frequency (MHz): 959.9875

Deviation Limit (PPM): 1.0ppm

Temperature C	Frequency MHz	Frequency Error (PPM)	Voltage (%)	Voltage (VDC)
-30 C	959.987452	-0.050	100%	3.10
-20 C	959.987487	-0.014	100%	3.10
-10 C	959.987358	-0.148	100%	3.10
0 C	959.987356	-0.150	100%	3.10
10 C	959.987445	-0.057	100%	3.10
20 C	959.987524	0.025	100%	3.10
30 C	959.987496	-0.004	100%	3.10
40 C	959.987461	-0.041	100%	3.10
50 C	959.987466	-0.035	100%	3.10
20 C	959.987510	0.010	85%	2.64
20 C	959.987504	0.004	115%	3.57

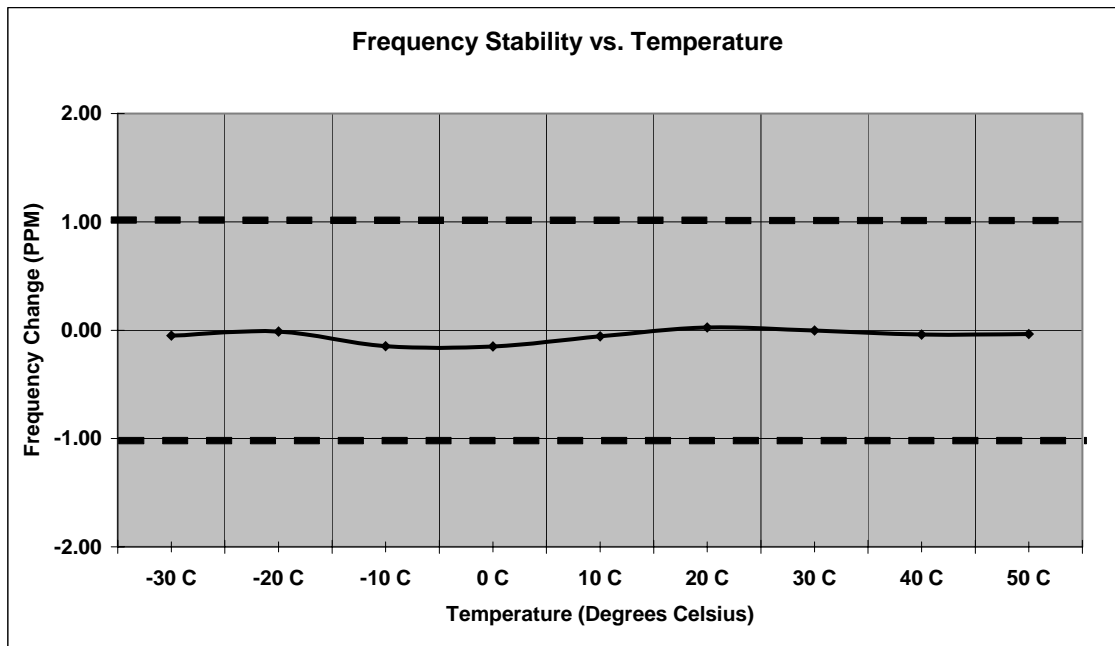

Figure 7.5.2-2: Frequency Stability – 960MHz

7.6 Radiated Emissions (Unintentional Radiators) - FCC Section 15.109

7.6.1 Measurement Procedure

The equipment under test is placed in the Semi-Anechoic Chamber (described in section 2.3.1) on a wooden table at the turntable center. For each radiated emission, the antenna mast is raised and lowered from one (1) to four (4) meters and the turntable is rotated 360° to obtain a maximum peak reading on the spectrum analyzer. The radiated emissions are then measured using an EMI receiver employing a CISPR quasi-peak detector for frequencies below 1000 MHz and an Average detector function for frequencies above 1000 MHz. This repeated for both horizontal and vertical polarizations of the receive antenna.

The field strength of each radiated emission is calculated by correcting the EMI receiver level for cable loss, amplifier gain, and antenna correction factors.

$$\text{Field Strength (dB}\mu\text{V/m)} = \text{EMI Receiver Level (dB}\mu\text{V)} + \text{Cable Loss (dB)} - \text{Amplifier Gain (dB)} + \text{Antenna Correction Factor (1/m)}$$

Results of the test are shown below in Table 7.6.2-1.

7.6.2 Measurement Results

Table 7.6.2-1: Radiated Emissions Tabulated Data

Frequency (MHz)	Height (cm)	Azimuth (deg)	Level (dB μ V/m)	Limit (dB μ V/m)	Margin (dB)
30.00	390	102	12.6	40.0	27.4
45.04	370	339	4.3	40.0	35.7
83.12	330	102	2.1	40.0	37.9
97.12	390	124	13.6	43.5	29.9
131.44	370	272	8.2	43.5	35.3
202.00	100	321	6.5	43.5	37.0
352.40	210	317	12.0	46.0	34.0
483.76	337	124	16.2	46.0	29.8
688.88	318	339	19.6	46.0	26.4
958.72	370	24	24.5	46.0	21.5

7.7 Power Line Conducted Emissions - FCC Section 15.107

7.7.1 Measurement Procedure

The device under test is battery powered therefore power line conducted emission measurements were not required.

8.0 CONCLUSION

In the opinion of ACS, Inc. the model 510 and 520, manufactured by Sensus, meets all the requirements of FCC Part 24, 90, and 101 as applicable.

End Report