

## **Certification Test Report**

**FCC ID: SDB520Q**

**FCC Rule Part: Part 90 Subpart I**

**ACS Report Number: 15-2105.W04.1A**

Applicant: Sensus Metering Systems, Inc.  
Model: 520Q

Test Begin Date: October 19, 2015  
Test End Date: October 22, 2015

Report Issue Date: November 18, 2015



For The Scope of Accreditation Under Certificate Number AT-1533

This report must not be used by the client to claim product certification, approval, or endorsement by ANAB, ANSI, or any agency of the Federal Government.

**Project Manager:**

A handwritten signature in black ink, appearing to read "Thierry Jean-Charles".

**Thierry Jean-Charles  
EMC Engineer  
Advanced Compliance Solutions, Inc.**

This test report shall not be reproduced except in full. This report may be reproduced in part with prior written consent of ACS, Inc. The results contained in this report are representative of the sample(s) submitted for evaluation.

**This report contains 19 pages**

# Table of Content

---

<b>1.0 GENERAL</b> -----	<b>3</b>
1.1 PURPOSE-----	3
1.2 PRODUCT DESCRIPTION-----	3
1.3 TEST METHODOLOGY-----	3
1.4 EMISSION DESIGNATORS -----	4
<b>2.0 TEST FACILITIES</b> -----	<b>5</b>
2.1 LOCATION -----	5
2.2 LABORATORY ACCREDITATIONS/RECOGNITIONS/CERTIFICATIONS -----	5
2.3 RADIATED & CONDUCTED EMISSIONS TEST SITE DESCRIPTION -----	6
<b>3.0 APPLICABLE STANDARD REFERENCES</b> -----	<b>7</b>
<b>4.0 LIST OF TEST EQUIPMENT</b> -----	<b>8</b>
<b>5.0 SUPPORT EQUIPMENT</b> -----	<b>9</b>
<b>6.0 EQUIPMENT UNDER TEST SETUP AND BLOCK DIAGRAM</b> -----	<b>9</b>
<b>7.0 SUMMARY OF TESTS</b> -----	<b>10</b>
7.1 RF POWER OUTPUT -----	10
7.2 OCCUPIED BANDWIDTH (EMISSION LIMITS)-----	12
7.3 SPURIOUS EMISSIONS AT ANTENNA TERMINALS-----	14
7.4 FIELD STRENGTH OF SPURIOUS EMISSIONS-----	16
7.5 FREQUENCY STABILITY-----	17
<b>8.0 CONCLUSION</b> -----	<b>19</b>

## **1.0 GENERAL**

### **1.1 Purpose**

The purpose of this report is to demonstrate compliance with Part 2 Subpart J, and Part 90 Subpart I of the FCC's Code of Federal Regulations for a Class 2 Permissive Change.

The objective of the Class 2 Permissive Change is to add the 464.6625 MHz - 464.7125 MHz band to the filing. There are no hardware or power changes on the product.

### **1.2 Product Description**

The 520Q is a transceiver module that is configured using an RF interface. The unit provides wireless communication capability to a variety of register read, TouchCoupler water meters and TFRs.

The 520Q can be connected to one or two meters simultaneously each of independent type and protocol. The device will communicate via the Sensus fixed wireless telemetry network to provide meter readings and diagnostic data from the meter to the utility provider via radio.

Manufacturer Information:  
Sensus Metering Systems, Inc.  
639 Davis Drive  
Morrisville, NC 27560

Test Sample Serial Numbers: 14003036 (Radiated Emissions), 14003008 (RF Conducted)

Test Sample Condition: The unit was in good operating conditions with no physical damages.

### **1.3 Test Methodology**

#### **1.3.1 Configurations and Justification**

The 520Q was tested in accordance to WT Docket No. 11-56, DA 11-1316 which waives 47 CFR 90.203(j) from the test requirements. The 520Q provides multiple modulations formats/modes all of which were evaluated and the worst case data are presented were applicable.

For the RF conducted measurements, the EUT was modified with a temporary RF connector at the antenna port. Compliance for the frequency behavior is documented during the original certification effort and this test was not repeated during this evaluation.

For radiated emissions, the EUT was evaluated in the orientation of typical installation.

The evaluation for unintentional emissions is documented separately in a verification report.

**1.3.2 In-Band Testing Methodology**

The EUT band of operation is provided in the table below.

CFR Title 47 Rule Part	Frequency Band of Operation (MHz)
90	451.0375 – 454.0
90	456.0 – 462.5375
90	462.7375 – 463.7875
90	464.6625 – 464.7125

The evaluation effort addresses the additional band of 464.6625 MHz – 464.7125 MHz. Based on the requirements set forth in accordance 47 CFR 2.1046-2.1057 as stated above, the methodology in selecting the places to test in the available bands of operation is outlined in the following table.

CFR Title 47 Rule Part	Frequency Band of Operation (MHz)	Location in the Range of Operation	Approx. Test Freq.
90	464.6625 – 464.7125	middle	464.6875

**1.4 Emission Designators**

The 520Q transmitter produces seven distinct modulation formats as documented in the original filing. The 464.6625 MHz – 464.7125 MHz band uses two modulations. The emissions designators for the modulation types used by the 520Q transmitter are as follows:

EMISSIONS DESIGNATORS:

MPass Mode (5 kbps): 5K90F1D

MPass Mode (10 kbps): 11K8F1D

## **2.0 TEST FACILITIES**

### **2.1 Location**

Unless otherwise noted, the radiated and conducted emissions test sites are located at the following addresses.

Advanced Compliance Solutions, Inc.  
3998 FAU Blvd, Suite 310  
Boca Raton, Florida 33431  
Phone: (561) 961-5585  
Fax: (561) 961-5587  
[www.acstestlab.com](http://www.acstestlab.com)

FCC Test Firm Registration Number: 475089

### **2.2 Laboratory Accreditations/Recognitions/Certifications**

ACS, Boca Raton, Florida, is accredited to ISO/IEC 17025 by ANSI-ASQ National Accreditation Board under their ANAB program and has been issued certificate number AT-1533 in recognition of this accreditation.

### 2.3 Radiated & Conducted Emissions Test Site Description

#### 2.3.1 Semi-Anechoic Chamber Test Site

The EMC radiated test facility consists of an RF-shielded enclosure. The interior dimensions of the indoor semi-anechoic chamber are approximately 48 feet (14.6 m) long by 36 feet (10.8 m) wide by 24 feet (7.3 m) high and consist of rigid, 1/8 inch (0.32 cm) steel-clad, wood core modular panels with steel framing. In the shielded enclosure, the faces of the panels are galvanized and the chamber is self-supporting. 8-foot RF absorbing cones are installed on 4 walls and the ceiling. The steel-clad ground plane is covered with vinyl flooring.

The turntable is driven by pneumatic motor, which is capable of supporting a 2000 lb. load. The turntable is flush with the chamber floor which it is connected to, around its circumference, with metallic loaded springs. An EMCO Model 1051 multi-device controller controls the turntable position.

A pneumatic motor is used to control antenna polarizations and height relative to the ground. The height information is displayed on the control unit EMCO Model 1050.

The control room is an RF shielded enclosure attached to the semi-anechoic chamber with two bulkhead panels for connecting RF, and control cables. The dimension of the room is 7.3 m x 4.9 m x 3 m high and the entrance doors of both control and conducted rooms are 3 feet (0.91 m) by 7 feet (2.13 m).

A diagram of the Semi-Anechoic Chamber Test Site is shown in Figure 2.3.1-1 below:

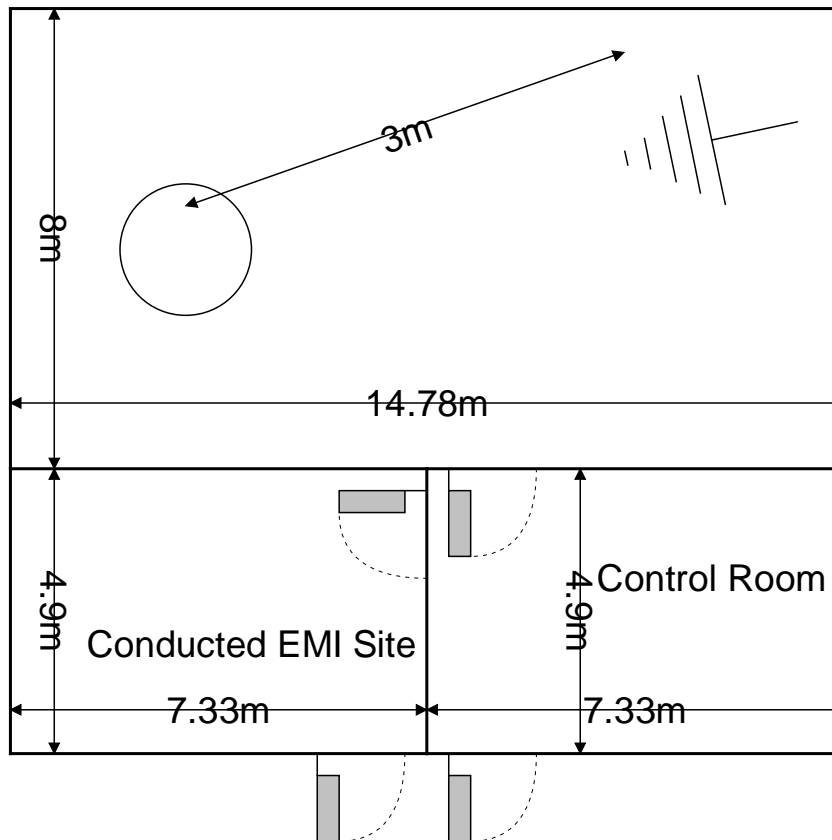

Figure 2.3.1-1: Semi-Anechoic Chamber Test Site

### 2.3.2 Conducted Emissions Test Site Description

The dimensions of the shielded conducted room are 7.3 x 4.9 x 3 m<sup>3</sup>. Power line conducted emission data is taken using two LISNs; a Solar Model 8028-50 50 Ω/50 μH and an EMCO Model 3825, which are installed as shown in Photograph 3. For evaluations requiring 230 V, 50 Hz, a Polarad LISN (S/N 879341/048) is used in conjunction with a 1 kVA, 50 Hz/230 V EDGAR variable frequency generator, Model 1001B.

A diagram of the room is shown below in figure 2.3.2-1:

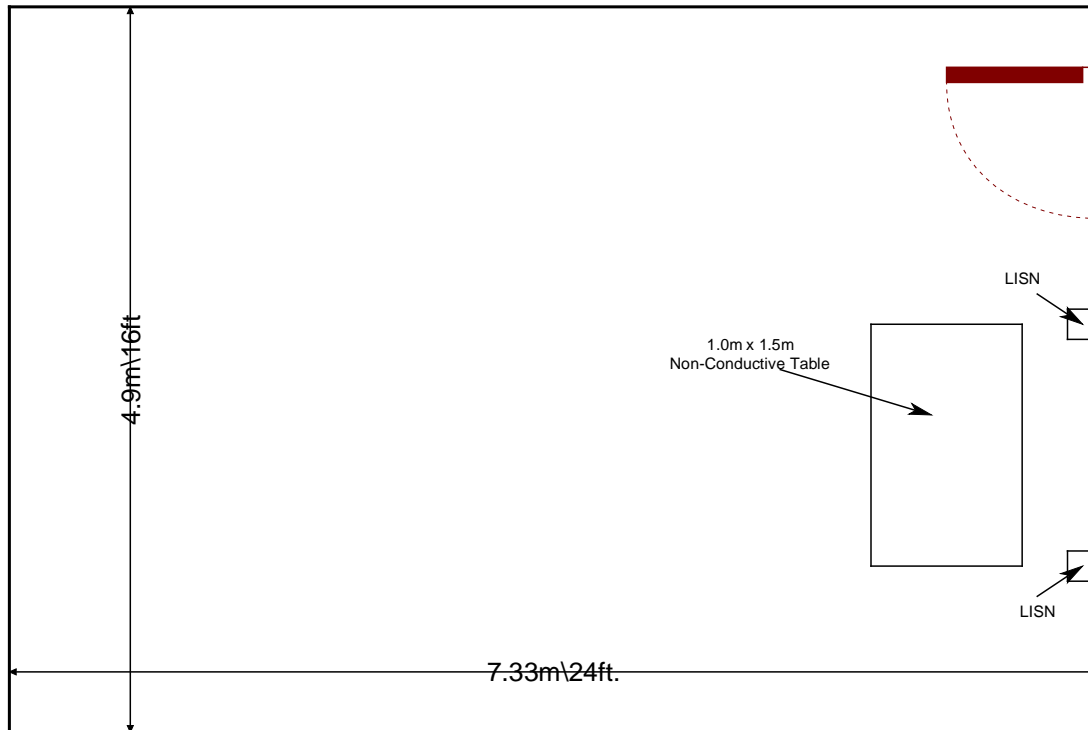

Figure 2.3.2-1: AC Mains Conducted EMI Site

### 3.0 APPLICABLE STANDARD REFERENCES

The following standards were used:

- 1 - US Code of Federal Regulations (CFR): Title 47, Part 2, Subpart J: Equipment Authorization Procedures - 2015
- 2 - US Code of Federal Regulations (CFR): Title 47, Part 90, Subpart I: Private Land Mobile Radio Services – 2015
- 3 – TIA-603-C: Land Mobile FM or PM - Communications Equipment - Measurement and Performance Standards – 2004

#### 4.0 LIST OF TEST EQUIPMENT

The calibration interval of test equipment is annually or the manufacturer's recommendations. Where the calibration interval deviates from the annual cycle based on the instrument manufacturer's recommendations, it shall be stated below.

**Table 4-1: ACS Test Equipment**

AssetID	Manufacturer	Model #	Equipment Type	Serial #	Last Calibration Date	Calibration Due Date
523	Agilent	E7405	Spectrum Analyzers	MY45103293	12/26/2014	12/26/2016
2002	EMCO	3108	Antennas	2147	11/22/2013	11/22/2015
2004	EMCO	3146	Antennas	1385	11/22/2013	11/22/2015
2005	FAU EMI R&D Lab	Lazarus	Antennas	EM001	1/27/2014	1/27/2016
2006	EMCO	3115	Antennas	2573	4/14/2015	4/14/2017
2007	EMCO	3115	Antennas	2419	1/27/2014	1/27/2016
2011	Hewlett-Packard	HP 8447D	Amplifiers	2443A03952	12/31/2014	12/31/2015
2073	Mini Circuits	NHP-800	Filter	10247	12/31/2014	12/31/2015
2075	Hewlett Packard	8495B	Attenuators	2626A11012	1/1/2015	1/1/2016
2089	Agilent Technologies, Inc.	83017A	Amplifiers	3123A00214	12/12/2014	12/12/2015
2094	Mini Circuits	SHP-1000+	Filter	R UU27401137	3/27/2015	3/27/2016
2095	ETS Lindgren	TILE4! - Version 4.2.A	Software	85242	NCR	NCR
2102	Test Equity	115	Environmental Chamber	150892	3/13/2015	3/13/2016
2108	Fluke	115	Digital MultiMeter	99211160	4/2/2015	4/2/2016
2112	Teledyne Storm Products	921-0101-036	Cables	12-06-698	12/31/2014	12/31/2015
2121	ACS Boca	Radiated Cable Set	Cable Set	2121	8/22/2015	8/22/2016
2122	ACS Boca	Radiated Cable Set	Cable Set	2122	8/29/2015	8/29/2016
RE563	Hewlett Packard	8673D	Signal Generators	3034A01078	4/2/2015	4/2/2016
RE597	BK Precision	1692	Power Supplies	S940035931	NCR	NCR
RE619	Rhode & Schwarz	ESU	Spectrum Analyzers	1302.6005K26 Ser. 100190	11/5/2014	11/5/2016

**NCR=No Calibration Required**



5.0 SUPPORT EQUIPMENT

Table 5-1: Support Equipment

Item #	Type Device	Manufacturer	Model/Part #	Serial #
1	EUT	Sensus Metering Systems, Inc.	520Q	14003036
2	DC Power Supply	BK Precision	1692	S940035931

Table 5-2: Cable Description

Cable #	Cable Type	Length	Shield	Termination
A	2 Wire Conductor	1.75 m	No	EUT to Power Supply
B	Power Cord	1.8m	No	Power Supply to AC Mains

6.0 EQUIPMENT UNDER TEST SETUP AND BLOCK DIAGRAM

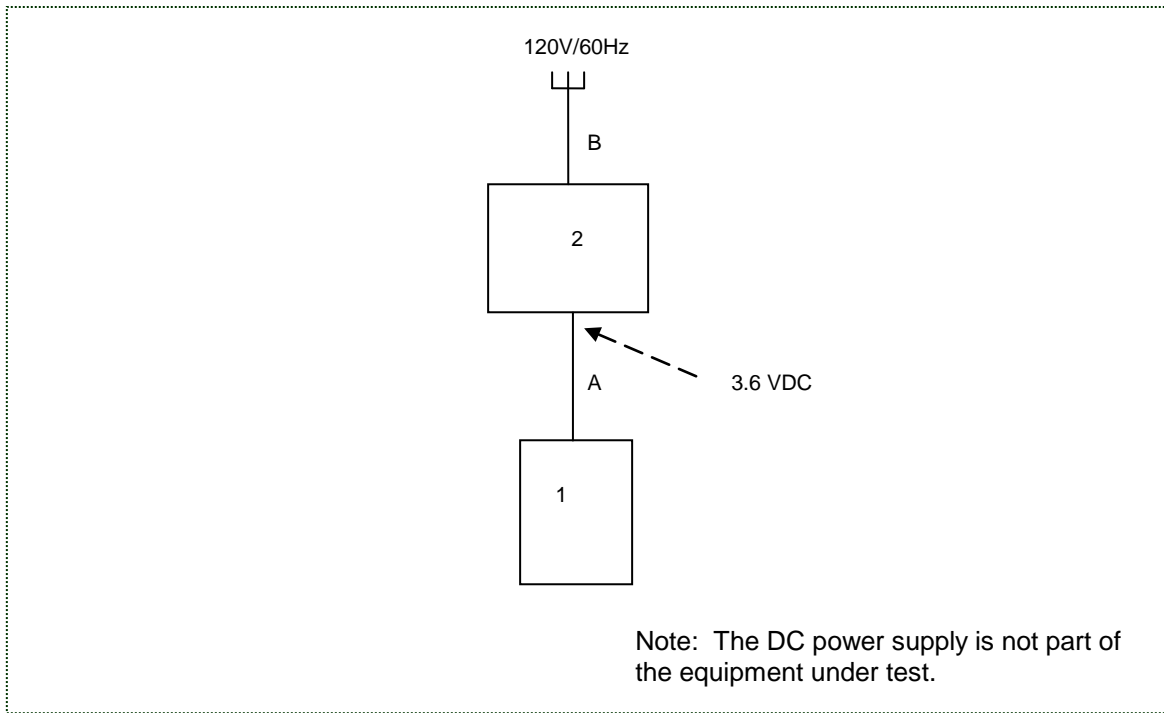

Figure 6-1: EUT Test Setup

**7.0 SUMMARY OF TESTS**

Along with the tabular data shown below, plots were taken of all signals deemed important enough to document.

**Table 7-1: Test Results Summary**

Test Parameter	Test Summary
RF Power Output	Pass
Occupied Bandwidth (Emissions Limits)	Pass
Spurious Emissions at Antenna Terminals	Pass
Field Strength of Spurious Emissions	Pass
Frequency Stability	Pass

**7.1 RF Power Output**

**7.1.1 Measurement Procedure**

The RF output of the equipment under test was directly connected to the input of the Spectrum Analyzer through 30 dB of passive attenuation. The resolution and video bandwidths of the spectrum analyzer were set at sufficient levels, >> signal bandwidth, to produce accurate results. The internal correction factors of the spectrum analyzer were employed to correct for any cable or attenuator losses. Results are shown below.

**7.1.2 Measurement Results**

**Part 90.205**

**Table 7.1.2-1: Peak Output Power**

Frequency (MHz)	FCC Rule Part	Output Power (dBm)
464.6875	90	28.61

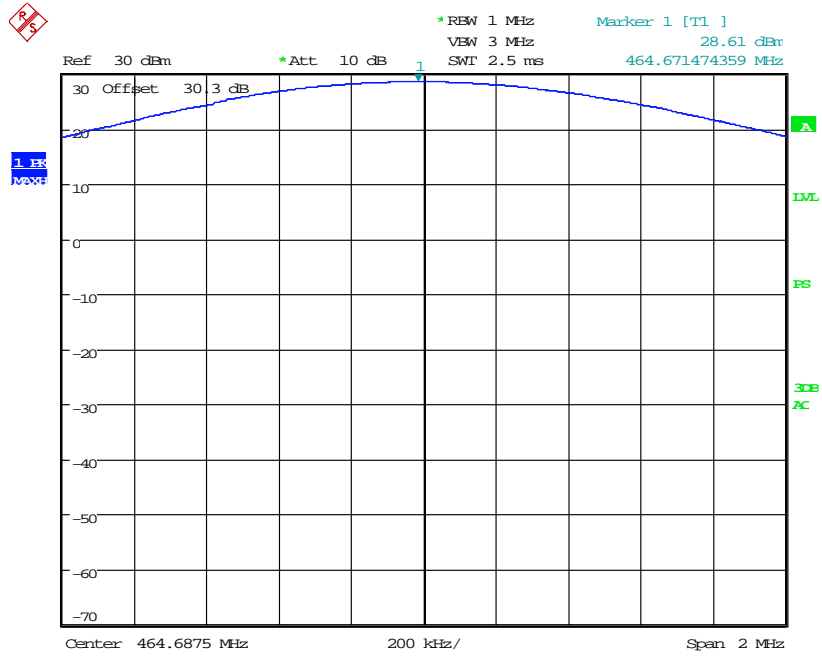

Date: 22.OCT.2015 19:58:05

Figure 7.1.2-1: Peak Output Power – 464.6875 MHz

## 7.2 Occupied Bandwidth (Emission Limits)

### 7.2.1 Measurement Procedure

The RF output of the equipment under test was directly connected to the input of the Spectrum Analyzer through 30 dB of passive attenuation. The spectrum analyzer resolution and video bandwidths were set to 300 Hz and 3000 Hz respectively. The internal correction factors of the spectrum analyzer were employed to correct for any cable or attenuator losses. Results of the test are shown below for all modes of operation.

### 7.2.2 Measurement Results

#### Part 90.210(c)

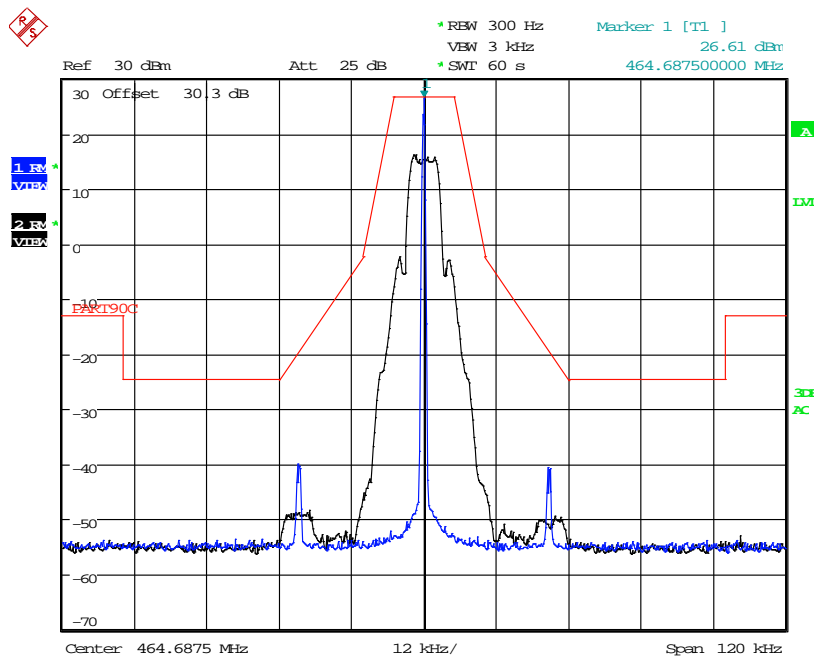

Date: 22.OCT.2015 19:09:44

Figure 7.2.2-1: 464.6875 MHz – MPass 5k Mode

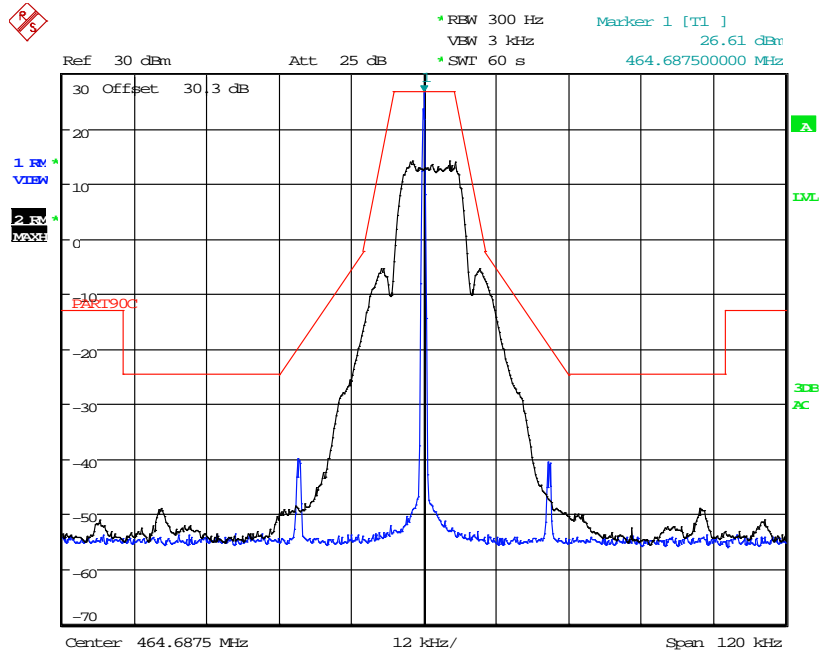

Date: 22.OCT.2015 19:46:42

Figure 7.2.2-2: 464.6875 MHz – MPass 10k Mode

### 7.3 Spurious Emissions at Antenna Terminals

#### 7.3.1 Measurement Procedure

The RF output of the equipment under test was directly connected to the input of the Spectrum Analyzer through 30 dB of passive attenuation. The spectrum analyzer resolution bandwidth was set to 100 kHz below 1000 MHz and 1 MHz above 1000 MHz. The internal correction factors of the spectrum analyzer were employed to correct for any cable, attenuator or filter losses. The spectrum was investigated in accordance to CFR 47 Part 2.1057. Results are shown below.

#### 7.3.2 Measurement Results

##### Part 90.210(c)

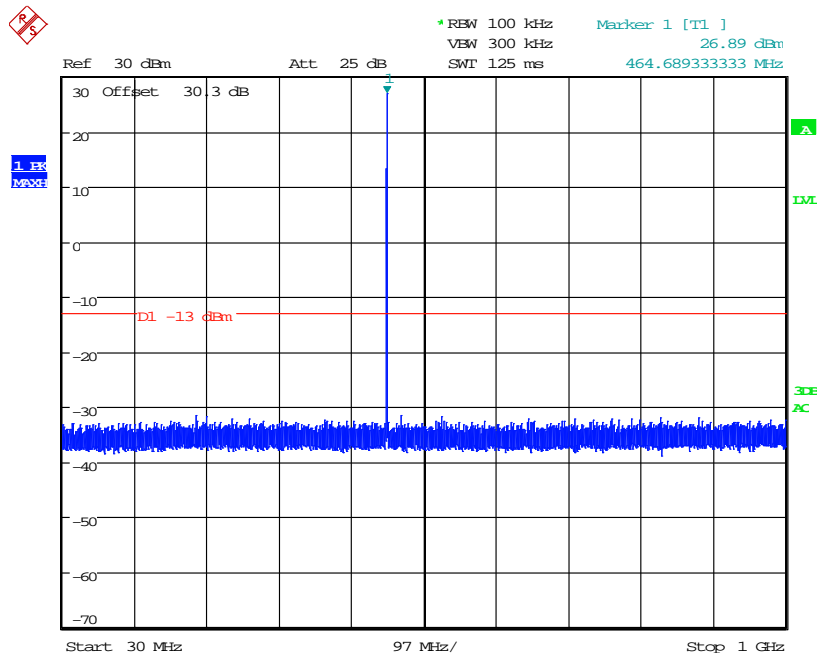

Date: 22.OCT.2015 20:16:12

Figure 7.3.2-1: 464.6875 MHz – 30MHz to 1GHz

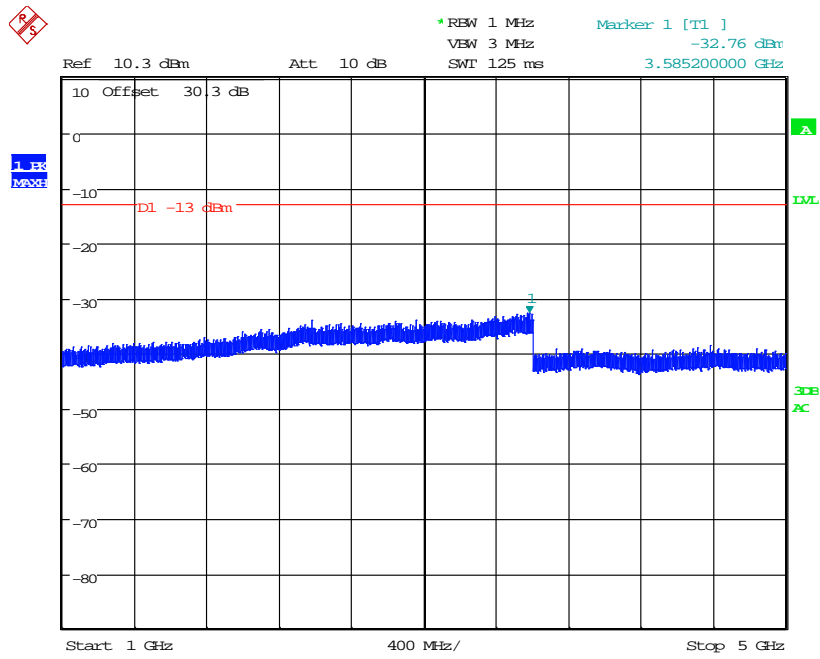

Date: 22.OCT.2015 20:14:22

Figure 7.3.2-2: 464.6875 MHz – 1GHz to 5GHz

## 7.4 Field Strength of Spurious Emissions

### 7.4.1 Measurement Procedure

The equipment under test is placed in the Semi-Anechoic Chamber (described in section 2.3.1) on a wooden table at the turntable center. For each spurious emission, the antenna mast is raised and lowered from one (1) to four (4) meters and the turntable is rotated 360° and the maximum reading on the spectrum analyzer is recorded. This was repeated for both horizontal and vertical polarizations of the receive antenna.

The equipment under test is then replaced with a substitution antenna fed by a signal generator. The signal generator's frequency is set to that of the spurious emission recorded from the equipment under test. The antenna mast is raised and lowered from one (1) to four (4) meters to obtain a maximum reading on the spectrum analyzer. The output of the signal generator is then adjusted until the reading on the spectrum analyzer matches that obtained from the equipment under test. The signal generator level is recorded. The power in dBm of each spurious emission is calculated by correcting the signal generator level for the cable loss and gain of the substitution antenna referenced to a dipole. The spectrum was investigated in accordance to CFR 47 Part 2.1057.

The magnitude of all spurious emissions not reported were attenuated below the noise floor of the measurement system and therefore not specified in this report. Results are shown below.

### 7.4.2 Measurement Results

#### Part 90.210(c)

**Table 7.4.2-1: Field Strength of Spurious Emissions – 464.6875 MHz**

Frequency (MHz)	Spectrum Analyzer Level (dBm)	Antenna Polarity (H/V)	Spurious ERP (dBm)	Limit (dBm)	Margin (dB)
929.375	-57.29	H	-51.39	-13.00	38.39
1394.0625	-33.05	H	-37.15	-13.00	24.15
1858.75	-50.77	H	-53.16	-13.00	40.16
2323.4375	-57.88	H	-65.02	-13.00	52.02
2788.125	-59.17	H	-66.55	-13.00	53.55
3252.8125	-61.05	H	-68.63	-13.00	55.63
3717.5	-61.33	H	-68.79	-13.00	55.79
4182.1875	-63.28	H	-72.08	-13.00	59.08
929.375	-57.83	V	-51.94	-13.00	38.94
1394.0625	-34.02	V	-37.53	-13.00	24.53
1858.75	-51.18	V	-54.36	-13.00	41.36
2323.4375	-56.76	V	-62.45	-13.00	49.45
2788.125	-59.28	V	-66.07	-13.00	53.07
3252.8125	-61.34	V	-68.12	-13.00	55.12
3717.5	-61.75	V	-68.84	-13.00	55.84
4182.1875	-63.23	V	-71.94	-13.00	58.94

NOTE: All frequencies not listed were below the noise floor of the spectrum analyzer.



## **7.5 Frequency Stability**

### **7.5.1 Measurement Procedure**

The equipment under test is placed inside an environmental chamber. The RF output is directly coupled to the input of the measurement equipment and a power supply is attached to the primary supply voltage.

Frequency measurements were made at the extremes of the of temperature range  $-30^{\circ}\text{C}$  to  $+50^{\circ}\text{C}$  and at intervals of  $10^{\circ}\text{C}$  at normal supply voltage. A period of time sufficient to stabilize all components of the equipment was allowed at each frequency measurement. At a temperature  $20^{\circ}\text{C}$  the measurements were performed at 85% and 115% of the EUT nominal voltage. The maximum variation of frequency was recorded.

7.5.2 Measurement Results

Part 90.213

# Frequency Stability

Frequency (MHz): 464.6875

Deviation Limit (PPM):

Temperature C	Frequency MHz	Frequency Error (PPM)	Voltage (%)	Voltage (VDC)
-30 C	464.687370	-0.280	100%	3.60
-20 C	464.687570	0.151	100%	3.60
-10 C	464.687562	0.134	100%	3.60
0 C	464.687498	-0.004	100%	3.60
10 C	464.687466	-0.073	100%	3.60
20 C	464.687506	0.013	100%	3.60
30 C	464.687546	0.099	100%	3.60
40 C	464.687538	0.082	100%	3.60
50 C	464.687514	0.030	100%	3.60
20 C	464.687538	0.082	85%	3.06
20 C	464.687538	0.082	115%	4.14

Frequency Stability vs. Temperature

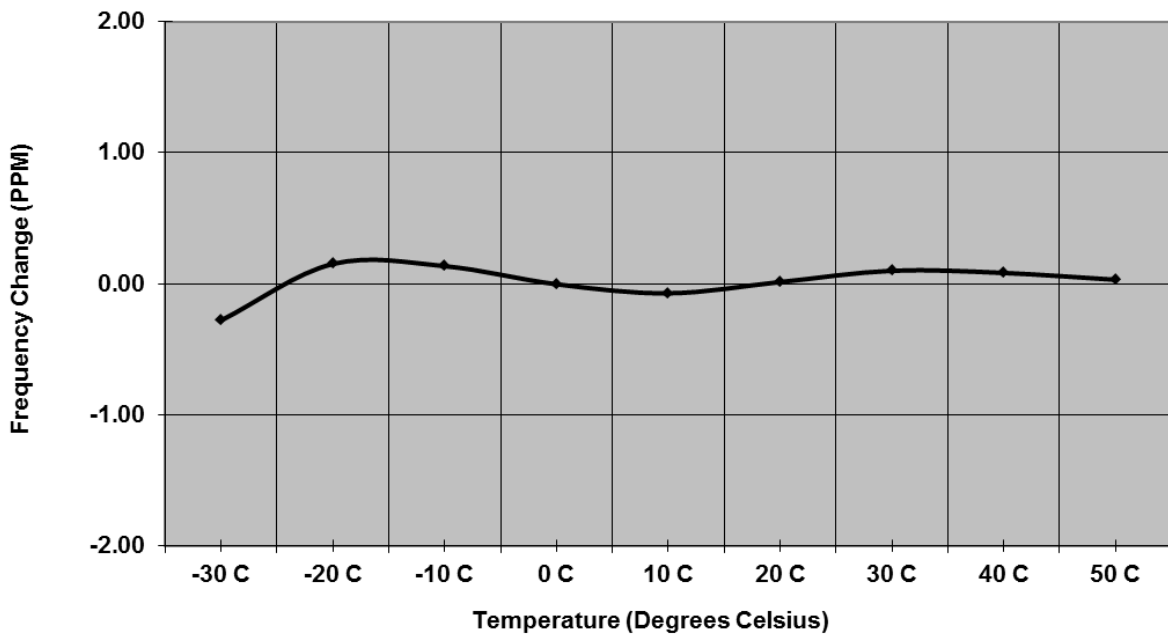

Figure 7.5.2-1: Frequency Stability – 464.6875 MHz

**8.0 CONCLUSION**

In the opinion of ACS, Inc. the model 520Q, manufactured by Sensus Metering Systems, Inc., meets the requirements of FCC Part 90 Subpart I for the tests documented in this test report, as applicable.

End Report