



FCC 47 CFR PART 15 SUBPART C

TEST REPORT

For

AP Router

Model / Trade Name:

WCB1215H5ADX / LanReardy

DAP-3410 / D-Link

TEW-754APB, TEW-758APBO, TEW-759APBO / Trendnet

AMS-P50, AMS-D50, AMS-D50-N / ALCON

CAP-5015DP, CAP-5015D, CAP-5015DX / WiBorne

WLO-35815NP, WLO-35815N, WLO-35800N / Pheenet

PS-200N-X, OW-215N2-X, OW-200N2-X / Cerio

AOP9000 / Phoebe Micro

AC-GTT-11N5-D, AC-GTT-11N5-O / Grand-Tek

Issued to

LanReady Technologies Inc

3F,No.166,Sinhu 2nd .,Neihu District, Taipei City 114 Taiwan(R.O.C.)

Issued by

Compliance Certification Services Inc.

**No.11, Wugong 6th Rd., Wugu Dist.,
New Taipei City 24891, Taiwan. (R.O.C.)**

<http://www.ccsrf.com>

service@ccsrf.com

Issued Date: December 4, 2013



Note: This report shall not be reproduced except in full, without the written approval of Compliance Certification Services Inc. This document may be altered or revised by Compliance Certification Services Inc. personnel only, and shall be noted in the revision section of the document.



Revision History

Rev.	Issue Date	Revisions	Effect Page	Revised By
00	December 4, 2013	Initial Issue	ALL	Eunice Shen



TABLE OF CONTENTS

1. TEST RESULT CERTIFICATION.....	4
2. EUT DESCRIPTION	5
3. TEST METHODOLOGY	7
3.1 EUT CONFIGURATION	7
3.2 EUT EXERCISE.....	7
3.3 GENERAL TEST PROCEDURES.....	7
3.4 FCC PART 15.205 RESTRICTED BANDS OF OPERATIONS.....	8
3.5 DESCRIPTION OF TEST MODES	9
4. INSTRUMENT CALIBRATION.....	10
4.1 MEASURING INSTRUMENT CALIBRATION	10
4.2 MEASUREMENT EQUIPMENT USED	10
4.3 MEASUREMENT UNCERTAINTY	11
5. FACILITIES AND ACCREDITATIONS	12
5.1 FACILITIES	12
5.2 EQUIPMENT.....	12
5.3 TABLE OF ACCREDITATIONS AND LISTINGS.....	13
6. SETUP OF EQUIPMENT UNDER TEST	14
6.1 SETUP CONFIGURATION OF EUT.....	14
6.2 SUPPORT EQUIPMENT	14
7. FCC PART 15.247 REQUIREMENTS.....	15
7.1 6DB BANDWIDTH	15
7.2 PEAK POWER.....	30
7.3 PEAK POWER SPECTRAL DENSITY	32
7.4 SPURIOUS EMISSIONS.....	47
7.5 POWERLINE CONDUCTED EMISSIONS.....	83
APPENDIX I PHOTOGRAPHS OF TEST SETUP.....	86
APPENDIX 1 - PHOTOGRAPHS OF EUT	



1. TEST RESULT CERTIFICATION

Applicant: LanReady Technologies Inc
 3F, No.166, Sinhu 2nd., Neihu District,
 Taipei City 114 Taiwan (R.O.C.)

Equipment Under Test: AP Router

Model Number / Trade Name: WCB1215H5ADX / LanReardy
 DAP-3410 / D-Link
 TEW-754APB, TEW-758APBO, TEW-759APBO / Trendnet
 AMS-P50, AMS-D50, AMS-D50-N / ALCON
 CAP-5015DP, CAP-5015D, CAP-5015DX / WiBorne
 WLO-35815NP, WLO-35815N, WLO-35800N / Pheenet
 PS-200N-X, OW-215N2-X, OW-200N2-X / Cerio
 AOP9000 / Phoebe Micro
 AC-GTT-11N5-D, AC-GTT-11N5-O / Grand-Tek

Date of Test: October 3 ~ December 11, 2013

APPLICABLE STANDARDS	
STANDARD	TEST RESULT
FCC 47 CFR Part 15 Subpart C	No non-compliance noted

We hereby certify that:

The above equipment was tested by Compliance Certification Services Inc. The test data, data evaluation, test procedures, and equipment configurations shown in this report were made in accordance with the procedures given in ANSI C63.4: 2009 and the energy emitted by the sample EUT tested as described in this report is in compliance with the requirements of FCC Rules Part 15.207, 15.209, 15.247.

The test results of this report relate only to the tested sample EUT identified in this report.

Approved by:

Reviewed by:

Miller Lee
 Section Manager
 Compliance Certification Services Inc.

Angel Cheng
 Section Manager
 Compliance Certification Services Inc.



2. EUT DESCRIPTION

Product	AP Router		
Model Number / Trade Name	WCB1215H5ADX / LanReardy DAP-3410 / D-Link TEW-754APB, TEW-758APBO, TEW-759APBO / Trendnet AMS-P50, AMS-D50, AMS-D50-N / ALCON CAP-5015DP, CAP-5015D, CAP-5015DX / WiBorne WLO-35815NP, WLO-35815N, WLO-35800N / Pheenet PS-200N-X, OW-215N2-X, OW-200N2-X / Cerio AOP9000 / Phoebe Micro AC-GTT-11N5-D, AC-GTT-11N5-O / Grand-Tek		
Model Difference	<i>Model</i>	<i>Trade Name</i>	<i>Model Difference</i>
	WCB1215H5ADX	LanReardy	plastic case Internal Antenna (Built In15dbi Patch)
	DAP-3410	D-Link	plastic case Internal Antenna (Built In15dbi Patch)
	TEW-754APB	Trendnet	plastic case Internal Antenna (Built In15dbi Patch)
	AMS-P50	ALCON	plastic case Internal Antenna (Built In15dbi Patch)
	CAP-5015DP	WiBorne	plastic case Internal Antenna (Built In15dbi Patch)
	WLO-35815NP	Pheenet	plastic case Internal Antenna (Built In15dbi Patch)
	PS-200N-X	Cerio	plastic case Internal Antenna (Built In15dbi Patch)
	AOP9000	Phoebe Micro	plastic case Internal Antenna (Built In15dbi Patch)
	OW-215N2-X	Cerio	Aluminum case Internal Antenna (Built In15dbi Patch)
	AMS-D50	ALCON	Aluminum case Internal Antenna (Built In15dbi Patch)
	CAP-5015D	WiBorne	Aluminum case Internal Antenna (Built In15dbi Patch)
	WLO-35815N	Pheenet	Aluminum case Internal Antenna (Built In15dbi Patch)
	OW-200N2-X	Cerio	Aluminum case external Antenna (5 dbi)
	CAP-5015DX	WiBorne	Aluminum case external Antenna (5 dbi)
	WLO-35800N	Pheenet	Aluminum case external Antenna (5 dbi)
	AMS-D50-N	ALCON	Aluminum case external Antenna (5 dbi)
	AC-GTT-11N5-D	Grand-Tek	GTT Iron-hull Internal Antenna (Built In GTT 15dbi Patch)
	TEW-758APBO	TRENDnet	GTT Iron-hull Internal Antenna (Built In GTT 15dbi Patch)
	AC-GTT-11N5-O	Grand-Tek	GTT Iron-hull external Antenna (6dbi)
TEW-759APBO	TRENDnet	GTT Iron-hull external Antenna (6 dbi)	
Received Date	September 24, 2013		



Power Adapter	VDC from Power Adapter 1. Brand: LEI / Model: MU24-B480050-A1 I/P: 100-240V, 0.3A, 50-60Hz, 1.0A O/P: 48V / 0.5A 2. Brand: UNIFIUE / Model: UEC345-4808 I/P: 100-240V, 0.3A, 50-60Hz, 1.0A O/P: 48V / 0.875A
Frequency Range	IEEE 802.11a / IEEE 802.11n HT 20 MHz: 5.745~5.825 GHz IEEE 802.11n HT 40 MHz: 5.755 ~ 5.795 GHz
Transmit Power	IEEE 802.11a mode: 20.98 dBm IEEE 802.11n HT 20 mode: 18.02 dBm IEEE 802.11n HT 40 mode: 18.25 dBm
Modulation Technique & Transmit Data Rate	IEEE 802.11a: OFDM (54, 48, 36, 24, 18, 12, 9, 6 Mbps) IEEE 802.11n HT 20 mode: OFDM (6.5, 7.2, 13, 14.4, 14.44, 19.5, 21.7, 26, 28.89, 28.9, 39, 43.3, 43.33 52, 57.78, 57.8, 58.5, 65.0, 72.2, 78, 86.67, 104, 115.56, 117, 130, 144.44 Mbps) IEEE 802.11n HT 40 mode: OFDM (13.5, 15, 27, 30, 40.5, 45, 54, 60, 81, 90, 108, 120, 121.5, 135, 150, 162, 180, 216, 240, 243, 270, 300 Mbps)
Number of Channels	IEEE 802.11a mode: 5 Channels IEEE 802.11n HT 20 mode: 5 Channels IEEE 802.11n HT 40 mode: 2 Channels
Antenna Specification	1. Omni-directional Antenna / Gain: 5.0dBi 2. Omni-directional Antenna / Gain: 6.0dBi 3. Patch Antenna / Gain: 14.53dBi MIMO: Total ANT=14.53 + 10*LOG(2) = 17.54

Remark:

1. The sample selected for test was production product and was provided by manufacturer.
2. This submittal(s) (test report) is intended for FCC ID: SCDOW161000001 filing to comply with Section 15.207, 15.209 and 15.247 of the FCC Part 15, Subpart C Rules.



3. TEST METHODOLOGY

The tests documented in this report were performed in accordance with ANSI C63.4: 2009 and FCC CFR 47 Part 15.207, 15.209, 15.247, KDB558074.

3.1 EUT CONFIGURATION

The EUT configuration for testing is installed on RF field strength measurement to meet the Commissions requirement and operating in a manner that intends to maximize its emission characteristics in a continuous normal application.

3.2 EUT EXERCISE

The EUT was operated in the engineering mode to fix the TX frequency that was for the purpose of the measurements.

According to its specifications, the EUT must comply with the requirements of the Section 15.207, 15.209 and 15.247 under the FCC Rules Part 15 Subpart C.

3.3 GENERAL TEST PROCEDURES

Conducted Emissions

The EUT is placed on the turntable, which is 0.8 m above ground plane. According to the requirements in Section 13.1.4.1 of ANSI C63.4 Conducted emissions from the EUT measured in the frequency range between 0.15 MHz and 30MHz using CISPR Quasi-peak and average detector modes.

Radiated Emissions

The EUT is placed on a turn table, which is 0.8 m above ground plane. The turntable shall rotate 360 degrees to determine the position of maximum emission level. EUT is set 3m away from the receiving antenna, which varied from 1m to 4m to find out the highest emission. And also, each emission was to be maximized by changing the polarization of receiving antenna both horizontal and vertical. In order to find out the maximum emissions, exploratory radiated emission measurements were made according to the requirements in Section 13.1.4.1 of ANSI C63.4.



3.4 FCC PART 15.205 RESTRICTED BANDS OF OPERATIONS

(a) Except as shown in paragraph (d) of this section, only spurious emissions are permitted in any of the frequency bands listed below:

MHz	MHz	MHz	GHz
0.090 - 0.110	16.42 - 16.423	399.9 - 410	4.5 - 5.15
¹ 0.495 - 0.505	16.69475 - 16.69525	608 - 614	5.35 - 5.46
2.1735 - 2.1905	16.80425 - 16.80475	960 - 1240	7.25 - 7.75
4.125 - 4.128	25.5 - 25.67	1300 - 1427	8.025 - 8.5
4.17725 - 4.17775	37.5 - 38.25	1435 - 1626.5	9.0 - 9.2
4.20725 - 4.20775	73 - 74.6	1645.5 - 1646.5	9.3 - 9.5
6.215 - 6.218	74.8 - 75.2	1660 - 1710	10.6 - 12.7
6.26775 - 6.26825	108 - 121.94	1718.8 - 1722.2	13.25 - 13.4
6.31175 - 6.31225	123 - 138	2200 - 2300	14.47 - 14.5
8.291 - 8.294	149.9 - 150.05	2310 - 2390	15.35 - 16.2
8.362 - 8.366	156.52475 - 156.52525	2483.5 - 2500	17.7 - 21.4
8.37625 - 8.38675	156.7 - 156.9	2655 - 2900	22.01 - 23.12
8.41425 - 8.41475	162.0125 - 167.17	3260 - 3267	23.6 - 24.0
12.29 - 12.293	167.72 - 173.2	3332 - 3339	31.2 - 31.8
12.51975 - 12.52025	240 - 285	3345.8 - 3358	36.43 - 36.5
12.57675 - 12.57725	322 - 335.4	3600 - 4400	(²)
13.36 - 13.41			

¹ Until February 1, 1999, this restricted band shall be 0.490-0.510 MHz.

² Above 38.6

(b) Except as provided in paragraphs (d) and (e), the field strength of emissions appearing within these frequency bands shall not exceed the limits shown in Section 15.209. At frequencies equal to or less than 1000 MHz, compliance with the limits in Section 15.209 shall be demonstrated using measurement instrumentation employing a CISPR quasi-peak detector. Above 1000 MHz, compliance with the emission limits in Section 15.209 shall be demonstrated based on the average value of the measured emissions. The provisions in Section 15.35 apply to these measurements.



3.5 DESCRIPTION OF TEST MODES

The EUT comes with two types of power adapter (MU24-B480050-A1 / UEC345-4808) for sale. After the preliminary test, the power adapter MU24-B480050-A1 was found to emit the worst emissions and therefore had been tested under operating condition.

The powerline conducted emissions test worst emission was found on is model: DAP-3410, conducted emission & radiated emission test worst emission was found on is model: OW-200N2-X, OW-215N2-X

After the preliminary test, the EUT with PoE was found to emit the worst emissions and therefore had been tested under standby condition.

The EUT is a 2x2 configuration spatial MIMO (2Tx & 2Rx) without beam forming function. The 2x2 configuration is implemented with two outside TX & RX chains (Chain 0 and Chain1).

Software used to control the EUT for staying in continuous transmitting mode was programmed. The worst case data rate is determined as the data rate with highest output power.

The field strength of spurious emission was measured in the following position: EUT stand-up position (Z mode), lie-down position (X, Y mode). The worst emission was found in X mode for powerline conducted emissions, Y mode for radiation emissions and the worst cases were recorded.

After verification, all tests were carried out with the worst case test modes as shown below except radiated spurious emission below 1GHz and power line conducted emissions below 30MHz, which worst case was in normal link mode only.

IEEE 802.11a mode:

Channel Low (5745MHz), Channel Mid (5785MHz) and Channel High (5825MHz) with 6Mbps data rate were chosen for full testing.

IEEE 802.11n HT 20 mode:

Channel Low(5745MHz), Channel Mid(5785MHz) and Channel High(5825MHz) with 6.5Mbps data rate were chosen for full testing.

IEEE 802.11n HT 40 mode:

Channel Low(5755MHz) and Channel High(5795MHz) with 13.5Mbps data rate were chosen for full testing.



4. INSTRUMENT CALIBRATION

4.1 MEASURING INSTRUMENT CALIBRATION

The measuring equipment, which was utilized in performing the tests documented herein, has been calibrated in accordance with the manufacturer's recommendations for utilizing calibration equipment, which is traceable to recognized national standards.

4.2 MEASUREMENT EQUIPMENT USED

Equipment Used for Emissions Measurement

Remark: Each piece of equipment is scheduled for calibration once a year.

Conducted Emissions Test Site				
Name of Equipment	Manufacturer	Model	Serial Number	Calibration Due
Spectrum Analyzer	Agilent	E4446A	MY43360131	03/20/2014
Power Meter	Anritsu	ML2495A	1012009	06/04/2014
Power Sensor	Anritsu	MA2411A	0917072	06/04/2014

3M Chamber Test Site				
Name of Equipment	Manufacturer	Model	Serial Number	Calibration Due
Spectrum Analyzer	Agilent	E4446A	US42510268	11/05/2014
EMI Test Receiver	R&S	ESCI	100064	02/28/2014
Pre-Amplifier	Mini-Circuits	ZFL-1000LN	SF350700823	01/12/2014
Pre-Amplifier	MITEQ	AFS44-00102650-42-10P-44	1415367	11/18/2014
Bilog Antenna	Sunol Sciences	JB3	A030105	10/01/2014
Horn Antenna	EMCO	3117	00055165	02/13/2014
Horn Antenna	EMCO	3116	2487	10/09/2014
Loop Antenna	EMCO	6502	8905/2356	06/12/2014
Turn Table	CCS	CC-T-1F	N/A	N.C.R
Antenna Tower	CCS	CC-A-1F	N/A	N.C.R
Controller	CCS	CC-C-1F	N/A	N.C.R
Site NSA	CCS	N/A	N/A	12/22/2013
Test S/W	EZ-EMC (CCS-3A1RE)			

Conducted Emission room				
Name of Equipment	Manufacturer	Model	Serial Number	Calibration Due
EMI Test Receiver	R&S	ESCI	101073	07/30/2014
LISN	R&S	ENV216	101054	06/05/2014
LISN	EMCO	3825/2	9106-1809	07/02/2014
Capacitive Voltage Probe	FCC	F-CVP-1	100185	03/24/2014
Current Probe	FCC	F-65	256	N.C.R.
Test S/W	CCS-3A1-CE			



4.3 MEASUREMENT UNCERTAINTY

PARAMETER	UNCERTAINTY
Powerline Conducted Emission	+/- 1.2575
3M Semi Anechoic Chamber / <200M	+/- 4.0138
3M Semi Anechoic Chamber / 200M~1000M	+/- 3.9483
3M Semi Anechoic Chamber / 1G~8G	+/- 2.5975
3M Semi Anechoic Chamber / 8G~18G	+/- 2.6112
3M Semi Anechoic Chamber / 18G~26G	+/- 2.7389
3M Semi Anechoic Chamber / 26G~40G	+/- 2.9683

Remark: This uncertainty represents an expanded uncertainty expressed at approximately the 95% confidence level using a coverage factor of $k=2$.



5. FACILITIES AND ACCREDITATIONS

5.1 FACILITIES

All measurement facilities used to collect the measurement data are located at

No.199, Chungshen Road, Hsintien City, Taipei Hsien, Taiwan, R.O.C.

Tel: 886-2-2217-0894 / Fax: 886-2-2217-1029

No.11, Wugong 6th Rd., Wugu Dist., New Taipei City 24891, Taiwan. (R.O.C.)

Tel: 886-2-2299-9720 / Fax: 886-2-2298-4045

No.81-1, Lane 210, Bade 2nd Rd., Lujhu Township, Taoyuan County 33841, TAIWAN, R.O.C.

Tel: 886-3-324-0332 / Fax: 886-3-324-5235

The sites are constructed in conformance with the requirements of ANSI C63.7, ANSI C63.4 and CISPR Publication 22.

5.2 EQUIPMENT

Radiated emissions are measured with one or more of the following types of linearly polarized antennas: tuned dipole, biconical, log periodic, bi-log, and/or ridged waveguide, horn. Spectrum analyzers with pre-selectors and quasi-peak detectors are used to perform radiated measurements.



Conducted emissions are measured with Line Impedance Stabilization Networks and EMI Test Receivers.

Calibrated wideband preamplifiers, coaxial cables, and coaxial attenuators are also used for making measurements.

All receiving equipment conforms to CISPR Publication 16-1, "Radio Interference Measuring Apparatus and Measurement Methods."



5.3 TABLE OF ACCREDITATIONS AND LISTINGS

Country	Agency	Scope of Accreditation	Logo
USA	FCC	3M Semi Anechoic Chamber (FCC MRA: TW1039) to perform FCC Part 15 measurements	 FCC MRA: TW1039
Taiwan	TAF	LP0002, RTTE01, FCC Method-47 CFR Part 15 Subpart C, D, E, RSS-210, RSS-310 IDA TS SRD, AS/NZS 4268, AS/NZS 4771, TS 12.1 & 12.2, ETSI EN 300 440-1, ETSI EN 300 440-2, ETSI EN 300 328, ETSI EN 300 220-1, ETSI EN 300 220-2, ETSI EN 301 893, ETSI EN 301 489-1/3/7/17 FCC OET Bulletin 65 + Supplement C, EN 50360, EN 50361, EN 50371, RSS 102, EN 50383, EN 50385, EN 50392, IEC 62209, CNS 14958-1, CNS 14959 FCC Method -47 CFR Part 15 Subpart B IEC / EN 61000-3-2, IEC / EN 61000-3-3, IEC / EN 61000-4-2/3/4/5/6/8/11	 Testing Laboratory 1309
Canada	Industry Canada	3M Semi Anechoic Chamber (IC 2324G-1 / IC 2324G-2) to perform	 IC 2324G-1 IC 2324G-2

* No part of this report may be used to claim or imply product endorsement by A2LA or any agency of the US Government.



6. SETUP OF EQUIPMENT UNDER TEST

6.1 SETUP CONFIGURATION OF EUT

See test photographs attached in Appendix 1 for the actual connections between EUT and support equipment.

6.2 SUPPORT EQUIPMENT

No.	Device Type	Brand	Model	Series No.	FCC ID	Data Cable	Power Cord
1.	Notebook PC	DELL	PP19L	61G6Q1S	FCC DoC	N/A	AC I/P: Unshielded, 1.8m DC O/P: Unshielded, 1.8m with a core

Remark:

1. All the equipment/cables were placed in the worst-case configuration to maximize the emission during the test.
2. Grounding was established in accordance with the manufacturer's requirements and conditions for the intended use.



7. FCC PART 15.247 REQUIREMENTS

7.1 6dB BANDWIDTH

LIMIT

According to §15.247(a)(2), systems using digital modulation techniques may operate in the 902 - 928 MHz, 2400 - 2483.5 MHz, and 5725 - 5850 MHz bands. The minimum 6dB bandwidth shall be at least 500 kHz.

Test Configuration

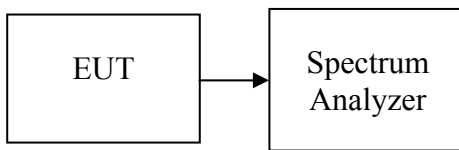

TEST PROCEDURE

The transmitter output is connected to the spectrum analyzer. Set the RBW=100KHz the emission bandwidth, VBW $\geq 3 \times$ RBW, Detector = Peak, Trace mode = max hold, Sweep = auto couple. Measure the maximum width of the emission that is constrained by the frequencies associated with the two amplitude points (upper and lower) that are attenuated by 6dB relative to the maximum level measured in the fundamental emission.

TEST RESULTS

No non-compliance noted



Test Data

Test mode: IEEE 802.11a mode

Channel	Frequency (MHz)	6dB Bandwidth (MHz)	Limit (kHz)	Result
Low	5745	16.5	>500	PASS
Mid	5785	16.5833		PASS
High	5825	16.5833		PASS

Test mode: IEEE 802.11n HT 20 mode / Chain 0

Channel	Frequency (MHz)	6dB Bandwidth (MHz)	Limit (kHz)	Result
Low	5745	17.8334	>500	PASS
Mid	5785	17.8333		PASS
High	5825	17.75		PASS

Test mode: IEEE 802.11n HT 20 mode / Chain 1

Channel	Frequency (MHz)	6dB Bandwidth (MHz)	Limit (kHz)	Result
Low	5745	17.8333	>500	PASS
Mid	5785	17.8333		PASS
High	5825	17.8333		PASS

Test mode: IEEE 802.11n HT 40 mode / Chain 0

Channel	Frequency (MHz)	6dB Bandwidth (MHz)	Limit (kHz)	Result
Low	5755	36.3	>500	PASS
High	5795	36.4		PASS

Test mode: IEEE 802.11n HT 40 mode / Chain 1

Channel	Frequency (MHz)	6dB Bandwidth (MHz)	Limit (kHz)	Result
Low	5755	36.4	>500	PASS
High	5795	36.4		PASS



Test Plot

IEEE 802.11a mode

6dB Bandwidth (CH Low)

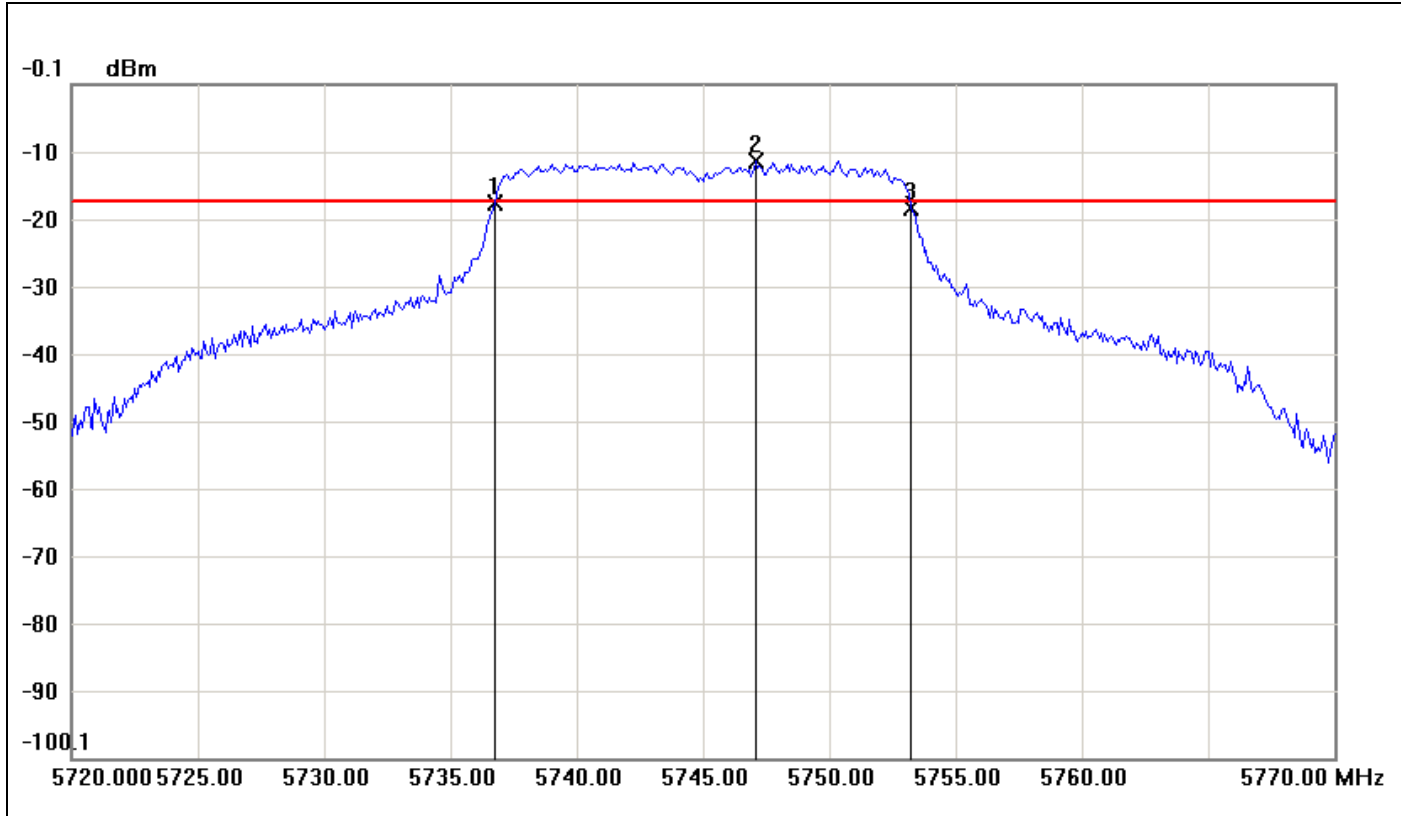

No.	Frequency(MHz)	Result(dBm)	Limit(dBm)	Margin(dBm)
1	5736.7500	-17.77	-17.33	-0.44
2	5747.0833	-11.33	-17.33	6.00
3	5753.2500	-18.32	-17.33	-0.99

No.		Δ Frequency(MHz)	Δ Level(dB)
1	mk3-mk1	16.5	-0.55



6dB Bandwidth (CH Mid)

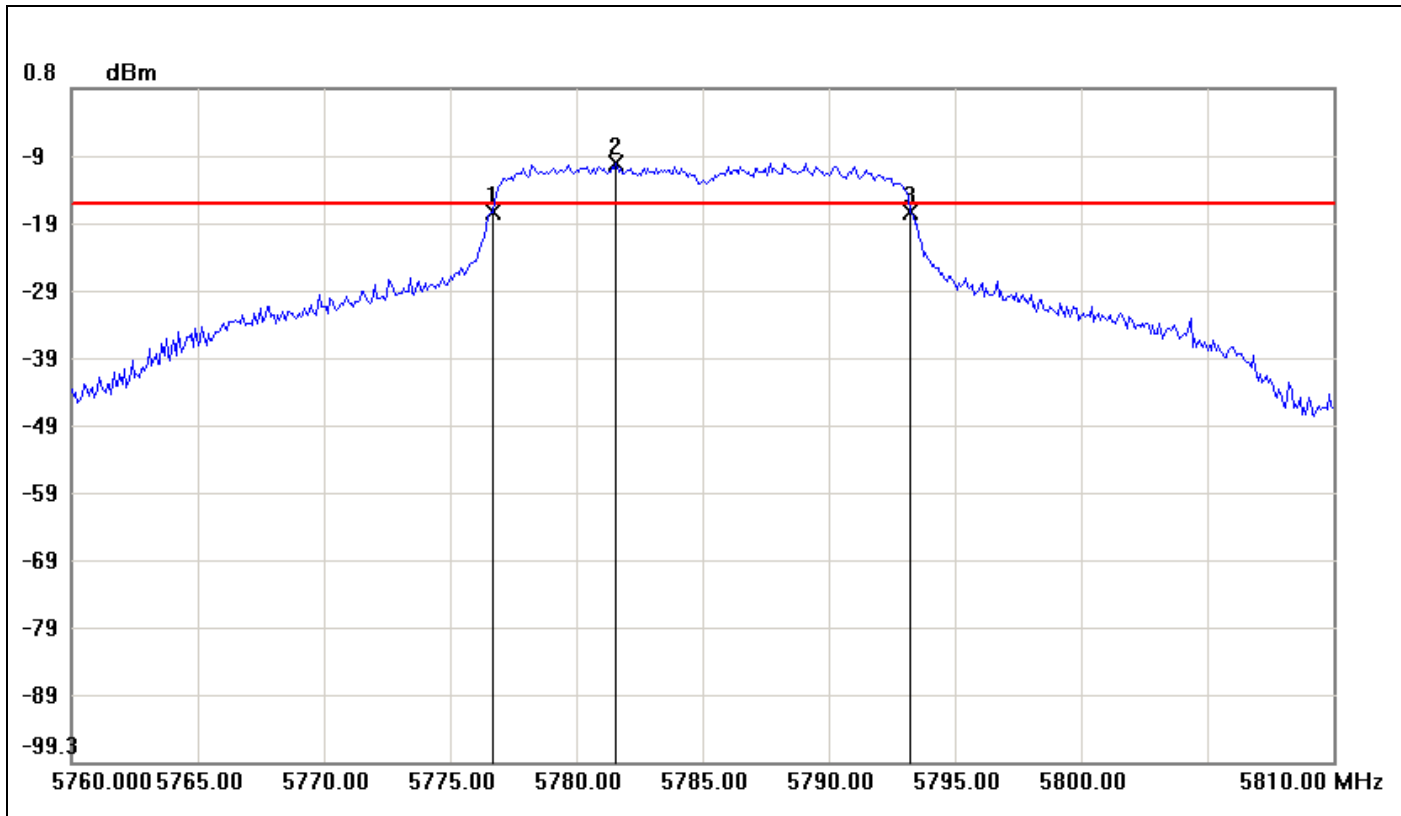

No.	Frequency(MHz)	Result(dBm)	Limit(dBm)	Margin(dBm)
1	5776.6667	-17.55	-16.32	-1.23
2	5781.5833	-10.32	-16.32	6.00
3	5793.2500	-17.64	-16.32	-1.32

No.		Δ Frequency(MHz)	Δ Level(dB)
1	mk3-mk1	16.5833	-0.09



6dB Bandwidth (CH High)

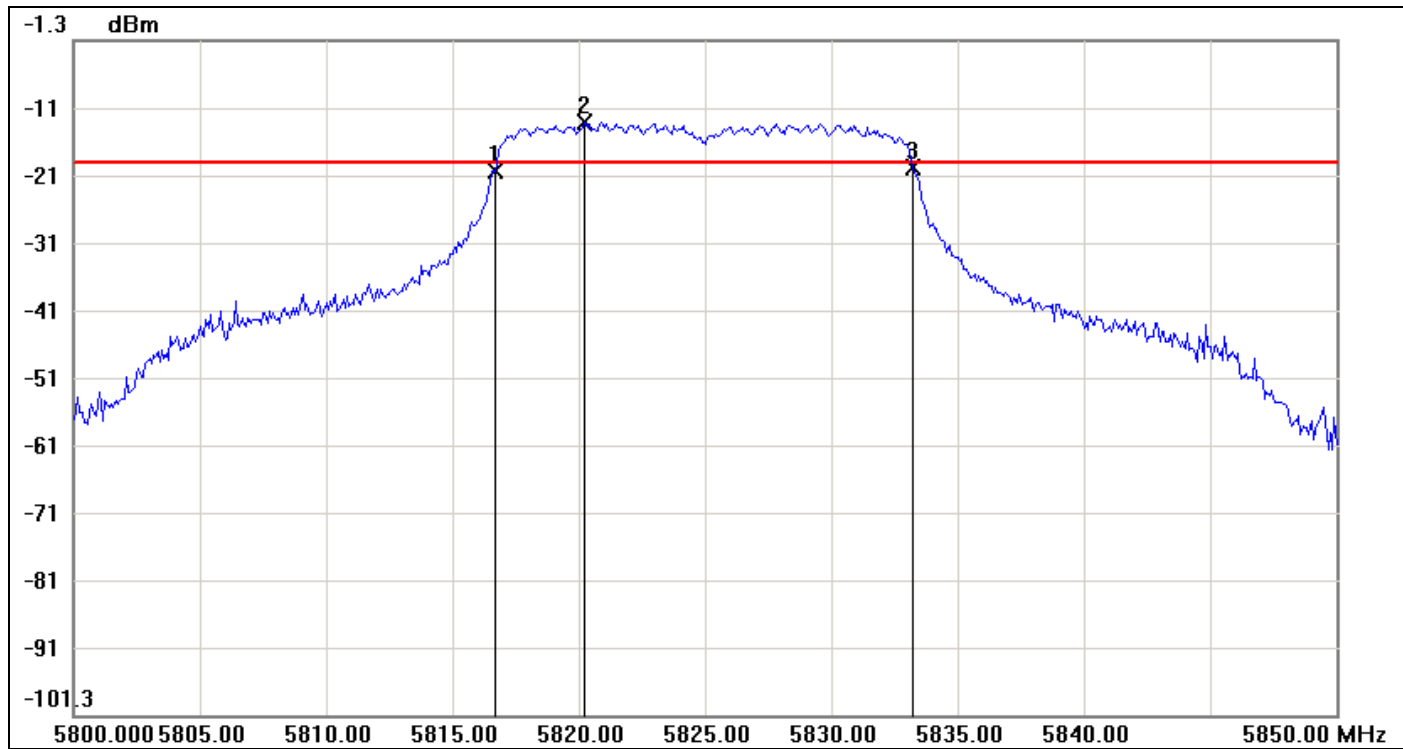

No.	Frequency(MHz)	Result(dBm)	Limit(dBm)	Margin(dBm)
1	5816.6667	-20.58	-19.42	-1.16
2	5820.2500	-13.42	-19.42	6.00
3	5833.2500	-20.08	-19.42	-0.66

No.		Δ Frequency(MHz)	Δ Level(dB)
1	mk3-mk1	16.5833	0.5



IEEE 802.11n HT 20 mode / Chain 0

6dB Bandwidth (CH Low)

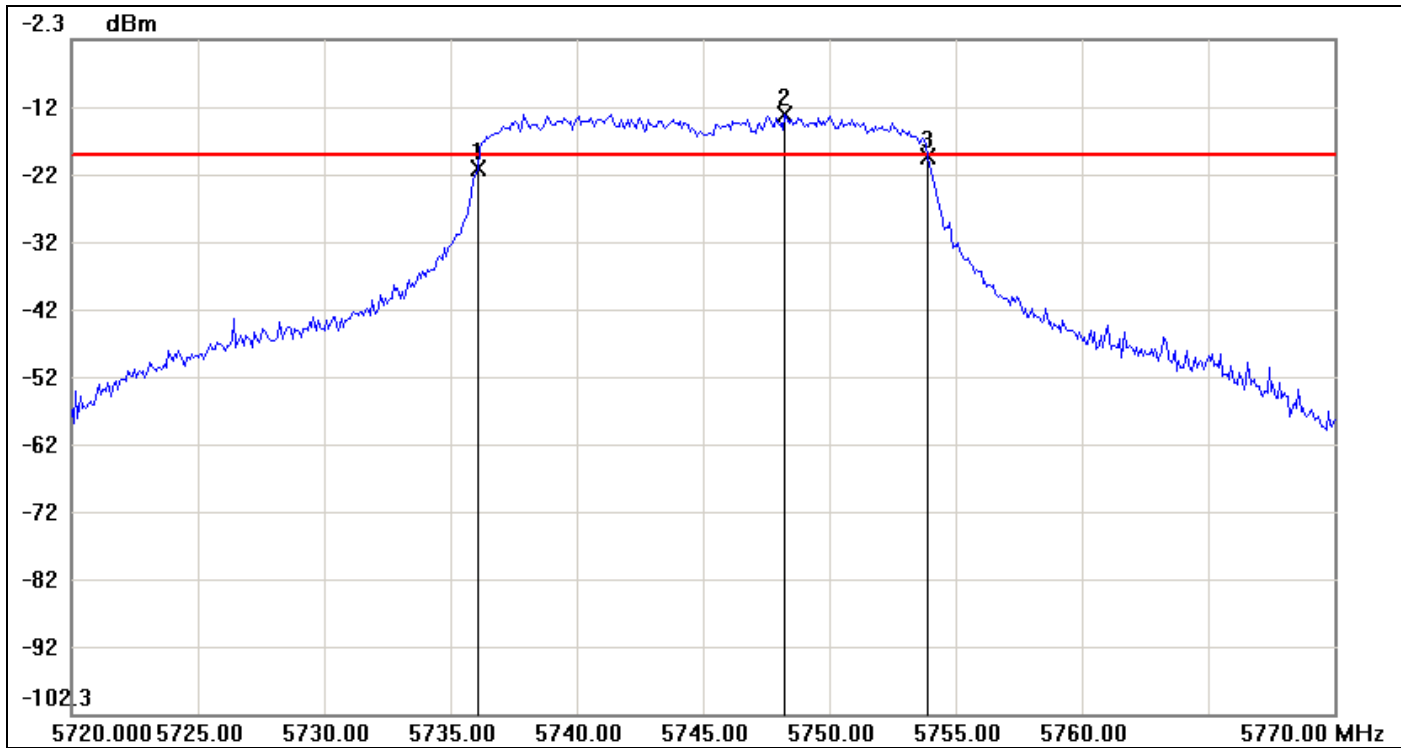

No.	Frequency(MHz)	Result(dBm)	Limit(dBm)	Margin(dBm)
1	5736.0833	-21.53	-19.47	-2.06
2	5748.2500	-13.47	-19.47	6.00
3	5753.9167	-19.55	-19.47	-0.08

No.		Δ Frequency(MHz)	Δ Level(dB)
1	mk3-mk1	17.8334	1.98



6dB Bandwidth (CH Mid)

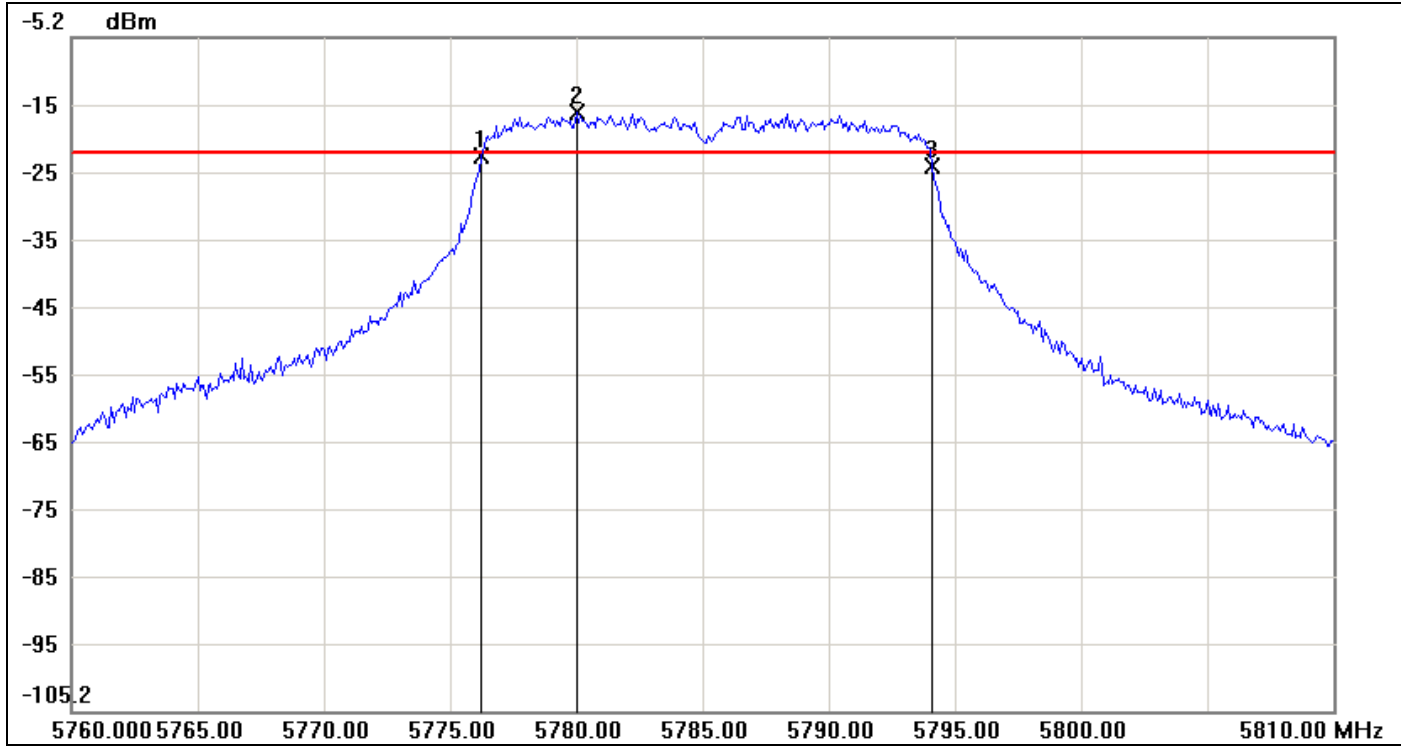

No.	Frequency(MHz)	Result(dBm)	Limit(dBm)	Margin(dBm)
1	5776.2500	-22.89	-22.25	-0.64
2	5780.0000	-16.25	-22.25	6.00
3	5794.0833	-24.35	-22.25	-2.10

No.		Δ Frequency(MHz)	Δ Level(dB)
1	mk3-mk1	17.8333	-1.46



6dB Bandwidth (CH High)

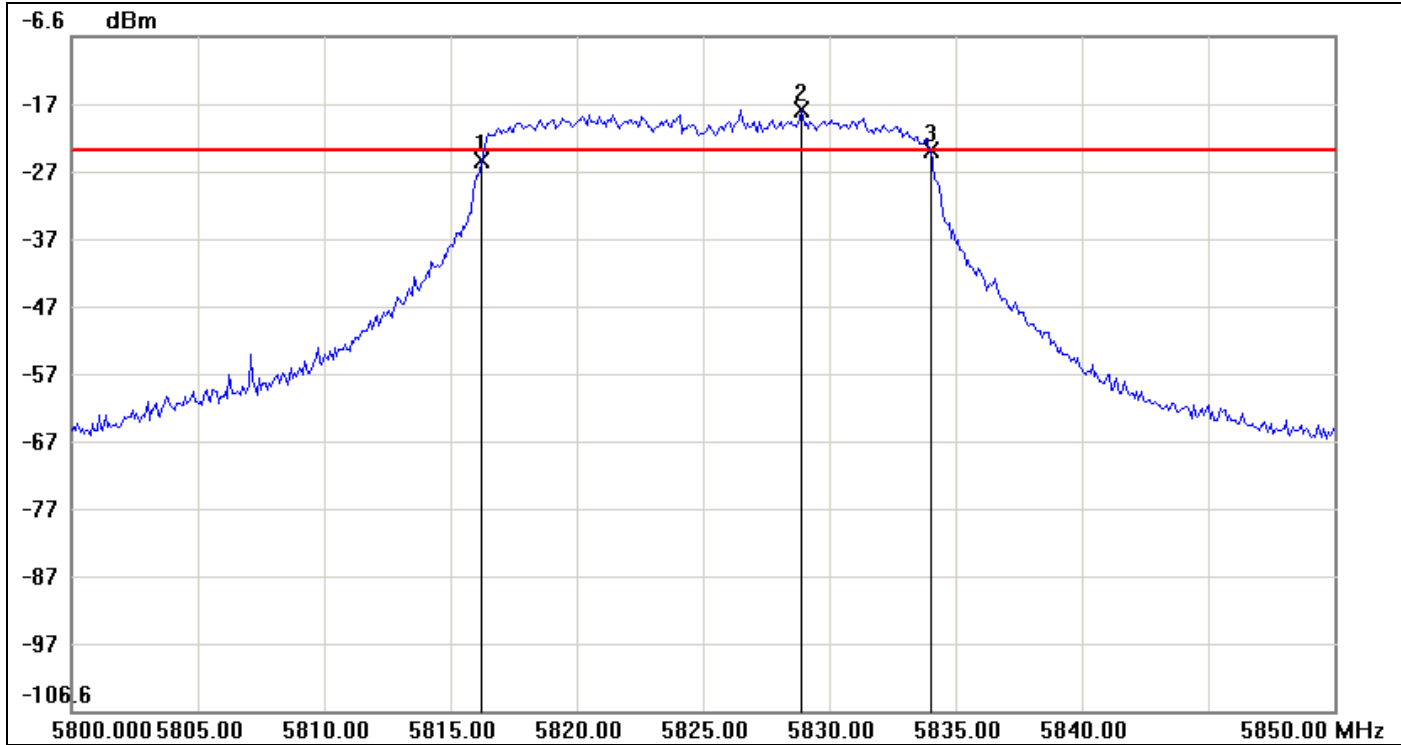

No.	Frequency(MHz)	Result(dBm)	Limit(dBm)	Margin(dBm)
1	5816.2500	-25.00	-23.36	-1.64
2	5828.9167	-17.36	-23.36	6.00
3	5834.0000	-23.52	-23.36	-0.16

No.		Δ Frequency(MHz)	Δ Level(dB)
1	mk3-mk1	17.75	1.48



IEEE 802.11n HT 20 mode / Chain 1

6dB Bandwidth (CH Low)

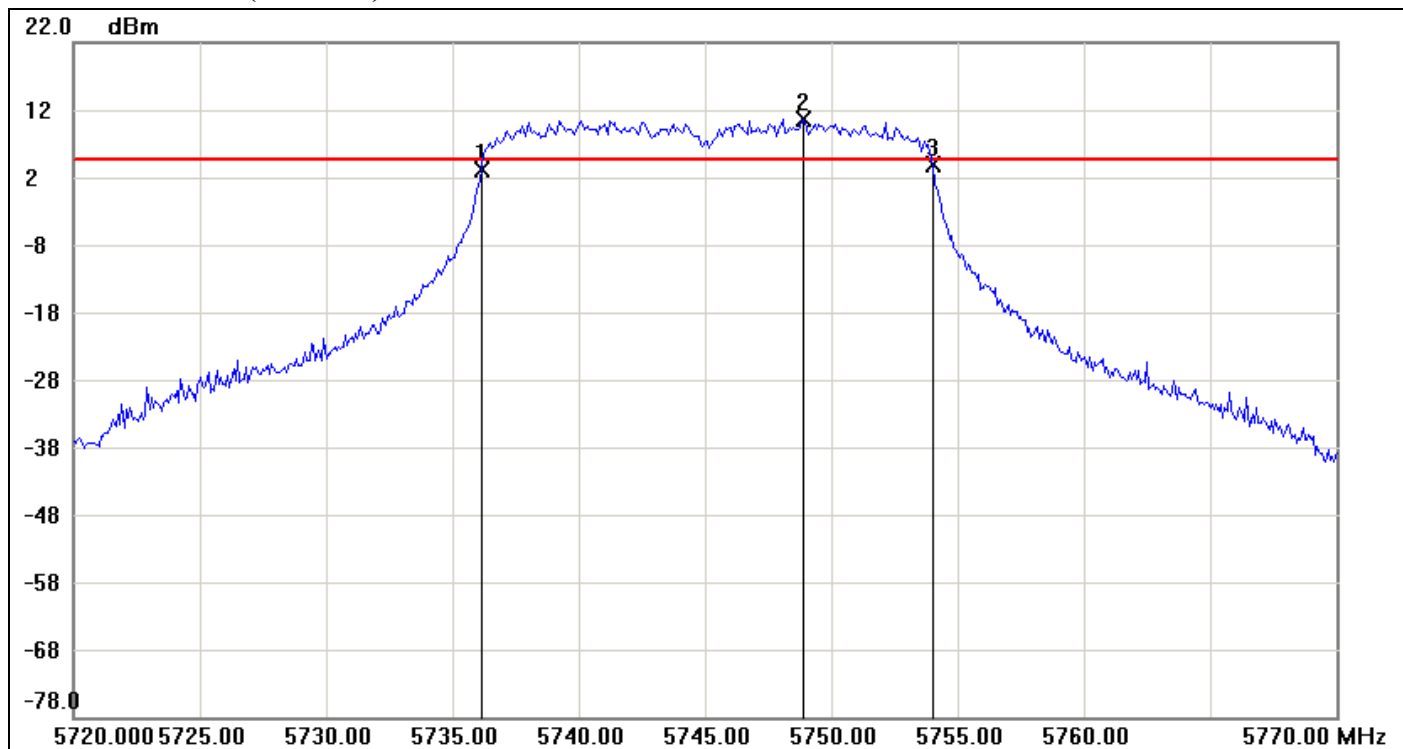

No.	Frequency(MHz)	Result(dBm)	Limit(dBm)	Margin(dBm)
1	5736.1667	3.15	4.65	-1.50
2	5748.9167	10.65	4.65	6.00
3	5754.0000	3.82	4.65	-0.83

No.		Δ Frequency(MHz)	Δ Level(dB)
1	mk3-mk1	17.8333	0.67



6dB Bandwidth (CH Mid)

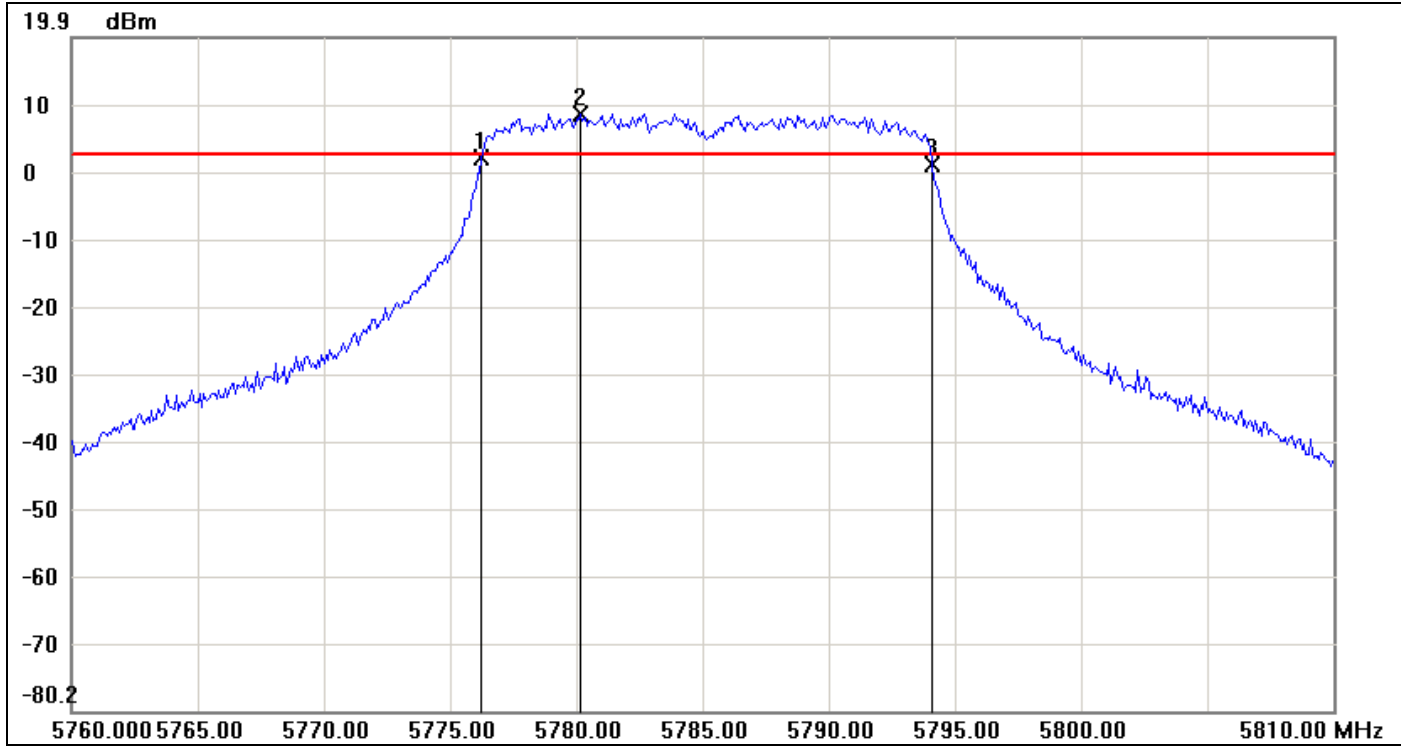

No.	Frequency(MHz)	Result(dBm)	Limit(dBm)	Margin(dBm)
1	5776.2500	2.10	2.51	-0.41
2	5780.1667	8.51	2.51	6.00
3	5794.0833	0.98	2.51	-1.53

No.		Δ Frequency(MHz)	Δ Level(dB)
1	mk3-mk1	17.8333	-1.12



6dB Bandwidth (CH High)

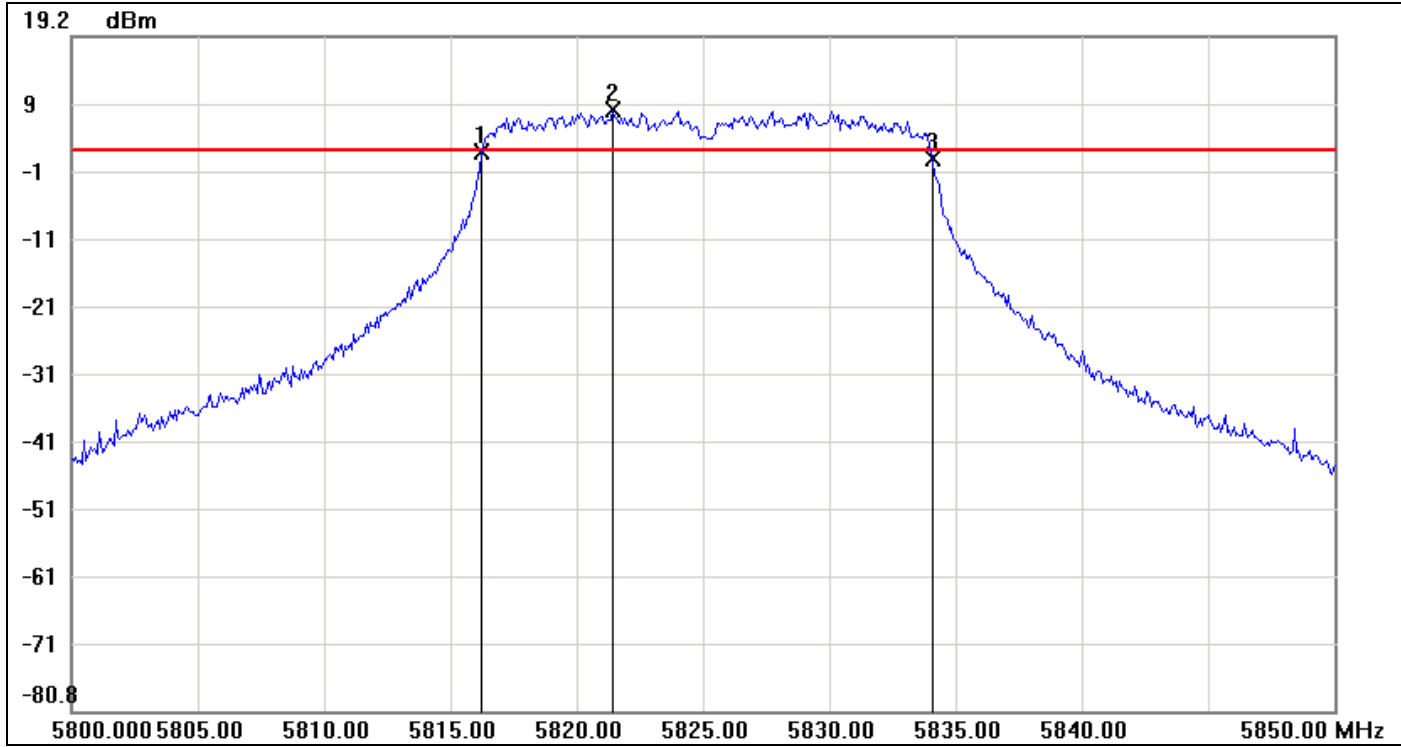

No.	Frequency(MHz)	Result(dBm)	Limit(dBm)	Margin(dBm)
1	5816.2500	2.02	2.31	-0.29
2	5821.4167	8.31	2.31	6.00
3	5834.0833	1.20	2.31	-1.11

No.		Δ Frequency(MHz)	Δ Level(dB)
1	mk3-mk1	17.8333	-0.82



IEEE 802.11n HT 40 mode / Chain 0

6dB Bandwidth (CH Low)

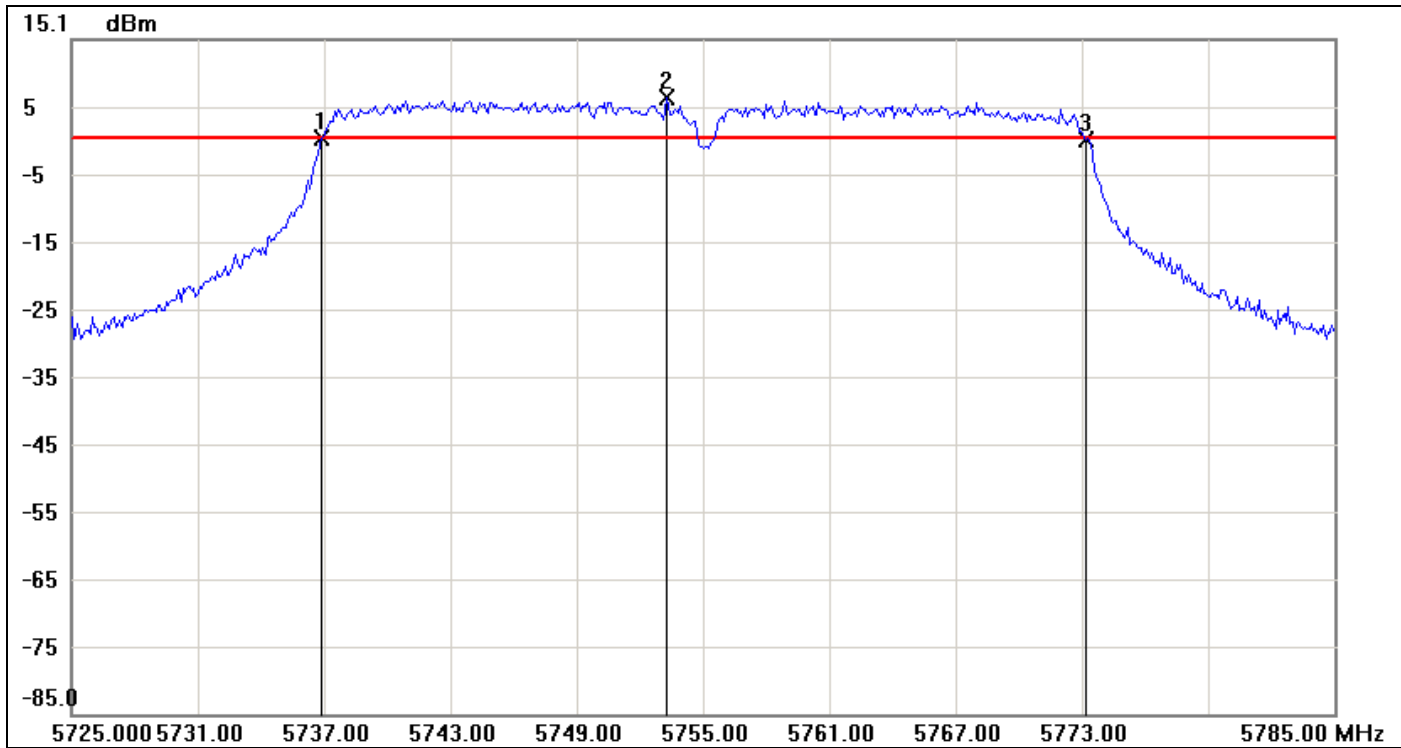

No.	Frequency(MHz)	Result(dBm)	Limit(dBm)	Margin(dBm)
1	5736.9000	0.33	0.44	-0.11
2	5753.3000	6.44	0.44	6.00
3	5773.2000	0.10	0.44	-0.34

No.		Δ Frequency(MHz)	Δ Level(dB)
1	mk3-mk1	36.3	-0.23



6dB Bandwidth (CH High)

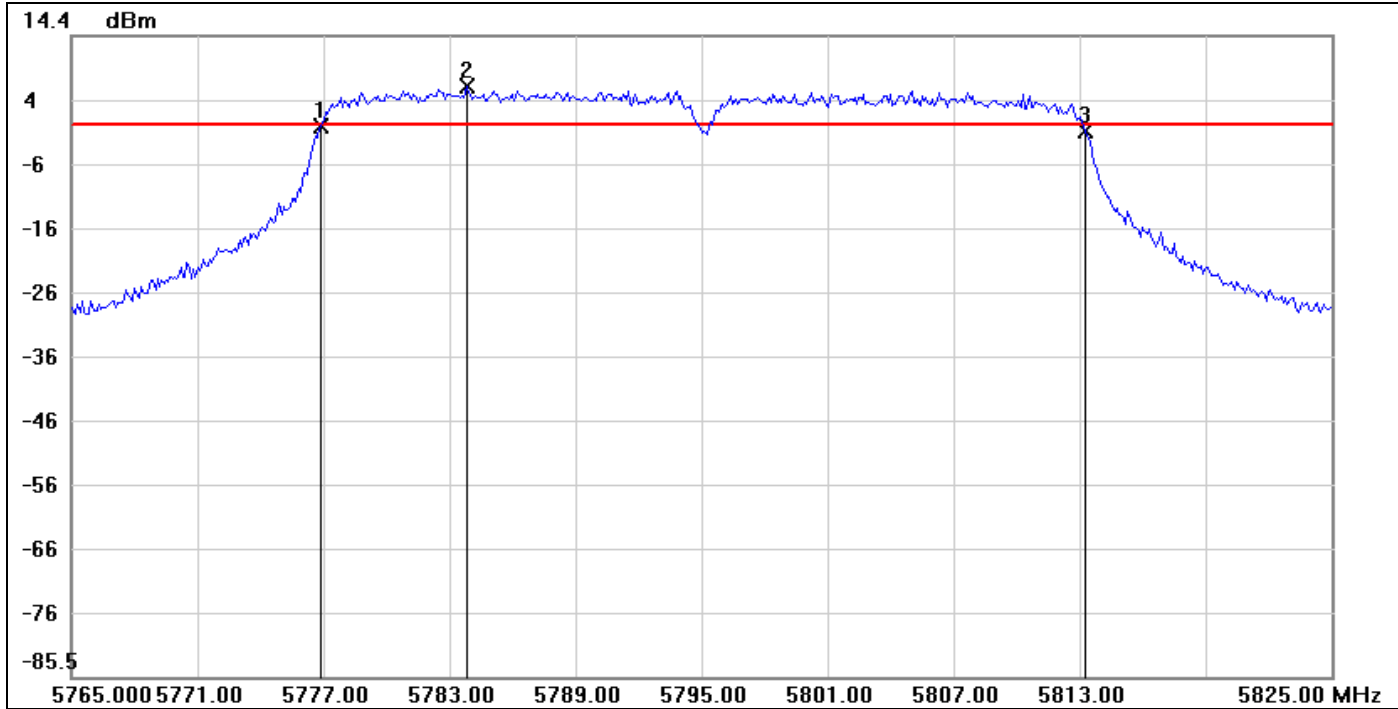

No.	Frequency(MHz)	Result(dBm)	Limit(dBm)	Margin(dBm)
1	5776.9000	0.40	0.48	-0.08
2	5783.8000	6.48	0.48	6.00
3	5813.3000	-0.52	0.48	-1.00

No.		Δ Frequency(MHz)	Δ Level(dB)
1	mk3-mk1	36.4	-0.92



IEEE 802.11n HT 40 mode / Chain 1

6dB Bandwidth (CH Low)

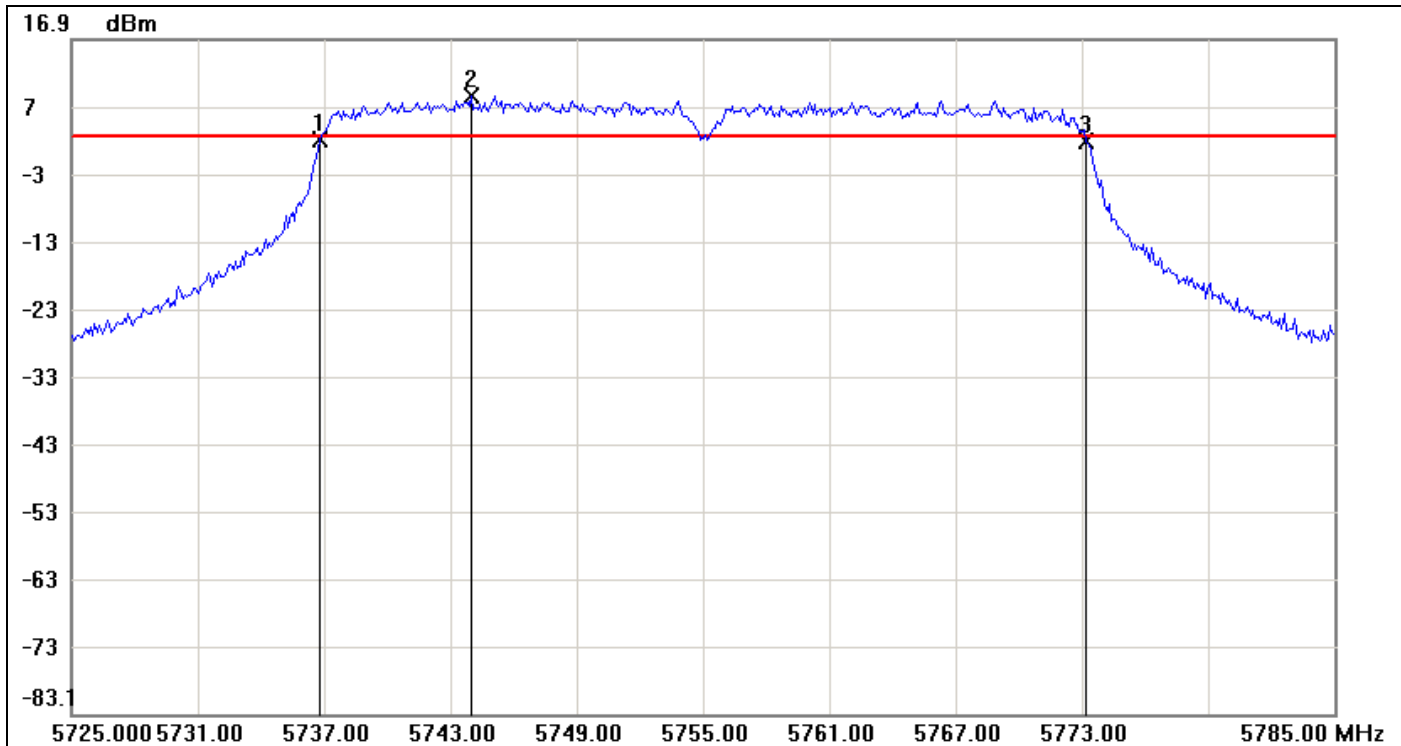

No.	Frequency(MHz)	Result(dBm)	Limit(dBm)	Margin(dBm)
1	5736.8000	2.01	2.54	-0.53
2	5744.0000	8.54	2.54	6.00
3	5773.2000	1.90	2.54	-0.64

No.		Δ Frequency(MHz)	Δ Level(dB)
1	mk3-mk1	36.4	-0.11



6dB Bandwidth (CH High)

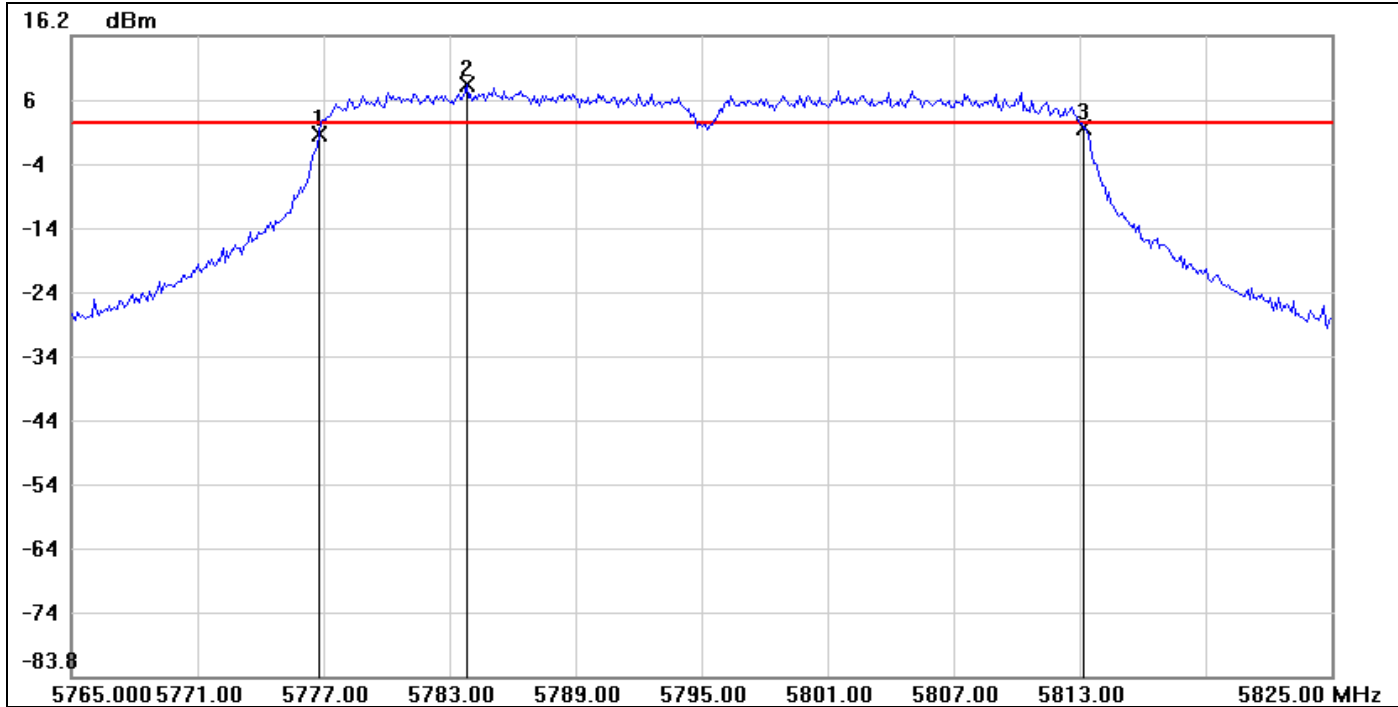

No.	Frequency(MHz)	Result(dBm)	Limit(dBm)	Margin(dBm)
1	5776.8000	0.86	2.46	-1.60
2	5783.8000	8.46	2.46	6.00
3	5813.2000	1.76	2.46	-0.70

No.		Δ Frequency(MHz)	Δ Level(dB)
1	mk3-mk1	36.4	0.9



7.2 PEAK POWER

LIMIT

The maximum peak output power of the intentional radiator shall not exceed the following:

1. According to §15.247(b)(3), for systems using digital modulation in the bands of 902-928 MHz, 2400-2483.5 MHz, and 5725-5850 MHz: 1 Watt.
2. According to §15.247(b)(4), the conducted output power limit specified in paragraph (b) of this section is based on the use of antennas with directional gains that do not exceed 6 dBi. Except as shown in paragraph (c) of this section, if transmitting antennas of directional gain greater than 6 dBi are used, the conducted output power from the intentional radiator shall be reduced below the stated values in paragraphs (b)(1), (b)(2), and (b)(3) of this section, as appropriate, by the amount in dB that the directional gain of the antenna exceeds 6 dBi.

Test Configuration

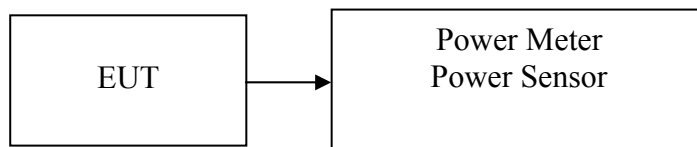

TEST PROCEDURE

The transmitter output is connected to the Power Meter. The Power Meter is set to the peak power detection.

TEST RESULTS

No non-compliance noted.

**Test Data****Test mode: IEEE 802.11a mode**

Channel	Frequency (MHz)	Output Power (dBm)	Output Power (W)	Limit (W)	Result
Low	5745	20.98	0.1253	0.14	PASS
Mid	5785	20.71	0.1178		PASS
High	5825	20.87	0.1222		PASS

Test mode: IEEE 802.11n HT 20 mode

Channel	Frequency (MHz)	Chain 0 Output Power (dBm)	Chain 1 Output Power (dBm)	Total Output Power (dBm)	Output Power (W)	Limit (W)	Result
Low	5745	15.05	14.97	18.02	0.0634	0.07	PASS
Mid	5785	15.19	14.82	18.02	0.0634		PASS
High	5825	15.08	14.73	17.92	0.0619		PASS

Test mode: IEEE 802.11n HT 40 mode

Channel	Frequency (MHz)	Chain 0 Output Power (dBm)	Chain 1 Output Power (dBm)	Total Output Power (dBm)	Output Power (W)	Limit (W)	Result
Low	5755	15.13	14.83	17.99	0.0630	0.07	PASS
High	5795	15.33	15.15	18.25	0.0668		PASS

Remark:

1. Total Output Power (w) = Chain 0 ($10^{(Output\ Power / 10) / 1000}$) + Chain 1 ($10^{(Output\ Power / 10) / 1000}$)
2. The maximum antenna gain is 14.53 dBi; therefore the reduction due to antenna gain is 8.53dB, so the limit is 21.47dBm.
3. The maximum antenna gain is 17.53dBi; therefore the reduction due to antenna gain is 11.53dB, so the limit is 18.47dBm.



7.3 PEAK POWER SPECTRAL DENSITY

LIMIT

1. According to §15.247(e), for digitally modulated systems, the power spectral density conducted from the intentional radiator to the antenna shall not be greater than 8 dBm in any 3 kHz band during any time interval of continuous transmission.
2. According to §15.247(f), the digital modulation operation of the hybrid system, with the frequency hopping turned off, shall comply with the power density requirements of paragraph (d) of this section.

Test Configuration

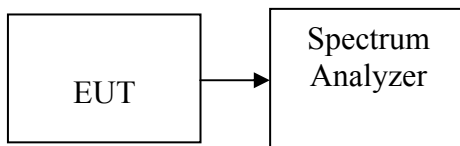

TEST PROCEDURE

The transmitter output is connected to a spectrum analyzer. Set the RBW = 100 kHz, VBW \geq 300 kHz, span to 1.5 times the DTS bandwidth, Detector = peak, Trace mode = max hold, Sweep = auto couple. Use the peak marker function to determine the maximum amplitude level within the RBW. If measured value exceeds limit, reduce RBW (no less than 3 kHz).

TEST RESULTS

No non-compliance noted



Test Data

Test mode: IEEE 802.11a mode

Channel	Frequency (MHz)	PPSD (dBm)	Limit (dBm)	Result
Low	5745	-7.11	-0.53	PASS
Mid	5785	-10.08		PASS
High	5825	-8.55		PASS

Test mode: IEEE 802.11n HT 20 mode

Channel	Frequency (MHz)	Chain 0 PPSD (dBm)	Chain 1 PPSD (dBm)	PPSD (dBm)	Limit (dBm)	Result
Low	5745	-10.53	-18.24	-9.85	-3.53	PASS
Mid	5785	-15.96	-20.29	-14.60		PASS
High	5825	-11.84	-16.77	-10.63		PASS

Test mode: IEEE 802.11n HT 40 mode

Channel	Frequency (MHz)	Chain 0 PPSD (dBm)	Chain 1 PPSD (dBm)	PPSD (dBm)	Limit (dBm)	Result
Low	5755	-10.49	-15.57	-9.32	-3.53	PASS
High	5795	-15.57	-17.33	-13.35		PASS

Remark:

1. Total PPSD (dBm) = $10 * \text{LOG}(10^{(\text{Chain 0 PPSD} / 10)} + 10^{(\text{Chain 1 PPSD} / 10)})$
2. The maximum antenna gain is 14.53 dBi; therefore the reduction due to antenna gain is 8.53dB, so the limit is -0.53 dBm.
3. The maximum antenna gain is 17.53dBi; therefore the reduction due to antenna gain is 11.53dB, so the limit is -3.53 dBm.



Test Plot

IEEE 802.11a mode

PPSD (CH Low)

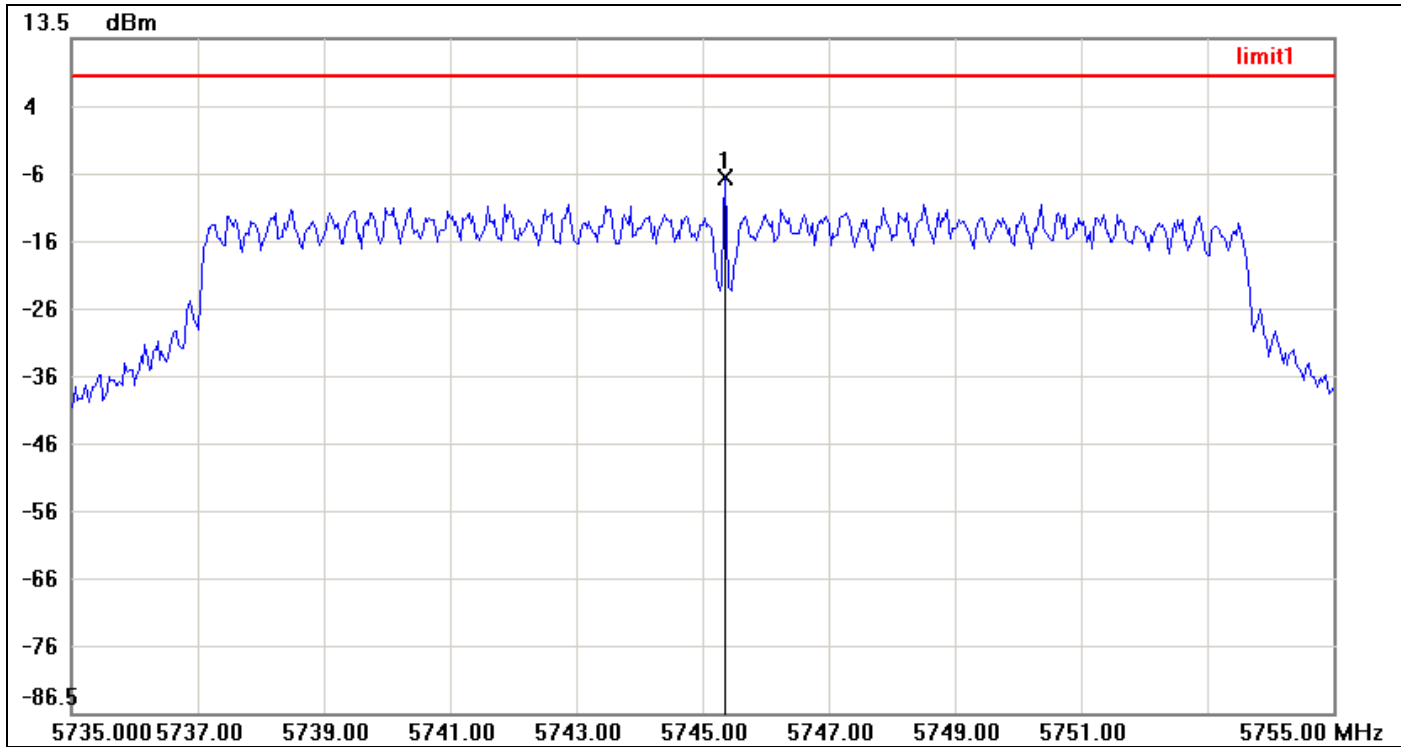

No.	Frequency(MHz)	Result(dBm)	Limit(dBm)	Margin(dBm)
1	5745.3667	-7.11	-0.47	-6.64



PPSD (CH Mid)

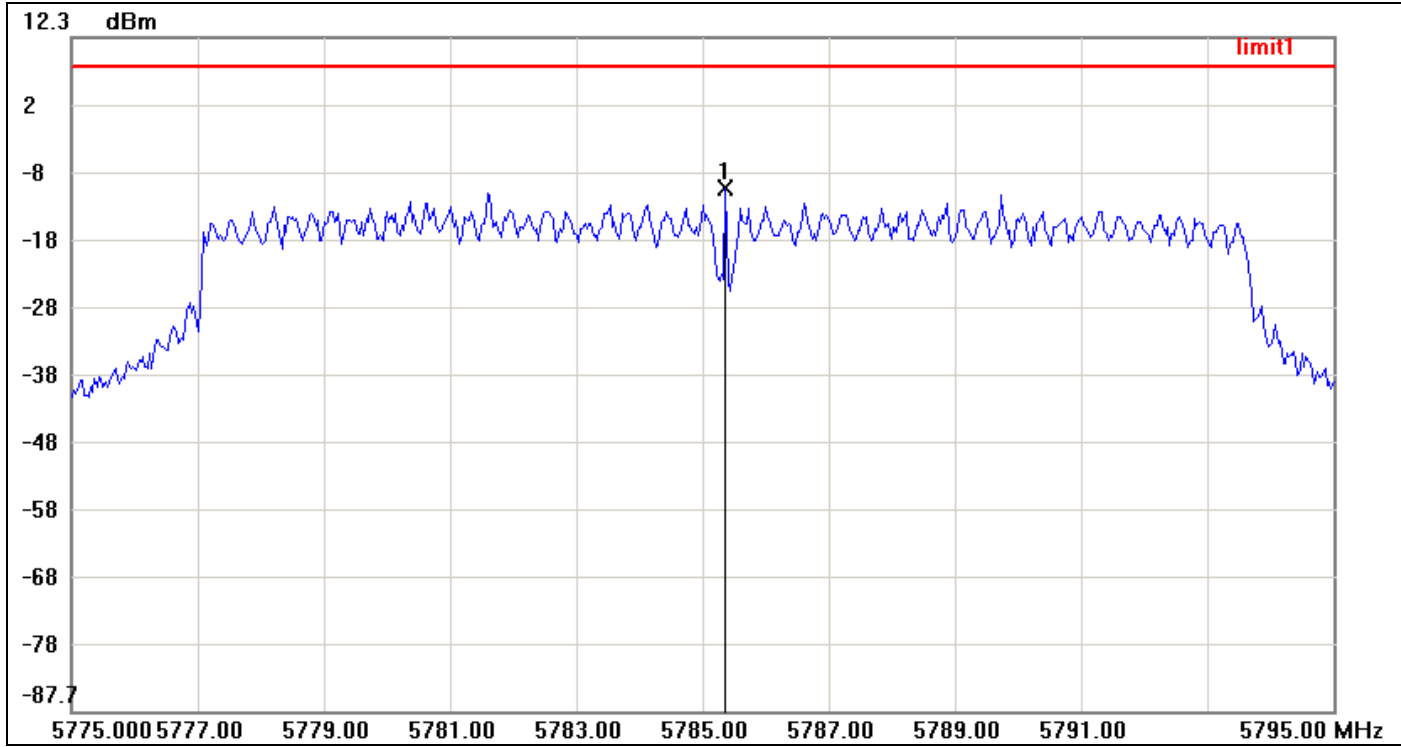

No.	Frequency(MHz)	Result(dBm)	Limit(dBm)	Margin(dBm)
1	5785.3667	-10.08	-0.47	-9.61



PPSD (CH High)

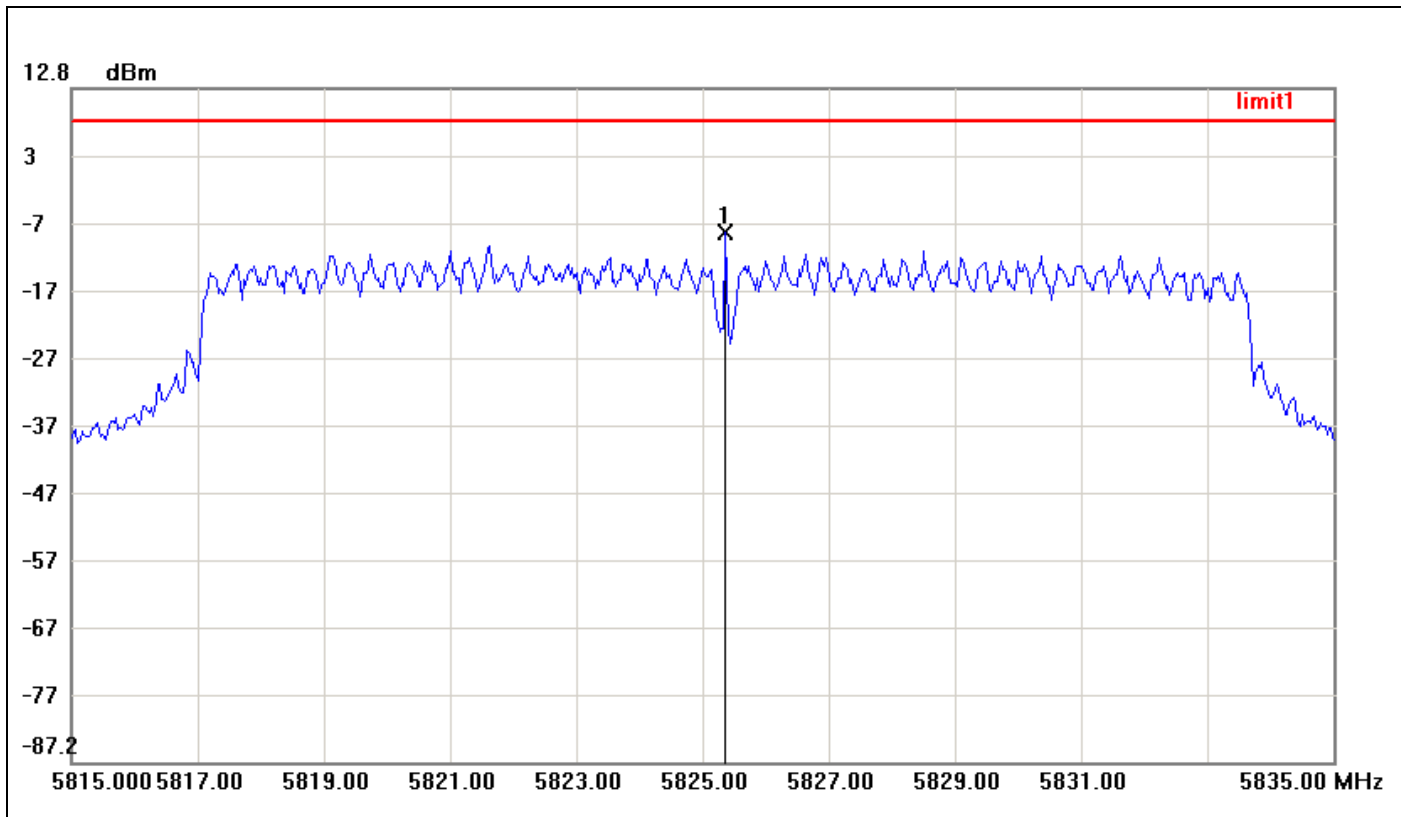

No.	Frequency(MHz)	Result(dBm)	Limit(dBm)	Margin(dBm)
1	5825.3667	-8.55	-0.47	-8.08



IEEE 802.11n HT 20 mode / Chain 0

PPSD (CH Low)

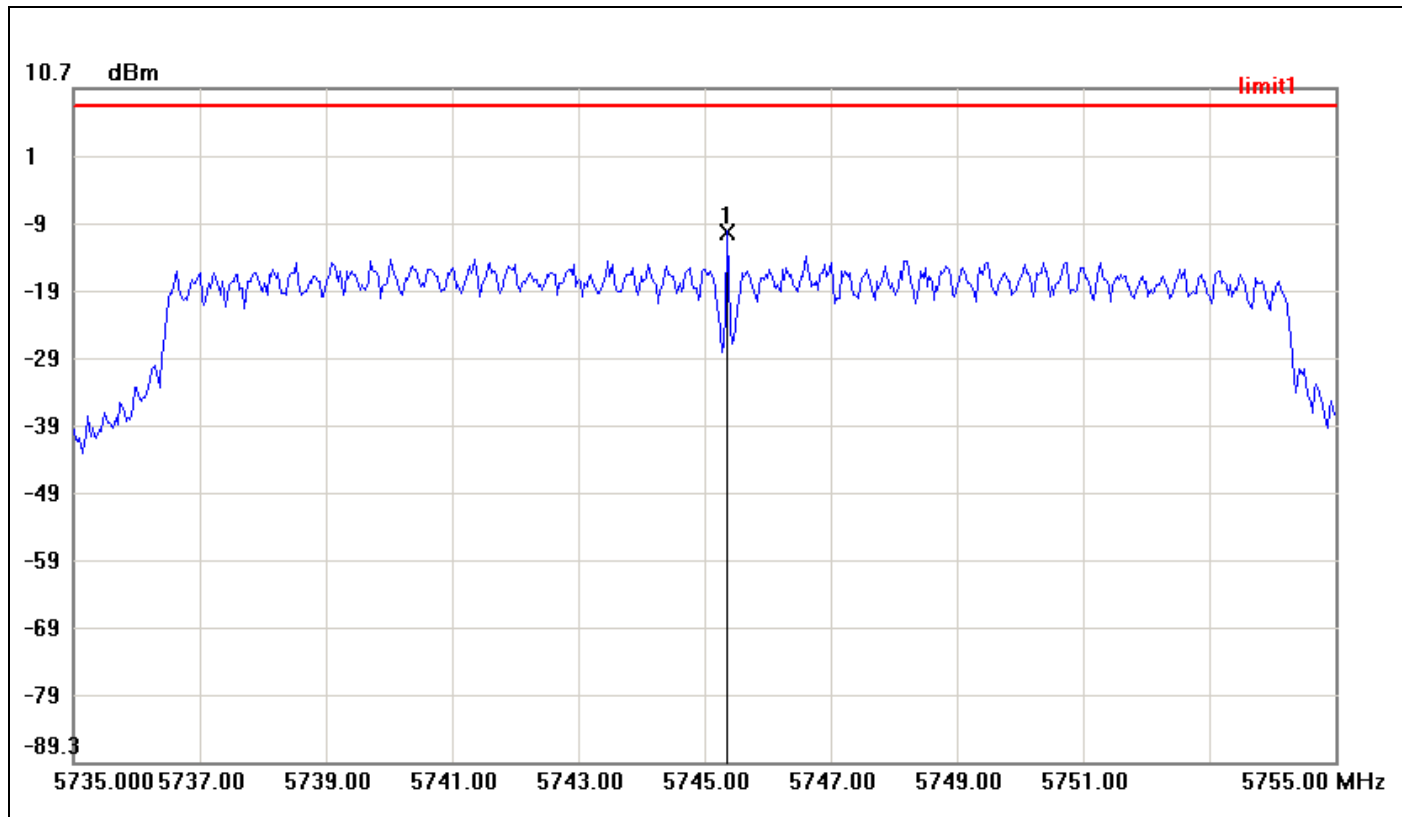

No.	Frequency(MHz)	Result(dBm)	Limit(dBm)	Margin(dBm)
1	5745.3667	-10.53	-3.47	-7.06



PPSD (CH Mid)

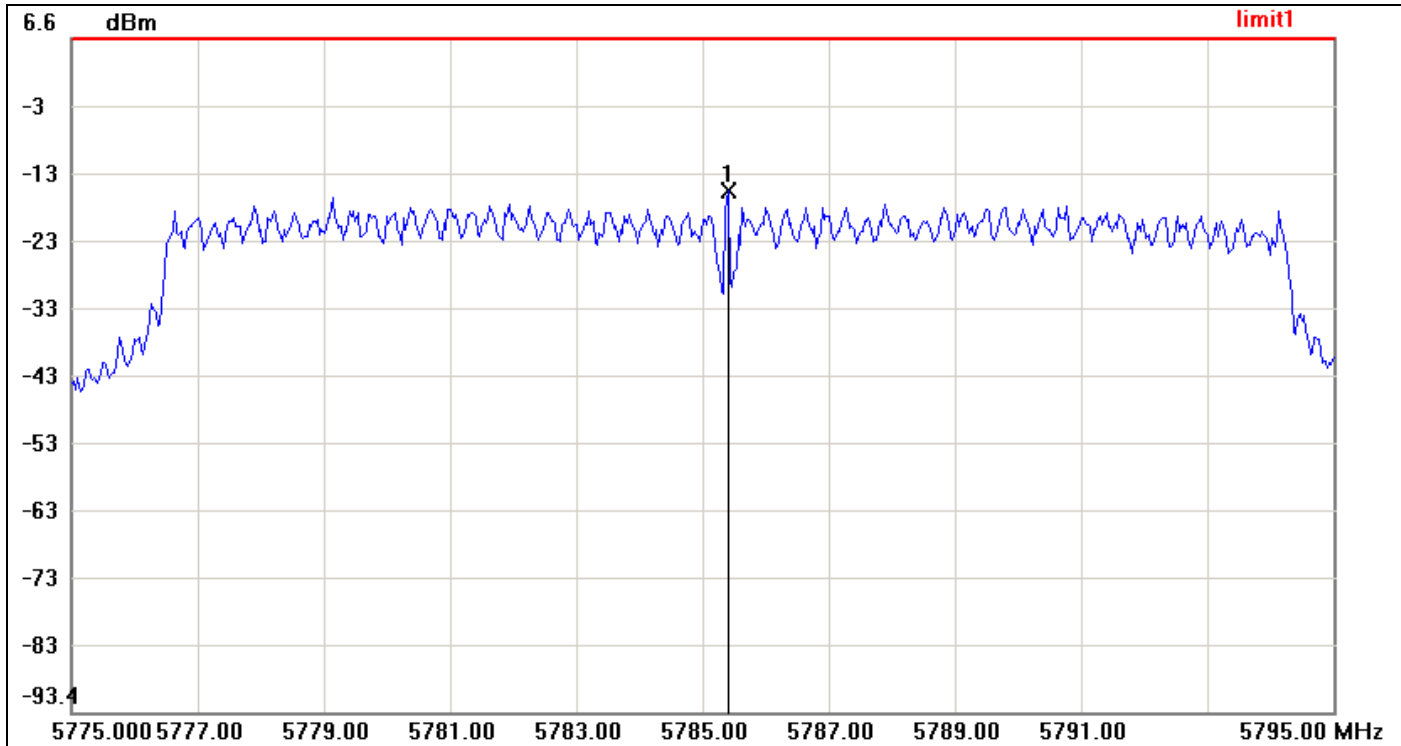

No.	Frequency(MHz)	Result(dBm)	Limit(dBm)	Margin(dBm)
1	5785.4000	-15.96	-3.47	-12.49



PPSD (CH High)

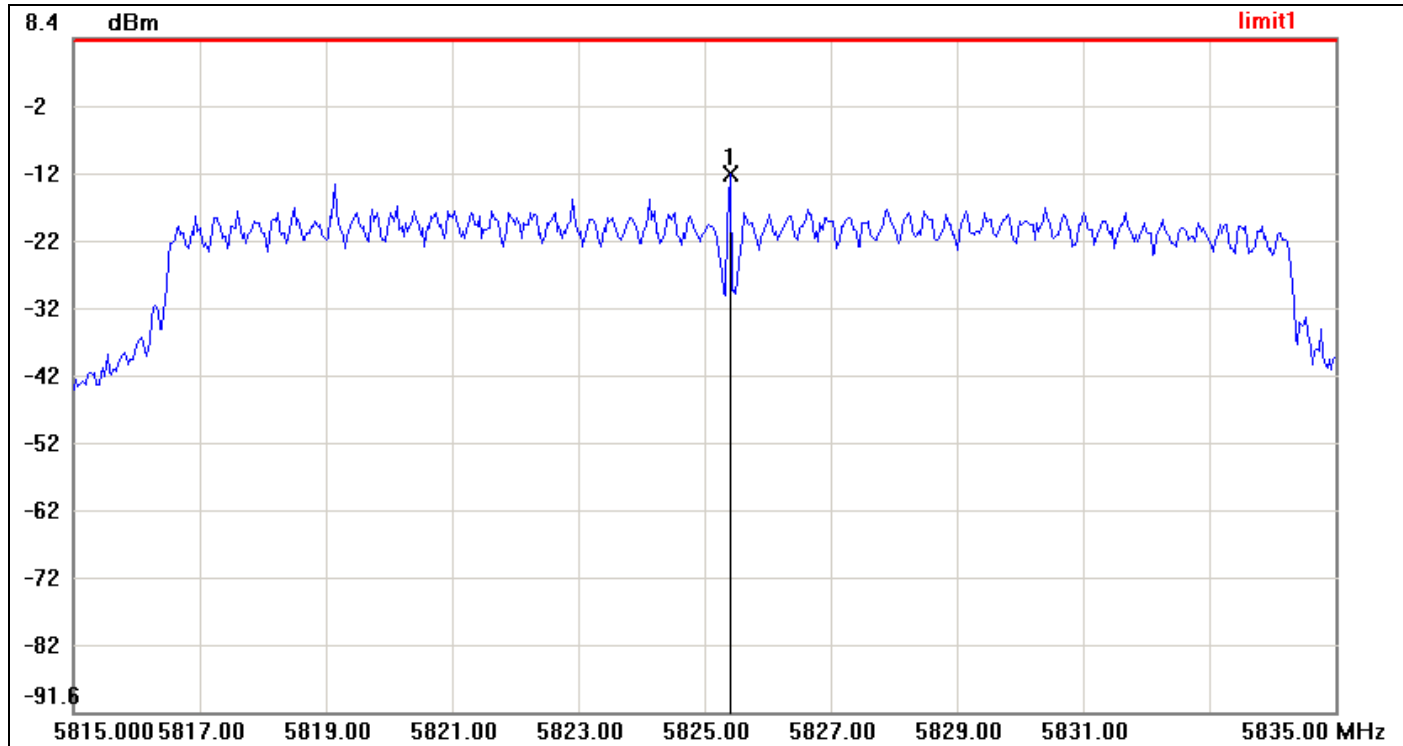

No.	Frequency(MHz)	Result(dBm)	Limit(dBm)	Margin(dBm)
1	5825.4000	-11.84	-3.47	-8.37



IEEE 802.11n HT 20 mode / Chain 1

PPSD (CH Low)

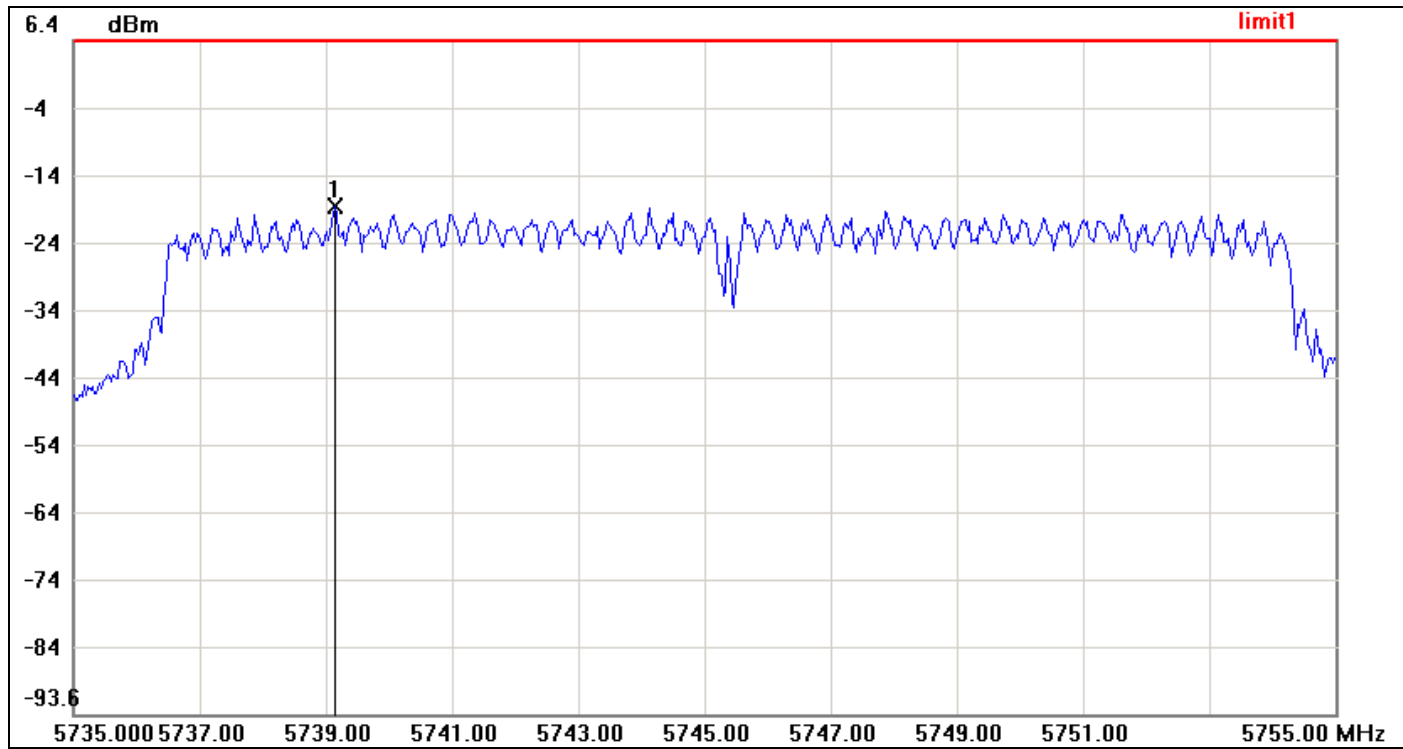

No.	Frequency(MHz)	Result(dBm)	Limit(dBm)	Margin(dBm)
1	5739.1333	-18.24	-3.47	-14.77



PPSD (CH Mid)

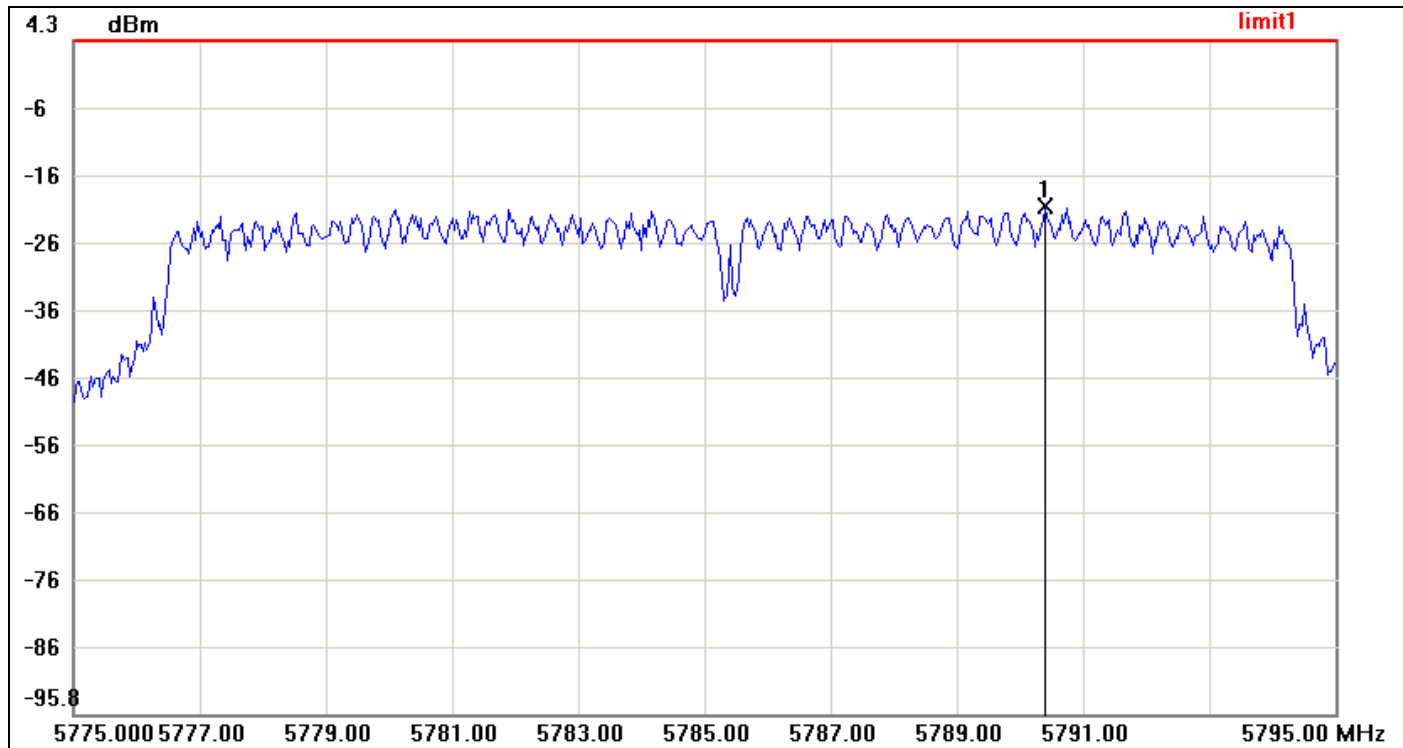

No.	Frequency(MHz)	Result(dBm)	Limit(dBm)	Margin(dBm)
1	5790.4000	-20.29	-3.47	-16.82



PPSD (CH High)

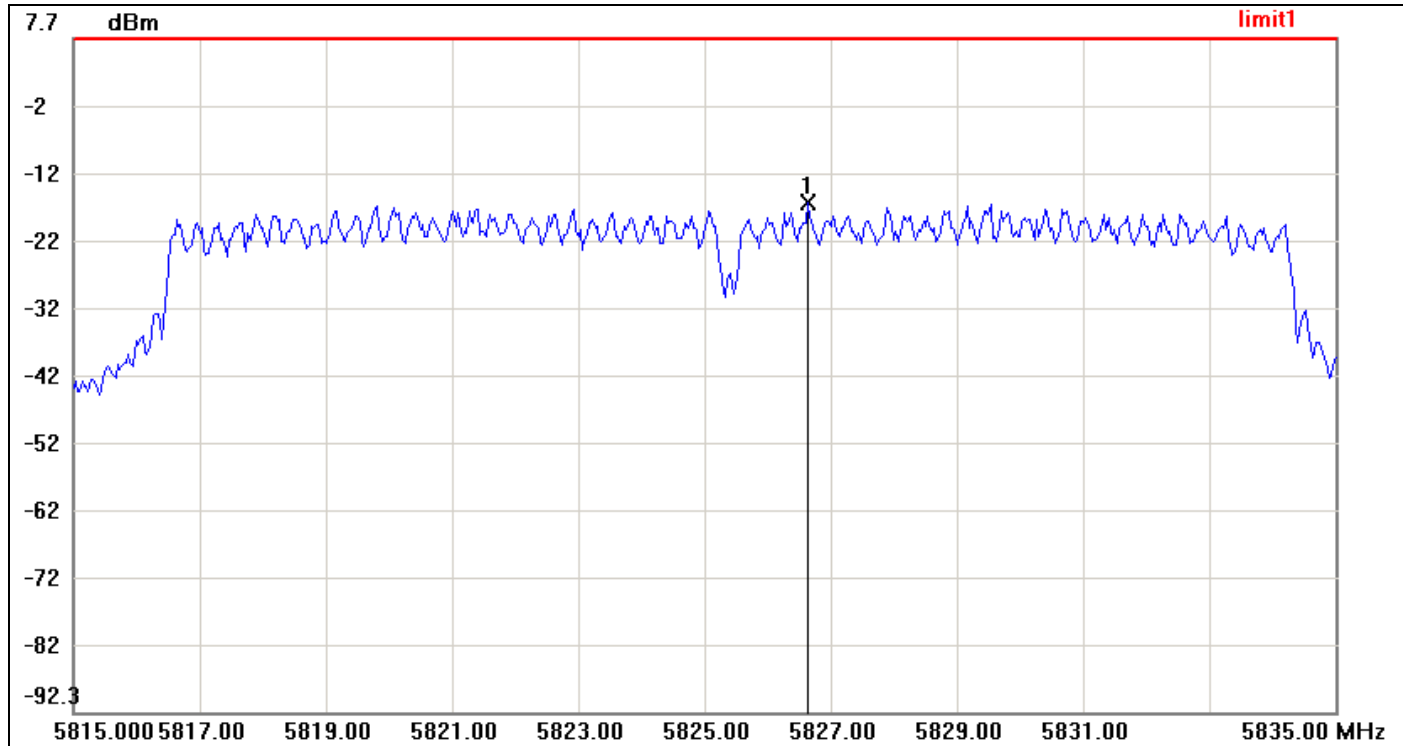

No.	Frequency(MHz)	Result(dBm)	Limit(dBm)	Margin(dBm)
1	5826.6333	-16.77	-3.47	-13.3



IEEE 802.11n HT 40 mode / Chain 0

PPSD (CH Low)

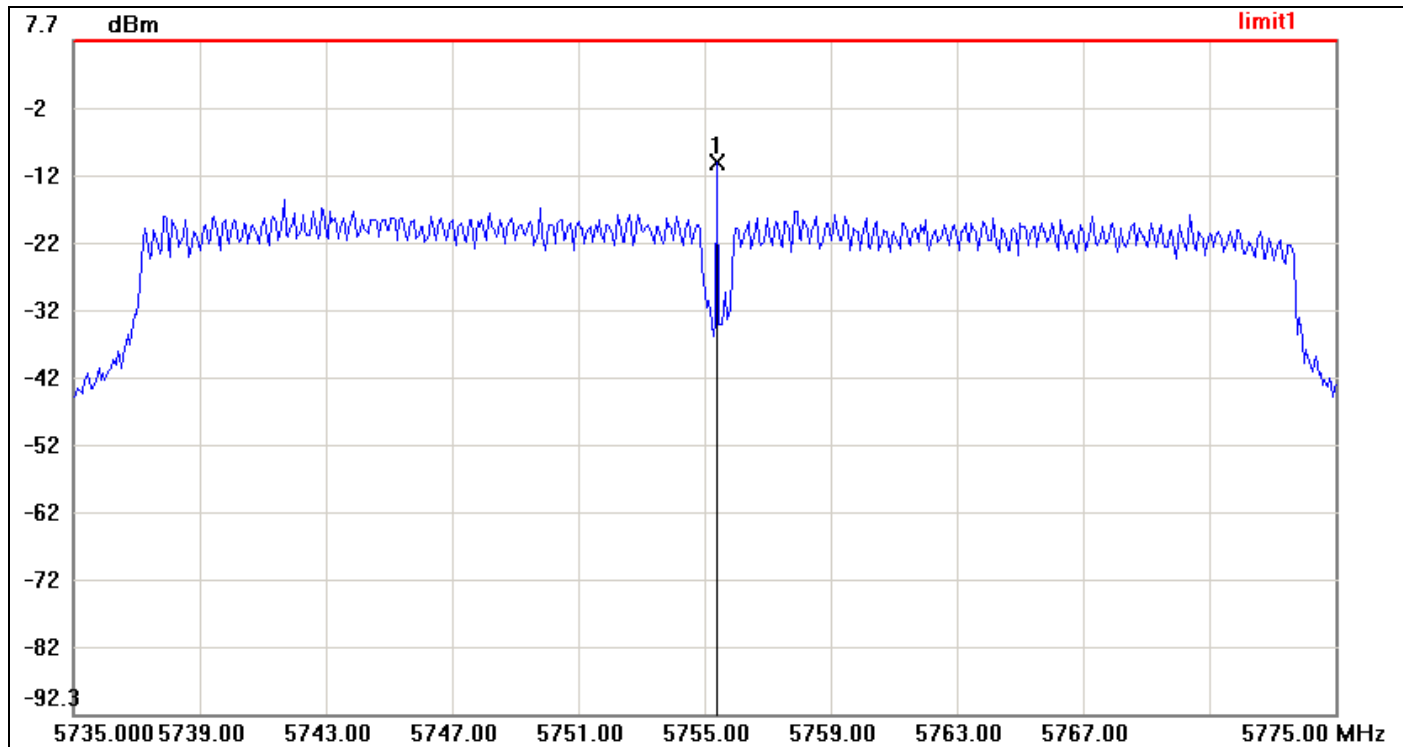

No.	Frequency(MHz)	Result(dBm)	Limit(dBm)	Margin(dBm)
1	5755.4000	-10.49	-3.47	-7.02



PPSD (CH High)

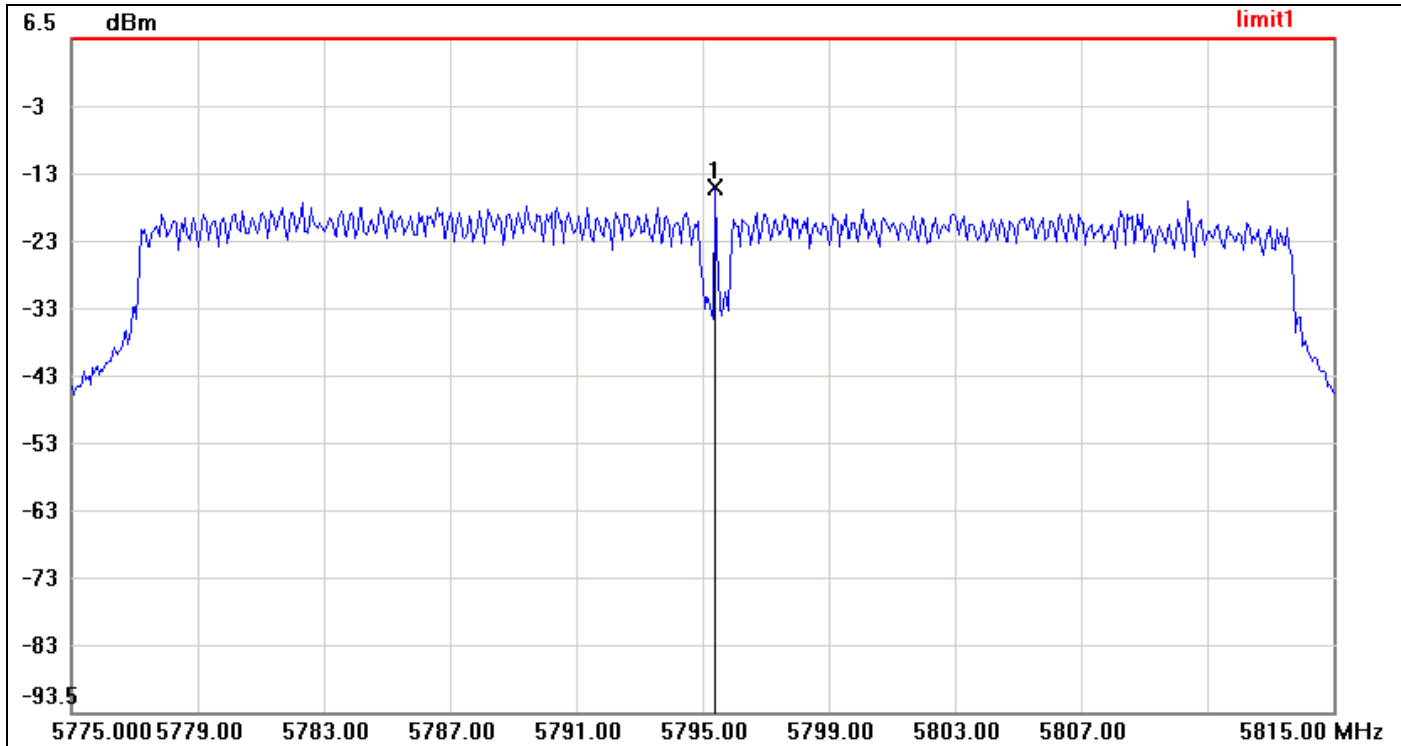

No.	Frequency(MHz)	Result(dBm)	Limit(dBm)	Margin(dBm)
1	5795.4000	-15.57	-3.47	-12.1



IEEE 802.11n HT 40 mode / Chain 1

PPSD (CH Low)

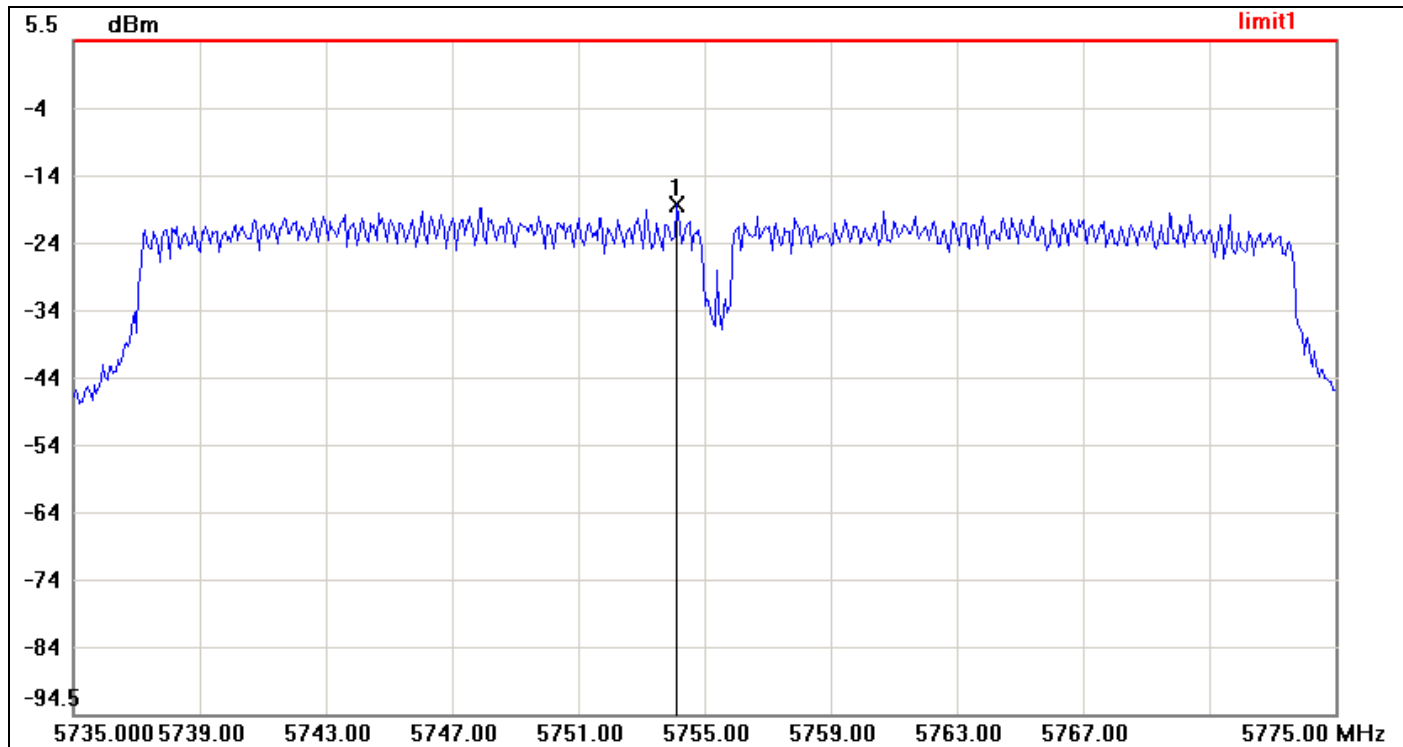

No.	Frequency(MHz)	Result(dBm)	Limit(dBm)	Margin(dBm)
1	5754.1333	-18.76	-3.47	-15.29



PPSD (CH High)

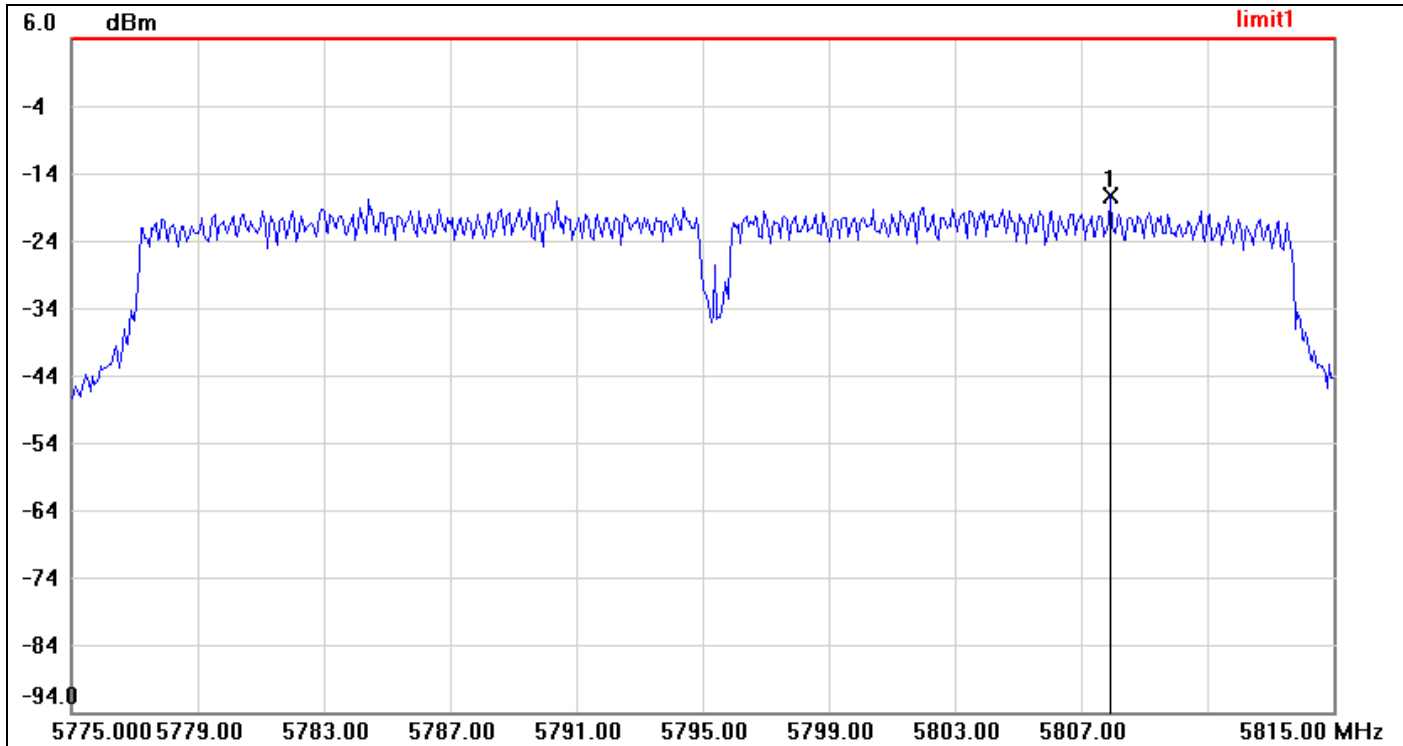

No.	Frequency(MHz)	Result(dBm)	Limit(dBm)	Margin(dBm)
1	5807.9333	-17.33	-3.47	-13.86



7.4 SPURIOUS EMISSIONS

7.4.1 Conducted Measurement

LIMIT

According to §15.247(d) & RSS-210 §A8.5, in any 100 kHz bandwidth outside the frequency bands in which the spread spectrum intentional radiator is operating, the radio frequency power that is produced by the intentional radiator shall be at least 20 dB below that in the 100 kHz bandwidth within the band that contains the highest level of the desired power, based on either an RF conducted or a radiated measurement, provided the transmitter demonstrates compliance with the peak conducted power limits. In addition, radiated emissions which fall in the restricted bands, as defined in §15.205(a), must also comply with the radiated emission limits specified in 15.209(a) (see Section 15.205(c)).

Test Configuration

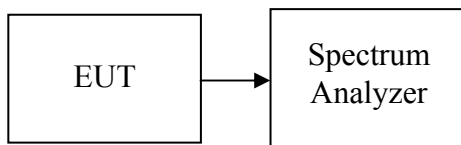

TEST PROCEDURE

Conducted RF measurements of the transmitter output were made to confirm that the EUT antenna port conducted emissions meet the specified limit and to identify any spurious signals that require further investigation or measurements on the radiated emissions site.

The transmitter output is connected to the spectrum analyzer. The resolution bandwidth is set to 100 kHz. The video bandwidth is set to 100 kHz.

Measurements are made over the 30MHz to 26GHz range for IEEE 802.11b/g, 30MHz to 40GHz range for IEEE 802.11a with the transmitter set to the lowest, middle, and highest channels.

TEST RESULTS

No non-compliance noted



Test Plot

IEEE 802.11a mode

CH Low

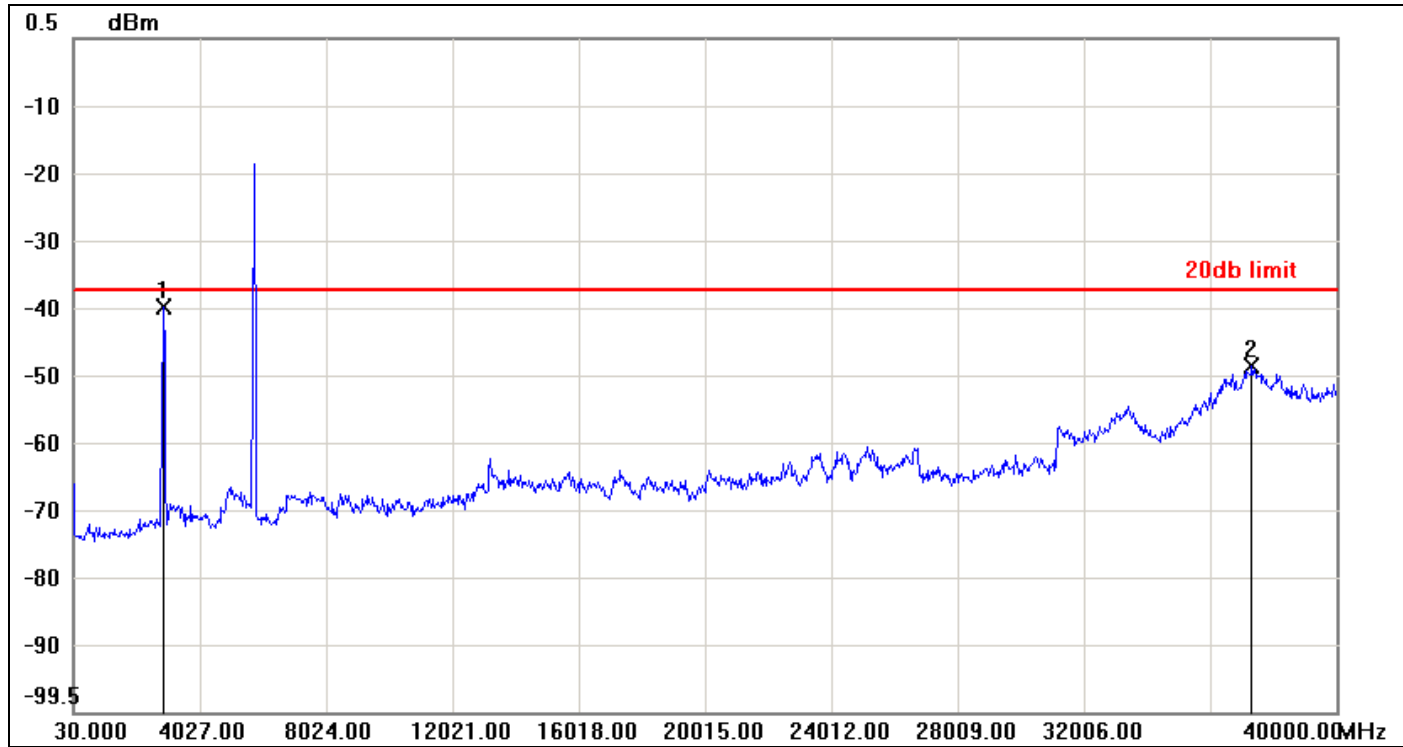

No.	Frequency(MHz)	Result(dBm)	Limit(dBm)	Margin(dBm)
1	2867.8700	-39.46	-36.90	-2.56
2	37322.0100	-48.25	-36.90	-11.35



CH Mid

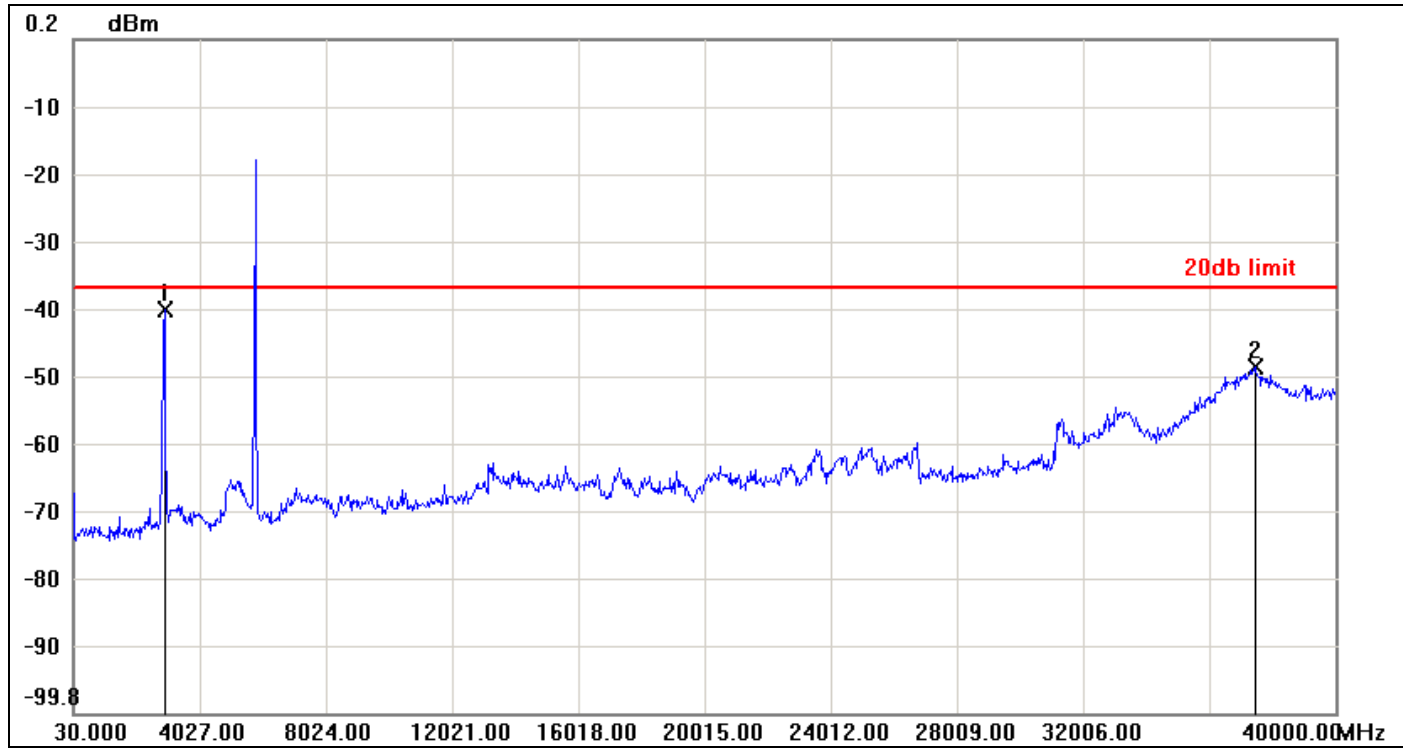

No.	Frequency(MHz)	Result(dBm)	Limit(dBm)	Margin(dBm)
1	2907.8400	-39.92	-36.70	-3.22
2	37441.9200	-48.44	-36.70	-11.74



CH High

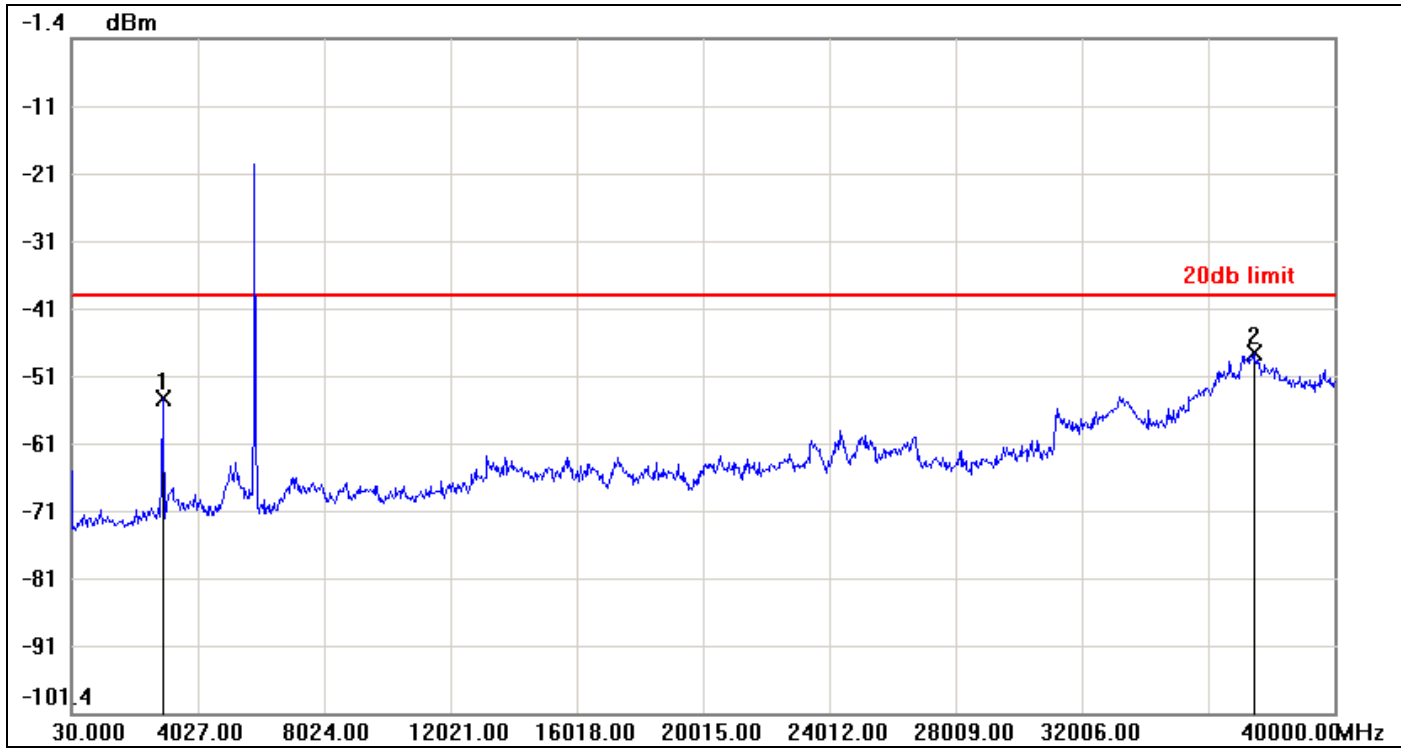

No.	Frequency(MHz)	Result(dBm)	Limit(dBm)	Margin(dBm)
1	2907.8400	-54.70	-39.50	-15.20
2	37441.9200	-48.09	-39.50	-8.59



IEEE 802.11n HT 20 mode / Chain 0

CH Low

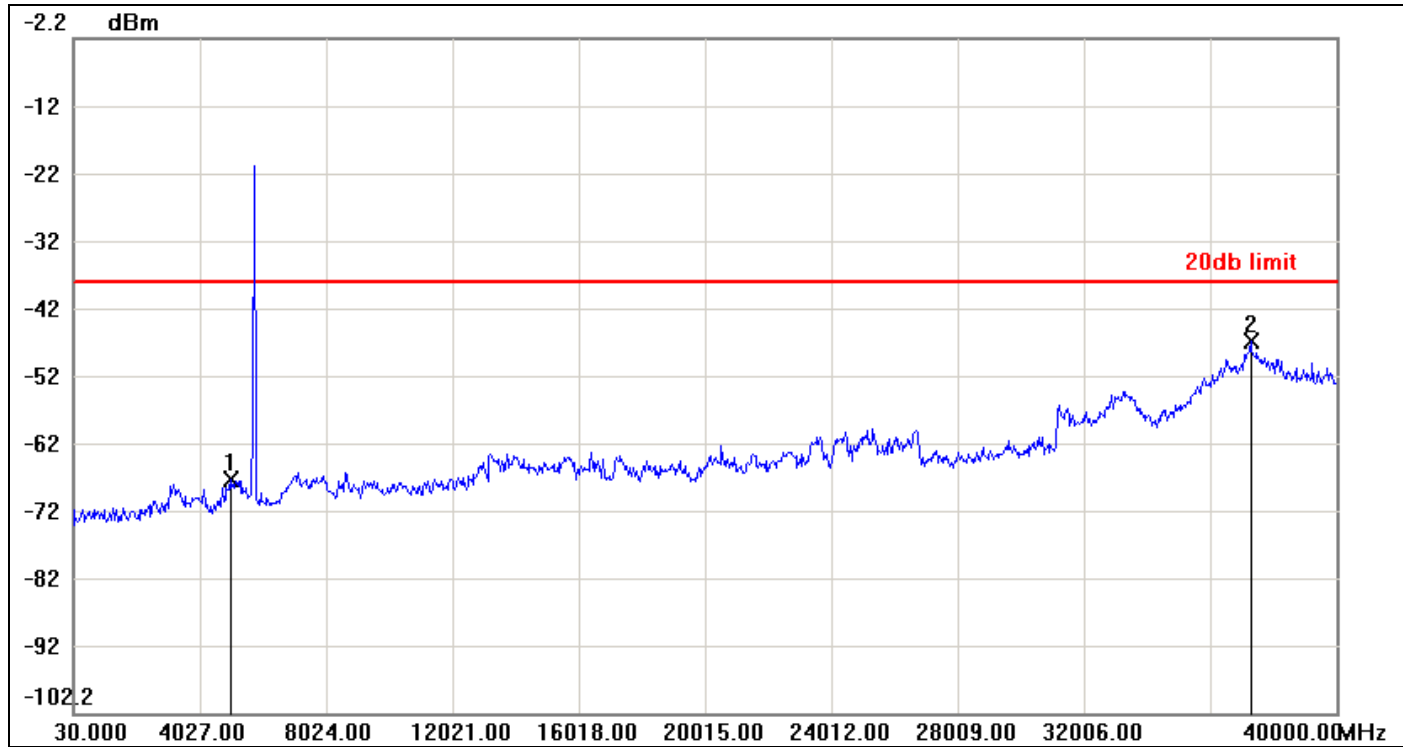

No.	Frequency(MHz)	Result(dBm)	Limit(dBm)	Margin(dBm)
1	4986.2800	-67.62	-38.28	-29.34
2	37282.0400	-47.13	-38.28	-8.85



CH Mid

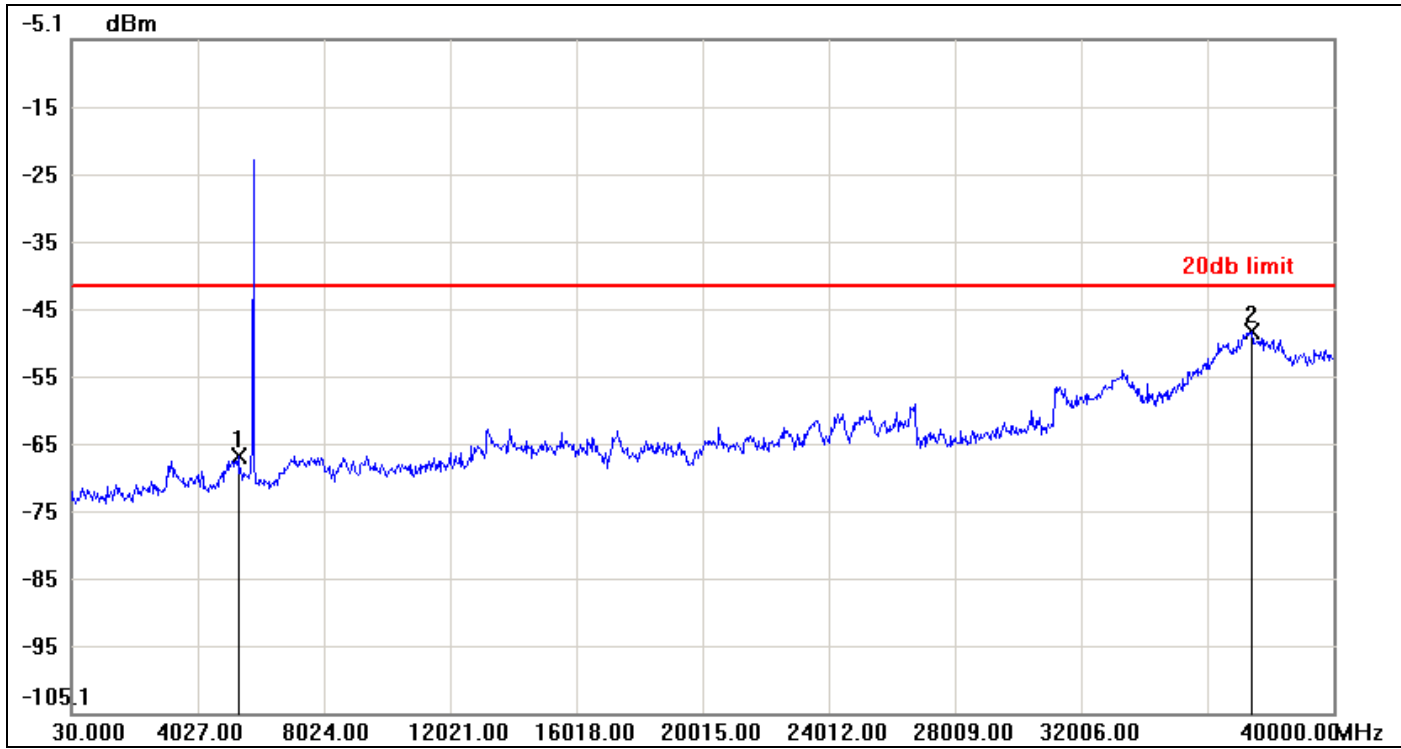

No.	Frequency(MHz)	Result(dBm)	Limit(dBm)	Margin(dBm)
1	5306.0400	-66.93	-41.84	-25.09
2	37401.9500	-48.50	-41.84	-6.66



CH High

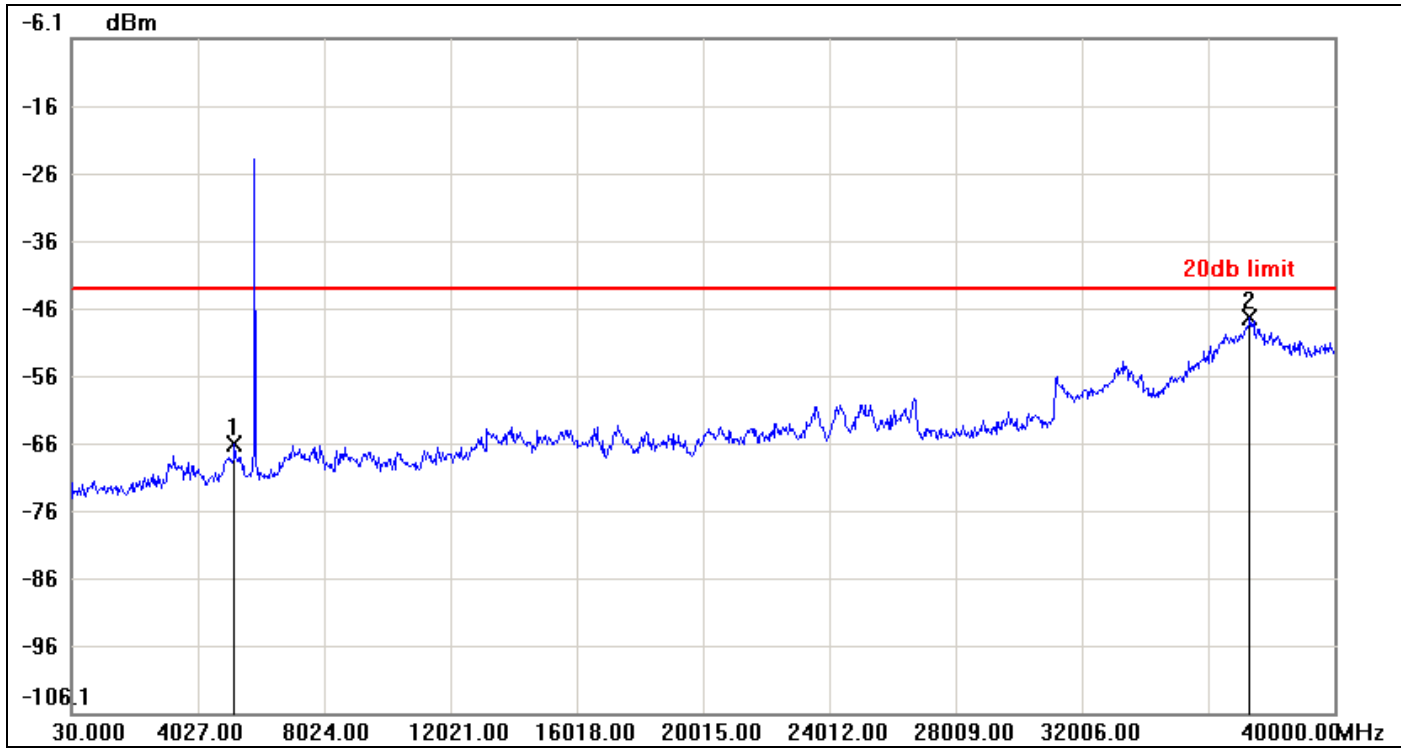

No.	Frequency(MHz)	Result(dBm)	Limit(dBm)	Margin(dBm)
1	5186.1300	-66.35	-43.22	-23.13
2	37322.0100	-47.53	-43.22	-4.31



IEEE 802.11n HT 20 mode / Chain 1

CH Low

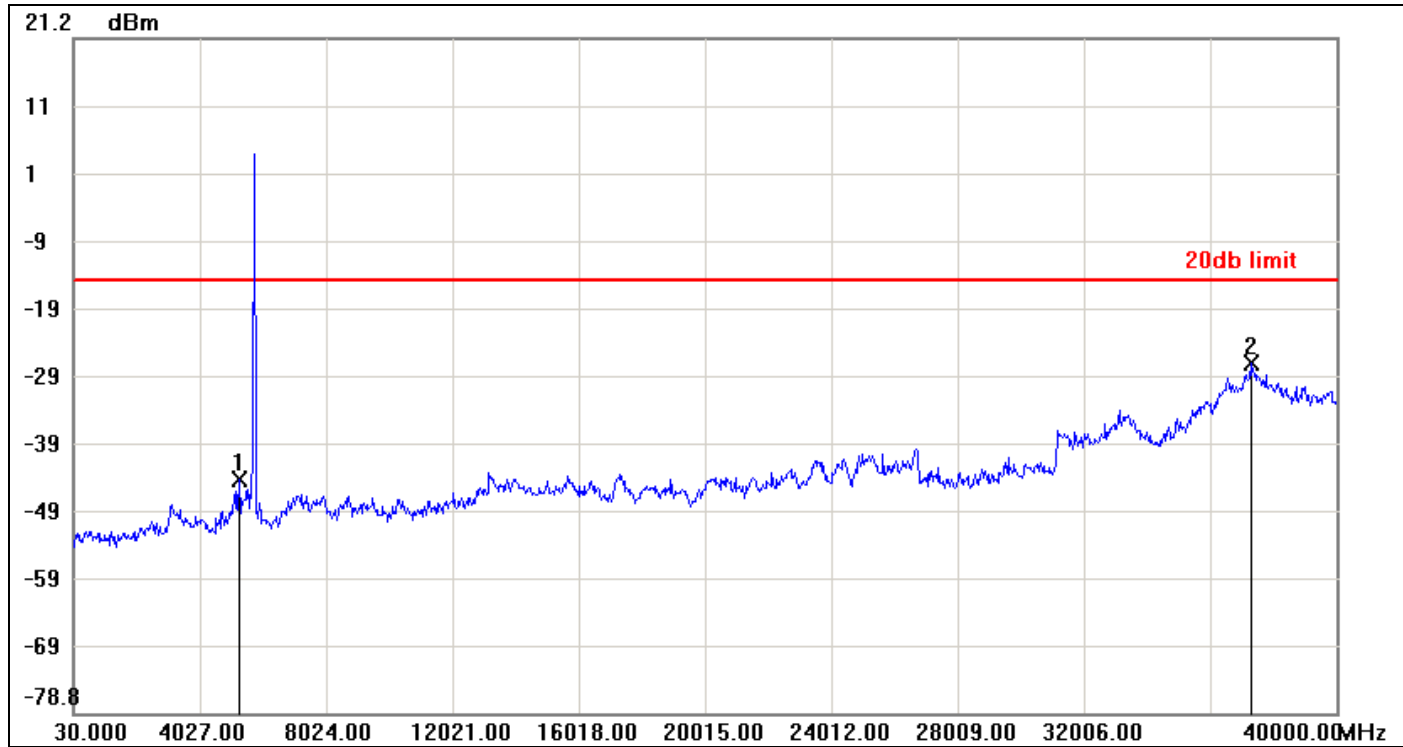

No.	Frequency(MHz)	Result(dBm)	Limit(dBm)	Margin(dBm)
1	5266.0700	-44.15	-14.79	-29.36
2	37282.0400	-27.05	-14.79	-12.26



CH Mid

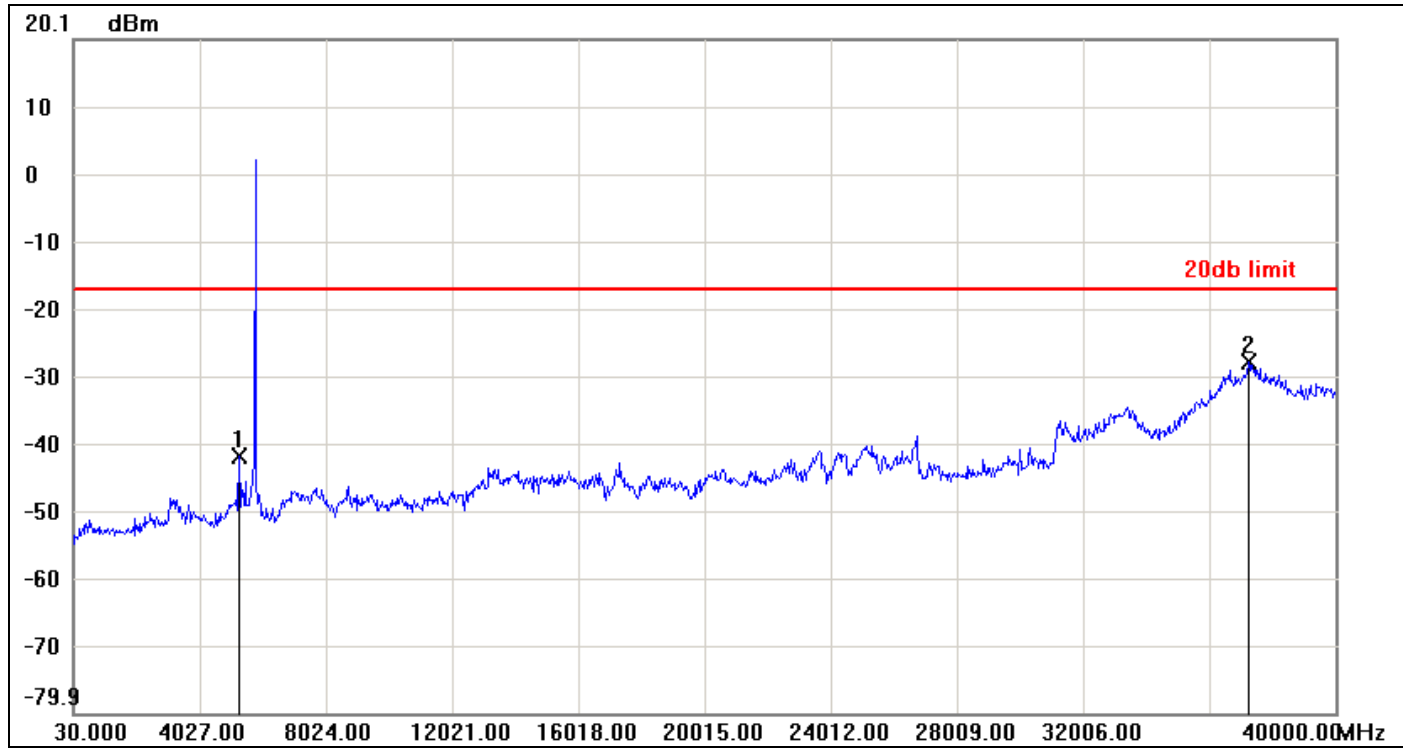

No.	Frequency(MHz)	Result(dBm)	Limit(dBm)	Margin(dBm)
1	5266.0700	-41.83	-16.93	-24.90
2	37242.0700	-27.74	-16.93	-10.81



CH High

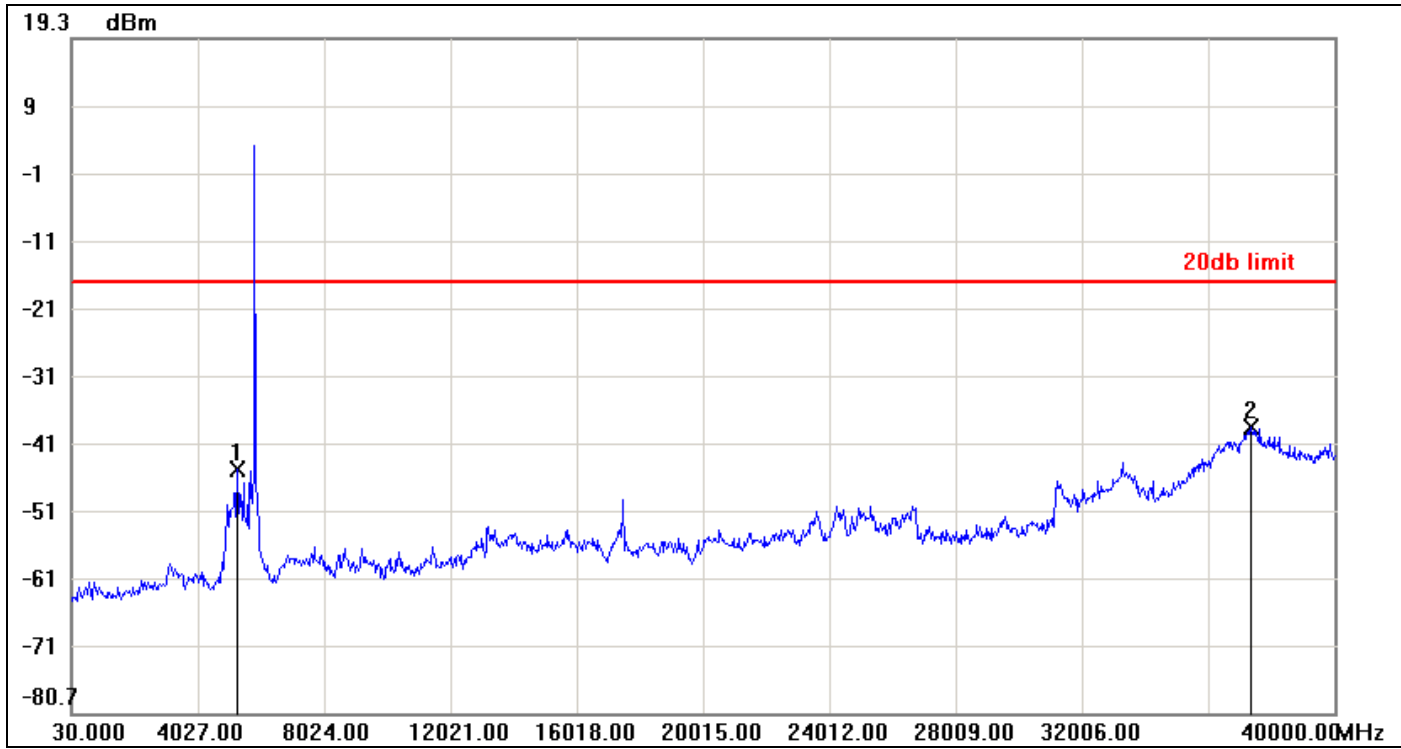

No.	Frequency(MHz)	Result(dBm)	Limit(dBm)	Margin(dBm)
1	5266.0700	-44.61	-16.89	-27.72
2	37361.9800	-38.36	-16.89	-21.47



IEEE 802.11n HT 40 mode / Chain 0

CH Low

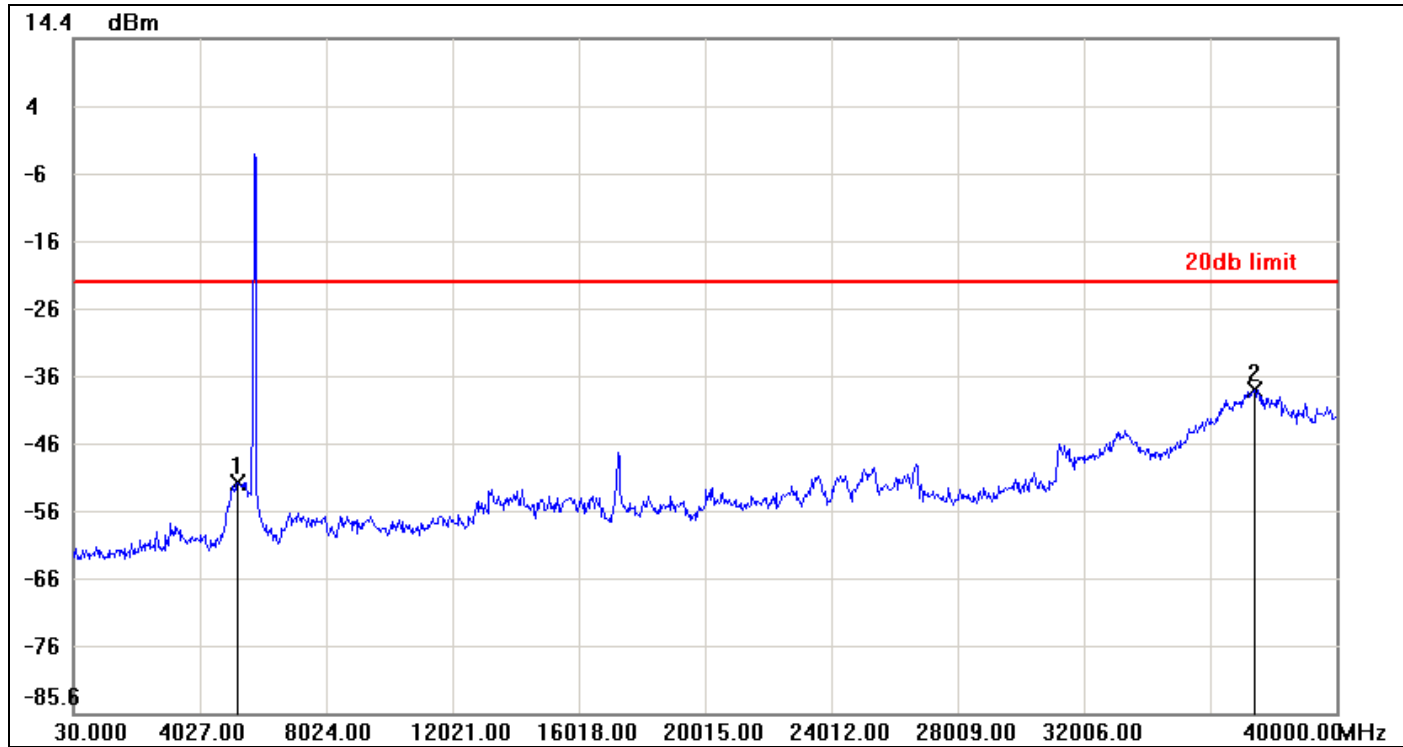

No.	Frequency(MHz)	Result(dBm)	Limit(dBm)	Margin(dBm)
1	5226.1000	-51.40	-21.78	-29.62
2	37401.9500	-37.82	-21.78	-16.04



CH High

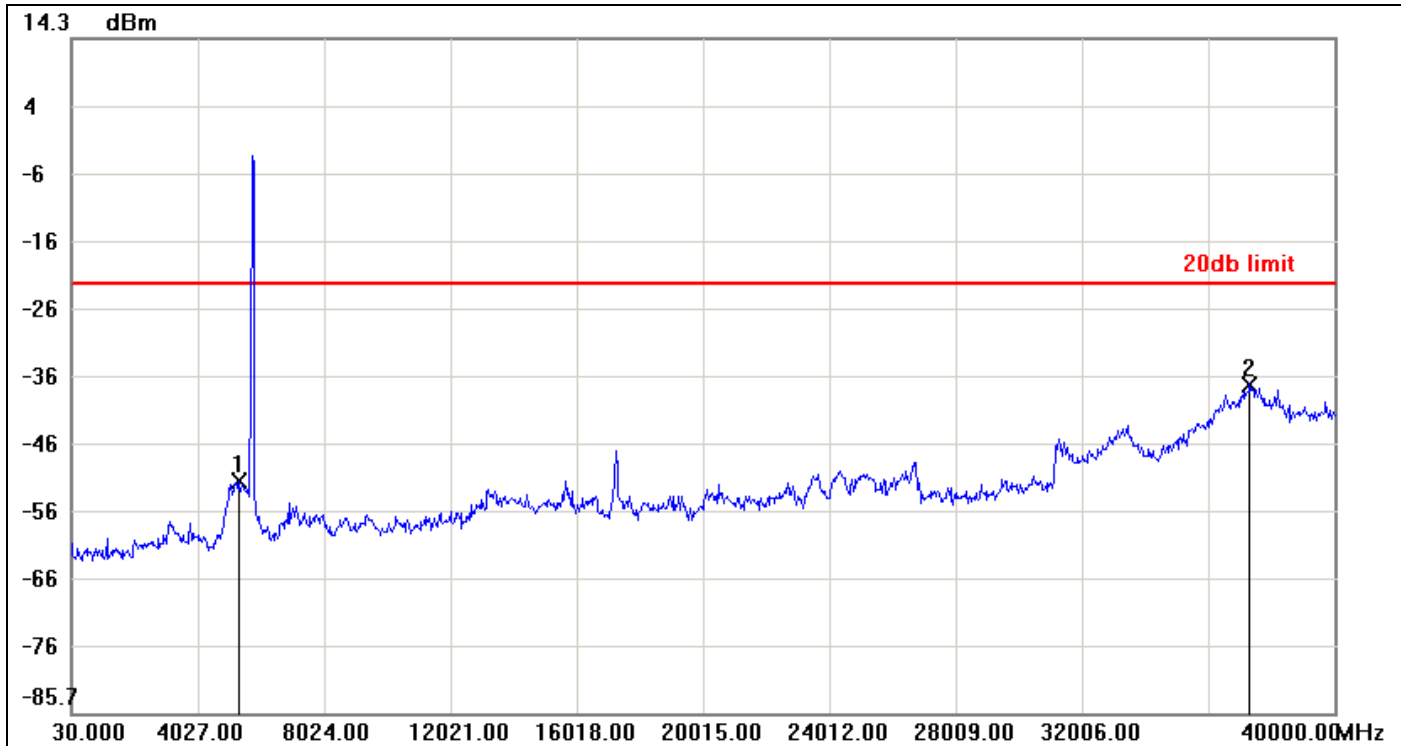

No.	Frequency(MHz)	Result(dBm)	Limit(dBm)	Margin(dBm)
1	5346.0400	-51.42	-22.13	-29.29
2	37322.0100	-36.97	-22.13	-14.84



IEEE 802.11n HT 40 mode / Chain 1

CH Low

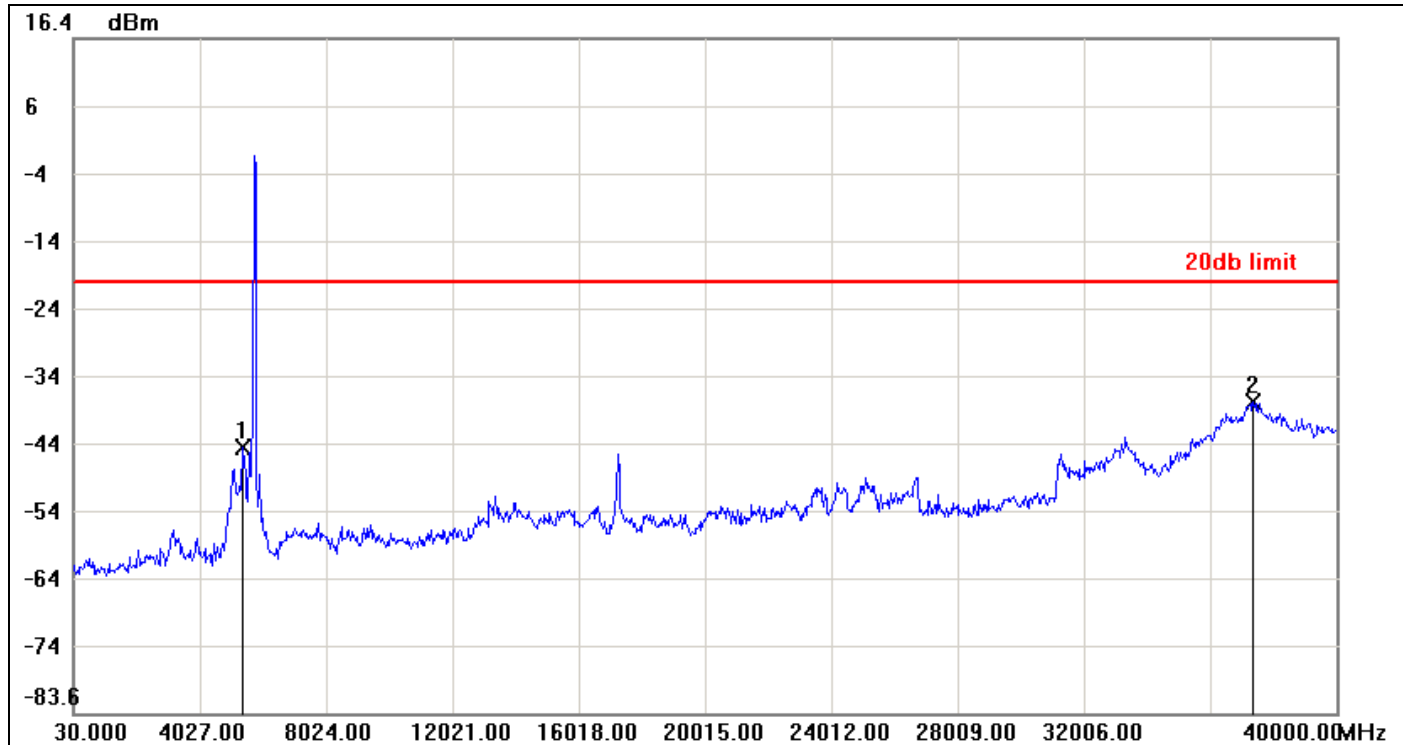

No.	Frequency(MHz)	Result(dBm)	Limit(dBm)	Margin(dBm)
1	5385.9800	-44.28	-19.68	-24.60
2	37361.9800	-37.53	-19.68	-17.85



CH High

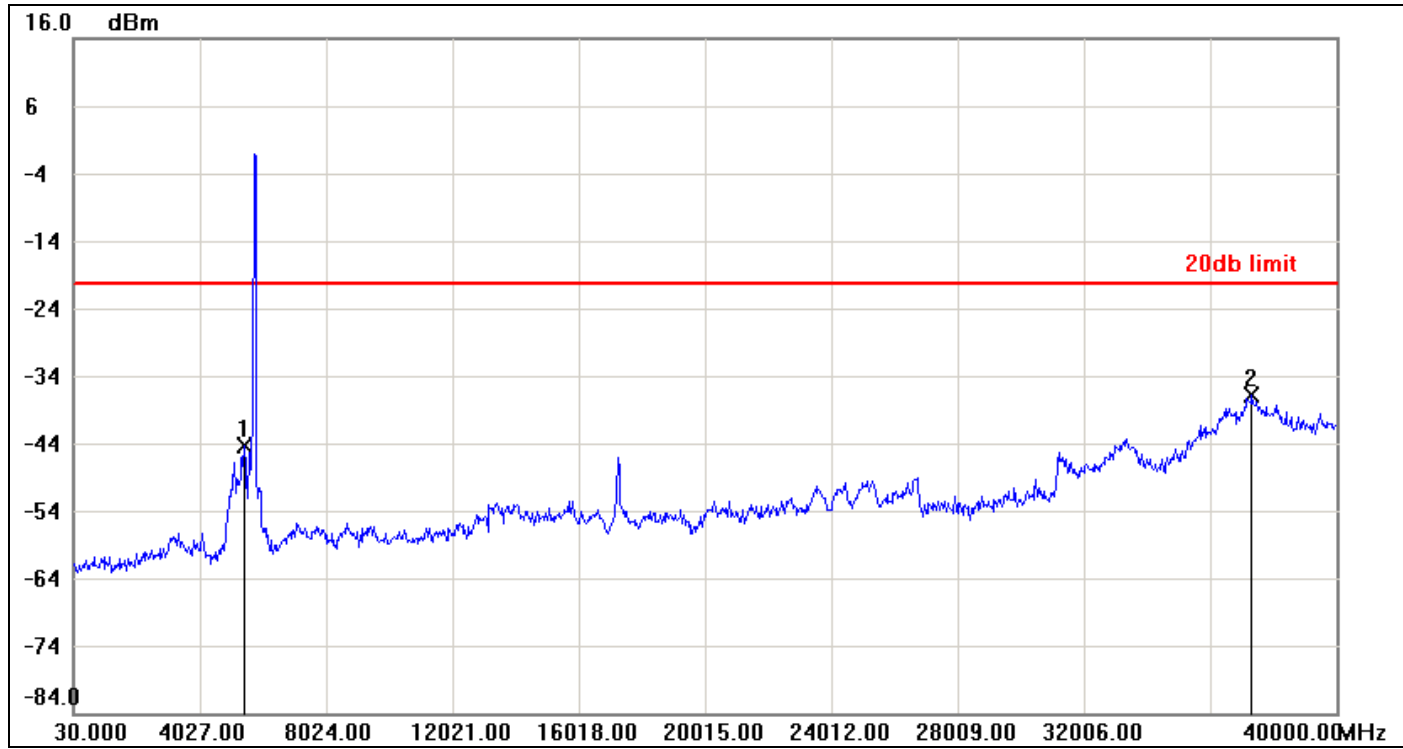

No.	Frequency(MHz)	Result(dBm)	Limit(dBm)	Margin(dBm)
1	5445.9500	-44.26	-20.24	-24.02
2	37322.0100	-36.87	-20.24	-16.63



7.4.2 Radiated Emissions

LIMIT

1. According to §15.209(a), except as provided elsewhere in this Subpart, the emissions from an intentional radiator shall not exceed the field strength levels specified in the following table:

Frequency (MHz)	Field Strength (µV/m)	Measurement Distance (m)
0.009 - 0.490	2400/F(kHz)	300
0.490 - 1.705	24000/F(kHz)	30
1.705 – 30.0	30	30
30-88	100	3
88-216	150	3
216-960	200	3
Above 960	500	3

Remark: Except as provided in paragraph (g), fundamental emissions from intentional radiators operating under this Section shall not be located in the frequency bands 54-72 MHz, 76-88 MHz, 174-216 MHz or 470-806 MHz. However, operation within these frequency bands is permitted under other sections of this Part, e.g., Sections 15.231 and 15.241.

2. In the above emission table, the tighter limit applies at the band edges.

Frequency (MHz)	Field Strength (µV/m at 3-meter)	Field Strength (dBµV/m at 3-meter)
0.009 - 0.490	2400/F(kHz) +80	20LOG((2400/F(kHz))+80)
0.490 - 1.705	24000/F(kHz) +40	20LOG((24000/F(kHz))+40)
1.705 – 30.0	30	69.54
30-88	100	40
88-216	150	43.5
216-960	200	46
Above 960	500	54



Test Configuration

9kHz ~ 30MHz

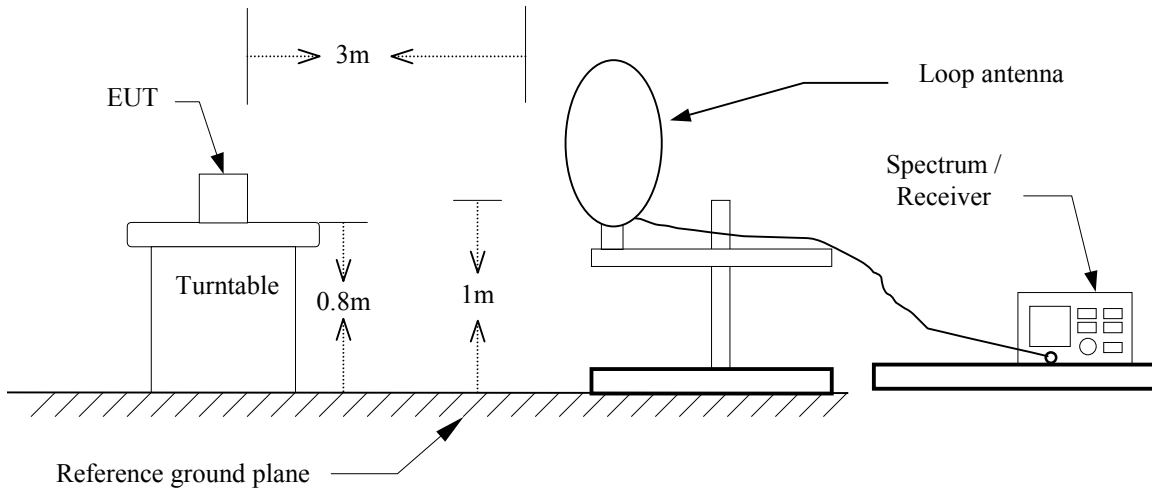

30MHz ~ 1 GHz

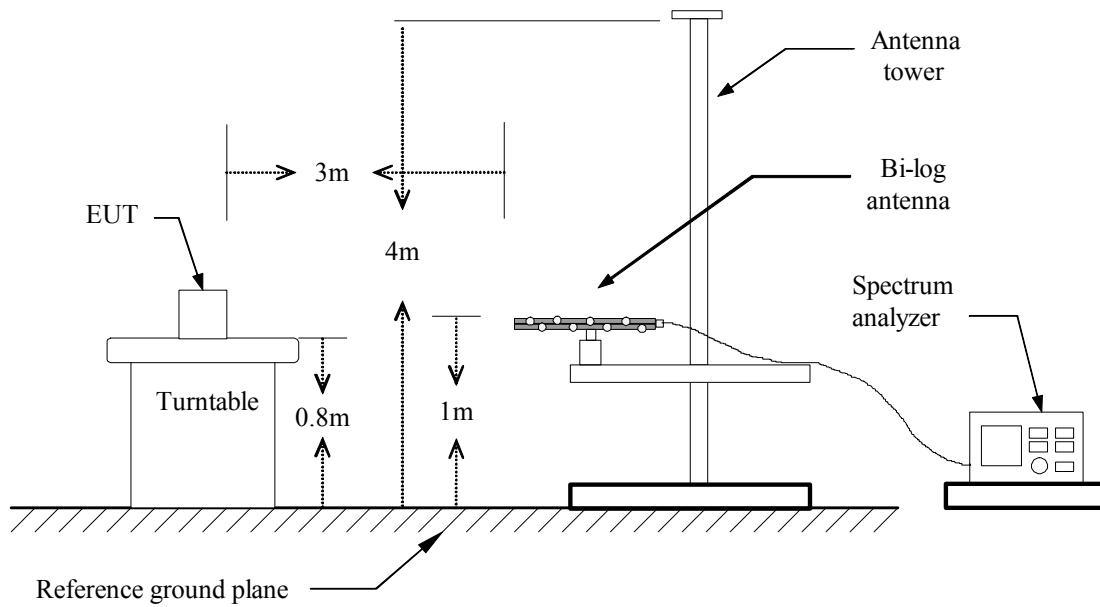



Above 1 GHz

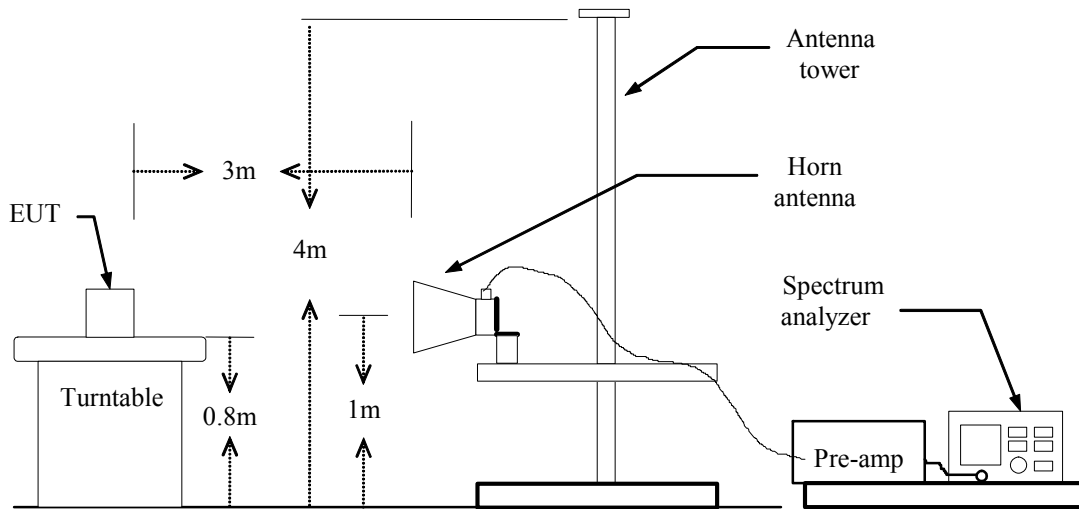



TEST PROCEDURE

1. The EUT is placed on a turntable, which is 0.8m above ground plane.
2. The turntable shall be rotated for 360 degrees to determine the position of maximum emission level.
3. EUT is set 3m away from the receiving antenna, which is varied from 1m to 4m to find out the highest emissions.
4. Maximum procedure was performed on the six highest emissions to ensure EUT compliance.
5. And also, each emission was to be maximized by changing the polarization of receiving antenna both horizontal and vertical.
6. Set the spectrum analyzer in the following setting as:
Below 1GHz:
RBW=100kHz / VBW=300kHz / Sweep=AUTO
Above 1GHz:
(a) PEAK: RBW=VBW=1MHz / Sweep=AUTO
(b) AVERAGE: RBW=1MHz / VBW=300Hz / Sweep=AUTO
7. Repeat above procedures until the measurements for all frequencies are complete.

**For OW-200N2-X****Below 1 GHz**

Operation Mode: Normal Link **Test Date:** October 3, 2013
Temperature: 27°C **Tested by:** Rex Huang
Humidity: 53% RH **Polarity:** Ver. / Hor.

Frequency (MHz)	Reading (dBuV)	Correction Factor (dB/m)	Result (dBuV/m)	Limit (dBuV/m)	Margin (dB)	Remark	Ant.Pol. (H/V)
30.0000	56.29	-20.45	35.84	40.00	-4.16	Peak	V
47.7833	66.86	-32.59	34.27	40.00	-5.73	Peak	V
151.2500	67.49	-28.98	38.51	43.50	-4.99	Peak	V
272.5000	60.89	-28.16	32.73	46.00	-13.27	Peak	V
374.3500	65.92	-26.06	39.86	46.00	-6.14	Peak	V
702.5333	55.60	-20.35	35.25	46.00	-10.75	Peak	V
151.2500	69.52	-28.98	40.54	43.50	-2.96	Peak	H
374.3500	70.95	-26.06	44.89	46.00	-1.11	Peak	H
675.0500	62.18	-20.54	41.64	46.00	-4.36	Peak	H
705.7667	61.13	-20.29	40.84	46.00	-5.16	Peak	H
749.4167	60.77	-19.53	41.24	46.00	-4.76	Peak	H
893.3000	58.53	-17.45	41.08	46.00	-4.92	Peak	H

Remark:

1. Measuring frequencies from 30 MHz to the 1GHz.
2. Radiated emissions measured in frequency range from 30 MHz to 1000MHz were made with an instrument using peak/quasi-peak detector mode.
3. Quasi-peak test would be performed if the peak result were greater than the quasi-peak limit or as required by the applicant.
4. Data of measurement within this frequency range shown " --- " in the table above means the reading of emissions are attenuated more than 20dB below the permissible limits or the field strength is too small to be measured.
5. Measurements above show only up to 6 maximum emissions noted, or would be lesser, with " N/A " remark, if no specific emissions from the EUT are recorded (ie: margin>20dB from the applicable limit) and considered that's already beyond the background noise floor.
6. Margin (dB) = Remark result (dBuV/m) – Quasi-peak limit (dBuV/m).



Above 1 GHz

Operation Mode: Tx / IEEE 802.11a mode/ CH Low

Test Date: October 3, 2013

Temperature: 27°C

Tested by: Rex Huang

Humidity: 53% RH

Polarity: Ver. / Hor.

Frequency (MHz)	Reading (dBuV)	Correction (dB/m)	Result (dBuV/m)	Limit (dBuV/m)	Margin (dB)	Remark	Ant.Pol. (H/V)
2598.333	51.01	0.94	51.95	74.00	-22.05	peak	V
N/A							
2505.000	51.18	0.69	51.87	74.00	-22.13	peak	H
N/A							

Remark:

1. Measuring frequencies from 1 GHz to the 10th harmonic of highest fundamental frequency.
2. Radiated emissions measured in frequency above 1000MHz were made with an instrument using peak/average detector mode.
3. Average test would be performed if the peak result were greater than the average limit or as required by the applicant.
4. Data of measurement within this frequency range shown “ --- ” in the table above means the reading of emissions are attenuated more than 20dB below the permissible limits or the field strength is too small to be measured.
5. Measurements above show only up to 6 maximum emissions noted, or would be lesser, with “ N/A ” remark, if no specific emissions from the EUT are recorded (ie: margin>20dB from the applicable limit) and considered that's already beyond the background noise floor.
6. Margin (dB) = Remark result (dBuV/m) – Average limit (dBuV/m).



Operation Mode: Tx / IEEE 802.11a mode/ CH Mid

Test Date: October 3, 2013

Temperature: 27°C

Tested by: Rex Huang

Humidity: 53% RH

Polarity: Ver. / Hor.

Frequency (MHz)	Reading (dBuV)	Correction (dB/m)	Result (dBuV/m)	Limit (dBuV/m)	Margin (dB)	Remark	Ant.Pol. (H/V)
2773.333	50.43	1.41	51.84	74.00	-22.16	peak	V
N/A							
2691.667	50.76	1.19	51.95	74.00	-22.05	peak	H
N/A							

Remark:

1. Measuring frequencies from 1 GHz to the 10th harmonic of highest fundamental frequency.
2. Radiated emissions measured in frequency above 1000MHz were made with an instrument using peak/average detector mode.
3. Average test would be performed if the peak result were greater than the average limit or as required by the applicant.
4. Data of measurement within this frequency range shown “ --- ” in the table above means the reading of emissions are attenuated more than 20dB below the permissible limits or the field strength is too small to be measured.
5. Measurements above show only up to 6 maximum emissions noted, or would be lesser, with “ N/A ” remark, if no specific emissions from the EUT are recorded (ie: margin>20dB from the applicable limit) and considered that's already beyond the background noise floor.
6. Margin (dB) = Remark result (dBuV/m) – Average limit (dBuV/m).



Operation Mode: Tx / IEEE 802.11a mode/ CH High

Test Date: October 3, 2013

Temperature: 27°C

Tested by: Rex Huang

Humidity: 53% RH

Polarity: Ver. / Hor.

Frequency (MHz)	Reading (dBuV)	Correction (dB/m)	Result (dBuV/m)	Limit (dBuV/m)	Margin (dB)	Remark	Ant.Pol. (H/V)
2470.000	51.08	0.46	51.54	74.00	-22.46	peak	V
N/A							
2528.333	50.86	0.76	51.62	74.00	-22.38	peak	H
N/A							

Remark:

1. Measuring frequencies from 1 GHz to the 10th harmonic of highest fundamental frequency.
2. Radiated emissions measured in frequency above 1000MHz were made with an instrument using peak/average detector mode.
3. Average test would be performed if the peak result were greater than the average limit or as required by the applicant.
4. Data of measurement within this frequency range shown “ --- ” in the table above means the reading of emissions are attenuated more than 20dB below the permissible limits or the field strength is too small to be measured.
5. Measurements above show only up to 6 maximum emissions noted, or would be lesser, with “ N/A ” remark, if no specific emissions from the EUT are recorded (ie: margin>20dB from the applicable limit) and considered that's already beyond the background noise floor.
6. Margin (dB) = Remark result (dBuV/m) – Average limit (dBuV/m).



Operation Mode: TX / IEEE 802.11n HT 20 mode / CH Low

Test Date: October 3, 2013

Temperature: 27°C

Tested by: Rex Huang

Humidity: 53% RH

Polarity: Ver. / Hor.

Frequency (MHz)	Reading (dBuV)	Correction (dB/m)	Result (dBuV/m)	Limit (dBuV/m)	Margin (dB)	Remark	Ant.Pol. (H/V)
2446.667	50.97	0.29	51.26	74.00	-22.74	peak	V
N/A							
2668.333	50.67	1.13	51.80	74.00	-22.20	peak	H
17233.333	45.96	21.96	67.92	74.00	-6.08	peak	H
17233.333	31.26	21.96	53.22	54.00	-0.78	AVG	H
N/A							

Remark:

1. Measuring frequencies from 1 GHz to the 10th harmonic of highest fundamental frequency.
2. Radiated emissions measured in frequency above 1000MHz were made with an instrument using peak/average detector mode.
3. Average test would be performed if the peak result were greater than the average limit or as required by the applicant.
4. Data of measurement within this frequency range shown “ --- ” in the table above means the reading of emissions are attenuated more than 20dB below the permissible limits or the field strength is too small to be measured.
5. Measurements above show only up to 6 maximum emissions noted, or would be lesser, with “ N/A ” remark, if no specific emissions from the EUT are recorded (ie: margin>20dB from the applicable limit) and considered that's already beyond the background noise floor.
6. Margin (dB) = Remark result (dBuV/m) – Average limit (dBuV/m).



Operation Mode: TX / IEEE 802.11n HT 20 mode / CH Mid

Test Date: October 3, 2013

Temperature: 27°C

Tested by: Rex Huang

Humidity: 53% RH

Polarity: Ver. / Hor.

Frequency (MHz)	Reading (dBuV)	Correction (dB/m)	Result (dBuV/m)	Limit (dBuV/m)	Margin (dB)	Remark	Ant.Pol. (H/V)
2516.667	50.97	0.72	51.69	74.00	-22.31	peak	V
N/A							
2551.667	51.16	0.82	51.98	74.00	-22.02	peak	H
17350.000	42.75	21.85	64.60	74.00	-9.40	peak	H
17350.000	31.88	21.85	53.73	54.00	-0.27	AVG	H
N/A							

Remark:

1. Measuring frequencies from 1 GHz to the 10th harmonic of highest fundamental frequency.
2. Radiated emissions measured in frequency above 1000MHz were made with an instrument using peak/average detector mode.
3. Average test would be performed if the peak result were greater than the average limit or as required by the applicant.
4. Data of measurement within this frequency range shown " --- " in the table above means the reading of emissions are attenuated more than 20dB below the permissible limits or the field strength is too small to be measured.
5. Measurements above show only up to 6 maximum emissions noted, or would be lesser, with " N/A " remark, if no specific emissions from the EUT are recorded (ie: margin > 20dB from the applicable limit) and considered that's already beyond the background noise floor.
6. Margin (dB) = Remark result (dBuV/m) – Average limit (dBuV/m).



Operation Mode: TX / IEEE 802.11n HT 20 mode / CH High Test Date: October 3, 2013

Temperature: 27°C Tested by: Rex Huang

Humidity: 53% RH Polarity: Ver. / Hor.

Frequency (MHz)	Reading (dBuV)	Correction (dB/m)	Result (dBuV/m)	Limit (dBuV/m)	Margin (dB)	Remark	Ant.Pol. (H/V)
2656.667	50.49	1.10	51.59	74.00	-22.41	peak	V
N/A							
2505.000	50.88	0.69	51.57	74.00	-22.43	peak	H
17466.667	45.60	21.74	67.34	74.00	-6.66	peak	H
17466.667	31.67	21.74	53.41	54.00	-0.59	AVG	H
N/A							

Remark:

1. Measuring frequencies from 1 GHz to the 10th harmonic of highest fundamental frequency.
2. Radiated emissions measured in frequency above 1000MHz were made with an instrument using peak/average detector mode.
3. Average test would be performed if the peak result were greater than the average limit or as required by the applicant.
4. Data of measurement within this frequency range shown “ --- ” in the table above means the reading of emissions are attenuated more than 20dB below the permissible limits or the field strength is too small to be measured.
5. Measurements above show only up to 6 maximum emissions noted, or would be lesser, with “ N/A ” remark, if no specific emissions from the EUT are recorded (ie: margin>20dB from the applicable limit) and considered that's already beyond the background noise floor.
6. Margin (dB) = Remark result (dBuV/m) – Average limit (dBuV/m).



Operation Mode: TX / IEEE 802.11n HT 40 mode / CH Low

Test Date: October 3, 2013

Temperature: 27°C

Tested by: Rex Huang

Humidity: 53% RH

Polarity: Ver. / Hor.

Frequency (MHz)	Reading (dBuV)	Correction (dB/m)	Result (dBuV/m)	Limit (dBuV/m)	Margin (dB)	Remark	Ant.Pol. (H/V)
2551.667	50.96	0.82	51.78	74.00	-22.22	peak	V
N/A							
2528.333	50.99	0.76	51.75	74.00	-22.25	peak	H
N/A							

Remark:

1. Measuring frequencies from 1 GHz to the 10th harmonic of highest fundamental frequency.
2. Radiated emissions measured in frequency above 1000MHz were made with an instrument using peak/average detector mode.
3. Average test would be performed if the peak result were greater than the average limit or as required by the applicant.
4. Data of measurement within this frequency range shown “ --- ” in the table above means the reading of emissions are attenuated more than 20dB below the permissible limits or the field strength is too small to be measured.
5. Measurements above show only up to 6 maximum emissions noted, or would be lesser, with “ N/A ” remark, if no specific emissions from the EUT are recorded (ie: margin > 20dB from the applicable limit) and considered that's already beyond the background noise floor.
6. Margin (dB) = Remark result (dBuV/m) – Average limit (dBuV/m).



Operation Mode: TX / IEEE 802.11n HT 40 mode / CH High Test Date: October 3, 2013

Temperature: 27°C Tested by: Rex Huang

Humidity: 53% RH Polarity: Ver. / Hor.

Frequency (MHz)	Reading (dBuV)	Correction (dB/m)	Result (dBuV/m)	Limit (dBuV/m)	Margin (dB)	Remark	Ant.Pol. (H/V)
2458.333	51.20	0.38	51.58	74.00	-22.42	peak	V
N/A							
2318.333	51.77	-0.17	51.60	74.00	-22.40	peak	H
17383.333	42.30	21.82	64.12	74.00	-9.88	peak	H
17383.333	31.13	21.82	52.95	54.00	-1.05	AVG	H
N/A							

Remark:

1. Measuring frequencies from 1 GHz to the 10th harmonic of highest fundamental frequency.
2. Radiated emissions measured in frequency above 1000MHz were made with an instrument using peak/average detector mode.
3. Average test would be performed if the peak result were greater than the average limit or as required by the applicant.
4. Data of measurement within this frequency range shown " --- " in the table above means the reading of emissions are attenuated more than 20dB below the permissible limits or the field strength is too small to be measured.
5. Measurements above show only up to 6 maximum emissions noted, or would be lesser, with " N/A " remark, if no specific emissions from the EUT are recorded (ie: margin > 20dB from the applicable limit) and considered that's already beyond the background noise floor.
6. Margin (dB) = Remark result (dBuV/m) – Average limit (dBuV/m).

**For OW-215N2-X****Below 1 GHz**

Operation Mode: Normal Link **Test Date:** October 3, 2013
Temperature: 27°C **Tested by:** Rex Huang
Humidity: 53% RH **Polarity:** Ver. / Hor.

Frequency (MHz)	Reading (dBuV)	Correction Factor (dB/m)	Result (dBuV/m)	Limit (dBuV/m)	Margin (dB)	Remark	Ant.Pol. (H/V)
30.0000	57.38	-20.45	36.93	40.00	-3.07	Peak	V
44.5500	66.03	-30.90	35.13	40.00	-4.87	Peak	V
89.8167	70.55	-34.16	36.39	43.50	-7.11	Peak	V
151.2500	69.42	-28.98	40.44	43.50	-3.06	Peak	V
374.3500	68.79	-26.06	42.73	46.00	-3.27	Peak	V
675.0500	57.71	-20.54	37.17	46.00	-8.83	Peak	V
151.2500	69.39	-28.98	40.41	43.50	-3.09	peak	H
299.9833	67.42	-27.73	39.69	46.00	-6.31	peak	H
374.3500	71.39	-26.06	45.33	46.00	-0.67	QP	H
675.0500	62.22	-20.54	41.68	46.00	-4.32	peak	H
705.7667	62.36	-20.29	42.07	46.00	-3.93	peak	H
749.4167	62.14	-19.53	42.61	46.00	-3.39	peak	H

Remark:

1. Measuring frequencies from 30 MHz to the 1GHz.
2. Radiated emissions measured in frequency range from 30 MHz to 1000MHz were made with an instrument using peak/quasi-peak detector mode.
3. Quasi-peak test would be performed if the peak result were greater than the quasi-peak limit or as required by the applicant.
4. Data of measurement within this frequency range shown “ --- ” in the table above means the reading of emissions are attenuated more than 20dB below the permissible limits or the field strength is too small to be measured.
5. Measurements above show only up to 6 maximum emissions noted, or would be lesser, with “ N/A ” remark, if no specific emissions from the EUT are recorded (ie: margin>20dB from the applicable limit) and considered that's already beyond the background noise floor.
6. Margin (dB) = Remark result (dBuV/m) – Quasi-peak limit (dBuV/m).



Above 1 GHz

Operation Mode: Tx / IEEE 802.11a mode/ CH Low

Test Date: October 3, 2013

Temperature: 27°C

Tested by: Rex Huang

Humidity: 53% RH

Polarity: Ver. / Hor.

Frequency (MHz)	Reading (dBuV)	Correction (dB/m)	Result (dBuV/m)	Limit (dBuV/m)	Margin (dB)	Remark	Ant.Pol. (H/V)
2330.000	51.98	-0.15	51.83	74.00	-22.17	peak	V
17233.333	41.80	21.96	63.76	74.00	-10.24	peak	V
17233.333	31.80	21.96	53.76	54.00	-0.24	AVG	V
N/A							
2645.000	50.91	1.07	51.98	74.00	-22.02	peak	H
17233.333	44.45	21.96	66.41	74.00	-7.59	peak	H
17233.333	31.30	21.96	53.26	54.00	-0.74	AVG	H
N/A							

Remark:

1. Measuring frequencies from 1 GHz to the 10th harmonic of highest fundamental frequency.
2. Radiated emissions measured in frequency above 1000MHz were made with an instrument using peak/average detector mode.
3. Average test would be performed if the peak result were greater than the average limit or as required by the applicant.
4. Data of measurement within this frequency range shown " --- " in the table above means the reading of emissions are attenuated more than 20dB below the permissible limits or the field strength is too small to be measured.
5. Measurements above show only up to 6 maximum emissions noted, or would be lesser, with " N/A " remark, if no specific emissions from the EUT are recorded (ie: margin>20dB from the applicable limit) and considered that's already beyond the background noise floor.
6. Margin (dB) = Remark result (dBuV/m) – Average limit (dBuV/m).



Operation Mode: Tx / IEEE 802.11a mode/ CH Mid

Test Date: October 3, 2013

Temperature: 27°C

Tested by: Rex Huang

Humidity: 53% RH

Polarity: Ver. / Hor.

Frequency (MHz)	Reading (dBuV)	Correction (dB/m)	Result (dBuV/m)	Limit (dBuV/m)	Margin (dB)	Remark	Ant.Pol. (H/V)
2540.000	50.95	0.79	51.74	74.00	-22.26	peak	V
17366.667	40.62	21.83	62.45	74.00	-11.55	peak	V
17366.667	30.50	21.83	52.33	54.00	-1.67	AVG	V
N/A							
2446.667	51.61	0.29	51.90	74.00	-22.10	peak	H
17350.000	41.18	21.85	63.03	74.00	-10.97	peak	H
17350.000	31.00	21.85	52.85	54.00	-1.15	AVG	H
N/A							

Remark:

1. Measuring frequencies from 1 GHz to the 10th harmonic of highest fundamental frequency.
2. Radiated emissions measured in frequency above 1000MHz were made with an instrument using peak/average detector mode.
3. Average test would be performed if the peak result were greater than the average limit or as required by the applicant.
4. Data of measurement within this frequency range shown “ --- ” in the table above means the reading of emissions are attenuated more than 20dB below the permissible limits or the field strength is too small to be measured.
5. Measurements above show only up to 6 maximum emissions noted, or would be lesser, with “ N/A ” remark, if no specific emissions from the EUT are recorded (ie: margin>20dB from the applicable limit) and considered that's already beyond the background noise floor.
6. Margin (dB) = Remark result (dBuV/m) – Average limit (dBuV/m).



Operation Mode: Tx / IEEE 802.11a mode/ CH High

Test Date: October 3, 2013

Temperature: 27°C

Tested by: Rex Huang

Humidity: 53% RH

Polarity: Ver. / Hor.

Frequency (MHz)	Reading (dBuV)	Correction (dB/m)	Result (dBuV/m)	Limit (dBuV/m)	Margin (dB)	Remark	Ant.Pol. (H/V)
2540.000	50.46	0.79	51.25	74.00	-22.75	peak	V
N/A							
2563.333	51.05	0.85	51.90	74.00	-22.10	peak	H
17466.667	40.06	21.74	61.80	74.00	-12.20	peak	H
17466.667	30.74	21.74	52.48	54.00	-1.52	AVG	H
N/A							

Remark:

1. Measuring frequencies from 1 GHz to the 10th harmonic of highest fundamental frequency.
2. Radiated emissions measured in frequency above 1000MHz were made with an instrument using peak/average detector mode.
3. Average test would be performed if the peak result were greater than the average limit or as required by the applicant.
4. Data of measurement within this frequency range shown “ --- ” in the table above means the reading of emissions are attenuated more than 20dB below the permissible limits or the field strength is too small to be measured.
5. Measurements above show only up to 6 maximum emissions noted, or would be lesser, with “ N/A ” remark, if no specific emissions from the EUT are recorded (ie: margin>20dB from the applicable limit) and considered that's already beyond the background noise floor.
6. Margin (dB) = Remark result (dBuV/m) – Average limit (dBuV/m).



Operation Mode: TX / IEEE 802.11n HT 20 mode / CH Low

Test Date: October 3, 2013

Temperature: 27°C

Tested by: Rex Huang

Humidity: 53% RH

Polarity: Ver. / Hor.

Frequency (MHz)	Reading (dBuV)	Correction (dB/m)	Result (dBuV/m)	Limit (dBuV/m)	Margin (dB)	Remark	Ant.Pol. (H/V)
2796.667	50.50	1.47	51.97	74.00	-22.03	peak	V
N/A							
2773.333	50.54	1.41	51.95	74.00	-22.05	peak	H
N/A							

Remark:

1. Measuring frequencies from 1 GHz to the 10th harmonic of highest fundamental frequency.
2. Radiated emissions measured in frequency above 1000MHz were made with an instrument using peak/average detector mode.
3. Average test would be performed if the peak result were greater than the average limit or as required by the applicant.
4. Data of measurement within this frequency range shown “ --- ” in the table above means the reading of emissions are attenuated more than 20dB below the permissible limits or the field strength is too small to be measured.
5. Measurements above show only up to 6 maximum emissions noted, or would be lesser, with “ N/A ” remark, if no specific emissions from the EUT are recorded (ie: margin>20dB from the applicable limit) and considered that's already beyond the background noise floor.
6. Margin (dB) = Remark result (dBuV/m) – Average limit (dBuV/m).



Operation Mode: TX / IEEE 802.11n HT 20 mode / CH Mid

Test Date: October 3, 2013

Temperature: 27°C

Tested by: Rex Huang

Humidity: 53% RH

Polarity: Ver. / Hor.

Frequency (MHz)	Reading (dBuV)	Correction (dB/m)	Result (dBuV/m)	Limit (dBuV/m)	Margin (dB)	Remark	Ant.Pol. (H/V)
2551.667	50.95	0.82	51.77	74.00	-22.23	peak	V
N/A							
2458.333	51.35	0.38	51.73	74.00	-22.27	peak	H
N/A							

Remark:

1. Measuring frequencies from 1 GHz to the 10th harmonic of highest fundamental frequency.
2. Radiated emissions measured in frequency above 1000MHz were made with an instrument using peak/average detector mode.
3. Average test would be performed if the peak result were greater than the average limit or as required by the applicant.
4. Data of measurement within this frequency range shown “ --- ” in the table above means the reading of emissions are attenuated more than 20dB below the permissible limits or the field strength is too small to be measured.
5. Measurements above show only up to 6 maximum emissions noted, or would be lesser, with “ N/A ” remark, if no specific emissions from the EUT are recorded (ie: margin>20dB from the applicable limit) and considered that's already beyond the background noise floor.
6. Margin (dB) = Remark result (dBuV/m) – Average limit (dBuV/m).



Operation Mode: TX / IEEE 802.11n HT 20 mode / CH High **Test Date:** October 3, 2013

Temperature: 27°C **Tested by:** Rex Huang

Humidity: 53% RH **Polarity:** Ver. / Hor.

Frequency (MHz)	Reading (dBuV)	Correction (dB/m)	Result (dBuV/m)	Limit (dBuV/m)	Margin (dB)	Remark	Ant.Pol. (H/V)
2668.333	50.69	1.13	51.82	74.00	-22.18	peak	V
N/A							
2773.333	50.11	1.41	51.52	74.00	-22.48	peak	H
N/A							

Remark:

1. Measuring frequencies from 1 GHz to the 10th harmonic of highest fundamental frequency.
2. Radiated emissions measured in frequency above 1000MHz were made with an instrument using peak/average detector mode.
3. Average test would be performed if the peak result were greater than the average limit or as required by the applicant.
4. Data of measurement within this frequency range shown “ --- ” in the table above means the reading of emissions are attenuated more than 20dB below the permissible limits or the field strength is too small to be measured.
5. Measurements above show only up to 6 maximum emissions noted, or would be lesser, with “ N/A ” remark, if no specific emissions from the EUT are recorded (ie: margin>20dB from the applicable limit) and considered that's already beyond the background noise floor.
6. Margin (dB) = Remark result (dBuV/m) – Average limit (dBuV/m).



Operation Mode: TX / IEEE 802.11n HT 40 mode / CH Low **Test Date:** October 3, 2013

Temperature: 27°C **Tested by:** Rex Huang

Humidity: 53% RH **Polarity:** Ver. / Hor.

Frequency (MHz)	Reading (dBuV)	Correction (dB/m)	Result (dBuV/m)	Limit (dBuV/m)	Margin (dB)	Remark	Ant.Pol. (H/V)
2575.000	50.74	0.88	51.62	74.00	-22.38	peak	V
N/A							
2645.000	50.67	1.07	51.74	74.00	-22.26	peak	H
N/A							

Remark:

1. Measuring frequencies from 1 GHz to the 10th harmonic of highest fundamental frequency.
2. Radiated emissions measured in frequency above 1000MHz were made with an instrument using peak/average detector mode.
3. Average test would be performed if the peak result were greater than the average limit or as required by the applicant.
4. Data of measurement within this frequency range shown “ --- ” in the table above means the reading of emissions are attenuated more than 20dB below the permissible limits or the field strength is too small to be measured.
5. Measurements above show only up to 6 maximum emissions noted, or would be lesser, with “ N/A ” remark, if no specific emissions from the EUT are recorded (ie: margin>20dB from the applicable limit) and considered that's already beyond the background noise floor.
6. Margin (dB) = Remark result (dBuV/m) – Average limit (dBuV/m).



Operation Mode: TX / IEEE 802.11n HT 40 mode / CH High **Test Date:** October 3, 2013

Temperature: 27°C **Tested by:** Rex Huang

Humidity: 53% RH **Polarity:** Ver. / Hor.

Frequency (MHz)	Reading (dBuV)	Correction (dB/m)	Result (dBuV/m)	Limit (dBuV/m)	Margin (dB)	Remark	Ant.Pol. (H/V)
2586.667	50.66	0.91	51.57	74.00	-22.43	peak	V
N/A							
2586.667	51.00	0.91	51.91	74.00	-22.09	peak	H
N/A							

Remark:

1. Measuring frequencies from 1 GHz to the 10th harmonic of highest fundamental frequency.
2. Radiated emissions measured in frequency above 1000MHz were made with an instrument using peak/average detector mode.
3. Average test would be performed if the peak result were greater than the average limit or as required by the applicant.
4. Data of measurement within this frequency range shown “ --- ” in the table above means the reading of emissions are attenuated more than 20dB below the permissible limits or the field strength is too small to be measured.
5. Measurements above show only up to 6 maximum emissions noted, or would be lesser, with “ N/A ” remark, if no specific emissions from the EUT are recorded (ie: margin>20dB from the applicable limit) and considered that's already beyond the background noise floor.
6. Margin (dB) = Remark result (dBuV/m) – Average limit (dBuV/m).



7.5 POWERLINE CONDUCTED EMISSIONS

LIMIT

According to §15.207(a), except as shown in paragraphs (b) and (c) of this section, for an intentional radiator that is designed to be connected to the public utility (AC) power line, the radio frequency voltage that is conducted back onto the AC power line on any frequency or frequencies within the band 150 kHz to 30 MHz shall not exceed the limits in the following table, as measured using a 50 μ H/50 ohms line impedance stabilization network (LISN). Compliance with the provisions of this paragraph shall be based on the measurement of the radio frequency voltage between each power line and ground at the power terminal. The lower limit applies at the boundary between the frequency ranges.

Frequency Range (MHz)	Limits (dB μ V)	
	Quasi-peak	Average
0.15 to 0.50	66 to 56*	56 to 46*
0.50 to 5	56	46
5 to 30	60	50

* Decreases with the logarithm of the frequency.

Test Configuration

See test photographs attached in Appendix 1 for the actual connections between EUT and support equipment.

TEST PROCEDURE

1. The EUT was placed on a table, which is 0.8m above ground plane.
2. Maximum procedure was performed on the six highest emissions to ensure EUT compliance.
3. Repeat above procedures until all frequency measured were complete.



TEST RESULTS

The initial step in collecting conducted data is a spectrum analyzer peak scan of the measurement range. Significant peaks are then marked as shown on the following data page, and these signals are then quasi-peaked.

Test Data

Operation Mode: Normal Link **Test Date:** December 11, 2013
Temperature: 24°C **Tested by:** Bibby Lin
Humidity: 50% RH

Freq. (MHz)	QP Reading (dBuV)	AV Reading (dBuV)	Corr. factor (dB)	QP Result (dBuV)	AV Result (dBuV)	QP Limit (dBuV)	AV Limit (dBuV)	QP Margin (dB)	AV Margin (dB)	Note
0.1536	38.57	18.27	9.58	48.15	27.85	65.80	55.80	-17.65	-27.95	L1
0.1590	41.40	24.62	9.58	50.98	34.20	65.51	55.52	-14.53	-21.32	L1
0.1957	35.69	18.73	9.58	45.27	28.31	63.79	53.79	-18.52	-25.48	L1
0.3833	29.68	22.80	9.58	39.26	32.38	58.21	48.21	-18.95	-15.83	L1
8.7160	32.12	29.37	9.66	41.78	39.03	60.00	50.00	-18.22	-10.97	L1
9.3898	30.88	29.54	9.66	40.54	39.20	60.00	50.00	-19.46	-10.80	L1
0.1638	40.28	23.03	9.66	49.94	32.69	65.26	55.27	-15.32	-22.58	L2
0.1703	37.71	16.11	9.66	47.37	25.77	64.94	54.95	-17.57	-29.18	L2
0.1954	35.64	18.57	9.67	45.31	28.24	63.80	53.80	-18.49	-25.56	L2
0.3854	30.86	24.17	9.67	40.53	33.84	58.16	48.16	-17.63	-14.32	L2
9.3896	31.15	29.55	9.89	41.04	39.44	60.00	50.00	-18.96	-10.56	L2
19.3879	20.17	14.49	10.00	30.17	24.49	60.00	50.00	-29.83	-25.51	L2

Remark:

1. Measuring frequencies from 0.15 MHz to 30MHz.
2. The emissions measured in frequency range from 0.15 MHz to 30MHz were made with an instrument using Quasi-peak detector and average detector.
3. The IF bandwidth of SPA between 0.15MHz to 30MHz was 10kHz; the IF bandwidth of Test Receiver between 0.15MHz to 30MHz was 9kHz.
4. L1 = Line One (Live Line) / L2 = Line Two (Neutral Line)



Test Plots

Conducted emissions (Line 1)

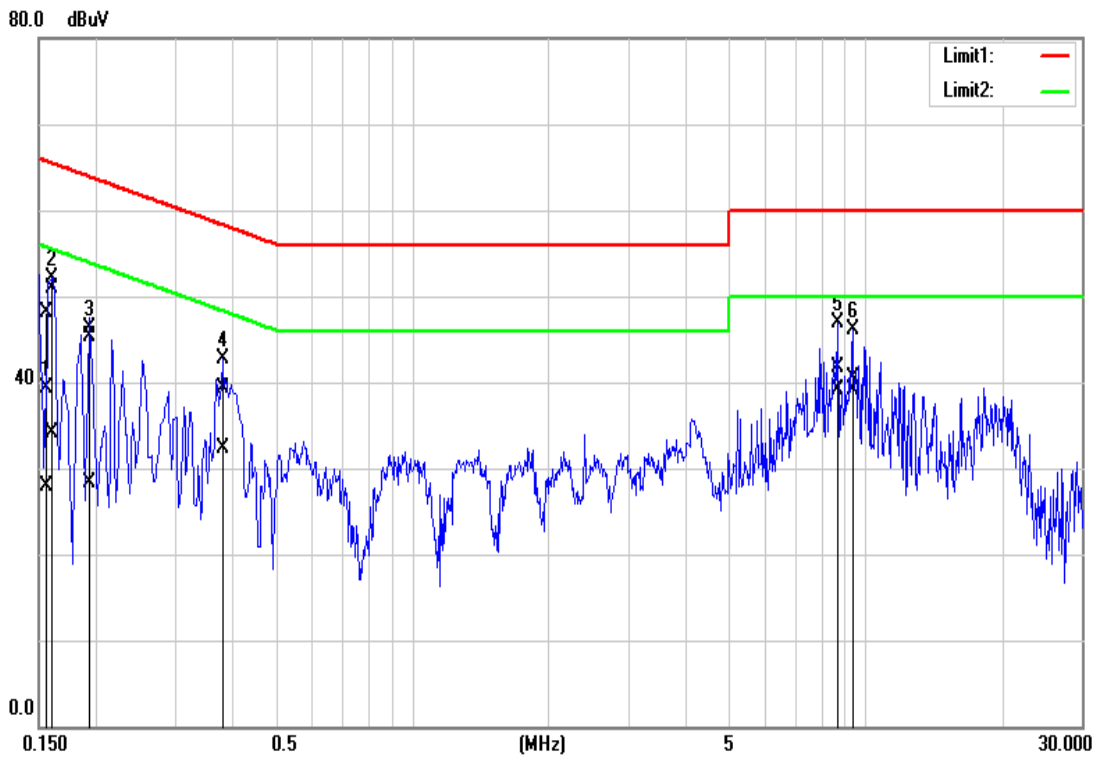

Conducted emissions (Line 2)

