

# Operational Description

Project: EXA21  
Filename: EXA21 operational description

Version: 1.0  
Date: 04.04.2019

Prepared by: Rauno Nikkilä  
Checked by:  
Accepted by: Mika Karttunen

Distribution:  
Change history:

| Version: | Date:    | Author: | Remarks:                |
|----------|----------|---------|-------------------------|
| 1.0      | 4.4.2019 | RN      | Operational Description |
|          |          |         |                         |
|          |          |         |                         |
|          |          |         |                         |
|          |          |         |                         |
|          |          |         |                         |

|  |   |
|--|---|
| 1. PRINCIPLES OF OPERATION .....             | 3 |
| EXA21 BLOCK DIAGRAM AND COMPONENTS .....     | 3 |
| 1.1.1. MICRO USB CONNECTOR.....              | 4 |
| 1.1.2. BLUETOOTH LOW ENERGY (BLE) RADIO..... | 4 |
| 1.1.3. RFID RADIO .....                      | 4 |
| 1.1.4. ANTENNAS.....                         | 4 |
| 1.1.5. BUTTON / LED .....                    | 4 |
| 1.1.6. DISPLAY .....                         | 4 |
| 1.1.7. AUDIO .....                           | 4 |
| 1.1.8. MAIN BATTERY .....                    | 5 |

## 1. PRINCIPLES OF OPERATION

The Nordic ID EXA21 is wearable terminal for data collection purpose. It is intended to be used as platform device for commercial devices for e.g. either mobile phone or tablet. EXA21 will offer BLE (Bluetooth low energy) technology for data communication between EXA21 and commercial device.

EXA21 does not have operating system but it has so called Nordic ID IOT platform which takes a care of RFID, BLE, imager and other operations. This means that all intelligence and software what is needed must be installed in commercial host device.

For this reason no global end user operational description or user's manual is possible. The hardware components and interactions that make up this product are following:

### EXA21 BLOCK DIAGRAM AND COMPONENTS

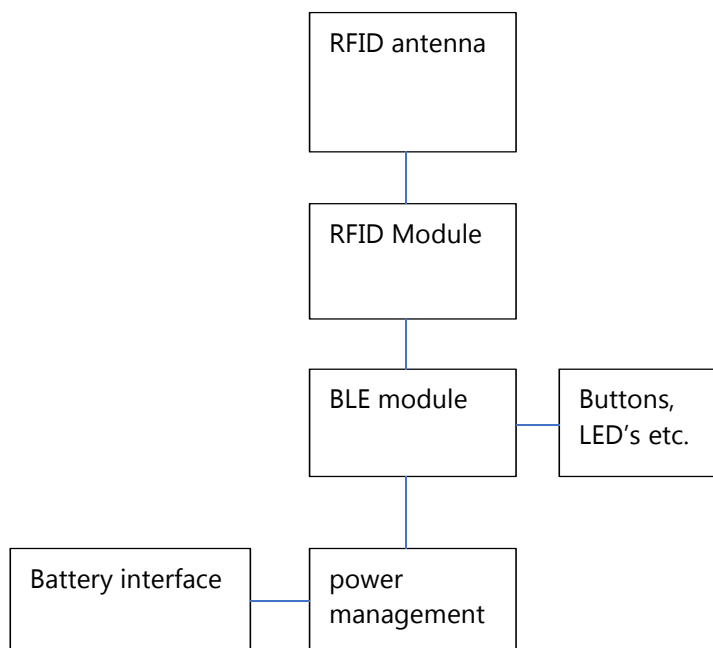

### 1.1.1. MICRO USB CONNECTOR

The micro USB connector provides USB charging and connect via USB functionality.

### 1.1.2. BLUETOOTH LOW ENERGY (BLE) RADIO

Device has FCC / IC certified Raytac BLE module MDBT50Q-P1M with integrated chip antenna. BLE is used for outside communication.

FCC ID: SH6MDBT50Q      IC ID: 8017A-MDBT50Q

### 1.1.3. RFID RADIO

The device has FCC / IC certified Nordic ID NUR-051 UHF RFID module. The RFID module reads and writes UHF RFID tags.

FCC ID: SCCNUR0W1      IC ID: 5137A-NUR0W1

### 1.1.4. ANTENNAS

#### UHF RFID

Specification:

|                 |               |
|-----------------|---------------|
| Frequency Range | 902 - 928 MHz |
| Peak Gain       | -4 dBi        |
| Impedance       | 50 $\Omega$   |

#### Bluetooth

Specification:

|                 |             |
|-----------------|-------------|
| Frequency Range | 2.4 GHz     |
| Peak Gain       | 0.41 dBi    |
| Impedance       | 50 $\Omega$ |

### 1.1.5. BUTTON / LED

Device has two buttons: for power off/on and RFID scan.

Device has one multicolor led for illustrative purposes of operation.

### 1.1.6. DISPLAY

The EXA21 does not have integrated display. Host device display can be used when needed. Host device can be connected to EXA21 via BLE.

### 1.1.7. AUDIO

Device has only a buzzer.

### 1.1.8. MAIN BATTERY

The main battery is user changeable 3.7VDC, 660mAh rechargeable Li-Polymer battery. It has an internal over charge / discharge and over current protection circuit.