



TEST REPORT

Report Number: 15126863-E5V2

Applicant : Sonos, Inc.
301 Coromar Dr
Goleta, CA 93117 USA

Model : S55

Brand : Sonos

FCC ID : SBVRM055

IC : 5373A-RM055

EUT Description : Wireless Smart Speaker

Test Standard(s) : FCC 47 CFR PART 15 SUBPART E
ISED RSS-247 ISSUE 3
ISED RSS-GEN ISSUE 5 + A1 + A2

Date Of Issue:
2024-06-13

Prepared by:
UL Verification Services Inc.
47173 Benicia Street
Fremont, CA 94538 U.S.A.
TEL: (510) 319-4000
FAX: (510) 661-0888



REPORT REVISION HISTORY

Rev.	Issue Date	Revisions	Revised By
V1	2024-05-30	Initial Issue	--
V2	2024-06-13	Section 6.5 & 9.3 Updated	Henry Lau

TABLE OF CONTENTS

REPORT REVISION HISTORY	2
TABLE OF CONTENTS	3
1. ATTESTATION OF TEST RESULTS	6
2. TEST RESULT SUMMARY	8
3. TEST METHODOLOGY	9
4. FACILITIES AND ACCREDITATION	9
5. DECISION RULES AND MEASUREMENT UNCERTAINTY	10
5.1. METROLOGICAL TRACEABILITY	10
5.2. DECISION RULES.....	10
5.3. MEASUREMENT UNCERTAINTY.....	10
6. EQUIPMENT UNDER TEST	12
6.1. EUT DESCRIPTION	12
6.2. MAXIMUM OUTPUT POWER.....	12
6.3. DESCRIPTION OF AVAILABLE ANTENNAS	14
6.4. SOFTWARE AND FIRMWARE.....	14
6.5. TEST REDUCTION CASE.....	14
6.6. WORST-CASE CONFIGURATION AND MODE.....	15
6.7. DESCRIPTION OF TEST SETUP.....	15
7. MEASUREMENT METHOD.....	18
8. TEST AND MEASUREMENT EQUIPMENT	19
9. ANTENNA PORT TEST RESULTS	20
9.1. ON TIME AND DUTY CYCLE.....	20
9.2. 26 dB BANDWIDTH.....	22
9.2.1. 802.11ax HE20 MODE 2TX IN THE 5.2GHz BAND.....	22
9.2.2. 802.11ax HE40 MODE 2TX IN THE 5.2GHz BAND.....	30
9.2.3. 802.11ax HE80 MODE 2TX IN THE 5.2GHz BAND.....	31
9.2.4. 802.11ax HE20 MODE 2TX IN THE 5.3GHz BAND.....	32
9.2.5. 802.11ax HE40 MODE 2TX IN THE 5.3GHz BAND.....	40
9.2.6. 802.11ax HE80 MODE 2TX IN THE 5.3GHz BAND.....	41
9.2.7. 802.11ax HE20 MODE 2TX IN THE 5.6GHz BAND.....	42
9.2.8. 802.11ax HE40 MODE 2TX IN THE 5.6GHz BAND.....	50
9.2.9. 802.11ax HE80 MODE 2TX IN THE 5.6GHz BAND.....	52
9.2.10. 802.11ax HE20 MODE 2TX IN THE 5.8GHz BAND.....	53
9.2.11. 802.11ax HE40 MODE 2TX IN THE 5.8GHz BAND.....	61

9.2.12. 802.11ax HE80 MODE 2TX IN THE 5.8GHz BAND.....62

9.3. 99% BANDWIDTH.....63

9.3.1. 802.11ax HE20 MODE 2TX IN THE 5.2GHz BAND.....63

9.3.2. 802.11ax HE40 MODE 2TX IN THE 5.2GHz BAND.....71

9.3.3. 802.11ax HE80 MODE 2TX IN THE 5.2GHz BAND.....72

9.3.4. 802.11ax HE20 MODE 2TX IN THE 5.3GHz BAND.....73

9.3.5. 802.11ax HE40 MODE 2TX IN THE 5.3GHz BAND.....81

9.3.6. 802.11ax HE80 MODE 2TX IN THE 5.3GHz BAND.....83

9.3.7. 802.11ax HE20 MODE 2TX IN THE 5.6GHz BAND.....84

9.3.8. 802.11ax HE40 MODE 2TX IN THE 5.6GHz BAND.....92

9.3.9. 802.11ax HE80 MODE 2TX IN THE 5.6GHz BAND.....94

9.3.10. 802.11ax HE20 MODE 2TX IN THE 5.8GHz BAND.....95

9.3.11. 802.11ax HE40 MODE 2TX IN THE 5.8GHz BAND.....103

9.3.12. 802.11ax HE80 MODE 2TX IN THE 5.8GHz BAND.....104

9.4. 6 dB BANDWIDTH.....105

9.4.1. 802.11ax HE20 MODE 2TX IN THE 5.8GHz BAND.....106

9.4.2. 802.11ax HE40 MODE 2TX IN THE 5.8GHz BAND.....114

9.4.3. 802.11ax HE80 MODE 2TX IN THE 5.8GHz BAND.....115

9.5. OUTPUT POWER AND PSD.....116

9.5.1. 802.11ax HE20 MODE 2TX IN THE 5.2GHz BAND (FCC+IC).....119

9.5.2. 802.11ax HE40 MODE 2TX IN THE 5.2GHz BAND (FCC+IC).....132

9.5.3. 802.11ax HE80 MODE 2TX IN THE 5.2GHz BAND (FCC+IC).....135

9.5.4. 802.11ax HE20 MODE 2TX IN THE 5.3GHz BAND (FCC+IC).....137

9.5.5. 802.11ax HE40 MODE 2TX IN THE 5.3GHz BAND (FCC+IC).....157

9.5.6. 802.11ax HE80 MODE 2TX IN THE 5.3GHz BAND (FCC+IC).....160

9.5.7. 802.11ax HE20 MODE 2TX IN THE 5.6GHz BAND (FCC+IC).....162

9.5.8. 802.11ax HE40 MODE 2TX IN THE 5.6GHz BAND (FCC+IC).....182

9.5.9. 802.11ax HE80 MODE 2TX IN THE 5.6GHz BAND (FCC+IC).....184

9.5.10. 802.11ax HE20 MODE 2TX IN THE 5.8GHz BAND (FCC+IC).....186

9.5.11. 802.11ax HE40 MODE 2TX IN THE 5.8GHz BAND (FCC+IC).....197

9.5.12. 802.11ax HE80 MODE 2TX IN THE 5.8GHz BAND (FCC+IC).....199

10. RADIATED TEST RESULTS.....200

10.1. TRANSMITTER ABOVE 1 GHz.....202

10.1.1. TX ABOVE 1 GHz 802.11ax HE20 MODE IN THE 5.2GHz BAND.....202

10.1.2. TX ABOVE 1 GHz 802.11ax HE40 MODE IN THE 5.2GHz BAND.....212

10.1.3. TX ABOVE 1 GHz 802.11ax HE80 MODE IN THE 5.2GHz BAND.....214

10.1.4. TX ABOVE 1 GHz 802.11ax HE20 MODE IN THE 5.3GHz BAND.....216

10.1.5. TX ABOVE 1 GHz 802.11ax HE40 MODE IN THE 5.3GHz BAND.....226

10.1.6. TX ABOVE 1 GHz 802.11ax HE80 MODE IN THE 5.3GHz BAND.....228

10.1.7. TX ABOVE 1 GHz 802.11ax HE20 MODE IN THE 5.6GHz BAND.....230

10.1.8. TX ABOVE 1 GHz 802.11ax HE40 MODE IN THE 5.6GHz BAND.....244

10.1.9. TX ABOVE 1 GHz 802.11ax HE80 MODE IN THE 5.6GHz BAND.....248

10.1.10. TX ABOVE 1 GHz 802.11ax HE20 MODE IN THE 5.8GHz BAND.....252

10.1.11. TX ABOVE 1 GHz 802.11ax HE40 MODE IN THE 5.8GHz BAND.....266

10.1.12. TX ABOVE 1 GHz 802.11ax HE80 MODE IN THE 5.8GHz BAND.....270

10.2. WORST CASE BELOW 30MHz.....274

10.3. WORST CASE BELOW 1 GHz.....276

10.4. WORST CASE 18-26 GHz.....278

10.5. WORST CASE 26-40 GHz.....	280
11. AC POWERLINE CONDUCTED EMISSIONS.....	282
12. SETUP PHOTOS:.....	285

1. ATTESTATION OF TEST RESULTS

COMPANY NAME: Sonos, Inc.
301 Coromar Dr
Goleta, CA 93117 USA

EUT DESCRIPTION: Wireless Smart Speaker

MODEL: S55

BRAND: Sonos

SERIAL NUMBER: Radiated: 000E58BF9FD11
Conducted: 000E58661EF23

SAMPLE RECEIPT DATE: 2024-04-01

DATE TESTED: 2024-04-01 to 2024-05-22

APPLICABLE STANDARDS	
STANDARD	TEST RESULTS
FCC 47 CFR Part 15 Subpart E	Complies
ISED RSS-247 Issue 3	Complies
ISED RSS-GEN Issue 5 + A1 + A2	Complies

UL Verification Services Inc. tested the above equipment in accordance with the requirements set forth in the above standards. The test results show that the equipment tested is capable of demonstrating compliance with the requirements as documented in this report.

The results documented in this report apply only to the tested sample, under the conditions and modes of operation as described herein. It is the manufacturer's responsibility to assure that additional production units of this model are manufactured with identical electrical and mechanical components. All samples tested were in good operating condition throughout the entire test program. Measurement Uncertainties are published for informational purposes only and were not taken into account unless noted otherwise.

This document may not be altered or revised in any way unless done so by UL Verification Services Inc. and all revisions are duly noted in the revisions section. Any alteration of this document not carried out by UL Verification Services Inc. will constitute fraud and shall nullify the document.

Approved & Released For
UL Verification Services Inc. By:

Prepared By:

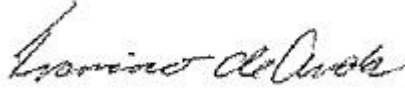

Francisco de Anda
Staff Engineer
Consumer Technology Division
UL Verification Services Inc.

Gerardo Abrego
Senior Test Engineer
Consumer Technology Division
UL Verification Services Inc.

2. TEST RESULT SUMMARY

This report contains data provided by the customer which can impact the validity of results. UL Verification Services Inc. is only responsible for correctly integrating customer-provided data with measurements performed by UL Verification Services Inc.

FCC Clause	ISED Clause	Requirement	Result	Comment
See Comment		Duty Cycle	Reporting purposes only	Per ANSI C63.10, Section 12.2.
See Comment	RSS-GEN 6.7	26dB BW/99% OBW	Reporting purposes only	Per ANSI C63.10 Sections 6.9.2 and 6.9.3
15.407 (e)	RSS-247 6.2.4.2	6 dB BW	Compliant	None.
15.407 (a) (1-3), (h) (1)	RSS-247 6.2	Output Power	Compliant	None.
15.407 (a) (1-3)	RSS-247 6.2	PSD	Compliant	None.
15.209, 15.205, 15.407 (b)	RSS-GEN 8.9, 8.10, RSS-247 6.2	Radiated Emissions	Compliant	None.
15.207	RSS-Gen 8.8	AC Mains Conducted Emissions	Compliant	None.

3. TEST METHODOLOGY

The tests documented in this report were performed in accordance with:

- FCC 47 CFR Part 2
- FCC 47 CFR Part 15
- FCC KDB 662911 D01
- FCC KDB 905462 D02 /D06
- FCC KDB 789033 D02
- KDB 414788 D01 Radiated Test Site
- ANSI C63.10-2013
- RSS-GEN Issue 5 + A1 + A2
- RSS-247 Issue 3

4. FACILITIES AND ACCREDITATION

UL Verification Services Inc. is accredited by A2LA, Certificate Number 0751.05, for all testing performed within the scope of this report. Testing was performed at the locations noted below.

	Address	ISED CABID	ISED Company Number	FCC Registration
<input checked="" type="checkbox"/>	Building 1: 47173 Benicia Street, Fremont, CA 94538, USA	US0104	2324A	550739
<input type="checkbox"/>	Building 2: 47266 Benicia Street, Fremont, CA 94538, USA			
<input type="checkbox"/>	Building 3: 843 Auburn Court, Fremont, CA 94538, USA			
<input checked="" type="checkbox"/>	Building 4: 47658 Kato Rd, Fremont, CA 94538, USA			
<input type="checkbox"/>	Building 5: 47670 Kato Rd, Fremont, CA 94538, USA			

5. DECISION RULES AND MEASUREMENT UNCERTAINTY

5.1. METROLOGICAL TRACEABILITY

All test and measuring equipment utilized to perform the tests documented in this report are calibrated on a regular basis, with a maximum time between calibrations of one year or the manufacturers' recommendation, whichever is less, and where applicable is traceable to recognized national standards.

5.2. DECISION RULES

The Decision Rule is based on Simple Acceptance in accordance with ISO Guide 98-4:2012 Clause 8.2. (Measurement uncertainty is not taken into account when stating conformity with a specified requirement.)

5.3. MEASUREMENT UNCERTAINTY

Where relevant, the following measurement uncertainty levels have been estimated for tests performed on the apparatus:

PARAMETER	U_{Lab}
Radio Frequency (Spectrum Analyzer)	141.16 Hz
Occupied Bandwidth	1.22%
Power Spectral Density	2.47 dB
RF Power Measurement Direct Method Using Power Meter	1.3 dB (PK) / 0.45 dB (AV)
Unwanted Emissions, Conducted	1.94 dB
Worst Case Conducted Disturbance, 9KHz to 0.15 MHz	3.78 dB
Worst Case Conducted Disturbance, 0.15 to 30 MHz	3.40 dB
Worst Case Radiated Disturbance, 9KHz to 30 MHz	2.87 dB
Worst Case Radiated Disturbance, 30 to 1000 MHz	6.01 dB
Worst Case Radiated Disturbance, 1000 to 18000 MHz	4.73 dB
Worst Case Radiated Disturbance, 18000 to 26000 MHz	4.51 dB
Worst Case Radiated Disturbance, 26000 to 40000 MHz	5.29 dB
Time Domain Measurements	3.39%
Temperature	0.57°C
Relative Humidity	3.39%
DC Supply Voltages	0.57%

Uncertainty figures are valid to a confidence level of 95%.

RADIATED EMISSIONS

Where relevant, the following sample calculation is provided:

$$\text{Field Strength (dBuV/m)} = \text{Measured Voltage (dBuV)} + \text{Antenna Factor (dB/m)} + \text{Cable Loss (dB)} - \text{Preamp Gain (dB)}$$
$$36.5 \text{ dBuV} + 18.7 \text{ dB/m} + 0.6 \text{ dB} - 26.9 \text{ dB} = 28.9 \text{ dBuV/m}$$

MAINS CONDUCTED EMISSIONS

Where relevant, the following sample calculation is provided:

$$\text{Final Voltage (dBuV)} = \text{Measured Voltage (dBuV)} + \text{Cable Loss (dB)} + \text{Limiter Factor (dB)} + \text{LISN Insertion Loss.}$$
$$36.5 \text{ dBuV} + 0 \text{ dB} + 10.1 \text{ dB} + 0 \text{ dB} = 46.6 \text{ dBuV}$$

6. EQUIPMENT UNDER TEST

6.1. EUT DESCRIPTION

The EUT is a Wireless Smart Speaker.

This report covers 11ax 5GHz Wifi radio.

6.2. MAXIMUM OUTPUT POWER

The transmitter has a maximum conducted output power as follows:

FCC+IC

5.2GHz BAND 802.11 ax MODE 2TX

Frequency Range (MHz)	Mode	Output Power (dBm)	Output Power (mW)
5.2 GHz band, 2TX CDD			
5180-5240	802.11ax HE20 SU	11.28	13.43
	802.11ax HE20 OFDMA, 106-Tones	9.30	8.51
	802.11ax HE20 OFDMA, 52-Tones	7.26	5.32
	802.11ax HE20 OFDMA, 26-Tones	3.69	2.34
5190-5230	802.11ax HE40 SU	13.60	22.91
5210	802.11ax HE80 SU	13.84	24.21

5.3GHz BAND 802.11 ax MODE 2TX

Frequency Range (MHz)	Mode	Output Power (dBm)	Output Power (mW)
5.3 GHz band, 2TX CDD			
5260-5320	802.11ax HE20 SU	18.23	66.53
	802.11ax HE20 OFDMA, 106-Tones	14.96	31.33
	802.11ax HE20 OFDMA, 52-Tones	13.51	22.44
	802.11ax HE20 OFDMA, 26-Tones	9.73	9.40
5270-5310	802.11ax HE40 SU	17.58	57.28
5290	802.11ax HE80 SU	14.82	30.34

5.6GHz BAND 802.11 ax MODE 2TX

Frequency Range (MHz)	Mode	Output Power (dBm)	Output Power (mW)
5.6 GHz band, 2TX CDD			
5500-5700	802.11ax HE20 SU	17.94	62.23
	802.11ax HE20 OFDMA, 106-Tones	16.01	39.90
	802.11ax HE20 OFDMA, 52-Tones	14.38	27.42
	802.11ax HE20 OFDMA, 26-Tones	10.18	10.42
5510-5670	802.11ax HE40 SU	18.26	66.99
5530-5610	802.11ax HE80 SU	19.06	80.54

5.8GHz BAND 802.11 ax MODE 2TX

Frequency Range (MHz)	Mode	Output Power (dBm)	Output Power (mW)
5.8 GHz band, 2TX CDD			
5745-5825	802.11ax HE20 SU	25.02	317.69
	802.11ax HE20 OFDMA, 106-Tones	25.75	375.84
	802.11ax HE20 OFDMA, 52-Tones	25.59	362.24
	802.11ax HE20 OFDMA, 26-Tones	25.70	371.54
5755-5795	802.11ax HE40 SU	23.69	233.88
5775	802.11ax HE80 SU	20.97	125.03

6.3. DESCRIPTION OF AVAILABLE ANTENNAS

The radio utilizes a Monopole antenna, with a maximum gain as follows.

Frequency Range (MHz)	Type	Declared Uncorrelated Gain (dBi)	Declared correlated Gain (dBi)
5150 – 5250	PCB	6.1	9.1
5250 – 5350		6.0	9.0
5500 – 5700		6.1	8.7
5725 - 5850		5.8	8.0

6.4. SOFTWARE AND FIRMWARE

The EUT firmware installed during testing was 78.1-48130-diag-jaws-dev-woosung-202312211600.

6.5. TEST REDUCTION CASE

After investigation, the output power of single user (SU) is higher than RU size 242 tone and 26 tone. Therefore, the RU size 242 tone Power and PSD data was omitted from the testing. See Maximum Output Power section(6.2).

Preliminary Investigation were performed for 802.11ax modes were determined by the following:

- Testing was performed at 802.11ax HE20 26T, 52T, 106T, SU and HE40 SU (Single User) to cover HE40 26T, 52T,106T and 242T.
- Testing was performed 802.11ax HE20 26T, 52T, 106T, SU, HE40 SU and HE80 SU (Single User) to cover HE80 26T, 52T, 106T, 242T and 484T.
- HE20 26T Harmonics and Spurious Emissions were ran at max power between 26T, 52T, 106T, 242T, 484T, 996T and SU Mode across all bandwidths and bands to cover HE20 52T,106T and SU, HE40 26T,52T,106T,242T and SU, and HE80 26T,52T,106T,242T,484T and SU as worst case power and PSD.

Also, Preliminary Investigation conducted power were performed to compare SU modes and FT (Full Tone) Tone modes. It was detemend that SU Tone modes were worst case over Full Tone mode in every instance. Therefore, only Single User was tested and represents FT mode as worst case scenario.

6.6. WORST-CASE CONFIGURATION AND MODE

Radiated emissions below 1GHz, above 18GHz, and power line conducted emission were performed with the EUT set to transmit at the channel with highest output power as worst-case scenario.

Band edge and radiated emissions between 1GHz and 18GHz were performed with the EUT set to transmit at the highest power on low, middle, and high channels.

The EUT can only be setup in desktop orientation; therefore, all radiated testing was performed with the EUT in desktop orientation.

The fundamental of the EUT was investigated in the antenna combinations, it was determined that:

ANT1 and ANT3 was the worst case in the 5.2GHz, 5.3GHz, & 5.6GHz bands.

ANT2 and ANT4 was the worst case in the 5.8GHz band.

Therefore, all final testing was performed with ANT1 and ANT3 and ANT2 and ANT4 as stated above.

Worst-case data rates as provided by the manufacturer were:

802.11ax HE20mode: MCS0

802.11ax HE40mode: MCS0

802.11ax HE80mode: MCS0

6.7. DESCRIPTION OF TEST SETUP

SUPPORT TEST EQUIPMENT						
Description	Manufacturer	Model	Serial Number	FCC ID/ DoC		
Laptop	Lenovo	X1 Carbon	R90HKAXZ	Doc		
Laptop AC/DC AC/DC Adapter	Lenovo	ADLX90NLC2A	11S45N0247Z1ZS9B54B8EJ	Doc		
USB-A to Ethernet Adapter	Plugable	USB2-E100	8CAE4CEBE0D9	Doc		
I/O CABLES (CONDUCTED TEST)						
Cable No.	Port	# of Identical Ports	Connector Type	Cable Type	Cable Length (m)	Remarks
1	AC	3	AC	Un-shielded	1.25	AC Mains to Spectrum Analyzer/AC/DC Adapter
2	DC	1	DC	Un-shielded	1	AC/DC Adapter to Laptop
3	USB-A to Ethernet Adapter	1	USB-A	Shielded	0.5	Laptop to EUT
4	Ethernet	1	RJ45	Un-shielded	1	Laptop to USB Ethernet Adapter
5	SMA Cable	1	SMA	Un-Shielded	1.0	EUT to Spectrum Analyzer
I/O CABLES (RADIATED TEST)						
Cable No.	Port	# Of Identical Ports	Connector Type	Cable Type	Cable Length (m)	Remarks

1	AC	3	AC	Un-shielded	1.25	AC Mains to Spectrum Analyzer/AC/DC Adapter
2	DC	1	DC	Un-shielded	1	AC/DC Adapter to Laptop
3	USB-A to Ethernet Adapter	1	USB-A	Shielded	0.5	Laptop to EUT
4	Ethernet	1	RJ45	Un-shielded	1	Laptop to USB Ethernet Adapter
5	SMA Cable	1	SMA	Un-Shielded	10	EUT to Horn Antenna

TEST SETUP

The EUT is a stand-alone unit, and the radio is exercised remotely by Sonos Compliance GUI test utility software via ethernet.

SETUP DIAGRAM

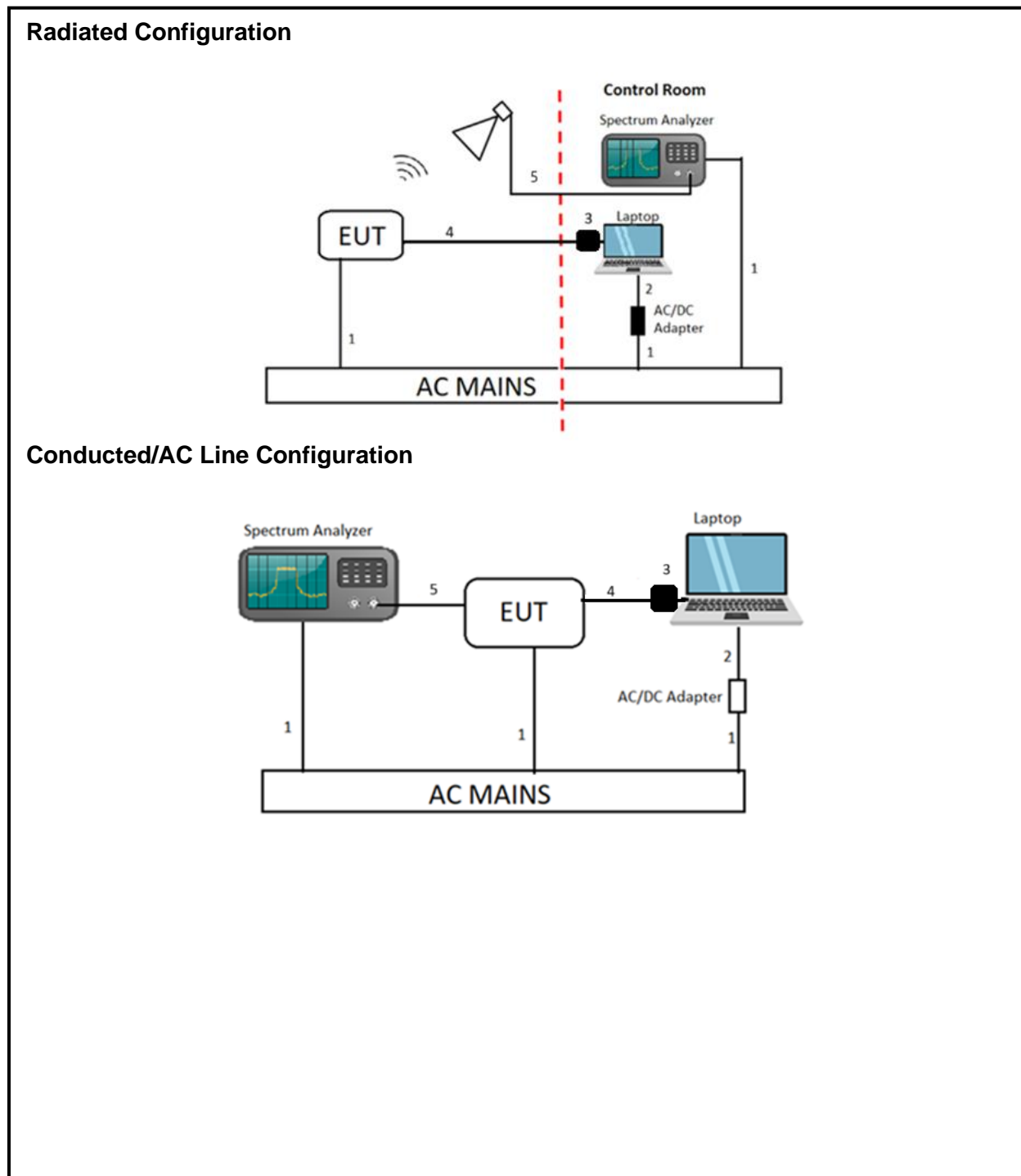

7. MEASUREMENT METHOD

On Time and Duty Cycle: KDB 789033 D02 v02r01, Section B.

6 dB Emission BW: KDB 789033 D02 v02r01, Section C.2

26 dB Emission BW: KDB 789033 D02 v02r01, Section C.1

99% Occupied BW: KDB 789033 D02 v02r01, Section D.

Conducted Output Power: KDB 789033 D02 v02r01, Section E.3.b (Method PM-G) and KDB 789033 D02 v02r01, Section E.2.b (Method SA-1)

Power Spectral Density: KDB 789033 D02 v02r01, Section F

Unwanted emissions in restricted bands: KDB 789033 D02 v02r01, Sections G.3, G.4, G.5, and G.6.

Unwanted emissions in non-restricted bands: KDB 789033 D02 v02r01, Sections G.3, G.4, and G.5.

AC Power Line Conducted Emissions: ANSI C63.10-2013, Section 6.2.

Radiated Spurious Emissions Below 30MHz: ANSI C63.10-2013 Section 6.4

8. TEST AND MEASUREMENT EQUIPMENT

The following test and measurement equipment was utilized for the tests documented in this report:

TEST EQUIPMENT LIST					
Description	Manufacturer	Model	ID Num	Cal Due	Last Cal
Antenna, Broadband Hybrid, 30MHz to 2GHz	Sunol Sciences Corp.	JB1	80293	2024-04-30*	2023-04-11
Amplifier, 9KHz to 1GHz, 32dB	SONOMA INSTRUMENT	310	213877	2025-03-31	2024-03-25
Antenna, Horn 1-18GHz	ETS-Lindgren (Cedar Park, Texas)	3117	222741	2024-08-31	2022-08-31
Antenna, Horn 1-18GHz	ETS-Lindgren (Cedar Park, Texas)	3117	206805	2024-07-31	2023-07-11
Antenna, Horn 1-18GHz	ETS-Lindgren (Cedar Park, Texas)	3117	80404	2024-08-31	2023-08-31
RF Filter Box, 1-18GHz	FREMONT	6 Port Silver box	171013	2024-05-31	2023-05-04
RF Filter Box, 1-18GHz	FREMONT	n/a	171875	2025-03-31	2024-03-23
EMI TEST RECEIVER	Rohde & Schwarz	ESW44	191429	2025-02-28	2024-02-11
EMI TEST RECEIVER	Rohde & Schwarz	ESW44	230547	2025-02-28	2024-02-11
EMI TEST RECEIVER	Rohde & Schwarz	ESW44	225688 (chamber k)	2025-02-11	2024-02-11
Antenna, Horn 18 to 26.5GHz	ARA	MWH-1826/B	199659	2024-12-31	2022-12-06
Amplifier 18-26.5GHz, +5Vdc, 60dB min	AMPLICAL	AMP18G26.5-60	234683	2025-03-31	2024-03-31
Antenna, Passive Loop 30Hz - 1MHz	ELECTRO METRICS	EM-6871	219908	2024-09-30	2023-09-13
Antenna, Passive Loop 100KHz - 30MHz	ELECTRO METRICS	EM-6872	219910	2024-05-31	2023-05-31
Spectrum Analyzer, PXA, 2Hz to 26.5GHz	Keysight Technologies Inc	N9030B	245121	2025-02-07	2024-02-07
Power Meter, P-series single channel	Keysight Technologies Inc	N1911A	90718	2025-01-31	2024-01-25
Power Sensor, P - series, 50MHz to 18GHz, Wideband	Keysight Technologies Inc	N1921A	90388	2024-06-30	2023-06-23
AC Line Conducted					
LISN	Fischer Custom Communications, Inc`	FCC-LISN-50/250-25-2-01-480V	175765	2025-01-31	2024-01-26
EMI TEST RECEIVER	Rohde & Schwarz	ESR	171646	2025-02-28	2024-02-27
Transient Limiter	TE	TBFL1	127455	2025-02-28	2024-02-27
UL TEST SOFTWARE LIST					
Radiated Software	UL	UL EMC	Ver 2023-05-01		
Antenna Port Software	UL	UL RF	Ver 2022-08-16		
AC Line Conducted Software	UL	UL EMC	Rev 9.5, 2023-03-03		

* Testing performed before expiration date

9. ANTENNA PORT TEST RESULTS

9.1. ON TIME AND DUTY CYCLE

LIMITS

None; for reporting purposes only.

PROCEDURE

KDB 558074 D01 Zero-Span Spectrum Analyzer Method.

Test Engineer:	ZS 16080
Test Date:	2024-04-03, 2024-04-05

ON TIME AND DUTY CYCLE RESULTS

Mode	ON Time B (msec)	Period (msec)	Duty Cycle x (linear)	Duty Cycle (%)	Duty Cycle Correction Factor (dB)	1/B Minimum VBW (kHz)
802.11ax HE20 OFDMA, SU	4.099	4.855	0.844	84.43	0.74	0.244
802.11ax HE20 OFDMA, RU size 106T	0.436	1.039	0.419	41.92	3.78	2.296
802.11ax HE20 OFDMA, RU size 52T	0.494	0.639	0.774	77.40	1.11	2.023
802.11ax HE20 OFDMA, RU size 26T	0.579	1.181	0.490	49.00	3.10	1.728
802.11ax HE40 OFDMA, SU	2.077	2.815	0.738	73.78	1.32	0.481
802.11ax HE80 OFDMA, SU	1.024	1.770	0.579	57.85	2.38	0.977

DUTY CYCLE PLOTS

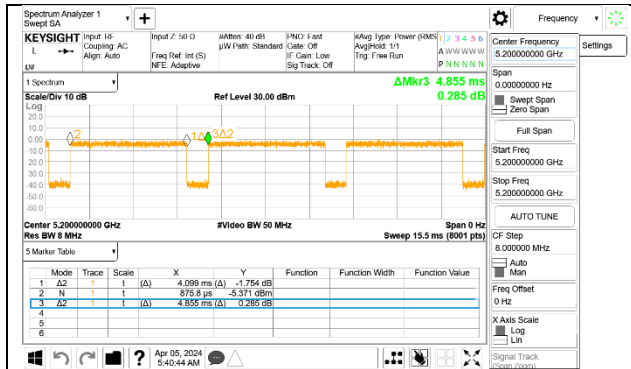

802.11ax HE20 OFDMA, OFDMA MODE: SU

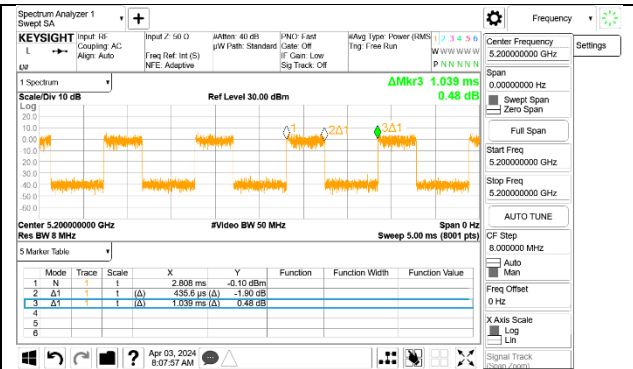

802.11ax HE20 OFDMA, RU size 106T MODE



802.11ax HE20 OFDMA, RU size 52T MODE

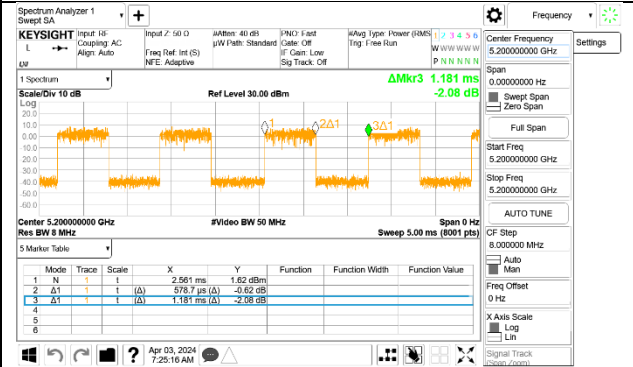

802.11ax HE20 OFDMA, RU size 26T MODE

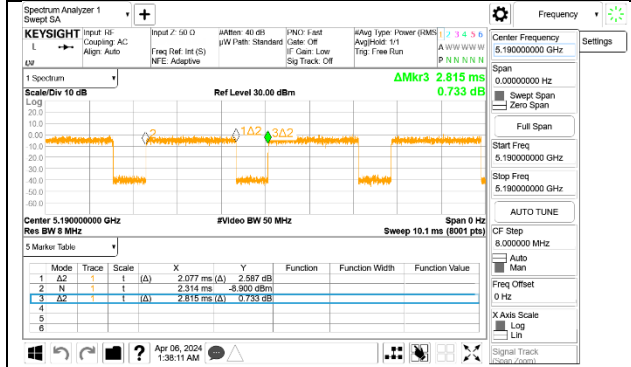

802.11ax HE40 OFDMA, OFDMA MODE: SU

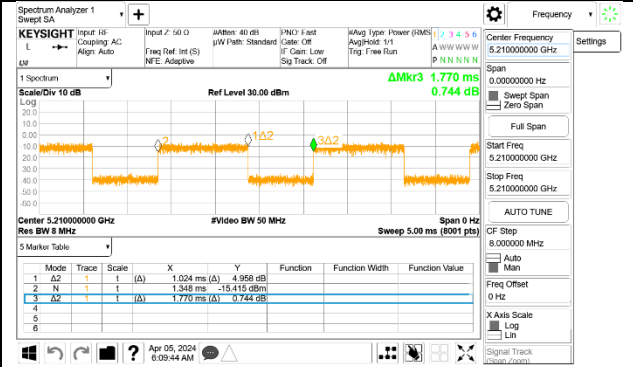

802.11ax HE80 OFDMA, OFDMA MODE: SU

9.2. 26 dB BANDWIDTH

LIMITS

None; for reporting purposes only.

RESULTS

9.2.1. 802.11ax HE20 MODE 2TX IN THE 5.2GHz BAND

2TX Antenna 1 + Antenna 3 CDD OFDMA MODE: 106-Tones, RU Index 53(L/M), 54(H)

Frequency (MHz)	26 dB Bandwidth Antenna 1 (MHz)	26 dB Bandwidth Antenna 3 (MHz)
5180	19.52	20.60
5200	19.72	19.84
5240	19.92	20.48

LOW CHANNEL

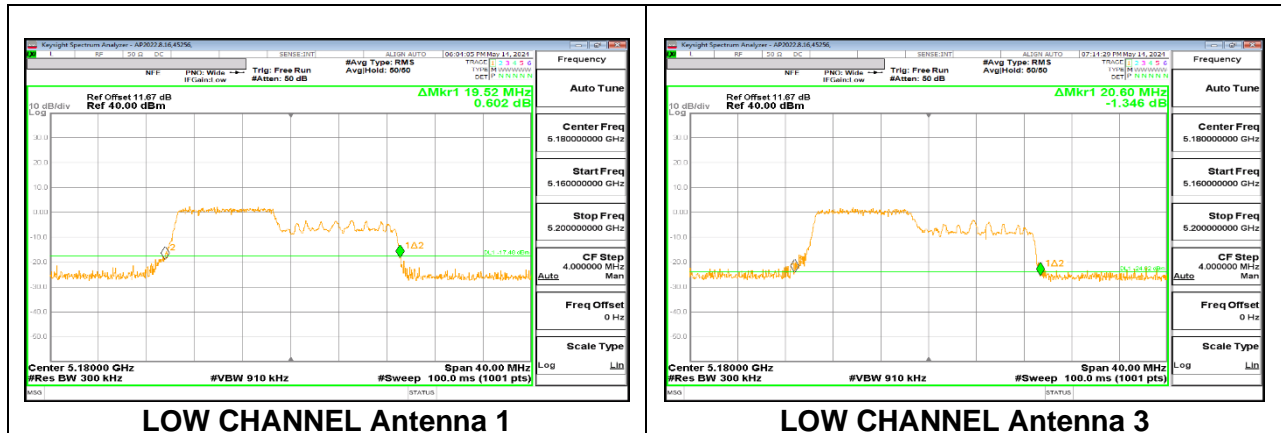

MID CHANNEL

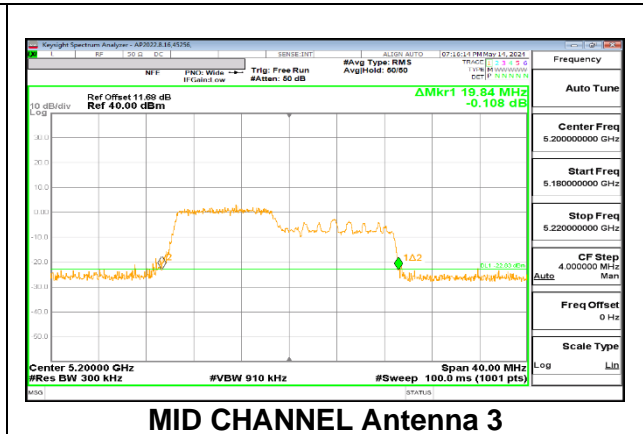
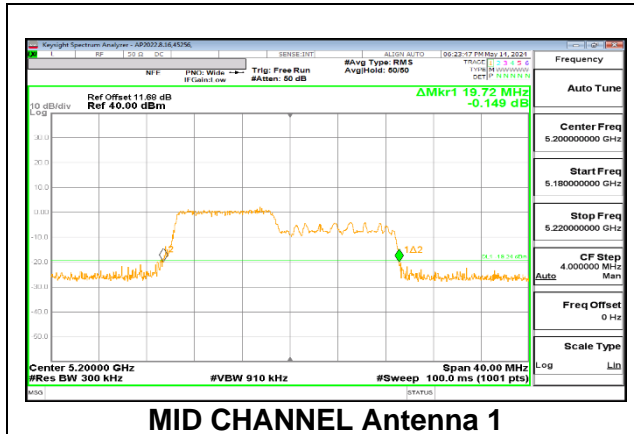

HIGH CHANNEL

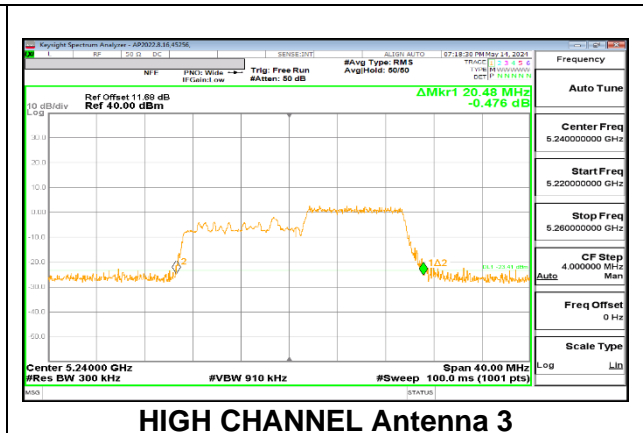
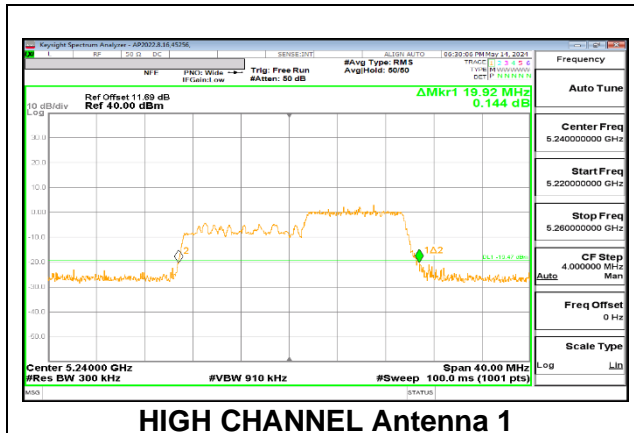

2TX Antenna 1 + Antenna 3 CDD OFDMA MODE: 52-Tones, RU Index 37(L), 38(M), 40(H)

Frequency (MHz)	26 dB Bandwidth Antenna 1 (MHz)	26 dB Bandwidth Antenna 3 (MHz)
5180	21.88	21.56
5200	18.48	18.44
5240	22.68	21.48

LOW CHANNEL

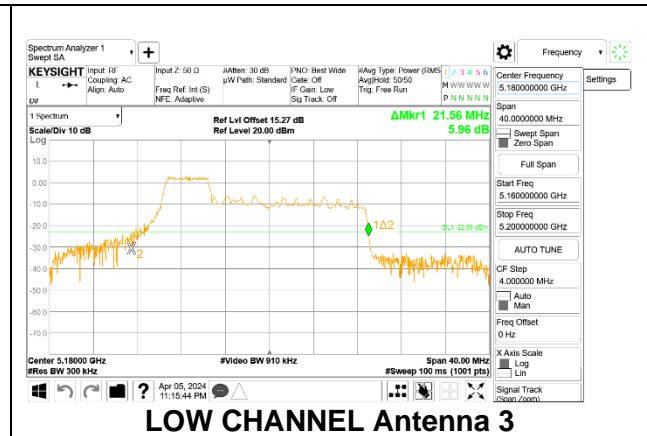
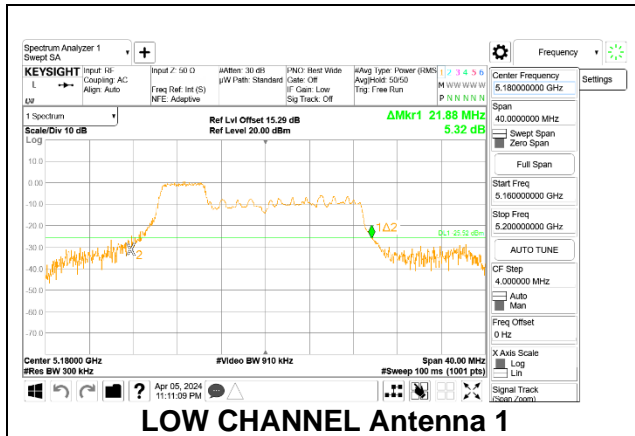

MID CHANNEL

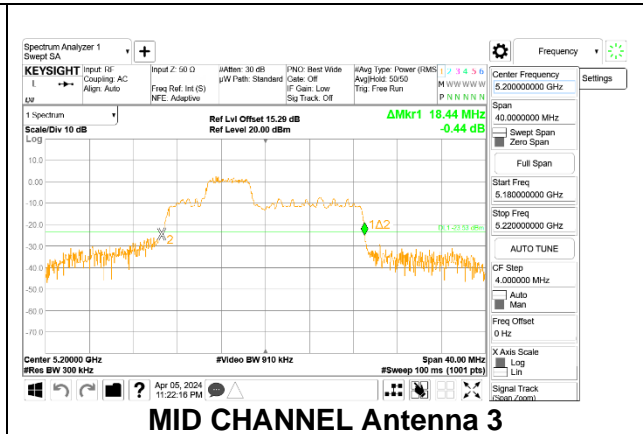
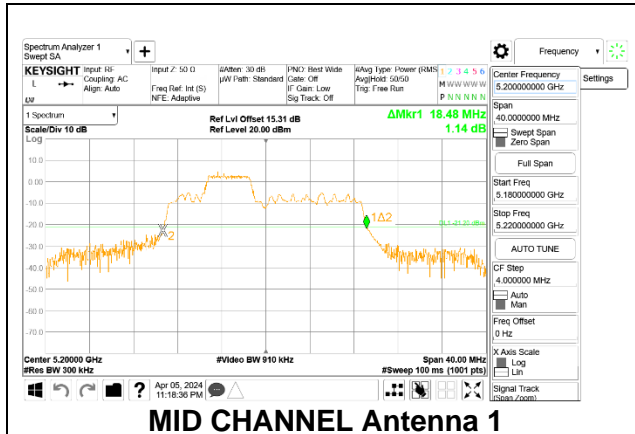

HIGH CHANNEL

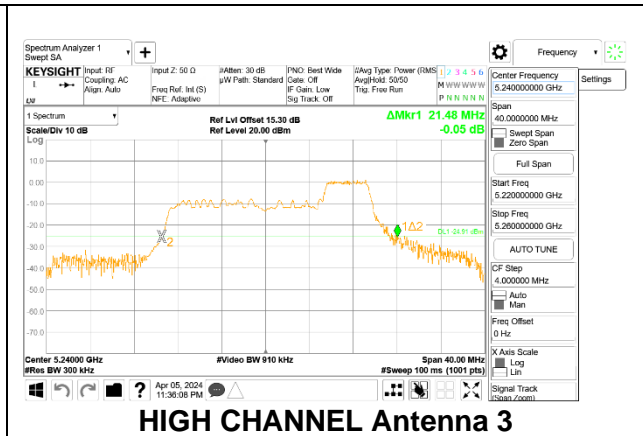
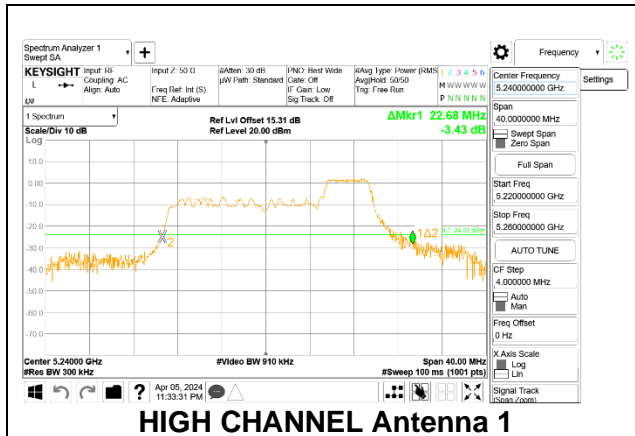

2TX Antenna 1 + Antenna 3 CDD OFDMA MODE: 26-Tones, RU Index 0(L), 4(M), 8(H)

Frequency (MHz)	26 dB Bandwidth Antenna 1 (MHz)	26 dB Bandwidth Antenna 3 (MHz)
5180	20.80	20.36
5200	18.20	18.24
5240	20.84	20.76

LOW CHANNEL

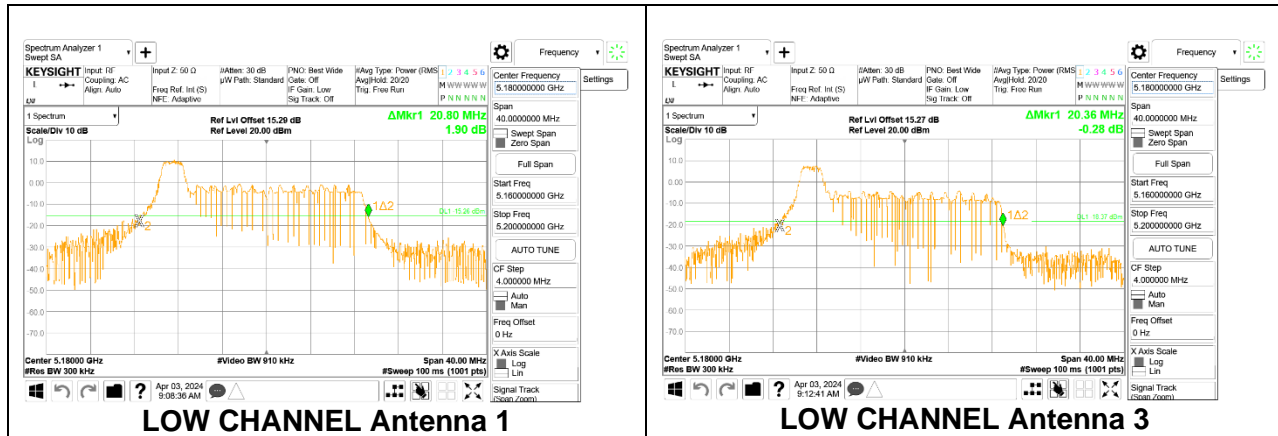

MID CHANNEL

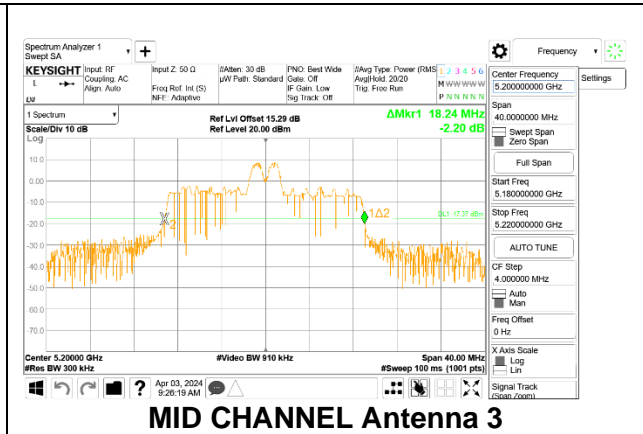
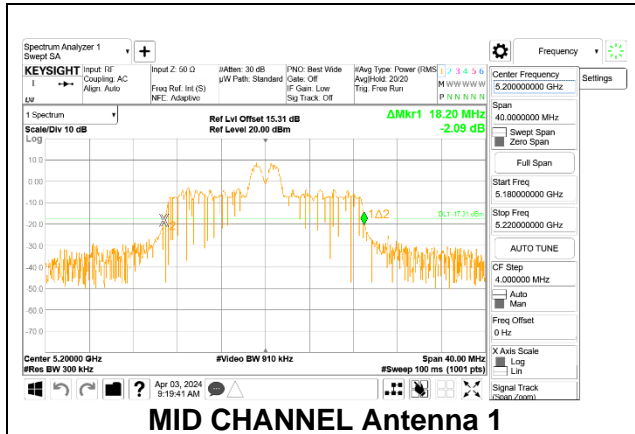

HIGH CHANNEL

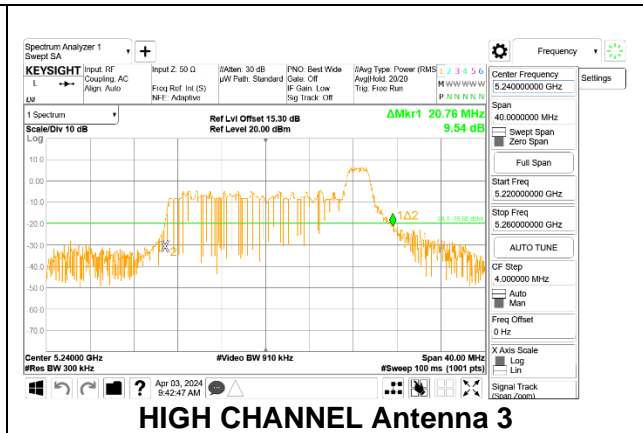
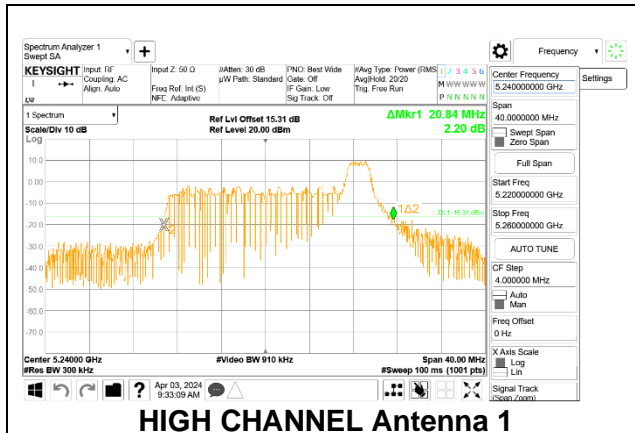

2TX Antenna 1 + Antenna 3 CDD OFDMA MODE: SU (Single User)

Frequency (MHz)	26 dB Bandwidth Antenna 1 (MHz)	26 dB Bandwidth Antenna 3 (MHz)
5180	22.56	22.48
5200	22.60	23.44
5240	22.36	22.08

LOW CHANNEL

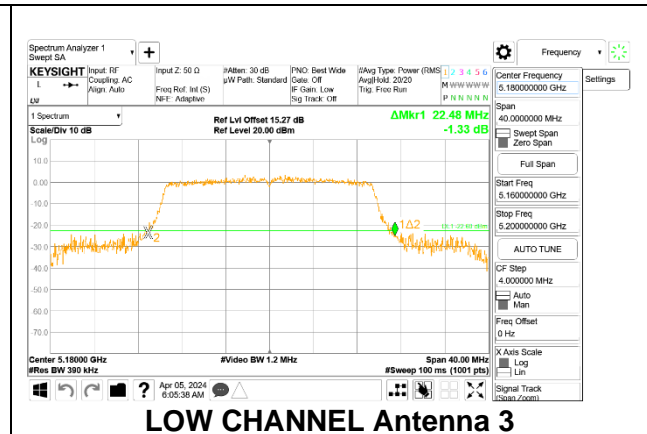
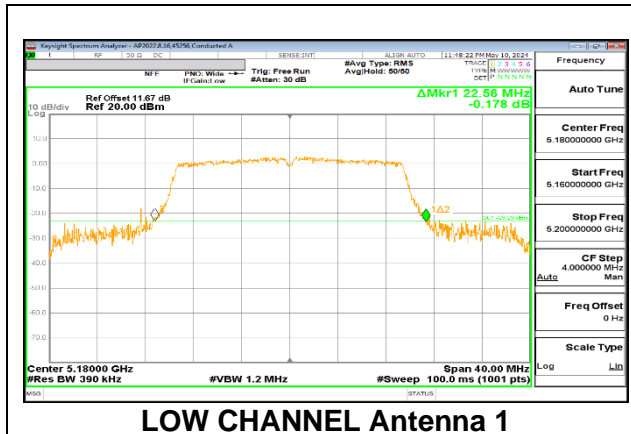

MID CHANNEL

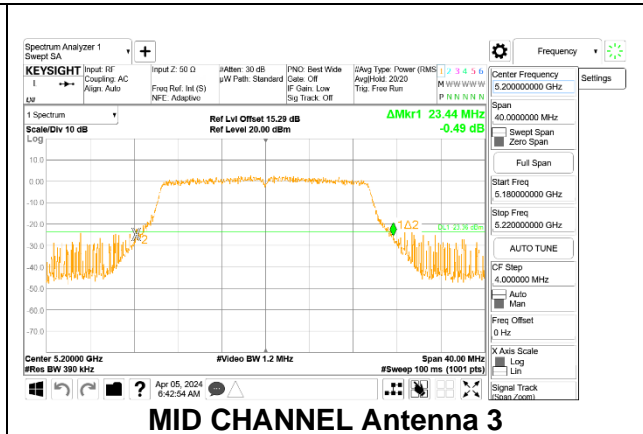
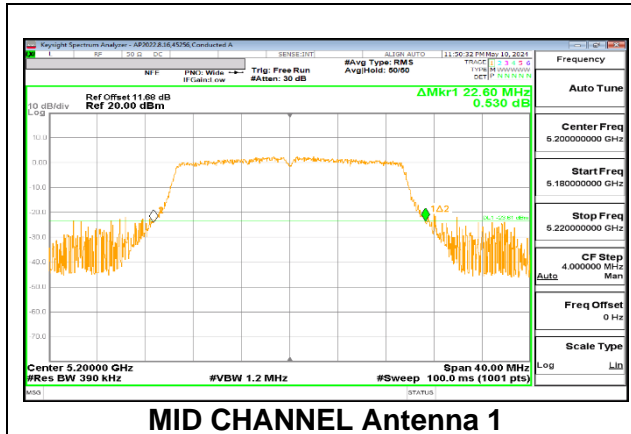

HIGH CHANNEL

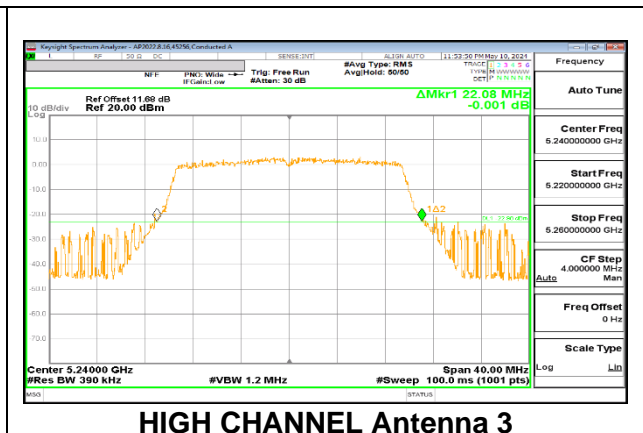
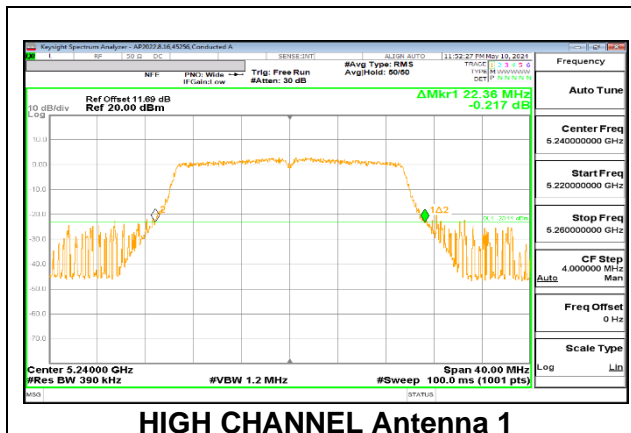

9.2.2. 802.11ax HE40 MODE 2TX IN THE 5.2GHZ BAND

2TX Antenna 1 + Antenna 3 CDD OFDMA MODE: SU (Single User)

Channel	Frequency (MHz)	26 dB Bandwidth Antenna 1 (MHz)	26 dB Bandwidth Antenna 3 (MHz)
Low	5190	40.16	40.32
High	5230	40.40	40.24

LOW CHANNEL

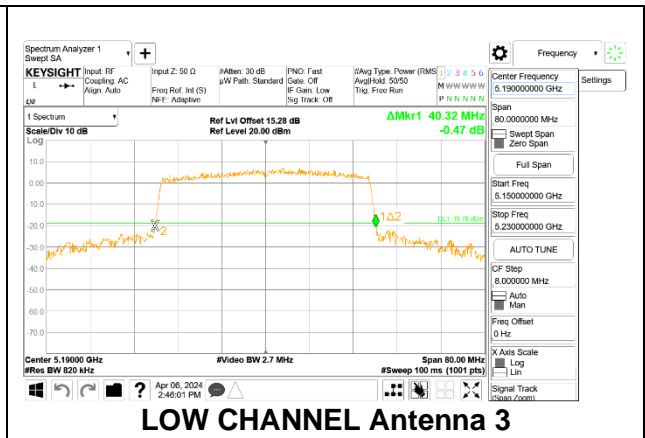
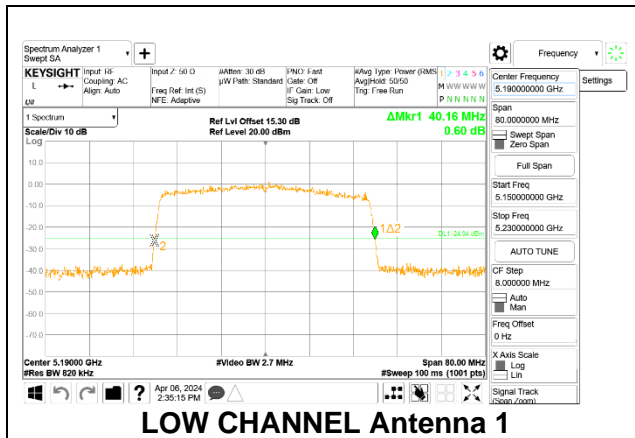

HIGH CHANNEL

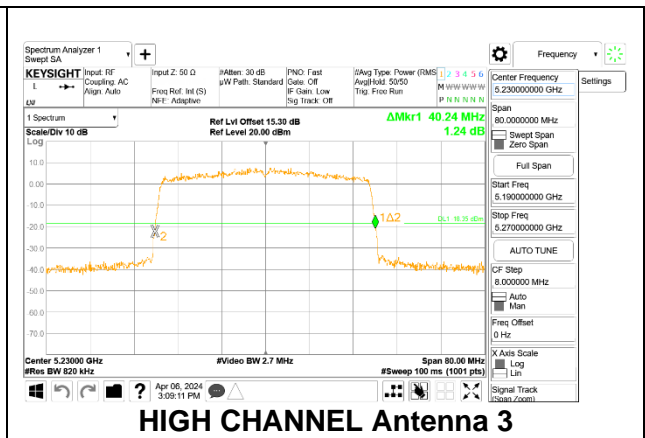
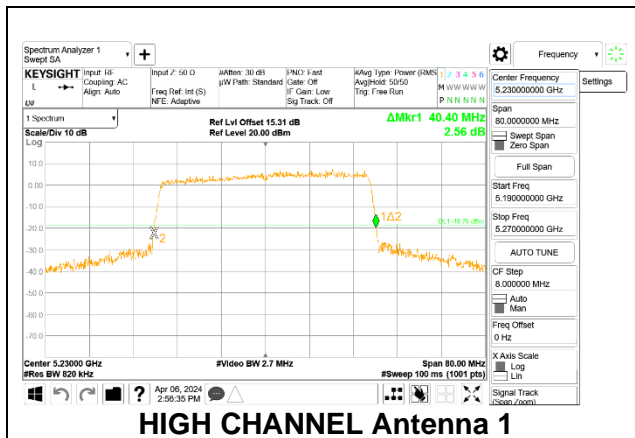

9.2.3. 802.11ax HE80 MODE 2TX IN THE 5.2GHz BAND

2TX Antenna 1 + Antenna 3 CDD OFDMA MODE: SU (Single User)

Channel	Frequency (MHz)	26 dB Bandwidth Antenna 1 (MHz)	26 dB Bandwidth Antenna 3 (MHz)
Mid	5210	81.60	81.60

MID CHANNEL

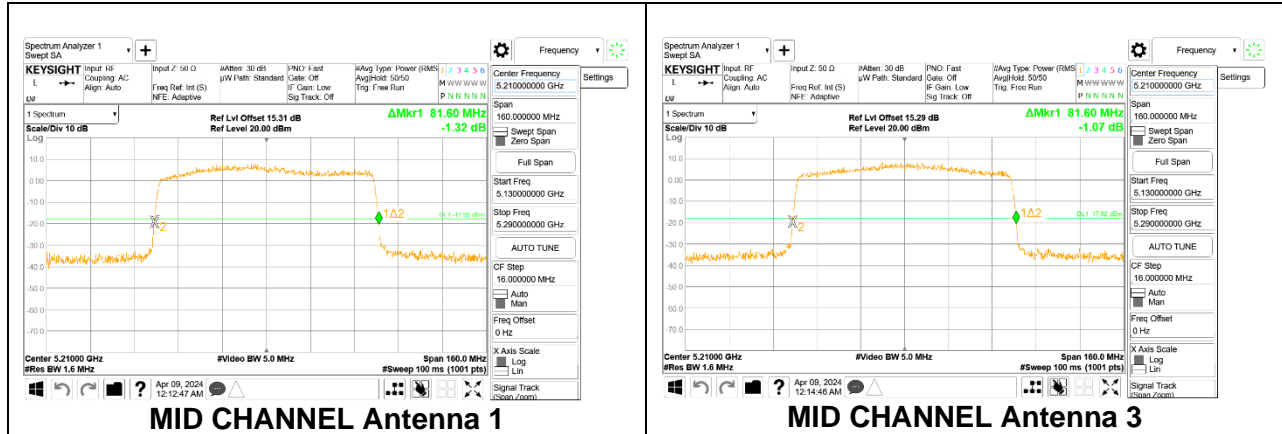

9.2.4. 802.11ax HE20 MODE 2TX IN THE 5.3GHZ BAND

2TX Antenna 1 + Antenna 3 CDD OFDMA MODE: 106-Tones, RU Index 53(L/M), 54(H)

Frequency (MHz)	26 dB Bandwidth Antenna 1 (MHz)	26 dB Bandwidth Antenna 3 (MHz)
5260	19.52	20.64
5300	19.56	20.44
5320	20.40	20.40

LOW CHANNEL

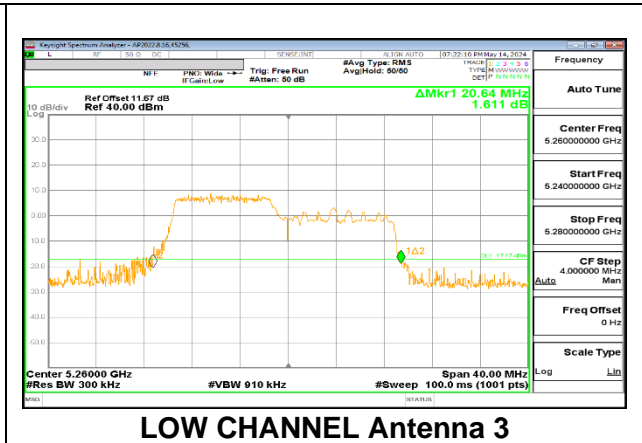
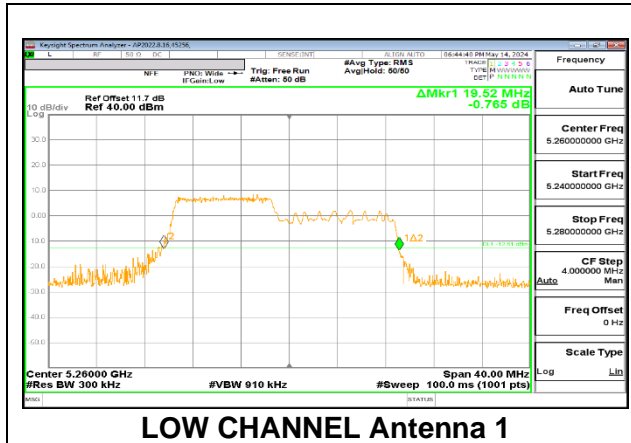

MID CHANNEL

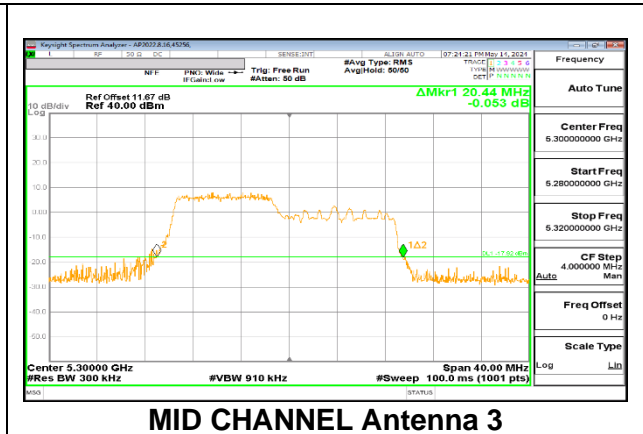
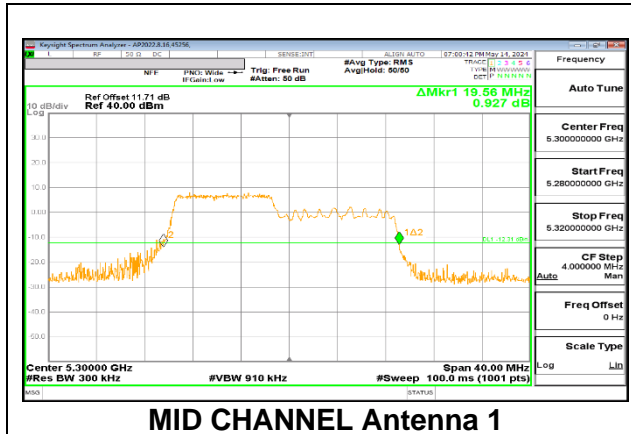

HIGH CHANNEL

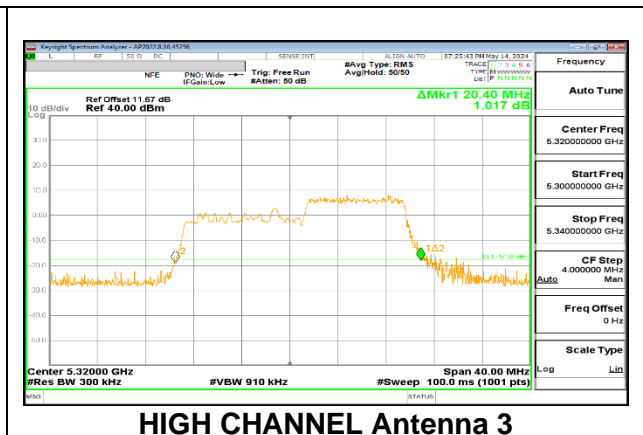
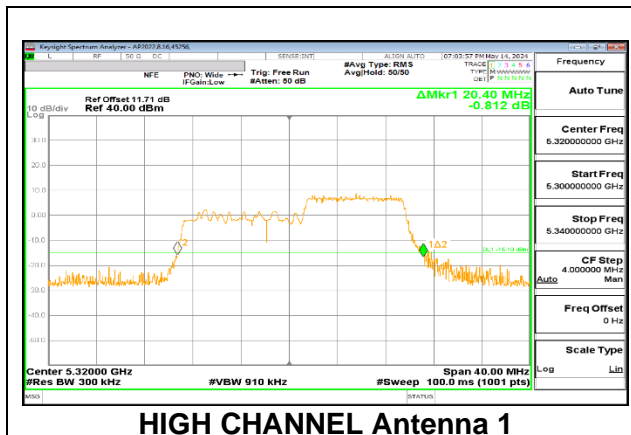

2TX Antenna 1 + Antenna 3 CDD OFDMA MODE: 52-Tones, RU Index 37(L), 38(M), 40(H)

Frequency (MHz)	26 dB Bandwidth Antenna 1 (MHz)	26 dB Bandwidth Antenna 3 (MHz)
5260	20.52	20.68
5300	18.64	18.48
5320	21.08	21.20

LOW CHANNEL

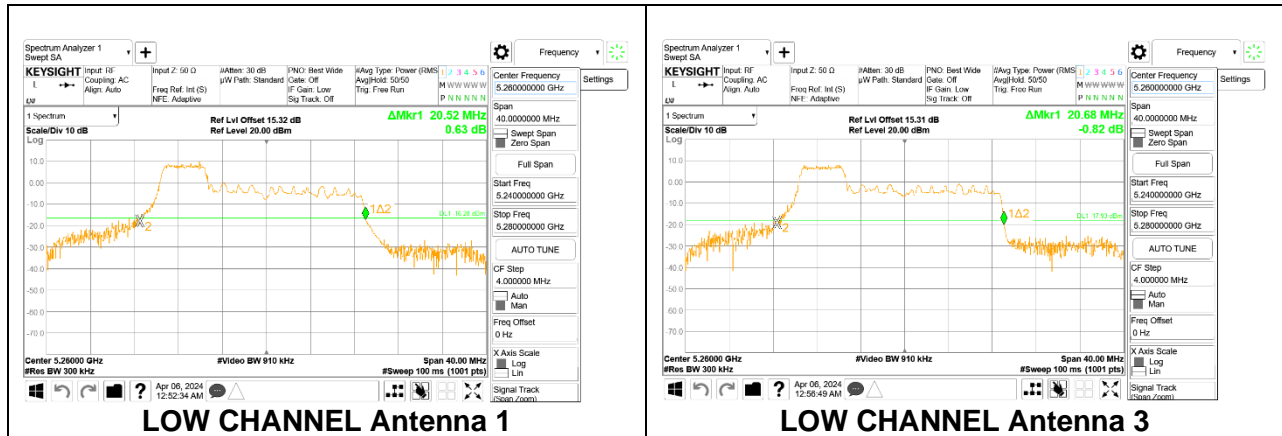

MID CHANNEL

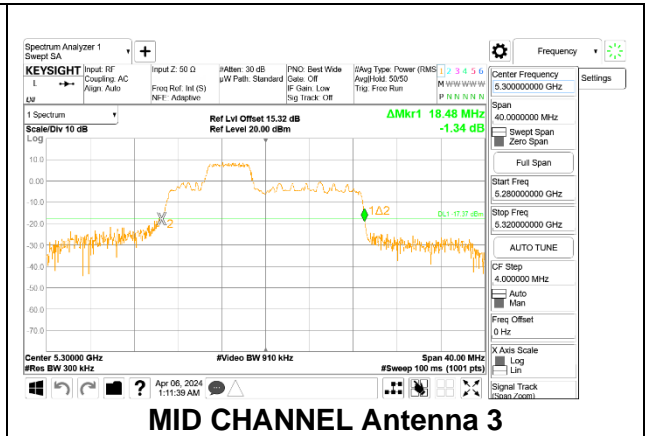
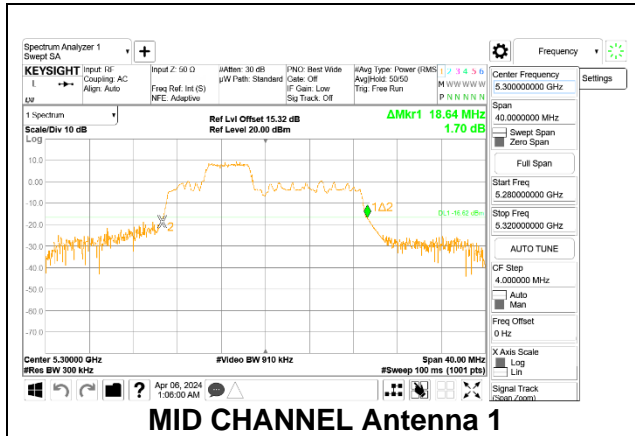

HIGH CHANNEL

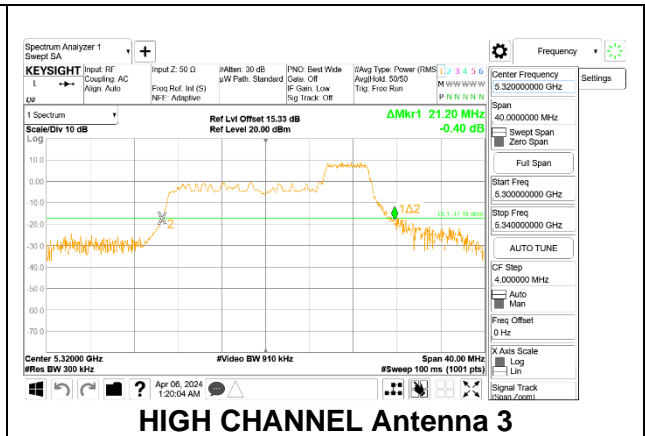
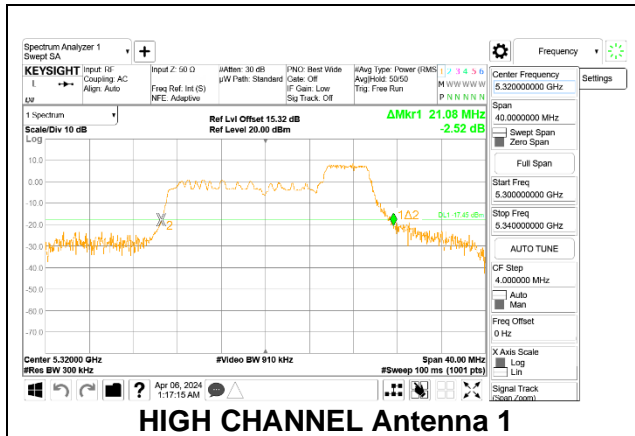

2TX Antenna 1 + Antenna 3 CDD OFDMA MODE: 26-Tones, RU Index 0(L), 4(M), 8(H)

Frequency (MHz)	26 dB Bandwidth Antenna 1 (MHz)	26 dB Bandwidth Antenna 3 (MHz)
5260	20.32	20.32
5300	18.28	18.20
5320	21.00	20.92

LOW CHANNEL

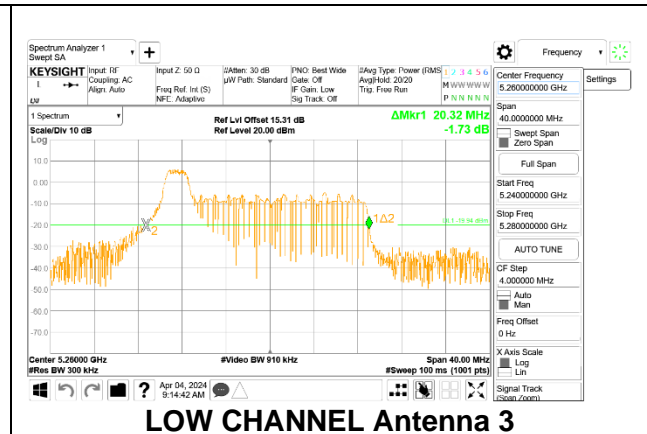
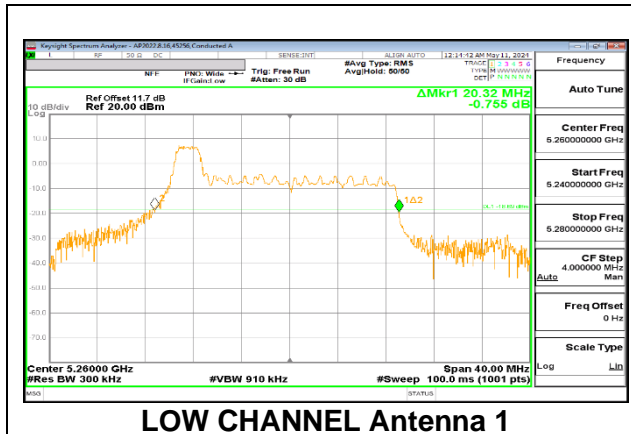

MID CHANNEL

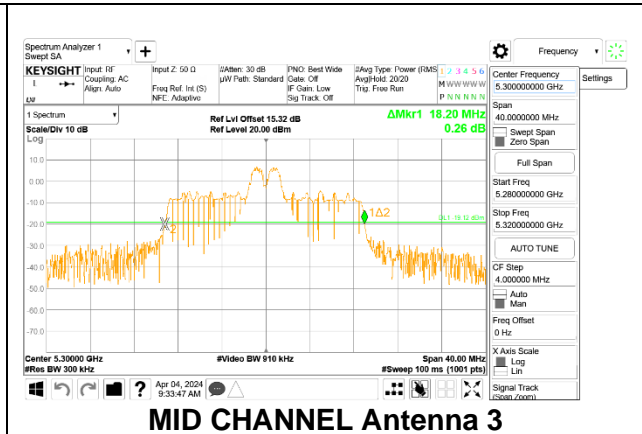
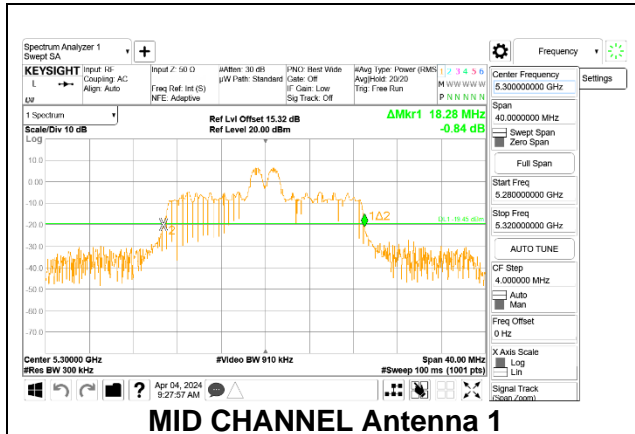

HIGH CHANNEL

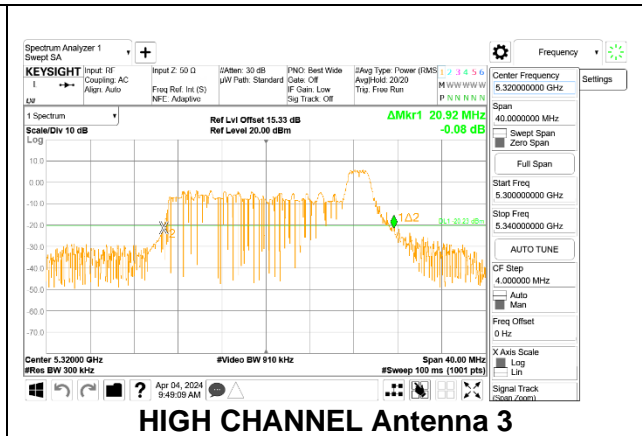
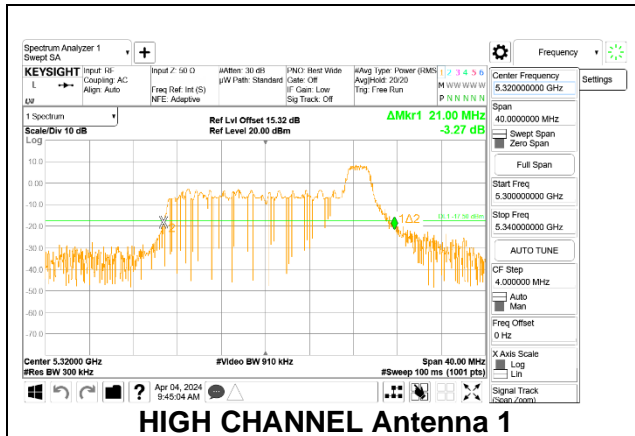

2TX Antenna 1 + Antenna 3 CDD OFDMA MODE: SU (Single User)

Channel	Frequency (MHz)	26 dB Bandwidth Antenna 1 (MHz)	26 dB Bandwidth Antenna 3 (MHz)
Low	5260	22.52	22.40
Mid	5300	22.88	22.12
High	5320	22.68	21.92

LOW CHANNEL

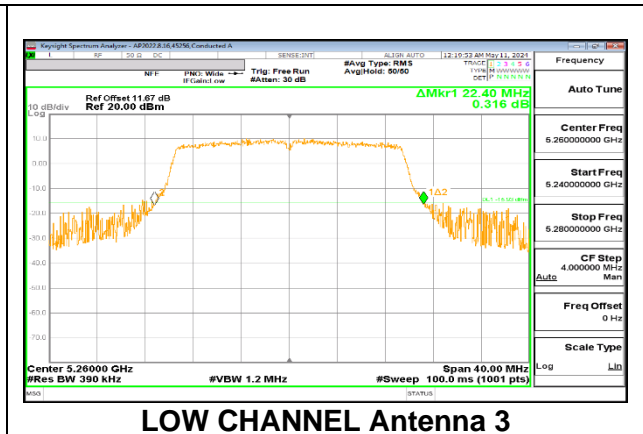
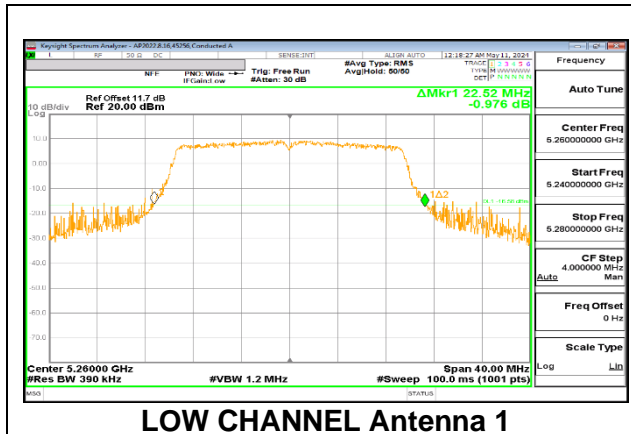

MID CHANNEL

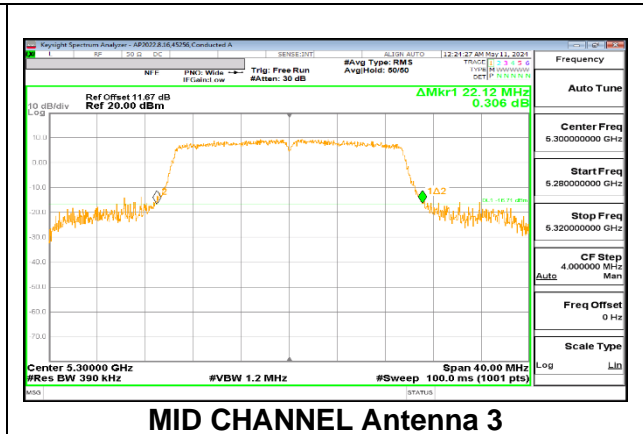
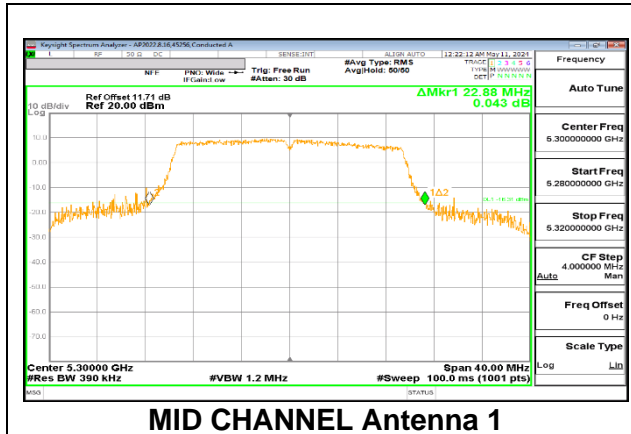

HIGH CHANNEL

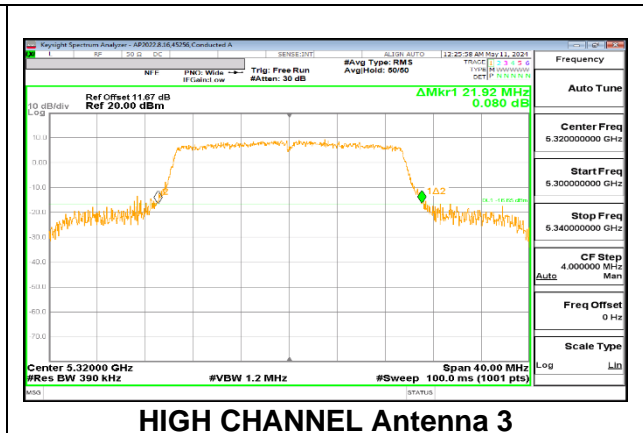
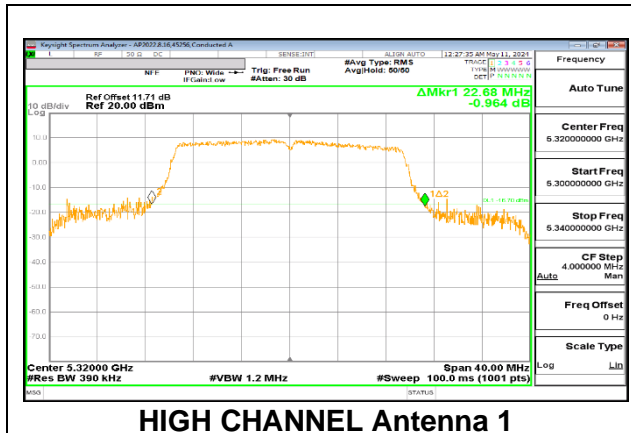

9.2.5. 802.11ax HE40 MODE 2TX IN THE 5.3GHZ BAND

2TX Antenna 1 + Antenna 3 CDD OFDMA MODE: SU (Single User)

Channel	Frequency (MHz)	26 dB Bandwidth Antenna 1 (MHz)	26 dB Bandwidth Antenna 3 (MHz)
Low	5270	40.24	40.24
High	5310	40.24	40.00

LOW CHANNEL

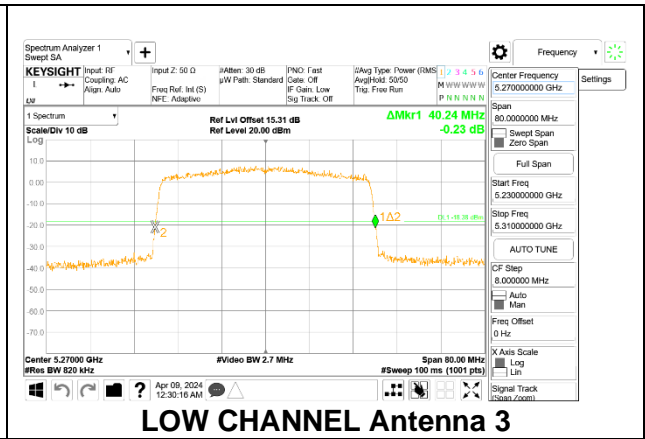
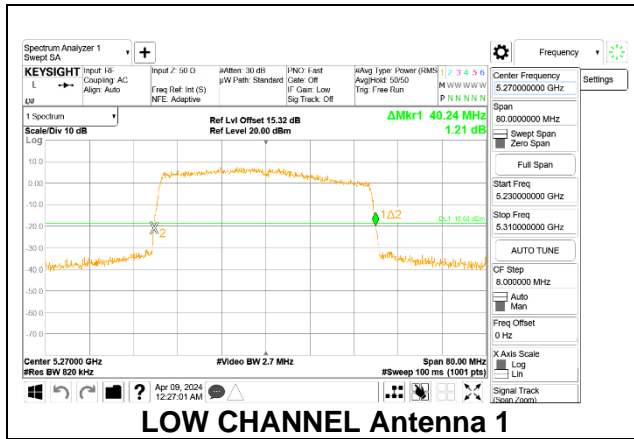

HIGH CHANNEL

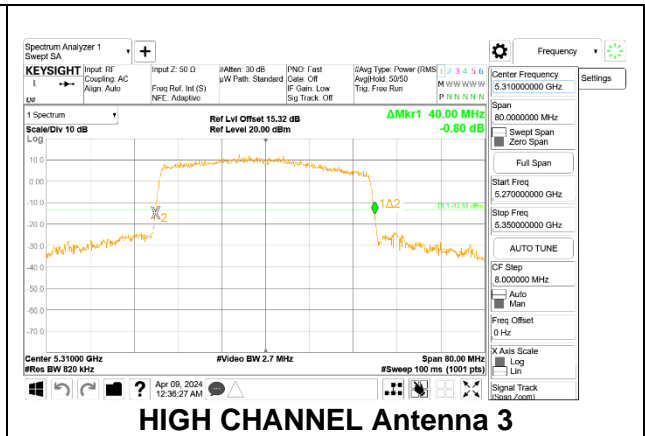
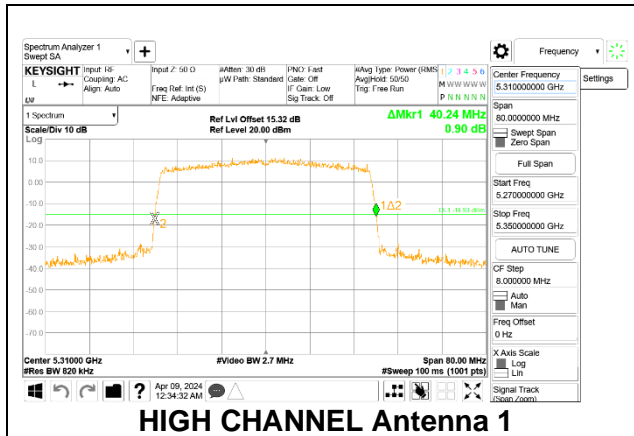

9.2.6. 802.11ax HE80 MODE 2TX IN THE 5.3GHz BAND

2TX Antenna 1 + Antenna 3 CDD OFDMA MODE: SU (Single User)

Channel	Frequency (MHz)	26 dB Bandwidth Antenna 1 (MHz)	26 dB Bandwidth 3 (MHz)
Mid	5290	81.92	81.60

MID CHANNEL

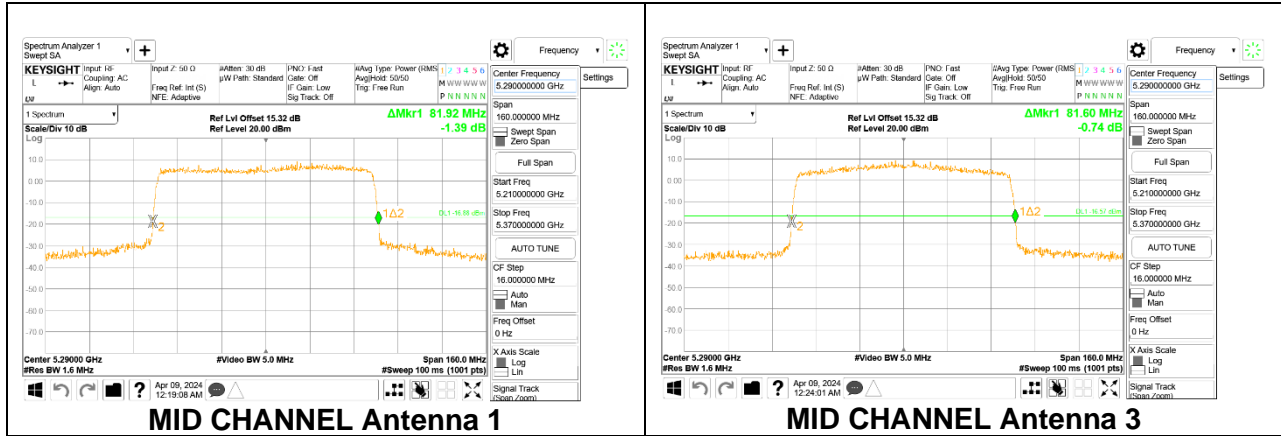

9.2.7. 802.11ax HE20 MODE 2TX IN THE 5.6GHZ BAND

2TX Antenna 1 + Antenna 3 CDD OFDMA MODE: 106-Tones, RU Index 53(L/M), 54(H)

Frequency (MHz)	26 dB Bandwidth Antenna 1 (MHz)	26 dB Bandwidth Antenna 3 (MHz)
5500	20.76	20.64
5580	20.64	20.56
5700	20.88	20.80

LOW CHANNEL

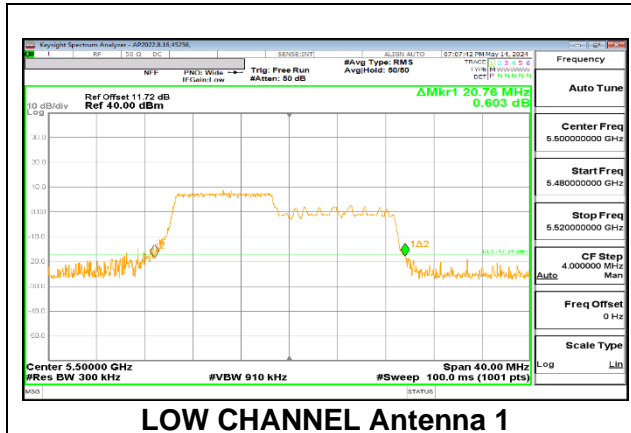

LOW CHANNEL Antenna 1

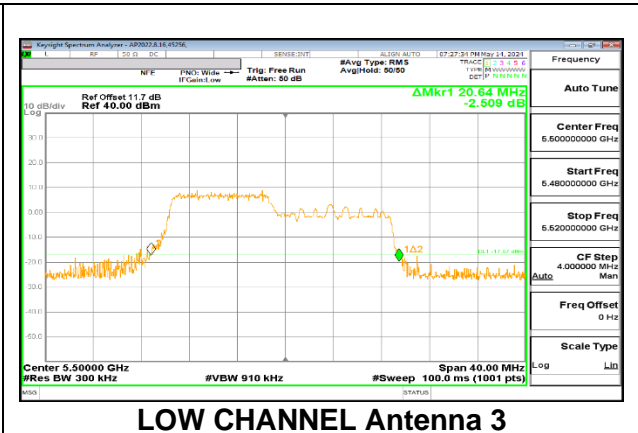

LOW CHANNEL Antenna 3

MID CHANNEL

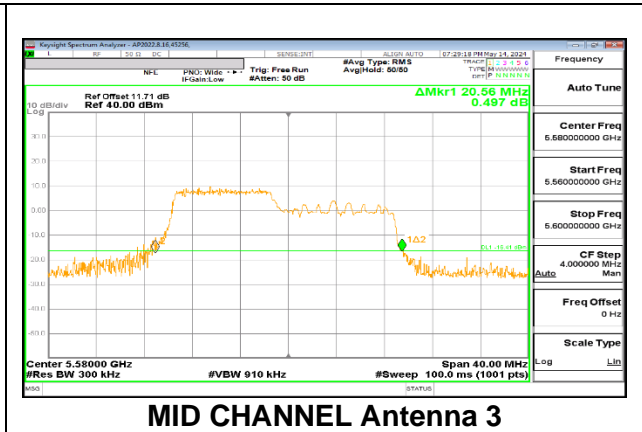
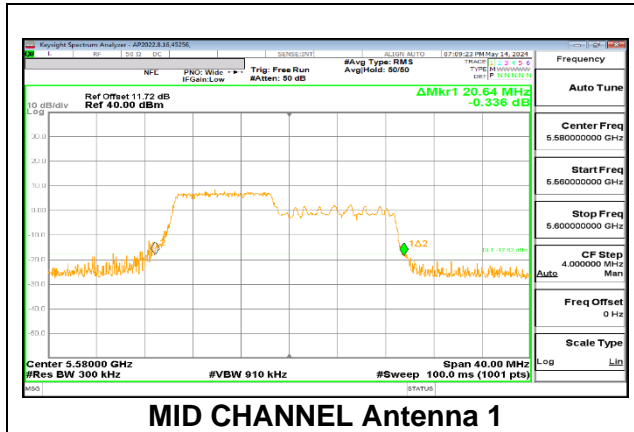

HIGH CHANNEL

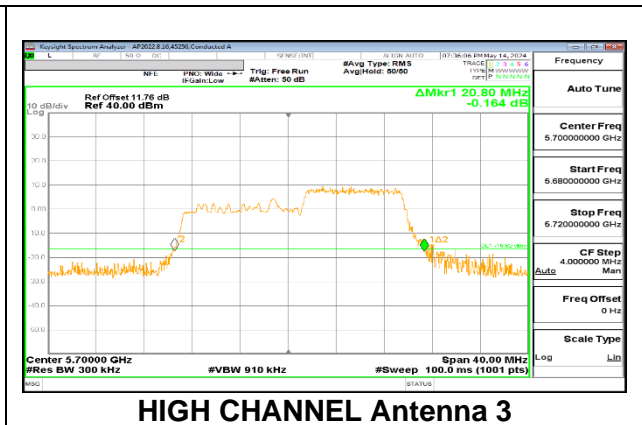
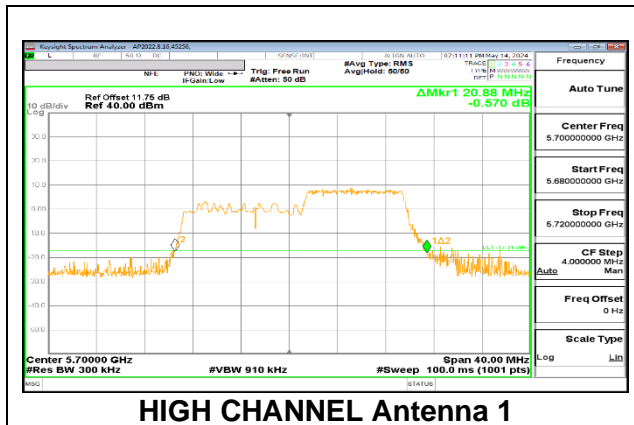

2TX Antenna 1 + Antenna 3 CDD OFDMA MODE: 52-Tones, RU Index 37(L), 38(M), 40(H)

Frequency (MHz)	26 dB Bandwidth Antenna 1 (MHz)	26 dB Bandwidth Antenna 3 (MHz)
5500	21.40	20.68
5580	18.48	18.52
5700	21.32	21.60

LOW CHANNEL

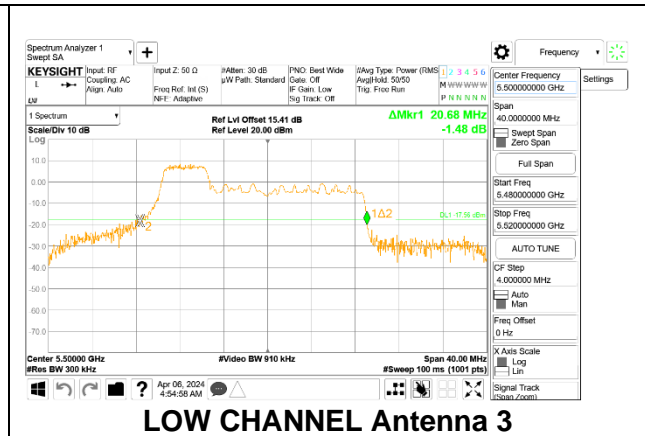
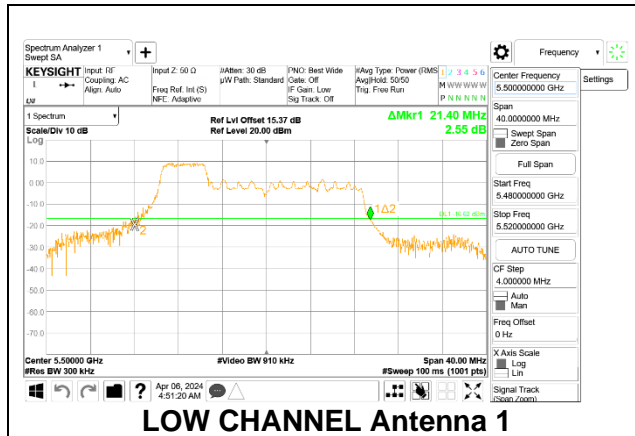

MID CHANNEL

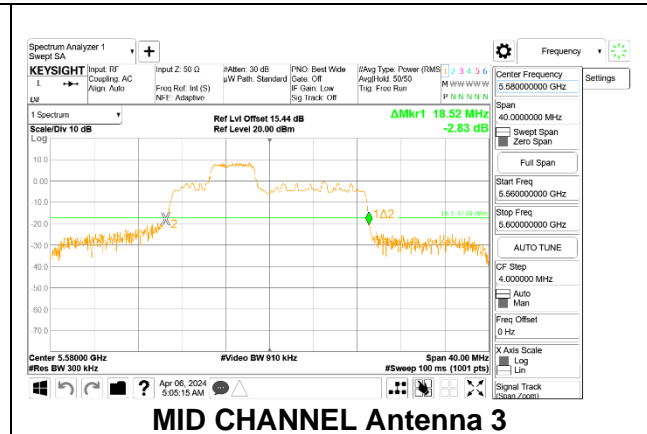
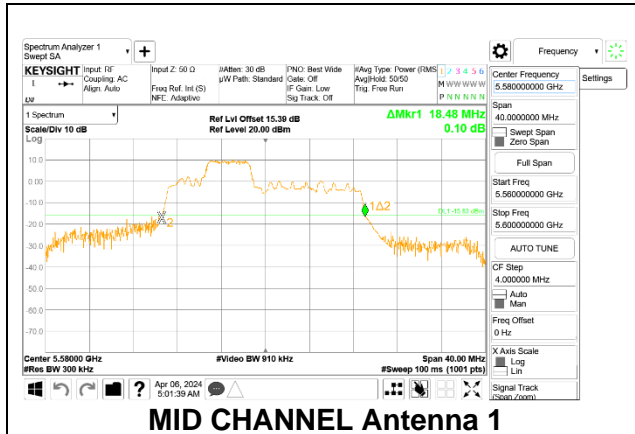

HIGH CHANNEL

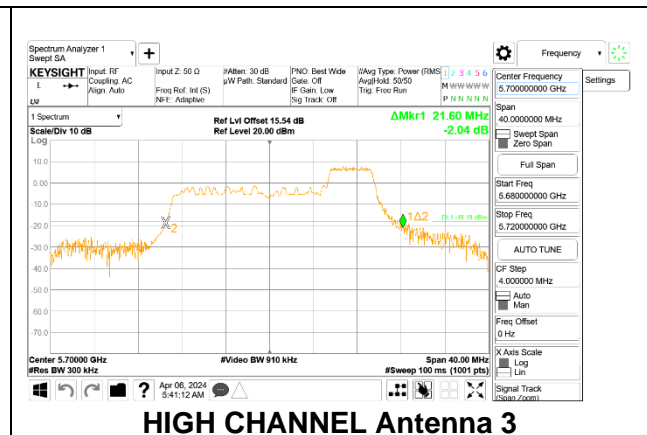
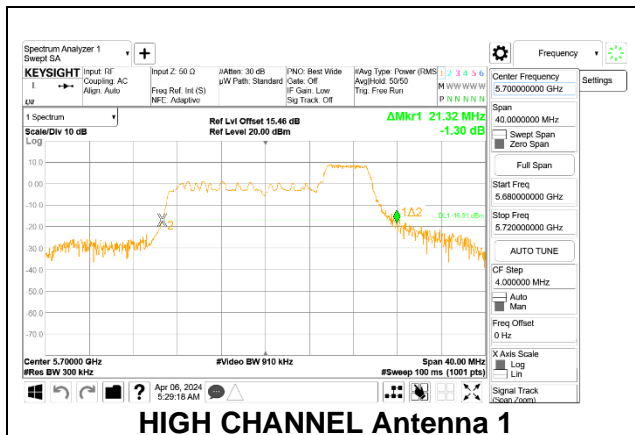

2TX Antenna 1 + Antenna 3 CDD OFDMA MODE: 26-Tones, RU Index 0(L), 4(M), 8(H)

Frequency (MHz)	26 dB Bandwidth Antenna 1 (MHz)	26 dB Bandwidth Antenna 3 (MHz)
5500	20.32	20.44
5580	18.28	18.24
5700	20.64	20.80

LOW CHANNEL

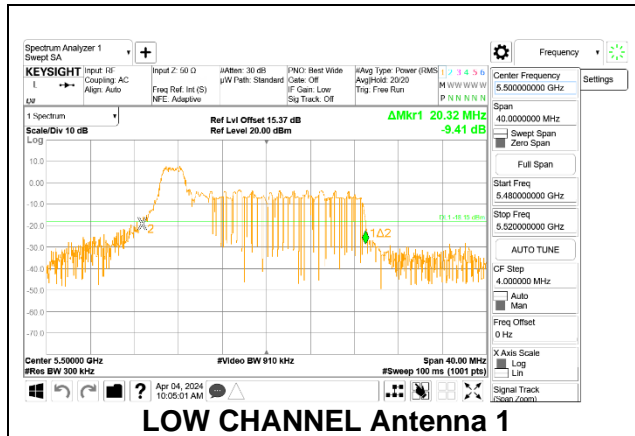

LOW CHANNEL Antenna 1

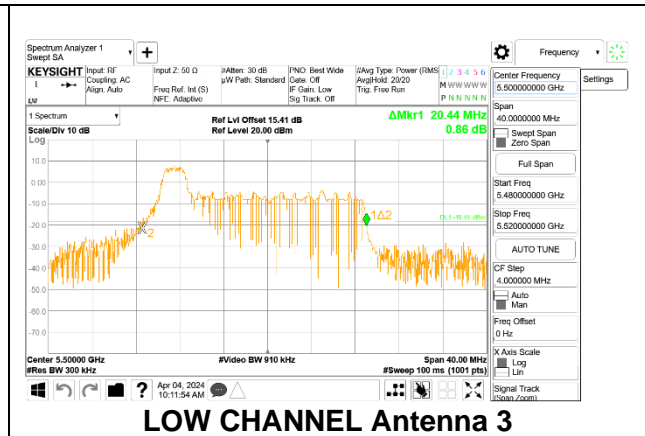

LOW CHANNEL Antenna 3