

TEST REPORT

Report Number : R14896020-E8

Applicant : Sonos
301 Coromar Dr
Goleta, CA 93117 USA

MODEL : S45

FCC ID : SBVRM045

IC : 5373A-RM045

EUT Description : Wireless Smart Speaker

Test Standard(s) : FCC 47 CFR Part 15 Subpart E:2024
ISED RSS-248 Issue 2:2022
ISED RSS-GEN Issue 5 +A1+A2:2021

Date Of Issue:

2024-06-03

Prepared by:

UL LLC

12 Laboratory Dr.

Research Triangle Park, NC 27709 U.S.A.

TEL: (919) 549-1400



REPORT REVISION HISTORY

Rev.	Issue Date	Revisions	Revised By
V1	2024-05-02	Initial Issue	B. Kiewra
V2	2024-05-28	Corrected calibration date in Section 7 Editorial revisions.	B. Kiewra
V3	2024-06-03	Revised section 6.2 to state device is LPI client	B. Kiewra

TABLE OF CONTENTS

REPORT REVISION HISTORY	2
1. ATTESTATION OF TEST RESULTS	6
2. TEST RESULT SUMMARY	6
3. TEST METHODOLOGY	7
4. FACILITIES AND ACCREDITATION	7
5. DECISION RULES AND MEASUREMENT UNCERTAINTY	8
5.1. METROLOGICAL TRACEABILITY	8
5.2. DECISION RULES.....	8
5.3. MEASUREMENT UNCERTAINTY.....	8
6. EQUIPMENT UNDER TEST	9
6.1. EUT DESCRIPTION	9
6.2. EUT DEVICE CLASS.....	9
6.3. MAXIMUM OUTPUT POWER.....	9
6.4. DESCRIPTION OF AVAILABLE ANTENNAS	11
6.5. SOFTWARE AND FIRMWARE.....	11
6.6. WORST-CASE CONFIGURATION AND MODE.....	12
6.7. DESCRIPTION OF TEST SETUP.....	13
7. TEST AND MEASUREMENT EQUIPMENT	14
8. MEASUREMENT METHOD.....	17
9. ANTENNA PORT TEST RESULTS	18
9.1. ON TIME AND DUTY CYCLE.....	18
9.2. OUTPUT POWER AND PSD.....	21
9.2.1. 802.11a MODE 2TX IN THE U-NII 5 BAND	22
9.2.2. 802.11ax HE20 MODE 2TX IN THE U-NII 5 BAND.....	23
9.2.3. 802.11ax HE40 MODE 2TX IN THE U-NII 5 BAND.....	28
9.2.4. 802.11ax HE80 MODE 2TX IN THE U-NII 5 BAND.....	30
9.2.5. 802.11a MODE 2TX IN THE U-NII 6 BAND	32
9.2.6. 802.11ax HE20 MODE 2TX IN THE U-NII 6 BAND.....	33
9.2.7. 802.11ax HE40 MODE 2TX IN THE U-NII 6 BAND.....	38
9.2.8. 802.11ax HE80 MODE 2TX IN THE U-NII 6 BAND.....	40
9.2.9. 802.11a MODE 2TX IN THE U-NII 7 BAND	42
9.2.10. 802.11ax HE20 MODE 2TX IN THE U-NII 7 BAND	43
9.2.11. 802.11ax HE40 MODE 2TX IN THE U-NII 7 BAND	48
9.2.12. 802.11ax HE80 MODE 2TX IN THE U-NII 7 BAND	50
9.2.13. 802.11a MODE 2TX IN THE U-NII 8 BAND.....	52
9.2.14. 802.11ax HE20 MODE 2TX IN THE U-NII 8 BAND	53

9.2.15.	802.11ax HE40 MODE 2TX IN THE U-NII 8 BAND	58
9.2.16.	802.11ax HE80 MODE 2TX IN THE U-NII 8 BAND	60
9.3.	<i>26 dB BANDWIDTH</i>	63
9.3.1.	802.11a MODE 2TX IN THE UNII-5 BAND	63
9.3.2.	802.11ax HE20 MODE 2TX IN THE UNII-5 BAND	64
9.3.3.	802.11ax HE40 MODE 2TX IN THE UNII-5 BAND	69
9.3.4.	802.11ax HE80 MODE 2TX IN THE UNII-5 BAND	71
9.3.5.	802.11a MODE 2TX IN THE UNII-6 BAND	73
9.3.6.	802.11ax HE20 MODE 2TX IN THE UNII-6 BAND	74
9.3.7.	802.11ax HE40 MODE 2TX IN THE UNII-6 BAND	79
9.3.8.	802.11ax HE80 MODE 2TX IN THE UNII-6 BAND	81
9.3.9.	802.11a MODE 2TX IN THE UNII-7 BAND	83
9.3.10.	802.11ax HE20 MODE 2TX IN THE UNII-7 BAND	84
9.3.11.	802.11ax HE40 MODE 2TX IN THE UNII-7 BAND	89
9.3.12.	802.11ax HE80 MODE 2TX IN THE UNII-7 BAND	91
9.3.13.	802.11a MODE 2TX IN THE UNII-8 BAND.....	93
9.3.14.	802.11ax HE20 MODE 2TX IN THE UNII-8 BAND	94
9.3.15.	802.11ax HE40 MODE 2TX IN THE UNII-8 BAND	99
9.3.16.	802.11ax HE80 MODE 2TX IN THE UNII-8 BAND	101
9.4.	<i>99% BANDWIDTH</i>	103
9.4.1.	802.11a MODE 2TX IN THE UNII-5 BAND	103
9.4.2.	802.11ax HE20 MODE 2TX IN THE UNII-5 BAND	104
9.4.3.	802.11ax HE40 MODE 2TX IN THE UNII-5 BAND	109
9.4.4.	802.11ax HE80 MODE 2TX IN THE UNII-5 BAND	111
9.4.5.	802.11a MODE 2TX IN THE UNII-6 BAND	113
9.4.6.	802.11ax HE20 MODE 2TX IN THE UNII-6 BAND	114
9.4.7.	802.11ax HE40 MODE 2TX IN THE UNII-6 BAND	119
9.4.8.	802.11ax HE80 MODE 2TX IN THE UNII-6 BAND	121
9.4.9.	802.11a MODE 2TX IN THE UNII-7 BAND	123
9.4.10.	802.11ax HE20 MODE 2TX IN THE UNII-7 BAND	124
9.4.11.	802.11ax HE40 MODE 2TX IN THE UNII-7 BAND	129
9.4.12.	802.11ax HE80 MODE 2TX IN THE UNII-7 BAND	131
9.4.13.	802.11a MODE 2TX IN THE UNII-8 BAND.....	133
9.4.14.	802.11ax HE20 MODE 2TX IN THE UNII-8 BAND	134
9.4.15.	802.11ax HE40 MODE 2TX IN THE UNII-8 BAND	139
9.4.16.	802.11ax HE80 MODE 2TX IN THE UNII-8 BAND	141
9.5.	<i>SPURIOUS EMISSIONS IN-BAND – EMISSION MASK</i>	143
9.5.1.	802.11a MODE 2TX IN THE UNII-5 BAND	144
9.5.2.	802.11ax HE20 MODE 2TX IN THE UNII-5 BAND	145
9.5.3.	802.11ax HE40 MODE 2TX IN THE UNII-5 BAND	150
9.5.4.	802.11ax HE80 MODE 2TX IN THE UNII-5 BAND	152
9.5.5.	02.11a MODE 2TX IN THE UNII-6 BAND	154
9.5.6.	802.11ax HE20 MODE 2TX IN THE UNII-6 BAND	155
9.5.7.	802.11ax HE40 MODE 2TX IN THE UNII-6 BAND	160
9.5.8.	802.11ax HE80 MODE 2TX IN THE UNII-6 BAND	162
9.5.9.	802.11a MODE 2TX IN THE UNII-7 BAND	164
9.5.10.	802.11ax HE20 MODE 2TX IN THE UNII-7 BAND	165
9.5.11.	802.11ax HE40 MODE 2TX IN THE UNII-7 BAND	170
9.5.12.	802.11ax HE80 MODE 2TX IN THE UNII-7 BAND	172
9.5.13.	802.11a MODE 2TX IN THE UNII-8 BAND.....	174
9.5.14.	802.11ax HE20 MODE 2TX IN THE UNII-8 BAND	175

9.5.15. 802.11ax HE40 MODE 2TX IN THE UNII-8 BAND 180
9.5.16. 802.11ax HE80 MODE 2TX IN THE UNII-8 BAND 182

10. RADIATED TEST RESULTS 184

10.1. *TRANSMITTER OUTSIDE 5.925-7.125 GHz , 1-18GHz* 186

10.1.1. TX ABOVE 1 GHz 802.11a MODE IN THE UNII-5 BAND 186
10.1.2. TX ABOVE 1 GHz 802.11ax HE20 MODE IN THE UNII-5 BAND 194
10.1.3. TX ABOVE 1 GHz 802.11ax HE40 MODE IN THE UNII-5 BAND 204
10.1.4. TX ABOVE 1 GHz 802.11ax HE80 MODE IN THE UNII-5 BAND 208
10.1.5. TX ABOVE 1 GHz 802.11ax HE20 MODE IN THE UNII-6 BAND 218
10.1.6. TX ABOVE 1 GHz 802.11ax HE80 MODE IN THE UNII-6 BAND 224
10.1.7. TX ABOVE 1 GHz 802.11ax HE20 MODE IN THE UNII-7 BAND 228
10.1.8. TX ABOVE 1 GHz 802.11ax HE80 MODE IN THE UNII-7 BAND 234
10.1.9. TX ABOVE 1 GHz 802.11a MODE IN THE UNII-8 BAND 240
10.1.10. TX ABOVE 1 GHz 802.11ax HE20 MODE IN THE UNII-8 BAND 242
10.1.11. TX ABOVE 1 GHz 802.11ax HE40 MODE IN THE UNII-8 BAND 268
10.1.12. TX ABOVE 1 GHz 802.11ax HE80 MODE IN THE UNII-8 BAND 272

10.2. *WORST CASE BELOW 30MHZ* 282

10.2.1. SPURIOUS EMISSIONS BELOW 30 MHz (E-FIELD) 282
10.2.2. SPURIOUS EMISSIONS BELOW 30 MHz (H-FIELD) 283

10.3. *WORST CASE BELOW 1 GHZ* 284

10.4. *WORST CASE 18-26.5 GHZ* 286

10.5. *WORST CASE 26.5-40 GHZ* 288

11. AC POWER LINE CONDUCTED EMISSIONS 290

11.1. *AC POWER LINE NORM* 291

12. SETUP PHOTOS 293

END OF TEST REPORT 293

1. ATTESTATION OF TEST RESULTS

COMPANY NAME: Sonos
301 Coromar Dr
Goleta, CA 93117 USA

EUT DESCRIPTION: Wireless Smart Speaker

MODEL: S45

BRAND: Sonos

SERIAL NUMBER: 000E5828D66C8, 000E58E7E7FB2, 000E58A36F038

SAMPLE RECEIPT DATE: 2024-02-20

DATE TESTED: 2024-02-22 to 2024-04-30

APPLICABLE STANDARDS	
STANDARD	TEST RESULTS
47 CFR Part 15 Subpart E	Refer to section 2
ISED RSS-248 Issue 2	Refer to section 2
ISED RSS-GEN Issue 5+A1+A2	Refer to section 2

UL LLC tested the above equipment in accordance with the requirements set forth in the above standards. The test results show that the equipment tested is capable of demonstrating compliance with the requirements as documented in this report.

The results documented in this report apply only to the tested sample, under the conditions and modes of operation as described herein. It is the manufacturer's responsibility to assure that additional production units of this model are manufactured with identical electrical and mechanical components. All samples tested were in good operating condition throughout the entire test program. Measurement Uncertainties are published for informational purposes only and were not taken into account unless noted otherwise.

This document may not be altered or revised in any way unless done so by UL LLC and all revisions are duly noted in the revisions section. Any alteration of this document not carried out by UL LLC will constitute fraud and shall nullify the document.

Approved & Released
For UL LLC By:

Prepared By:



Michael Antola
Staff Engineer
Consumer, Medical and IT Segment
UL LLC

Brian Kiewra
Project Engineer
Consumer, Medical and IT Segment
UL LLC

2. TEST RESULT SUMMARY

FCC Clause	ISED Clause	Requirement	Result	Comment
See Comment		Duty Cycle	Reporting purposes only	ANSI C63.10 Section 12.2
See Comment	RSS-248 4.4	99% BW	Compliant	Non
§15.407 (a) (11)	NA	26dB BW	Compliant	None
§15.407 (a) (8)	RSS-248 4.5.3	Output Power e.i.r.p.	Compliant	Low Power Indoor Client.
§15.407 (a) (8)	RSS-248 4.5.3	Power Spectral Density	Compliant	Low Power Indoor Client.
§15.407 (b) (6)	RSS-248 4.6.2 (a)	Emissions outside 5.925-7.125 GHz band	Compliant	None
§15.407 (b) (5)	RSS-248 4.6.2 (b)	Emissions within 5.925-7.125 GHz Band(Emissions Mask)	Compliant	None
§15.407 (d) (6)	RSS-248 4.7	Contention-based protocol	See Comment	Refer to report R14896020-C1
§15.205, §15.209	RSS-GEN 8.9, 8.10	Radiated Spurious Emissions	Compliant	None
§15.207	RSS-Gen 8.8	AC Mains Conducted Emissions	Compliant	None

3. TEST METHODOLOGY

The tests documented in this report were performed in accordance with:

- FCC 47 CFR Part 2
- FCC 47 CFR Part 15
- FCC KDB 662911 D01 v02r01
- FCC KDB 789033 D02 v02r01
- ANSI C63.10-2020
- RSS-GEN Issue 5 + A1/2
- RSS-248 Issue 2
- FCC KDB 987594 D01 v02r02
- FCC KDB 987594 D02 v02r01

4. FACILITIES AND ACCREDITATION

UL LLC is accredited by A2LA, certification # 0751.06, for all testing performed within the scope of this report. Testing was performed at the locations noted below.

	Address	ISED CABID	ISED Company Number	FCC Registration
<input type="checkbox"/>	Building: 12 Laboratory Dr RTP, NC 27709, U.S.A	US0067	2180C	825374
<input checked="" type="checkbox"/>	Building: 2800 Perimeter Park Dr. Suite B Morrisville, NC 27560, U.S.A		27265	

5. DECISION RULES AND MEASUREMENT UNCERTAINTY

5.1. METROLOGICAL TRACEABILITY

All test and measuring equipment utilized to perform the tests documented in this report are calibrated on a regular basis, with a maximum time between calibrations of one year or the manufacturers' recommendation, whichever is less, and where applicable is traceable to recognized national standards.

5.2. DECISION RULES

The Decision Rule is based on Simple Acceptance in accordance with ISO Guide 98-4:2012 Clause 8.2. (Measurement uncertainty is not taken into account when stating conformity with a specified requirement.)

5.3. MEASUREMENT UNCERTAINTY

Where relevant, the following measurement uncertainty levels have been estimated for tests performed on the apparatus:

PARAMETER	U _{Lab}
Radio Frequency (Spectrum Analyzer)	141.2 Hz
Occupied Channel Bandwidth	1.22%
RF output power, conducted	1.3 dB (PK) 0.45 dB (AV)
Power Spectral Density, conducted	2.47 dB
Unwanted Emissions, conducted	1.94 dB
All emissions, radiated	6.01 dB
Mains Conducted Emissions (0.150-30MHz) - LISN	3.40 dB
Temperature	0.57°C
Humidity	3.39%
DC Supply voltages	1.70%

Uncertainty figures are valid to a confidence level of 95%.

RADIATED EMISSIONS

Where relevant, the following sample calculation is provided:

$$\text{Field Strength (dBuV/m)} = \text{Measured Voltage (dBuV)} + \text{Antenna Factor (dB/m)} + \text{Cable Loss (dB)} - \text{Preamp Gain (dB)}$$

$$36.5 \text{ dBuV} + 18.7 \text{ dB/m} + 0.6 \text{ dB} - 26.9 \text{ dB} = 28.9 \text{ dBuV/m}$$

MAINS CONDUCTED EMISSIONS

Where relevant, the following sample calculation is provided:

$$\text{Final Voltage (dBuV)} = \text{Measured Voltage (dBuV)} + \text{Cable Loss (dB)} + \text{Limiter Factor (dB)} + \text{LISN Insertion Loss}$$

$$36.5 \text{ dBuV} + 0 \text{ dB} + 10.1 \text{ dB} + 0 \text{ dB} = 46.6 \text{ dBuV}$$

OUTPUT POWER (EIRP)

Conducted Power + Ant Gain = EIRP:

6. EQUIPMENT UNDER TEST

6.1. EUT DESCRIPTION

The EUT is a Wireless Smart Speaker that contains Radio0 and Radio1. Radio0 transmits BT, BLE, 2.4GHz WLAN, 5GHz WLAN, 6GHz WLAN. Radio1 transmits 5GHz and 6GHz WLAN. This report covers testing on Radio0 6GHz.

6.2. EUT DEVICE CLASS

EUT is of the following device class:

	U-NII Bands of Operation			
	5	6	7	8
LPI Client (6XD)	☒	☒	☒	☒

6.3. MAXIMUM OUTPUT POWER

The transmitter has a maximum e.i.r.p. output power as follows:

U-NII 5 (5.925-6.425 GHz) BAND

Frequency Range (MHz)	Mode	e.i.r.p. Power (dBm)	Output Power (mW)
LPI			
5955-6415	802.11a	6.90	4.90
	802.11ax HE20 OFDMA, 26T	-0.57	0.88
	802.11ax HE20 OFDMA, 52T	0.07	1.02
	802.11ax HE20 OFDMA, 106T	4.04	2.54
	802.11ax HE20 OFDMA, 242T	6.82	4.81
	802.11ax HE20 OFDMA, SU	7.09	5.12
5965-6405	802.11ax HE40 OFDMA, 484T	8.79	7.57
5965-6405	802.11ax HE40 OFDMA, SU	8.89	7.74
5985-6385	802.11ax HE80 OFDMA, 996T	11.85	15.31
5985-6385	802.11ax HE80 OFDMA, SU	12.39	17.34

U-NII-6 (6.425-6.525 GHz) BAND

Frequency Range (MHz)	Mode	e.i.r.p. Power (dBm)	Output Power (mW)
LPI			
6435-6515	802.11a	7.11	5.14
	802.11ax HE20 OFDMA, 26T	-0.13	0.97
	802.11ax HE20 OFDMA, 52T	0.78	1.20
	802.11ax HE20 OFDMA, 106T	4.21	2.64
	802.11ax HE20 OFDMA, 242T	7.11	5.14
	802.11ax HE20 OFDMA, SU	7.50	5.62
6445-6485	802.11ax HE40 OFDMA, 484T	9.50	8.91
	802.11ax HE40 OFDMA, SU	10.33	10.79
6465-6545	802.11ax HE80 OFDMA, 996T	12.07	16.11
	802.11ax HE80 OFDMA, SU	13.15	20.65

U-NII-7 (6.525-6.875 GHz) BAND

Frequency Range (MHz)	Mode	e.i.r.p. Power (dBm)	Output Power (mW)
LPI			
6535-6855	802.11a	7.04	5.06
	802.11ax HE20 OFDMA, 26T	-0.06	0.99
	802.11ax HE20 OFDMA, 52T	0.56	1.14
	802.11ax HE20 OFDMA, 106T	3.61	2.30
	802.11ax HE20 OFDMA, 242T	7.92	6.19
	802.11ax HE20 OFDMA, SU	7.68	5.86
6565-6845	802.11ax HE40 OFDMA, 484T	8.93	7.82
	802.11ax HE40 OFDMA, SU	9.91	9.79
6625-6785	802.11ax HE80 OFDMA, 996T	12.24	16.75
	802.11ax HE80 OFDMA, SU	12.17	16.48

U-NII 8 (6.875-7.125 GHz) BAND

Frequency Range (MHz)	Mode	e.i.r.p. Power (dBm)	Output Power (mW)
LPI			
6875-7115	802.11a	7.27	5.33
	802.11ax HE20 OFDMA, 26T	0.04	1.01
	802.11ax HE20 OFDMA, 52T	1.11	1.29
	802.11ax HE20 OFDMA, 106T	4.66	2.92
	802.11ax HE20 OFDMA, 242T	7.39	5.48
	802.11ax HE20 OFDMA, SU	7.95	6.24
6885-7085	802.11ax HE40 OFDMA, 484T	9.73	9.40
	802.11ax HE40 OFDMA, SU	10.08	10.19
6865-7025	802.11ax HE80 OFDMA, 996T	12.75	18.84
	802.11ax HE80 OFDMA, SU	12.89	19.45

6.4. DESCRIPTION OF AVAILABLE ANTENNAS

The radio utilizes 4 antennas for diversity, chain 0 connects ANT 1 and ANT2, chain 1 connects to ANT3 and ANT 4. Through pretesting it was determined that antenna 2 and antenna 3 are worst-case combination and result in worst-case antenna gains as declared below.

Type	UNII Band	Correlated Gain (dBi)	Uncorrelated Gain (dBi)
Triband Monopole	UNII 5	7.3	4.5
	UNII 6	7.2	4.4
	UNII 7	7.2	4.5
	UNII 8	6.4	3.9

6.5. SOFTWARE AND FIRMWARE

The EUT firmware installed during testing was 78.1-45200-diag-lasso-rel-202312282317.

6.6. WORST-CASE CONFIGURATION AND MODE

Radiated emissions below 1GHz, above 18GHz, and power line conducted emission were performed with the EUT set to transmit at the channel with highest output power as worst-case scenario. These scans were chosen and run based on higher power measurements than reported.

For all modes, tests were performed with the EUT set at the 2Tx MIMO mode with power setting equal to SISO modes as the worst-case scenario thus MIMO is representative of SISO.

Radiated emissions between 1GHz and 18GHz were performed with the EUT set to transmit at the highest power on low and high channels on all modes for bandedge and low, middle and high channels on modes with worst-case power/PSD for harmonics and spurious.

The EUT is intended to operate in only one orientation, therefore, all final radiated testing was performed with the EUT in this intended orientation of operation.

All testing performed in 2Tx mode (NSS=1), where power per chain is equivalent to the 1Tx power on each chain. Based on preliminary testing, this allows 2Tx testing to cover all 1Tx testing.

Worst-case data rates as provided by the client were:

802.11a mode: 6 Mbps

802.11ax HE20mode: MCS0 (Nss = 1)

802.11ax HE40mode: MCS0 (Nss = 1)

802.11ax HE80mode: MCS0 (Nss = 1)

Notes: Only representative plots included for PSD and BW measurements.

PSD not stepped as it was taken at a higher power than the stepped power.

6.7. DESCRIPTION OF TEST SETUP

SUPPORT EQUIPMENT

Support Equipment List				
Description	Manufacturer	Model	Serial Number	FCC ID
Laptop	Lenovo	T450s	NA	NA
Laptop	Lenovo	T470s	NA	NA
Ethernet Switch	Netgear	GS305v3	5U81385JA2EE6	NA
Switch PSU	Netgear	AD2015F20	332-10727-02	NA

I/O CABLES

I/O Cable List						
Cable No.	Port	# of Identical Ports	Connector Type	Cable Type	Cable Length (m)	Remarks
1	Mains	1	Hardwired	Non-Shielded	>3m	Connects to AC Mains
2	Ethernet	1	Ethernet	Non-Shielded	>3m	Connects to ENET switch

TEST SETUP

The EUT is connected to a test laptop during the tests.

SETUP DIAGRAMS

Please refer to R14896020-EP1 for setup diagrams

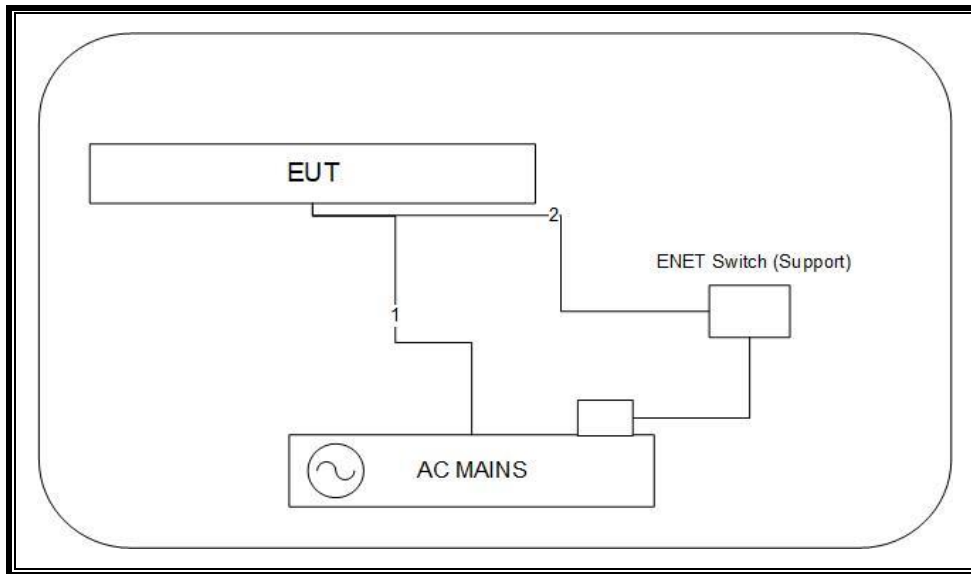

7. TEST AND MEASUREMENT EQUIPMENT

The following test and measurement equipment was utilized for the tests documented in this report:

Test Equipment Used - Radiated Disturbance Emissions Test Equipment (Morrisville – Chamber 4)

Equipment ID	Description	Manufacturer/Brand	Model Number	Last Cal.	Next Cal.
0.009-30MHz					
135144	Active Loop Antenna	ETS-Lindgren	6502	2024-01-24	2025-01-24
30-1000 MHz					
90628	Hybrid Broadband Antenna	Sunol Sciences Corp.	JB3	2024-01-02	2026-01-02
1-18 GHz					
89509	Double-Ridged Waveguide Horn Antenna, 1 to 18 GHz	ETS Lindgren	3117	2023-05-23	2025-05-23
18-40 GHz					
204704	Horn Antenna, 18-26.5GHz	Com-Power	AH-826	2023-07-20	2025-07-20
204705	Horn Antenna, 26-40GHz	Com-Power	AH-640	2023-07-20	2025-07-20
Gain-Loss Chains					
207638	Gain-loss string: 0.009-30MHz	Various	Various	2023-09-18	2024-09-18
207639	Gain-loss string: 25-1000MHz	Various	Various	2023-09-18	2024-09-18
207640	Gain-loss string: 1-18GHz	Various	Various	2023-05-17	2024-05-17
225795	Gain-loss string: 18-40GHz	Various	Various	2023-05-17	2024-05-17
Receiver & Software					
197955	Spectrum Analyzer	Rohde & Schwarz	ESW44	2023-04-10	2024-04-10
81018	Spectrum Analyzer	Agilent	E4446A	2023-08-01	2024-08-01
SOFTEMI	EMI Software	UL	Version 9.5 (18 Oct 2021)		
Additional Equipment used					
241204	Environmental Meter	Fisher Scientific	15-077-963	2023-09-05	2025-09-05
216159 (HPF019)	7GHz high-pass filter, 2W, Fhigh =18GHz	Micro-Tronics	HPM50107	2023-02-15	2024-02-29

Note: All equipment within calibration at time of use.

Test Equipment Used - Radiated Disturbance Emissions Test Equipment (Morrisville – Chamber 2)

Equipment ID	Description	Manufacturer/Brand	Model Number	Last Cal.	Next Cal.
1-18 GHz					
86408	Double-Ridged Waveguide Horn Antenna, 1 to 18 GHz	ETS Lindgren	3117	2023-06-19	2025-06-19
Gain-Loss Chains					
91977	Gain-loss string: 1-18GHz	Various	Various	2023-06-06	2024-06-06
Receiver & Software					
197954	Spectrum Analyzer	Rohde & Schwarz	ESW44	2024-04-16	2025-04-16
SOFTEMI	EMI Software	UL	Version 9.5 (18 Oct 2021)		
Additional Equipment used					
200540	Environmental Meter	Fisher Scientific	15-077-963	2023-07-19	2025-07-19
35879	10dB Pad, DC-18GHz, 5W	Mini-Circuits	BW-N10W5+	2023-11-09	2024-11-09

Test Equipment Used - Line-Conducted Emissions – Voltage (Morrisville – Conducted 1)

Equipment ID	Description	Manufacturer	Model Number	Last Cal.	Next Cal.
CBL087	Coax cable, RG223, N-male to BNC-male, 20-ft.	Pasternack	PE3W06143-240	2024-04-04	2025-04-04
179892	Environmental Meter	Fisher Scientific	15-077-963	2023-07-26	2024-06-31
80391	LISN, 50-ohm/50-uH, 250uH 2-conductor, 25A	Fischer Custom Com.	FCC-LISN-50/250-25-2-01	2023-07-31	2024-07-31
75141	EMI Test Receiver 9kHz-7GHz	Rohde & Schwarz	ESCI 7	2023-08-01	2024-08-01
52859	Transient Limiter, 0.009-100MHz	Electro-Metrics	EM-7600	2024-04-04	2025-04-04
PS215	AC Power Source	Elgar	CW2501M	NA	NA
SOFTEMI	EMI Software	UL	Version 9.5 (18 Oct 2021)		
91432	LISN, 50-ohm/50-uH, 2-conductor, 25A (For support gear only.)	Solar Electronics	8012-50-R-24-BNC	NA	NA

Test Equipment Used - Wireless Conducted Measurement Equipment

Equipment ID	Description	Manufacturer	Model Number	Last Cal.	Next Cal.
90410	Spectrum Analyzer	Keysight Technologies	N9030A	2023-06-14	2024-06-14
90416	Spectrum Analyzer	Keysight Technologies	N9030A	2023-06-09	2024-06-30
238710	Environmental Meter	Fisher Scientific	15-077-963	2023-07-26	2024-07-31
211056	Real-Time Peak Power Sensor 50MHz to 8GHz	Boonton	RTP5000	2023-08-01	2024-08-01
211055	Real-Time Peak Power Sensor 50MHz to 8GHz	Boonton	RTP5000	2023-08-01	2024-08-01
211057	Real-Time Peak Power Sensor 50MHz to 8GHz	Boonton	RTP5000	2023-08-01	2024-08-01
211058	Real-Time Peak Power Sensor 50MHz to 8GHz	Boonton	RTP5000	2023-08-01	2024-08-01
Power Software	Boonton Power Analyzer	Boonton	Version 3.0.13.0	NA	NA
SOFTEMI	Antenna Port Software	UL	Version 2021.5.28	NA	NA
SOFTEMI	Antenna Port Software	UL	Version 2022.8.16	NA	NA
SOFTEMI	Antenna Port Software	UL	Version 2023.2.16	NA	NA
SOFTEMI	Antenna Port Software	UL	Version 2024.2.23	NA	NA
245262	Conducted Switch Box	UL	CSB	2024-02-20	2025-02-20
Additional Equipment used					
226563	SMA Coaxial 10dB Attenuator 25MHz-18GHz	CentricRF	C18S2-10	2024-02-29	2025-02-29
226551	SMA Coaxial 20dB Attenuator 25MHz-18GHz	CentricRF	C18S2-20	2024-02-29	2025-02-29
CBL031	SMA Male to SMA Male Cable Using PE-P141 Coax - 12"	Pasternack	Sucoflex 104PEA	2023-06-27	2024-06-27
CBL030	SMA Male to SMA Male Cable Using PE-P141 Coax - 12"	Pasternack	Sucoflex 104PEA	2023-06-27	2024-06-27

8. MEASUREMENT METHOD

On Time and Duty Cycle: KDB 789033 D02 v02r01, Section B.

26 dB Emission BW: KDB 789033 D02 v02r01, Section C.1

99% BW: KDB 789033 D02 v02r01, Section D

Conducted Output Power: KDB 789033 D02 v02r01, Section II E.3.b (Method PM-G).

Power Spectral Density (PSD): KDB 789033 D02 v02r01, Section F

Spurious emissions within 5.925-7.125 GHz Band (Emissions Mask): KDB 987594 D02 EMC Measurement Section II-J

Unwanted emissions in restricted bands: KDB 789033 D02 v02r01, Sections G.3, G.4, G.5, and G.6.

Unwanted emissions in non-restricted bands: KDB 789033 D02 v02r01, Sections G.3, G.4, and G.5.

AC Power Line Conducted Emissions: ANSI C63.10-2020, Section 6.2.

Radiated Spurious Emissions Below 30MHz: ANSI C63.10-2020 Section 6.4

9. ANTENNA PORT TEST RESULTS

9.1. ON TIME AND DUTY CYCLE

LIMITS

None; for reporting purposes only.

TEST PROCEDURE

KDB 789033 Zero-Span Spectrum Analyzer Method.

Mode	ON Time B (msec)	Period (msec)	Duty Cycle x (linear)	Duty Cycle (%)	Voltage AV Duty Cycle Correction Factor (dB)	RMS AV Duty Cycle Correction Factor (dB)
802.11a CDD	2.755	3.420	0.806	80.56	1.88	0.94
802.11ax HE20 26T	0.578	1.182	0.489	48.86	6.22	3.11
802.11ax HE20 52T	0.496	1.098	0.451	45.13	6.91	3.46
802.11ax HE20 106T	0.436	1.038	0.420	41.98	7.54	3.77
802.11ax HE20 242T	0.376	0.978	0.384	38.44	8.30	4.15
802.11ax HE20 SU	4.098	4.854	0.844	84.43	1.47	0.74
802.11ax HE40 484T	0.368	0.979	0.376	37.58	8.50	4.25
802.11ax HE40 SU	2.077	2.816	0.738	73.76	2.64	1.32
802.11ax HE80 996T	0.344	0.973	0.353	35.33	9.04	4.52
802.11ax HE80 SU	1.025	1.771	0.579	57.88	4.75	2.37

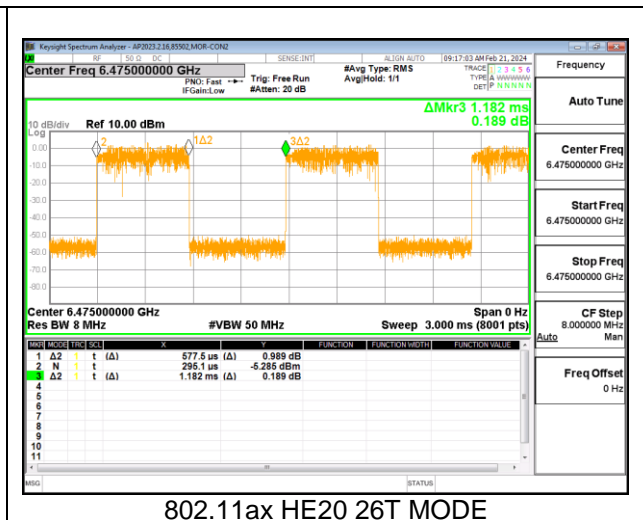
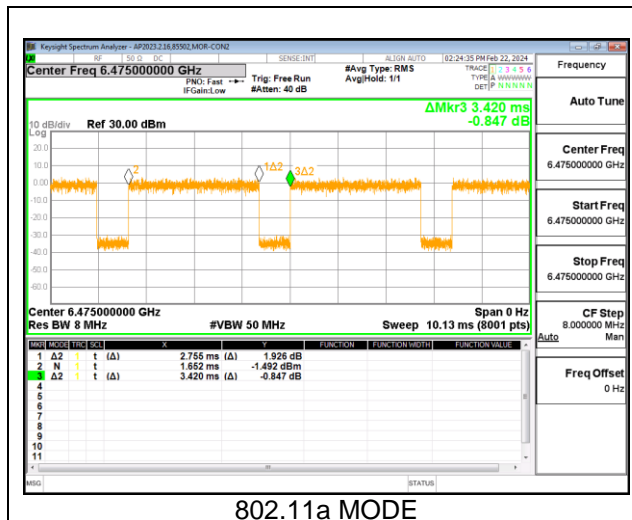



802.11ax HE20 52T MODE



802.11ax HE20 106T MODE

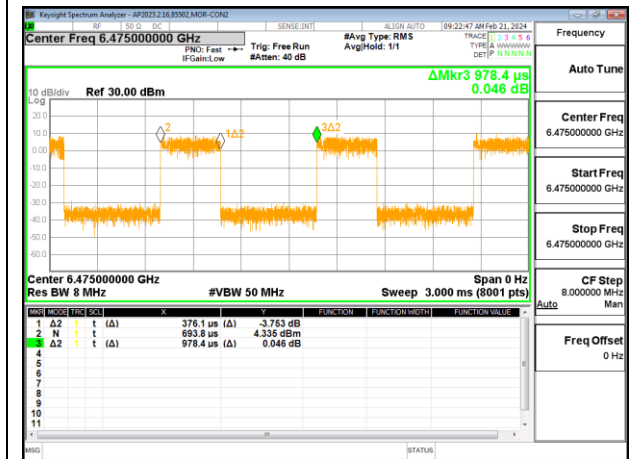

802.11ax HE20 242T MODE



802.11ax HE20 SU MODE



802.11ax HE40 484T MODE

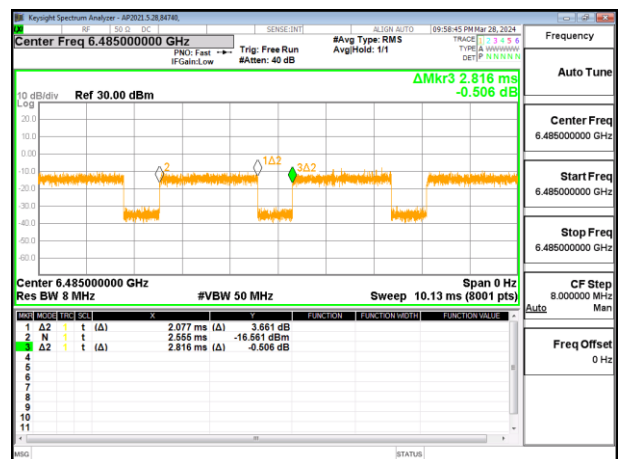

802.11ax HE40 SU MODE

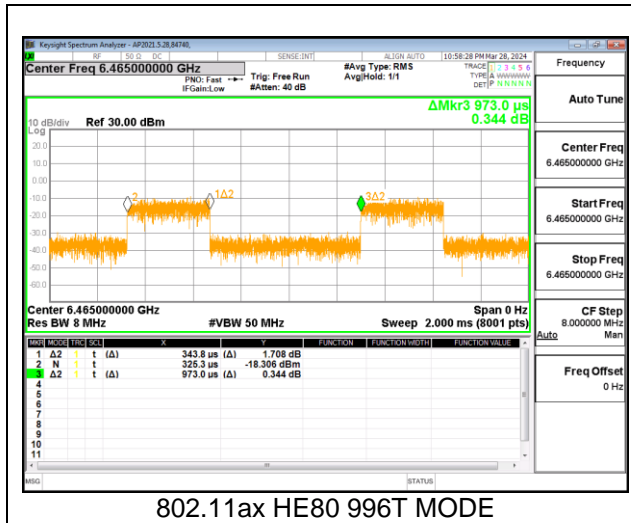

802.11ax HE80 996T MODE

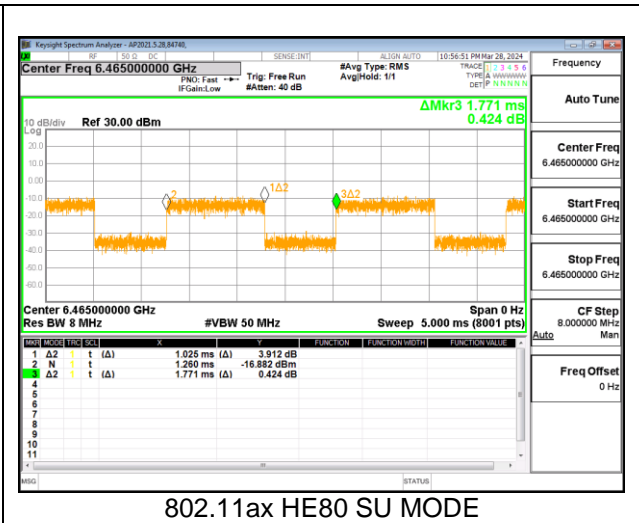

802.11ax HE80 SU MODE

9.2. OUTPUT POWER AND PSD

LIMITS

FCC §15.407 (a)

Band 5.925-7.125 GHz

(8) For client devices operating under the control of an indoor access point in the 5.925-7.125 GHz bands, the maximum power spectral density must not exceed -1 dBm e.i.r.p. in any 1-megahertz band, and the maximum e.i.r.p. over the frequency band of operation must not exceed 24 dBm.

RSS-248

4.5.3 Power limits for low-power client devices

The following limits shall apply to low-power client devices:

- a. the maximum e.i.r.p. spectral density shall not exceed -1 dBm/MHz and
- b. the maximum e.i.r.p. over the 5925-7125 MHz frequency band shall not exceed 24 dBm

TEST PROCEDURE

The measurement method used for output power is KDB 789033 D02 v02r01, Section E.3.b (Method PM-G)

The measurement method used for power spectral density is KDB 789033 D02 v02r01, Section F

2 TX DIRECTIONAL ANTENNA GAIN

Tx ANTENNAS are uncorrelated for power and correlated for PSD. The directional gains are as follows:

U-NII Band	Uncorrelated Chains Directional Gain (dBi)	Correlated Chains Directional Gain (dBi)
5	4.5	7.3
6	4.4	7.2
7	4.5	7.2
8	3.9	6.4

Note: Directional gains declared as worst-case combinations by manufacturer.

9.2.1. 802.11a MODE 2TX IN THE U-NII 5 BAND

2TX CHAIN 0 + CHAIN 1

Test Engineer:	85502
Test Date:	2024/02/22

Bandwidth, Antenna Gain and Limits

Channel	Frequency (MHz)	Directional Gain for Power (dBi)	Directional Gain for PSD (dBi)	e.i.r.p. Power Limit (dBm)	PSD Limit (dBm)
Low	5955	4.50	7.30	24.00	-1.00
Mid	6175	4.50	7.30	24.00	-1.00
High	6415	4.50	7.30	24.00	-1.00

Duty Cycle CF (dB)	0.94	Included in Calculations of Corr'd PSD
--------------------	------	--

Output Power Results

Channel	Frequency (MHz)	Chain 0 Meas Power (dBm)	Chain 1 Meas Power (dBm)	Total Corr'd EIRP (dBm)	Power Limit EIRP (dBm)	Power Margin (dB)
Low	5955	-1.30	-0.38	6.69	24.00	-17.31
Mid	6175	-0.77	-0.46	6.90	24.00	-17.10
High	6415	-1.23	-1.25	6.27	24.00	-17.73

PSD Results

Channel	Frequency (MHz)	Chain 0 Meas PSD (dBm)	Chain 1 Meas PSD (dBm)	Total Corr'd PSD (dBm)	PSD EIRP Limit (dBm)	PSD EIRP Margin (dB)
Low	5955	-13.43	-12.16	-1.50	-1.00	-0.50
Mid	6175	-14.17	-12.03	-1.72	-1.00	-0.72
High	6415	-14.68	-11.93	-1.84	-1.00	-0.84

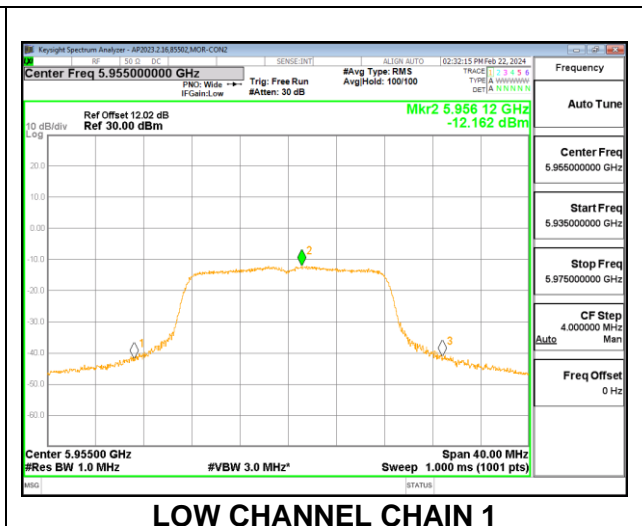
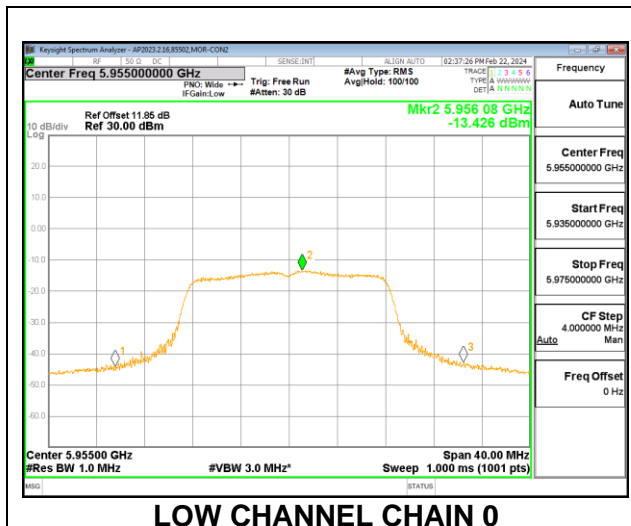

9.2.2. 802.11ax HE20 MODE 2TX IN THE U-NII 5 BAND

2TX CHAIN 0 + CHAIN 1 OFDMA MODE 26T

Test Engineer:	85502
Test Date:	2024/02/21

Bandwidth, Antenna Gain and Limits

Channel	Frequency (MHz)	Directional Gain for Power (dBi)	Directional Gain for PSD (dBi)	e.i.r.p. Power Limit (dBm)	PSD Limit (dBm)
Low	5955	4.50	7.30	24.00	-1.00
Mid	6175	4.50	7.30	24.00	-1.00
High	6415	4.50	7.30	24.00	-1.00

Duty Cycle CF (dB)	3.11	Included in Calculations of Corr'd PSD
--------------------	------	--

Output Power Results

Channel	Frequency (MHz)	Chain 0 Meas Power (dBm)	Chain 1 Meas Power (dBm)	Total Corr'd EIRP (dBm)	Power Limit EIRP (dBm)	Power Margin (dB)
Low	5955	-10.46	-9.30	-2.33	24.00	-26.33
Mid	6175	-8.27	-7.89	-0.57	24.00	-24.57
High	6415	-8.95	-8.69	-1.31	24.00	-25.31

PSD Results

Channel	Frequency (MHz)	Chain 0 Meas PSD (dBm)	Chain 1 Meas PSD (dBm)	Total Corr'd PSD (dBm)	PSD EIRP Limit (dBm)	PSD EIRP Margin (dB)
Low	5955	-16.06	-14.25	-1.64	-1.00	-0.64
Mid	6175	-16.02	-14.48	-1.76	-1.00	-0.76
High	6415	-16.10	-14.31	-1.69	-1.00	-0.69

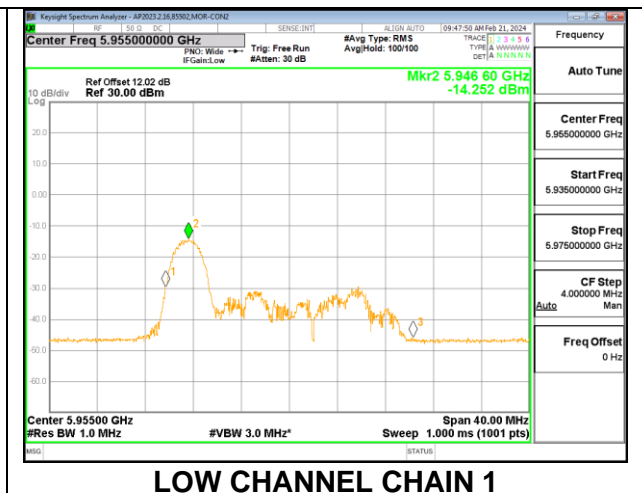
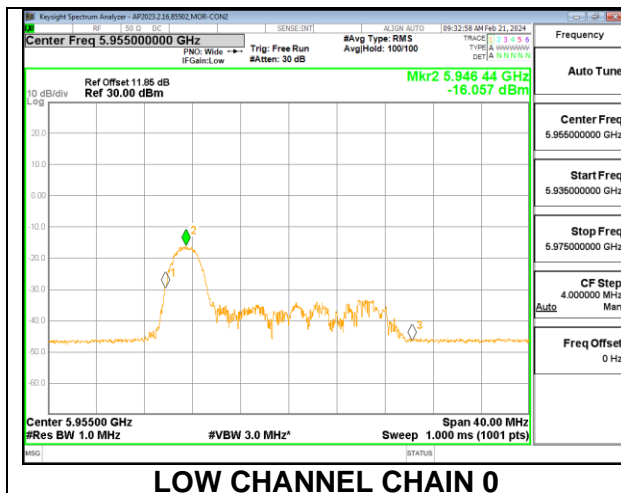

2TX CHAIN 0 + CHAIN 1 OFDMA MODE 52T

Test Engineer:	85502
Test Date:	2024/02/21

Bandwidth, Antenna Gain and Limits

Channel	Frequency (MHz)	Directional Gain for Power (dBi)	Directional Gain for PSD (dBi)	e.i.r.p. Power Limit (dBm)	PSD Limit (dBm)
Low	5955	4.50	7.30	24.00	-1.00
Mid	6175	4.50	7.30	24.00	-1.00
High	6415	4.50	7.30	24.00	-1.00

Duty Cycle CF (dB)	3.46	Included in Calculations of Corr'd PSD
---------------------------	------	---

Output Power Results

Channel	Frequency (MHz)	Chain 0 Meas Power (dBm)	Chain 1 Meas Power (dBm)	Total Corr'd EIRP (dBm)	Power Limit EIRP (dBm)	Power Margin (dB)
Low	5955	-8.77	-7.46	-0.56	24.00	-24.56
Mid	6175	-7.64	-7.25	0.07	24.00	-23.93
High	6415	-7.59	-7.65	-0.11	24.00	-24.11

PSD Results

Channel	Frequency (MHz)	Chain 0 Meas PSD (dBm)	Chain 1 Meas PSD (dBm)	Total Corr'd PSD (dBm)	PSD EIRP Limit (dBm)	PSD EIRP Margin (dB)
Low	5955	-16.31	-14.30	-1.42	-1.00	-0.42
Mid	6175	-15.90	-14.54	-1.40	-1.00	-0.40
High	6415	-16.14	-14.46	-1.45	-1.00	-0.45



2TX CHAIN 0 + CHAIN 1 OFDMA MODE 106T

Test Engineer:	85502
Test Date:	2024/02/21, 2024-04-11

Bandwidth, Antenna Gain and Limits

Channel	Frequency (MHz)	Directional Gain for Power (dBi)	Directional Gain for PSD (dBi)	e.i.r.p. Power Limit (dBm)	PSD Limit (dBm)
Low	5955	4.50	7.30	24.00	-1.00
Mid	6175	4.50	7.30	24.00	-1.00
High	6415	4.50	7.30	24.00	-1.00

Duty Cycle CF (dB)	3.77	Included in Calculations of Corr'd PSD
---------------------------	------	---

Output Power Results

Channel	Frequency (MHz)	Chain 0 Meas Power (dBm)	Chain 1 Meas Power (dBm)	Total Corr'd EIRP (dBm)	Power Limit EIRP (dBm)	Power Margin (dB)
Low	5955	-3.88	-4.26	3.44	24.00	-20.56
Mid	6175	-3.47	-3.28	4.14	24.00	-19.86
High	6415	-4.05	-3.66	3.66	24.00	-20.34

PSD Results

Channel	Frequency (MHz)	Chain 0 Meas PSD (dBm)	Chain 1 Meas PSD (dBm)	Total Corr'd PSD (dBm)	PSD EIRP Limit (dBm)	PSD EIRP Margin (dB)
Low	5955	-16.65	-15.24	-1.80	-1.00	-0.80
Mid	6175	-16.17	-15.41	-1.69	-1.00	-0.69
High	6415	-15.64	-16.19	-1.82	-1.00	-0.82

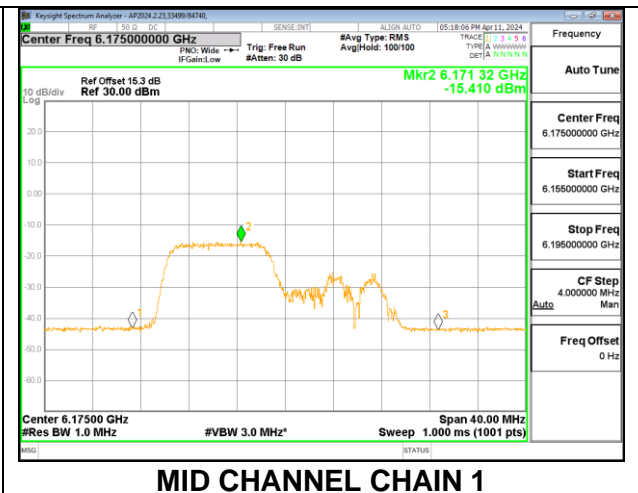
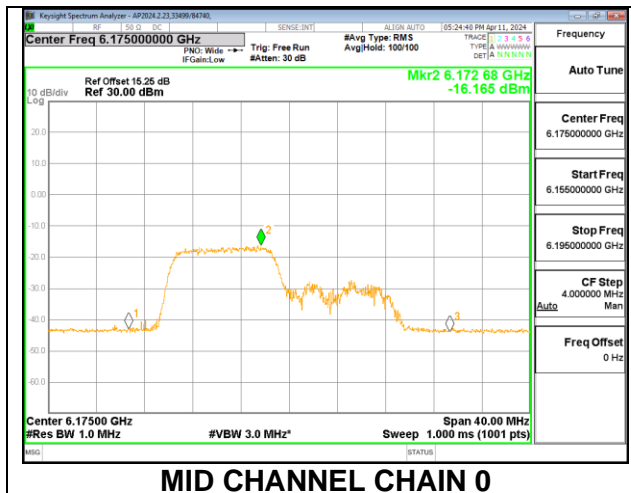

2TX CHAIN 0 + CHAIN 1 OFDMA MODE 242T

Test Engineer:	84740
Test Date:	2024/02/21

Bandwidth, Antenna Gain and Limits

Channel	Frequency (MHz)	Directional Gain for Power (dBi)	Directional Gain for PSD (dBi)	e.i.r.p. Power Limit (dBm)	PSD Limit (dBm)
Low	5955	4.50	7.30	24.00	-1.00
Mid	6175	4.50	7.30	24.00	-1.00
High	6415	4.50	7.30	24.00	-1.00

Duty Cycle CF (dB)	4.15	Included in Calculations of Corr'd PSD
---------------------------	------	---

Output Power Results

Channel	Frequency (MHz)	Chain 0 Meas Power (dBm)	Chain 1 Meas Power (dBm)	Total Corr'd EIRP (dBm)	Power Limit EIRP (dBm)	Power Margin (dB)
Low	5955	-1.67	-1.11	6.13	24.00	-17.87
Mid	6175	-0.76	-0.63	6.82	24.00	-17.18
High	6415	-1.13	-1.35	6.27	24.00	-17.73

PSD Results

Channel	Frequency (MHz)	Chain 0 Meas PSD (dBm)	Chain 1 Meas PSD (dBm)	Total Corr'd PSD (dBm)	PSD EIRP Limit (dBm)	PSD EIRP Margin (dB)
Low	5955	-16.60	-15.78	-1.71	-1.00	-0.71
Mid	6175	-16.64	-15.93	-1.81	-1.00	-0.81
High	6415	-17.06	-15.26	-1.61	-1.00	-0.61

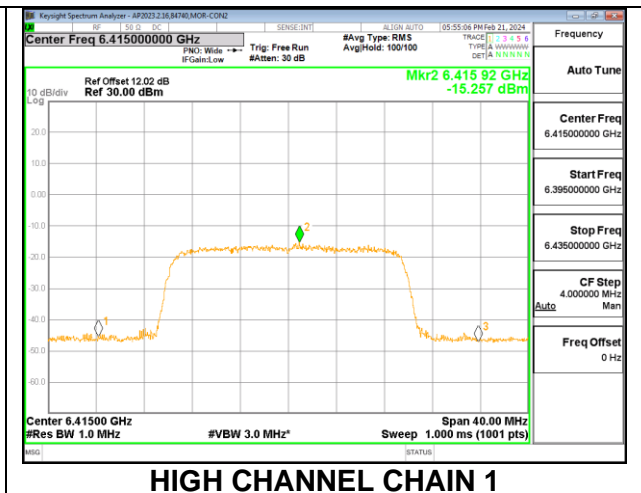
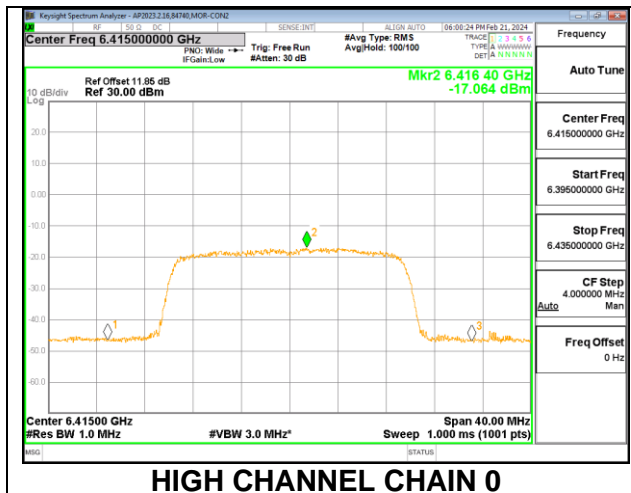

2TX CHAIN 0 + CHAIN 1 OFDMA MODE SU

Test Engineer:	84740
Test Date:	2024/02/21

Bandwidth, Antenna Gain and Limits

Channel	Frequency (MHz)	Directional Gain for Power (dBi)	Directional Gain for PSD (dBi)	e.i.r.p. Power Limit (dBm)	PSD Limit (dBm)
Low	5955	4.50	7.30	24.00	-1.00
Mid	6175	4.50	7.30	24.00	-1.00
High	6415	4.50	7.30	24.00	-1.00

Duty Cycle CF (dB)	0.74	Included in Calculations of Corr'd PSD
---------------------------	------	---

Output Power Results

Channel	Frequency (MHz)	Chain 0 Meas Power (dBm)	Chain 1 Meas Power (dBm)	Total Corr'd EIRP (dBm)	Power Limit EIRP (dBm)	Power Margin (dB)
Low	5955	-1.50	-0.79	6.38	24.00	-17.62
Mid	6175	-0.67	-0.18	7.09	24.00	-16.91
High	6415	-0.98	-1.28	6.38	24.00	-17.62

PSD Results

Channel	Frequency (MHz)	Chain 0 Meas PSD (dBm)	Chain 1 Meas PSD (dBm)	Total Corr'd PSD (dBm)	PSD EIRP Limit (dBm)	PSD EIRP Margin (dB)
Low	5955	-13.25	-11.96	-1.51	-1.00	-0.51
Mid	6175	-13.73	-11.92	-1.68	-1.00	-0.68
High	6415	-13.78	-12.07	-1.79	-1.00	-0.79

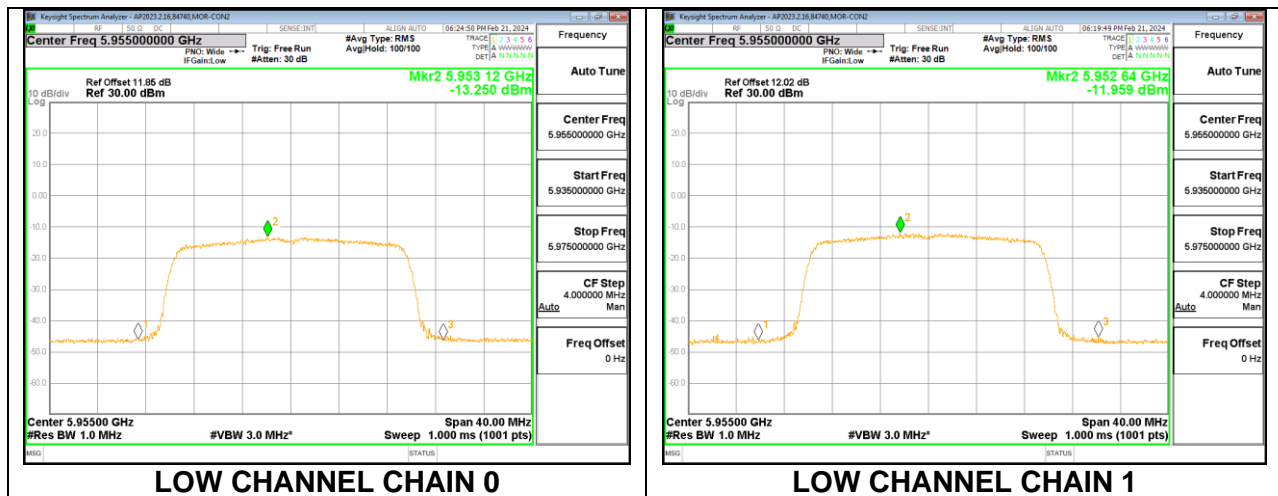

9.2.3. 802.11ax HE40 MODE 2TX IN THE U-NII 5 BAND

2TX CHAIN 0 + CHAIN 1 OFDMA MODE: 484T

Test Engineer:	85502
Test Date:	2024/02/22

Channel	Frequency (MHz)	Directional Gain for Power (dBi)	Directional Gain for PSD (dBi)	e.i.r.p. Power Limit (dBm)	PSD Limit (dBm)
Low	5965	4.50	7.30	24.00	-1.00
Mid	6165	4.50	7.30	24.00	-1.00
High	6405	4.50	7.30	24.00	-1.00

Duty Cycle CF (dB)	4.25	Included in Calculations of Corr'd PSD
---------------------------	------	---

Output Power Results

Channel	Frequency (MHz)	Chain 0 Meas Power (dBm)	Chain 1 Meas Power (dBm)	Total Corr'd EIRP (dBm)	Power Limit EIRP (dBm)	Power Margin (dB)
Low	5965	0.63	1.85	8.79	24.00	-15.21
Mid	6165	0.82	1.43	8.65	24.00	-15.35
High	6405	-0.13	0.58	7.75	24.00	-16.25

PSD Results

Channel	Frequency (MHz)	Chain 0 Meas PSD (dBm)	Chain 1 Meas PSD (dBm)	Total Corr'd PSD (dBm)	PSD EIRP Limit (dBm)	PSD EIRP Margin (dB)
Low	5965	-16.70	-15.69	-1.61	-1.00	-0.61
Mid	6165	-17.22	-15.25	-1.56	-1.00	-0.56
High	6405	-17.29	-15.59	-1.79	-1.00	-0.79

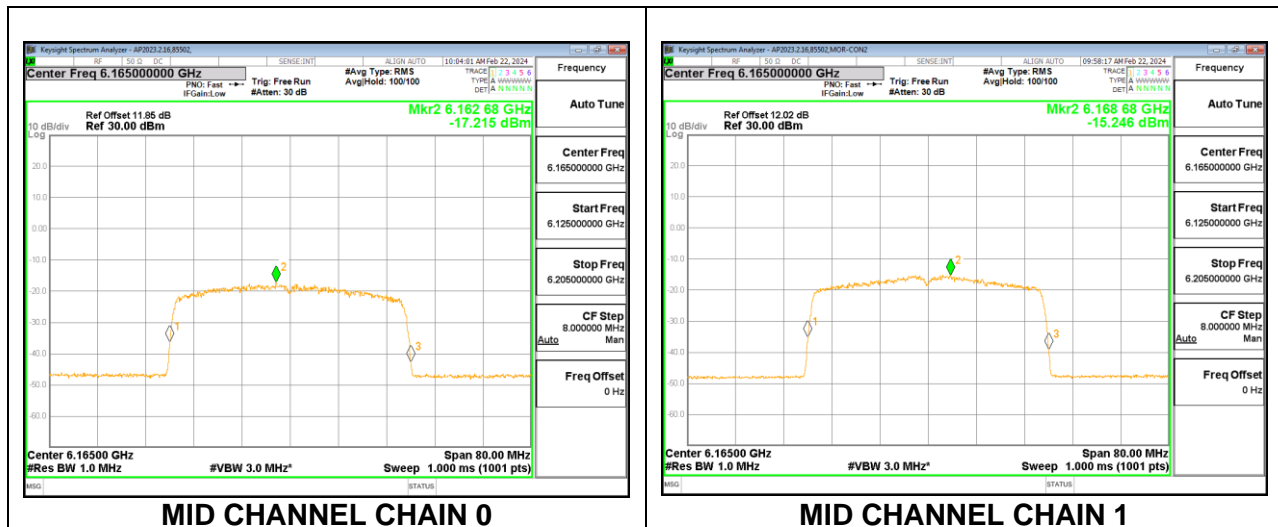

2TX CHAIN 0 + CHAIN 1 OFDMA MODE: SU

Test Engineer:	84740
Test Date:	2024/02/21

Bandwidth, Antenna Gain and Limits

Channel	Frequency (MHz)	Directional Gain for Power (dBi)	Directional Gain for PSD (dBi)	e.i.r.p. Power Limit (dBm)	PSD Limit (dBm)
Low	5965	4.50	7.30	24.00	-1.00
Mid	6165	4.50	7.30	24.00	-1.00
High	6405	4.50	7.30	24.00	-1.00

Duty Cycle CF (dB)	1.32	Included in Calculations of Corr'd PSD
---------------------------	------	---

Output Power Results

Channel	Frequency (MHz)	Chain 0 Meas Power (dBm)	Chain 1 Meas Power (dBm)	Total Corr'd EIRP (dBm)	Power Limit EIRP (dBm)	Power Margin (dB)
Low	5965	0.61	1.69	8.69	24.00	-15.31
Mid	6165	0.70	1.53	8.65	24.00	-15.35
High	6405	1.20	1.55	8.89	24.00	-15.11

PSD Results

Channel	Frequency (MHz)	Chain 0 Meas PSD (dBm)	Chain 1 Meas PSD (dBm)	Total Corr'd PSD (dBm)	PSD EIRP Limit (dBm)	PSD EIRP Margin (dB)
Low	5965	-14.26	-12.79	-1.83	-1.00	-0.83
Mid	6165	-14.64	-12.79	-1.99	-1.00	-0.99
High	6405	-14.80	-12.04	-1.58	-1.00	-0.58

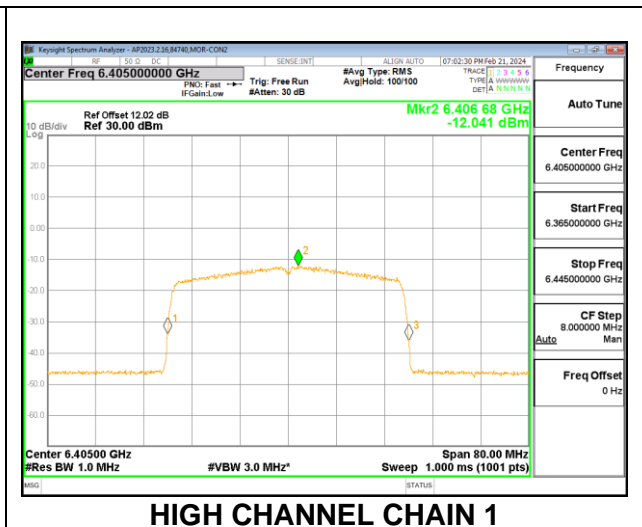
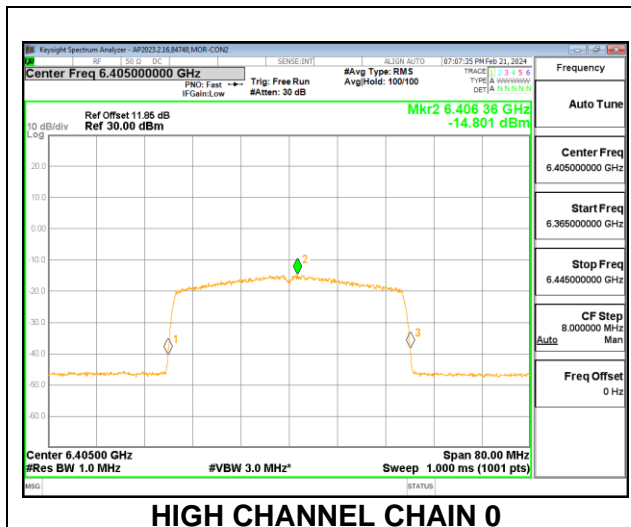

9.2.4. 802.11ax HE80 MODE 2TX IN THE U-NII 5 BAND

2TX CHAIN 0 + CHAIN 1 OFDMA MODE: 996T

Test Engineer:	85502
Test Date:	2024/02/22

Bandwidth, Antenna Gain and Limits

Channel	Frequency (MHz)	Directional Gain for Power (dBi)	Directional Gain for PSD (dBi)	e.i.r.p. Power Limit (dBm)	PSD Limit (dBm)
Low	5985	4.50	7.30	24.00	-1.00
Mid	6145	4.50	7.30	24.00	-1.00
High	6385	4.50	7.30	24.00	-1.00

Duty Cycle CF (dB)	4.52	Included in Calculations of Corr'dPSD
--------------------	------	---------------------------------------

Output Power Results

Channel	Frequency (MHz)	Chain 0 Meas Power (dBm)	Chain 1 Meas Power (dBm)	Total Corr'd EIRP (dBm)	Power Limit EIRP (dBm)	Power Margin (dB)
Low	5985	4.07	4.60	11.85	24.00	-12.15
Mid	6145	3.67	4.10	11.40	24.00	-12.60
High	6385	3.19	3.24	10.73	24.00	-13.27

PSD Results

Channel	Frequency (MHz)	Chain 0 Meas PSD (dBm)	Chain 1 Meas PSD (dBm)	Total Corr'd PSD (dBm)	PSD EIRP Limit (dBm)	PSD EIRP Margin (dB)
Low	5985	-16.32	-16.66	-1.66	-1.00	-0.66
Mid	6145	-17.17	-16.19	-1.82	-1.00	-0.82
High	6385	-17.98	-15.65	-1.83	-1.00	-0.83

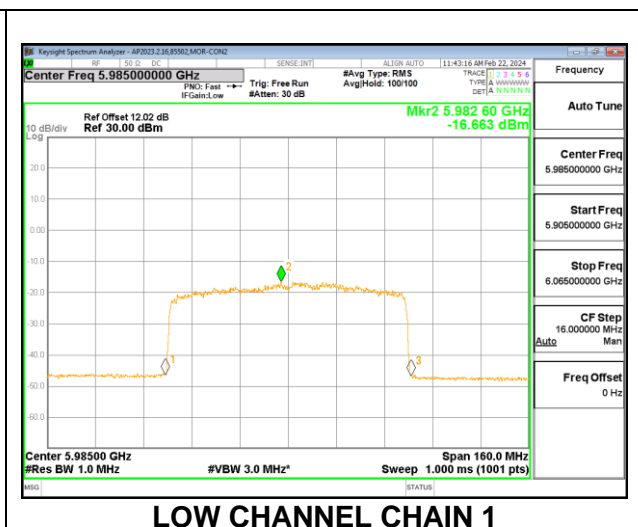
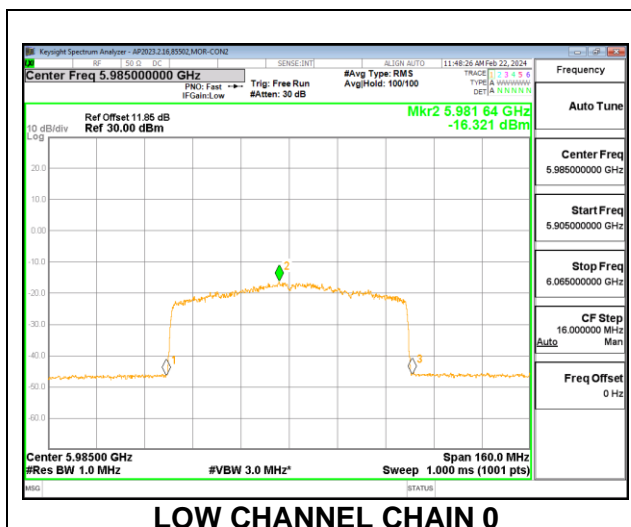

2TX CHAIN 0 + CHAIN 1 OFDMA MODE: SU

Test Engineer:	85502
Test Date:	2024/02/22

Bandwidth, Antenna Gain and Limits

Channel	Frequency (MHz)	Directional Gain for Power (dBi)	Directional Gain for PSD (dBi)	e.i.r.p. Power Limit (dBm)	PSD Limit (dBm)
Low	5985	4.50	7.30	24.00	-1.00
Mid	6145	4.50	7.30	24.00	-1.00
High	6385	4.50	7.30	24.00	-1.00

Duty Cycle CF (dB)	2.37	Included in Calculations of Corr'dPSD
---------------------------	------	--

Output Power Results

Channel	Frequency (MHz)	Chain 0 Meas Power (dBm)	Chain 1 Meas Power (dBm)	Total Corr'd EIRP (dBm)	Power Limit EIRP (dBm)	Power Margin (dB)
Low	5985	4.10	4.59	11.86	24.00	-12.14
Mid	6145	4.76	5.00	12.39	24.00	-11.61
High	6385	3.87	3.86	11.38	24.00	-12.62

PSD Results

Channel	Frequency (MHz)	Chain 0 Meas PSD (dBm)	Chain 1 Meas PSD (dBm)	Total Corr'd PSD (dBm)	PSD EIRP Limit (dBm)	PSD EIRP Margin (dB)
Low	5985	-15.50	-13.93	-1.96	-1.00	-0.96
Mid	6145	-15.01	-13.57	-1.55	-1.00	-0.55
High	6385	-15.97	-13.62	-1.96	-1.00	-0.96

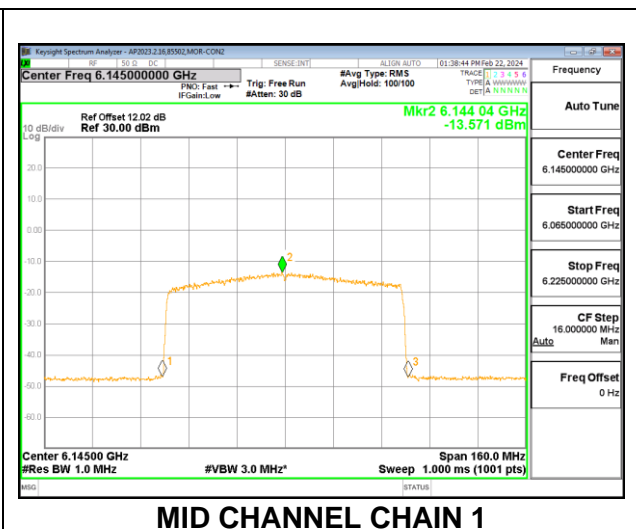
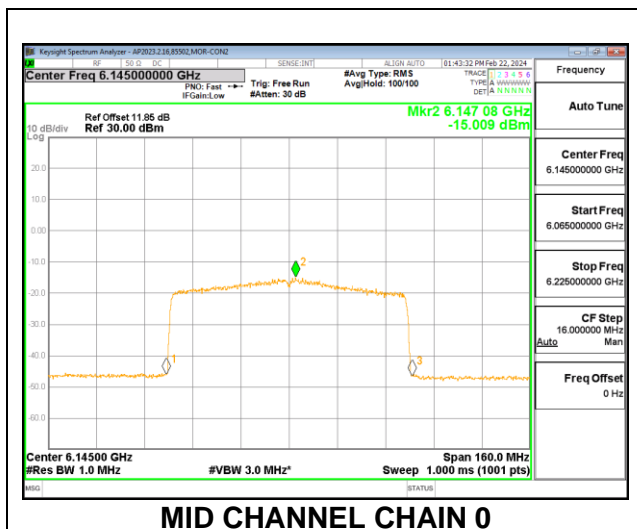

9.2.5. 802.11a MODE 2TX IN THE U-NII 6 BAND

2TX CHAIN 0 + CHAIN 1

Test Engineer:	85502
Test Date:	2024/03/28

Bandwidth, Antenna Gain and Limits

Channel	Frequency (MHz)	Directional Gain for Power (dBi)	Directional Gain for PSD (dBi)	e.i.r.p. Power Limit (dBm)	PSD Limit (dBm)
Low	6435	4.40	7.20	24.00	-1.00
Mid	6475	4.40	7.20	24.00	-1.00
High	6515	4.40	7.20	24.00	-1.00

Duty Cycle CF (dB)	0.94	Included in Calculations of Corr'd PSD
---------------------------	------	---

Output Power Results

Channel	Frequency (MHz)	Chain 0 Meas Power (dBm)	Chain 1 Meas Power (dBm)	Total Corr'd EIRP (dBm)	Power Limit EIRP (dBm)	Power Margin (dB)
Low	6435	-0.41	-0.20	7.11	24.00	-16.89
Mid	6475	-0.42	-0.40	7.00	24.00	-17.00
High	6515	-0.53	-0.82	6.74	24.00	-17.26

PSD Results

Channel	Frequency (MHz)	Chain 0 Meas PSD (dBm)	Chain 1 Meas PSD (dBm)	Total Corr'd PSD (dBm)	PSD EIRP Limit (dBm)	PSD EIRP Margin (dB)
Low	6435	-13.03	-12.97	-1.85	-1.00	-0.85
Mid	6475	-13.12	-13.09	-1.95	-1.00	-0.95
High	6515	-13.03	-12.96	-1.84	-1.00	-0.84

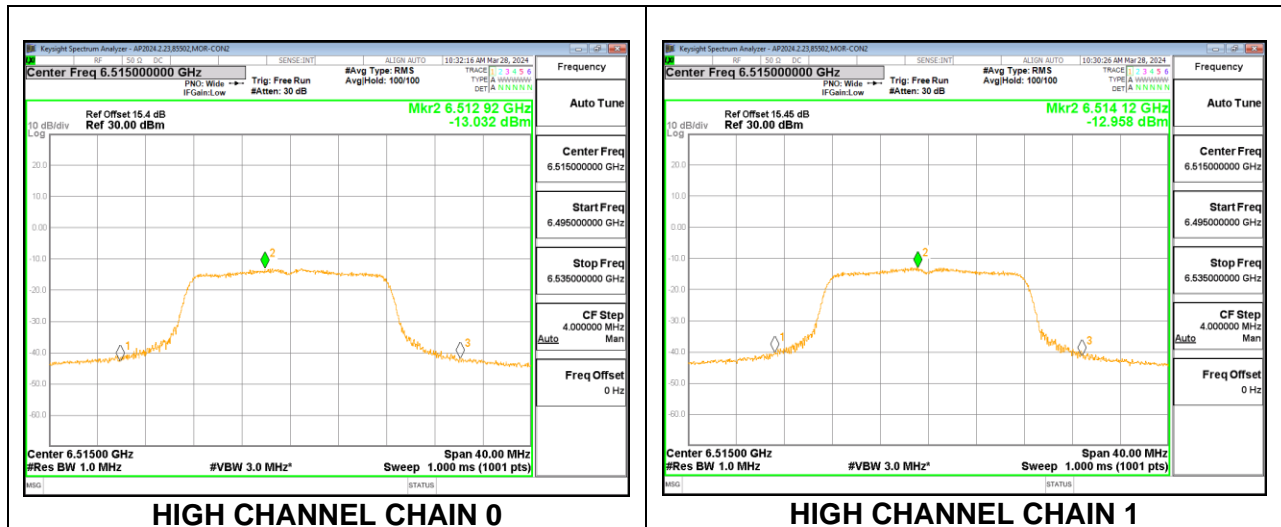

9.2.6. 802.11ax HE20 MODE 2TX IN THE U-NII 6 BAND

2TX CHAIN 0 + CHAIN 1 OFDMA MODE: 26T

Test Engineer:	85502
Test Date:	2024/03/28

Bandwidth, Antenna Gain and Limits

Channel	Frequency (MHz)	Directional Gain for Power (dBi)	Directional Gain for PSD (dBi)	e.i.r.p. Power Limit (dBm)	PSD Limit (dBm)
Low	6435	4.40	7.20	24.00	-1.00
Mid	6475	4.40	7.20	24.00	-1.00
High	6515	4.40	7.20	24.00	-1.00

Duty Cycle CF (dB)	3.11	Included in Calculations of Corr'd PSD
--------------------	------	--

Output Power Results

Channel	Frequency (MHz)	Chain 0 Meas Power (dBm)	Chain 1 Meas Power (dBm)	Total Corr'd EIRP (dBm)	Power Limit EIRP (dBm)	Power Margin (dB)
Low	6435	-7.87	-7.59	-0.32	24.00	-24.32
Mid	6475	-7.73	-7.36	-0.13	24.00	-24.13
High	6515	-8.09	-8.21	-0.74	24.00	-24.74

PSD Results

Channel	Frequency (MHz)	Chain 0 Meas PSD (dBm)	Chain 1 Meas PSD (dBm)	Total Corr'd PSD (dBm)	PSD EIRP Limit (dBm)	PSD EIRP Margin (dB)
Low	6435	-14.97	-14.77	-1.55	-1.00	-0.55
Mid	6475	-15.30	-14.86	-1.75	-1.00	-0.75
High	6515	-14.54	-15.36	-1.61	-1.00	-0.61

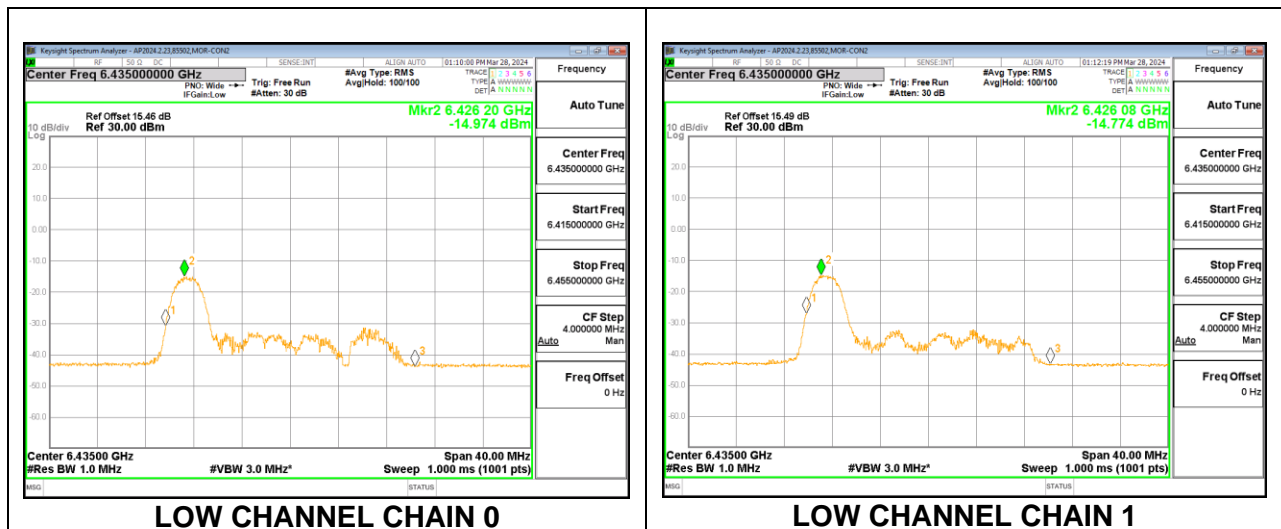

2TX CHAIN 0 + CHAIN 1 OFDMA MODE: 52T

Test Engineer:	85502
Test Date:	2024/03/28

Bandwidth, Antenna Gain and Limits

Channel	Frequency (MHz)	Directional Gain for Power (dBi)	Directional Gain for PSD (dBi)	e.i.r.p. Power Limit (dBm)	PSD Limit (dBm)
Low	6435	4.40	7.20	24.00	-1.00
Mid	6475	4.40	7.20	24.00	-1.00
High	6515	4.40	7.20	24.00	-1.00

Duty Cycle CF (dB)	3.46	Included in Calculations of Corr'd PSD
---------------------------	------	---

Output Power Results

Channel	Frequency (MHz)	Chain 0 Meas Power (dBm)	Chain 1 Meas Power (dBm)	Total Corr'd EIRP (dBm)	Power Limit EIRP (dBm)	Power Margin (dB)
Low	6435	-6.88	-6.93	0.51	24.00	-23.49
Mid	6475	-6.65	-6.61	0.78	24.00	-23.22
High	6515	-7.00	-7.07	0.38	24.00	-23.62

PSD Results

Channel	Frequency (MHz)	Chain 0 Meas PSD (dBm)	Chain 1 Meas PSD (dBm)	Total Corr'd PSD (dBm)	PSD EIRP Limit (dBm)	PSD EIRP Margin (dB)
Low	6435	-15.67	-14.74	-1.51	-1.00	-0.51
Mid	6475	-15.27	-15.66	-1.79	-1.00	-0.79
High	6515	-15.65	-14.89	-1.58	-1.00	-0.58

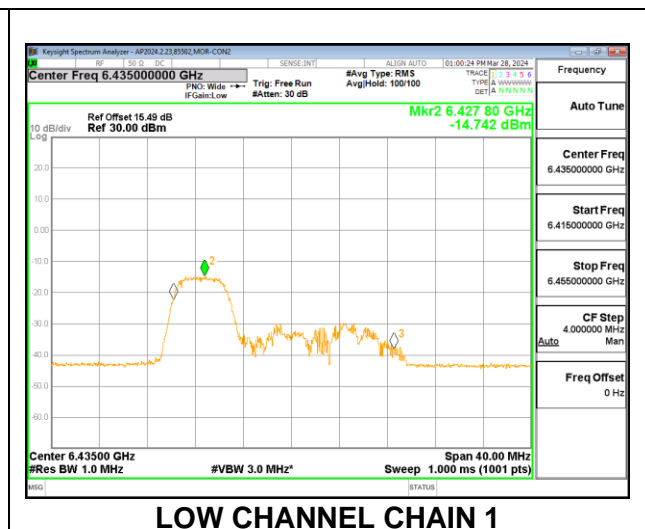
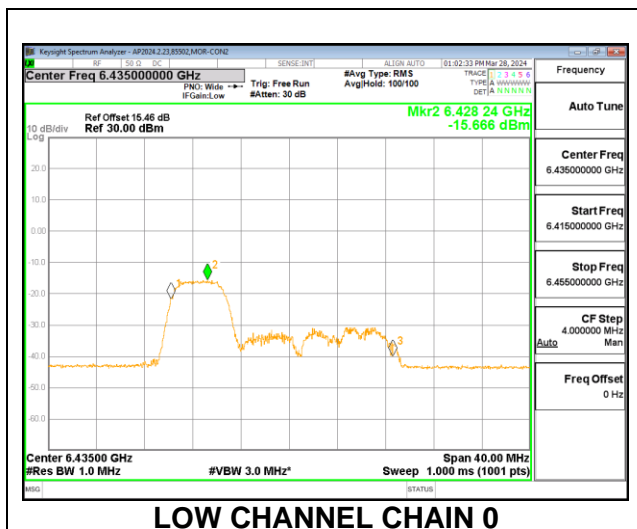

2TX CHAIN 0 + CHAIN 1 OFDMA MODE: 106T

Test Engineer:	84740
Test Date:	2024/03/28

Bandwidth, Antenna Gain and Limits

Channel	Frequency (MHz)	Directional Gain for Power (dBi)	Directional Gain for PSD (dBi)	e.i.r.p. Power Limit (dBm)	PSD Limit (dBm)
Low	6435	4.40	7.20	24.00	-1.00
Mid	6475	4.40	7.20	24.00	-1.00
High	6515	4.40	7.20	24.00	-1.00

Duty Cycle CF (dB)	3.77	Included in Calculations of Corr'd PSD
---------------------------	------	---

Output Power Results

Channel	Frequency (MHz)	Chain 0 Meas Power (dBm)	Chain 1 Meas Power (dBm)	Total Corr'd EIRP (dBm)	Power Limit EIRP (dBm)	Power Margin (dB)
Low	6435	-3.03	-3.37	4.21	24.00	-19.79
Mid	6475	-3.27	-3.31	4.12	24.00	-19.88
High	6515	-3.72	-3.52	3.79	24.00	-20.21

PSD Results

Channel	Frequency (MHz)	Chain 0 Meas PSD (dBm)	Chain 1 Meas PSD (dBm)	Total Corr'd PSD (dBm)	PSD EIRP Limit (dBm)	PSD EIRP Margin (dB)
Low	6435	-15.92	-15.68	-1.82	-1.00	-0.82
Mid	6475	-15.25	-15.86	-1.57	-1.00	-0.57
High	6515	-15.82	-15.54	-1.69	-1.00	-0.69

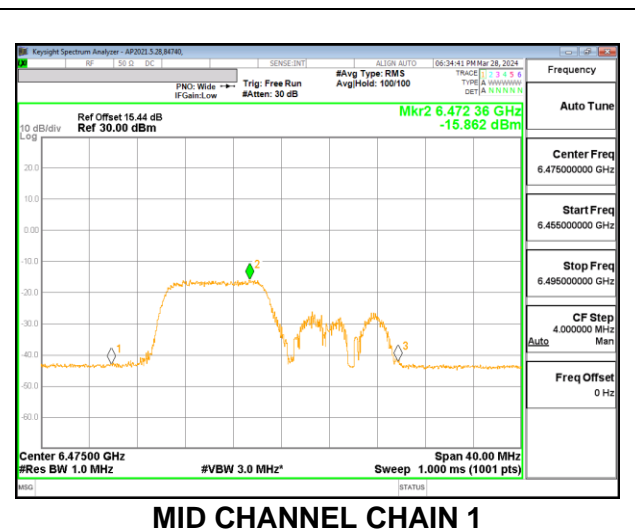
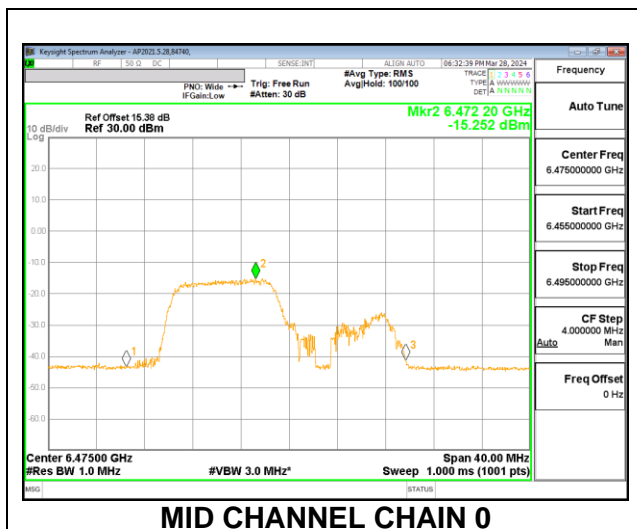

2TX CHAIN 0 + CHAIN 1 OFDMA MODE: 242T

Test Engineer:	84740
Test Date:	2024/03/28

Bandwidth, Antenna Gain and Limits

Channel	Frequency (MHz)	Directional Gain for Power (dBi)	Directional Gain for PSD (dBi)	e.i.r.p. Power Limit (dBm)	PSD Limit (dBm)
Low	6435	4.40	7.20	24.00	-1.00
Mid	6475	4.40	7.20	24.00	-1.00
High	6515	4.40	7.20	24.00	-1.00

Duty Cycle CF (dB)	4.15	Included in Calculations of Corr'd PSD
---------------------------	------	---

Output Power Results

Channel	Frequency (MHz)	Chain 0 Meas Power (dBm)	Chain 1 Meas Power (dBm)	Total Corr'd EIRP (dBm)	Power Limit EIRP (dBm)	Power Margin (dB)
Low	6435	-0.30	-0.31	7.11	24.00	-16.89
Mid	6475	-0.55	-0.66	6.81	24.00	-17.19
High	6515	-0.44	-0.53	6.93	24.00	-17.07

PSD Results

Channel	Frequency (MHz)	Chain 0 Meas PSD (dBm)	Chain 1 Meas PSD (dBm)	Total Corr'd PSD (dBm)	PSD EIRP Limit (dBm)	PSD EIRP Margin (dB)
Low	6435	-15.31	-16.90	-1.67	-1.00	-0.67
Mid	6475	-15.71	-16.18	-1.58	-1.00	-0.58
High	6515	-16.02	-16.46	-1.87	-1.00	-0.87

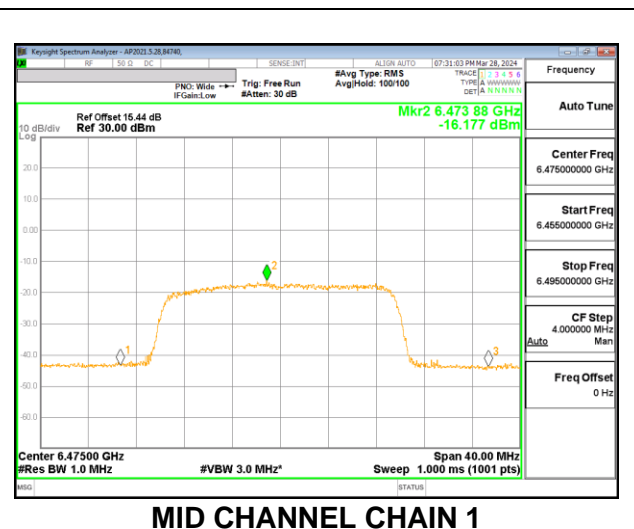
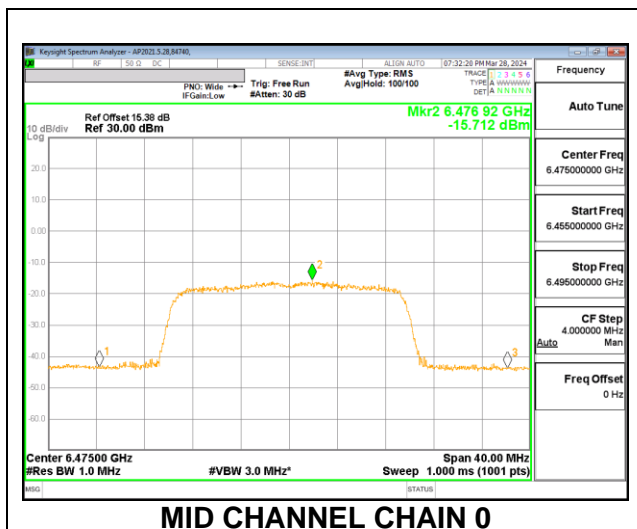

2TX CHAIN 0 + CHAIN 1 OFDMA MODE: SU

Test Engineer:	84740
Test Date:	2024/03/28

Bandwidth, Antenna Gain and Limits

Channel	Frequency (MHz)	Directional Gain for Power (dBi)	Directional Gain for PSD (dBi)	e.i.r.p. Power Limit (dBm)	PSD Limit (dBm)
Low	6435	4.40	7.20	24.00	-1.00
Mid	6475	4.40	7.20	24.00	-1.00
High	6515	4.40	7.20	24.00	-1.00

Duty Cycle CF (dB)	0.74	Included in Calculations of Corr'd PSD
---------------------------	------	---

Output Power Results

Channel	Frequency (MHz)	Chain 0 Meas Power (dBm)	Chain 1 Meas Power (dBm)	Total Corr'd EIRP (dBm)	Power Limit EIRP (dBm)	Power Margin (dB)
Low	6435	-0.07	-0.10	7.33	24.00	-16.67
Mid	6475	0.18	-0.01	7.50	24.00	-16.50
High	6515	-0.32	-0.51	7.00	24.00	-17.00

PSD Results

Channel	Frequency (MHz)	Chain 0 Meas PSD (dBm)	Chain 1 Meas PSD (dBm)	Total Corr'd PSD (dBm)	PSD EIRP Limit (dBm)	PSD EIRP Margin (dB)
Low	6435	-12.62	-13.31	-2.00	-1.00	-1.00
Mid	6475	-12.17	-13.04	-1.63	-1.00	-0.63
High	6515	-12.79	-12.66	-1.78	-1.00	-0.78

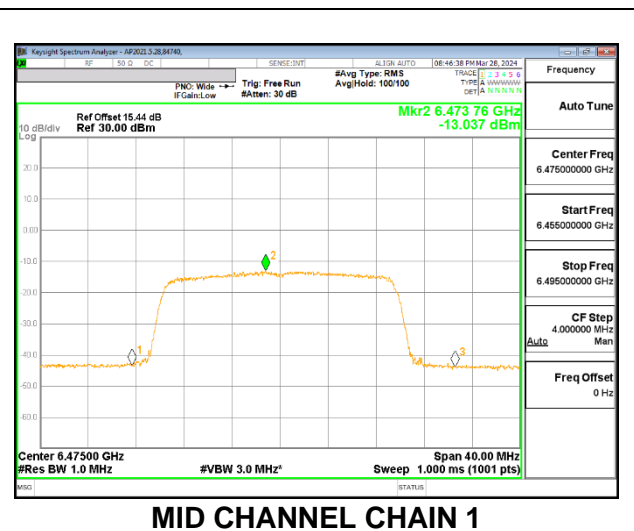
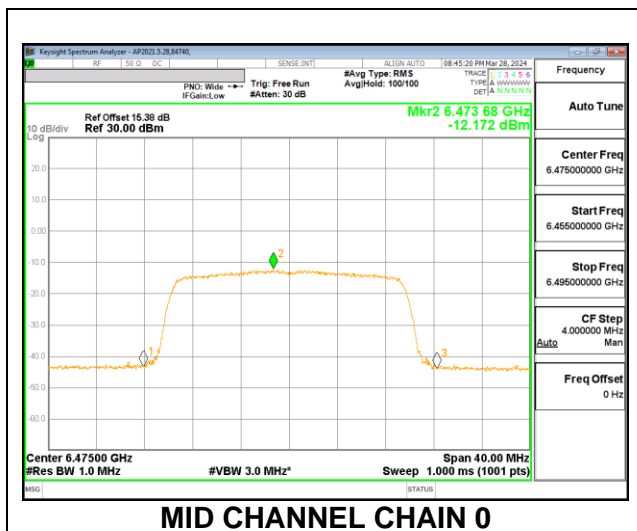

9.2.7. 802.11ax HE40 MODE 2TX IN THE U-NII 6 BAND

2TX CHAIN 0 + CHAIN 1 OFDMA MODE: 484T

Test Engineer:	84740
Test Date:	2024/03/28

Bandwidth, Antenna Gain and Limits

Channel	Frequency (MHz)	Directional Gain for Power (dBi)	Directional Gain for PSD (dBi)	e.i.r.p. Power Limit (dBm)	PSD Limit (dBm)
Low	6445	4.40	7.20	24.00	-1.00
Mid	6485	4.40	7.20	24.00	-1.00
High	6525	4.40	7.20	24.00	-1.00

Duty Cycle CF (dB)	4.25	Included in Calculations of Corr'd PSD
--------------------	------	--

Output Power Results

Channel	Frequency (MHz)	Chain 0 Meas Power (dBm)	Chain 1 Meas Power (dBm)	Total Corr'd EIRP (dBm)	Power Limit EIRP (dBm)	Power Margin (dB)
Low	6445	1.83	2.24	9.45	24.00	-14.55
Mid	6485	1.25	1.90	9.00	24.00	-15.00
High	6525	1.82	2.34	9.50	24.00	-14.50

PSD Results

Channel	Frequency (MHz)	Chain 0 Meas PSD (dBm)	Chain 1 Meas PSD (dBm)	Total Corr'd PSD (dBm)	PSD EIRP Limit (dBm)	PSD EIRP Margin (dB)
Low	6445	-16.18	-16.27	-1.76	-1.00	-0.76
Mid	6485	-16.63	-16.02	-1.86	-1.00	-0.86
High	6525	-16.63	-15.57	-1.61	-1.00	-0.61

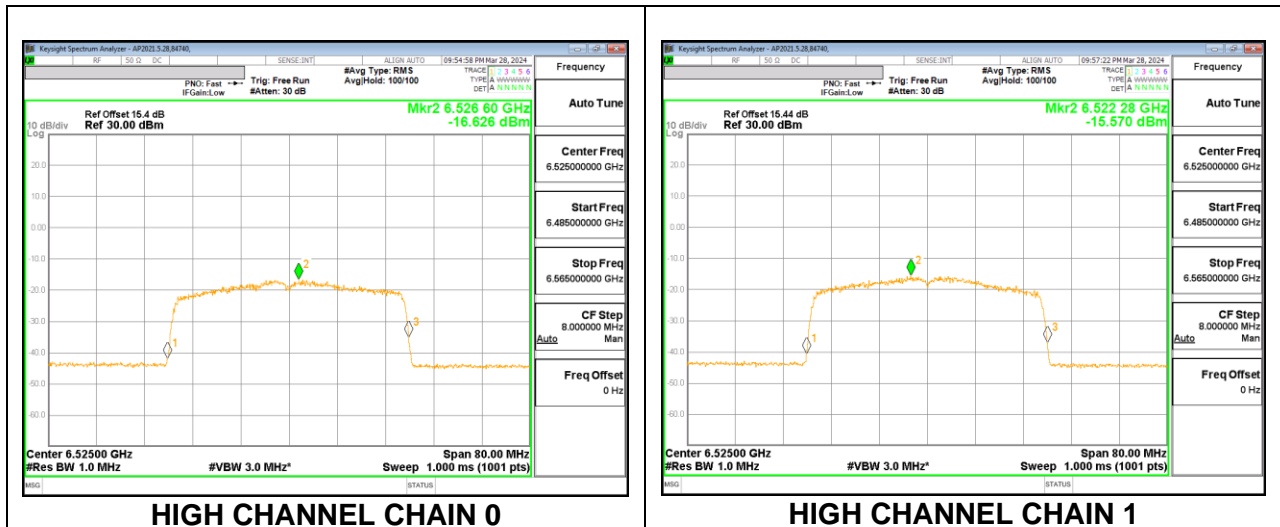

2TX CHAIN 0 + CHAIN 1 OFDMA MODE: SU

Test Engineer:	84740
Test Date:	2024/03/28

Bandwidth, Antenna Gain and Limits

Channel	Frequency (MHz)	Directional Gain for Power (dBi)	Directional Gain for PSD (dBi)	e.i.r.p. Power Limit (dBm)	PSD Limit (dBm)
Low	6445	4.40	7.20	24.00	-1.00
Middle	6485	4.40	7.20	24.00	-1.00
High	6525	4.40	7.20	24.00	-1.00

Duty Cycle CF (dB)	1.32	Included in Calculations of Corr'd PSD
---------------------------	------	---

Output Power Results

Channel	Frequency (MHz)	Chain 0 Meas Power (dBm)	Chain 1 Meas Power (dBm)	Total Corr'd EIRP (dBm)	Power Limit EIRP (dBm)	Power Margin (dB)
Low	6445	3.02	2.81	10.33	24.00	-13.67
Middle	6485	2.16	2.17	9.58	24.00	-14.42
High	6525	2.34	2.56	9.86	24.00	-14.14

PSD Results

Channel	Frequency (MHz)	Chain 0 Meas PSD (dBm)	Chain 1 Meas PSD (dBm)	Total Corr'd PSD (dBm)	PSD EIRP Limit (dBm)	PSD EIRP Margin (dB)
Low	6445	-13.68	-13.11	-1.85	-1.00	-0.85
Middle	6485	-13.78	-13.09	-1.89	-1.00	-0.89
High	6525	-13.59	-13.17	-1.85	-1.00	-0.85

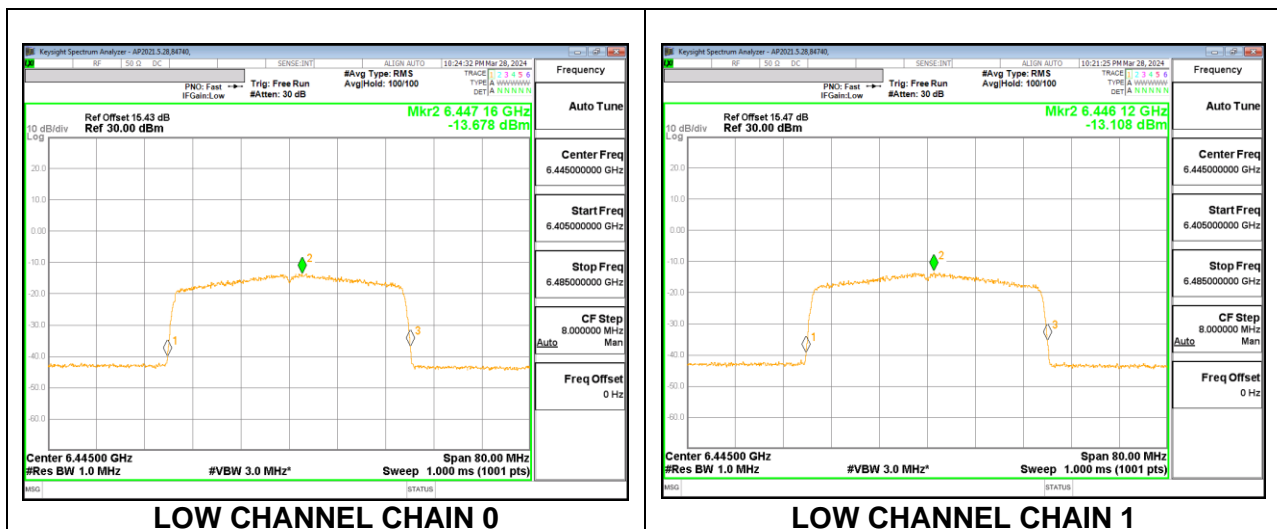

9.2.8. 802.11ax HE80 MODE 2TX IN THE U-NII 6 BAND

2TX CHAIN 0 + CHAIN 1 OFDMA MODE: 996T

Test Engineer:	84740
Test Date:	2024/03/28

Bandwidth, Antenna Gain and Limits

Channel	Frequency (MHz)	Directional Gain for Power (dBi)	Directional Gain for PSD (dBi)	e.i.r.p. Power Limit (dBm)	PSD Limit (dBm)
Low	6465	4.40	7.20	24.00	-1.00
High	6545	4.40	7.20	24.00	-1.00

Duty Cycle CF (dB)	4.52	Included in Calculations of Corr'd PSD
--------------------	------	--

Output Power Results

Channel	Frequency (MHz)	Chain 0 Meas Power (dBm)	Chain 1 Meas Power (dBm)	Total Corr'd EIRP (dBm)	Power Limit EIRP (dBm)	Power Margin (dB)
Low	6465	4.57	4.66	12.03	24.00	-11.97
High	6545	4.80	4.51	12.07	24.00	-11.93

PSD Results

Channel	Frequency (MHz)	Chain 0 Meas PSD (dBm)	Chain 1 Meas PSD (dBm)	Total Corr'd PSD (dBm)	PSD EIRP Limit (dBm)	PSD EIRP Margin (dB)
Low	6465	-16.53	-16.51	-1.79	-1.00	-0.79
High	6545	-17.09	-16.29	-1.94	-1.00	-0.94

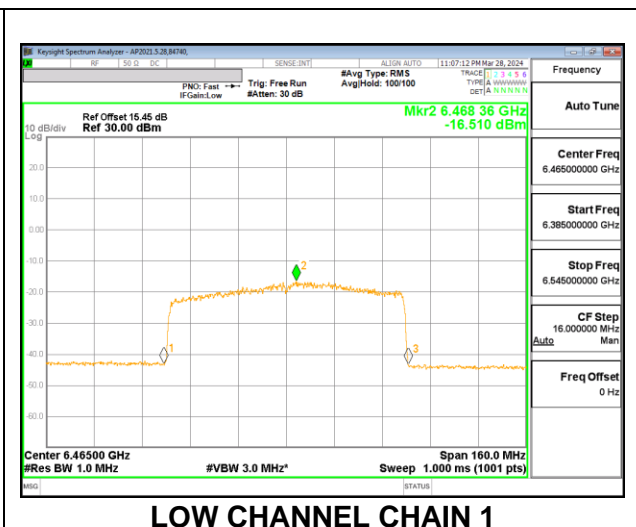
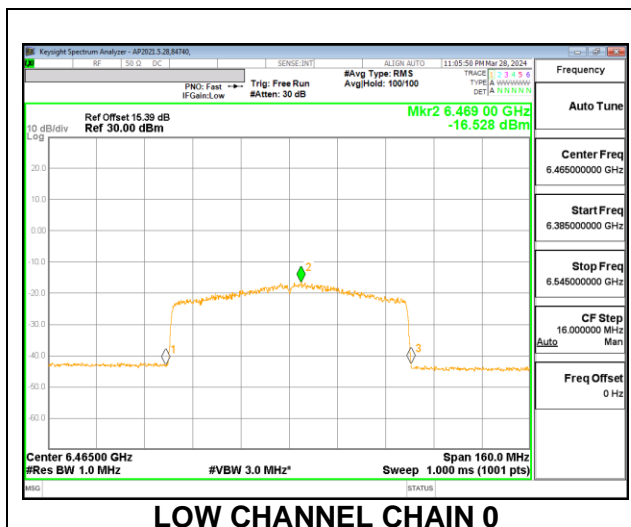

2TX CHAIN 0 + CHAIN 1 OFDMA MODE: SU

Test Engineer:	84740
Test Date:	2024/03/28

Bandwidth, Antenna Gain and Limits

Channel	Frequency (MHz)	Directional Gain for Power (dBi)	Directional Gain for PSD (dBi)	e.i.r.p. Power Limit (dBm)	PSD Limit (dBm)
Low	6465	4.40	7.20	24.00	-1.00
High	6545	4.40	7.20	24.00	-1.00

Duty Cycle CF (dB)	2.37	Included in Calculations of Corr'd PSD
---------------------------	------	---

Output Power Results

Channel	Frequency (MHz)	Chain 0 Meas Power (dBm)	Chain 1 Meas Power (dBm)	Total Corr'd EIRP (dBm)	Power Limit EIRP (dBm)	Power Margin (dB)
Low	6465	5.05	5.02	12.45	24.00	-11.55
High	6545	5.90	5.57	13.15	24.00	-10.85

PSD Results

Channel	Frequency (MHz)	Chain 0 Meas PSD (dBm)	Chain 1 Meas PSD (dBm)	Total Corr'd PSD (dBm)	PSD EIRP Limit (dBm)	PSD EIRP Margin (dB)
Low	6465	-14.34	-14.71	-1.94	-1.00	-0.94
High	6545	-13.66	-14.60	-1.52	-1.00	-0.52

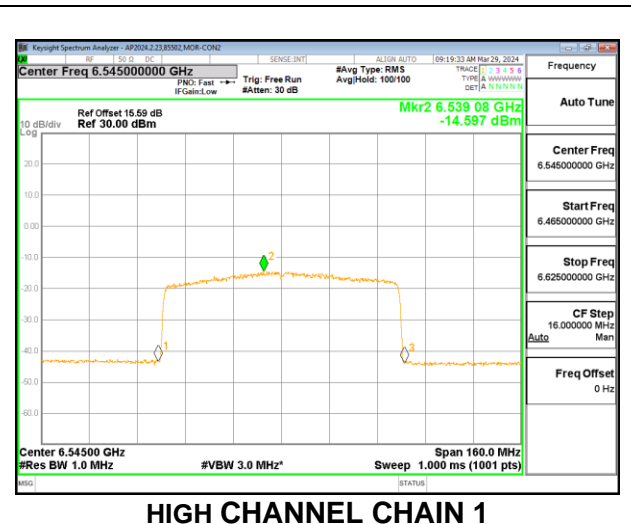
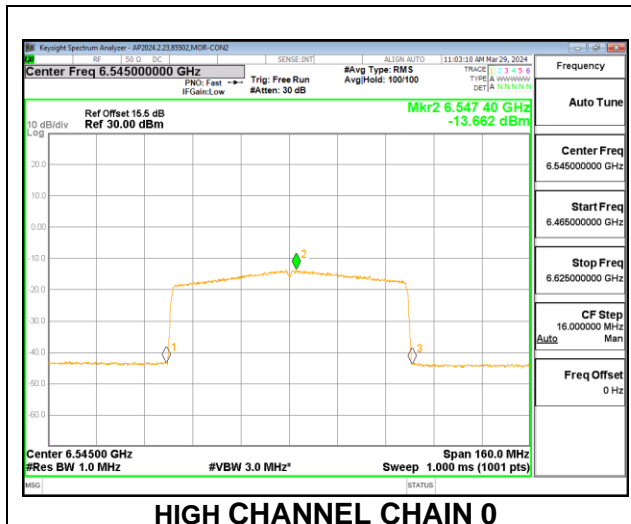

9.2.9. 802.11a MODE 2TX IN THE U-NII 7 BAND

2TX CHAIN 0 + CHAIN 1 MODE

Test Engineer:	85502
Test Date:	2024/04/01

Bandwidth, Antenna Gain and Limits

Channel	Frequency (MHz)	Directional Gain for Power (dBi)	Directional Gain for PSD (dBi)	e.i.r.p. Power Limit (dBm)	PSD Limit (dBm)
Low	6535	4.50	7.20	24.00	-1.00
Mid	6715	4.50	7.20	24.00	-1.00
High	6855	4.50	7.20	24.00	-1.00

Duty Cycle CF (dB)	0.94	Included in Calculations of Corr'd PSD
--------------------	------	--

Output Power Results

Channel	Frequency (MHz)	Chain 0 Meas Power (dBm)	Chain 1 Meas Power (dBm)	Total Corr'd EIRP (dBm)	Power Limit EIRP (dBm)	Power Margin (dB)
Low	6535	-0.23	-0.72	7.04	24.00	-16.96
Mid	6715	-0.87	-0.28	6.95	24.00	-17.05
High	6855	-1.78	-0.67	6.32	24.00	-17.68

PSD Results

Channel	Frequency (MHz)	Chain 0 Meas PSD (dBm)	Chain 1 Meas PSD (dBm)	Total Corr'd PSD (dBm)	PSD EIRP Limit (dBm)	PSD EIRP Margin (dB)
Low	6535	-12.46	-12.91	-1.52	-1.00	-0.52
Mid	6715	-13.70	-12.63	-1.98	-1.00	-0.98
High	6855	-13.57	-12.73	-1.98	-1.00	-0.98

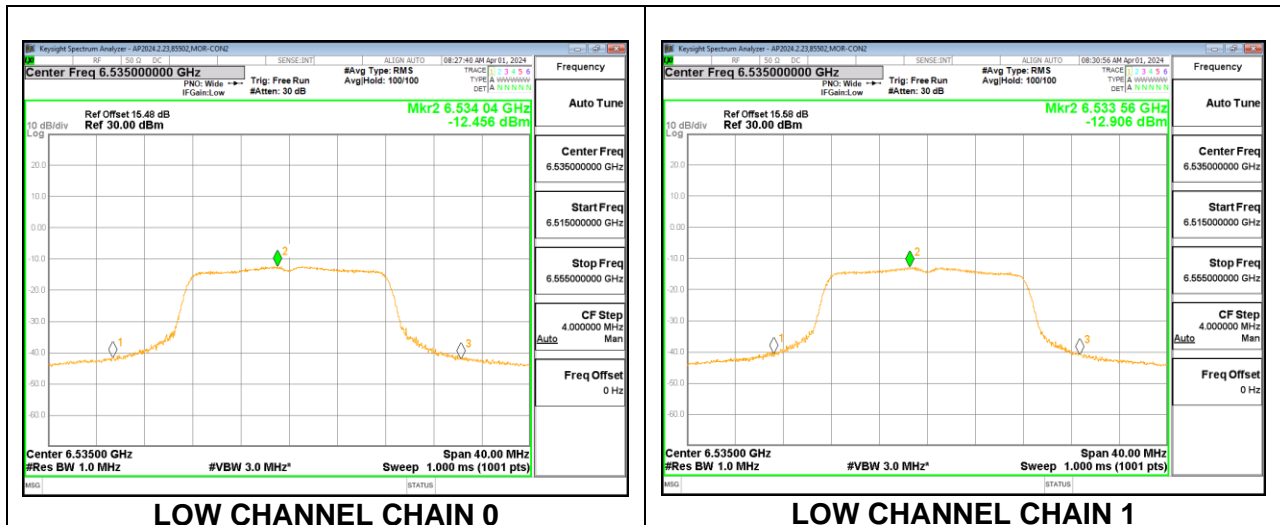

9.2.10. 802.11ax HE20 MODE 2TX IN THE U-NII 7 BAND

2TX CHAIN 0 + CHAIN 1 OFDMA MODE: 26T

Test Engineer:	85502
Test Date:	2024/04/01

Bandwidth, Antenna Gain and Limits

Channel	Frequency (MHz)	Directional Gain for Power (dBi)	Directional Gain for PSD (dBi)	e.i.r.p. Power Limit (dBm)	PSD Limit (dBm)
Low	6535	4.50	7.20	24.00	-1.00
Mid	6715	4.50	7.20	24.00	-1.00
High	6855	4.50	7.20	24.00	-1.00

Duty Cycle CF (dB)	3.11	Included in Calculations of Corr'd PSD
---------------------------	------	---

Output Power Results

Channel	Frequency (MHz)	Chain 0 Meas Power (dBm)	Chain 1 Meas Power (dBm)	Total Corr'd EIRP (dBm)	Power Limit EIRP (dBm)	Power Margin (dB)
Low	6535	-8.61	-8.64	-1.11	24.00	-25.11
Mid	6715	-8.15	-7.06	-0.06	24.00	-24.06
High	6855	-8.69	-7.67	-0.64	24.00	-24.64

PSD Results

Channel	Frequency (MHz)	Chain 0 Meas PSD (dBm)	Chain 1 Meas PSD (dBm)	Total Corr'd PSD (dBm)	PSD EIRP Limit (dBm)	PSD EIRP Margin (dB)
Low	6535	-15.02	-14.68	-1.52	-1.00	-0.52
Mid	6715	-15.66	-14.69	-1.83	-1.00	-0.83
High	6855	-14.86	-14.81	-1.51	-1.00	-0.51

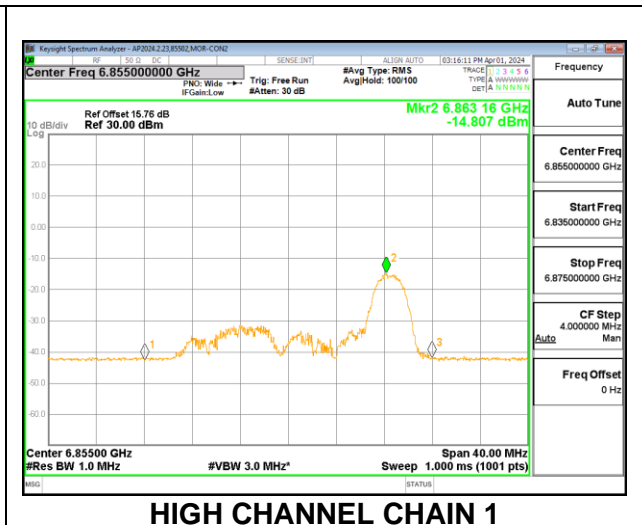
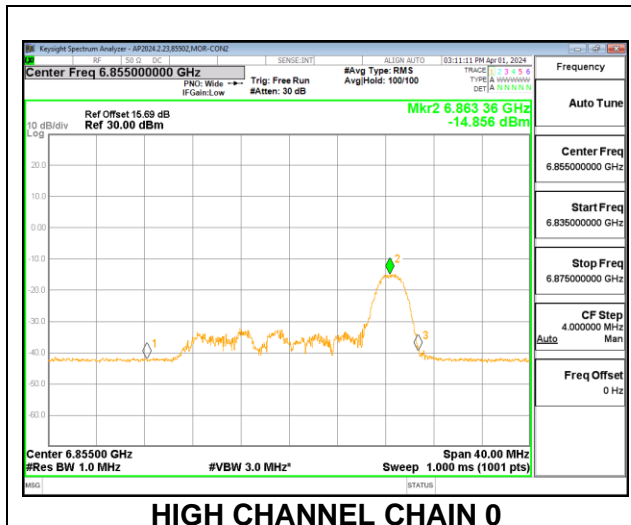

2TX CHAIN 0 + CHAIN 1 OFDMA MODE: 52T

Test Engineer:	85502
Test Date:	2024/04/01

Bandwidth, Antenna Gain and Limits

Channel	Frequency (MHz)	Directional Gain for Power (dBi)	Directional Gain for PSD (dBi)	e.i.r.p. Power Limit (dBm)	PSD Limit (dBm)
Low	6535	4.50	7.20	24.00	-1.00
Mid	6715	4.50	7.20	24.00	-1.00
High	6855	4.50	7.20	24.00	-1.00

Duty Cycle CF (dB)	3.46	Included in Calculations of Corr'd PSD
---------------------------	------	---

Output Power Results

Channel	Frequency (MHz)	Chain 0 Meas Power (dBm)	Chain 1 Meas Power (dBm)	Total Corr'd EIRP (dBm)	Power Limit EIRP (dBm)	Power Margin (dB)
Low	6535	-7.45	-7.92	-0.17	24.00	-24.17
Mid	6715	-7.60	-6.39	0.56	24.00	-23.44
High	6855	-8.05	-7.05	-0.01	24.00	-24.01

PSD Results

Channel	Frequency (MHz)	Chain 0 Meas PSD (dBm)	Chain 1 Meas PSD (dBm)	Total Corr'd PSD (dBm)	PSD EIRP Limit (dBm)	PSD EIRP Margin (dB)
Low	6535	-15.85	-15.44	-1.97	-1.00	-0.97
Mid	6715	-16.26	-15.07	-1.95	-1.00	-0.95
High	6855	-15.80	-15.31	-1.88	-1.00	-0.88

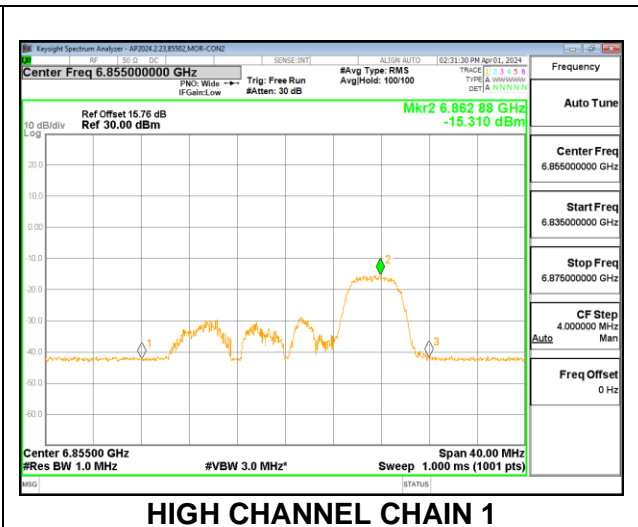
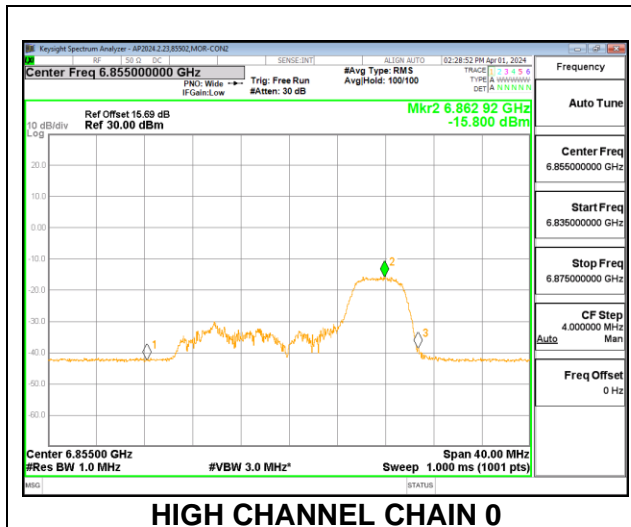

2TX CHAIN 0 + CHAIN 1 OFDMA MODE: 106T

Test Engineer:	85502
Test Date:	2024/04/01

Bandwidth, Antenna Gain and Limits

Channel	Frequency (MHz)	Directional Gain for Power (dBi)	Directional Gain for PSD (dBi)	e.i.r.p. Power Limit (dBm)	PSD Limit (dBm)
Low	6535	4.50	7.20	24.00	-1.00
Mid	6715	4.50	7.20	24.00	-1.00
High	6855	4.50	7.20	24.00	-1.00

Duty Cycle CF (dB)	3.77	Included in Calculations of Corr'd PSD
---------------------------	------	---

Output Power Results

Channel	Frequency (MHz)	Chain 0 Meas Power (dBm)	Chain 1 Meas Power (dBm)	Total Corr'd EIRP (dBm)	Power Limit EIRP (dBm)	Power Margin (dB)
Low	6535	-3.70	-4.12	3.61	24.00	-20.39
Mid	6715	-4.62	-3.32	3.59	24.00	-20.41
High	6855	-4.75	-3.55	3.40	24.00	-20.60

PSD Results

Channel	Frequency (MHz)	Chain 0 Meas PSD (dBm)	Chain 1 Meas PSD (dBm)	Total Corr'd PSD (dBm)	PSD EIRP Limit (dBm)	PSD EIRP Margin (dB)
Low	6535	-15.35	-15.96	-1.66	-1.00	-0.66
Mid	6715	-15.96	-15.57	-1.78	-1.00	-0.78
High	6855	-16.02	-15.77	-1.91	-1.00	-0.91

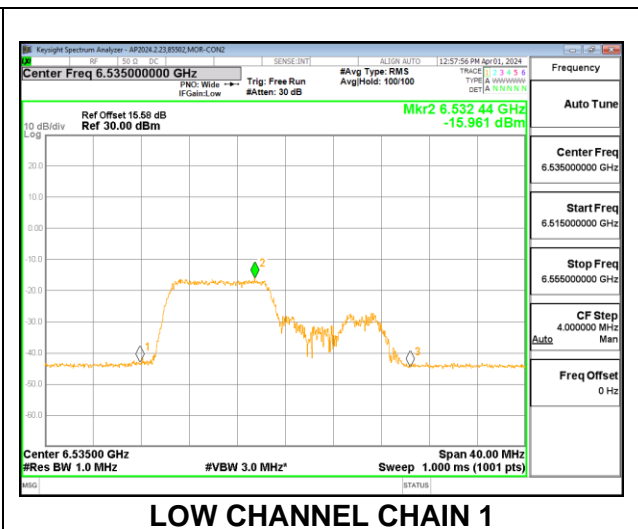
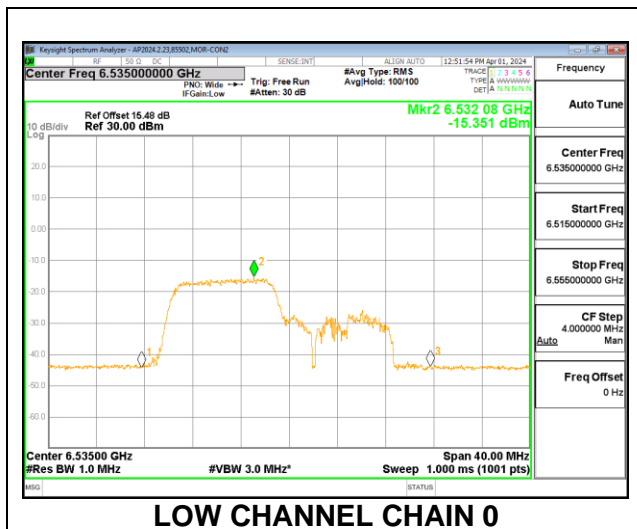

2TX CHAIN 0 + CHAIN 1 OFDMA MODE: 242T

Test Engineer:	85502
Test Date:	2024/04/01

Bandwidth, Antenna Gain and Limits

Channel	Frequency (MHz)	Directional Gain for Power (dBi)	Directional Gain for PSD (dBi)	e.i.r.p. Power Limit (dBm)	PSD Limit (dBm)
Low	6535	4.50	7.20	24.00	-1.00
Mid	6715	4.50	7.20	24.00	-1.00
High	6855	4.50	7.20	24.00	-1.00

Duty Cycle CF (dB)	4.16	Included in Calculations of Corr'd PSD
---------------------------	------	---

Output Power Results

Channel	Frequency (MHz)	Chain 0 Meas Power (dBm)	Chain 1 Meas Power (dBm)	Total Corr'd EIRP (dBm)	Power Limit EIRP (dBm)	Power Margin (dB)
Low	6535	-0.86	1.39	7.92	24.00	-16.08
Mid	6715	-0.93	0.15	7.15	24.00	-16.85
High	6855	-1.12	-0.02	6.98	24.00	-17.02

PSD Results

Channel	Frequency (MHz)	Chain 0 Meas PSD (dBm)	Chain 1 Meas PSD (dBm)	Total Corr'd PSD (dBm)	PSD EIRP Limit (dBm)	PSD EIRP Margin (dB)
Low	6535	-16.23	-15.79	-1.63	-1.00	-0.63
Mid	6715	-17.07	-14.93	-1.50	-1.00	-0.50
High	6855	-16.35	-15.89	-1.74	-1.00	-0.74

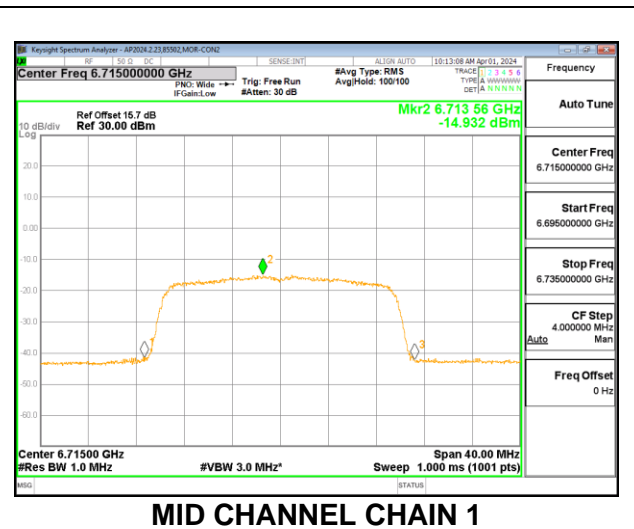
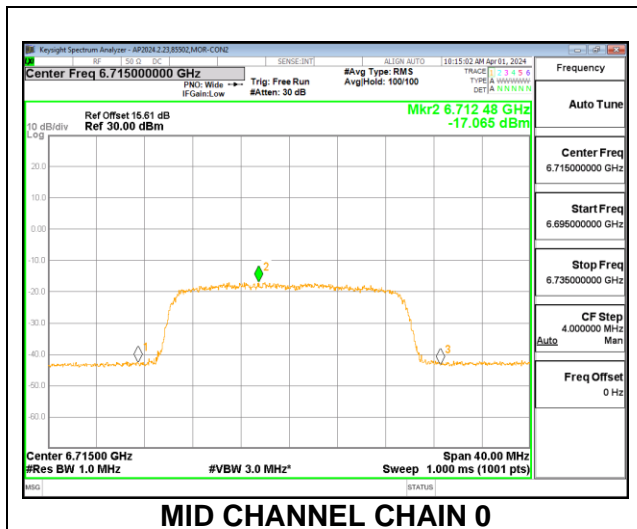

2TX CHAIN 0 + CHAIN 1 OFDMA MODE: SU

Test Engineer:	85502
Test Date:	2024/04/01

Bandwidth, Antenna Gain and Limits

Channel	Frequency (MHz)	Directional Gain for Power (dBi)	Directional Gain for PSD (dBi)	e.i.r.p. Power Limit (dBm)	PSD Limit (dBm)
Low	6535	4.50	7.20	24.00	-1.00
Mid	6715	4.50	7.20	24.00	-1.00
High	6855	4.50	7.20	24.00	-1.00

Duty Cycle CF (dB)	0.74	Included in Calculations of Corr'd PSD
---------------------------	------	---

Output Power Results

Channel	Frequency (MHz)	Chain 0 Meas Power (dBm)	Chain 1 Meas Power (dBm)	Total Corr'd EIRP (dBm)	Power Limit EIRP (dBm)	Power Margin (dB)
Low	6535	-0.16	-0.40	7.23	24.00	-16.77
Mid	6715	-0.31	0.61	7.68	24.00	-16.32
High	6855	-0.66	0.58	7.51	24.00	-16.49

PSD Results

Channel	Frequency (MHz)	Chain 0 Meas PSD (dBm)	Chain 1 Meas PSD (dBm)	Total Corr'd PSD (dBm)	PSD EIRP Limit (dBm)	PSD EIRP Margin (dB)
Low	6535	-12.22	-12.86	-1.57	-1.00	-0.57
Mid	6715	-13.58	-11.92	-1.72	-1.00	-0.72
High	6855	-12.82	-12.85	-1.88	-1.00	-0.88

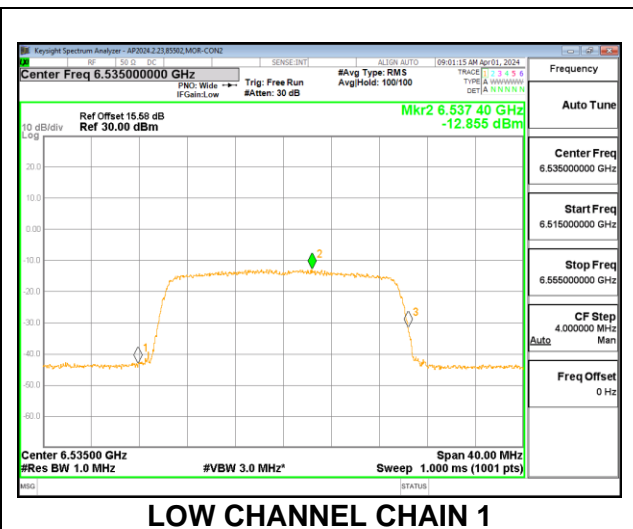
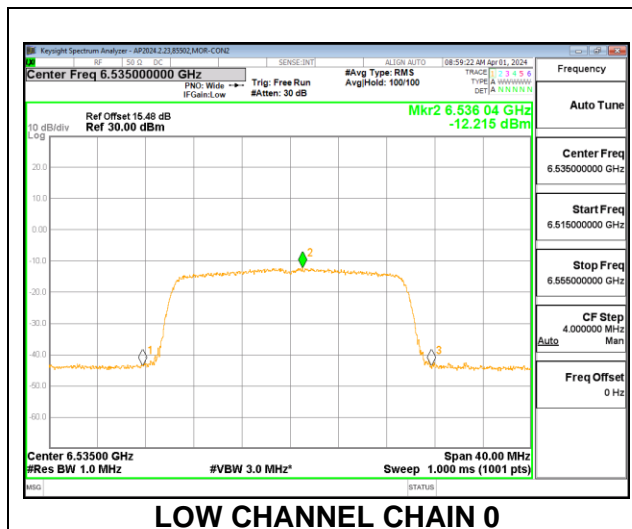

9.2.11. 802.11ax HE40 MODE 2TX IN THE U-NII 7 BAND

2TX CHAIN 0 + CHAIN 1 OFDMA MODE: 484T

Test Engineer:	85502
Test Date:	2024/04/02

Bandwidth, Antenna Gain and Limits

Channel	Frequency (MHz)	Directional Gain for Power (dBi)	Directional Gain for PSD (dBi)	e.i.r.p. Power Limit (dBm)	PSD Limit (dBm)
Low	6565	4.50	7.20	24.00	-1.00
Mid	6685	4.50	7.20	24.00	-1.00
High	6845	4.50	7.20	24.00	-1.00

Duty Cycle CF (dB)	4.25	Included in Calculations of Corr'd PSD
---------------------------	------	---

Output Power Results

Channel	Frequency (MHz)	Chain 0 Meas. Power (dBm)	Chain 1 Meas. Power (dBm)	Total Corr'd EIRP (dBm)	Power Limit EIRP (dBm)	Power Margin (dB)
Low	6565	1.60	0.96	8.80	24.00	-15.20
Mid	6685	2.03	0.70	8.93	24.00	-15.07
High	6845	1.66	0.30	8.54	24.00	-15.46

PSD Results

Channel	Frequency (MHz)	Antenna 1 Meas. PSD (dBm)	Antenna 2 Meas. PSD (dBm)	Total Corr'd PSD (dBm)	PSD EIRP Limit (dBm)	PSD EIRP Margin (dB)
Low	6565	-16.19	-16.70	-1.97	-1.00	-0.97
Mid	6685	-17.14	-15.36	-1.70	-1.00	-0.70
High	6845	-17.48	-15.33	-1.81	-1.00	-0.81

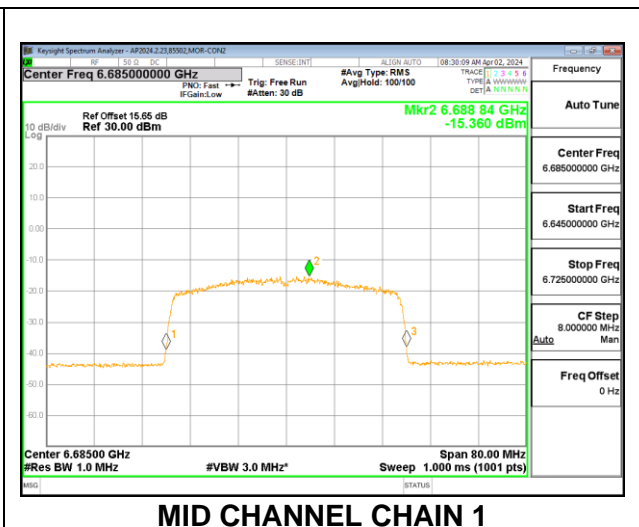
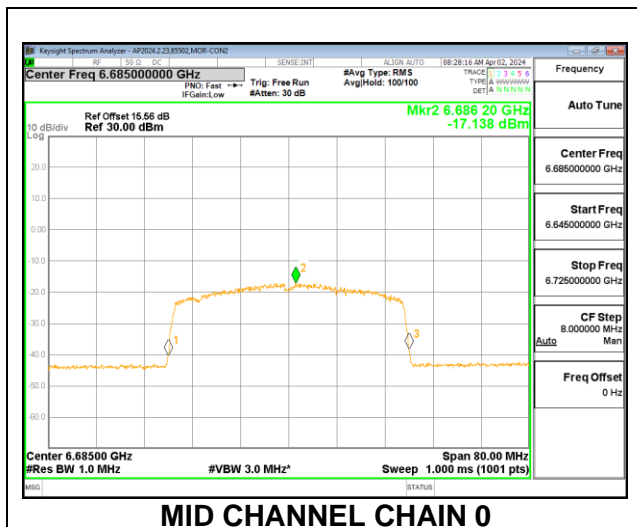

2TX CHAIN 0 + CHAIN 1 OFDMA MODE: SU

Test Engineer:	85502
Test Date:	2024/04/02

Bandwidth, Antenna Gain and Limits

Channel	Frequency (MHz)	Directional Gain for Power (dBi)	Directional Gain for PSD (dBi)	e.i.r.p. Power Limit (dBm)	PSD Limit (dBm)
Low	6565	4.50	7.20	24.00	-1.00
Mid	6685	4.50	7.20	24.00	-1.00
High	6845	4.50	7.20	24.00	-1.00

Duty Cycle CF (dB)	1.32	Included in Calculations of Corr'd PSD
---------------------------	------	---

Output Power Results

Channel	Frequency (MHz)	Chain 0 Meas. Power (dBm)	Chain 1 Meas. Power (dBm)	Total Corr'd EIRP (dBm)	Power Limit EIRP (dBm)	Power Margin (dB)
Low	6565	1.79	1.05	8.95	24.00	-15.05
Mid	6685	2.15	0.97	9.11	24.00	-14.89
High	6845	2.79	1.96	9.91	24.00	-14.09

PSD Results

Channel	Frequency (MHz)	Antenna 1 Meas. PSD (dBm)	Antenna 2 Meas. PSD (dBm)	Total Corr'd PSD (dBm)	PSD EIRP Limit (dBm)	PSD EIRP Margin (dB)
Low	6565	-13.61	-13.00	-1.76	-1.00	-0.76
Mid	6685	-13.49	-12.73	-1.56	-1.00	-0.56
High	6845	-13.86	-12.42	-1.55	-1.00	-0.55

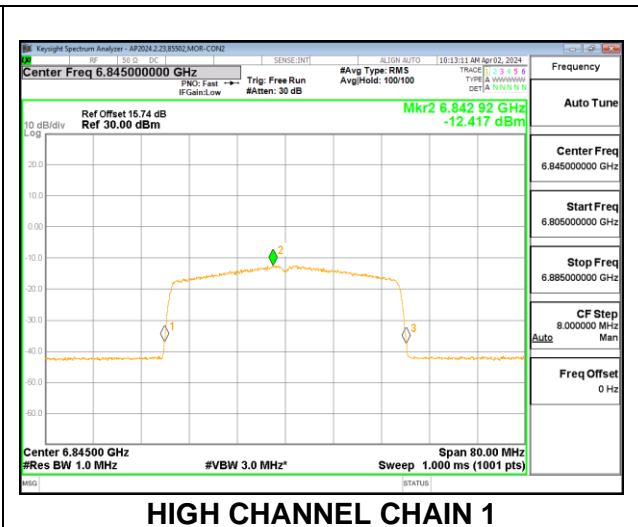
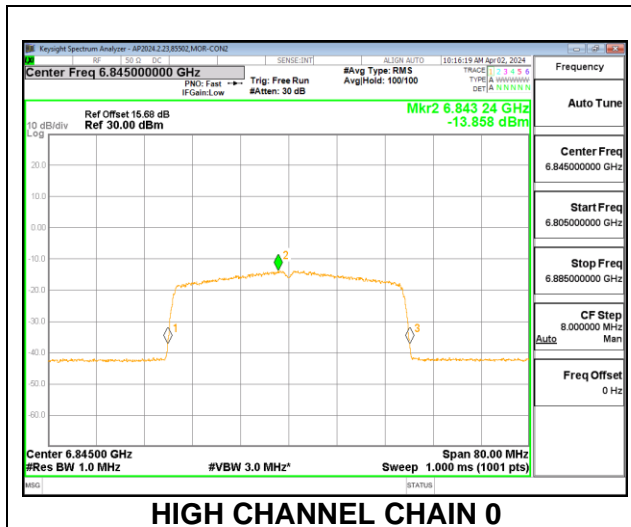

9.2.12. 802.11ax HE80 MODE 2TX IN THE U-NII 7 BAND

2TX CHAIN 0 + CHAIN 1 OFDMA MODE: 996T

Test Engineer:	85502
Test Date:	2024/04/02

Bandwidth, Antenna Gain and Limits

Channel	Frequency (MHz)	Directional Gain for Power (dBi)	Directional Gain for PSD (dBi)	e.i.r.p. Power Limit (dBm)	PSD Limit (dBm)
Low	6625	4.50	7.20	24.00	-1.00
Mid	6705	4.50	7.20	24.00	-1.00
High	6785	4.50	7.20	24.00	-1.00

Duty Cycle CF (dB)	4.52	Included in Calculations of Corr'd PSD
---------------------------	------	---

Output Power Results

Channel	Frequency (MHz)	Chain 0 Meas Power (dBm)	Chain 1 Meas Power (dBm)	Total Corr'd EIRP (dBm)	Power Limit (dBm)	Power Margin (dB)
Low	6625	4.99	3.90	11.99	24.00	-12.01
Mid	6705	5.21	4.18	12.24	24.00	-11.76
High	6785	4.49	3.34	11.46	24.00	-12.54

PSD Results

Channel	Frequency (MHz)	Chain 0 Meas PSD (dBm)	Chain 1 Meas PSD (dBm)	Total Corr'd PSD (dBm)	PSD EIRP Limit (dBm)	PSD EIRP Margin (dB)
Low	6625	-16.63	-16.01	-1.57	-1.00	-0.57
Mid	6705	-16.57	-16.01	-1.55	-1.00	-0.55
High	6785	-16.95	-16.24	-1.85	-1.00	-0.85

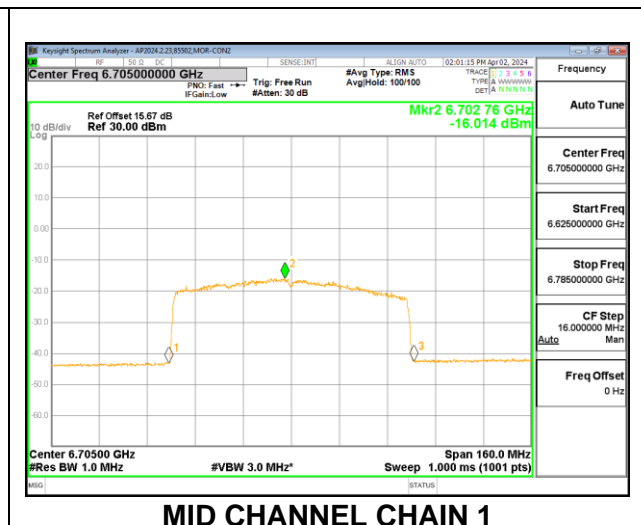
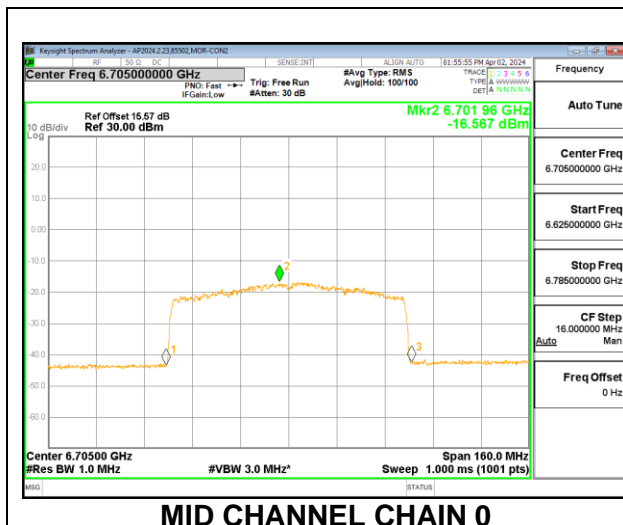

2TX CHAIN 0 + CHAIN 1 OFDMA MODE: SU

Test Engineer:	85502
Test Date:	2024/04/02

Bandwidth, Antenna Gain and Limits

Channel	Frequency (MHz)	Directional Gain for Power (dBi)	Directional Gain for PSD (dBi)	e.i.r.p. Power Limit (dBm)	PSD Limit (dBm)
Low	6625	4.50	7.20	24.00	-1.00
Mid	6705	4.50	7.20	24.00	-1.00
High	6785	4.50	7.20	24.00	-1.00

Duty Cycle CF (dB)	2.37	Included in Calculations of Corr'd PSD
---------------------------	------	---

Output Power Results

Channel	Frequency (MHz)	Chain 0 Meas Power (dBm)	Chain 1 Meas Power (dBm)	Total Corr'd EIRP (dBm)	Power Limit EIRP (dBm)	Power Margin (dB)
Low	6625	4.75	4.12	11.96	24.00	-12.04
Mid	6705	4.92	4.38	12.17	24.00	-11.83
High	6785	5.12	4.05	12.13	24.00	-11.87

PSD Results

Channel	Frequency (MHz)	Chain 0 Meas PSD (dBm)	Chain 1 Meas PSD (dBm)	Total Corr'd PSD (dBm)	PSD EIRP Limit (dBm)	PSD EIRP Margin (dB)
Low	6625	-14.49	-14.34	-1.83	-1.00	-0.83
Mid	6705	-14.90	-13.80	-1.74	-1.00	-0.74
High	6785	-15.09	-13.31	-1.53	-1.00	-0.53

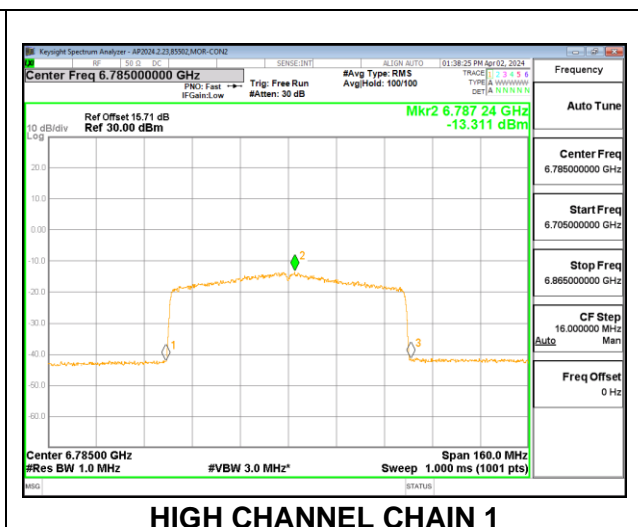
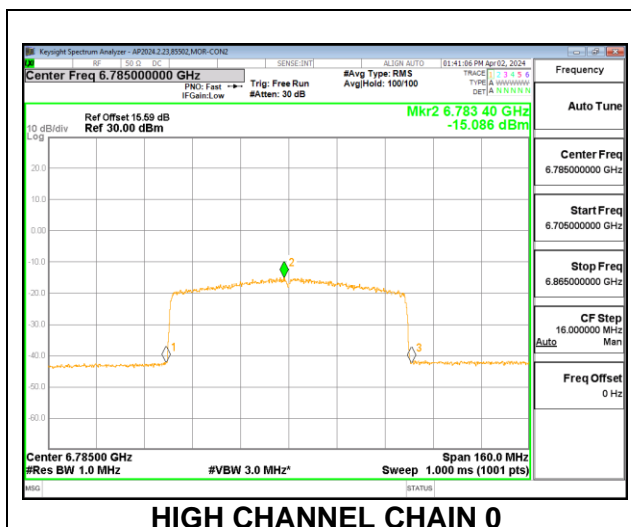

9.2.13. 802.11a MODE 2TX IN THE U-NII 8 BAND

2TX CHAIN 0 + CHAIN 1

Test Engineer:	85502
Test Date:	2024/04/02

Bandwidth, Antenna Gain and Limits

Channel	Frequency (MHz)	Directional Gain for Power (dBi)	Directional Gain for PSD (dBi)	e.i.r.p. Power Limit (dBm)	PSD Limit (dBm)
Low	6875	3.90	6.40	24.00	-1.00
Mid	6995	3.90	6.40	24.00	-1.00
High	7115	3.90	6.40	24.00	-1.00

Duty Cycle CF (dB)	0.94	Included in Calculations of Corr'd PSD
---------------------------	------	---

Output Power Results

Channel	Frequency (MHz)	Chain 0 Meas Power (dBm)	Chain 1 Meas Power (dBm)	Total Corr'd EIRP (dBm)	Power Limit EIRP (dBm)	Power Margin (dB)
Low	6875	-0.03	-0.01	6.89	24.00	-17.11
Mid	6995	0.93	-0.29	7.27	24.00	-16.73
High	7115	0.56	-0.58	6.94	24.00	-17.06

PSD Results

Channel	Frequency (MHz)	Chain 0 Meas PSD (dBm)	Chain 1 Meas PSD (dBm)	Total Corr'd PSD (dBm)	PSD EIRP Limit (dBm)	PSD EIRP Margin (dB)
Low	6875	-12.56	-11.27	-1.51	-1.00	-0.51
Mid	6995	-12.23	-11.72	-1.62	-1.00	-0.62
High	7115	-12.77	-11.21	-1.57	-1.00	-0.57

