

TEST REPORT

Report Number.: 14093500-E4V2

Applicant : SONOS INC.
614 CHAPALA ST.
SANTA BARBARA, CA, 93101, U.S.A.

Model : S41

Brand : SONOS

FCC ID : SBVRM041

IC : 5373A-RM041

EUT Description : 802.11 a/b/g/n/ac/ax 2x2 Client Device with BT and BLE

Test Standard(s) : FCC 47 CFR PART 15 SUBPART C
ISED RSS-247 ISSUE 2
ISED RSS-GEN ISSUE 5 + A1 + A2

Date Of Issue:

2022-10-24

Prepared by:

UL Verification Services Inc.
47173 Benicia Street
Fremont, CA 94538 U.S.A.
TEL: (510) 319-4000
FAX: (510) 661-0888



REPORT REVISION HISTORY

Rev.	Issue Date	Revisions	Revised By
V1	2022-10-13	Initial Issue	---
V2	2022-10-24	Updated Section 1 and 9	Kiya Kedida

TABLE OF CONTENTS

REPORT REVISION HISTORY	2
TABLE OF CONTENTS	3
1. ATTESTATION OF TEST RESULTS	5
2. TEST RESULTS SUMMARY	7
3. TEST METHODOLOGY	8
4. FACILITIES AND ACCREDITATION	8
5. DECISION RULES AND MEASUREMENT UNCERTAINTY	9
5.1. METROLOGICAL TRACEABILITY	9
5.2. DECISION RULES.....	9
5.3. MEASUREMENT UNCERTAINTY.....	9
5.4. SAMPLE CALCULATION	9
6. EQUIPMENT UNDER TEST	10
6.1. EUT DESCRIPTION	10
6.2. MAXIMUM OUTPUT POWER.....	10
6.3. DESCRIPTION OF AVAILABLE ANTENNAS	10
6.4. SOFTWARE AND FIRMWARE.....	10
6.5. TEST REDUCTION CASE.....	11
6.6. WORST-CASE CONFIGURATION AND MODE.....	11
6.7. DESCRIPTION OF TEST SETUP.....	12
7. MEASUREMENT METHOD.....	14
8. TEST AND MEASUREMENT EQUIPMENT	15
9. ANTENNA PORT TEST RESULTS	16
9.1. ON TIME AND DUTY CYCLE.....	16
9.2. 6 dB BANDWIDTH.....	18
9.2.1. 802.11ax HE20 MODE 2TX	19
9.2.2. 802.11ax HE40 MODE 2TX.....	23
9.3. 99% BANDWIDTH.....	27
9.3.1. 802.11ax HE20 MODE 2TX.....	28
9.3.2. 802.11ax HE40 MODE 2TX	32
9.4. OUTPUT POWER.....	36
9.4.1. 802.11ax HE20 MODE 2TX	39
9.4.2. 802.11ax HE40 MODE 2TX	42

9.5.	<i>AVERAGE POWER</i>	45
9.5.1.	802.11ax HE20 MODE 2TX.....	46
9.5.2.	802.11ax HE40 MODE 2TX.....	48
9.6.	<i>POWER SPECTRAL DENSITY</i>	50
9.6.1.	802.11ax HE20 MODE 2TX.....	50
9.6.2.	802.11ax HE40 MODE 2TX.....	55
9.7.	<i>CONDUCTED SPURIOUS EMISSIONS</i>	60
9.7.1.	802.11ax HE20 MODE 2TX.....	61
9.7.2.	802.11ax HE40 MODE 2TX.....	67
10.	RADIATED TEST RESULTS	73
10.1.	<i>TRANSMITTER ABOVE 1 GHz</i>	75
10.1.1.	TX ABOVE 1 GHz 802.11ax HE20 MODE IN THE 2.4GHz BAND.....	75
10.1.2.	TX ABOVE 1 GHz 802.11ax HE40 MODE IN THE 2.4GHz BAND.....	95
10.2.	<i>Worst Case Below 30MHz</i>	115
10.3.	<i>Worst Case Below 1 GHz</i>	116
10.4.	<i>Worst Case 18-26 GHz</i>	118
11.	AC POWER LINE CONDUCTED EMISSIONS	120
12.	SETUP PHOTOS	123

1. ATTESTATION OF TEST RESULTS

COMPANY NAME: SONOS INC.
614 Chapala St.
Santa Barbara, CA, 93101, U.S.A.

EUT DESCRIPTION: 802.11 a/b/g/n/ac/ax 2x2 Client Device with BT and BLE

MODEL: S41

BRAND: SONOS

SERIAL NUMBER: Radiated Sample: 000E580AD3058 and 000E583B70D08
Conducted Sample: 000E5893E2BB2

SAMPLE RECEIPT DATE: 2022-09-12

DATE TESTED: 2022-09-14 to 2022-10-06

APPLICABLE STANDARDS	
STANDARD	TEST RESULTS
CFR 47 Part 15 Subpart C	Complies
ISED RSS-247 Issue 2	Complies
ISED RSS-GEN Issue 5 + A1 + A2	Complies

UL Verification Services Inc. tested the above equipment in accordance with the requirements set forth in the above standards. The test results show that the equipment tested is capable of demonstrating compliance with the requirements as documented in this report.

The results documented in this report apply only to the tested sample, under the conditions and modes of operation as described herein. It is the manufacturer's responsibility to assure that additional production units of this model are manufactured with identical electrical and mechanical components. All samples tested were in good operating condition throughout the entire test program. Measurement Uncertainties are published for informational purposes only and were not taken into account unless noted otherwise.

This document may not be altered or revised in any way unless done so by UL Verification Services Inc. and all revisions are duly noted in the revisions section. Any alteration of this document not carried out by UL Verification Services Inc. will constitute fraud and shall nullify the document. This report must not be used by the client to claim product certification, approval, or endorsement by A2LA, NIST, any agency of the Federal Government, or any agency of the U.S. government.

Approved & Released For
UL Verification Services Inc. By:



Francisco de Anda
Staff Engineer
Consumer Technology Division
UL Verification Services Inc.

Prepared By:



Glenn Escano
Senior Test Engineer
Consumer Technology Division
UL Verification Services Inc.

1st Reviewed By:



Vien Tran
Senior Laboratory Engineer
Consumer Technology Division
UL Verification Services Inc.

2nd Reviewed By:



Kiya Kedida
Senior Project Engineer
Consumer Technology Division
UL Verification Services Inc.

2. TEST RESULTS SUMMARY

This report contains data provided by the customer which can impact the validity of results. UL Verification Services Inc. is only responsible for the validity of results after the integration of the data provided by the customer.

Below is a list of the data provided by the customer:

1. Antenna gain and type (see section 6.3)

FCC Clause	ISED Clause	Requirement	Result	Comment
See Comment		Duty Cycle	Reporting purposes only	ANSI C63.10 Section 11.6.
-	RSS-GEN 6.7	99% OBW	Reporting purposes only	ANSI C63.10 Section 6.9.3.
15.247 (a) (2)	RSS-247 5.2 (a)	6dB BW	Compliant	None.
15.247 (b) (3)	RSS-247 5.4 (d)	Output Power	Compliant	None.
See Comment		Average power	Reporting purposes only	Per ANSI C63.10, Section 11.9.2.3.2.
15.247 (e)	RSS-247 5.2 (b)	PSD	Compliant	None.
15.247 (d)	RSS-247 5.5	Conducted Spurious Emissions	Compliant	None.
15.209, 15.205	RSS-GEN 8.9, 8.10	Radiated Emissions	Compliant	None.
15.207	RSS-Gen 8.8	AC Mains Conducted Emissions	Compliant	None.

3. TEST METHODOLOGY

The tests documented in this report were performed in accordance with FCC CFR 47 Part 2, FCC CFR 47 Part 15, ANSI C63.10-2013, and KDB 558074 D01 15.247 Meas Guidance v05r02, KDB 414788 D01 Radiated Test Site v01r01, RSS-GEN Issue 5 + A1 + A2, and RSS-247 Issue 2.

4. FACILITIES AND ACCREDITATION

UL Verification Services Inc. is accredited by A2LA, Certificate Number #0751.05, for all testing performed within the scope of this report. Testing was performed at the locations noted below.

	Address	ISED CABID	ISED Company Number	FCC Registration
<input type="checkbox"/>	Building 1: 47173 Benicia Street Fremont, CA 94538, U.S.A	US0104	2324A	550739
<input type="checkbox"/>	Building 2: 47266 Benicia Street Fremont, CA 94538, U.S.A	US0104	22541	550739
<input checked="" type="checkbox"/>	Building 4: 47658 Kato Rd Fremont, CA 94538, U.S.A	US0104	2324B	550739

5. DECISION RULES AND MEASUREMENT UNCERTAINTY

5.1. METROLOGICAL TRACEABILITY

All test and measuring equipment utilized to perform the tests documented in this report are calibrated on a regular basis, with a maximum time between calibrations of one year or the manufacturers' recommendation, whichever is less, and where applicable is traceable to recognized national standards.

5.2. DECISION RULES

The Decision Rule is based on Simple Acceptance in accordance with ISO Guide 98-4:2012 Clause 8.2. (Measurement uncertainty is not taken into account when stating conformity with a specified requirement.)

5.3. MEASUREMENT UNCERTAINTY

Where relevant, the following measurement uncertainty levels have been estimated for tests performed on the apparatus:

PARAMETER	U _{Lab}
Worst Case Conducted Disturbance, 9KHz to 0.15 MHz	3.78 dB
Worst Case Conducted Disturbance, 0.15 to 30 MHz	3.40 dB
Worst Case Radiated Disturbance, 9KHz to 30 MHz	2.84 dB
Worst Case Radiated Disturbance, 30 to 1000 MHz	4.88 dB
Worst Case Radiated Disturbance, 1000 to 18000 MHz	4.73 dB
Worst Case Radiated Disturbance, 18000 to 26000 MHz	4.51 dB
Worst Case Radiated Disturbance, 26000 to 40000 MHz	5.29 dB

Uncertainty figures are valid to a confidence level of 95%.

5.4. SAMPLE CALCULATION

RADIATED EMISSIONS

Where relevant, the following sample calculation is provided:

$$\text{Field Strength (dBuV/m)} = \text{Measured Voltage (dBuV)} + \text{Antenna Factor (dB/m)} + \text{Cable Loss (dB)} - \text{Preamp Gain (dB)}$$

$$36.5 \text{ dBuV} + 18.7 \text{ dB/m} + 0.6 \text{ dB} - 26.9 \text{ dB} = 28.9 \text{ dBuV/m}$$

MAINS CONDUCTED EMISSIONS

Where relevant, the following sample calculation is provided:

$$\text{Final Voltage (dBuV)} = \text{Measured Voltage (dBuV)} + \text{Cable Loss (dB)} + \text{Limiter Factor (dB)} + \text{LISN Insertion Loss.}$$

$$36.5 \text{ dBuV} + 0 \text{ dB} + 10.1 \text{ dB} + 0 \text{ dB} = 46.6 \text{ dBuV}$$

6. EQUIPMENT UNDER TEST

6.1. EUT DESCRIPTION

The EUT is an 802.11 a/b/g/n/ac/ax 2x2 Client Device with BT and BLE.

This report covers ax 2.4GHz Wifi radio.

6.2. MAXIMUM OUTPUT POWER

The transmitter has a maximum conducted output power as follows:

2.4GHz BAND 802.11 ax MODE 2TX

Frequency Range (MHz)	Mode	Output Power (dBm)	Output Power (mW)
2TX CDD			
2412 - 2462	802.11ax HE20 SU	20.21	104.95
2412 - 2462	802.11ax HE20 RU size 242T	20.77	119.40
2412 - 2462	802.11ax HE20 RU size 26T	21.21	132.13
2422 - 2452	802.11ax HE40 SU	22.67	184.93
2422 - 2452	802.11ax HE40 RU size 484T	22.88	194.09
2422 - 2452	802.11ax HE40 RU size 26T	20.60	114.82

6.3. DESCRIPTION OF AVAILABLE ANTENNAS

The antenna gains and type, as provided by the manufacturer are as follows:

The radio utilizes PCB antennas, with maximum gains as follows:

Frequency Range (MHz)	Peak Antenna Gain (dBi)			
	Chain 0		Chain 1	
	ANT1 (FR) (dBi)	ANT2 (RL) (dBi)	ANT3 (RR) (dBi)	ANT4 (FL) (dBi)
2412-2472	4.4	2.1	3.4	3.1

6.4. SOFTWARE AND FIRMWARE

The EUT firmware installed during testing was 70.1-29190-diag.

The test utility software used during testing was GUI_V8.

6.5. TEST REDUCTION CASE

After investigation, the output power of single user (SU) was lower than RU size 242 tone and 26 tone. Therefore, the SU was omitted from the testing. See Maximum Output Power section.

6.6. WORST-CASE CONFIGURATION AND MODE

Radiated emissions below 1GHz, above 18GHz, and power line conducted emission were performed with the EUT set to transmit at the channel with highest output power as worst-case scenario.

Band edge and radiated emissions between 1GHz and 18GHz were performed with the EUT set to transmit at the highest power on low, middle, and high channels.

The EUT can only be setup in desktop orientation; therefore, all radiated testing was performed with the EUT in desktop orientation.

The fundamental of the EUT was investigated in the antenna combinations, it was determined that Antenna 1 and Antenna 3 was the worst case; therefore, all final radiated testing was performed with Antenna 1 and Antenna 3.

Worst-case data rates as provided by the manufacturer were:

802.11ax HE20mode: MCS0
802.11ax HE40mode: MCS0

Preliminary Investigation were performed for 802.11ax modes were determined by the following:

- Testing was performed on 802.11ax HE20 26T(Lowest Tones) and 242T (Full Tone) to cover HE20 52T and 106T.
- Testing was performed on 802.11ax HE40 26T (Lowest Tones) and 484T(Full Tone) to cover HE40 52T,106T and 242T.

Also, Preliminary investigation conducted power were performed to compare Full RU Tone modes and SU (Single User) Tone modes. It was determined that Full RU Tone modes were worst case over Single User mode in every instance. Therefore, only full tone modes were tested and represents SU mode as worst case scenario.

6.7. DESCRIPTION OF TEST SETUP

SUPPORT TEST EQUIPMENT						
Description	Manufacturer	Model	Serial Number	FCC ID/ DoC		
Laptop	Lenovo	T460s	PC0JMBF8	Doc		
Laptop AC/DC Adapter	Lenovo	ADLX90NLC2A	11S45N0247Z1ZSHH448JEY	Doc		
USB-A to Ethernet Adapter	Plugable	USB2-E100	8CAE4CE46AFA	Doc		
USB-C to USB-A Female Adapter	Amazon Basics	L6LUC160-CS-R	N/A	Doc		
I/O CABLES (CONDUCTED TEST)						
Cable No.	Port	# of Identical Ports	Connector Type	Cable Type	Cable Length (m)	Remarks
1	AC	3	AC	Un-shielded	1.25	AC Mains to EUT/Spectrum Analyzer/AC/DC Adapter
2	DC	1	DC	Un-shielded	1	AC/DC Adapter to Laptop
3	Ethernet	1	RJ45	Un-shielded	1.5	Laptop to USB Ethernet Adapter
4	USB-A	1	USB-A	Shielded	0.05	USB EthernetAdapter to USB
5	USB-C	1	USB-C	Shielded	0.05	EUT to USB-C/USB-A Female Adapter
6	SMA Cable	1	SMA	Un-Shielded	0.1	EUT to Spectrum Analyzer
I/O CABLES (RADIATED TEST)						
Cable No.	Port	# of Identical Ports	Connector Type	Cable Type	Cable Length (m)	Remarks
1	AC	3	AC	Un-shielded	1.25	AC Mains to EUT/Spectrum Analyzer/AC/DC Adapter
2	DC	1	DC	Un-shielded	1	AC/DC Adapter to Laptop
3	Ethernet	1	RJ45	Un-shielded	10	Laptop to USB Ethernet Adapter
4	USB-A	1	USB-A	Shielded	0.05	USB EthernetAdapter to USB
5	USB-C	1	USB-C	Shielded	0.05	EUT to USB-C/USB-A Female Adapter
6	SMA Cable	1	SMA	Un-Shielded	10	EUT to Horn Antenna

TEST SETUP

The EUT is a stand-alone unit, and the radio is exercised remotely by Sonos Compliance GUI test utility software via ethernet.

SETUP DIAGRAM

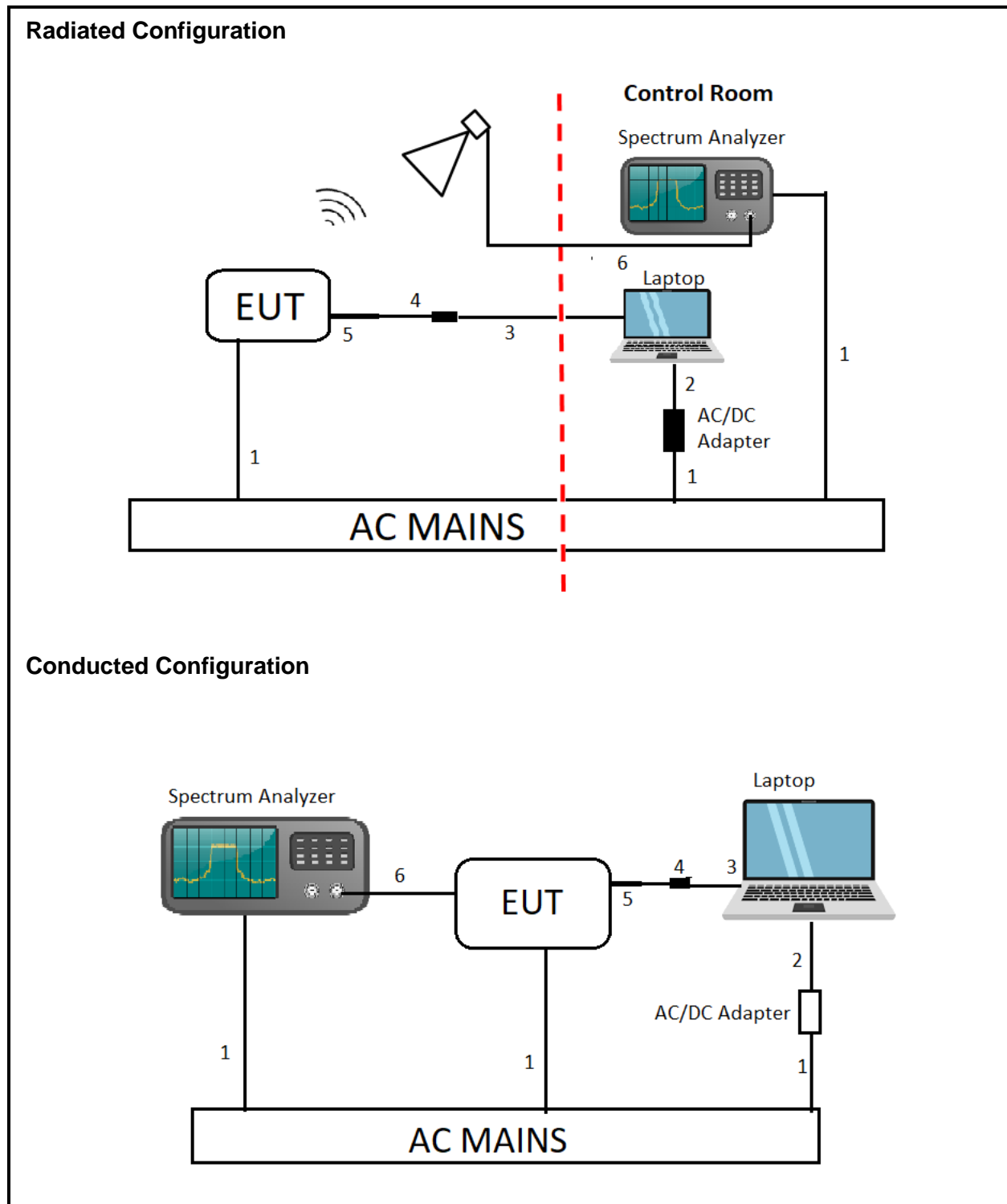

7. MEASUREMENT METHOD

On Time and Duty Cycle: ANSI C63.10 Section 11.6.

Occupied BW (99%): ANSI C63.10-2013 Section 6.9.3

6 dB BW: ANSI C63.10 Subclause -11.8.1 RBW \geq DTS BW

Output Power: ANSI C63.10 Subclause -11.9.2.3.2 Method PKPM1 Peak-reading power meter

PSD: ANSI C63.10 Subclause -11.10.2 Method PKPSD (peak PSD)

Radiated emissions non-restricted frequency bands: ANSI C63.10 Subclause -11.11

Radiated emissions restricted frequency bands: ANSI C63.10 Subclause -11.12.1

Conducted emissions in restricted frequency bands: ANSI C63.10 Subclause -11.12.2

<u>Band-edge:</u> ANSI C63.10 Subclause -11.13.3.2	Integration method -Peak detection
<u>Band-edge:</u> ANSI C63.10 Subclause -11.13.3.3	Integration method -Trace averaging with continuous transmission at full power
<u>Band-edge:</u> ANSI C63.10 Subclause -11.13.3.4	Integration method -Trace averaging across ON and OFF times DC correction

AC Power Line Conducted Emissions: ANSI C63.10-2013, Section 6.2.

Radiated Spurious Emissions Below 30MHz: ANSI C63.10-2013 Section 6.4

8. TEST AND MEASUREMENT EQUIPMENT

The following test and measurement equipment was utilized for the tests documented in this report:

TEST EQUIPMENT LIST					
Description	Manufacturer	Model	ID Num	Cal Due	Last Cal
Antenna, Broadband Hybrid, 30MHz to 3GHz	Sunol Sciences Corp.	JB3	171862	*2022-09-28	*2021-09-28
Amplifier, 10KHz to 1GHz, 32dB	SONOMA INSTRUMENT	310N	29654	2023-04-24	2022-04-24
Antenna, Horn 1-18GHz	ETS-Lindgren (Cedar Park, Texas)	3117	80707	2023-04-28	2022-04-28
RF Filter Box, 1-18GHz	FREMONT	SAC-L1	171013	2023-03-09	2022-03-09
EMI TEST RECEIVER, with B8 option	Rohde & Schwarz	ESW44	169937	2023-02-20	2022-02-20
EMI TEST RECEIVER	Rohde & Schwarz	ESW44	169927	2023-02-13	2022-02-13
Antenna, Horn 18 to 26.5GHz	ARA	MWH-1826/B	81138	2022-10-13	2021-10-13
Amplifier 18-26.5GHz, +5Vdc, 60dB min	AMPLICAL	AMP18G26.5-60	215705	2023-02-26	2022-02-26
Antenna, Passive Loop 30Hz - 1MHz	ELECTRO METRICS	EM-6871	219909	2023-05-10	2022-05-10
Antenna, Passive Loop 100KHz - 30MHz	ELECTRO METRICS	EM-6872	219911	2023-05-10	2022-05-10
Spectrum Analyzer, PXA, 3Hz to 44GHz	Agilent Technologies	N9030A	80396	2023-01-02	2022-01-02
Power Meter, P-series single channel	Keysight Technologies Inc	N1911A	T1268	2023-02-03	2022-02-03
Power Sensor, P - series, 50MHz to 18GHz, Wideband	Keysight Technologies Inc	N1921A	90419	2023-03-02	2022-03-02
AC Line Conducted					
LISN	Fischer Custom Communications, Inc	FCC-LISN-50/250-25-2-01-480V	175765	2023-01-26	2022-01-26
EMI TEST RECEIVER	Rohde & Schwarz	ESR	93091	2023-02-21	2022-02-21
Transient Limiter	Com-Power	LIT-930	127455	2023-02-02	2022-02-02
UL TEST SOFTWARE LIST					
Radiated Software	UL	UL EMC	Ver 2016-05-11, 2015-12-29, 2019-10-09, 2021-12-07, 2022-05-18, and 2022-07-06		
Antenna Port Software	UL	UL RF	Ver 2022.8.16		
AC Line Conducted Software	UL	UL EMC	Rev 9.5, 2022-02-17		

*Test performed before calibration expired.

9. ANTENNA PORT TEST RESULTS

9.1. ON TIME AND DUTY CYCLE

LIMITS

None; for reporting purposes only.

PROCEDURE

KDB 558074 D01 Zero-Span Spectrum Analyzer Method.

ON TIME AND DUTY CYCLE RESULTS

Mode	ON Time B (msec)	Period (msec)	Duty Cycle x (linear)	Duty Cycle (%)	Duty Cycle Correction Factor (dB)	1/B Minimum VBW (kHz)
2.4GHz Band						
802.11ax HE20 OFDMA, RU size 242T	0.377	0.980	0.385	38.50	4.15	2.650
802.11ax HE20 OFDMA, RU size 26T	0.580	1.166	0.497	49.70	3.04	1.725
802.11ax HE40 OFDMA, RU size 484T	0.368	0.970	0.379	37.89	4.22	2.721
802.11ax HE40 OFDMA, RU size 26T	0.581	1.192	0.487	48.70	3.12	1.723

DUTY CYCLE PLOTS



08:58:08 20.09.2022
802.11ax HE20 OFDMA, RU index 242T MODE



08:59:32 20.09.2022
802.11ax HE20 OFDMA, RU index 26T MODE



13:09:29 20.09.2022
802.11ax HE40 OFDMA, RU index 484T MODE

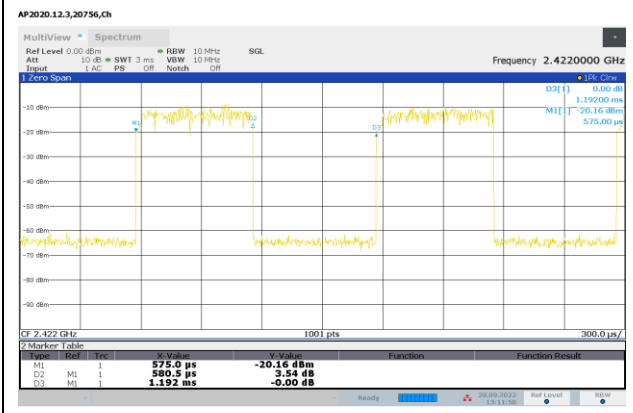

13:11:50 20.09.2022
802.11ax HE40 OFDMA, RU index 26T MODE



13:09:29 20.09.2022
802.11ax HE40 OFDMA, RU index 484T MODE



13:11:50 20.09.2022
802.11ax HE40 OFDMA, RU index 26T MODE

9.2. 6 dB BANDWIDTH

LIMITS

FCC §15.247 (a) (2)

ISED RSS-247 Clause 5.2 (a)

The minimum 6 dB bandwidth shall be at least 500 kHz.

RESULTS

9.2.1. 802.11ax HE20 MODE 2TX

2TX Antenna 1 + Antenna 3 CDD OFDMA MODE: 26-Tones, RU Index 0

Channel	Frequency (MHz)	6 dB BW Antenna 1 (MHz)	6 dB BW Antenna 3 (MHz)	Minimum Limit (MHz)
Low 1	2412	2.20	2.16	0.5

LOW CHANNEL 1

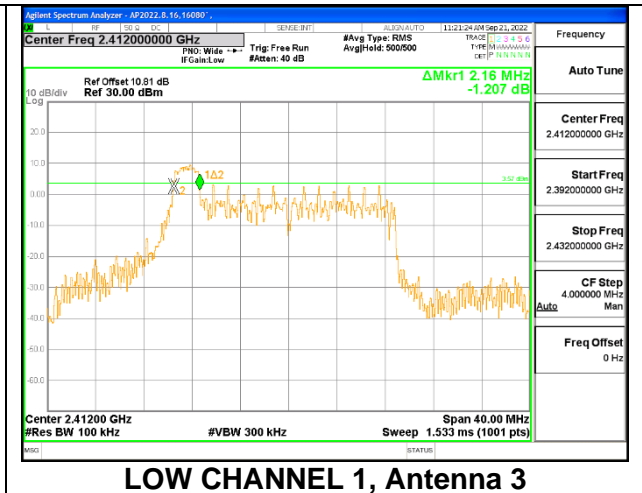
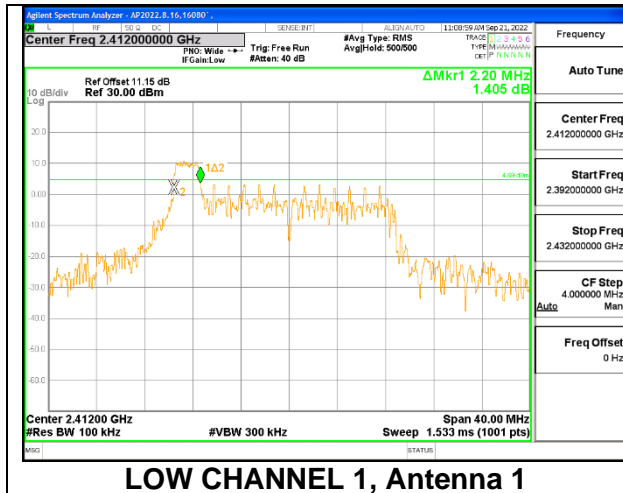

2TX Antenna 1 + Antenna 3 CDD OFDMA MODE: 26-Tones, RU Index 4

Channel	Frequency (MHz)	6 dB BW Antenna 1 (MHz)	6 dB BW Antenna 3 (MHz)	Minimum Limit (MHz)
Mid 6	2437	2.76	2.76	0.5

MID CHANNEL 6

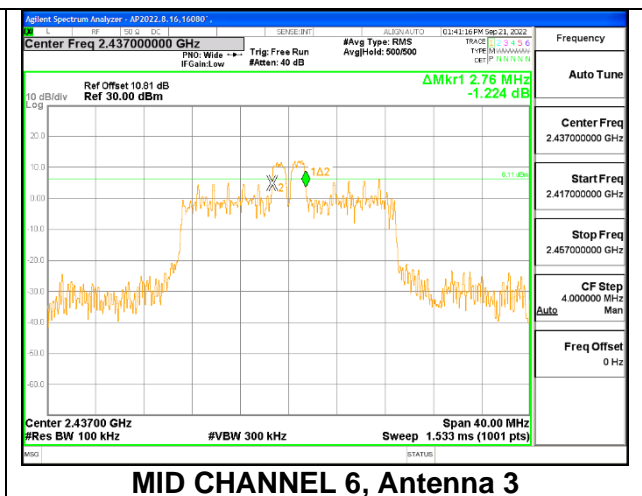
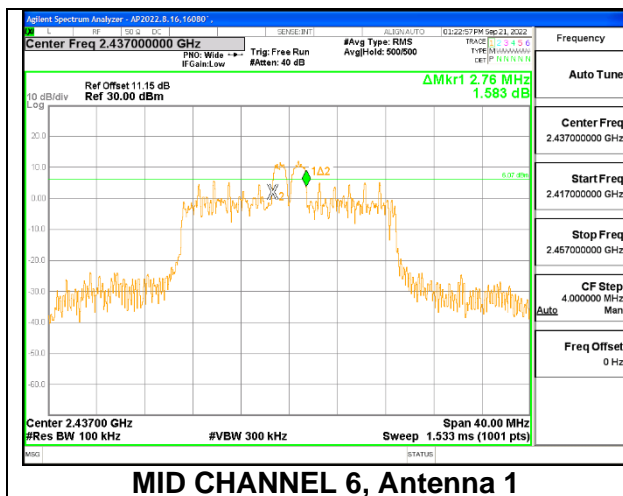

2TX Antenna 1 + Antenna 3 CDD OFDMA MODE: 26-Tones, RU Index 8

Channel	Frequency (MHz)	6 dB BW Antenna 1 (MHz)	6 dB BW Antenna 3 (MHz)	Minimum Limit (MHz)
High 11	2462	2.20	2.20	0.5

HIGH CHANNEL 11

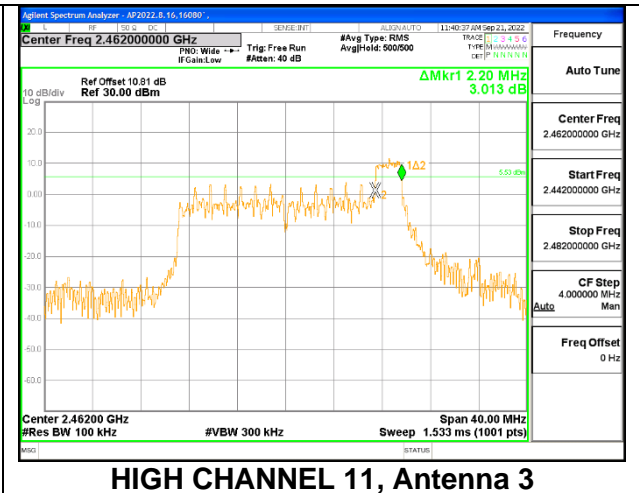
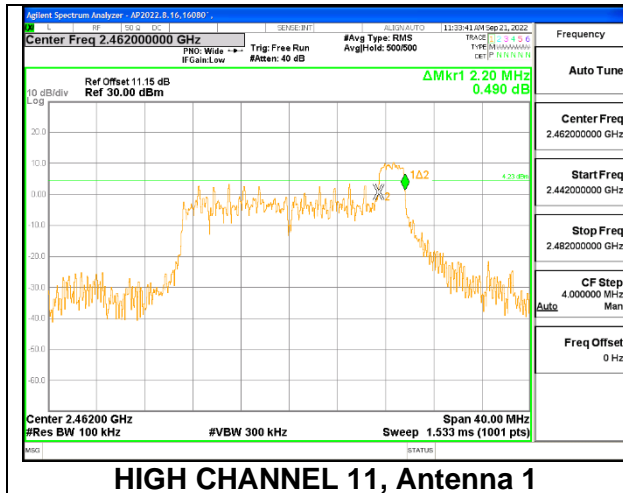

2TX Antenna 1 + Antenna 3 CDD OFDMA MODE: 242-Tones, RU Index 61

Channel	Frequency (MHz)	6 dB BW Antenna 1 (MHz)	6 dB BW Antenna 3 (MHz)	Minimum Limit (MHz)
Low 1	2412	18.48	18.72	0.5
Mid 6	2437	18.40	18.76	0.5
High 11	2462	18.68	18.88	0.5

LOW CHANNEL 1

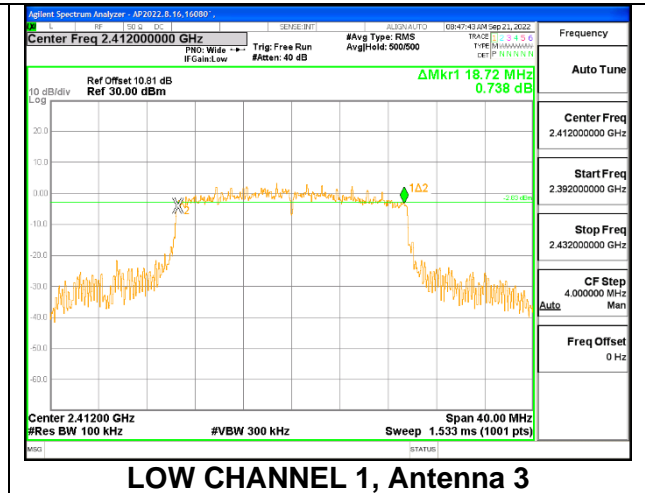
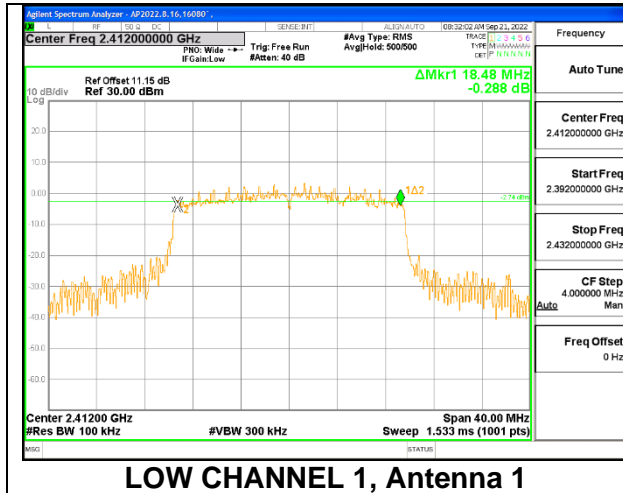

MID CHANNEL 6

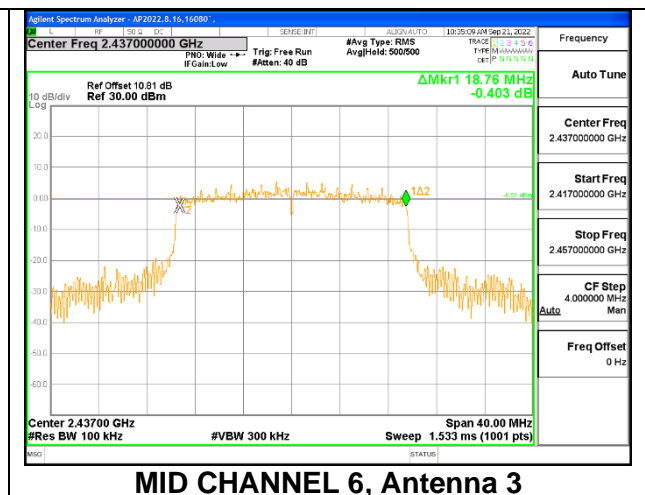
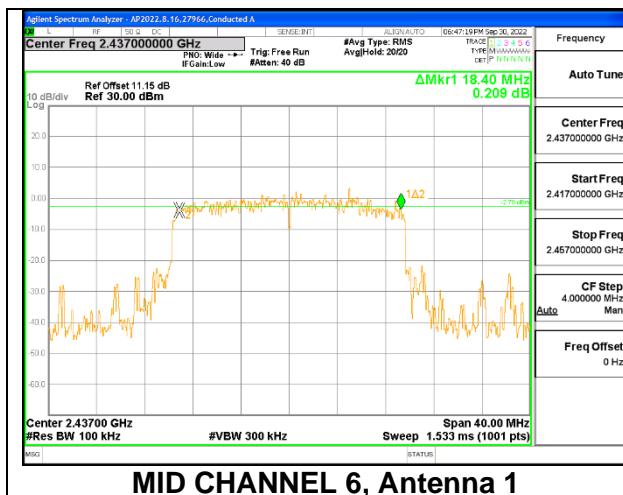

HIGH CHANNEL 11

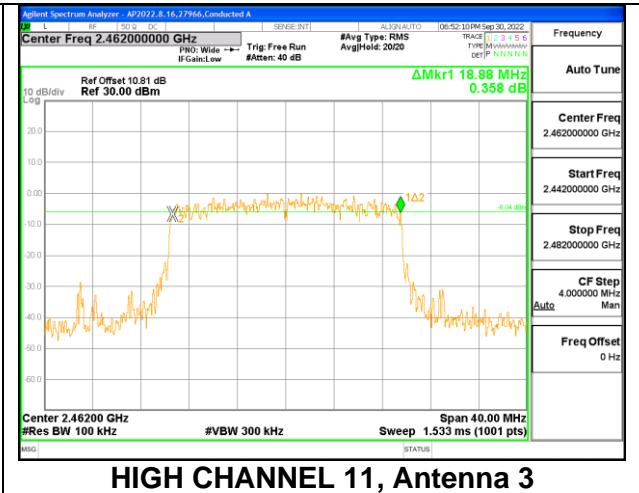
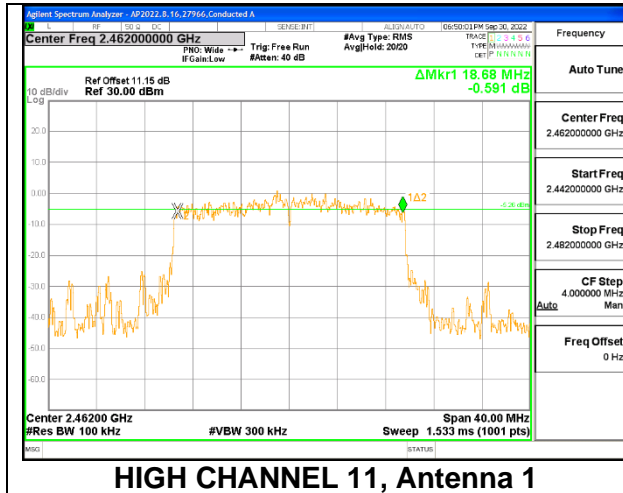

9.2.2. 802.11ax HE40 MODE 2TX

2TX Antenna 1 + Antenna 3 CDD OFDMA MODE: 26-Tones, RU Index 0

Channel	Frequency (MHz)	6 dB BW Antenna 1 (MHz)	6 dB BW Antenna 3 (MHz)	Minimum Limit (MHz)
Low 3	2422	2.24	2.32	0.5

LOW CHANNEL 3

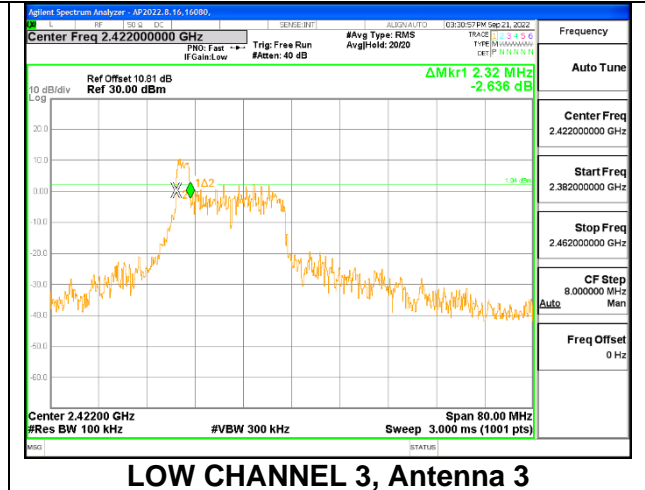
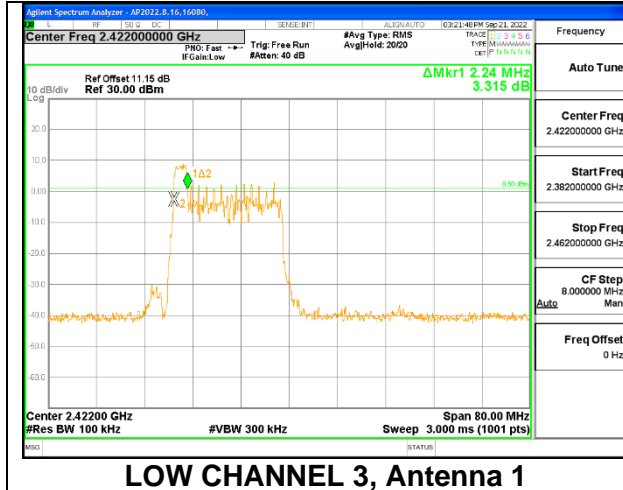

2TX Antenna 1 + Antenna 3 CDD OFDMA MODE: 26-Tones, RU Index 8

Channel	Frequency (MHz)	6 dB BW Antenna 1 (MHz)	6 dB BW Antenna 3 (MHz)	Minimum Limit (MHz)
Mid 6	2437	2.48	2.32	0.5

MID CHANNEL 6

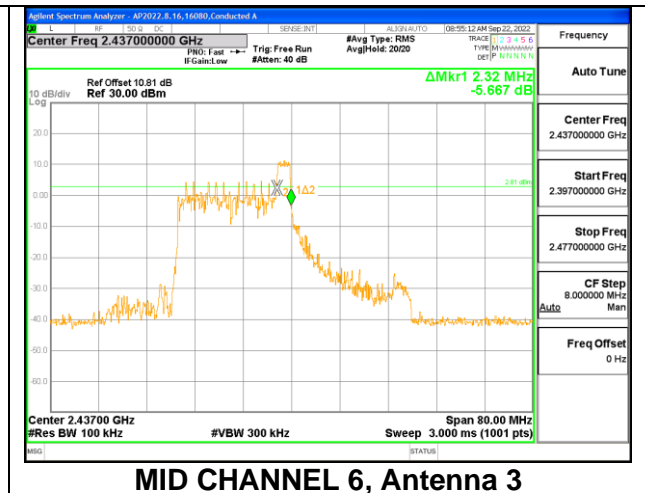
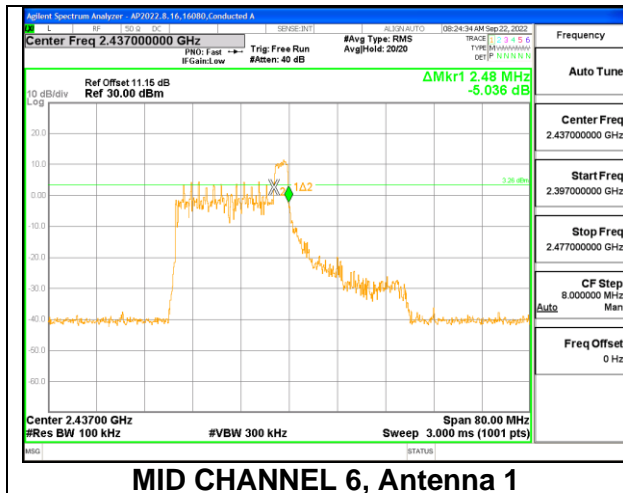

2TX Antenna 1 + Antenna 3 CDD OFDMA MODE: 26-Tones, RU Index 17

Channel	Frequency (MHz)	6 dB BW Antenna 1 (MHz)	6 dB BW Antenna 3 (MHz)	Minimum Limit (MHz)
High 9	2452	2.32	2.32	0.5

HIGH CHANNEL 9

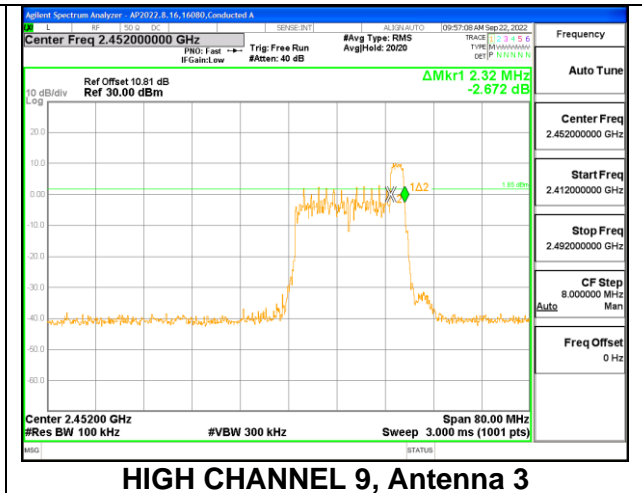
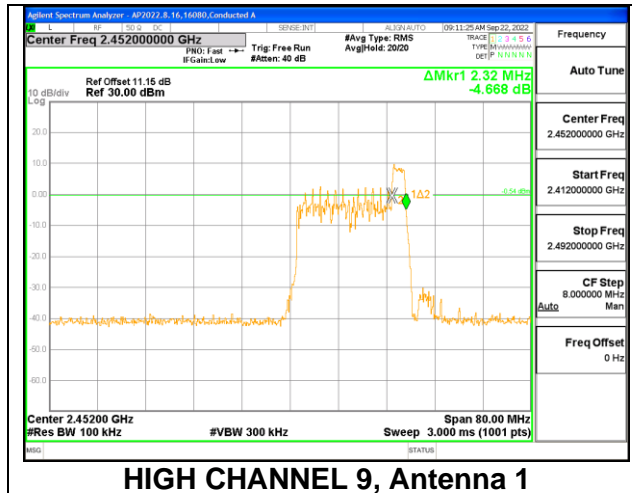

2TX Antenna 1 + Antenna 3 CDD OFDMA MODE: 484-Tones, RU Index 65

Channel	Frequency (MHz)	6 dB BW Antenna 1 (MHz)	6 dB BW Antenna 3 (MHz)	Minimum Limit (MHz)
Low 3	2422	37.84	37.92	0.5
Mid 6	2437	37.92	38.00	0.5
High 9	2452	37.68	37.76	0.5

LOW CHANNEL 3

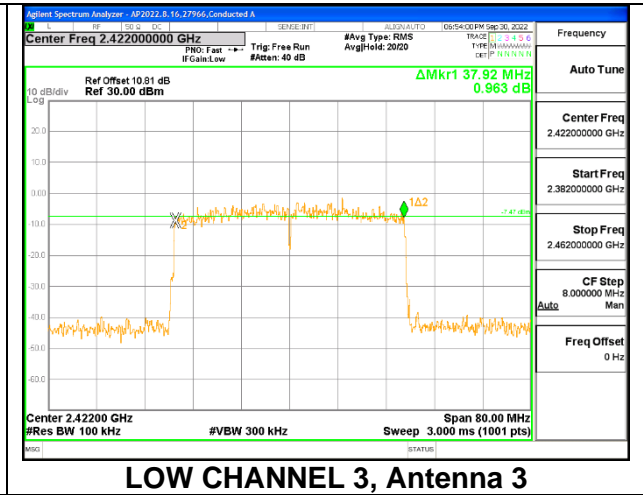
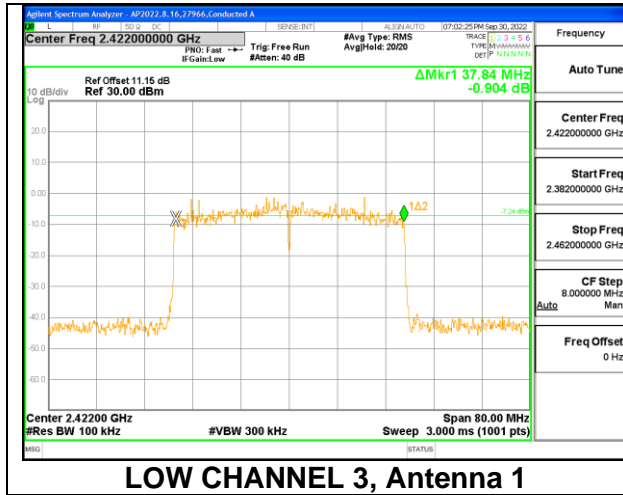

MID CHANNEL 6

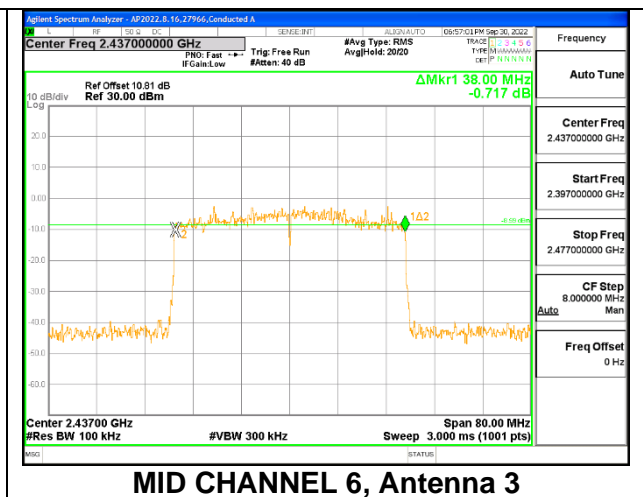
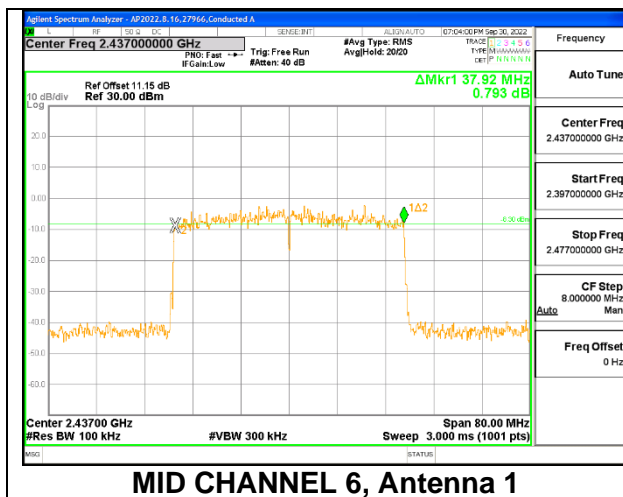

9.3. 99% BANDWIDTH

LIMITS

None; for reporting purposes only.

RESULTS

9.3.1. 802.11ax HE20 MODE 2TX

2TX Antenna 1 + Antenna 3 CDD OFDMA MODE: 26-Tones, RU Index 0

Channel	Frequency (MHz)	99% Bandwidth Antenna 1 (MHz)	99% Bandwidth Antenna 3 (MHz)
Low 1	2412	18.683	18.772

LOW CHANNEL 1

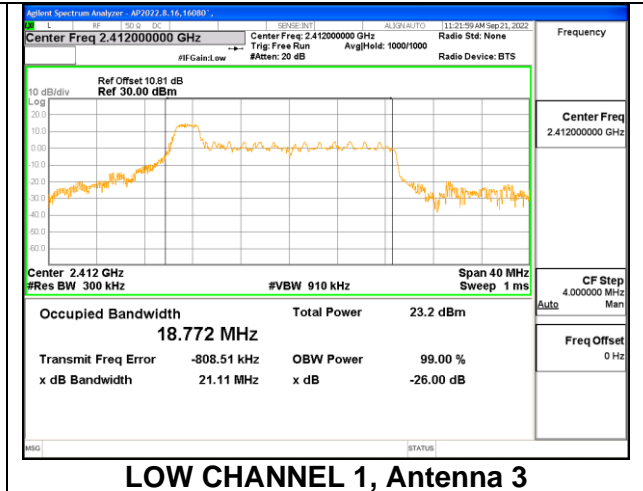
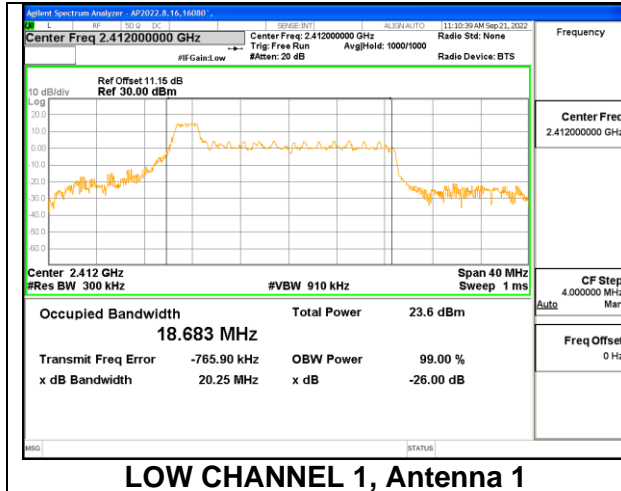

2TX Antenna 1 + Antenna 3 CDD OFDMA MODE: 26-Tones, RU Index 4

Channel	Frequency (MHz)	99% Bandwidth Antenna 1 (MHz)	99% Bandwidth Antenna 3 (MHz)
Mid 6	2437	17.114	17.085

MID CHANNEL 6

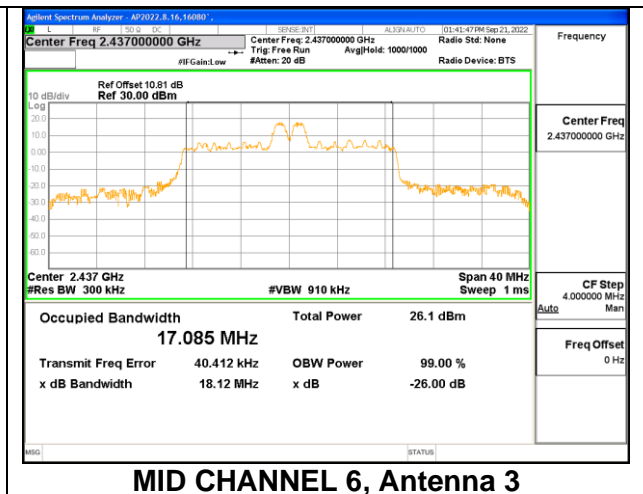
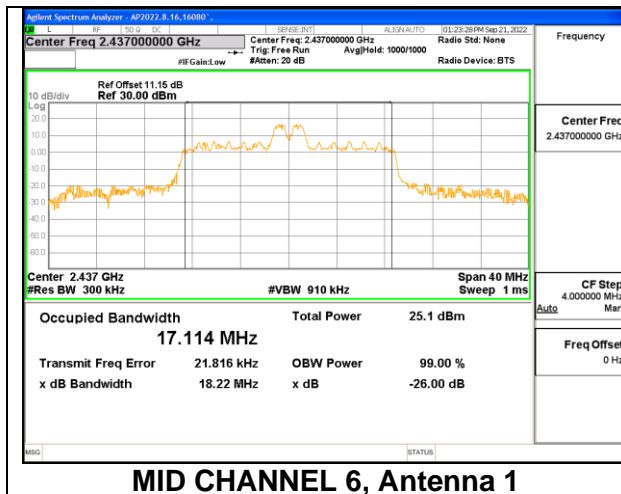

2TX Antenna 1 + Antenna 3 CDD OFDMA MODE: 26-Tones, RU Index 8

Channel	Frequency (MHz)	99% Bandwidth Antenna 1 (MHz)	99% Bandwidth Antenna 3 (MHz)
High 11	2462	18.802	18.627

HIGH CHANNEL 11

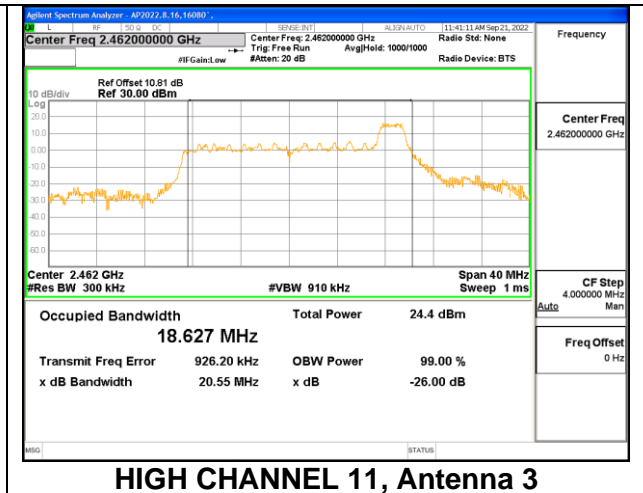
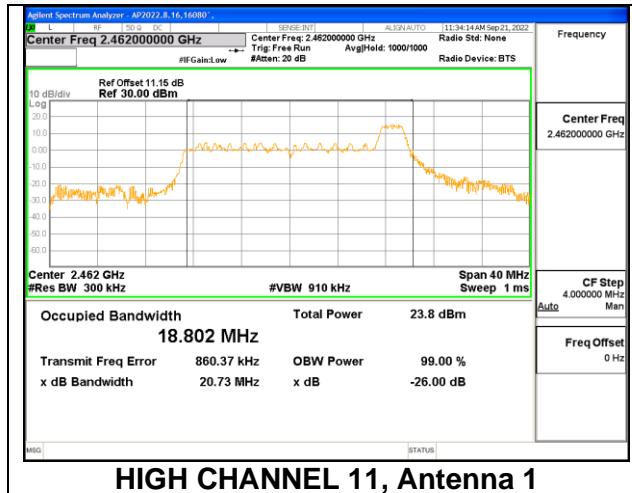

2TX Antenna 1 + Antenna 3 CDD OFDMA MODE: 242-Tones, RU Index 61

Channel	Frequency (MHz)	99% Bandwidth Antenna 1 (MHz)	99% Bandwidth Antenna 3 (MHz)
Low 1	2412	18.902	18.909
Mid 6	2437	18.916	18.946
High 11	2462	18.924	18.954

LOW CHANNEL 1

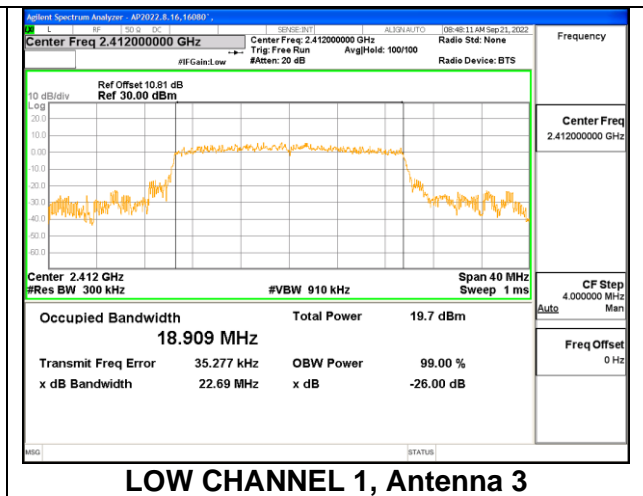
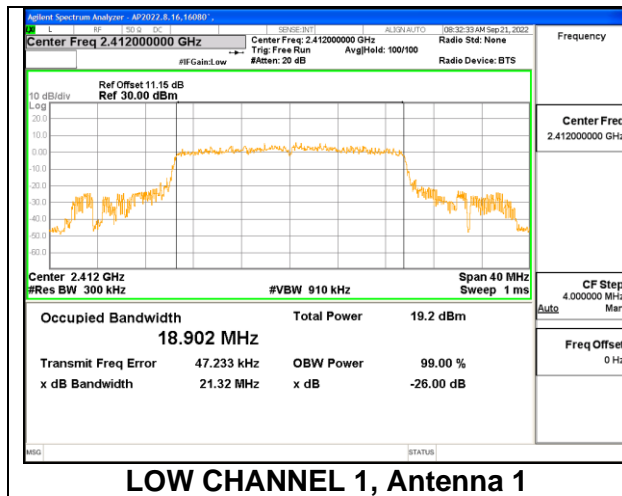

MID CHANNEL 6

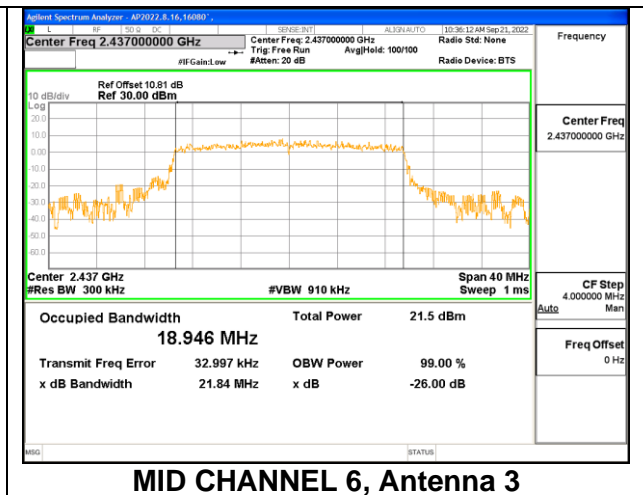
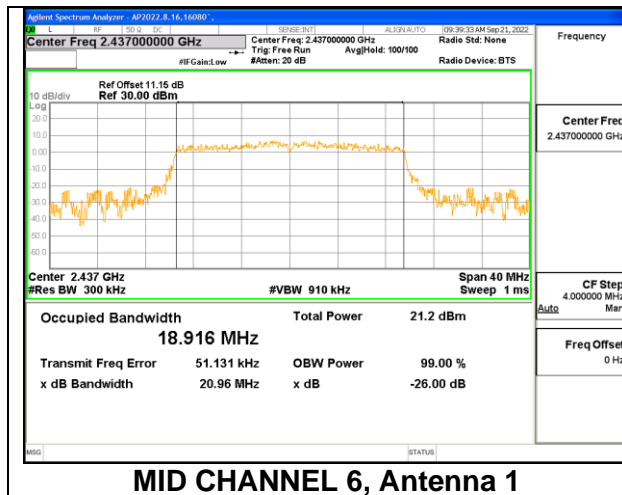

HIGH CHANNEL 11

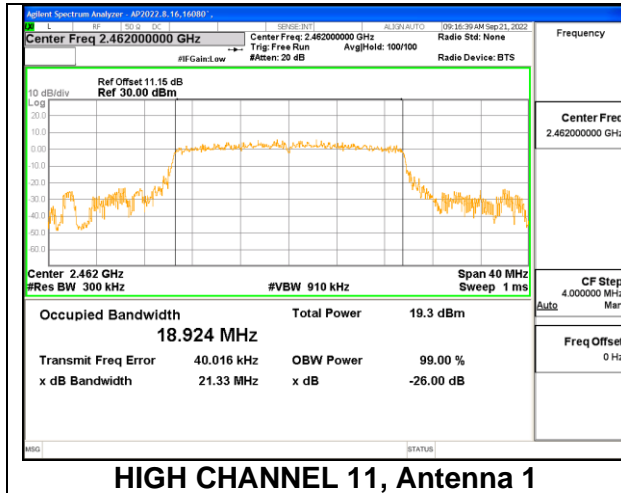

HIGH CHANNEL 11, Antenna 1

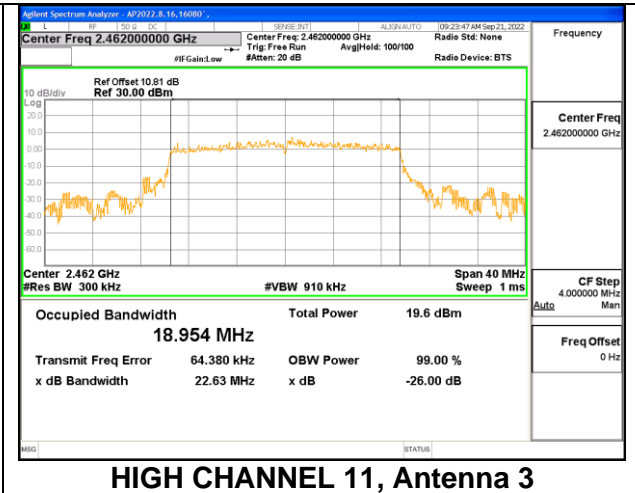

HIGH CHANNEL 11, Antenna 3

9.3.2. 802.11ax HE40 MODE 2TX

2TX Antenna 1 + Antenna 3 CDD OFDMA MODE: 26-Tones, RU Index 0

Channel	Frequency (MHz)	99% Bandwidth Antenna 1 (MHz)	99% Bandwidth Antenna 3 (MHz)
Low 3	2422	17.948	17.948

LOW CHANNEL 3

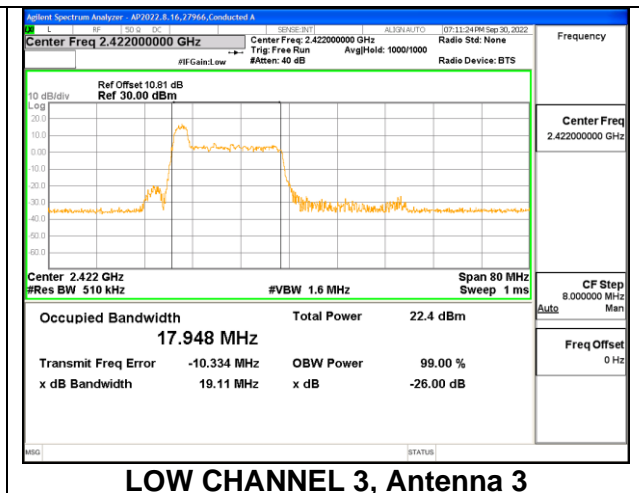
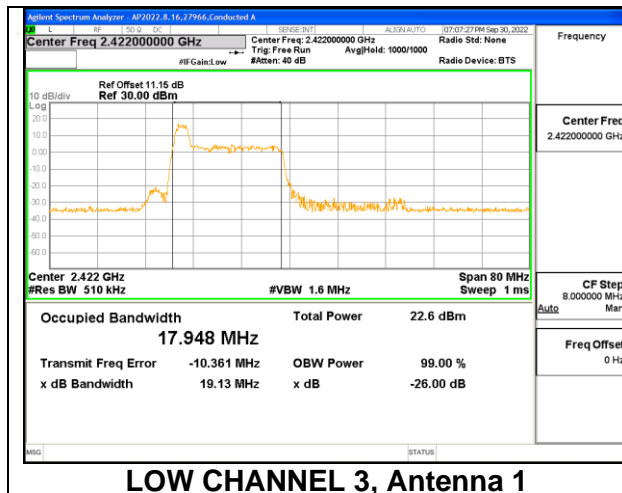

2TX Antenna 1 + Antenna 3 CDD OFDMA MODE: 26-Tones, RU Index 8

Channel	Frequency (MHz)	99% Bandwidth Antenna 1 (MHz)	99% Bandwidth Antenna 3 (MHz)
Mid 6	2437	20.170	20.230

MID CHANNEL 6

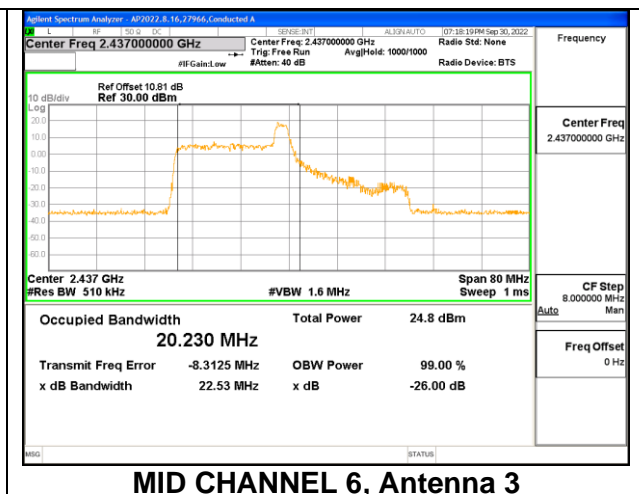
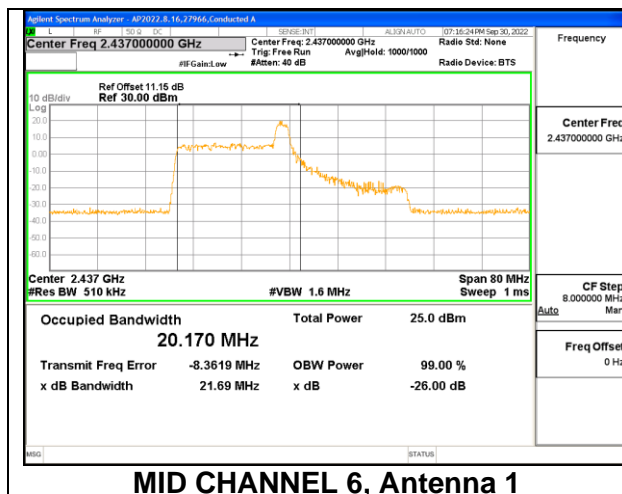

2TX Antenna 1 + Antenna 3 CDD OFDMA MODE: 26-Tones, RU Index 17

Channel	Frequency (MHz)	99% Bandwidth Antenna 1 (MHz)	99% Bandwidth Antenna 3 (MHz)
High 9	2452	17.898	17.869

HIGH CHANNEL 9

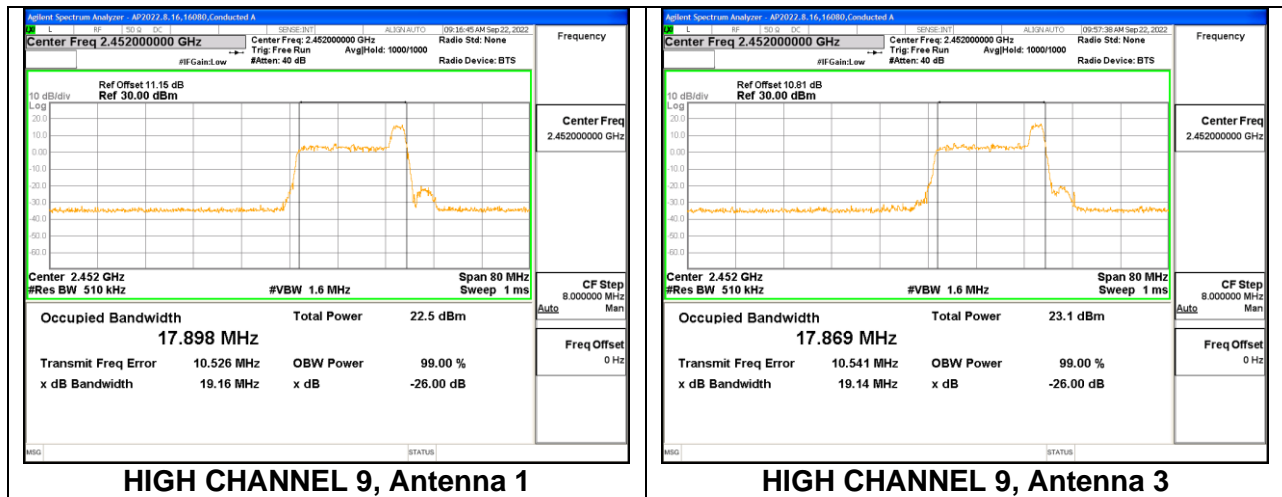

2TX Antenna 1 + Antenna 3 CDD OFDMA MODE: 484-Tones, RU Index 65

Channel	Frequency (MHz)	99% Bandwidth Antenna 1 (MHz)	99% Bandwidth Antenna 3 (MHz)
Low 3	2422	37.609	37.644
Mid 6	2437	37.679	37.572
High 9	2452	37.575	37.641

LOW CHANNEL 3

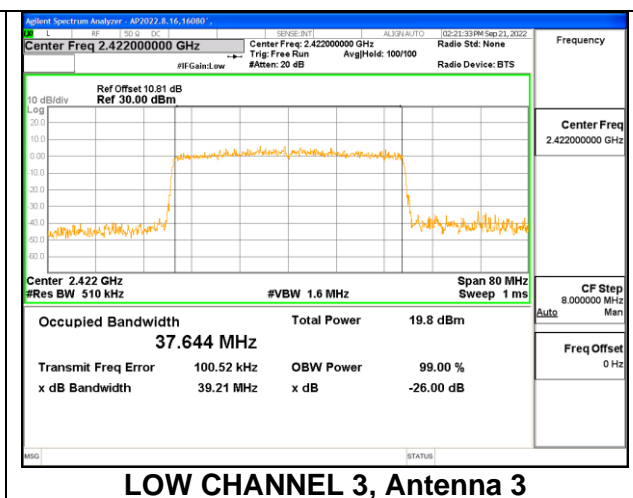
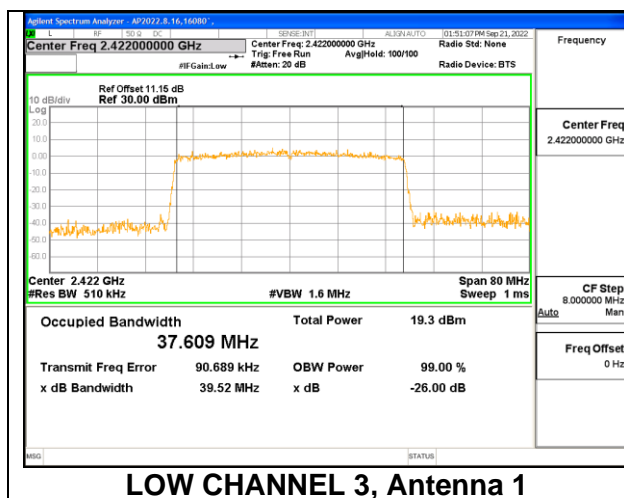

MID CHANNEL 6

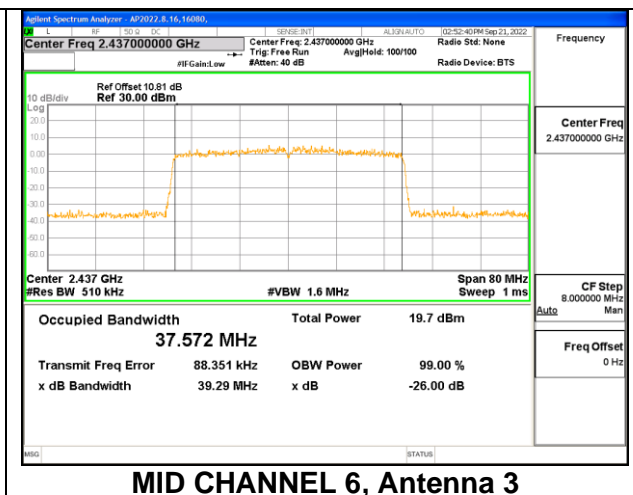
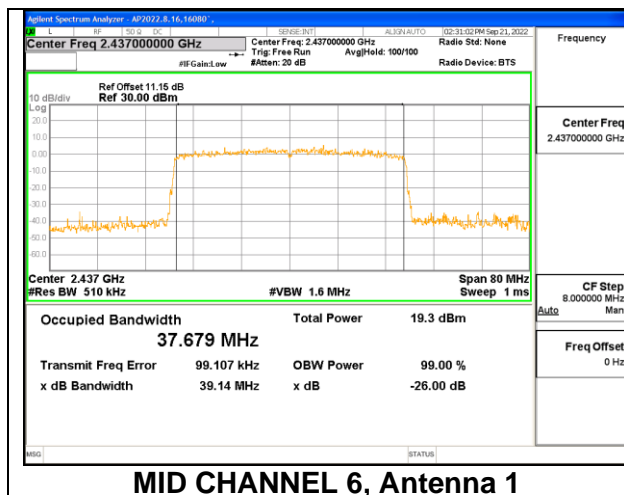

HIGH CHANNEL 9

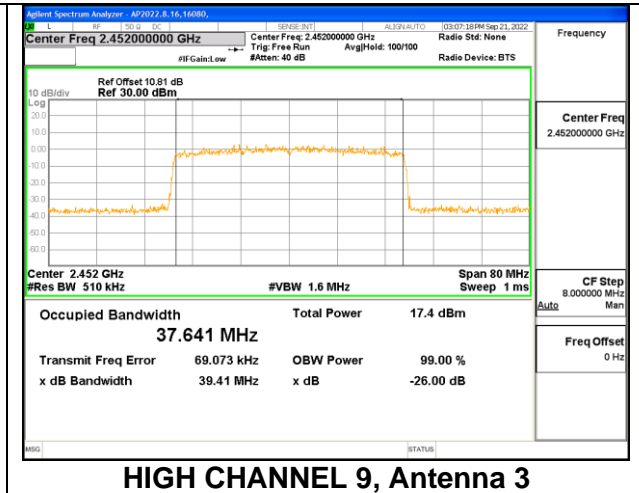
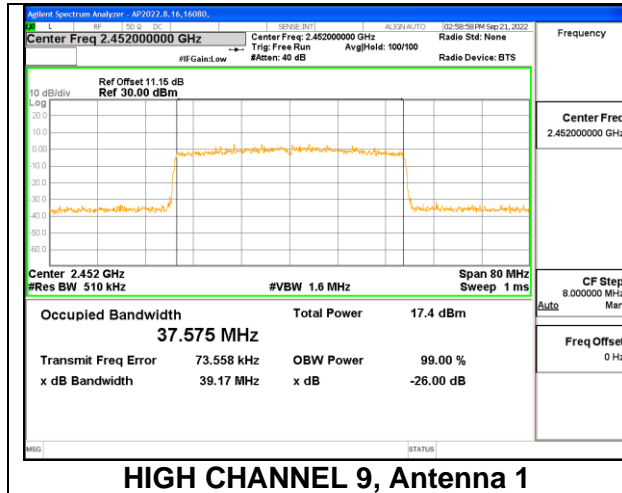

9.4. OUTPUT POWER

LIMITS

FCC §15.247 (b) (3)

RSS-247 5.4 (d)

For systems using digital modulation in the 902–928 MHz, 2400–2483.5 MHz, and 5725–5850 MHz bands: 1 Watt, based on the use of antennas with directional gains that do not exceed 6 dBi. If transmitting antennas of directional gain greater than 6 dBi are used, the conducted output power from the intentional radiator shall be reduced by the amount in dB that the directional gain of the antenna exceeds 6 dBi.

TEST PROCEDURE

The transmitter output is connected to a power meter.

The power output was measured on the EUT antenna port using SMA cable with 10dB attenuator connected to a power meter via power sensor. Peak output power was read directly from power meter.

DIRECTIONAL ANTENNA GAIN

For 2TX:

Tx chains are uncorrelated for power and correlated for PSD due to the device supporting CDD in all MIMO modes. The directional gains are as follows:

NOTE: Antenna 1 and Antenna 3 are the worst-case combinations.

Antenna 1 and Antenna 3 (Worst-case):

Band (GHz)	Chain 0 Antenna 1 Gain (dBi)	Chain 1 Antenna 3 Gain (dBi)	Uncorrelated Chains Directional Gain (dBi)	Correlated Chains Directional Gain (dBi)
2.4	4.40	3.40	3.93	6.92

Antenna 1 and Antenna 4:

Band (GHz)	Chain 0 Antenna 1 Gain (dBi)	Chain 1 Antenna 4 Gain (dBi)	Uncorrelated Chains Directional Gain (dBi)	Correlated Chains Directional Gain (dBi)
2.4	4.40	3.10	3.80	6.78

Antenna 2 and Antenna 3:

Band (GHz)	Chain 0 Antenna 2 Gain (dBi)	Chain 1 Antenna 3 Gain (dBi)	Uncorrelated Chains Directional Gain (dBi)	Correlated Chains Directional Gain (dBi)
2.4	2.10	3.40	2.80	5.78

Antenna 2 and Antenna 4:

Band (GHz)	Chain 0 Antenna 2 Gain (dBi)	Chain 1 Antenna 4 Gain (dBi)	Uncorrelated Chains Directional Gain (dBi)	Correlated Chains Directional Gain (dBi)
2.4	2.10	3.10	2.63	5.62

Directional Gain value was determined using the following formula:

$$\text{Uncorrelated Directional Gain dBi} = 10 \log [(10^{\text{Ant 1/10}} + 10^{\text{Ant 2/10}})/2]$$

$$\text{Correlated Directional Gain dBi} = 10 \log [(10^{\text{Ant 1/20}} + 10^{\text{Ant 2/20}^2})/2]$$

Uncorrelated Directional Gain sample calculation:

$$2.63 \text{ dBi} = 10 \log [(10^{2.1/10} + 10^{3.1/10})/2]$$

Correlated Directional Gain sample calculation:

$$5.62 \text{ dBi} = 10 \log [(10^{2.1/20} + 10^{(3.1/20)^2})/2]$$

RESULT

9.4.1. 802.11ax HE20 MODE 2TX

2TX Antenna 1 + Antenna 3 CDD OFDMA MODE: 26-Tones, RU Index 0

Test Engineer:	ZS16080 and PV27966
Test Date:	2022-09-21 to 2022-09-22

Limits

Channel	Frequency (MHz)	Directional Gain (dBi)	FCC/ISED Power Limit (dBm)	ISED EIRP Limit (dBm)	Max Power (dBm)
Low 1	2412	3.93	30.00	36	30.00

Results

Channel	Frequency (MHz)	Antenna 1 Meas Power (dBm)	Antenna 3 Meas Power (dBm)	Total Corr'd Power (dBm)	Power Limit (dBm)	Margi (dB)
Low 1	2412	18.04	18.33	21.20	30.00	-8.80

2TX Antenna 1 + Antenna 3 CDD OFDMA MODE: 26-Tones, RU Index 4

Test Engineer:	ZS16080 and PV27966
Test Date:	2022-09-21 to 2022-10-06

Limits

Channel	Frequency (MHz)	Directional Gain (dBi)	FCC/ISED Power Limit (dBm)	ISED EIRP Limit (dBm)	Max Power (dBm)
Mid 6	2437	3.93	30.00	36	30.00

Results

Channel	Frequency (MHz)	Antenna 1 Meas Power (dBm)	Antenna 3 Meas Power (dBm)	Total Corr'd Power (dBm)	Power Limit (dBm)	Margi (dB)
Mid 6	2437	18.24	18.10	21.18	30.00	-8.82

2TX Antenna 1 + Antenna 3 CDD OFDMA MODE: 26-Tones, RU Index 8

Test Engineer:	ZS16080 and PV27966
Test Date:	2022-09-21 to 2022-09-22

Limits

Channel	Frequency (MHz)	Directional Gain (dBi)	FCC/ISED Power Limit (dBm)	ISED EIRP Limit (dBm)	Max Power (dBm)
High 11	2462	3.93	30.00	36	30.00

Results

Channel	Frequency (MHz)	Antenna 1 Meas Power (dBm)	Antenna 3 Meas Power (dBm)	Total Corr'd Power (dBm)	Power Limit (dBm)	Margi (dB)
High 11	2462	18.16	18.23	21.21	30.00	-8.79

2TX Antenna 1 + Antenna 3 CDD OFDMA MODE: 242-Tones, RU Index 61

Test Engineer:	ZS16080 and PV27966
Test Date:	2022-09-21 to 2022-10-06

Limits

Channel	Frequency (MHz)	Directional Gain (dBi)	FCC/ISED Power Limit (dBm)	ISED EIRP Limit (dBm)	Max Power (dBm)
Low 1	2412	3.93	30.00	36	30.00
Mid 6	2437	3.93	30.00	36	30.00
High 11	2462	3.93	30.00	36	30.00

Results

Channel	Frequency (MHz)	Antenna 1 Meas Power (dBm)	Antenna 3 Meas Power (dBm)	Total Corr'd Power (dBm)	Power Limit (dBm)	Margi (dB)
Low 1	2412	17.13	17.37	20.26	30.00	-9.74
Mid 6	2437	18.13	17.36	20.77	30.00	-9.23
High 11	2462	17.21	17.46	20.35	30.00	-9.65

2TX Antenna 1 + Antenna 3 CDD OFDMA MODE: SU, Single User

Test Engineer:	ZS16080 and PV27966
Test Date:	2022-09-21 to 2022-10-06

Limits

Channel	Frequency (MHz)	Directional Gain (dBi)	FCC/ISED Power Limit (dBm)	ISED EIRP Limit (dBm)	Max Power (dBm)
Low 1	2412	3.93	30.00	36	30.00
Mid 6	2437	3.93	30.00	36	30.00
High 11	2462	3.93	30.00	36	30.00

Results

Channel	Frequency (MHz)	Antenna 1 Meas Power (dBm)	Antenna 3 Meas Power (dBm)	Total Corr'd Power (dBm)	Power Limit (dBm)	Margi (dB)
Low 1	2412	17.02	17.34	20.19	30.00	-9.81
Mid 6	2437	16.98	17.29	20.15	30.00	-9.85
High 11	2462	17.13	17.27	20.21	30.00	-9.79

9.4.2. 802.11ax HE40 MODE 2TX

2TX Antenna 1 + Antenna 3 CDD OFDMA MODE: 26-Tones, RU Index 0

Test Engineer:	ZS16080 and PV27966
Test Date:	2022-09-21 to 2022-09-22

Limits

Channel	Frequency (MHz)	Directional Gain (dBi)	FCC/ISED Power Limit (dBm)	ISED EIRP Limit (dBm)	Max Power (dBm)
Low 3	2422	3.93	30.00	36	30.00

Results

Channel	Frequency (MHz)	Antenna 1 Meas Power (dBm)	Antenna 3 Meas Power (dBm)	Total Corr'd Power (dBm)	Power Limit (dBm)	Margi (dB)
Low 3	2422	17.40	17.69	20.56	30.00	-9.44

2TX Antenna 1 + Antenna 3 CDD OFDMA MODE: 26-Tones, RU Index 8

Test Engineer:	ZS16080 and PV27966
Test Date:	2022-09-21 to 2022-10-06

Channel	Frequency (MHz)	Directional Gain (dBi)	FCC/ISED Power Limit (dBm)	ISED EIRP Limit (dBm)	Max Power (dBm)
Mid 6	2437	3.93	30.00	36	30.00

Results

Channel	Frequency (MHz)	Antenna 1 Meas Power (dBm)	Antenna 3 Meas Power (dBm)	Total Corr'd Power (dBm)	Power Limit (dBm)	Margi (dB)
Mid 6	2437	17.57	17.61	20.60	30.00	-9.40

2TX Antenna 1 + Antenna 3 CDD OFDMA MODE: 26-Tones, RU Index 17

Test Engineer:	ZS16080 and PV27966
Test Date:	2022-09-21 to 2022-09-22

Limits

Channel	Frequency (MHz)	Directional Gain (dBi)	FCC/ISED Power Limit (dBm)	ISED EIRP Limit (dBm)	Max Power (dBm)
High 9	2452	3.93	30.00	36	30.00

Results

Channel	Frequency (MHz)	Antenna 1 Meas Power (dBm)	Antenna 3 Meas Power (dBm)	Total Corr'd Power (dBm)	Power Limit (dBm)	Margi (dB)
High 9	2452	17.45	17.66	20.57	30.00	-9.43

2TX Antenna 1 + Antenna 3 CDD OFDMA MODE: 484-Tones, RU Index 65

Test Engineer:	ZS16080 and PV27966
Test Date:	2022-09-21 to 2022-10-06

Limits

Channel	Frequency (MHz)	Directional Gain (dBi)	FCC/ISED Power Limit (dBm)	ISED EIRP Limit (dBm)	Max Power (dBm)
Low 3	2422	3.93	30.00	36	30.00
Mid 6	2437	3.93	30.00	36	30.00
High 9	2452	3.93	30.00	36	30.00

Results

Channel	Frequency (MHz)	Antenna 1 Meas Power (dBm)	Antenna 3 Meas Power (dBm)	Total Corr'd Power (dBm)	Power Limit (dBm)	Margi (dB)
Low 3	2422	19.85	19.74	22.81	30.00	-7.19
Mid 6	2437	19.94	19.79	22.88	30.00	-7.12
High 9	2452	17.86	17.48	20.68	30.00	-9.32

2TX Antenna 1 + Antenna 3 CDD OFDMA MODE: SU, Single User

Test Engineer:	ZS16080 and PV27966
Test Date:	2022-09-21 to 2022-10-06

Limits

Channel	Frequency (MHz)	Directional Gain (dBi)	FCC/ISED Power Limit (dBm)	ISED EIRP Limit (dBm)	Max Power (dBm)
Low 3	2422	3.93	30.00	36	30.00
Mid 6	2437	3.93	30.00	36	30.00
High 9	2452	3.93	30.00	36	30.00

Results

Channel	Frequency (MHz)	Antenna 1 Meas Power (dBm)	Antenna 3 Meas Power (dBm)	Total Corr'd Power (dBm)	Power Limit (dBm)	Margi (dB)
Low 3	2422	19.65	19.67	22.67	30.00	-7.33
Mid 6	2437	19.70	19.50	22.61	30.00	-7.39
High 9	2452	17.82	17.40	20.63	30.00	-9.37

9.5. AVERAGE POWER

LIMITS

None; for reporting purposes only

TEST PROCEDURE

The transmitter output is connected to a power meter.

The power output was measured on the EUT antenna port using SMA cable with 10dB attenuator connected to a power meter via power sensor. Gated average output power was read directly from power meter.

RESULTS

9.5.1. 802.11ax HE20 MODE 2TX

2TX Antenna 1 + Antenna 3 CDD OFDMA MODE: 26-Tones, RU Index 0

Test Engineer:	ZS16080 and PV27966
Test Date:	2022-09-21 to 2022-09-22

Channel	Frequency (MHz)	Antenna 1 Power (dBm)	Antenna 3 Power (dBm)	Total Power (dBm)
Low 1	2412	14.77	14.91	17.85

2TX Antenna 1 + Antenna 3 CDD OFDMA MODE: 26-Tones, RU Index 4

Test Engineer:	ZS16080 and PV27966
Test Date:	2022-09-21 to 2022-10-06

Channel	Frequency (MHz)	Antenna 1 Power (dBm)	Antenna 3 Power (dBm)	Total Power (dBm)
Mid 6	2437	14.82	14.96	17.90

2TX Antenna 1 + Antenna 3 CDD OFDMA MODE: 26-Tones, RU Index 8

Test Engineer:	ZS16080 and PV27966
Test Date:	2022-09-21 to 2022-09-22

Channel	Frequency (MHz)	Antenna 1 Power (dBm)	Antenna 3 Power (dBm)	Total Power (dBm)
High 11	2462	14.79	15.23	18.03

2TX Antenna 1 + Antenna 3 CDD OFDMA MODE: 242-Tones, RU Index 61

Test Engineer:	ZS16080 and PV27966
Test Date:	2022-09-21 to 2022-10-06

Channel	Frequency (MHz)	Antenna 1 Power (dBm)	Antenna 3 Power (dBm)	Total Power (dBm)
Low 1	2412	13.71	13.99	16.86
Mid 6	2437	13.97	14.04	17.02
High 11	2462	13.94	13.90	16.93

2TX Antenna 1 + Antenna 3 CDD OFDMA MODE: SU, Single User

Test Engineer:	ZS16080 and PV27966
Test Date:	2022-09-21 to 2022-10-06

Channel	Frequency (MHz)	Antenna 1 Power (dBm)	Antenna 3 Power (dBm)	Total Power (dBm)
Low 1	2412	13.67	13.90	16.80
Mid 6	2437	13.60	14.01	16.82
High 11	2462	13.85	13.81	16.84

9.5.2. 802.11ax HE40 MODE 2TX

2TX Antenna 1 + Antenna 3 CDD OFDMA MODE: 26-Tones, RU Index 0

Test Engineer:	ZS16080 and PV27966
Test Date:	2022-09-21 to 2022-09-22

Channel	Frequency (MHz)	Antenna 1 Power (dBm)	Antenna 3 Power (dBm)	Total Power (dBm)
Low 3	2422	13.60	14.00	16.81

2TX Antenna 1 + Antenna 3 CDD OFDMA MODE: 26-Tones, RU Index 8

Test Engineer:	ZS16080 and PV27966
Test Date:	2022-09-21 to 2022-10-06

Channel	Frequency (MHz)	Antenna 1 Power (dBm)	Antenna 3 Power (dBm)	Total Power (dBm)
Mid 6	2437	13.85	13.92	16.90

2TX Antenna 1 + Antenna 3 CDD OFDMA MODE: 26-Tones, RU Index 17

Test Engineer:	ZS16080 and PV27966
Test Date:	2022-09-21 to 2022-09-22

Channel	Frequency (MHz)	Antenna 1 Power (dBm)	Antenna 3 Power (dBm)	Total Power (dBm)
High 9	2452	13.84	13.88	16.87

2TX Antenna 1 + Antenna 3 CDD OFDMA MODE: 484-Tones, RU Index 65

Test Engineer:	ZS16080 and PV27966
Test Date:	2022-09-21 to 2022-10-06

Channel	Frequency (MHz)	Antenna 1 Power (dBm)	Antenna 3 Power (dBm)	Total Power (dBm)
Low 3	2422	13.75	13.87	16.82
Mid 6	2437	13.80	13.93	16.88
High 9	2452	11.93	12.04	15.00

2TX Antenna 1 + Antenna 3 CDD OFDMA MODE: SU, Single User

Test Engineer:	ZS16080 and PV27966
Test Date:	2022-09-21 to 2022-10-06

Channel	Frequency (MHz)	Antenna 1 Power (dBm)	Antenna 3 Power (dBm)	Total Power (dBm)
Low 3	2422	13.70	13.86	16.79
Mid 6	2437	13.69	13.84	16.78
High 9	2452	11.86	11.79	14.84

9.6. POWER SPECTRAL DENSITY

LIMITS

FCC §15.407 (e)

RSS-247(5.2) (b)

The power spectral density conducted from the transmitter to the antenna shall not be greater than 8 dBm in any 3 kHz band during any time interval of continuous transmission.

RESULTS

9.6.1. 802.11ax HE20 MODE 2TX

2TX Antenna 1 + Antenna 3 CDD OFDMA MODE: 26-Tones, RU Index 0

Duty Cycle CF (dB)	3.04	Included in Calculations of Corr'd PSD
--------------------	------	--

PSD Results

Channel	Frequency (MHz)	Antenna 1 Meas (dBm/3kHz)	Antenna 3 Meas (dBm/3kHz)	Total Corr'd PSD (dBm/3kHz)	Limit (dBm/3kHz)	Margin (dB)
Low 1	2412	-1.335	-1.261	4.75	8.0	-3.2

LOW CHANNEL 1

