

empowered by
smartz

USER MANUAL



COPYRIGHT INFORMATION

Copyright 2010-2019 Simavita Ltd. All rights reserved.

The information contained in this User Manual is the sole property of Simavita and may not be duplicated without permission. This User Manual may be revised or replaced by Simavita Ltd at any time and without notice.

Please ensure that you have the latest version of this manual; in case you need help contact Simavita Technical Support Department.

Table of Contents

Copyright Information	2
Table of Contents	3
Preface	4
Purpose of this manual.....	4
Qualification of Personnel	4
Warranty.....	4
Document Conventions	4
1.0 Safety Information	6
1.1 Definitions.....	6
1.2 Warnings.....	7
1.3 Cautions	10
1.4 Symbols and markings	11
1.5 Labels	133
1.6 Disposal.....	14
2.0 Overview	166
2.1 What is the SMARTZ system	166
2.4 The SMARTZ technology components.....	19
3.0 USER INSTRUCTIONS	222
3.1 BATTERY INSTALLATION / REPLACEMENT	222
3.2 SMARTZ app INSTALLATION	233
3.3 CLIPPING SMARTZ POD ONTO PAD	233
3.3 USING THE SMARTZ APP.....	255
4.0 SMARTZ Components Cleaning Instructions.....	277
4.1 SMARTZ pod cleaning Guide.....	277
4.2 Recommended Cleaning Solution and Precautions.....	277
4.3 SMARTZ pod Cleaning and Inspection	27
5.0 Contact and Support	29
5.1 SMARTZ™ pod Indicator Light Colors	29
5.2 Troubleshooting Guide	29
5.4 Contact and support	30
APPENDIX A SMARTZ™ system Specifications	32
SMARTZ physical Specifications.....	32
SMARTZ electrical Specifications	32
SMARTZ pod BLUETOOTH Specifications.....	32
SMARTZ devices Environmental Conditions	Error! Bookmark not defined.
SMARTZ system Patient Environment	33
SMARTZ system Manufacturers Declaration	34
GLOSSARY.....	37
List of Figures	37

Preface

PURPOSE OF THIS MANUAL

This manual contains important information regarding the safe operation of your SMARTZ system.

Ensure that you read and understand the information contained in this manual before operating any component of SMARTZ system.

Further help on SMARTZ system is available in the SMARTZ APP.

The word **Patient** is defined as the person being cared for.

WARNING

Before operating the SMARTZ system read, understand and strictly follow the information contained in Section [1.0 Safety Information](#).

QUALIFICATION OF PERSONNEL

Read the SMARTZ system warnings and cautions prior to usage. Simavita recommends that the registration and maintenance of the SMARTZ system be performed by personnel with authority to make decisions on behalf of the organization. Only use original parts and equipment approved by Simavita.

WARRANTY

Information regarding your product warranty will be available from your sales representative or Simavita.

DOCUMENT CONVENTIONS

This document uses the following typographic conventions:

Screen names and screen displays: **BOLD+Calibri**

SECTION 1

**SAFETY
INFORMATION**

1.0 Safety Information

1.1 DEFINITIONS

This manual uses three indicators to highlight critical information: **WARNING**, **CAUTION** and **Note**. These are defined as follows:

WARNING

A **WARNING** indicates a condition that can endanger the Patient or the SMARTZ system operator.

CAUTION

A **CAUTION** indicates a condition that can damage the equipment.

Note:

A Note indicates points of particular emphasis that make the operation of the SMARTZ system more efficient or convenient.

In order to use the system correctly and efficiently, and to help prevent incidents, please pay attention to [Section 1.2 Warnings](#), [Section 1.3 Cautions](#), as well as all warnings and cautions contained throughout this manual.

1.2 WARNINGS

General Warnings Related to the Use of SMARTZ

WARNING

The SMARTZ system must be used according to the instructions provided.

A Patient in a clinical environment is highly vulnerable to the risks of infection. Dirty or contaminated equipment is a potential source of infection. Clean the SMARTZ pod regularly and systematically, before and after each use. Follow all internal procedures within your organization, as well as any maintenance procedures, to reduce the risks of infection.

To reduce the risk of infection, organization's standard operating procedures for cleaning, disinfection and hygiene must be followed at all times. At a minimum you should wash your hands thoroughly before and after handling any part of the SMARTZ system.

SMARTZ is not a substitute for standard care practices. Ensure that the care personnel is able and prepared to take suitable action in the event if any part of the SMARTZ system experiences a problem.

If there is a leakage, as there may be with any continence product, there may be a risk of rash, sores and/or compromise of skin integrity requiring medical intervention during a continence assessment. Care personnel should continually monitor and interact with the Patient.

The SMARTZ sensor pad should not be applied to a Patient who has a known pre-existing skin condition, such as a rash, sores and/or a compromise of skin integrity in accordance to organization clinical practices.

Some Patients may be sensitive to materials used in the SMARTZ components. It is important that the Patient's care provider continually monitors and interacts with the Patient. If the Patient is sensitive to the materials used in the SMARTZ™ components, discontinue use and contact Simavita.

If a Patient develops a skin irritation as a result of wearing the SMARTZ sensor pad or pod, discontinue use and care personnel should continually monitor and interact with the Patient.

SMARTZ sensor pads could potentially pose a biohazard risk. The SMARTZ sensor pads should be disposed of, as per the standard operating procedures of your organization.

The LED Indicator lights on the SMARTZ pod indicate different events and functions. Refer to the Section [SMARTZ pod Indicator Light Colors](#) for information on the LED Indicator light definition before determining the relevant user action.

Ensure SMARTZ system components are stored and transported according to SMARTZ devices Environmental Conditions as defined in APPENDIX A SMARTZ system Specifications.

General Warnings Related to System Installation

WARNING

The SMARTZ system must not be installed in an environment that limits or prohibits RF transmitting devices.

The SMARTZ pod, sensor pad and app must not be used in the presence of medical imaging equipment such as MRI machines, ECG machines, Defibrillators, etc.

Do not connect items which are not specified as part of the SMARTZ system.

The SMARTZ pod and SMARTZ sensor pad must not be stored or placed close to radiant heat sources, such as a lit fireplace.

The SMARTZ pod and sensor pad must not be stored or placed close to the sources of steam, such as steam kettles.

The SMARTZ pod and sensor pad must not be stored or placed close to microwave ovens.

Do not make changes to the App settings as this may render the system inoperable.

Warnings Regarding Maintenance

WARNING

- The SMARTZ pod should be inspected for any visible damage after every use and not less frequently than every 12 weeks.
- Never use any component or accessory of the SMARTZ system that appears to be damaged or not functioning correctly. If any signs of damage or malfunction are evident, discontinue use and contact your supplier of the SMARTZ system.
- If you cannot determine the cause of the problem with any component or accessory of the SMARTZ system, contact supplier. Do not use the SMARTZ system until the problem has been corrected.
- Do not attempt to repair, modify or service any component or accessory of the SMARTZ system. The system does not contain any user serviceable parts. Doing so might cause damage and/or void your warranty.
- Only clean SMARTZ components with cleaning agents specified in cleaning instructions. Read and follow the cleaning and additional instructions on the cleaning agents to clean the SMARTZ components.
- The SMARTZ sensor pad is intended for single use only. Use as per manufacturer instruction and do not attempt to wash or reuse these components.
- Only perform upgrades to any software components of the SMARTZ system by following instructions provided by Simavita.
- Never use accessories, detachable parts or materials that are not described in this User Manual. To order new accessories, please contact supplier.
- The SMARTZ pod must not be serviced or maintained when in use on a Patient.

Warnings Regarding Oxygen

WARNING

- The SMARTZ system is NOT suitable for use in the presence of a FLAMMABLE ANAESTHETIC MIXTURE WITH AIR or with OXYGEN or NITROUS OXIDE.

Warnings Regarding Instructional Safeguards for batteries

WARNING

- The SMARTZ pod contains a user replaceable coin cell battery, type CR2016, contained behind a snap-fit battery compartment lid that requires a small flat head screwdriver to open.
 - Do not ingest battery, Chemical Burn Hazard.
 - If the coin / button cell battery is swallowed it can cause severe internal burns in just 2 hours and lead to death.
 - Keep new and used batteries away from children
 - If the battery compartment does not close securely, stop using the product and keep it away from children
 - If you think batteries might have been swallowed or placed inside any part of the body, seek immediate medical attention

1.3 CAUTIONS

General Precautions for Use

CAUTION

- The SMARTZ pod may be damaged by excessive force being applied during cleaning. The cleaning procedures specified in [3.0 SMARTZ components Cleaning Instructions](#) must be followed to prevent damage.
- The components of the SMARTZ system may be damaged through the use of harsh cleaning products. The cleaning procedures specified in [3.0 SMARTZ components Cleaning Instructions](#) must be followed to prevent damage.

Precautions should be taken when handling the SMARTZ pod. Avoid touching the pins as this may trigger a SMARTZ sensor pad connection event.

Precautions regarding Electromagnetic Interference

CAUTION

- The SMARTZ system requires special precautions for electromagnetic compatibility and should be operated in accordance with the recommendations in this manual.
Note: The use of nearby mobile and portable communications equipment using radio frequencies exceeding the levels set in the IEC 60601-1-2 standard may affect its operation.







The use of any accessory other than those specified may lead to an increase in electromagnetic emissions or a decrease in the equipment protection against electromagnetic emissions.



General Precautions Related to the incorporation into the IT-network

CAUTION

- The connection of SMARTZ™ system to an IT network that includes other equipment could result in previously unidentified risks to Patient, operators or third parties. The IT administrator should identify, analyze, evaluate and control these risks before connecting the SMARTZ system to the network.
- Changes to the IT network including but not limited to changes in the IT network configuration, connection of additional items to the IT network, disconnection of items from the IT network, the update of equipment connected to the IT network and upgrade of equipment connected to the IT network, could affect the operation of SMARTZ . The IT administrator should assess the risks to the SMARTZ system before implementing any of these changes.



1.4 SYMBOLS AND MARKINGS

Symbol	Description
	<p>ISO 7010-W001 General Warning sign.</p> <p>This symbol accompanies WARNING in Simavita product literature.</p>
	<p>IEC 60417-5140 (2003-04) Equipment includes an RF transmitter.</p> <p>This symbol appears on the SMARTZ™ pod.</p>
	<p>ISO 7000-2498 Serial Number</p> <p>This symbol appears on all SMARTZ components.</p>
	<p>WEEE (Waste Electrical and Electronic Equipment)</p> <p>This means the product must not be disposed of as household waste. Observe local ordinances for proper disposal. This symbol appears on all SMARTZ™ components. Refer to section 1.6 Disposal for information and instructions for disposal.</p>
	<p>RCM</p> <p>Compliance with Electrical Equipment Safety System (EESS) of Australian Communications and Media Authority (ACMA) Regulation.</p> <p>This symbol appears on the SMARTZ pod.</p>
	<p>CE Marking. Declares that the product conforms to the essential requirements of the applicable EC directives.</p> <p>This symbol appears on the SMARTZ components and all accompanying documentation and packaging.</p>
	<p>United States FCC</p> <p>This SMARTZ™ pod complies with Part 15 of the Federal Communications Commission (FCC) Rules.</p> <p>The FCC ID for SMARTZ™ pod is: SBG-8000-POD</p> <p>Operation is subject to the following two conditions: (1) this device may not cause harmful interference, and (2) this device must accept any interference received, including interference that may cause undesired operation.</p> <p>This symbol appears in the package insert for SMARTZ pod.</p>

<h1>IP54</h1>	<p>IP rating code of Smartz pod, which classifies the protection against intrusion from dust and water.</p> <p>This symbol appears on the SMARTZ pod.</p> <p>The first digit indicates the level of protection that the enclosure provides against access to hazardous parts The number 5 indicates that the enclosure is protected from limited dust ingress.</p> <p>The second digit indicates the level of protection that the enclosure provides against harmful ingress of water. The Number 4 on SMARTZ pod indicates that pod is protected against water splashed from all directions.</p>
	<p>Keep Dry.</p> <p>This symbol appears on the SMARTZ pod packaging.</p>
	<p>Indicates that the packaging should be recycled.</p> <p>This symbol appears on the SMARTZ pod packaging.</p>
	<p>Device includes static sensitive components: take appropriate precautions</p>

1.5 LABELS

Various labels and specific markings are affixed to the SMARTZ system components that describe precautions and contribute to traceability of the product. The labels are identified in the table below with illustrations of their location.

Label	Description	Location
 <p>smartz pod Model: 8000</p> <p>SN S-0A2-L1W IP54 CE</p> <p>www.simavita.com Simavita (Aust) Pty. Ltd. Made in Australia</p> <p>FCC ID: SBG-8000-POD 02863_04</p>	<p>SMARTZ pod label</p>	

1.6 DISPOSAL

This section describes the steps to safely dispose the SMARTZ components and accessories.

SMARTZ SENSOR PAD

The SMARTZ sensor pad may pose a biohazard risk after usage. The SMARTZ sensor pad should be disposed of in accordance with the standard operating procedures at your facility for bio hazardous waste.

SMARTZ POD

The SMARTZ pod contain electronic parts and CR2016 Lithium batteries. These should not be disposed of in standard waste.

The SMARTZ pod has a useful operating life of three (3) years.

WEEE 2002/96/EC is a European Directive that requires the proper disposal of electrical and electronic equipment. These devices should be disposed of separately, not as unsorted municipal waste. To dispose of your device, you should use appropriate collection, reuse and recycling systems available in your region. The use of these collection, reuse and recycling systems is designed to reduce pressure on natural resources and prevent hazardous substances from damaging the environment. If you need information on these disposal systems, please contact your local waste administration. The crossed-bin symbol invites you to use these disposal systems. If you require further information on collection and disposal of your Simavita device please contact Simavita.

SECTION 2
OVERVIEW

2.0 Overview

2.1 WHAT IS THE SMARTZ SYSTEM

SMARTZ is a smart diaper solution for adults and infants. A SMARTZ pod is attached to sensor pad, the pad contain printed sensors providing real-time alerts to caregivers that “it’s time to change” (Figure 1). It is simple to use, intelligent and affordable, providing peace of mind to caregivers and parents.



Figure 1 SMARTZ sensor pad and pod

The SMARTZ is a lightweight, slim, wearable technology that clips onto diapers that is sufficiently economical for everyday use. The simple form is easy to use and comfortable for the wearer to attach and detach from a diaper. The SMARTZ pod (see Figure 2) has been designed to operate continuously and monitor the wetness of diaper 24/7. It uses Bluetooth to transmit data to the SMARTZ APP running on a smart device for processing and display.



Figure 2 SMARTZ pod

The SMARTZ app (Figure 3) provides single and multi-user monitoring capabilities allowing it to be used at home or in care organizations. Data from multiple sensor readings are analyzed to filter out noise, reducing false positive alerts. The app employs patented data analytic techniques to generate trends and present patterns so users can make quick and informed decision on care provision.

To assist in managing many users, a triaging and traffic light system can prioritize care based on location and context. In single user mode, and in the case of the smart watch, it can report sensor readings of the closest Pod in the vicinity.



Figure 3 SMARTZ™ app

When a SMARTZ app uses a traffic light system to inform the user of the optimum time to change product and reduce risk of urine leakage. A Green status is shown when the SMARTZ pad is dry, when it is wet but still within safe pad capacity it turns Yellow. When safe pad capacity has been reached or exceeded the status turns Red to inform the user to change the product.

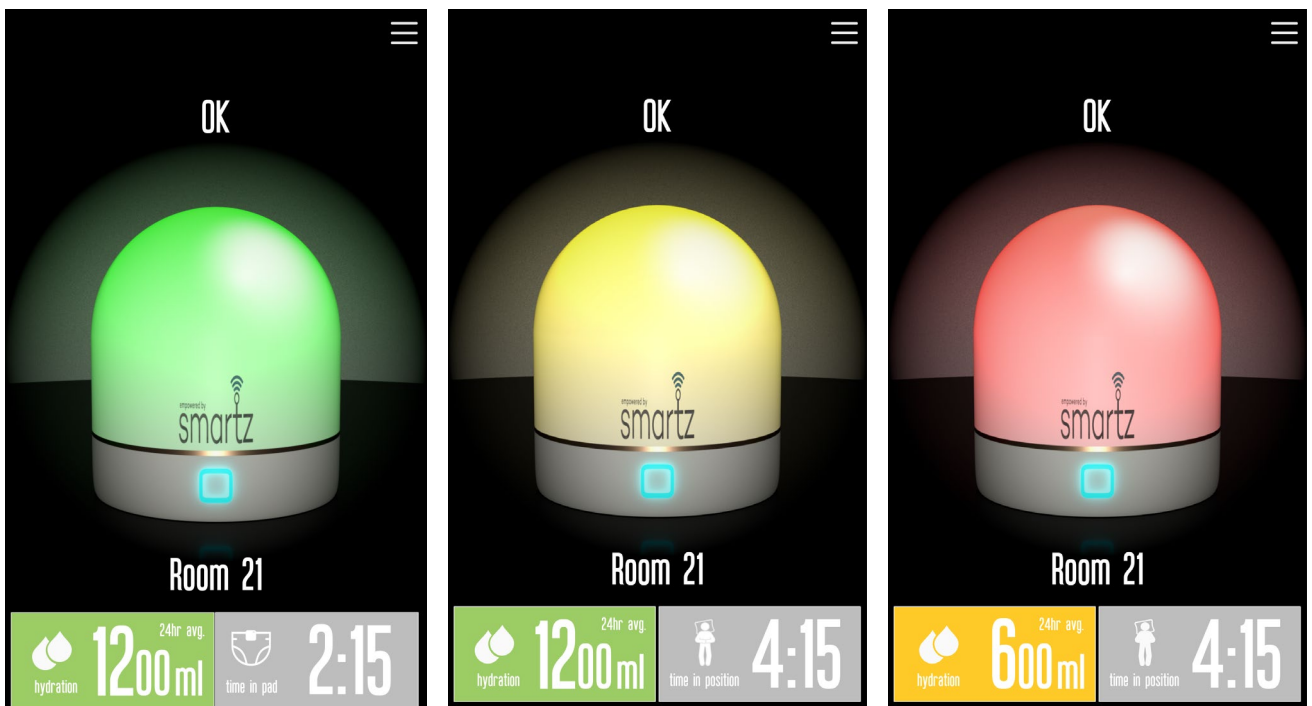

Figure 4 Overview of the SMARTZ app Time-To-Change status

2.4 THE SMARTZ TECHNOLOGY COMPONENTS

SMARTZ uses industry standard Bluetooth technology to connect to virtually all smart devices available on the market. Sensor data and knowledge can be shared to distribute workload and improve continuity of care.



Figure 5 SMARTZ™ network

SMARTZ consists of a number of components to enable the system to function. These components are stated and described in the following table:

SMARTZ™ components		
Component	Description	User interaction
SMARTZ™ sensor pad	<p>Disposable single-patient-use incontinence pad (diaper), with integrated wetness sensor for daily use.</p> <p>The SMARTZ sensor pad consists of a standard continence pad (diaper) with printed capacitive sensors. The sensor has 2 sets capacitive electrodes for improved reliability and coverage. Sensors work on the principle of capacitance similar to touch screens on mobile phones. The sensors detect the accumulation of liquid in the diaper over time.</p>	Care staff, Patient
SMARTZ™ pod	<p>A portable, reusable data transceiver that is connected to the SMARTZ sensor pad and worn daily or as needed by the Patient.</p> <p>The SMARTZ pod is a small and lightweight data logging device. The pod has been designed to an IP54 rating, allowing it to be cleaned by wiping with cleaning solutions. The SMARTZ pod contains a CR2016 Lithium battery and an electronic circuit board containing Bluetooth radio module, micro-controller, memory, and charging circuitry. SMARTZ</p>	Care staff, organization IT staff (during setup)

	<p>pod is equipped with a safety circuit that limits the electrical energy available when a SMARTZ™ sensor pad is connected.</p> <p>SMARTZ pods should be associated to a patient prior to use via the SMARTZ app. The SMARTZ pod requires connection to SMARTZ pad and SMARTZ APP to perform its monitoring and notification function.</p> <div data-bbox="472 443 1206 954" data-label="Image"> </div> <p data-bbox="719 958 951 987" style="text-align: center;">Figure 6 SMARTZ™ pod</p>	
--	--	--

<p>SMARTZ™ app</p>	<p>A software application operating on a smart device performing data collation, storage, processing and display function. Analyses data transmitted from the Pod and informs the user of diaper status and best time to change product. Monitors come in two variants, dedicated and smart device. The dedicated monitor is a completely plug and play bedside unit that changes color depending on diaper wetness. A smart device can function as a monitor when the SMARTZ™ app is installed. The app extends the monitoring capability by analyzing and presenting health status information thru the touch screen interface.</p>	<p>Care staff</p>
--------------------	---	-------------------

SECTION 3

SMARTZ™ USER INSTRUCTIONS

3.0 USER INSTRUCTIONS

3.1 BATTERY INSTALLATION / REPLACEMENT

The SMARTZ pod uses a replaceable CR2016 battery, follow instructions below to install the battery for first time use or to replace the battery:

1. Place the SMARTZ pod face up on a flat surface
2. Insert a flat tool into battery compartment and carefully pry the battery compartment open



3. Remove the old battery and install the new one (CR2016) with the plus (+) symbol facing up



4. The light on the SMARTZ™ pod will turn green for a moment to indicate that battery has been installed correctly



5. Gently slide the battery compartment closed. It locks automatically.

3.2 SMARTZ APP INSTALLATION

The SMARTZ app is required for communicating with the SMARTZ pod and display of pad wetness and Time-to-Change status. The SMARTZ app is compatible with Apple and Android phones, follow the instructions below to install the SMARTZ app:

1. Depending on your smart device:
 - a. Apple phones, go to the App Store/iTunes
 - b. Android phones, go to Play Store
2. Search for “smartz”, tap on “SMARTZ”
3. Download and Install SMARTZ app
4. Launch the SMARTZ app after download and installation has completed
5. Follow and complete setup instructions in the SMARTZ app

3.3 CLIPPING SMARTZ POD ONTO PAD

To enable monitoring function the SMARTZ pod need to be clipped onto the pad as follows:

1. Open the clip off SMARTZ pod clip



2. Unfold the SMARTZ pad

- Line up the three (3) stripes of the SMARTZ pad with the three (3) dots on the SMARTZ pod



- Change SMARTZ pad as required and re-clip SMARTZ pod onto new pad
- Clip the SMARTZ pod onto the front of the SMARTZ pad



- The light on the SMARTZ pod will turn green for a moment to indicate that it has been clipped onto the SMARTZ pad correctly
- For correct operation, the SMARTZ pod needs to be attached to the SMARTZ sensor and worn around the waist region. The SMARTZ pod needs to be flipped inwards towards the body and tucked in securely when worn.

3.3 USING THE SMARTZ APP

Use the SMARTZ app to view the wetness status of the pad and get notifications on Time-to-Change.

Follow instructions in 3.2 to install and setup the SMARTZ app

Launch the SMARTZ app

Clip SMARTZ pod onto the pad as per instructions in 3.3

The SMARTZ app will show the following status based on wetness detected:

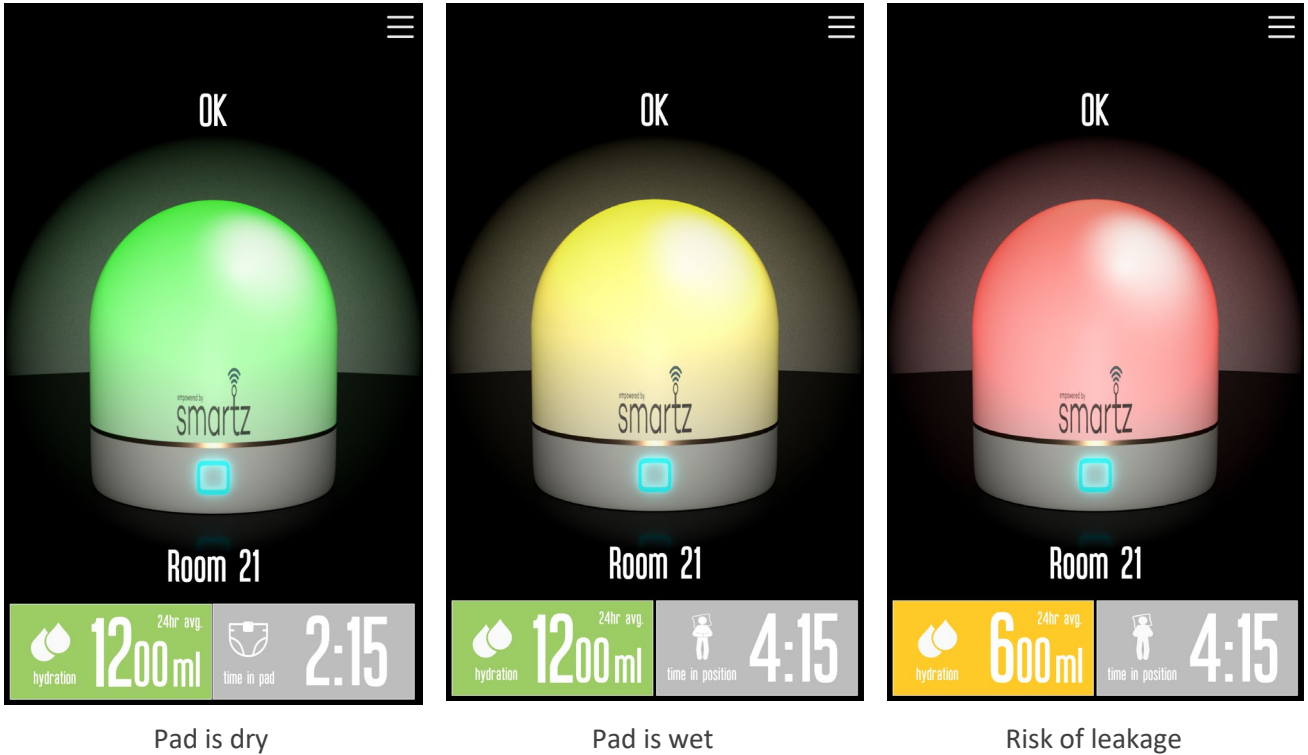

The following are recommended actions based on the status shown

Status Color	Action	Description
	No action	Pad is new or not wet
	Change if necessary	Pad is wet
	Change immediately	Pad capacity has reached and is at risk of leaking

On rare occasions warnings are shown on screen, follow the instructions to resolve them

SECTION 4

SMARTZ CLEANING INSTRUCTIONS

4.0 SMARTZ Components Cleaning Instructions

4.1 SMARTZ POD CLEANING GUIDE

Simavita recognizes that cleaning and disinfection practices vary amongst Home and Care Facilities. It is not possible for Simavita to be responsible for the effectiveness of cleaning the SMARTZ components.

SMARTZ components that come into contact with patients need to be disinfected after each use. Otherwise transmission of infectious agents to patients may occur through direct contact with contaminated equipment.

The level of cleaning required depends on the objects involved and the risk of contamination e.g. Surfaces that are likely to be contaminated with infectious agents (e.g. shared clinical equipment) require cleaning between each use.

4.2 RECOMMENDED CLEANING SOLUTION AND PRECAUTIONS

Simavita products are classified as non-critical items (NHMRC 2010) and can be cleaned with a pH neutral (mild) detergent solution designed for general purpose cleaning. Detergent impregnated wipes may be used to clean single pieces of equipment such as Simavita products with small surface areas.

CAUTION

- To prevent disease transmission, use disposable water proof surgical gloves when handling contaminated SMARTZ pods.
- Do not leave the SMARTZ pod soaking in water.

4.3 SMARTZ POD CLEANING AND INSPECTION

Clean and inspect the SMARTZ pod as follows:

1. The SMARTZ pod is water proof and safe to get wet.
2. Clean the SMARTZ pod by wiping with cleaning solutions according to your infection control protocol.
3. Dry the SMARTZ pod thoroughly, especially around the gold pins.

SECTION 5

CONTACT AND SUPPORT

5.0 Contact and Support

5.1 SMARTZ™ POD INDICATOR LIGHT COLORS

Pod Condition	Indicator Light	Timing	Instruction for user
Power-on	Green	ON for 1 sec.	Battery OK
Sensor has been correctly clipped on	Green	ON for 1 sec.	Sensor connected
Default state when there are no issues (undocked)	Off	Off	-

5.2 TROUBLESHOOTING GUIDE

Symptom	Corrective Action
1. No Green Light when clipped on to SMARTZ pad	<ul style="list-style-type: none">• Check alignment of the pod on the pad to ensure the three (3) data pins on the pod are lined up with the three (3) sensor stripes on pad and re-clip pod onto pad.• Change battery in pod as required
2. SMARTZ pod not detected by SMARTZ app	<ul style="list-style-type: none">• Ensure SMARTZ pod is within the same room as the smart device running the SMARTZ app Note: Bluetooth has short transmission range and connection is affected by obstacles and other RF interference sources.• Check if Green light appears when clipping the SMARTZ pod onto SMARTZ pad. If there is no green light replace the battery in SMARTZ pod.

5.4 CONTACT AND SUPPORT

Please contact Simavita or your authorized distributor. via the contact information provided for assistance, if needed, in setting up, using or maintaining the SMARTZ system or to report unexpected operation or events.

Customer Service Contact: Australia and New Zealand

Inside Australia Phone: 1300 SIM sensor (1300 746 736)

Outside Australia Phone: +61 (2) 8405 6300

Email: customerservice@simavita.com

NOTE: Authorized distributors can be found at the website below:

Website: www.smartzhealth.com

Appendix A

SMARTZ SPECIFICATIONS

APPENDIX A SMARTZ™ system Specifications

SMARTZ™ PHYSICAL SPECIFICATIONS

Description	Length (mm)	Width (mm)	Height (mm)	Weight (g)
SMARTZ™ pod	40	38	9	16

SMARTZ™ ELECTRICAL SPECIFICATIONS

SMARTZ™ POD REPLACEABLE BATTERY

Description	Specification
Brand	Energizer CR2016
Chemistry	Lithium
Voltage	3.0 Vdc
Ampere Hour Rating	100 mAh

SMARTZ™ POD BLUETOOTH SPECIFICATIONS

The wireless specifications are as follows;

Description	Specification
BLE	Version 4/5
Frequency Band	2.400 – 2.485 GHz

WARNING

The SMARTZ pod may be interfered with by other equipment, even if that other equipment complies with CISPR EMISSION requirements.

SMARTZ SYSTEM PATIENT ENVIRONMENT

The SMARTZ system is Radio Equipment Device certified for use in a medical environment. Simavita has tested, certified and classified the SMARTZ pod as a Radio Equipment Device.

⚠ WARNING

1. In order to ensure that patient safety is maintained at all times, the SMARTZ pod or other electrical equipment must not be placed within the patient environment as defined and illustrated below.
2. In case of emergency, disconnect the equipment from power supply mains.
3. In order to ensure that patient safety is maintained at all times, the operator must not touch the Patient at the same time if the patient is connected to the SMARTZ pod and the sensor pad.

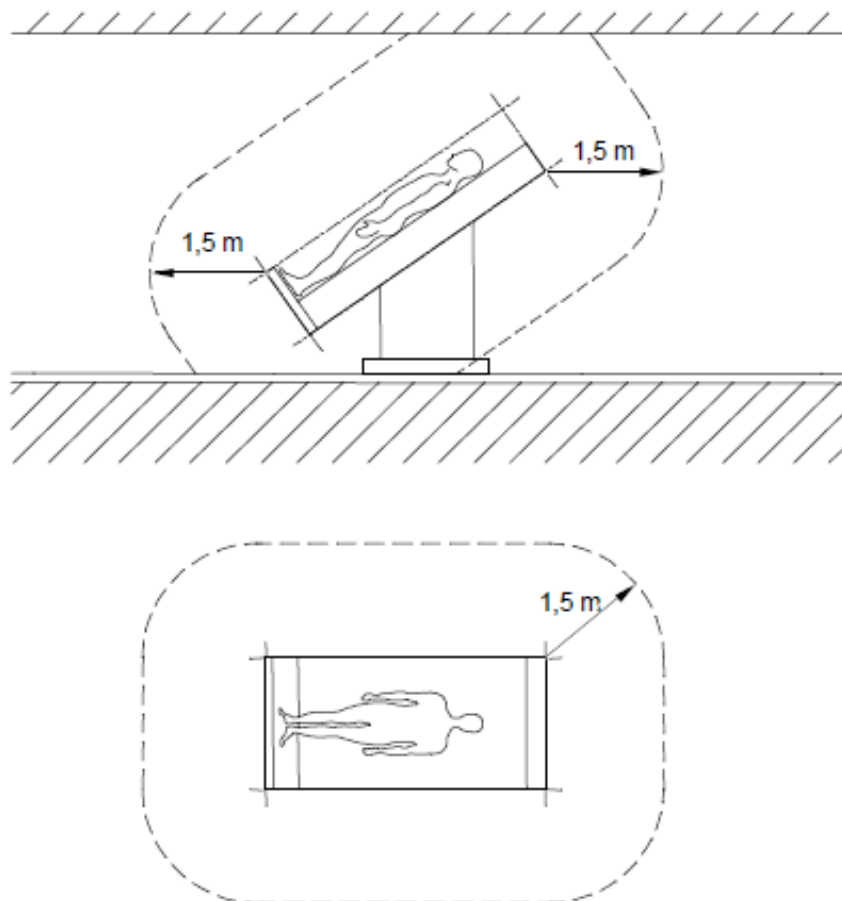

IEC 2431/05

Figure 7 SMARTZ system Usage Warning

SMARTZ SYSTEM MANUFACTURERS DECLARATION

The following tables contain the manufacturer's declarations for the SMARTZ system electromagnetic emissions, electromagnetic immunity, and recommended separation distances between the SMARTZ system and portable and mobile RF communications equipment as well as a list of compliant cables.

FCC COMPLIANCE STATEMENT

This device complies with Part 15 of the Federal Communications Commission (FCC) Rules. The FCC ID for this device is SBG-8000-POD. Operation is subject to the following two conditions: (1) this device may not cause harmful interference, and (2) this device must accept any interference received, including interference that may cause undesired operation.

CAUTION:

Changes or modifications to this unit not expressly approved by the party responsible for compliance could void the user's authority to operate this equipment. This equipment has been tested and found to comply with the limits for a Class B digital device, pursuant to Part 15 of the FCC Rules. These limits are designed to provide reasonable protection against harmful interference in a residential installation. This equipment generates, uses and can radiate radio frequency energy and, if not installed and used in accordance with the manufacturer's instructions, may cause interference harmful to radio communications.

There is no guarantee, however, that interference will not occur in a particular installation. If this equipment does cause harmful interference to radio or television reception, which can be determined by turning the equipment off and on, the user is encouraged to try to correct the interference by one or more of the following measures: (1) reorient or relocate the receiving antenna, (2) increase the separation between the equipment and receiver, (3) connect the equipment to an outlet on a circuit different from that to which the receiver is connected, and (4) consult the dealer or an experienced radio or TV technician for help.

The SMARTZ™ pod with FCC ID **SBG-8000-POD** is subject to Part 15 Subpart C. This transmitter must not be co-located or operated in conjunction with any other antenna or transmitter.

The available scientific evidence does not show that any health problems are associated with using low power wireless devices. There is no proof, however, that these low power wireless devices are absolutely safe. Low power Wireless devices emit low levels of radio frequency energy (RF) in the microwave range while being used. Whereas high levels of RF can produce health effects (by heating tissue), exposure of low-level RF that does not produce heating effects causes no known adverse health effects. Many studies of low-level RF exposures have not found any biological effects. Some studies have suggested that some biological effects might occur, but such findings have not been confirmed by additional research. [SMARTZ™ pod] has been tested and found to comply with FCC radiation exposure limits set forth for an uncontrolled environment and meets the FCC radio frequency (RF) Exposure Guidelines in Supplement C to OET65. Changes or modifications not expressly approved by the party responsible for compliance could void the user's authority to operate the equipment.

RF Exposure Information

The SAS pod is designed to sit directly against the patient's body, with a 3.8mm gap of plastic between the patient and the battery side of the SAS pod PCBA .

According to KDB 447498 D01 General RF Exposure Guidance V06 SAR testing can be exempted if the following exclusion threshold are met

General SAR test exclusion guidance

Standalone SAR test exclusion considerations

For 100 MHz to 6 GHz and test separation distances $\leq 50\text{mm}$, the 1-g and 10-g SAR test exclusion Thresholds are determined by the following:

$[(\text{max. power of channel, including tune-up tolerance, mW})/(\text{min. test separation distance, mm})] [\sqrt{f_{(\text{GHz})}}] \leq 3.0$ for 1-g SAR, and ≤ 7.5 for 10-g extremity SAR,³⁰ where

$f_{(\text{GHz})}$ is the RF channel transmit frequency in GHz

Power and distance are rounded to the nearest mW and mm before calculation

The result is rounded to one decimal place for comparison

The values 3.0 and 7.5 are referred to as numeric thresholds in step b) below

The test exclusions are applicable only when the minimum test separation distance is $\leq 50\text{mm}$ and for transmission frequencies between 100MHz and 6GHz. When the minimum test separation distance is $< 5\text{mm}$, a distance fo 5mm according to 4.1 f) is applied to determine SAR test exclusion.

$P_{\text{threshold}} = \text{Maximum Rated Conducted Output Power (dBm)} + \text{Tune –Up Tolerance} - \text{Maximum Path Loss to Antenna}$

$P_{\text{threshold_DUT}} = 1\text{mW} * 10^{(0 \text{ dBm}/10)} = 1\text{mW}$

FCC General SAR test exclusion acc. KDB 447498 D01 v06					
Frequency (MHz)	Max.Power Incl.Tune – up Tolerance (mW)	Threshold 1-g SAR Limit <3.0	Threshold 10-g SAR Limit < 7.5	1-G SAR Exemption Fulfilled	10-g SAR Exemption Fulfilled
2402.0	1.000	0.3100	0.3100	yes	yes
2426.0	1.000	0.3115	0.3115	yes	yes
2480.0	1.000	0.3150	0.3150	yes	yes

According to EN 62479-2010 SAR testing can be exempted if the low power exclusion level is met as follows:

Table A.1 – Example values of SAR-based P_{max} for some cases described by ICINRP, IEEE Std C95.1-1999 and IEEE Std C95.1-2005

Guideline/Standard	SAR limit, SAR_{max} W/kg	Averaging mass, m	P_{max} mW	Exposure tier	Region of body
ICINRP	2	10	20	General public	Head and Trunk
	4	10	40	General public	Limbs
	10	10	100	Occupational	Head and Trunk
	20	10	200	Occupational	Limbs
IEEE Std. C95.1-1999[2]	1.6	1	1.6	Uncontrolled Environment	Head, trunk Arms, legs
	4	10	40	Uncontrolled Environment	Hands, wrists , feet and ankles
	8	1	8	Controlled Environment	Head, trunk Arms, legs
	20	10	200	Control Environment	Hands, wrists , Feet and ankles
IEEE Std C95.1- 2005 [3]	2	10	20	Action level	Body except extremities and pinnae
	4	10	40	Action level	Extremities and pinnae
	10	10	100	Controlled Environment	Body except extremities and pinnae
	20	10	200	Controlled Environment	Extremities and pinnae

$P_{max} = \text{Maximum Rated Conducted Output Power (dBm)} + \text{Tune -Up Tolerance} - \text{Maximum Path Loss to antenna}$

$$P_{MAX_DUT} = 1\text{mW} * 10^{(0 \text{ dBm}/10)} = 1\text{mW}$$

⚠ WARNING

Portable and mobile RF communications equipment can affect the performance of the SMARTZ system. Install and use the system according to the information contained in this manual.

GLOSSARY

CE:	Conformité Européenne
FCC:	Federal Communications Commission
ID	Identification
IEC:	International Electrotechnical Commission
ISO:	International Organization for Standardization
IT:	Information Technology
MAC Address	Media Access Control Address
RCM:	Regulatory Compliance Mark
RF	Radio Frequency
SAS:	Smart Alert System
URL	Uniform Resource Locator
WEEE	Waste Electrical and Electronic Equipment

List of Figures

Figure 1 SMARTZ sensor pad and pod.....	16
Figure 2 SMARTZ pod	17
Figure 3 SMARTZ app.....	18
Figure 4 Overview of the SMARTZ app Time-To-Change status.....	18
Figure 5 SMARTZ network	19
Figure 7 SMARTZ pod	20
Figure 10 SMARTZ system Usage Warning.....	33



MADE IN AUSTRALIA by Simavita Ltd., Suite 2.02, Level 2, 54 Miller St, North Sydney, NSW 2060, Australia.

See www.smartzhealth.com for more information.