



FCC TEST REPORT

REPORT NO.: RF950113L15
MODEL NO.: H70
RECEIVED: Jan. 16, 2006
TESTED: Feb. 06 ~ Feb. 15, 2006
ISSUED: Feb. 17, 2006

APPLICANT: ELITEGROUP COMPUTER SYSTEMS
CO., LTD.

ADDRESS: 2F. No. 240, Sec. 1, Nei Hu Road, Taipei,
Taiwan 114, R.O.C.

ISSUED BY: Advance Data Technology Corporation

LAB ADDRESS: No. 47, 14th Ling, Chia Pau Tsuen, Lin Kou
Hsiang 244, Taipei Hsien, Taiwan, R.O.C.

TEST LOCATION: No. 19, Hwa Ya 2nd Rd., Wen Hwa Tsuen, Kwei
Shan Hsiang, Taoyuan Hsien 333, Taiwan,
R.O.C.

This test report consists of 146 pages in total. It may be duplicated completely for legal use with the approval of the applicant. It should not be reproduced except in full, without the written approval of our laboratory. The client should not use it to claim product endorsement by CNLA, A2LA or any government agencies. The test results in the report only apply to the tested sample.



No. 2177-01



0528

Table of Contents

1.	CERTIFICATION	6
2.	SUMMARY OF TEST RESULTS.....	7
2.1	MEASUREMENT UNCERTAINTY	8
3.	GENERAL INFORMATION	9
3.1	GENERAL DESCRIPTION OF EUT.....	9
3.2	DESCRIPTION OF TEST MODES.....	11
3.2.1	CONFIGURATION OF SYSTEM UNDER TEST.....	12
3.2.2	TEST MODE APPLICABILITY AND TESTED CHANNEL DETAIL	13
3.3	GENERAL DESCRIPTION OF APPLIED STANDARDS.....	17
3.4	DESCRIPTION OF SUPPORT UNITS.....	17
4.	TEST TYPES AND RESULTS (FOR WIRELESS FUNCTION)	18
4.1	CONDUCTED EMISSION MEASUREMENT.....	18
4.1.1	LIMITS OF CONDUCTED EMISSION MEASUREMENT	18
4.1.2	TEST INSTRUMENTS	18
4.1.3	TEST PROCEDURES	19
4.1.4	DEVIATION FROM TEST STANDARD	19
4.1.5	TEST SETUP	20
4.1.6	EUT OPERATING CONDITIONS.....	20
4.1.7	TEST RESULTS	21
4.2	RADIATED EMISSION MEASUREMENT.....	39
4.2.1	LIMITS OF RADIATED EMISSION MEASUREMENT	39
4.2.2	TEST INSTRUMENTS	40
4.2.3	TEST PROCEDURES	41
4.2.4	DEVIATION FROM TEST STANDARD	41
4.2.5	TEST SETUP	42
4.2.6	EUT OPERATING CONDITIONS.....	42
4.2.7	TEST RESULTS	43
4.3	6dB BANDWIDTH MEASUREMENT	52
4.3.1	LIMITS OF 6dB BANDWIDTH MEASUREMENT	52
4.3.2	TEST INSTRUMENTS	52
4.3.3	TEST PROCEDURE	53
4.3.4	DEVIATION FROM TEST STANDARD	53
4.3.5	TEST SETUP	53
4.3.6	EUT OPERATING CONDITIONS.....	53
4.3.7	TEST RESULTS	54
4.4	MAXIMUM PEAK OUTPUT POWER.....	60
4.4.1	LIMITS OF MAXIMUM PEAK OUTPUT POWER MEASUREMENT	60



4.4.2	INSTRUMENTS.....	60
4.4.1	TEST PROCEDURES.....	61
4.4.2	DEVIATION FROM TEST STANDARD.....	61
4.4.3	TEST SETUP.....	61
4.4.4	EUT OPERATING CONDITIONS.....	61
4.4.3	TEST RESULTS.....	62
4.5	POWER SPECTRAL DENSITY MEASUREMENT.....	63
4.5.1	LIMITS OF POWER SPECTRAL DENSITY MEASUREMENT.....	63
4.5.2	TEST INSTRUMENTS.....	63
4.5.3	TEST PROCEDURE.....	64
4.5.4	DEVIATION FROM TEST STANDARD.....	64
4.5.5	TEST SETUP.....	64
4.5.6	EUT OPERATING CONDITION.....	64
4.5.7	TEST RESULTS.....	65
4.6	BAND EDGES MEASUREMENT.....	71
4.6.1	LIMITS OF BAND EDGES MEASUREMENT.....	71
4.6.2	TEST INSTRUMENTS.....	71
4.6.3	TEST PROCEDURE.....	71
4.6.4	DEVIATION FROM TEST STANDARD.....	71
4.6.5	EUT OPERATING CONDITION.....	71
4.6.6	TEST RESULTS.....	72
4.7	ANTENNA REQUIREMENT.....	80
4.7.1	STANDARD APPLICABLE.....	80
4.7.2	ANTENNA CONNECTED CONSTRUCTION.....	80
5.	TEST TYPES AND RESULTS (FOR BLUETOOTH).....	81
5.1.1	CONDUCTED EMISSION MEASUREMENT.....	81
5.1.2	LIMITS OF CONDUCTED EMISSION MEASUREMENT.....	81
5.1.3	TEST INSTRUMENTS.....	81
5.1.4	TEST PROCEDURES.....	82
5.1.5	DEVIATION FROM TEST STANDARD.....	82
5.1.6	TEST SETUP.....	83
5.1.7	EUT OPERATING CONDITIONS.....	83
5.1.8	TEST RESULTS.....	84
5.2	RADIATED EMISSION MEASUREMENT.....	102
5.2.1	LIMITS OF RADIATED EMISSION MEASUREMENT.....	102
5.2.2	TEST INSTRUMENTS.....	103
5.2.3	TEST PROCEDURES.....	104
5.2.4	DEVIATION FROM TEST STANDARD.....	104
5.2.5	TEST SETUP.....	105
5.2.6	EUT OPERATING CONDITIONS.....	105
5.2.7	TEST RESULTS.....	106



5.3	NUMBER OF HOPPING FREQUENCY USED.....	112
5.3.1	LIMIT OF HOPPING FREQUENCY USED	112
5.3.2	TEST INSTRUMENTS	112
5.3.3	TEST PROCEDURES	112
5.3.4	DEVIATION FROM TEST STANDARD	113
5.3.5	TEST SETUP	113
5.3.6	TEST RESULTS	113
5.4	DWELL TIME ON EACH CHANNEL	115
5.4.1	LIMIT OF DWELL TIME USED	115
5.4.2	TEST INSTRUMENTS	115
5.4.3	TEST PROCEDURES	115
5.4.4	DEVIATION FROM TEST STANDARD	115
5.4.5	TEST SETUP	116
5.4.6	TEST RESULTS	116
5.5	CHANNEL BANDWIDTH.....	120
5.5.1	LIMITS OF CHANNEL BANDWIDTH	120
5.5.2	TEST INSTRUMENTS	120
5.5.3	TEST PROCEDURE	120
5.5.4	DEVIATION FROM TEST STANDARD	120
5.5.5	TEST SETUP	121
5.5.6	EUT OPERATING CONDITION	121
5.5.7	TEST RESULTS	122
5.6	HOPPING CHANNEL SEPARATION	125
5.6.1	LIMIT OF HOPPING CHANNEL SEPARATION.....	125
5.6.2	TEST INSTRUMENTS	125
5.6.3	TEST PROCEDURES	125
5.6.4	DEVIATION FROM TEST STANDARD	125
5.6.5	TEST SETUP	125
5.6.6	TEST RESULTS	126
5.7	MAXIMUM PEAK OUTPUT POWER	129
5.7.1	LIMITS OF MAXIMUM PEAK OUTPUT POWER MEASUREMENT	129
5.7.2	TEST INSTRUMENTS	129
5.7.3	TEST PROCEDURES	129
5.7.4	DEVIATION FROM TEST STANDARD	129
5.7.5	TEST SETUP	130
5.7.6	EUT OPERATING CONDITION	130
5.7.7	TEST RESULTS	131
5.8	BAND EDGES MEASUREMENT	134
5.8.1	LIMITS OF BAND EDGES MEASUREMENT	134
5.8.2	TEST INSTRUMENTS	134
5.8.3	TEST PROCEDURE	134



5.8.4	DEVIATION FROM TEST STANDARD	134
5.8.5	EUT OPERATING CONDITION	134
5.8.6	TEST RESULTS	135
5.9	ANTENNA REQUIREMENT	138
5.9.1	STANDARD APPLICABLE	138
5.9.2	ANTENNA CONNECTED CONSTRUCTION	138
6.	PHOTOGRAPHS OF THE TEST CONFIGURATION	139
7.	INFORMATION ON THE TESTING LABORATORIES.....	145



1. CERTIFICATION

PRODUCT: Notebook

MODEL: H70

BRAND: ECS

APPLICANT: ELITEGROUP COMPUTER SYSTEMS CO., LTD.

TEST SAMPLE: ENGINEERING SAMPLE

TESTED: Feb. 06 ~ Feb. 15, 2006

STANDARDS: FCC Part 15, Subpart C (Section 15.247),
ANSI C63.4-2003

The above equipment has been tested by **Advance Data Technology Corporation**, and found compliance with the requirement of the above standards. The test record, data evaluation & Equipment Under Test (EUT) configurations represented herein are true and accurate accounts of the measurements of the sample's EMC characteristics under the conditions specified in this report.

PREPARED BY : Wendy Liao , **DATE:** Feb. 17, 2006
Wendy Liao

TECHNICAL ACCEPTANCE : Long Chen , **DATE:** Feb. 17, 2006
Responsible for RF Long Chen

APPROVED BY : Gary Chang , **DATE:** Feb. 17, 2006
Gary Chang / Supervisor

2. SUMMARY OF TEST RESULTS

The EUT has been tested according to the following specifications:

For WLAN Function

APPLIED STANDARD: FCC Part 15, Subpart C (Section 15.247)			
Standard Section	Test Type and Limit	Result	Remark
15.207	AC Power Conducted Emission	PASS	Meet the requirement of limit. Minimum passing margin is -14.89dB at 0.150MHz
15.247(a)(2)	Spectrum Bandwidth of a Direct Sequence Spread Spectrum System Limit: min. 500kHz	PASS	Meet the requirement of limit.
15.247(b)	Maximum Peak Output Power Limit: max. 30dBm	PASS	Meet the requirement of limit.
15.247(d)	Radiated Emissions Limit: Table 15.209	PASS	Meet the requirement of limit. Minimum passing margin is -2.27dB at 7386.00MHz
15.247(e)	Power Spectral Density Limit: max. 8dBm	PASS	Meet the requirement of limit.
15.247(d)	Band Edge Measurement Limit: 20dB less than the peak value of fundamental frequency	PASS	Meet the requirement of limit.

For Bluetooth Function

APPLIED STANDARD: FCC Part 15, Subpart C			
Standard Section	Test Type and Limit	Result	Remark
15.207	AC Power Conducted Emission	PASS	Meet the requirement of limit Minimum passing margin is -16.80dB at 0.213MHz
15.247 (a) (1) (iii)	Number of Hopping Frequency Used Spec.: At least 15 channels	PASS	Meet the requirement of limit
15.247 (a) (1) (iii)	Dwell Time on Each Channel Spec.: Max. 0.4 second within 31.6 second	PASS	Meet the requirement of limit
15.247 (a) (1)	Hopping Channel Separation Spec. : Min. 25 kHz or 20 dB bandwidth, which ever is greater	PASS	Meet the requirement of limit
15.247 (a) (1)	Spectrum Bandwidth of a Frequency Hopping Sequence Spread Spectrum System	NA	NA
15.247 (b)	Maximum Peak Output Power Spec.: max. 30dBm	PASS	Meet the requirement of limit
15.247 (d)	Transmitter Radiated Emissions Spec.: Table 15.209	PASS	Meet the requirement of limit Minimum passing margin is -3.42dB at 78.80MHz
15.247 (d)	Band Edge Measurement	PASS	Meet the requirement of limit

2.1 MEASUREMENT UNCERTAINTY

Where relevant, the following measurement uncertainty levels have been estimated for tests performed on the EUT as specified in CISPR 16-4:

Measurement	Frequency	Uncertainty
Conducted emissions	9kHz~30MHz	2.44 dB
Radiated emissions	30MHz ~ 200MHz	3.55 dB
	200MHz ~ 1000MHz	3.58 dB
	1GHz ~ 18GHz	1.10 dB
	18GHz ~ 40GHz	0.91 dB

This uncertainty represents an expanded uncertainty expressed at approximately the 95% confidence level using a coverage factor of k=2.

3. GENERAL INFORMATION

3.1 GENERAL DESCRIPTION OF EUT

EUT	Notebook
MODEL NO.	H70
FCC ID	SA6H70QBGXB
POWER SUPPLY	19.0Vdc or 20Vdc from AC Adapters
MODULATION TYPE	Wireless LAN: CCK, DQPSK, DBPSK for DSSS 64QAM, 16QAM, QPSK, BPSK for OFDM Bluetooth: GFSK for FHSS
MODULATION TECHNOLOGY	DSSS, OFDM, FHSS
TRANSFER RATE	Wireless LAN: 802.11b: 11/5.5/2/1Mbps 802.11g: 54/48/36/24/18/12/9/6Mbps Bluetooth: 723Kbps
FREQUENCY RANGE	Wireless LAN: 802.11b & 802.11g: 2.412 ~ 2.462GHz Bluetooth: 2.402 ~ 2.480GHz
NUMBER OF CHANNEL	Wireless LAN: 802.11b & 802.11g: 11 Bluetooth: 79
CHANNEL SPACING	Wireless LAN: 802.11b & 802.11g: 5MHz Bluetooth: 1MHz
OUTPUT POWER	Wireless LAN: 43.451mW Bluetooth: 1.521mW
ANTENNA TYPE	Wireless LAN: PIFA antenna with 0.43dBi gain Bluetooth: PIFA antenna with -2.13321dBi gain
DATA CABLE	NA
I/O PORTS	Refer to user's manual
ASSOCIATED DEVICES	NA



NOTE:

1. The EUT is a Notebook with Wireless LAN and Bluetooth functions.
2. The adapter were operated with following power adapters:

BRAND:	LI SHIN INTERNATIONAL ENTERPRISE CORP.
MODEL:	0335A1965
INPUT:	100-240Vac, 50-60Hz, 1.7A
OUTPUT:	19Vdc, 3.42A
POWER LINE:	AC 1.8m non-shielded cable without core DC 1.6m non-shielded cable with one core

BRAND:	LITE-ON TECHNOLOGY CORPORATION
MODEL:	PA-1650-02
INPUT:	100-240Vac, 50-60Hz, 1.6A
OUTPUT:	19Vdc, 3.42A
POWER LINE:	AC 1.8m non-shielded cable without core DC 1.6m non-shielded cable with one core

BRAND:	LITE-ON TECHNOLOGY CORPORATION
MODEL:	PA-1500-01
INPUT:	100-240Vac, 50-60Hz, 1.5A
OUTPUT:	20Vdc, 2.5A
POWER LINE:	AC 1.8m non-shielded cable without core DC 1.6m non-shielded cable with one core

3. The EUT operates in the 2.4GHz frequency spectrum and complies with 802.11b & 802.11g techniques.
4. The printed antenna printed on the bluetooth module is workless.
5. The above EUT information was declared by the manufacturer and for more detailed features description, please refer to the manufacturer's specifications or User's Manual.

3.2 DESCRIPTION OF TEST MODES

Since the EUT is considered a portable unit, it was pre-tested on the positioned of each 3 axis. The worst case was found when positioned on Y-plane. Therefore only the test data of this Y-plane was used for radiated test.

Operated in 2400 ~ 2483.5MHz band:

11 channels are provided to the EUT for Wireless LAN function:

CHANNEL	FREQUENCY	CHANNEL	FREQUENCY
1	2412 MHz	7	2442 MHz
2	2417 MHz	8	2447 MHz
3	2422 MHz	9	2452 MHz
4	2427 MHz	10	2457 MHz
5	2432 MHz	11	2462 MHz
6	2437 MHz		

79 channels are provided to this EUT for Bluetooth function:

CHANNEL	FREQ. (MHz)	CHANNEL	FREQ. (MHz)	CHANNEL	FREQ. (MHz)	CHANNEL	FREQ. (MHz)
0	2402	20	2422	40	2442	60	2462
1	2403	21	2423	41	2443	61	2463
2	2404	22	2424	42	2444	62	2464
3	2405	23	2425	43	2445	63	2465
4	2406	24	2426	44	2446	64	2466
5	2407	25	2427	45	2447	65	2467
6	2408	26	2428	46	2448	66	2468
7	2409	27	2429	47	2449	67	2469
8	2410	28	2430	48	2450	68	2470
9	2411	29	2431	49	2451	69	2471
10	2412	30	2431	50	2452	70	2472
11	2413	31	2433	51	2453	71	2473
12	2414	32	2434	52	2454	72	2474
13	2415	33	2435	53	2455	73	2475
14	2416	34	2436	54	2456	74	2476
15	2417	35	2437	55	2457	75	2477
16	2418	36	2438	56	2458	76	2478
17	2419	37	2439	57	2459	77	2479
18	2420	38	2440	58	2460	78	2480
19	2421	39	2441	59	2461		

3.2.1 CONFIGURATION OF SYSTEM UNDER TEST

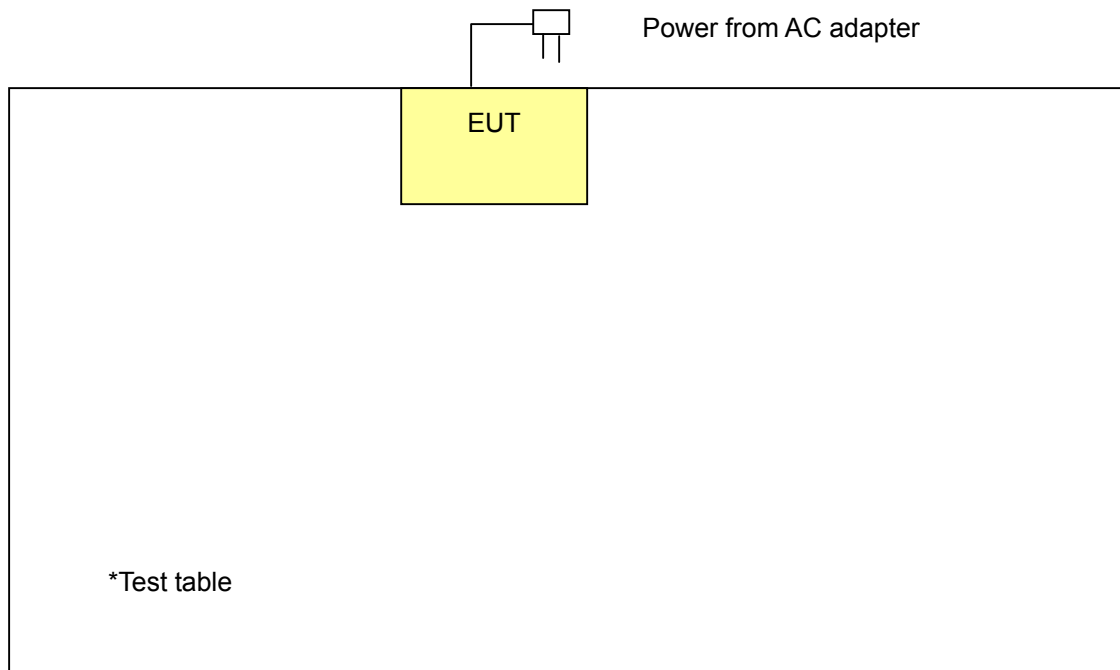

3.2.2 TEST MODE APPLICABILITY AND TESTED CHANNEL DETAIL

FOR WIRELESS LAN FUNCTION:

EUT configure mode	Applicable to				Description
	PLC	RE<1G	RE≥1G	APCM	
A	√	√	√	√	For adapter: 0335A1965
B	√	√	-	-	For adapter: PA-1650-02
C	√	√	-	-	For adapter: PA-1500-01

Where PLC: Power Line Conducted Emission RE<1G RE: Radiated Emission below 1GHz
 RE≥1G: Radiated Emission above 1GHz APCM: Antenna Port Conducted Measurement

NOTE: “-“ means no effect.

Power Line Conducted Emission Test:

- Pre-Scan has been conducted to determine the worst-case mode from all possible combinations between available modulations, data rates and antenna ports (if EUT with antenna diversity architecture).
- Following channel(s) was (were) selected for the final test as listed below.

EUT CONFIGURE MODE	Mode	AVAILABLE CHANNEL	TESTED CHANNEL	MODULATION TECHNOLOGY	MODULATION TYPE	DATA RATE (Mbps)
A	802.11g	1 to 11	1, 6, 11	OFDM	BPSK	6
B	802.11g	1 to 11	1, 6, 11	OFDM	BPSK	6
C	802.11g	1 to 11	1, 6, 11	OFDM	BPSK	6

Radiated Emission Test (Below 1 GHz):

- Pre-Scan has been conducted to determine the worst-case mode from all possible combinations between available modulations, data rates, antenna ports (if EUT with antenna diversity architecture), and X, Y and Z Axis.
- Following channel(s) was (were) selected for the final test as listed below.

EUT CONFIGURE MODE	MODE	AVAILABLE CHANNEL	TESTED CHANNEL	MODULATION TECHNOLOGY	MODULATION TYPE	DATA RATE (Mbps)	AXIS
A	802.11g	1 to 11	11	OFDM	BPSK	6	Y
B	802.11g	1 to 11	11	OFDM	BPSK	6	Y
C	802.11g	1 to 11	11	OFDM	BPSK	6	Y



Radiated Emission Test (Above 1 GHz):

- Pre-Scan has been conducted to determine the worst-case mode from all possible combinations between available modulations, data rates and antenna ports (if EUT with antenna diversity architecture), and X, Y and Z Axis.
- Following channel(s) was (were) selected for the final test as listed below.

EUT CONFIGURE MODE	MODE	AVAILABLE CHANNEL	TESTED CHANNEL	MODULATION TECHNOLOGY	MODULATION TYPE	DATA RATE (Mbps)	AXIS
A	802.11b	1 to 11	1, 6, 11	DSSS	DBPSK	1	Y
A	802.11g	1 to 11	1, 6, 11	OFDM	BPSK	6	Y

Bandedge Measurement:

- Pre-Scan has been conducted to determine the worst-case mode from all possible combinations between available modulations, data rates and antenna ports (if EUT with antenna diversity architecture).
- Following channel(s) was (were) selected for the final test as listed below.

MODE	AVAILABLE CHANNEL	TESTED CHANNEL	MODULATION TECHNOLOGY	MODULATION TYPE	DATA RATE (Mbps)
802.11b	1 to 11	1, 11	DSSS	DBPSK	1
802.11g	1 to 11	1, 11	OFDM	BPSK	6

Antenna Port Conducted Measurement:

- Pre-Scan has been conducted to determine the worst-case mode from all possible combinations between available modulations, data rates and antenna ports (if EUT with antenna diversity architecture).
- Following channel(s) was (were) selected for the final test as listed below.

MODE	AVAILABLE CHANNEL	TESTED CHANNEL	MODULATION TECHNOLOGY	MODULATION TYPE	DATA RATE (Mbps)
802.11b	1 to 11	1, 6, 11	DSSS	DBPSK	1
802.11g	1 to 11	1, 6, 11	OFDM	BPSK	6

FOR BLUETOOTH FUNCTION:

EUT configure mode	Applicable to				Description
	PLC	RE<1G	RE≥1G	APCM	
A	√	√	√	√	For adapter: 0335A1965
B	√	√	-	-	For adapter: PA-1650-02
C	√	√	-	-	For adapter: PA-1500-01

Where PLC: Power Line Conducted Emission RE<1G RE: Radiated Emission below 1GHz
 RE≥1G: Radiated Emission above 1GHz APCM: Antenna Port Conducted Measurement

NOTE: “-“ means no effect.

Power Line Conducted Emission Test:

- Pre-Scan has been conducted to determine the worst-case mode from all possible combinations between available modulations, data rates and antenna ports (if EUT with antenna diversity architecture), and packet types.
- Following channel(s) was (were) selected for the final test as listed below.

EUT CONFIGURE MODE	AVAILABLE CHANNEL	TESTED CHANNEL	MODULATION TECHNOLOGY	MODULATION TYPE	PACKET TYPE
A	0 to 78	0, 39, 78	FHSS	GFSK	DH5
B	0 to 78	0, 39, 78	FHSS	GFSK	DH5
C	0 to 78	0, 39, 78	FHSS	GFSK	DH5

Radiated Emission Test (Below 1 GHz):

- Pre-Scan has been conducted to determine the worst-case mode from all possible combinations between available modulations, data rates, antenna ports (if EUT with antenna diversity architecture), X, Y, Z Axis, and packet types.
- Following channel(s) was (were) selected for the final test as listed below.

EUT CONFIGURE MODE	AVAILABLE CHANNEL	TESTED CHANNEL	MODULATION TECHNOLOGY	MODULATION TYPE	PACKET TYPE	AXIS
A	0 to 78	78	FHSS	GFSK	DH5	Y
B	0 to 78	78	FHSS	GFSK	DH5	Y
C	0 to 78	78	FHSS	GFSK	DH5	Y



Radiated Emission Test (Above 1 GHz):

- Pre-Scan has been conducted to determine the worst-case mode from all possible combinations between available modulations, data rates and antenna ports (if EUT with antenna diversity architecture), X, Y, Z Axis, and packet types.
- Following channel(s) was (were) selected for the final test as listed below.

EUT CONFIGURE MODE	AVAILABLE CHANNEL	TESTED CHANNEL	MODULATION TECHNOLOGY	MODULATION TYPE	PACKET TYPE	AXIS
A	0 to 78	0, 39, 78	FHSS	GFSK	DH5	Y

Bandedge Measurement:

- Pre-Scan has been conducted to determine the worst-case mode from all possible combinations between available modulations, data rates and antenna ports (if EUT with antenna diversity architecture).
- Following channel(s) was (were) selected for the final test as listed below.

AVAILABLE CHANNEL	TESTED CHANNEL	MODULATION TECHNOLOGY	MODULATION TYPE	PACKET TYPE
0 to 78	0, 78	FHSS	GFSK	DH5

Antenna Port Conducted Measurement:

- Pre-Scan has been conducted to determine the worst-case mode from all possible combinations between available modulations, data rates and antenna ports (if EUT with antenna diversity architecture).
- Following channel(s) was (were) selected for the final test as listed below.

AVAILABLE CHANNEL	TESTED CHANNEL	MODULATION TECHNOLOGY	MODULATION TYPE	PACKET TYPE
0 to 78	0, 39, 78	FHSS	GFSK	DH5



3.3 GENERAL DESCRIPTION OF APPLIED STANDARDS

The EUT is a RF product. According to the specifications of the manufacturer, it must comply with the requirements of the following standards:

FCC Part 15, Subpart C. (15.247)

ANSI C63.4-2003

All test items have been performed and recorded as per the above standards.

NOTE: The EUT is also considered as a kind of computer peripheral, because the connection to computer is necessary for typical use. It has been verified to comply with the requirements of FCC Part 15, Subpart B, Class B (DoC). The test report has been issued separately.

3.4 DESCRIPTION OF SUPPORT UNITS

NA

4. TEST TYPES AND RESULTS (FOR WIRELESS FUNCTION)

4.1 CONDUCTED EMISSION MEASUREMENT

4.1.1 LIMITS OF CONDUCTED EMISSION MEASUREMENT

FREQUENCY OF EMISSION (MHz)	CONDUCTED LIMIT (dB μ V)	
	Quasi-peak	Average
0.15-0.5	66 to 56	56 to 46
0.5-5	56	46
5-30	60	50

- NOTE:**
1. The lower limit shall apply at the transition frequencies.
 2. The limit decreases in line with the logarithm of the frequency in the range of 0.15 to 0.50 MHz.
 3. All emanations from a class A/B digital device or system, including any network of conductors and apparatus connected thereto, shall not exceed the level of field strengths specified above.

4.1.2 TEST INSTRUMENTS

DESCRIPTION & MANUFACTURER	MODEL NO.	SERIAL NO.	CALIBRATED UNTIL
Test Receiver ROHDE & SCHWARZ	ESCS30	100288	Nov. 02, 2006
RF signal cable Woken	5D-FB	Cable-HyC02-01	Jan. 06, 2007
LISN ROHDE & SCHWARZ	ESH2-Z5	100100	Jan. 09, 2007
LISN ROHDE & SCHWARZ	ESH3-Z5	100311	Jan. 22, 2007
Software ADT	ADT_Cond_V3	NA	NA

- NOTE:**
1. The calibration interval of the above test instruments is 12 months and the calibrations are traceable to NML/ROC and NIST/USA.
 2. The test was performed in HwaYa Shielded Room 3.
 3. The VCCI Site Registration No. is C-2047.

4.1.3 TEST PROCEDURES

- a. The EUT was placed 0.4 meters from the conducting wall of the shielded room with EUT being connected to the power mains through a line impedance stabilization network (LISN). Other support units were connected to the power mains through another LISN. The two LISNs provide 50 ohm/ 50uH of coupling impedance for the measuring instrument.
- b. Both lines of the power mains connected to the EUT were checked for maximum conducted interference.
- c. The frequency range from 150kHz to 30MHz was searched. Emission levels under (Limit - 20dB) was not recorded.

4.1.4 DEVIATION FROM TEST STANDARD

No deviation

4.1.5 TEST SETUP

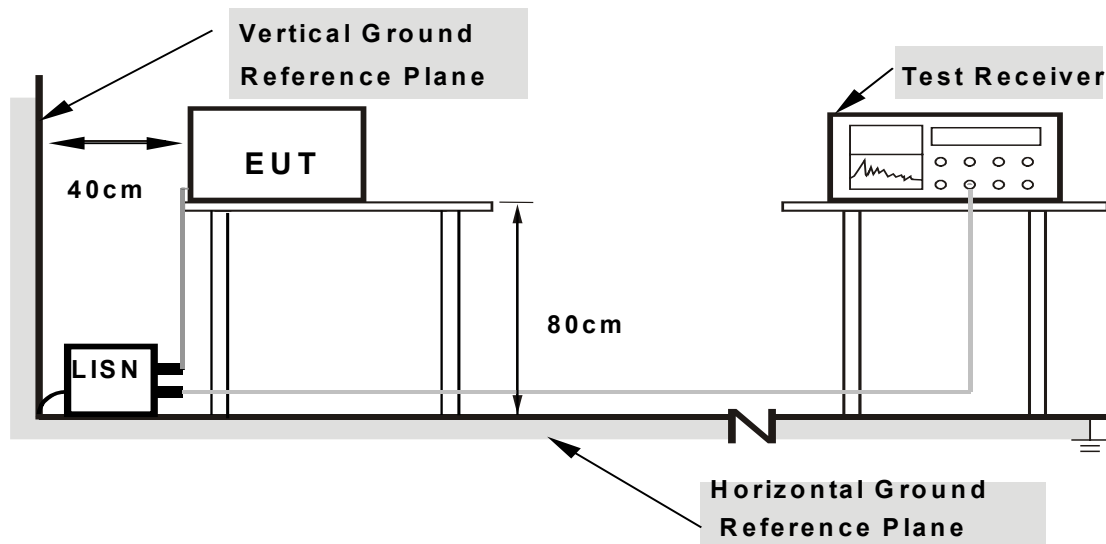

- Note:**
1. Support units were connected to second LISN.
 2. Both of LISNs (AMN) are 80 cm from EUT and at least 80 from other units and other metal planes

For the actual test configuration, please refer to the related item – Photographs of the Test Configuration.

4.1.6 EUT OPERATING CONDITIONS

- a. Placed the EUT on a testing table.
- b. The EUT ran a test program (provided by manufacturer) to enable all functions under transmission condition continuously at specific channel frequency.
- c. The EUT sent "H" messages to monitor.

4.1.7 TEST RESULTS

Conducted Worst-Case Data

EUT TEST CONDITION		MEASUREMENT DETAIL	
CHANNEL	Channel 1	PHASE	Line 1
MODULATION TYPE	BPSK	6dB BANDWIDTH	9 kHz
TRANSFER RATE	6Mbps	INPUT POWER (SYSTEM)	120Vac, 60 Hz
ENVIRONMENTAL CONDITIONS	20deg. C, 60%RH, 991hPa	TEST MODE	A
TESTED BY	Match Tsui		

No	Freq. [MHz]	Corr. Factor (dB)	Reading Value [dB (uV)]		Emission Level [dB (uV)]		Limit [dB (uV)]		Margin (dB)	
			Q.P.	AV.	Q.P.	AV.	Q.P.	AV.	Q.P.	AV.
			1	0.150	0.10	51.01	-	51.11	-	66.00
2	0.216	0.10	41.29	-	41.39	-	62.96	52.96	-21.57	-
3	0.943	0.19	27.74	-	27.93	-	56.00	46.00	-28.07	-
4	3.047	0.29	27.98	-	28.27	-	56.00	46.00	-27.73	-
5	4.359	0.38	26.27	-	26.65	-	56.00	46.00	-29.35	-
6	18.480	0.89	33.27	-	34.16	-	60.00	50.00	-25.84	-

- REMARKS:**
1. Q.P. and AV. are abbreviations of quasi-peak and average individually.
 2. "-": The Quasi-peak reading value also meets average limit and measurement with the average detector is unnecessary.
 3. The emission levels of other frequencies were very low against the limit.
 4. Margin value = Emission level - Limit value
 5. Correction factor = Insertion loss + Cable loss
 6. Emission Level = Correction Factor + Reading Value.

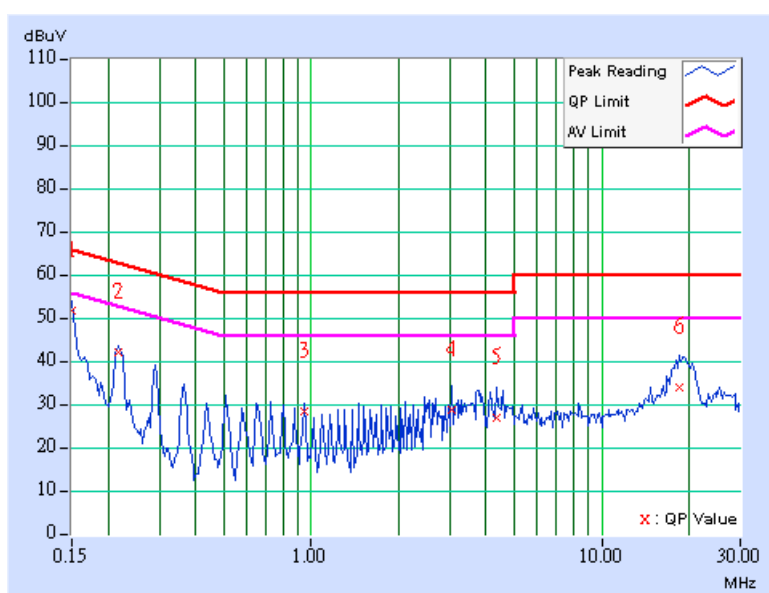

EUT TEST CONDITION		MEASUREMENT DETAIL	
CHANNEL	Channel 1	PHASE	Line 2
MODULATION TYPE	BPSK	6dB BANDWIDTH	9 kHz
TRANSFER RATE	6Mbps	INPUT POWER (SYSTEM)	120Vac, 60 Hz
ENVIRONMENTAL CONDITIONS	20deg. C, 60%RH, 991hPa	TEST MODE	A
TESTED BY	Match Tsui		

No	Freq. [MHz]	Corr. Factor (dB)	Reading Value [dB (uV)]		Emission Level [dB (uV)]		Limit [dB (uV)]		Margin (dB)	
			Q.P.	AV.	Q.P.	AV.	Q.P.	AV.	Q.P.	AV.
			1	0.150	0.10	50.58	-	50.68	-	66.00
2	0.216	0.10	41.22	-	41.32	-	62.96	52.96	-21.64	-
3	0.513	0.12	32.29	-	32.41	-	56.00	46.00	-23.59	-
4	0.943	0.19	28.49	-	28.68	-	56.00	46.00	-27.32	-
5	3.637	0.34	31.95	-	32.29	-	56.00	46.00	-23.71	-
6	19.008	0.93	28.81	-	29.74	-	60.00	50.00	-30.26	-

- REMARKS:**
1. Q.P. and AV. are abbreviations of quasi-peak and average individually.
 2. "-": The Quasi-peak reading value also meets average limit and measurement with the average detector is unnecessary.
 3. The emission levels of other frequencies were very low against the limit.
 4. Margin value = Emission level - Limit value
 5. Correction factor = Insertion loss + Cable loss
 6. Emission Level = Correction Factor + Reading Value.

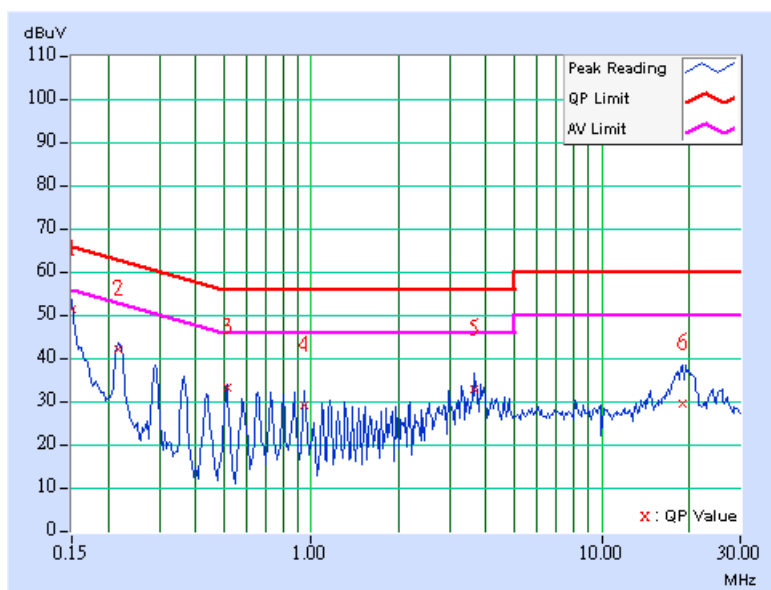

EUT TEST CONDITION		MEASUREMENT DETAIL	
CHANNEL	Channel 6	PHASE	Line 1
MODULATION TYPE	BPSK	6dB BANDWIDTH	9 kHz
TRANSFER RATE	6Mbps	INPUT POWER (SYSTEM)	120Vac, 60 Hz
ENVIRONMENTAL CONDITIONS	20deg. C, 60%RH, 991hPa	TEST MODE	A
TESTED BY	Match Tsui		

No	Freq. [MHz]	Corr. Factor [dB]	Reading Value [dB (uV)]		Emission Level [dB (uV)]		Limit [dB (uV)]		Margin (dB)	
			Q.P.	AV.	Q.P.	AV.	Q.P.	AV.	Q.P.	AV.
			1	0.150	0.10	50.28	-	50.38	-	66.00
2	0.220	0.10	40.22	-	40.32	-	62.81	52.81	-22.49	-
3	0.513	0.12	29.82	-	29.94	-	56.00	46.00	-26.06	-
4	1.246	0.20	20.52	-	20.72	-	56.00	46.00	-35.28	-
5	3.363	0.32	22.42	-	22.74	-	56.00	46.00	-33.26	-
6	18.551	0.89	30.19	-	31.08	-	60.00	50.00	-28.92	-

- REMARKS:**
1. Q.P. and AV. are abbreviations of quasi-peak and average individually.
 2. "-": The Quasi-peak reading value also meets average limit and measurement with the average detector is unnecessary.
 3. The emission levels of other frequencies were very low against the limit.
 4. Margin value = Emission level - Limit value
 5. Correction factor = Insertion loss + Cable loss
 6. Emission Level = Correction Factor + Reading Value.

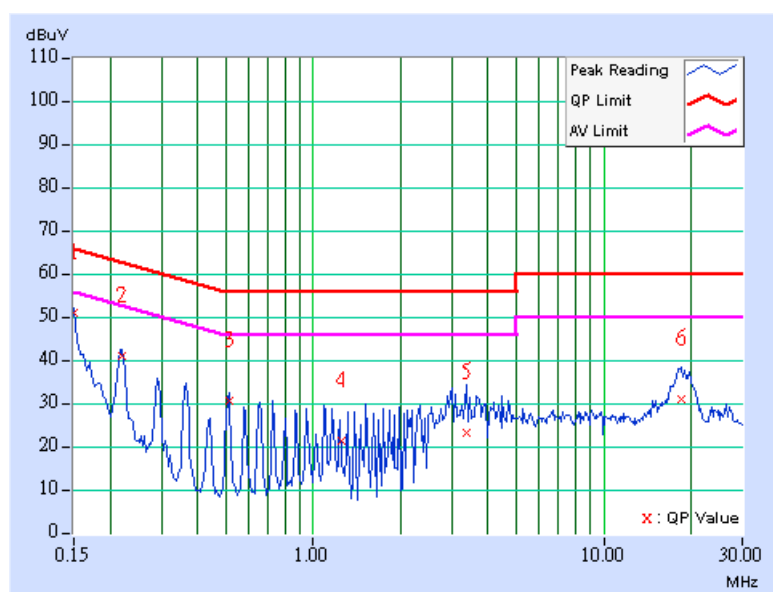

EUT TEST CONDITION		MEASUREMENT DETAIL	
CHANNEL	Channel 6	PHASE	Line 2
MODULATION TYPE	BPSK	6dB BANDWIDTH	9 kHz
TRANSFER RATE	6Mbps	INPUT POWER (SYSTEM)	120Vac, 60 Hz
ENVIRONMENTAL CONDITIONS	20deg. C, 60%RH, 991hPa	TEST MODE	A
TESTED BY	Match Tsui		

No	Freq. [MHz]	Corr. Factor (dB)	Reading Value [dB (uV)]		Emission Level [dB (uV)]		Limit [dB (uV)]		Margin (dB)	
			Q.P.	AV.	Q.P.	AV.	Q.P.	AV.	Q.P.	AV.
	1	0.150	0.10	47.91	-	48.01	-	66.00	56.00	-17.99
2	0.216	0.10	41.56	-	41.66	-	62.96	52.96	-21.30	-
3	0.365	0.10	31.57	-	31.67	-	58.62	48.62	-26.95	-
4	0.869	0.18	29.79	-	29.97	-	56.00	46.00	-26.03	-
5	3.477	0.33	30.94	-	31.27	-	56.00	46.00	-24.73	-
6	18.664	0.93	26.21	-	27.14	-	60.00	50.00	-32.86	-

- REMARKS:**
1. Q.P. and AV. are abbreviations of quasi-peak and average individually.
 2. "-": The Quasi-peak reading value also meets average limit and measurement with the average detector is unnecessary.
 3. The emission levels of other frequencies were very low against the limit.
 4. Margin value = Emission level - Limit value
 5. Correction factor = Insertion loss + Cable loss
 6. Emission Level = Correction Factor + Reading Value.

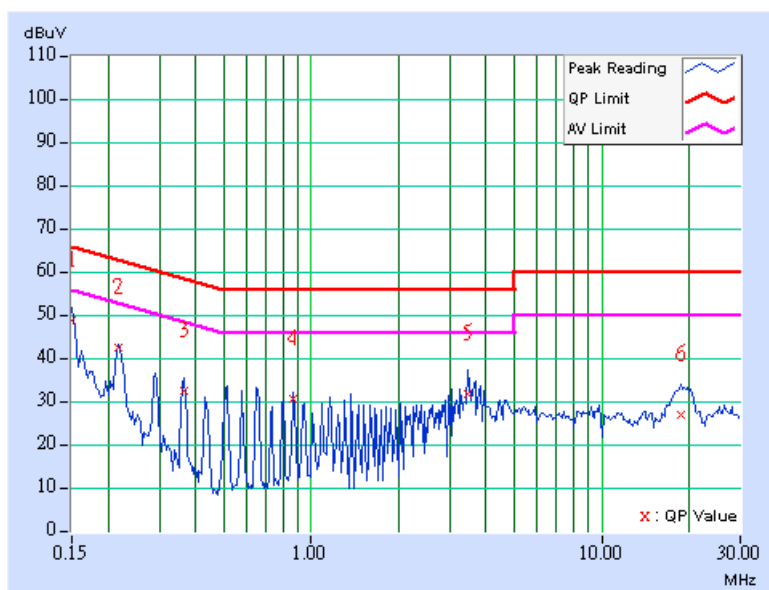

EUT TEST CONDITION		MEASUREMENT DETAIL	
CHANNEL	Channel 11	PHASE	Line 1
MODULATION TYPE	BPSK	6dB BANDWIDTH	9 kHz
TRANSFER RATE	6Mbps	INPUT POWER (SYSTEM)	120Vac, 60 Hz
ENVIRONMENTAL CONDITIONS	20deg. C, 60%RH, 991hPa	TEST MODE	A
TESTED BY	Match Tsui		

No	Freq. [MHz]	Corr. Factor (dB)	Reading Value [dB (uV)]		Emission Level [dB (uV)]		Limit [dB (uV)]		Margin (dB)	
			Q.P.	AV.	Q.P.	AV.	Q.P.	AV.	Q.P.	AV.
			1	0.150	0.10	45.87	-	45.97	-	66.00
2	0.216	0.10	41.36	-	41.46	-	62.96	52.96	-21.50	-
3	0.365	0.10	28.36	-	28.46	-	58.62	48.62	-30.16	-
4	0.650	0.14	29.97	-	30.11	-	56.00	46.00	-25.89	-
5	3.684	0.34	29.16	-	29.50	-	56.00	46.00	-26.50	-
6	19.141	0.92	28.39	-	29.31	-	60.00	50.00	-30.69	-

- REMARKS:**
1. Q.P. and AV. are abbreviations of quasi-peak and average individually.
 2. "-": The Quasi-peak reading value also meets average limit and measurement with the average detector is unnecessary.
 3. The emission levels of other frequencies were very low against the limit.
 4. Margin value = Emission level - Limit value
 5. Correction factor = Insertion loss + Cable loss
 6. Emission Level = Correction Factor + Reading Value.

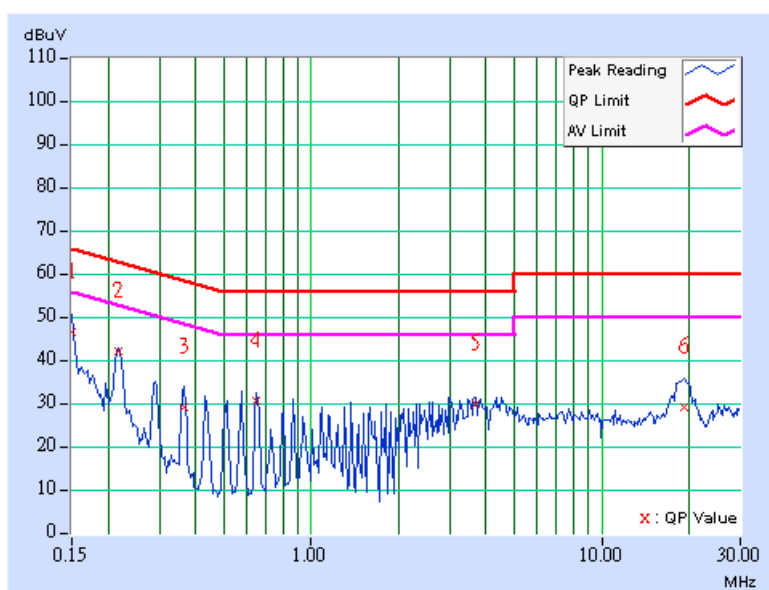

EUT TEST CONDITION		MEASUREMENT DETAIL	
CHANNEL	Channel 11	PHASE	Line 2
MODULATION TYPE	BPSK	6dB BANDWIDTH	9 kHz
TRANSFER RATE	6Mbps	INPUT POWER (SYSTEM)	120Vac, 60 Hz
ENVIRONMENTAL CONDITIONS	20deg. C, 60%RH, 991hPa	TEST MODE	A
TESTED BY	Match Tsui		

No	Freq. [MHz]	Corr. Factor (dB)	Reading Value [dB (uV)]		Emission Level [dB (uV)]		Limit [dB (uV)]		Margin (dB)	
			Q.P.	AV.	Q.P.	AV.	Q.P.	AV.	Q.P.	AV.
	1	0.150	0.10	44.78	-	44.88	-	66.00	56.00	-21.12
2	0.216	0.10	41.46	-	41.56	-	62.96	52.96	-21.40	-
3	0.576	0.13	32.91	-	33.04	-	56.00	46.00	-22.96	-
4	0.865	0.18	30.45	-	30.63	-	56.00	46.00	-25.37	-
5	3.770	0.35	26.28	-	26.63	-	56.00	46.00	-29.37	-
6	19.930	0.96	24.91	-	25.87	-	60.00	50.00	-34.13	-

- REMARKS:**
1. Q.P. and AV. are abbreviations of quasi-peak and average individually.
 2. "-": The Quasi-peak reading value also meets average limit and measurement with the average detector is unnecessary.
 3. The emission levels of other frequencies were very low against the limit.
 4. Margin value = Emission level - Limit value
 5. Correction factor = Insertion loss + Cable loss
 6. Emission Level = Correction Factor + Reading Value.

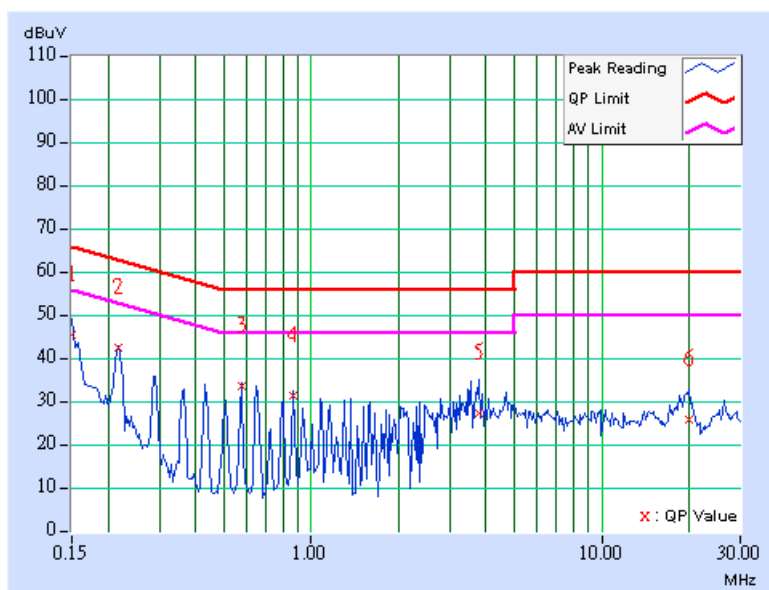

EUT TEST CONDITION		MEASUREMENT DETAIL	
CHANNEL	Channel 1	PHASE	Line 1
MODULATION TYPE	BPSK	6dB BANDWIDTH	9 kHz
TRANSFER RATE	6Mbps	INPUT POWER (SYSTEM)	120Vac, 60 Hz
ENVIRONMENTAL CONDITIONS	20deg. C, 60%RH, 991hPa	TEST MODE	B
TESTED BY	Match Tsui		

No	Freq. [MHz]	Corr. Factor [dB]	Reading Value [dB (uV)]		Emission Level [dB (uV)]		Limit [dB (uV)]		Margin (dB)	
			Q.P.	AV.	Q.P.	AV.	Q.P.	AV.	Q.P.	AV.
			1	0.209	0.10	46.55	-	46.65	-	63.26
2	0.283	0.10	40.31	-	40.41	-	60.73	50.73	-20.32	-
3	0.353	0.10	33.70	-	33.80	-	58.89	48.89	-25.09	-
4	0.423	0.10	33.79	-	33.89	-	57.38	47.38	-23.49	-
5	2.887	0.28	26.05	-	26.33	-	56.00	46.00	-29.67	-
6	3.945	0.37	32.36	-	32.73	-	56.00	46.00	-23.27	-

- REMARKS:**
1. Q.P. and AV. are abbreviations of quasi-peak and average individually.
 2. "-": The Quasi-peak reading value also meets average limit and measurement with the average detector is unnecessary.
 3. The emission levels of other frequencies were very low against the limit.
 4. Margin value = Emission level - Limit value
 5. Correction factor = Insertion loss + Cable loss
 6. Emission Level = Correction Factor + Reading Value.

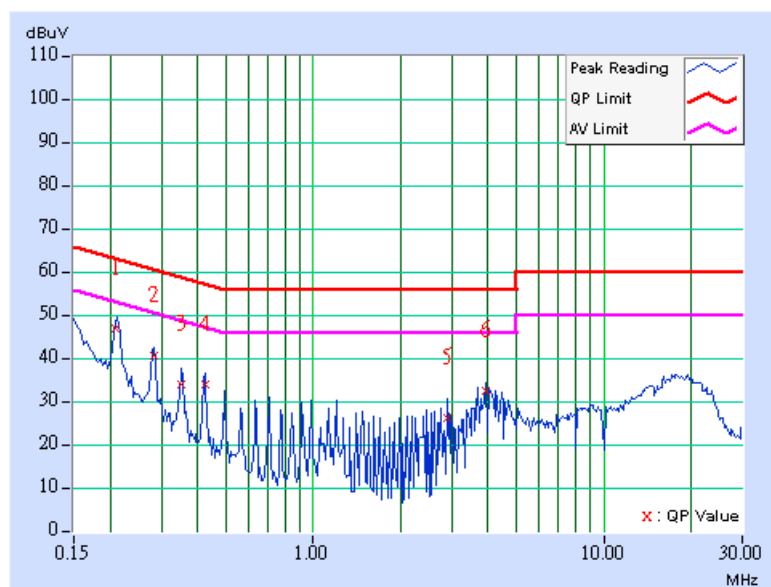

EUT TEST CONDITION		MEASUREMENT DETAIL	
CHANNEL	Channel 1	PHASE	Line 2
MODULATION TYPE	BPSK	6dB BANDWIDTH	9 kHz
TRANSFER RATE	6Mbps	INPUT POWER (SYSTEM)	120Vac, 60 Hz
ENVIRONMENTAL CONDITIONS	20deg. C, 60%RH, 991hPa	TEST MODE	B
TESTED BY	Match Tsui		

No	Freq. [MHz]	Corr. Factor (dB)	Reading Value [dB (uV)]		Emission Level [dB (uV)]		Limit [dB (uV)]		Margin (dB)	
			Q.P.	AV.	Q.P.	AV.	Q.P.	AV.	Q.P.	AV.
			1	0.213	0.10	46.43	-	46.53	-	63.11
2	0.283	0.10	38.23	-	38.33	-	60.73	50.73	-22.40	-
3	0.353	0.10	33.69	-	33.79	-	58.89	48.89	-25.10	-
4	2.395	0.23	28.57	-	28.80	-	56.00	46.00	-27.20	-
5	3.453	0.32	27.70	-	28.02	-	56.00	46.00	-27.98	-
6	4.152	0.37	31.95	-	32.32	-	56.00	46.00	-23.68	-

- REMARKS:**
1. Q.P. and AV. are abbreviations of quasi-peak and average individually.
 2. "-": The Quasi-peak reading value also meets average limit and measurement with the average detector is unnecessary.
 3. The emission levels of other frequencies were very low against the limit.
 4. Margin value = Emission level - Limit value
 5. Correction factor = Insertion loss + Cable loss
 6. Emission Level = Correction Factor + Reading Value.

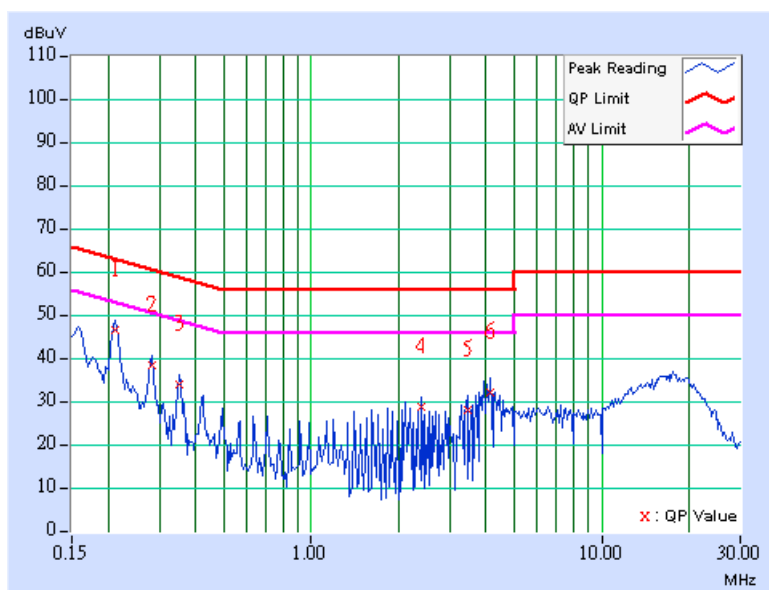

EUT TEST CONDITION		MEASUREMENT DETAIL	
CHANNEL	Channel 6	PHASE	Line 1
MODULATION TYPE	BPSK	6dB BANDWIDTH	9 kHz
TRANSFER RATE	6Mbps	INPUT POWER (SYSTEM)	120Vac, 60 Hz
ENVIRONMENTAL CONDITIONS	20deg. C, 60%RH, 991hPa	TEST MODE	B
TESTED BY	Match Tsui		

No	Freq. [MHz]	Corr. Factor [dB]	Reading Value [dB (uV)]		Emission Level [dB (uV)]		Limit [dB (uV)]		Margin (dB)	
			Q.P.	AV.	Q.P.	AV.	Q.P.	AV.	Q.P.	AV.
			1	0.213	0.10	46.70	-	46.80	-	63.11
2	0.283	0.10	40.50	-	40.60	-	60.73	50.73	-20.13	-
3	0.353	0.10	34.33	-	34.43	-	58.89	48.89	-24.46	-
4	0.423	0.10	34.43	-	34.53	-	57.38	47.38	-22.85	-
5	0.494	0.12	29.42	-	29.54	-	56.10	46.10	-26.57	-
6	4.227	0.37	32.87	-	33.24	-	56.00	46.00	-22.76	-

- REMARKS:**
1. Q.P. and AV. are abbreviations of quasi-peak and average individually.
 2. "-": The Quasi-peak reading value also meets average limit and measurement with the average detector is unnecessary.
 3. The emission levels of other frequencies were very low against the limit.
 4. Margin value = Emission level - Limit value
 5. Correction factor = Insertion loss + Cable loss
 6. Emission Level = Correction Factor + Reading Value.

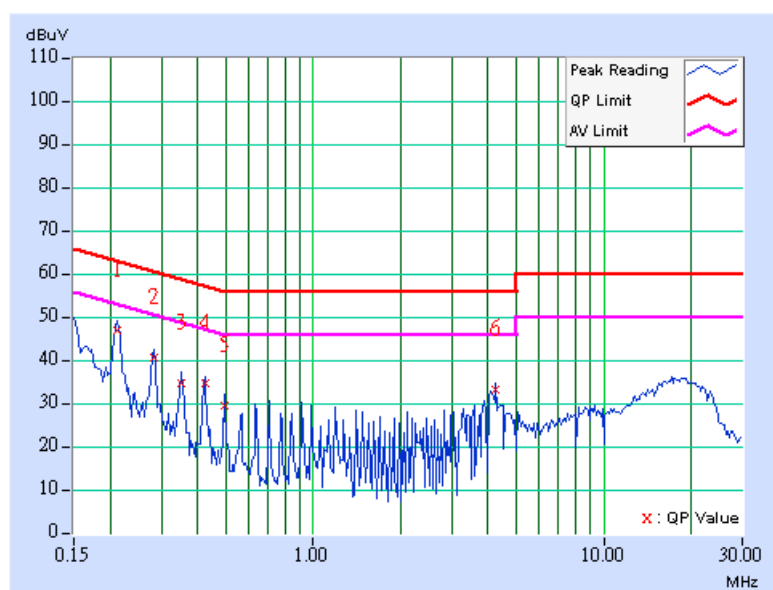

EUT TEST CONDITION		MEASUREMENT DETAIL	
CHANNEL	Channel 6	PHASE	Line 2
MODULATION TYPE	BPSK	6dB BANDWIDTH	9 kHz
TRANSFER RATE	6Mbps	INPUT POWER (SYSTEM)	120Vac, 60 Hz
ENVIRONMENTAL CONDITIONS	20deg. C, 60%RH, 991hPa	TEST MODE	B
TESTED BY	Match Tsui		

No	Freq. [MHz]	Corr. Factor (dB)	Reading Value [dB (uV)]		Emission Level [dB (uV)]		Limit [dB (uV)]		Margin (dB)	
			Q.P.	AV.	Q.P.	AV.	Q.P.	AV.	Q.P.	AV.
	1	0.213	0.10	46.33	-	46.43	-	63.11	53.11	-16.68
2	0.283	0.10	38.13	-	38.23	-	60.73	50.73	-22.50	-
3	0.349	0.10	32.01	-	32.11	-	58.98	48.98	-26.87	-
4	3.594	0.34	30.12	-	30.46	-	56.00	46.00	-25.54	-
5	3.875	0.36	32.93	-	33.29	-	56.00	46.00	-22.71	-
6	4.367	0.38	31.06	-	31.44	-	56.00	46.00	-24.56	-

- REMARKS:**
1. Q.P. and AV. are abbreviations of quasi-peak and average individually.
 2. "-": The Quasi-peak reading value also meets average limit and measurement with the average detector is unnecessary.
 3. The emission levels of other frequencies were very low against the limit.
 4. Margin value = Emission level - Limit value
 5. Correction factor = Insertion loss + Cable loss
 6. Emission Level = Correction Factor + Reading Value.

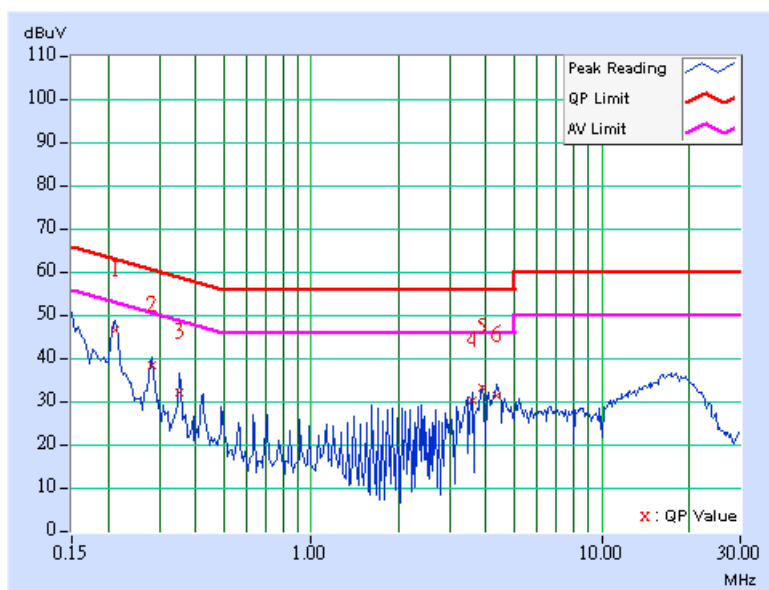

EUT TEST CONDITION		MEASUREMENT DETAIL	
CHANNEL	Channel 11	PHASE	Line 1
MODULATION TYPE	BPSK	6dB BANDWIDTH	9 kHz
TRANSFER RATE	6Mbps	INPUT POWER (SYSTEM)	120Vac, 60 Hz
ENVIRONMENTAL CONDITIONS	20deg. C, 60%RH, 991hPa	TEST MODE	B
TESTED BY	Match Tsui		

No	Freq. [MHz]	Corr. Factor (dB)	Reading Value [dB (uV)]		Emission Level [dB (uV)]		Limit [dB (uV)]		Margin (dB)	
			Q.P.	AV.	Q.P.	AV.	Q.P.	AV.	Q.P.	AV.
			1	0.213	0.10	46.37	-	46.47	-	63.11
2	0.283	0.10	40.85	-	40.95	-	60.73	50.73	-19.78	-
3	0.353	0.10	34.09	-	34.19	-	58.89	48.89	-24.70	-
4	0.423	0.10	34.23	-	34.33	-	57.38	47.38	-23.05	-
5	3.520	0.33	26.41	-	26.74	-	56.00	46.00	-29.26	-
6	3.945	0.37	33.33	-	33.70	-	56.00	46.00	-22.30	-

- REMARKS:**
1. Q.P. and AV. are abbreviations of quasi-peak and average individually.
 2. "-": The Quasi-peak reading value also meets average limit and measurement with the average detector is unnecessary.
 3. The emission levels of other frequencies were very low against the limit.
 4. Margin value = Emission level - Limit value
 5. Correction factor = Insertion loss + Cable loss
 6. Emission Level = Correction Factor + Reading Value.

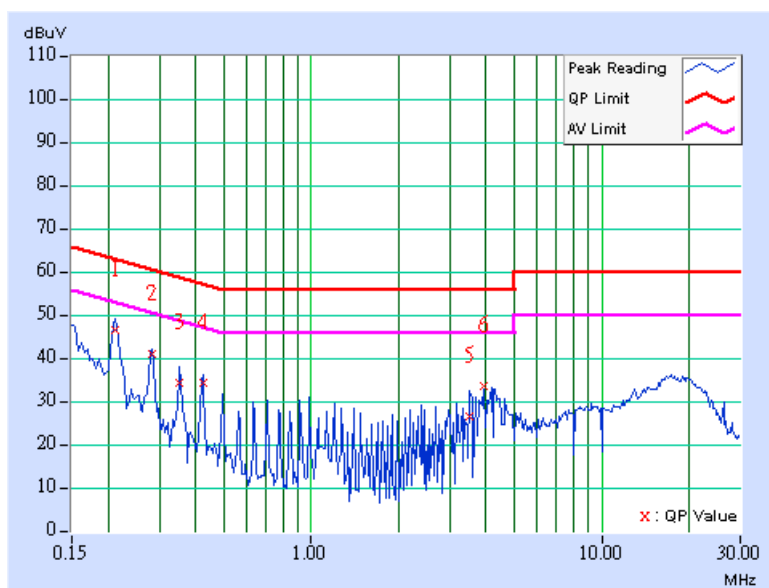

EUT TEST CONDITION		MEASUREMENT DETAIL	
CHANNEL	Channel 11	PHASE	Line 2
MODULATION TYPE	BPSK	6dB BANDWIDTH	9 kHz
TRANSFER RATE	6Mbps	INPUT POWER (SYSTEM)	120Vac, 60 Hz
ENVIRONMENTAL CONDITIONS	20deg. C, 60%RH, 991hPa	TEST MODE	B
TESTED BY	Match Tsui		

No	Freq. [MHz]	Corr. Factor (dB)	Reading Value [dB (uV)]		Emission Level [dB (uV)]		Limit [dB (uV)]		Margin (dB)	
			Q.P.	AV.	Q.P.	AV.	Q.P.	AV.	Q.P.	AV.
	1	0.213	0.10	45.71	-	45.81	-	63.11	53.11	-17.30
2	0.283	0.10	38.36	-	38.46	-	60.73	50.73	-22.27	-
3	0.353	0.10	32.11	-	32.21	-	58.89	48.89	-26.68	-
4	0.423	0.10	29.80	-	29.90	-	57.38	47.38	-27.48	-
5	3.945	0.37	33.60	-	33.97	-	56.00	46.00	-22.03	-
6	4.156	0.37	34.26	-	34.63	-	56.00	46.00	-21.37	-

- REMARKS:**
1. Q.P. and AV. are abbreviations of quasi-peak and average individually.
 2. "-": The Quasi-peak reading value also meets average limit and measurement with the average detector is unnecessary.
 3. The emission levels of other frequencies were very low against the limit.
 4. Margin value = Emission level - Limit value
 5. Correction factor = Insertion loss + Cable loss
 6. Emission Level = Correction Factor + Reading Value.

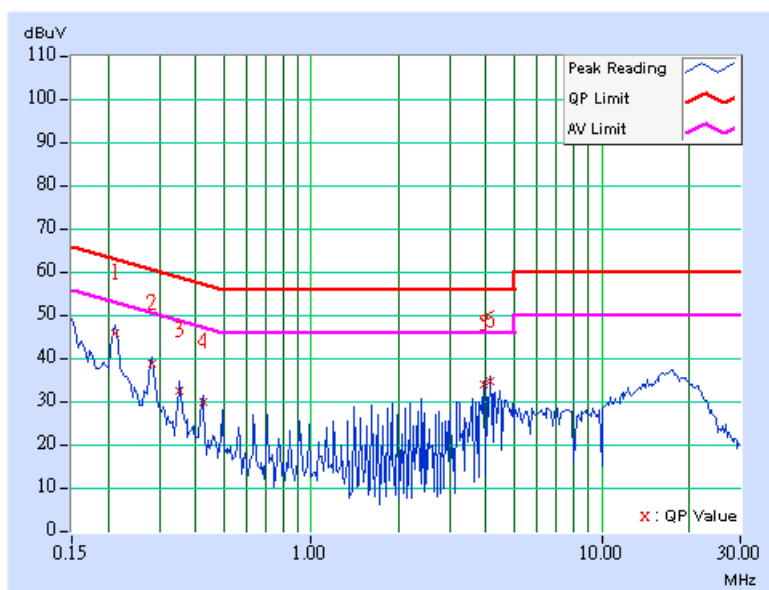

EUT TEST CONDITION		MEASUREMENT DETAIL	
CHANNEL	Channel 1	PHASE	Line 1
MODULATION TYPE	BPSK	6dB BANDWIDTH	9 kHz
TRANSFER RATE	6Mbps	INPUT POWER (SYSTEM)	120Vac, 60 Hz
ENVIRONMENTAL CONDITIONS	20deg. C, 60%RH, 991hPa	TEST MODE	C
TESTED BY	Lori Chiu		

No	Freq. [MHz]	Corr. Factor (dB)	Reading Value [dB (uV)]		Emission Level [dB (uV)]		Limit [dB (uV)]		Margin (dB)	
			Q.P.	AV.	Q.P.	AV.	Q.P.	AV.	Q.P.	AV.
			1	0.220	0.10	40.43	-	40.53	-	62.81
2	0.291	0.10	33.67	-	33.77	-	60.51	50.51	-26.74	-
3	0.435	0.11	30.77	-	30.88	-	57.15	47.15	-26.28	-
4	0.728	0.15	27.90	-	28.05	-	56.00	46.00	-27.95	-
5	0.873	0.18	27.26	-	27.44	-	56.00	46.00	-28.56	-
6	1.820	0.20	27.99	-	28.19	-	56.00	46.00	-27.81	-

- REMARKS:**
1. Q.P. and AV. are abbreviations of quasi-peak and average individually.
 2. "-": The Quasi-peak reading value also meets average limit and measurement with the average detector is unnecessary.
 3. The emission levels of other frequencies were very low against the limit.
 4. Margin value = Emission level - Limit value
 5. Correction factor = Insertion loss + Cable loss
 6. Emission Level = Correction Factor + Reading Value.

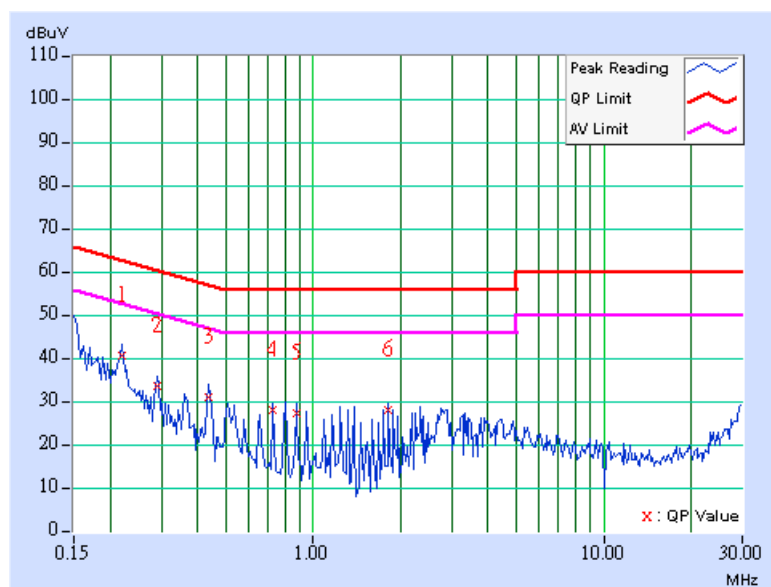

EUT TEST CONDITION		MEASUREMENT DETAIL	
CHANNEL	Channel 1	PHASE	Line 2
MODULATION TYPE	BPSK	6dB BANDWIDTH	9 kHz
TRANSFER RATE	6Mbps	INPUT POWER (SYSTEM)	120Vac, 60 Hz
ENVIRONMENTAL CONDITIONS	20deg. C, 60%RH, 991hPa	TEST MODE	C
TESTED BY	Lori Chiu		

No	Freq. [MHz]	Corr. Factor (dB)	Reading Value [dB (uV)]		Emission Level [dB (uV)]		Limit [dB (uV)]		Margin (dB)	
			Q.P.	AV.	Q.P.	AV.	Q.P.	AV.	Q.P.	AV.
			1	0.216	0.10	40.40	-	40.50	-	62.95
2	0.291	0.10	35.65	-	35.75	-	60.51	50.51	-24.76	-
3	0.435	0.11	31.95	-	32.06	-	57.15	47.15	-25.10	-
4	0.728	0.15	30.18	-	30.33	-	56.00	46.00	-25.67	-
5	1.238	0.20	28.89	-	29.09	-	56.00	46.00	-26.91	-
6	1.746	0.20	28.47	-	28.67	-	56.00	46.00	-27.33	-

- REMARKS:**
1. Q.P. and AV. are abbreviations of quasi-peak and average individually.
 2. "-": The Quasi-peak reading value also meets average limit and measurement with the average detector is unnecessary.
 3. The emission levels of other frequencies were very low against the limit.
 4. Margin value = Emission level - Limit value
 5. Correction factor = Insertion loss + Cable loss
 6. Emission Level = Correction Factor + Reading Value.

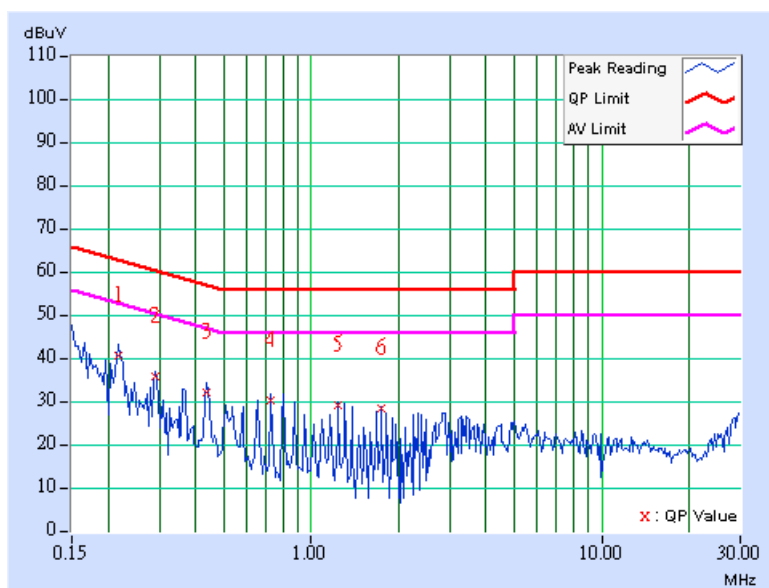

EUT TEST CONDITION		MEASUREMENT DETAIL	
CHANNEL	Channel 6	PHASE	Line 1
MODULATION TYPE	BPSK	6dB BANDWIDTH	9 kHz
TRANSFER RATE	6Mbps	INPUT POWER (SYSTEM)	120Vac, 60 Hz
ENVIRONMENTAL CONDITIONS	20deg. C, 60%RH, 991hPa	TEST MODE	C
TESTED BY	Lori Chiu		

No	Freq. [MHz]	Corr. Factor (dB)	Reading Value		Emission Level		Limit		Margin	
			[dB (uV)]		[dB (uV)]		[dB (uV)]		(dB)	
			Q.P.	AV.	Q.P.	AV.	Q.P.	AV.	Q.P.	AV.
1	0.216	0.10	40.48	-	40.58	-	62.96	52.96	-22.38	-
2	0.291	0.10	33.53	-	33.63	-	60.49	50.49	-26.86	-
3	0.435	0.11	30.87	-	30.98	-	57.15	47.15	-26.18	-
4	0.728	0.15	27.90	-	28.05	-	56.00	46.00	-27.95	-
5	0.873	0.18	27.30	-	27.48	-	56.00	46.00	-28.52	-
6	2.328	0.23	28.06	-	28.29	-	56.00	46.00	-27.71	-

- REMARKS:**
1. Q.P. and AV. are abbreviations of quasi-peak and average individually.
 2. "-": The Quasi-peak reading value also meets average limit and measurement with the average detector is unnecessary.
 3. The emission levels of other frequencies were very low against the limit.
 4. Margin value = Emission level - Limit value
 5. Correction factor = Insertion loss + Cable loss
 6. Emission Level = Correction Factor + Reading Value.

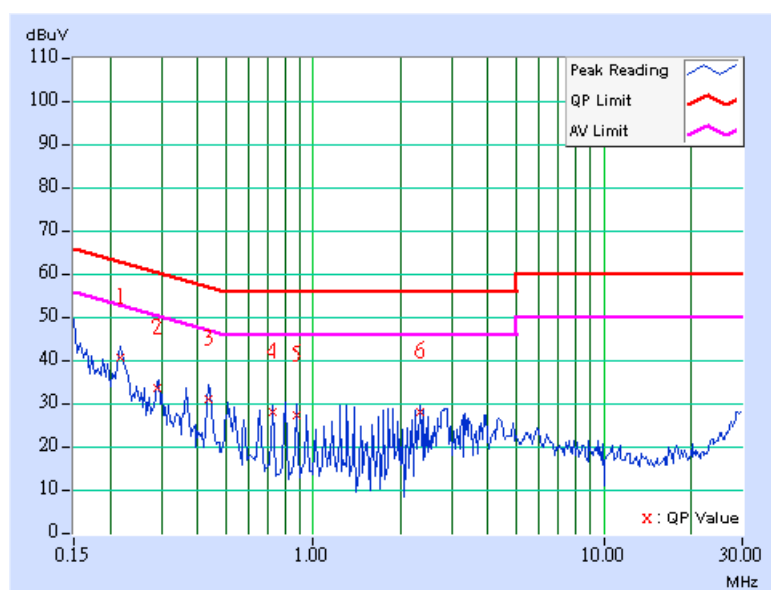

EUT TEST CONDITION		MEASUREMENT DETAIL	
CHANNEL	Channel 6	PHASE	Line 2
MODULATION TYPE	BPSK	6dB BANDWIDTH	9 kHz
TRANSFER RATE	6Mbps	INPUT POWER (SYSTEM)	120Vac, 60 Hz
ENVIRONMENTAL CONDITIONS	20deg. C, 60%RH, 991hPa	TEST MODE	C
TESTED BY	Lori Chiu		

No	Freq. [MHz]	Corr. Factor (dB)	Reading Value [dB (uV)]		Emission Level [dB (uV)]		Limit [dB (uV)]		Margin (dB)	
			Q.P.	AV.	Q.P.	AV.	Q.P.	AV.	Q.P.	AV.
	1	0.220	0.10	39.91	-	40.01	-	62.81	52.81	-22.80
2	0.291	0.10	35.49	-	35.59	-	60.51	50.51	-24.92	-
3	0.437	0.11	32.29	-	32.40	-	57.12	47.12	-24.72	-
4	0.728	0.15	30.20	-	30.35	-	56.00	46.00	-25.65	-
5	1.238	0.20	28.97	-	29.17	-	56.00	46.00	-26.83	-
6	1.820	0.20	28.06	-	28.26	-	56.00	46.00	-27.74	-

- REMARKS:**
1. Q.P. and AV. are abbreviations of quasi-peak and average individually.
 2. "-": The Quasi-peak reading value also meets average limit and measurement with the average detector is unnecessary.
 3. The emission levels of other frequencies were very low against the limit.
 4. Margin value = Emission level - Limit value
 5. Correction factor = Insertion loss + Cable loss
 6. Emission Level = Correction Factor + Reading Value.

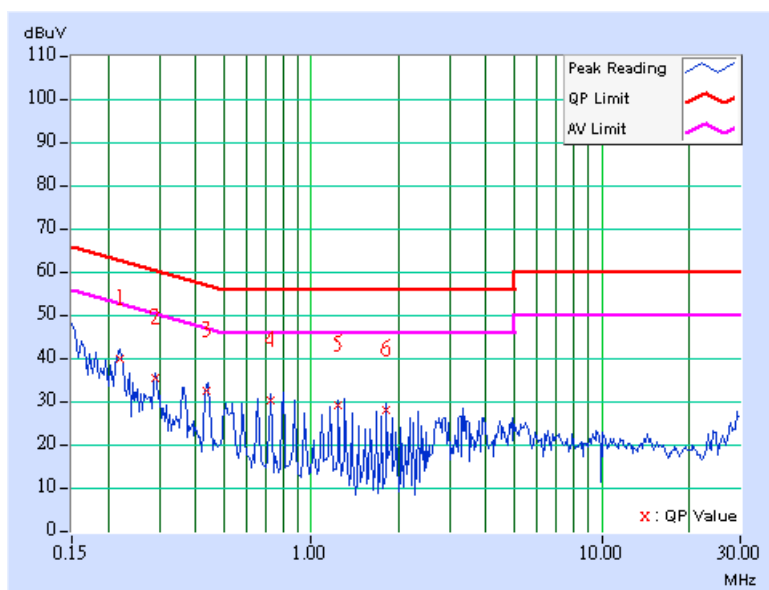

EUT TEST CONDITION		MEASUREMENT DETAIL	
CHANNEL	Channel 11	PHASE	Line 1
MODULATION TYPE	BPSK	6dB BANDWIDTH	9 kHz
TRANSFER RATE	6Mbps	INPUT POWER (SYSTEM)	120Vac, 60 Hz
ENVIRONMENTAL CONDITIONS	20deg. C, 60%RH, 991hPa	TEST MODE	C
TESTED BY	Lori Chiu		

No	Freq. [MHz]	Corr. Factor (dB)	Reading Value [dB (uV)]		Emission Level [dB (uV)]		Limit [dB (uV)]		Margin (dB)	
			Q.P.	AV.	Q.P.	AV.	Q.P.	AV.	Q.P.	AV.
			1	0.220	0.10	39.97	-	40.07	-	62.81
2	0.291	0.10	33.33	-	33.43	-	60.51	50.51	-27.08	-
3	0.435	0.11	30.83	-	30.94	-	57.15	47.15	-26.22	-
4	0.728	0.15	27.98	-	28.13	-	56.00	46.00	-27.87	-
5	0.873	0.18	27.42	-	27.60	-	56.00	46.00	-28.40	-
6	1.820	0.20	27.99	-	28.19	-	56.00	46.00	-27.81	-

- REMARKS:**
1. Q.P. and AV. are abbreviations of quasi-peak and average individually.
 2. "-": The Quasi-peak reading value also meets average limit and measurement with the average detector is unnecessary.
 3. The emission levels of other frequencies were very low against the limit.
 4. Margin value = Emission level - Limit value
 5. Correction factor = Insertion loss + Cable loss
 6. Emission Level = Correction Factor + Reading Value.

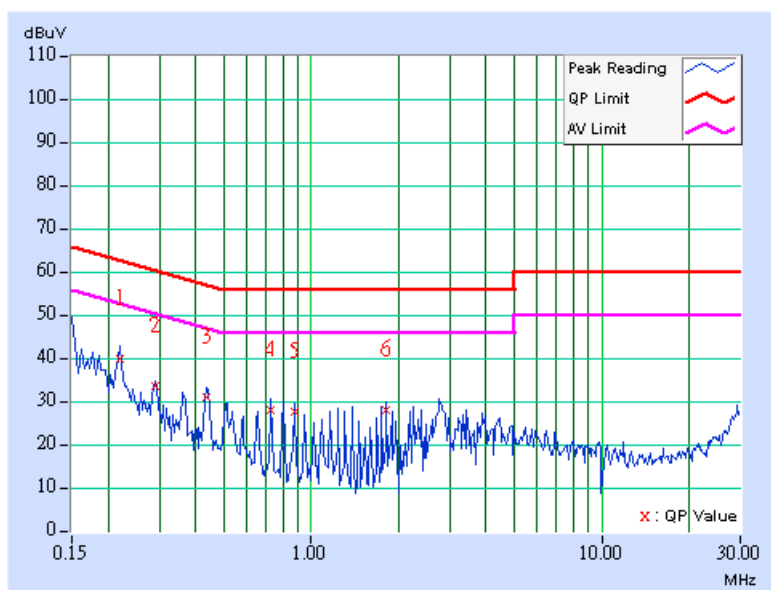

EUT TEST CONDITION		MEASUREMENT DETAIL	
CHANNEL	Channel 11	PHASE	Line 2
MODULATION TYPE	BPSK	6dB BANDWIDTH	9 kHz
TRANSFER RATE	6Mbps	INPUT POWER (SYSTEM)	120Vac, 60 Hz
ENVIRONMENTAL CONDITIONS	20deg. C, 60%RH, 991hPa	TEST MODE	C
TESTED BY	Lori Chiu		

No	Freq. [MHz]	Corr. Factor (dB)	Reading Value [dB (uV)]		Emission Level [dB (uV)]		Limit [dB (uV)]		Margin (dB)	
			Q.P.	AV.	Q.P.	AV.	Q.P.	AV.	Q.P.	AV.
			1	0.220	0.10	39.77	-	39.87	-	62.81
2	0.291	0.10	35.45	-	35.55	-	60.51	50.51	-24.96	-
3	0.438	0.11	31.60	-	31.71	-	57.09	47.09	-25.39	-
4	0.728	0.15	30.24	-	30.39	-	56.00	46.00	-25.61	-
5	1.234	0.20	28.00	-	28.20	-	56.00	46.00	-27.80	-
6	1.746	0.20	28.67	-	28.87	-	56.00	46.00	-27.13	-

- REMARKS:**
1. Q.P. and AV. are abbreviations of quasi-peak and average individually.
 2. "-": The Quasi-peak reading value also meets average limit and measurement with the average detector is unnecessary.
 3. The emission levels of other frequencies were very low against the limit.
 4. Margin value = Emission level - Limit value
 5. Correction factor = Insertion loss + Cable loss
 6. Emission Level = Correction Factor + Reading Value.

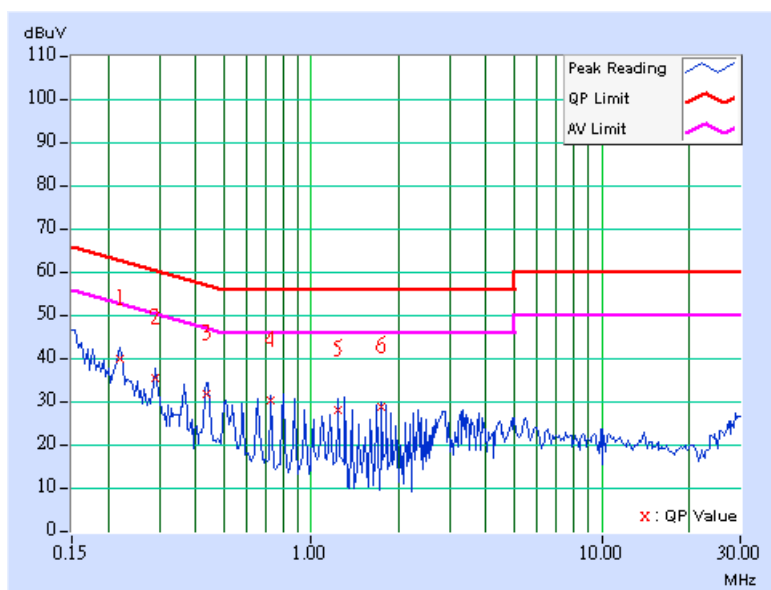



4.2 RADIATED EMISSION MEASUREMENT

4.2.1 LIMITS OF RADIATED EMISSION MEASUREMENT

Emissions radiated outside of the specified bands, shall be according to the general radiated limits in 15.209 as following:

Frequencies (MHz)	Field strength (microvolts/meter)	Measurement distance (meters)
0.009-0.490	2400/F(kHz)	300
0.490-1.705	24000/F(kHz)	30
1.705-30.0	30	30
30-88	100	3
88-216	150	3
216-960	200	3
Above 960	500	3

NOTE:

1. The lower limit shall apply at the transition frequencies.
2. Emission level (dBuV/m) = 20 log Emission level (uV/m).
3. As shown in 15.35(b), for frequencies above 1000MHz, the field strength limits are based on average detector, however, the peak field strength of any emission shall not exceed the maximum permitted average limits, specified above by more than 20dB under any condition of modulation.



4.2.2 TEST INSTRUMENTS

DESCRIPTION & MANUFACTURER	MODEL NO.	SERIAL NO.	CALIBRATED UNTIL
Test Receiver ROHDE & SCHWARZ	ESI7	100033	May. 19, 2006
Spectrum Analyzer ROHDE & SCHWARZ	FSP40	100025	Dec. 05, 2006
BILOG Antenna SCHWARZBECK	VULB9168	9168-160	Jun. 01, 2006
HORN Antenna SCHWARZBECK	9120D	9120D-408	Jan. 08, 2007
HORN Antenna SCHWARZBECK	BBHA 9170	BBHA9170243	Jan. 19, 2007
Preamplifier Agilent	8447D	2944A10633	Nov. 04, 2006
Preamplifier Agilent	8449B	3008A01964	Oct. 30, 2006
RF signal cable HUBER+SUHNNER	SUCOFLEX 104	214377/4	Dec. 13, 2006
RF signal cable HUBER+SUHNNER	SUCOFLEX 104	219272/4	Dec. 13, 2006
Software ADT.	ADT_Radiated_V5.14	NA	NA
Antenna Tower inn-co GmbH	MA 4000	013303	NA
Antenna Tower Controller inn-co GmbH	CO2000	017303	NA
Turn Table ADT.	TT100.	TT93021703	NA
Turn Table Controller ADT.	SC100.	SC93021703	NA

- NOTE:**
1. The calibration interval of the above test instruments is 12 months and the calibrations are traceable to NML/ROC and NIST/USA.
 2. The test was performed in HwaYa Chamber 2.
 3. The horn antenna and HP preamplifier (model: 8449B) are used only for the measurement of emission frequency above 1GHz if tested.
 4. The VCCI Site Registration No. is R-237.
 5. The IC Site Registration No. is IC4924-3.

4.2.3 TEST PROCEDURES

- a. The EUT was placed on the top of a rotating table 0.8 meters above the ground at a 3 meters semi-anechoic chamber. The table was rotated 360 degrees to determine the position of the highest radiation.
- b. The EUT was set 3 meters away from the interference-receiving antenna, which was mounted on the top of a variable-height antenna tower.
- c. The antenna is a broadband antenna, and its height is varied from one meter to four meters above the ground to determine the maximum value of the field strength. Both horizontal and vertical polarizations of the antenna are set to make the measurement.
- d. For each suspected emission, the EUT was arranged to its worst case and then the antenna was tuned to heights from 1 meter to 4 meters and the rotatable table was turned from 0 degrees to 360 degrees to find the maximum reading.
- e. The test-receiver system was set to Peak Detect Function and Specified Bandwidth with Maximum Hold Mode.
- f. If the emission level of the EUT in peak mode was lower than the limit specified, then testing could be stopped and the peak values of the EUT would be reported. Otherwise the emissions would be re-tested one by one using peak, quasi-peak or average method as specified and then reported in a data sheet.

NOTE:

1. The resolution bandwidth and video bandwidth of test receiver/spectrum analyzer is 120kHz for Peak detection (PK) and Quasi-peak detection (QP) at frequency below 1GHz.
2. The resolution bandwidth and video bandwidth of test receiver/spectrum analyzer is 1 MHz for Peak detection at frequency above 1GHz.
3. The resolution bandwidth of test receiver/spectrum analyzer is 1MHz and the video bandwidth is 1kHz for Average detection (AV) at frequency above 1GHz.

4.2.4 DEVIATION FROM TEST STANDARD

No deviation

4.2.5 TEST SETUP

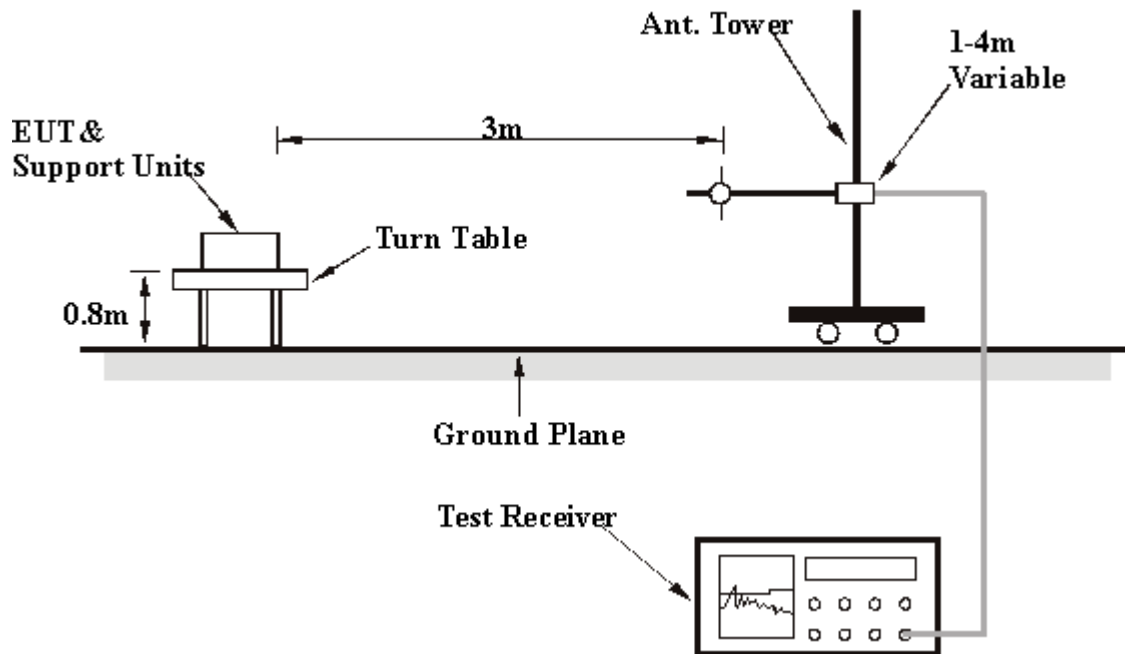

For the actual test configuration, please refer to the related item – Photographs of the Test Configuration.

4.2.6 EUT OPERATING CONDITIONS

Same as 4.1.6



4.2.7 TEST RESULTS

Below 1GHz Worst-Case Data

EUT TEST CONDITION		MEASUREMENT DETAIL	
CHANNEL	Channel 11	FREQUENCY RANGE	Below 1000MHz
MODULATION TYPE	BPSK	DETECTOR FUNCTION	Quasi-Peak
TRANSFER RATE	6Mbps	INPUT POWER (SYSTEM)	120Vac, 60 Hz
ENVIRONMENTAL CONDITIONS	25deg. C, 65%RH, 991hPa	TEST MODE	A
TESTED BY	Jay Hsu		

ANTENNA POLARITY & TEST DISTANCE: HORIZONTAL AT 3 M								
No.	Freq. (MHz)	Emission Level (dBuV/m)	Limit (dBuV/m)	Margin (dB)	Antenna Height (m)	Table Angle (Degree)	Raw Value (dBuV)	Correction Factor (dB/m)
1	39.72	25.92 QP	40.00	-14.08	1.50 H	160	11.51	14.42
2	78.60	26.03 QP	40.00	-13.97	1.00 H	160	15.34	10.69
3	119.42	27.18 QP	43.50	-16.32	1.00 H	157	16.10	11.08
4	366.29	28.56 QP	46.00	-17.44	1.50 H	232	11.35	17.21
5	811.44	30.44 QP	46.00	-15.56	1.50 H	244	3.67	26.78
6	817.27	28.62 QP	46.00	-17.38	1.50 H	100	1.80	26.83
7	863.93	28.03 QP	46.00	-17.97	1.00 H	172	0.77	27.26
8	902.81	28.55 QP	46.00	-17.45	1.00 H	97	0.92	27.62
9	912.53	28.66 QP	46.00	-17.34	1.00 H	100	0.89	27.77

ANTENNA POLARITY & TEST DISTANCE: VERTICAL AT 3 M								
No.	Freq. (MHz)	Emission Level (dBuV/m)	Limit (dBuV/m)	Margin (dB)	Antenna Height (m)	Table Angle (Degree)	Raw Value (dBuV)	Correction Factor (dB/m)
1	39.72	36.50 QP	40.00	-3.50	1.00 V	247	22.08	14.42
2	80.17	34.39 QP	40.00	-5.61	1.00 V	1	23.99	10.40
3	119.42	30.61 QP	43.50	-12.89	1.00 V	187	19.53	11.08
4	142.75	27.37 QP	43.50	-16.13	1.00 V	232	14.02	13.35
5	366.29	28.32 QP	46.00	-17.68	1.50 V	10	11.11	17.21
6	432.38	29.57 QP	46.00	-16.43	1.50 V	10	10.70	18.87
7	498.48	28.95 QP	46.00	-17.05	1.50 V	10	8.52	20.43
8	630.66	28.17 QP	46.00	-17.83	1.50 V	10	4.78	23.40
9	774.51	28.06 QP	46.00	-17.94	1.00 V	229	1.58	26.48
10	811.44	31.32 QP	46.00	-14.68	1.00 V	118	4.54	26.78
11	830.88	29.79 QP	46.00	-16.21	1.00 V	238	2.84	26.95
12	860.04	29.58 QP	46.00	-16.42	1.00 V	232	2.36	27.22
13	879.48	28.38 QP	46.00	-17.62	1.00 V	79	0.98	27.40
14	912.53	30.00 QP	46.00	-16.00	1.50 V	118	2.23	27.77

- REMARKS:**
1. Emission level(dBuV/m)=Raw Value(dBuV) + Correction Factor(dB/m)
 2. Correction Factor(dB/m) = Antenna Factor (dB/m) + Cable Factor (dB)
 3. The other emission levels were very low against the limit.
 4. Margin value = Emission level – Limit value.



EUT TEST CONDITION		MEASUREMENT DETAIL	
CHANNEL	Channel 11	FREQUENCY RANGE	Below 1000MHz
MODULATION TYPE	BPSK	DETECTOR FUNCTION	Quasi-Peak
TRANSFER RATE	6Mbps	INPUT POWER (SYSTEM)	120Vac, 60 Hz
ENVIRONMENTAL CONDITIONS	25deg. C, 65%RH, 991hPa	TEST MODE	B
TESTED BY	Jay Hsu		

ANTENNA POLARITY & TEST DISTANCE: HORIZONTAL AT 3 M								
No.	Freq. (MHz)	Emission Level (dBuV/m)	Limit (dBuV/m)	Margin (dB)	Antenna Height (m)	Table Angle (Degree)	Raw Value (dBuV)	Correction Factor (dB/m)
1	39.72	24.90 QP	40.00	-15.10	1.00 H	97	10.49	14.42
2	78.60	27.04 QP	40.00	-12.96	1.00 H	127	16.35	10.69
3	119.42	28.95 QP	43.50	-14.55	1.00 H	37	17.88	11.08
4	158.30	31.99 QP	43.50	-11.51	1.00 H	238	18.22	13.76
5	177.74	27.21 QP	43.50	-16.29	1.00 H	127	14.88	12.34
6	220.50	29.97 QP	46.00	-16.03	1.00 H	232	18.18	11.79
7	366.29	32.76 QP	46.00	-13.24	1.00 H	115	15.55	17.21
8	745.35	28.85 QP	46.00	-17.15	1.00 H	37	2.74	26.10
9	811.44	30.63 QP	46.00	-15.37	1.00 H	175	3.86	26.78
10	830.88	29.68 QP	46.00	-16.32	1.00 H	127	2.73	26.95
11	912.53	28.70 QP	46.00	-17.30	1.00 H	238	0.93	27.77

ANTENNA POLARITY & TEST DISTANCE: VERTICAL AT 3 M								
No.	Freq. (MHz)	Emission Level (dBuV/m)	Limit (dBuV/m)	Margin (dB)	Antenna Height (m)	Table Angle (Degree)	Raw Value (dBuV)	Correction Factor (dB/m)
1	39.72	34.08 QP	40.00	-5.92	1.00 V	58	19.67	14.42
2	78.60	36.51 QP	40.00	-3.49	1.00 V	91	25.82	10.69
3	99.98	33.64 QP	43.50	-9.86	1.00 V	28	24.29	9.35
4	138.86	30.01 QP	43.50	-13.49	1.00 V	58	16.85	13.16
5	366.29	29.63 QP	46.00	-16.37	1.50 V	97	12.42	17.21
6	432.38	28.88 QP	46.00	-17.12	1.50 V	97	10.01	18.87
7	630.66	29.04 QP	46.00	-16.96	1.50 V	97	5.65	23.40
8	811.44	28.98 QP	46.00	-17.02	1.00 V	61	2.21	26.78
9	830.88	29.35 QP	46.00	-16.65	1.00 V	91	2.40	26.95
10	860.04	28.47 QP	46.00	-17.53	1.00 V	22	1.25	27.22
11	918.36	28.59 QP	46.00	-17.41	1.00 V	58	0.73	27.86

- REMARKS:**
1. Emission level(dBuV/m)=Raw Value(dBuV) + Correction Factor(dB/m)
 2. Correction Factor(dB/m) = Antenna Factor (dB/m) + Cable Factor (dB)
 3. The other emission levels were very low against the limit.
 4. Margin value = Emission level – Limit value.



EUT TEST CONDITION		MEASUREMENT DETAIL	
CHANNEL	Channel 11	FREQUENCY RANGE	Below 1000MHz
MODULATION TYPE	BPSK	DETECTOR FUNCTION	Quasi-Peak
TRANSFER RATE	6Mbps	INPUT POWER (SYSTEM)	120Vac, 60 Hz
ENVIRONMENTAL CONDITIONS	25deg. C, 65%RH, 991hPa	TEST MODE	C
TESTED BY	Jay Hsu		

ANTENNA POLARITY & TEST DISTANCE: HORIZONTAL AT 3 M								
No.	Freq. (MHz)	Emission Level (dBuV/m)	Limit (dBuV/m)	Margin (dB)	Antenna Height (m)	Table Angle (Degree)	Raw Value (dBuV)	Correction Factor (dB/m)
1	39.72	30.32 QP	40.00	-9.68	1.50 H	106	15.90	14.42
2	78.60	27.69 QP	40.00	-12.31	1.00 H	76	17.00	10.69
3	119.42	30.76 QP	43.50	-12.74	1.50 H	148	19.68	11.08
4	154.41	31.78 QP	43.50	-11.72	1.50 H	163	18.12	13.66
5	162.18	30.65 QP	43.50	-12.85	1.00 H	115	17.02	13.63
6	212.73	28.99 QP	43.50	-14.51	1.50 H	106	17.44	11.55
7	811.44	30.05 QP	46.00	-15.95	1.00 H	124	3.27	26.78
8	817.27	28.98 QP	46.00	-17.02	1.00 H	358	2.15	26.83
9	860.04	28.50 QP	46.00	-17.50	1.50 H	289	1.28	27.22
10	900.86	28.19 QP	46.00	-17.81	1.50 H	148	0.60	27.59
11	933.91	28.34 QP	46.00	-17.66	1.50 H	163	0.24	28.10

ANTENNA POLARITY & TEST DISTANCE: VERTICAL AT 3 M								
No.	Freq. (MHz)	Emission Level (dBuV/m)	Limit (dBuV/m)	Margin (dB)	Antenna Height (m)	Table Angle (Degree)	Raw Value (dBuV)	Correction Factor (dB/m)
1	40.00	33.17 QP	40.00	-6.83	1.00 V	96	18.68	14.49
2	78.60	31.42 QP	40.00	-8.58	1.00 V	217	20.73	10.69
3	119.42	33.06 QP	43.50	-10.44	1.00 V	343	21.98	11.08
4	148.58	35.52 QP	43.50	-7.98	1.00 V	211	22.01	13.51
5	214.67	31.84 QP	43.50	-11.66	1.00 V	211	20.23	11.61
6	430.44	28.12 QP	46.00	-17.88	1.00 V	226	9.28	18.84
7	486.81	28.63 QP	46.00	-17.37	1.00 V	31	8.50	20.13
8	500.42	28.77 QP	46.00	-17.23	1.00 V	157	8.30	20.48
9	566.51	29.96 QP	46.00	-16.04	1.00 V	157	8.01	21.95
10	630.66	28.41 QP	46.00	-17.59	1.00 V	241	5.02	23.40
11	860.04	28.90 QP	46.00	-17.10	1.00 V	226	1.68	27.22

- REMARKS:**
1. Emission level(dBuV/m)=Raw Value(dBuV) + Correction Factor(dB/m)
 2. Correction Factor(dB/m) = Antenna Factor (dB/m) + Cable Factor (dB)
 3. The other emission levels were very low against the limit.
 4. Margin value = Emission level – Limit value.



802.11b DSSS modulation

EUT TEST CONDITION		MEASUREMENT DETAIL	
CHANNEL	Channel 1	FREQUENCY RANGE	1 ~ 25GHz
MODULATION TYPE	DBPSK	DETECTOR FUNCTION	Peak(PK) Average (AV)
TRANSFER RATE	1Mbps	ENVIRONMENTAL CONDITIONS	23deg. C, 57%RH, 991hPa
INPUT POWER (SYSTEM)	120Vac, 60 Hz	TEST MODE	A
TESTED BY	Jay Hsu		

ANTENNA POLARITY & TEST DISTANCE: HORIZONTAL AT 3 M								
No.	Freq. (MHz)	Emission Level (dBuV/m)	Limit (dBuV/m)	Margin (dB)	Antenna Height (m)	Table Angle (Degree)	Raw Value (dBuV)	Correction Factor (dB/m)
1	2390.00	53.78 PK	74.00	-20.22	1.31 H	64	21.87	31.91
1	2390.00	44.49 AV	54.00	-9.51	1.31 H	64	12.58	31.91
2	*2412.00	97.96 PK			1.31 H	64	65.92	32.04
2	*2412.00	94.49 AV			1.31 H	64	62.45	32.04
3	4824.00	53.88 PK	74.00	-20.12	1.06 H	100	16.37	37.51
3	4824.00	50.17 AV	54.00	-3.83	1.06 H	100	12.66	37.51
4	7236.00	55.37 PK	74.00	-18.63	1.29 H	96	11.44	43.92
4	7236.00	46.52 AV	54.00	-7.48	1.29 H	96	2.59	43.92

ANTENNA POLARITY & TEST DISTANCE: VERTICAL AT 3 M								
No.	Freq. (MHz)	Emission Level (dBuV/m)	Limit (dBuV/m)	Margin (dB)	Antenna Height (m)	Table Angle (Degree)	Raw Value (dBuV)	Correction Factor (dB/m)
1	2390.00	53.14 PK	74.00	-20.86	1.17 V	65	21.23	31.91
1	2390.00	44.51 AV	54.00	-9.49	1.17 V	65	12.60	31.91
2	*2412.00	98.27 PK			1.17 V	65	66.23	32.04
2	*2412.00	94.57 AV			1.17 V	65	62.53	32.04
3	4824.00	51.57 PK	74.00	-22.43	1.55 V	26	14.06	37.51
3	4824.00	46.45 AV	54.00	-7.55	1.55 V	26	8.94	37.51
4	7236.00	53.41 PK	74.00	-20.59	1.24 V	63	9.49	43.92
4	7236.00	44.83 AV	54.00	-9.17	1.24 V	63	0.91	43.92

- REMARKS:**
1. Emission level(dBuV/m)=Raw Value(dBuV) + Correction Factor(dB/m)
 2. Correction Factor(dB/m) = Antenna Factor (dB/m) + Cable Factor (dB)
 3. The other emission levels were very low against the limit.
 4. Margin value = Emission level – Limit value.
 5. The limit value is defined as per 15.247
 6. " * " : Fundamental frequency



EUT TEST CONDITION		MEASUREMENT DETAIL	
CHANNEL	Channel 6	FREQUENCY RANGE	1 ~ 25GHz
MODULATION TYPE	DBPSK	DETECTOR FUNCTION	Peak(PK) Average (AV)
TRANSFER RATE	1Mbps	ENVIRONMENTAL CONDITIONS	23deg. C, 57%RH, 991hPa
INPUT POWER (SYSTEM)	120Vac, 60 Hz	TEST MODE	A
TESTED BY	Jay Hsu		

ANTENNA POLARITY & TEST DISTANCE: HORIZONTAL AT 3 M								
No.	Freq. (MHz)	Emission Level (dBuV/m)	Limit (dBuV/m)	Margin (dB)	Antenna Height (m)	Table Angle (Degree)	Raw Value (dBuV)	Correction Factor (dB/m)
1	*2437.00	98.57 PK			1.34 H	75	66.37	32.20
1	*2437.00	95.01 AV			1.34 H	75	62.81	32.20
2	4874.00	54.62 PK	74.00	-19.38	1.20 H	100	17.07	37.55
2	4874.00	51.18 AV	54.00	-2.82	1.20 H	100	13.63	37.55
3	7386.00	56.23 PK	74.00	-17.77	1.29 H	85	12.25	43.98
3	7386.00	48.12 AV	54.00	-5.88	1.29 H	85	4.14	43.98

ANTENNA POLARITY & TEST DISTANCE: VERTICAL AT 3 M								
No.	Freq. (MHz)	Emission Level (dBuV/m)	Limit (dBuV/m)	Margin (dB)	Antenna Height (m)	Table Angle (Degree)	Raw Value (dBuV)	Correction Factor (dB/m)
1	*2437.00	99.27 PK			1.15 V	63	67.07	32.20
1	*2437.00	95.26 AV			1.15 V	63	63.06	32.20
2	4874.00	51.68 PK	74.00	-22.32	1.24 V	24	14.13	37.55
2	4874.00	47.15 AV	54.00	-6.85	1.24 V	24	9.60	37.55
3	7311.00	53.56 PK	74.00	-20.44	1.30 V	67	9.53	44.03
3	7311.00	44.95 AV	54.00	-9.05	1.30 V	67	0.92	44.03

- REMARKS:**
1. Emission level(dBuV/m)=Raw Value(dBuV) + Correction Factor(dB/m)
 2. Correction Factor(dB/m) = Antenna Factor (dB/m) + Cable Factor (dB)
 3. The other emission levels were very low against the limit.
 4. Margin value = Emission level – Limit value.
 5. The limit value is defined as per 15.247
 6. “ * “ : Fundamental frequency



EUT TEST CONDITION		MEASUREMENT DETAIL	
CHANNEL	Channel 11	FREQUENCY RANGE	1 ~ 25GHz
MODULATION TYPE	DBPSK	DETECTOR FUNCTION	Peak(PK) Average (AV)
TRANSFER RATE	1Mbps	ENVIRONMENTAL CONDITIONS	23deg. C, 57%RH, 991hPa
INPUT POWER (SYSTEM)	120Vac, 60 Hz	TEST MODE	A
TESTED BY	Jay Hsu		

ANTENNA POLARITY & TEST DISTANCE: HORIZONTAL AT 3 M								
No.	Freq. (MHz)	Emission Level (dBuV/m)	Limit (dBuV/m)	Margin (dB)	Antenna Height (m)	Table Angle (Degree)	Raw Value (dBuV)	Correction Factor (dB/m)
1	*2462.00	98.02 PK			1.30 H	67	65.67	32.35
1	*2462.00	94.57 AV			1.30 H	67	62.22	32.35
2	2483.50	53.87 PK	74.00	-20.13	1.30 H	74	21.38	32.49
2	2483.50	44.68 AV	54.00	-9.32	1.30 H	74	12.19	32.49
3	4924.00	54.12 PK	74.00	-19.88	1.10 H	102	16.54	37.58
3	4924.00	50.67 AV	54.00	-3.33	1.10 H	102	13.09	37.58
4	7386.00	55.87 PK	74.00	-18.13	1.31 H	78	11.89	43.98
4	7386.00	47.89 AV	54.00	-6.11	1.31 H	78	3.91	43.98

ANTENNA POLARITY & TEST DISTANCE: VERTICAL AT 3 M								
No.	Freq. (MHz)	Emission Level (dBuV/m)	Limit (dBuV/m)	Margin (dB)	Antenna Height (m)	Table Angle (Degree)	Raw Value (dBuV)	Correction Factor (dB/m)
1	*2462.00	98.75 PK			1.20 V	73	66.40	32.35
1	*2462.00	95.03 AV			1.20 V	73	62.68	32.35
2	2483.50	53.67 PK	74.00	-20.33	1.20 V	73	21.18	32.49
2	2483.50	45.13 AV	54.00	-8.87	1.20 V	73	12.64	32.49
3	4924.00	52.12 PK	74.00	-21.88	1.57 V	62	14.54	37.58
3	4924.00	46.58 AV	54.00	-7.42	1.57 V	62	9.00	37.58
4	7386.00	53.87 PK	74.00	-20.13	1.26 V	64	9.89	43.98
4	7386.00	45.52 AV	54.00	-8.48	1.26 V	64	1.54	43.98

- REMARKS:**
1. Emission level(dBuV/m)=Raw Value(dBuV) + Correction Factor(dB/m)
 2. Correction Factor(dB/m) = Antenna Factor (dB/m) + Cable Factor (dB)
 3. The other emission levels were very low against the limit.
 4. Margin value = Emission level – Limit value.
 5. The limit value is defined as per 15.247
 6. “ * “ : Fundamental frequency



802.11g OFDM modulation

EUT TEST CONDITION		MEASUREMENT DETAIL	
CHANNEL	Channel 1	FREQUENCY RANGE	1 ~ 25GHz
MODULATION TYPE	BPSK	DETECTOR FUNCTION	Peak(PK) Average (AV)
TRANSFER RATE	6Mbps	ENVIRONMENTAL CONDITIONS	23deg. C, 57%RH, 991hPa
INPUT POWER (SYSTEM)	120Vac, 60 Hz	TEST MODE	A
TESTED BY	Jay Hsu		

ANTENNA POLARITY & TEST DISTANCE: HORIZONTAL AT 3 M								
No.	Freq. (MHz)	Emission Level (dBuV/m)	Limit (dBuV/m)	Margin (dB)	Antenna Height (m)	Table Angle (Degree)	Raw Value (dBuV)	Correction Factor (dB/m)
1	2390.00	56.86 PK	74.00	-17.14	1.30 H	63	24.95	31.91
1	2390.00	46.34 AV	54.00	-7.66	1.30 H	63	14.43	31.91
2	*2412.00	98.89 PK			1.30 H	63	66.85	32.04
2	*2412.00	88.91 AV			1.30 H	63	56.87	32.04
3	4824.00	50.62 PK	74.00	-23.38	1.33 H	104	13.11	37.51
3	4824.00	38.44 AV	54.00	-15.56	1.33 H	104	0.93	37.51
4	7236.00	69.72 PK	74.00	-4.28	1.29 H	93	25.79	43.92
4	7236.00	50.87 AV	54.00	-3.13	1.29 H	93	6.94	43.92

ANTENNA POLARITY & TEST DISTANCE: VERTICAL AT 3 M								
No.	Freq. (MHz)	Emission Level (dBuV/m)	Limit (dBuV/m)	Margin (dB)	Antenna Height (m)	Table Angle (Degree)	Raw Value (dBuV)	Correction Factor (dB/m)
1	2390.00	58.39 PK	74.00	-15.61	1.13 V	101	26.48	31.91
1	2390.00	45.88 AV	54.00	-8.12	1.13 V	101	13.97	31.91
2	*2412.00	99.54 PK			1.13 V	101	67.50	32.04
2	*2412.00	90.15 AV			1.13 V	101	58.11	32.04
3	4824.00	47.78 PK	74.00	-26.22	1.10 V	130	10.27	37.51
3	4824.00	36.54 AV	54.00	-17.46	1.10 V	130	-0.97	37.51
4	7236.00	66.13 PK	74.00	-7.87	1.11 V	126	22.21	43.92
4	7236.00	47.11 AV	54.00	-6.89	1.11 V	126	3.19	43.92

- REMARKS:**
1. Emission level(dBuV/m)=Raw Value(dBuV) + Correction Factor(dB/m)
 2. Correction Factor(dB/m) = Antenna Factor (dB/m) + Cable Factor (dB)
 3. The other emission levels were very low against the limit.
 4. Margin value = Emission level – Limit value.
 5. The limit value is defined as per 15.247
 6. “ * “ : Fundamental frequency



EUT TEST CONDITION		MEASUREMENT DETAIL	
CHANNEL	Channel 6	FREQUENCY RANGE	1 ~ 25GHz
MODULATION TYPE	BPSK	DETECTOR FUNCTION	Peak(PK) Average (AV)
TRANSFER RATE	6Mbps	ENVIRONMENTAL CONDITIONS	23deg. C, 57%RH, 991hPa
INPUT POWER (SYSTEM)	120Vac, 60 Hz	TEST MODE	A
TESTED BY	Jay Hsu		

ANTENNA POLARITY & TEST DISTANCE: HORIZONTAL AT 3 M								
No.	Freq. (MHz)	Emission Level (dBuV/m)	Limit (dBuV/m)	Margin (dB)	Antenna Height (m)	Table Angle (Degree)	Raw Value (dBuV)	Correction Factor (dB/m)
1	*2437.00	98.51 PK			1.33 H	67	66.31	32.20
1	*2437.00	88.76 AV			1.33 H	67	56.56	32.20
2	4874.00	48.64 PK	74.00	-25.36	1.45 H	64	11.09	37.55
2	4874.00	36.48 AV	54.00	-17.52	1.45 H	64	-1.07	37.55
3	7311.00	70.17 PK	74.00	-3.83	1.47 H	96	26.14	44.03
3	7311.00	48.57 AV	54.00	-5.43	1.47 H	96	4.54	44.03

ANTENNA POLARITY & TEST DISTANCE: VERTICAL AT 3 M								
No.	Freq. (MHz)	Emission Level (dBuV/m)	Limit (dBuV/m)	Margin (dB)	Antenna Height (m)	Table Angle (Degree)	Raw Value (dBuV)	Correction Factor (dB/m)
1	*2437.00	99.69 PK			1.15 V	67	67.49	32.20
1	*2437.00	90.65 AV			1.15 V	67	58.45	32.20
2	4874.00	48.41 PK	74.00	-25.59	1.10 V	128	10.86	37.55
2	4874.00	36.80 AV	54.00	-17.20	1.10 V	128	-0.75	37.55
3	7311.00	62.49 PK	74.00	-11.51	1.10 V	124	18.46	44.03
3	7311.00	44.01 AV	54.00	-9.99	1.10 V	124	-0.02	44.03

- REMARKS:**
1. Emission level(dBuV/m)=Raw Value(dBuV) + Correction Factor(dB/m)
 2. Correction Factor(dB/m) = Antenna Factor (dB/m) + Cable Factor (dB)
 3. The other emission levels were very low against the limit.
 4. Margin value = Emission level – Limit value.
 5. The limit value is defined as per 15.247
 6. “ * “ : Fundamental frequency



EUT TEST CONDITION		MEASUREMENT DETAIL	
CHANNEL	Channel 11	FREQUENCY RANGE	1 ~ 25GHz
MODULATION TYPE	BPSK	DETECTOR FUNCTION	Peak(PK) Average (AV)
TRANSFER RATE	6Mbps	ENVIRONMENTAL CONDITIONS	23deg. C, 57%RH, 991hPa
INPUT POWER (SYSTEM)	120Vac, 60 Hz	TEST MODE	A
TESTED BY	Jay Hsu		

ANTENNA POLARITY & TEST DISTANCE: HORIZONTAL AT 3 M								
No.	Freq. (MHz)	Emission Level (dBuV/m)	Limit (dBuV/m)	Margin (dB)	Antenna Height (m)	Table Angle (Degree)	Raw Value (dBuV)	Correction Factor (dB/m)
1	*2462.00	98.56 PK			1.30 H	68	66.21	32.35
1	*2462.00	88.65 AV			1.30 H	68	56.30	32.35
2	2483.50	61.25 PK	74.00	-12.75	1.30 H	68	28.76	32.49
2	2483.50	46.36 AV	54.00	-7.64	1.30 H	68	13.87	32.49
3	4924.00	47.52 PK	74.00	-26.48	1.47 H	61	9.94	37.58
3	4924.00	36.81 AV	54.00	-17.19	1.47 H	61	-0.77	37.58
4	7386.00	71.14 PK	74.00	-2.86	1.27 H	97	27.16	43.98
4	7386.00	51.73 AV	54.00	-2.27	1.27 H	97	7.75	43.98

ANTENNA POLARITY & TEST DISTANCE: VERTICAL AT 3 M								
No.	Freq. (MHz)	Emission Level (dBuV/m)	Limit (dBuV/m)	Margin (dB)	Antenna Height (m)	Table Angle (Degree)	Raw Value (dBuV)	Correction Factor (dB/m)
1	*2462.00	99.89 PK			1.08 V	109	67.54	32.35
1	*2462.00	91.41 AV			1.08 V	109	59.06	32.35
2	2483.50	57.66 PK	74.00	-16.34	1.08 V	109	25.17	32.49
2	2483.50	46.53 AV	54.00	-7.47	1.08 V	109	14.04	32.49
3	4924.00	47.06 PK	74.00	-26.94	1.11 V	135	9.48	37.58
3	4924.00	36.15 AV	54.00	-17.85	1.11 V	135	-1.43	37.58
4	7386.00	65.32 PK	74.00	-8.68	1.16 V	124	21.34	43.98
4	7386.00	46.20 AV	54.00	-7.80	1.16 V	124	2.22	43.98

- REMARKS:**
1. Emission level(dBuV/m)=Raw Value(dBuV) + Correction Factor(dB/m)
 2. Correction Factor(dB/m) = Antenna Factor (dB/m) + Cable Factor (dB)
 3. The other emission levels were very low against the limit.
 4. Margin value = Emission level – Limit value.
 5. The limit value is defined as per 15.247
 6. “ * “ : Fundamental frequency



4.3 6dB BANDWIDTH MEASUREMENT

4.3.1 LIMITS OF 6dB BANDWIDTH MEASUREMENT

The minimum of 6dB Bandwidth Measurement is 0.5 MHz.

4.3.2 TEST INSTRUMENTS

Description & Manufacturer	Model No.	Serial No.	Calibrated Until
SPECTRUM ANALYZER	FSEK 30	100049	Aug. 14, 2006

NOTE: The calibration interval of the above test instruments is 12 months and the calibrations are traceable to NML/ROC and NIST/USA.

4.3.3 TEST PROCEDURE

The transmitter output was connected to the spectrum analyzer through an attenuator. The bandwidth of the fundamental frequency was measured by spectrum analyzer with 100kHz RBW and 100kHz VBW. The 6dB bandwidth is defined as the total spectrum the power of which is higher than peak power minus 6dB.

4.3.4 DEVIATION FROM TEST STANDARD

No deviation

4.3.5 TEST SETUP

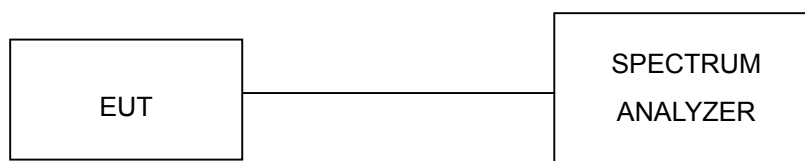

4.3.6 EUT OPERATING CONDITIONS

The software provided by client to enable the EUT under transmission condition continuously at lowest, middle and highest channel frequencies individually.



4.3.7 TEST RESULTS

802.11b DSSS modulation

MODULATION TYPE	DBPSK	TRANSFER RATE	1Mbps
INPUT POWER (SYSTEM)	120Vac, 60 Hz	ENVIRONMENTAL CONDITIONS	26deg.C, 66%RH, 991hPa
TESTED BY	Morgan Chen		

CHANNEL	CHANNEL FREQUENCY (MHz)	6dB BANDWIDTH (MHz)	MINIMUM LIMIT (MHz)	PASS/FAIL
1	2412	10.08	0.5	PASS
6	2437	9.96	0.5	PASS
11	2462	9.56	0.5	PASS

CH 1

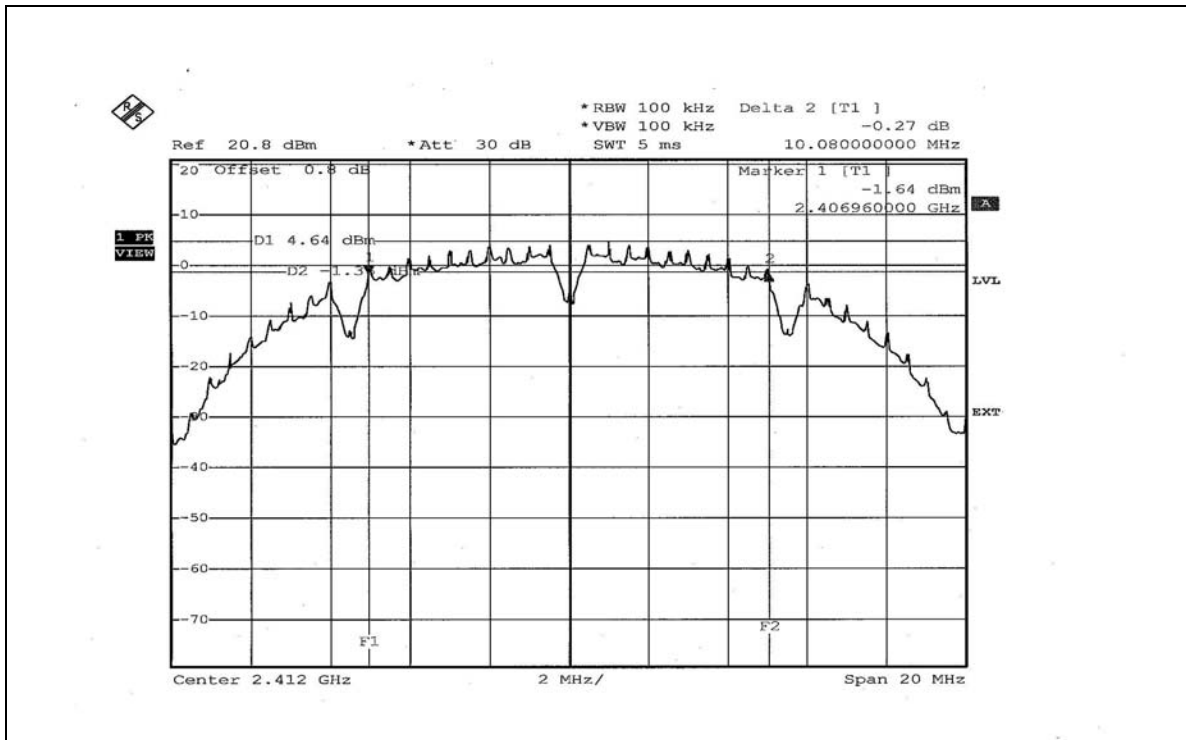

CH 6

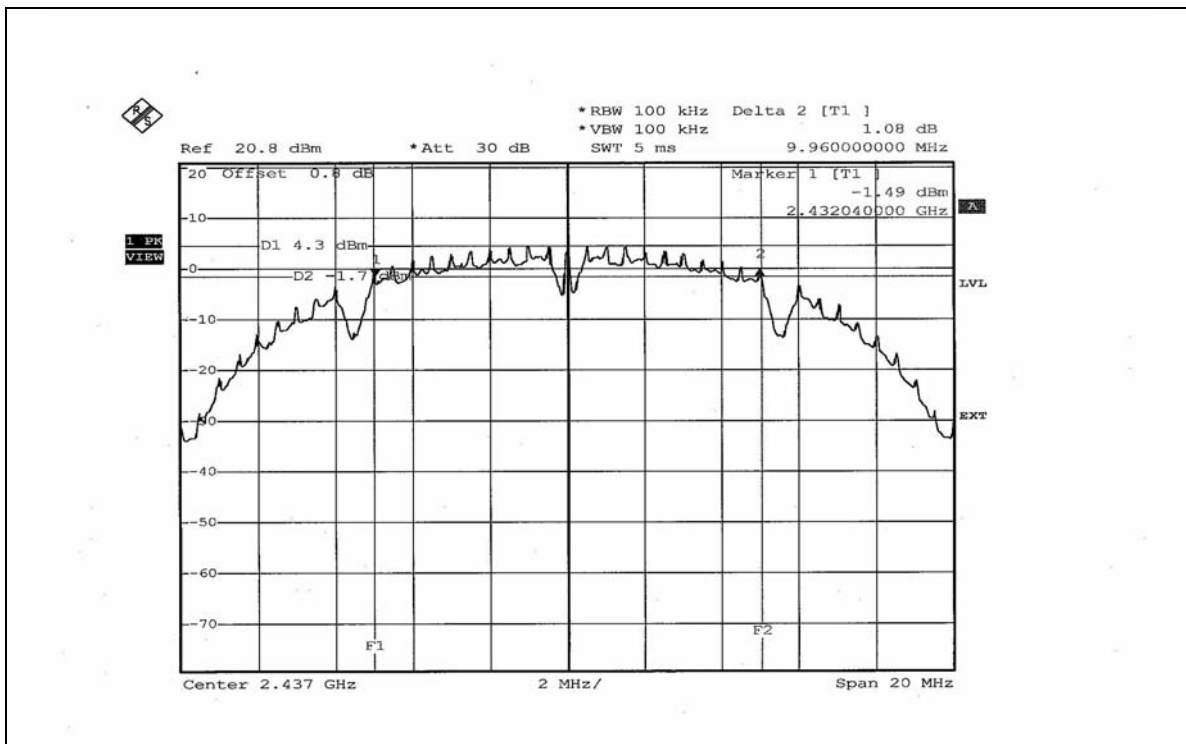

CH 11

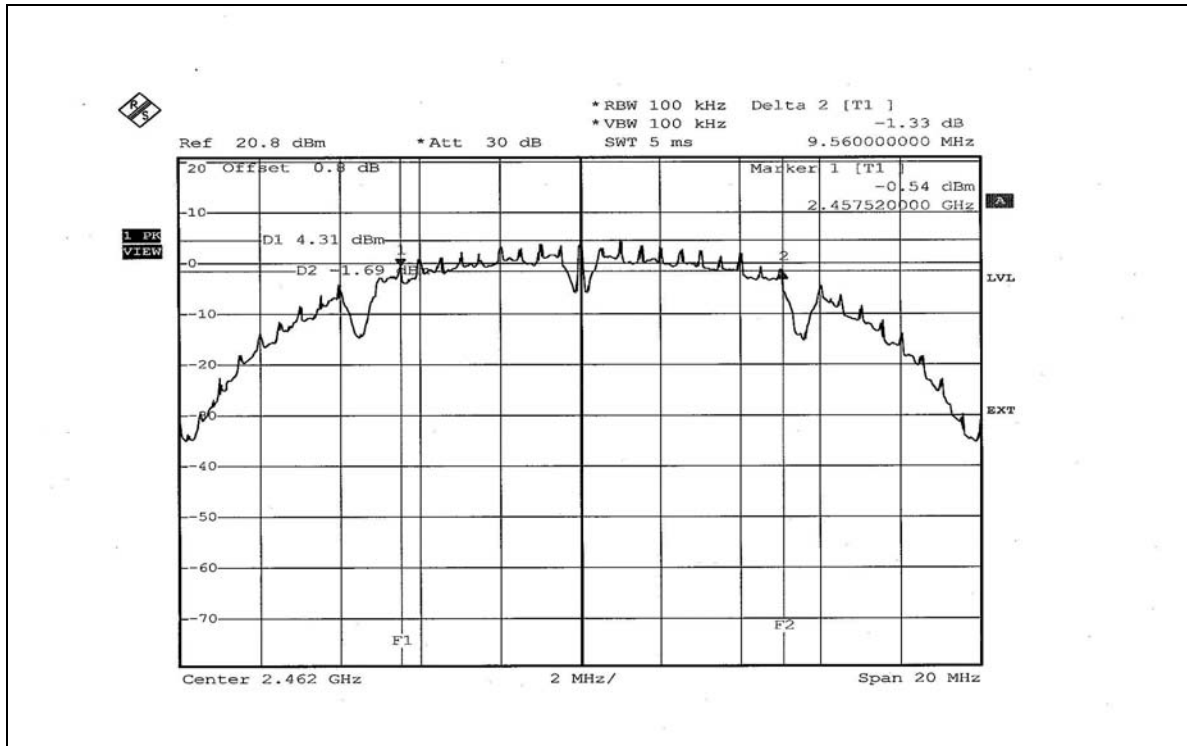



802.11g OFDM modulation

MODULATION TYPE	BPSK	TRANSFER RATE	6Mbps
INPUT POWER (SYSTEM)	120Vac, 60 Hz	ENVIRONMENTAL CONDITIONS	26deg.C, 66%RH, 991hPa
TESTED BY	Morgan Chen		

CHANNEL	CHANNEL FREQUENCY (MHz)	6dB BANDWIDTH (MHz)	MINIMUM LIMIT (MHz)	PASS/FAIL
1	2412	15.12	0.5	PASS
6	2437	16.28	0.5	PASS
11	2462	16.28	0.5	PASS

CH 1

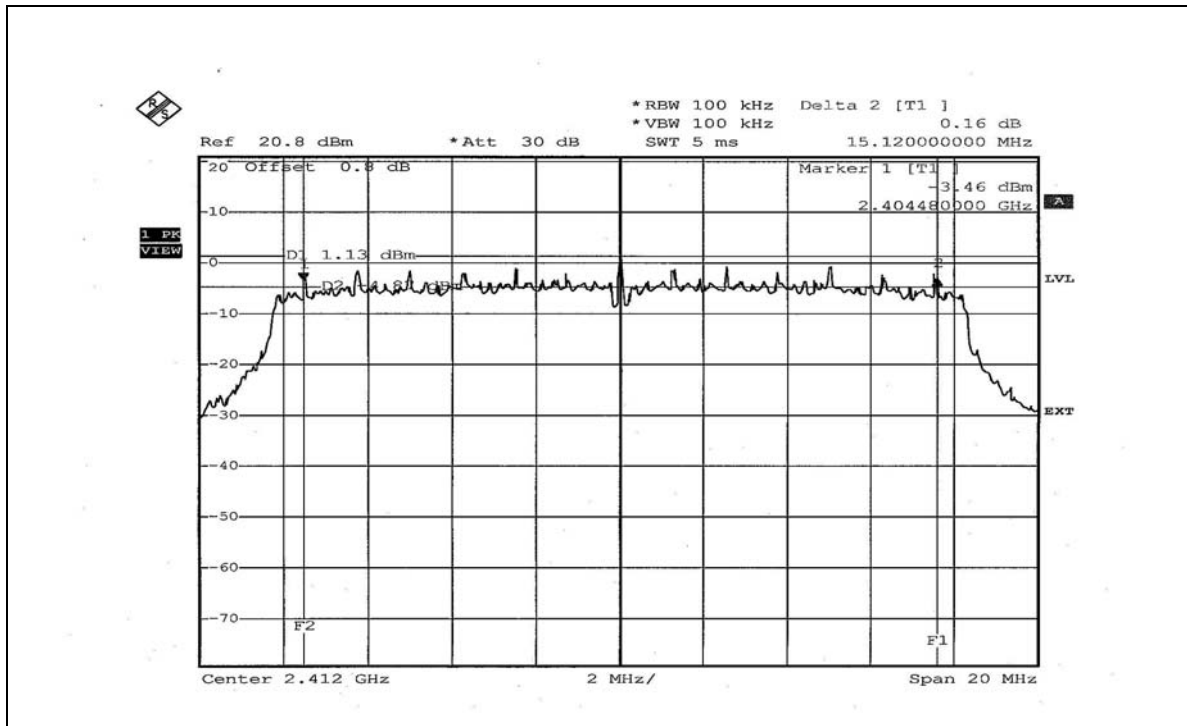

CH 6

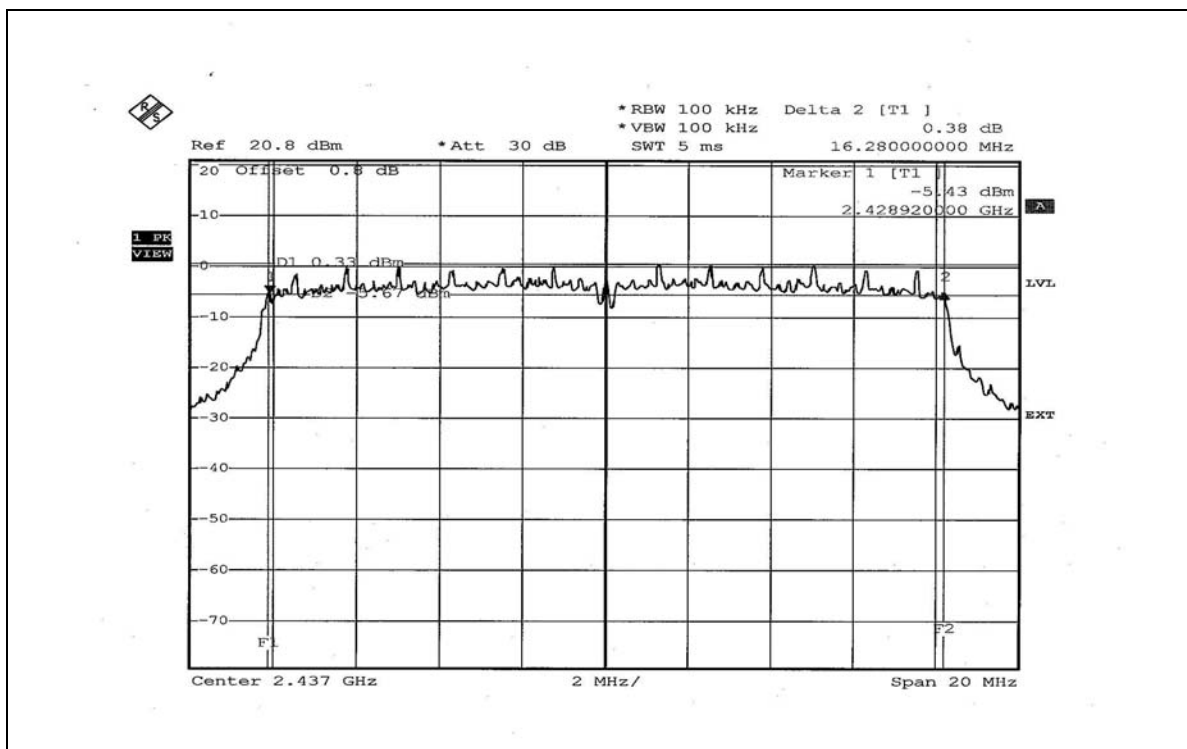

CH 11

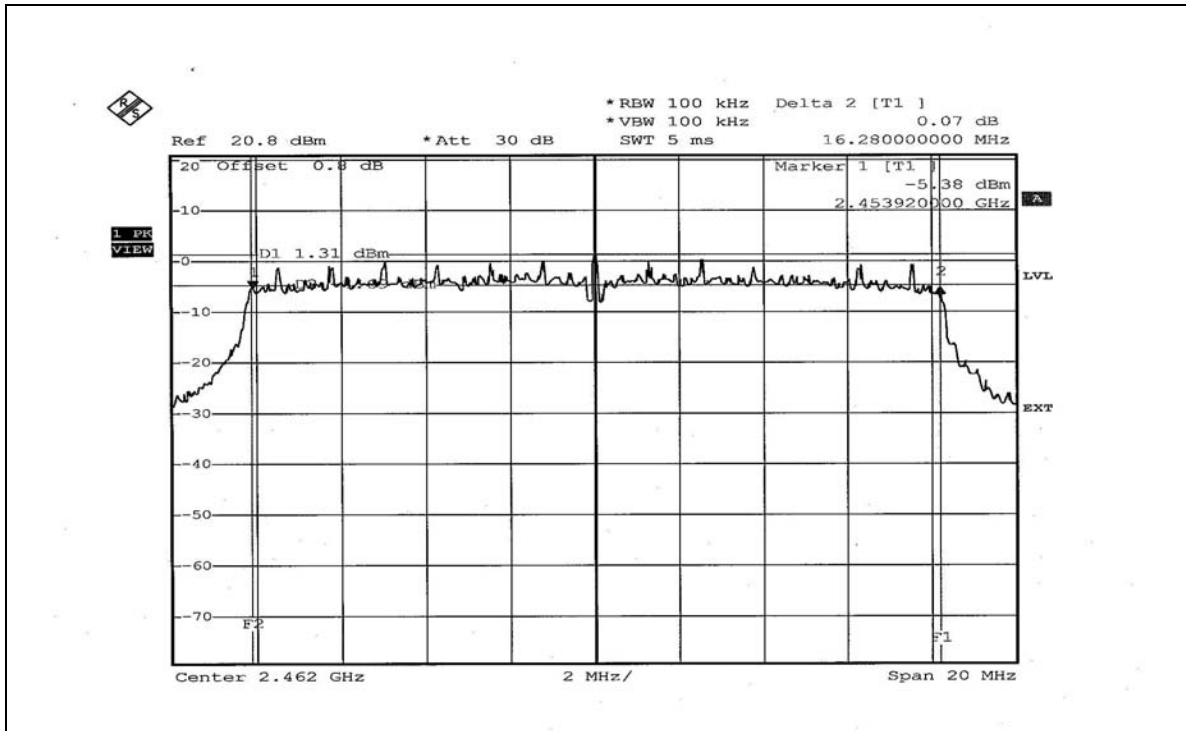



4.4 MAXIMUM PEAK OUTPUT POWER

4.4.1 LIMITS OF MAXIMUM PEAK OUTPUT POWER MEASUREMENT

The Maximum Peak Output Power Measurement is 30dBm.

4.4.2 INSTRUMENTS

Description & Manufacturer	Model No.	Serial No.	Calibrated Until
R&S SPECTRUM ANALYZER	FSEK30	100049	Aug. 14, 2006
AGILENT SIGNAL GENERATOR	E8257C	MY43320668	Dec. 07, 2006
DIGITAL RT OSCILLOSCOPE	TDS1012	C037299	Nov. 28, 2006
NARDA DETECTOR	4503A	FSCM99899	NA

NOTE:

The calibration interval of the above test instruments is 12 months and the calibrations are traceable to NML/ROC and NIST/USA.

4.4.1 TEST PROCEDURES

1. A detector was used on the output port of the EUT. An oscilloscope was used to read the response of the detector.
2. Replaced the EUT by the signal generator. The center frequency of the S.G was adjusted to the center frequency of the measured channel.
3. Adjusted the power to have the same reading on oscilloscope. Record the power level.

4.4.2 DEVIATION FROM TEST STANDARD

No deviation

4.4.3 TEST SETUP



4.4.4 EUT OPERATING CONDITIONS

Same as Item 4.3.6



4.4.3 TEST RESULTS

802.11b DSSS modulation

MODULATION TYPE	DBPSK	TRANSFER RATE	1Mbps
INPUT POWER (SYSTEM)	120Vac, 60 Hz	ENVIRONMENTAL CONDITIONS	26deg.C, 66%RH, 991hPa
TESTED BY	Morgan Chen		

CHANNEL	CHANNEL FREQUENCY (MHz)	PEAK POWER OUTPUT (mW)	PEAK POWER OUTPUT (dBm)	PEAK POWER LIMIT (dBm)	PASS/FAIL
1	2412	41.400	16.17	30	PASS
6	2437	43.053	16.34	30	PASS
11	2462	43.451	16.38	30	PASS

802.11g OFDM modulation

MODULATION TYPE	BPSK	TRANSFER RATE	6Mbps
INPUT POWER (SYSTEM)	120Vac, 60 Hz	ENVIRONMENTAL CONDITIONS	26deg.C, 66%RH, 991hPa
TESTED BY	Morgan Chen		

CHANNEL	CHANNEL FREQUENCY (MHz)	PEAK POWER OUTPUT (mW)	PEAK POWER OUTPUT (dBm)	PEAK POWER LIMIT (dBm)	PASS/FAIL
1	2412	39.994	16.02	30	PASS
6	2437	41.879	16.22	30	PASS
11	2462	40.926	16.12	30	PASS



4.5 POWER SPECTRAL DENSITY MEASUREMENT

4.5.1 LIMITS OF POWER SPECTRAL DENSITY MEASUREMENT

The Maximum of Power Spectral Density Measurement is 8dBm.

4.5.2 TEST INSTRUMENTS

Description & Manufacturer	Model No.	Serial No.	Calibrated Until
R&S SPECTRUM ANALYZER	FSEK30	100049	Aug. 14, 2006

NOTE:

The calibration interval of the above test instruments is 12 months and the calibrations are traceable to NML/ROC and NIST/USA.

4.5.3 TEST PROCEDURE

The transmitter output was connected to the spectrum analyzer through an attenuator, the bandwidth of the fundamental frequency was measured with the spectrum analyzer using 3kHz RBW and 30kHz VBW, set sweep time = span/3kHz. The power spectral density was measured and recorded. The sweep time is allowed to be longer than span/3kHz for a full response of the mixer in the spectrum analyzer.

4.5.4 DEVIATION FROM TEST STANDARD

No deviation

4.5.5 TEST SETUP

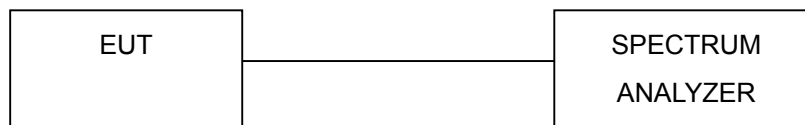

4.5.6 EUT OPERATING CONDITION

Same as Item 4.3.6



4.5.7 TEST RESULTS

802.11b DSSS modulation

MODULATION TYPE	DBPSK	TRANSFER RATE	1Mbps
INPUT POWER (SYSTEM)	120Vac, 60 Hz	ENVIRONMENTAL CONDITIONS	26deg.C, 66%RH, 991hPa
TESTED BY	Morgan Chen		

CHANNEL	CHANNEL FREQUENCY (MHz)	RF POWER LEVEL IN 3kHz BW (dBm)	MAXIMUM LIMIT (dBm)	PASS/FAIL
1	2412	0.69	8	PASS
6	2437	0.71	8	PASS
11	2462	0.77	8	PASS

CH 1

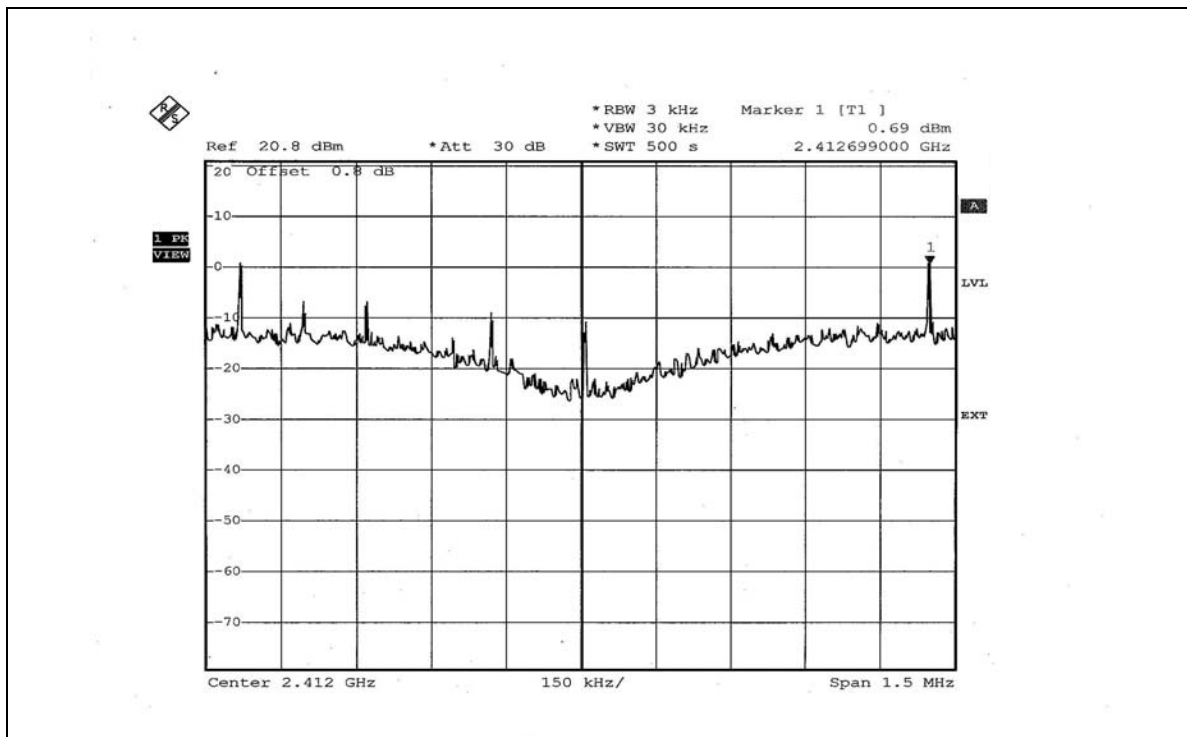

CH 6

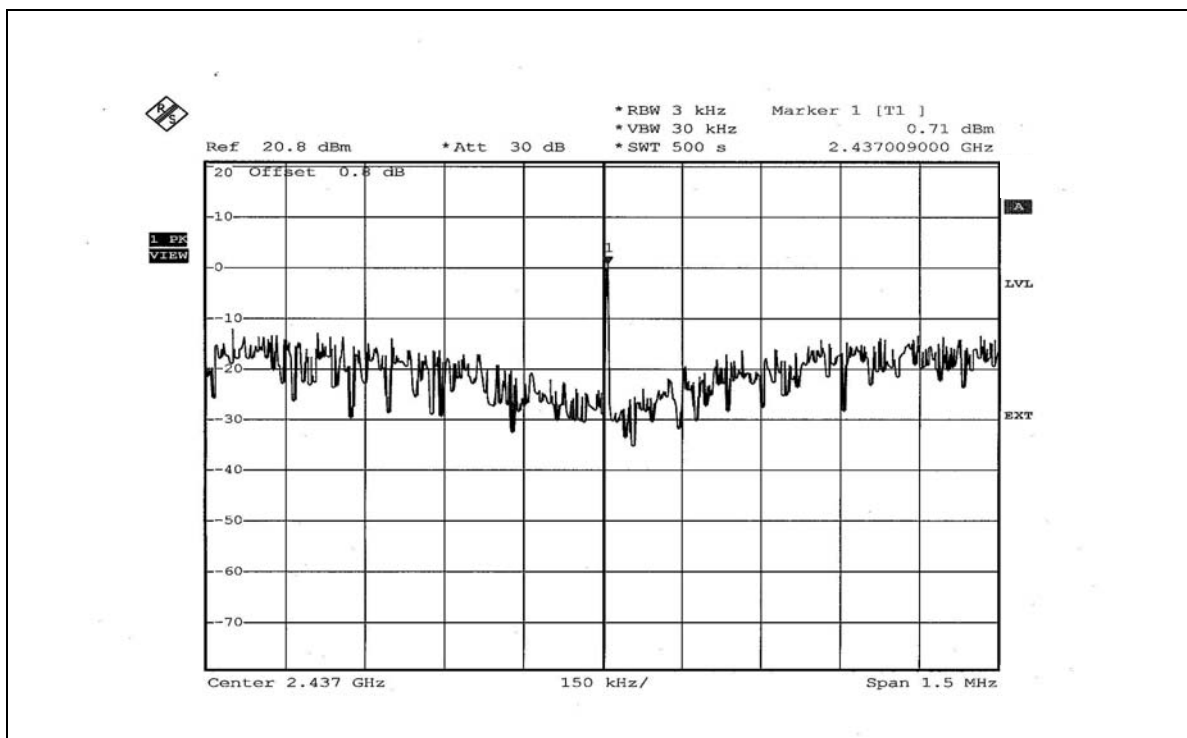

CH 11

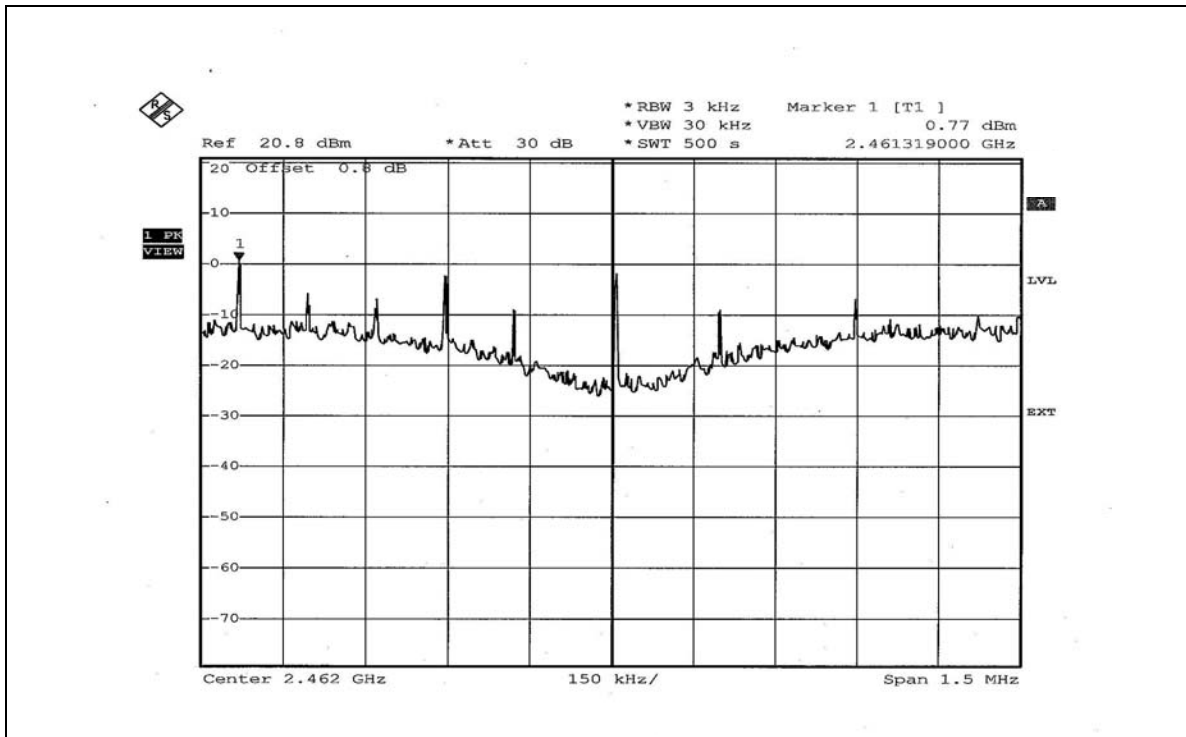



802.11g OFDM modulation

MODULATION TYPE	BPSK	TRANSFER RATE	6Mbps
INPUT POWER (SYSTEM)	120Vac, 60 Hz	ENVIRONMENTAL CONDITIONS	26deg.C, 66%RH, 991hPa
TESTED BY	Morgan Chen		

CHANNEL	CHANNEL FREQUENCY (MHz)	RF POWER LEVEL IN 3kHz BW (dBm)	MAXIMUM LIMIT (dBm)	PASS/FAIL
1	2412	-13.12	8	PASS
6	2437	-13.97	8	PASS
11	2462	-13.90	8	PASS

CH 1

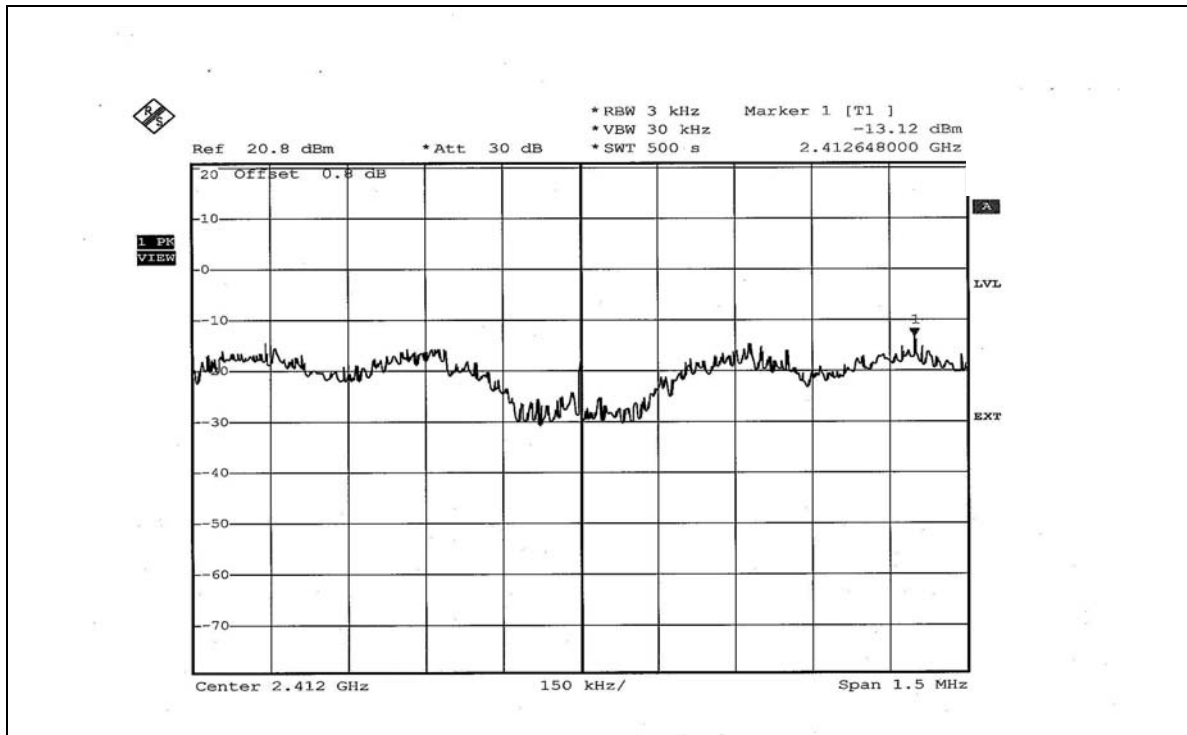

CH 6

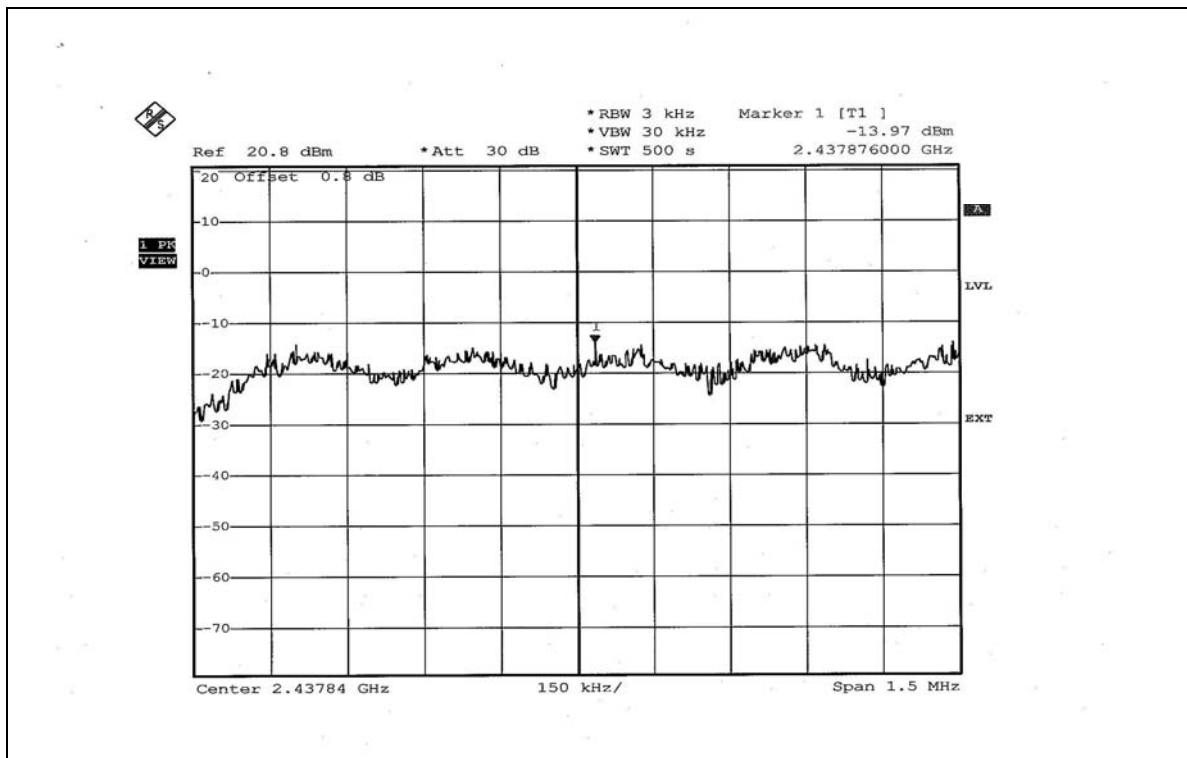

CH 11

