

- 01:G733G M/B DESCRIPTION
- 02:Pentium4_LGA775-1
- 03:Pentium4_LGA775-2
- 04:Pentium4_LGA775-3 & LM90
- 05:661FX (HOST/AGP)
- 06:661FX (RAM CONTROLLER)
- 07:661FX (HYPERZIP/AGP)
- 08:661FX (POWER)
- 09:963 (PCI/IDE)
- 10:963 (MISC.)
- 11:963 (USB CONTROLLER)
- 12:963 (POWER)
- 13:CLOCK GENERATOR
- 14:CLOCK BUFFER FOR DDR
- 15:DDR SODIMM & MDC
- 16:DDR_RES VTT
- 17:CRT & PRN CONN.
- 18:AC97 & AMPLIFIER
- 19:HDD & CD-ROM CONN.
- 20:KEYBOARD CONTROLLER
- 21:ITE8705F LPC SUPER IO
- 22:LVDS INTERFACE (SIS 302LV)
- 23:LCD & TV CONN.
- 24:ENE 1410 CONTROLLER
- 25:PCMCIA CONN.
- 26:POWER LED & RJ11 & STATUS
- 27:USB PORT & USBLAN
- 28:RTL8201 LAN PHY
- 29:AgereFW802C 1394 PHY
- 30:RTC & POWER SW
- 31:ADAPTOR/BATTERY SELECT
- 32:MB3887 CHARGER
- 33:MAX1999 SYSTEM POWER
- 34:MAX1546 CPU POWER
- 35:MAX1980
- 36:CHIPSET POWER & DDR2.5V
- 37:LDO & DDRVTT POWER
- 38:CPU_VTT_MAX1714
- 39:HISTORY

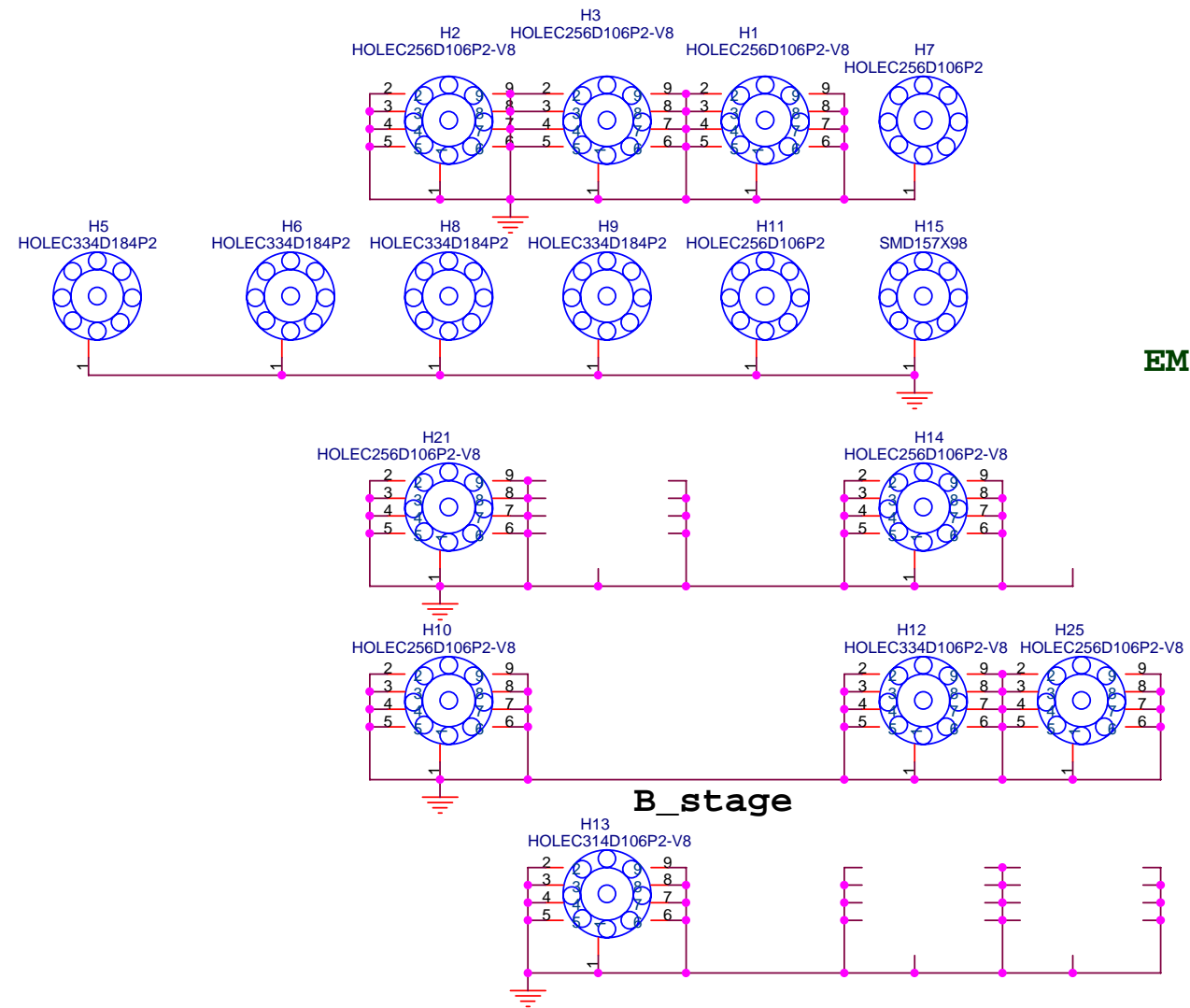
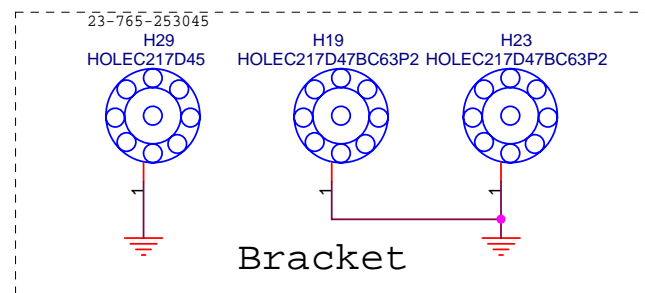
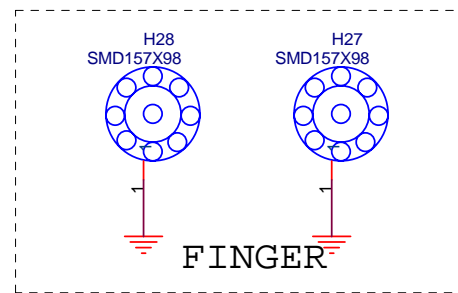
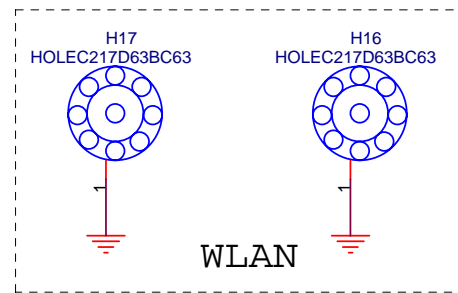
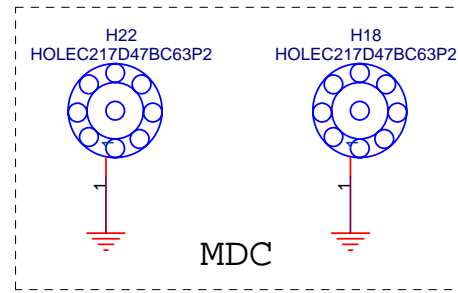

X = 0805 TYPE
 Y = 1206 TYPE
 C3216 = A TYPE
 C3528 = B TYPE
 C6032 = C TYPE
 C7343 = D TYPE

P/N:15-F46-014002

PAGE	01	02	03	04	05	06	07	08	09	10	11	12	13	14	15	16	17	18	19
REV	4.0	4.0	4.0	4.0	4.0	4.0	4.0	4.0	4.0	4.0	4.0	4.0	4.0	4.0	4.0	4.0	4.0	4.0	4.0
DATE	1/12	1/12	1/12	1/12	1/12	1/12	1/12	1/12	1/12	1/12	1/12	1/12	1/12	1/12	1/12	1/12	1/12	1/12	1/12

PAGE	20	21	22	23	24	25	26	27	28	29	30	31	32	33	34	35	36	37	38	39
REV	4.0	4.0	4.0	4.0	4.0	4.0	4.0	4.0	4.0	4.0	4.0	4.0	4.0	4.0	4.0	4.0	4.0	4.0	4.0	4.0
DATE	1/12	1/12	1/12	1/12	1/12	1/12	1/12	1/12	1/12	1/12	1/12	1/12	1/12	1/12	1/12	1/12	1/12	1/12	1/12	1/12

ECS CORP. (G733G M/B)		
Title G733E M/B DESCRIPTION		
Size A3	Document Number G733G-1-3-01	Rev 4.0
Date: Wednesday, January 12, 2005	Sheet 1	of 39

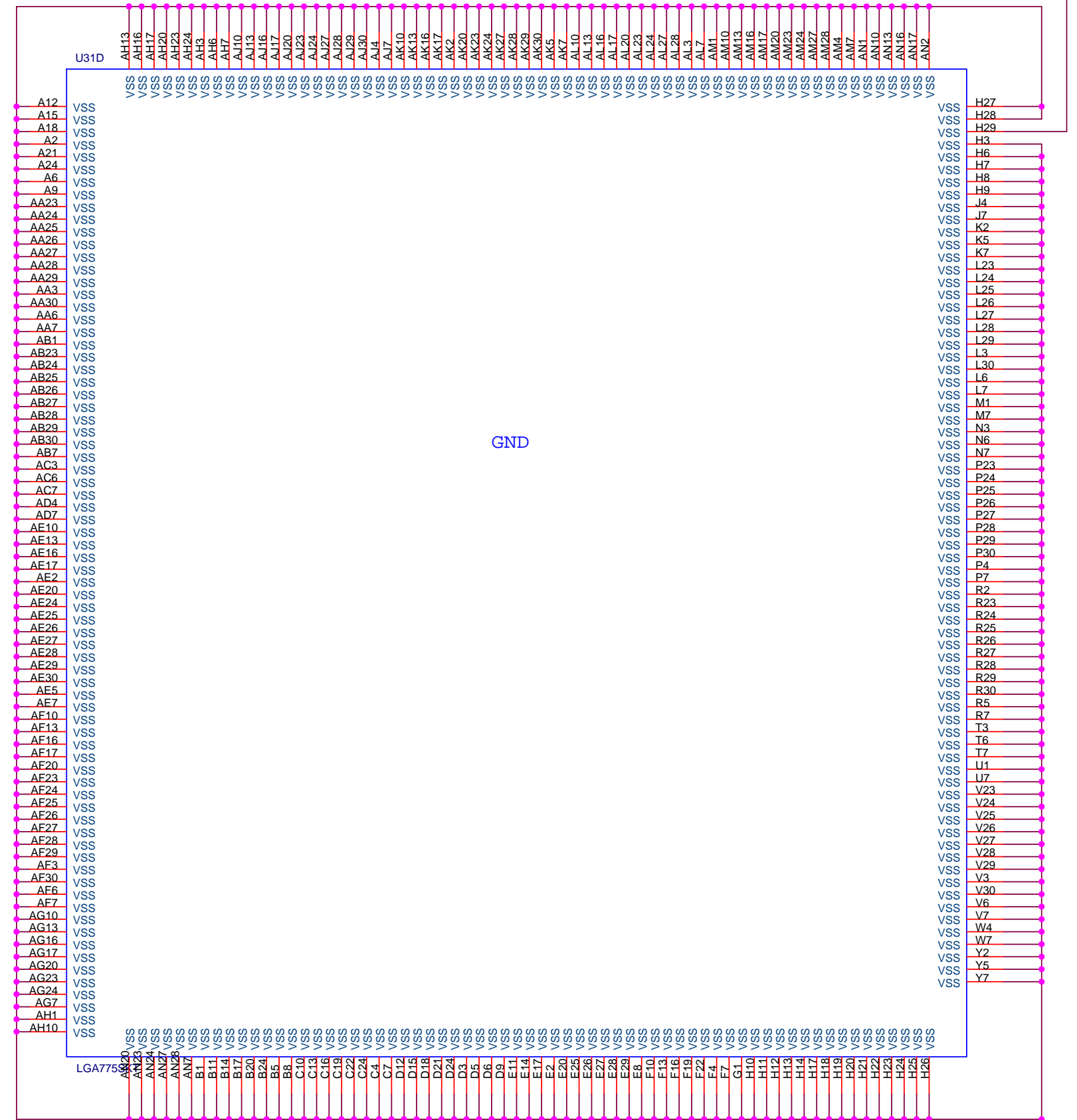
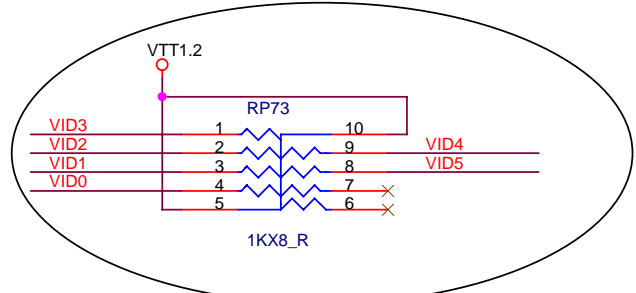
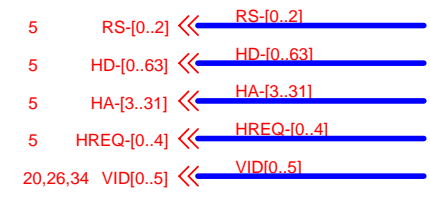
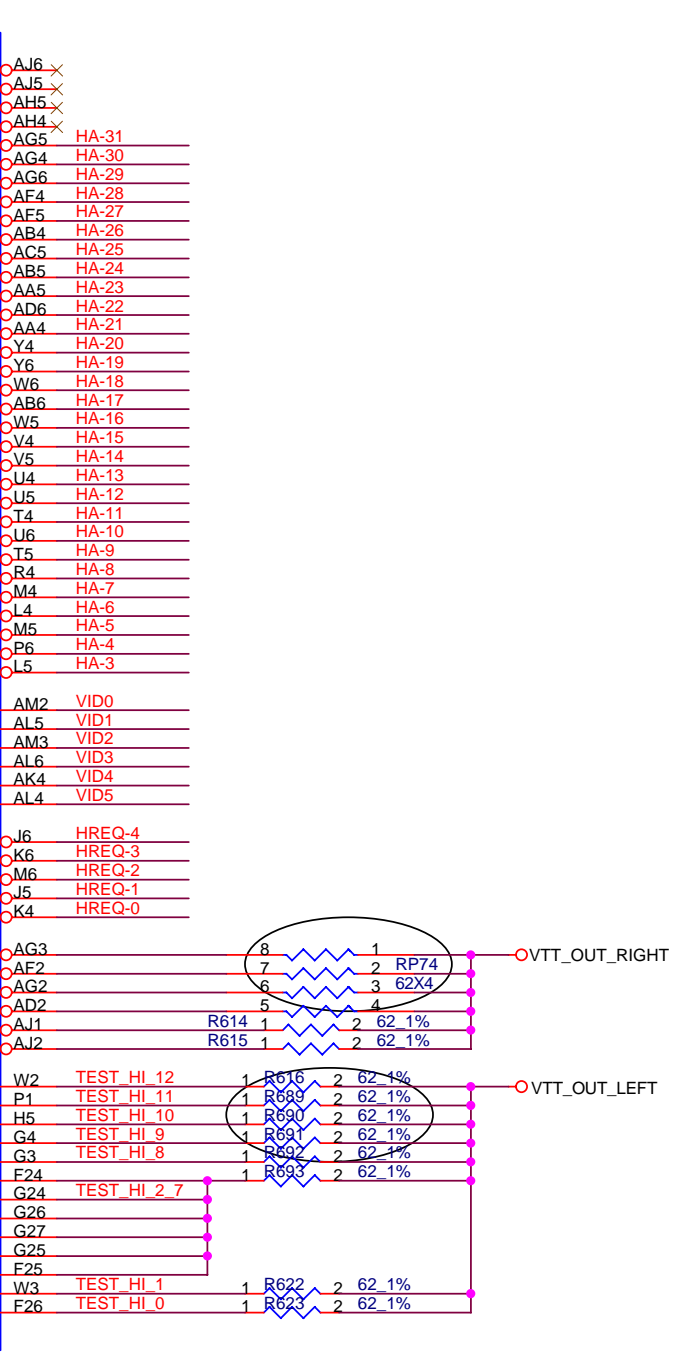
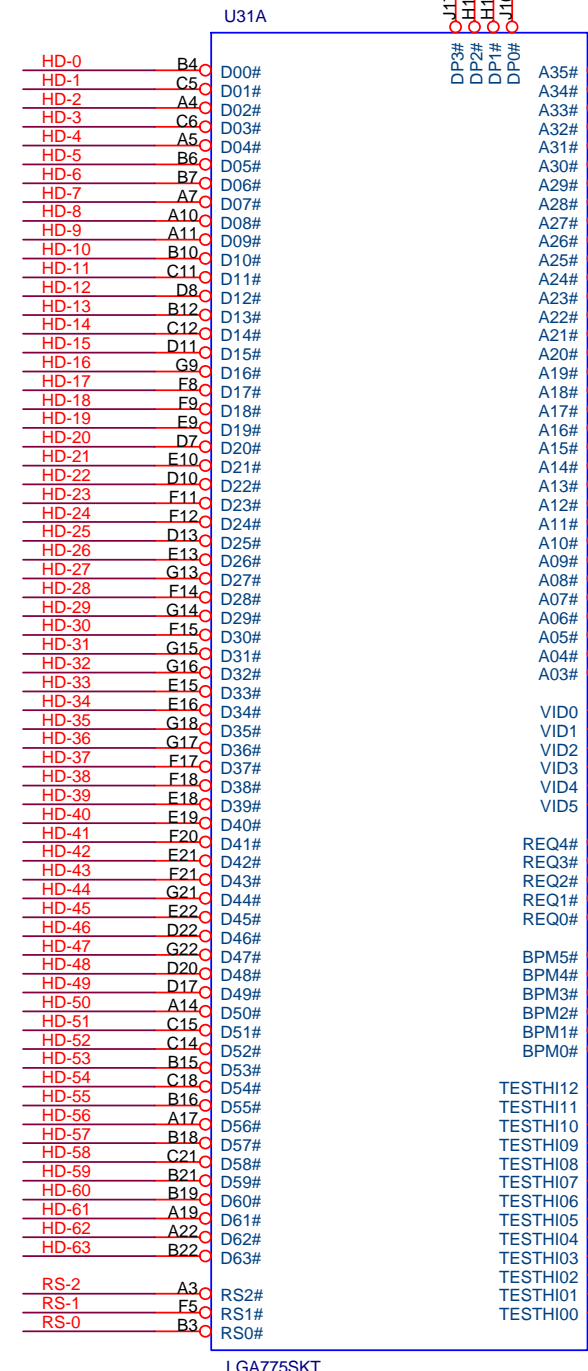

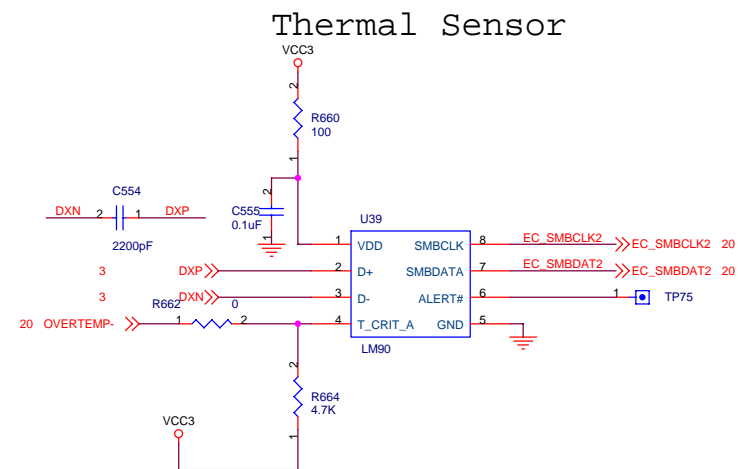
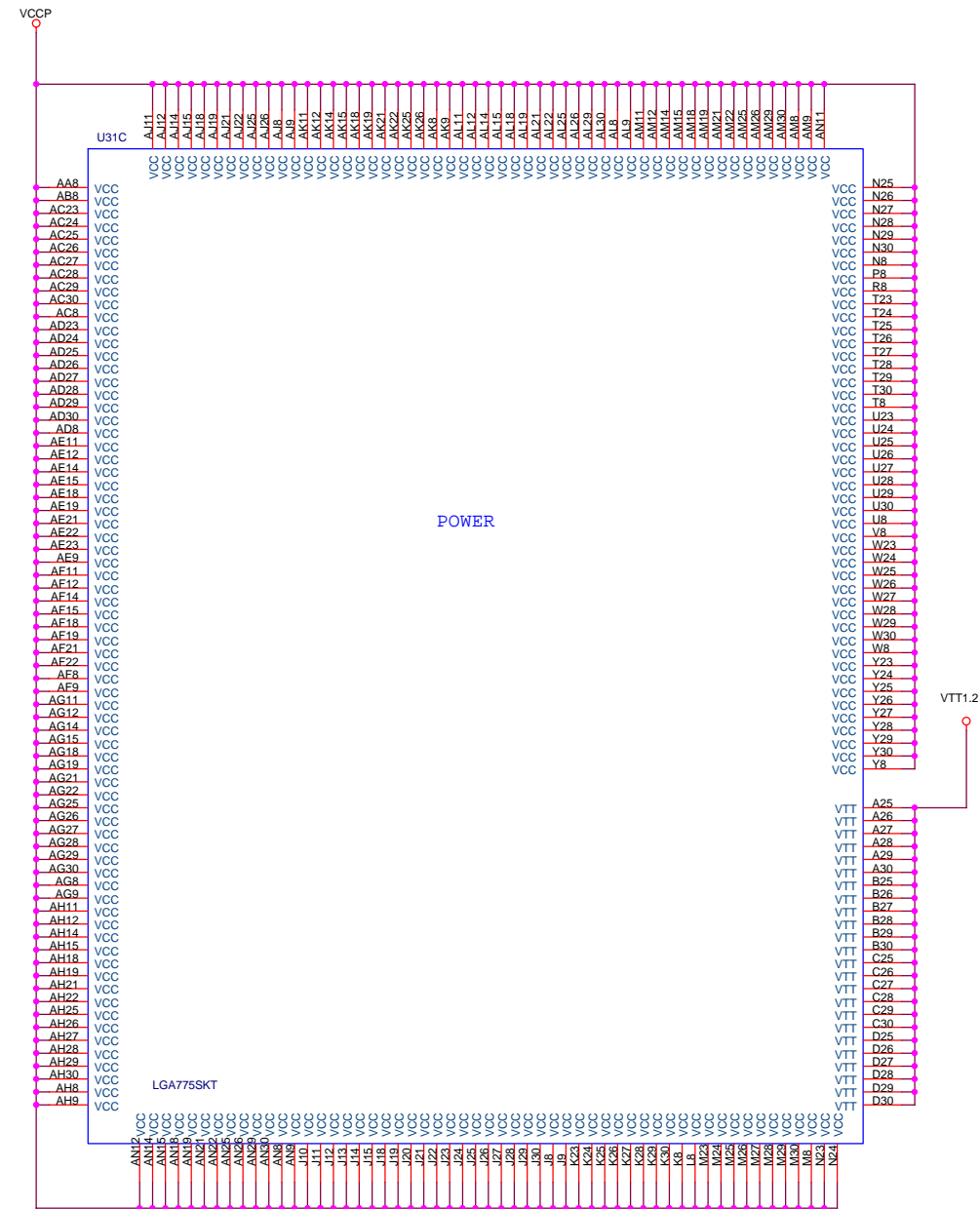
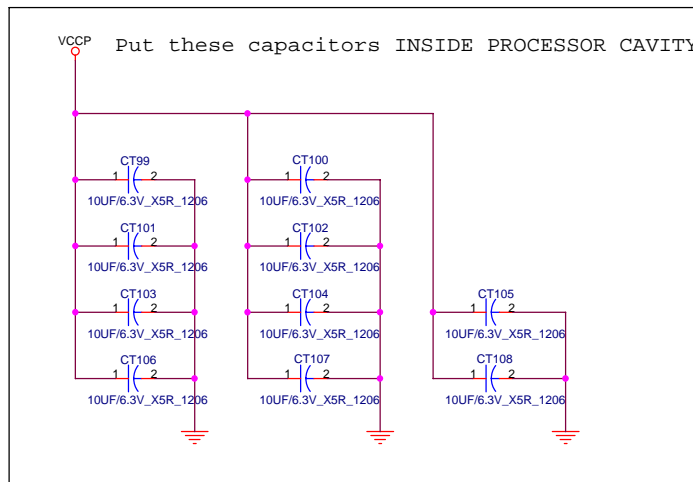
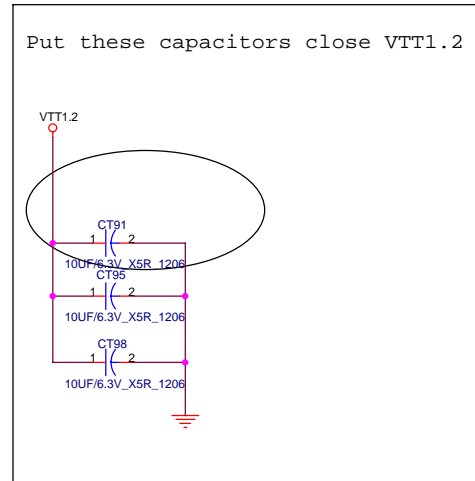
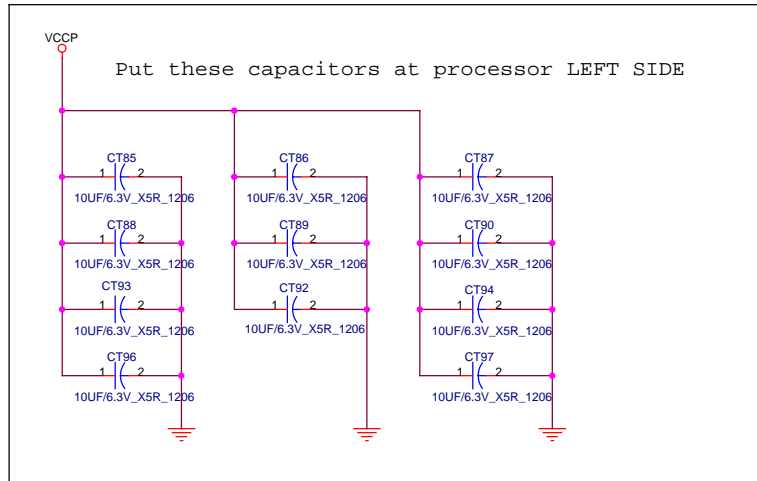
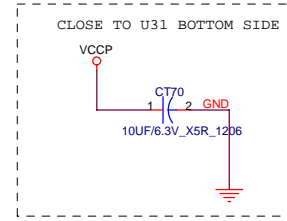
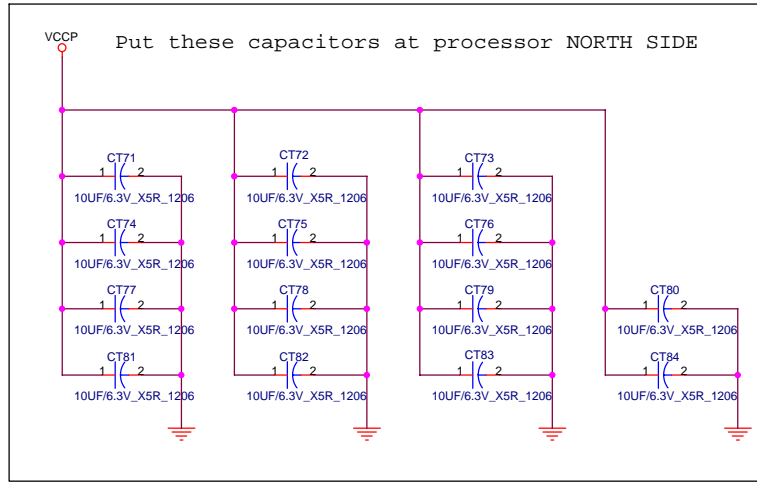

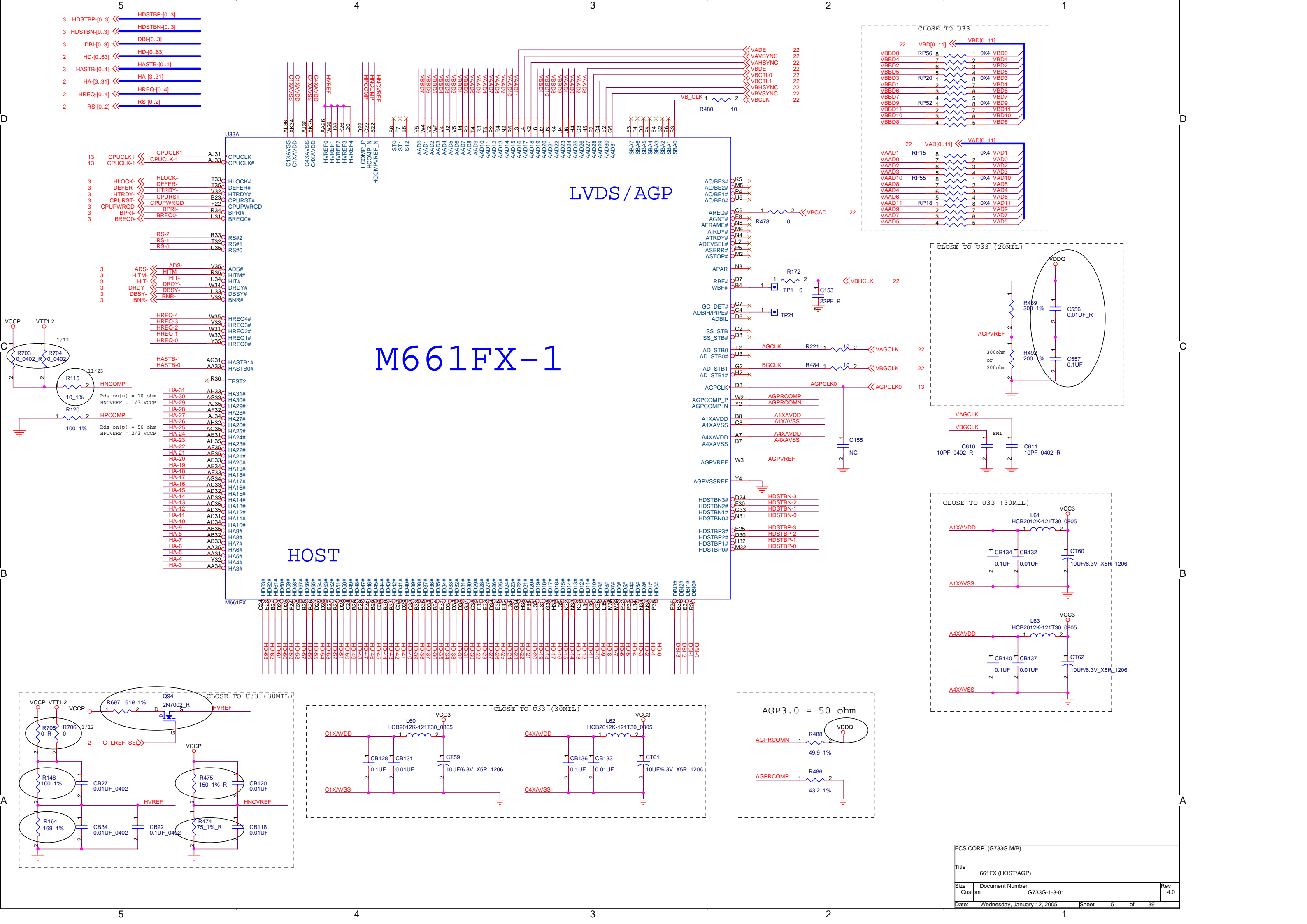

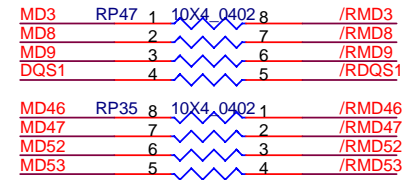
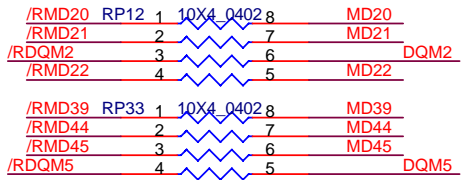

Resistors place close to DIMM1

Rs place close to DIMM1

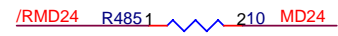
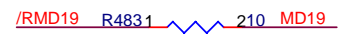
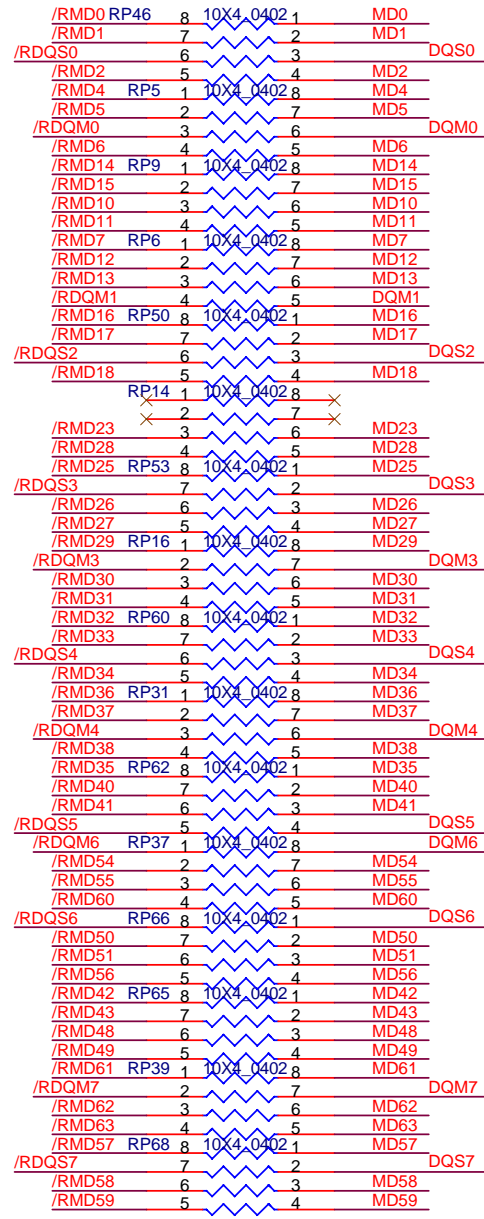

MD0	AN35	MD0
MD1	AP36	MD1
MD2	AK33	MD2
MD3	AM33	MD3
MD4	AN34	MD4
MD5	AK32	MD5
MD6	AR34	MD6
MD7	AN33	MD7
DQM0	AR35	DQM0
DQS0	AP34	DQS0
MD8	AM32	MD8
MD9	AL31	MD9
MD10	AR31	MD10
MD11	AL30	MD11
MD12	AN32	MD12
MD13	AR33	MD13
MD14	AN31	MD14
MD15	AM31	MD15
DQM1	AR32	DQM1
DQS1	AP32	DQS1
MD16	AP30	MD16
MD17	AR30	MD17
MD18	AM29	MD18
MD19	AL27	MD19
MD20	AN30	MD20
MD21	AN29	MD21
MD22	AL28	MD22
MD23	AN28	MD23
DQM2	AL29	DQM2
DQS2	AR29	DQS2
MD24	AP26	MD24
MD25	AN25	MD25
MD26	AR24	MD26
MD27	AL24	MD27
MD28	AL25	MD28
MD29	AR26	MD29
MD30	AM25	MD30
MD31	AN24	MD31
DQM3	AP24	DQM3
DQS3	AR25	DQS3
MD32	AN21	MD32
MD33	AP20	MD33
MD34	AN20	MD34
MD35	AL18	MD35
MD36	AM21	MD36
MD37	AR21	MD37
MD38	AL19	MD38
MD39	AM19	MD39
DQM4	AL20	DQM4
DQS4	AR20	DQS4
MD40	AL15	MD40
MD41	AL14	MD41
MD42	AN15	MD42
MD43	AR15	MD43
MD44	AN16	MD44
MD45	AM15	MD45
MD46	AN14	MD46
MD47	AL13	MD47
DQM5	AP16	DQM5
DQS5	AR16	DQS5
MD48	AM13	MD48
MD49	AL12	MD49
MD50	AL11	MD50
MD51	AR12	MD51
MD52	AP14	MD52
MD53	AR14	MD53
MD54	AN13	MD54
MD55	AP12	MD55
DQM6	AN12	DQM6
DQS6	AR13	DQS6
MD56	AL10	MD56
MD57	AR11	MD57
MD58	AM9	MD58
MD59	AR9	MD59
MD60	AM11	MD60
MD61	AN11	MD61
MD62	AP10	MD62
MD63	AN9	MD63
DQM7	AN10	DQM7
DQS7	AR10	DQS7

M661FX-2

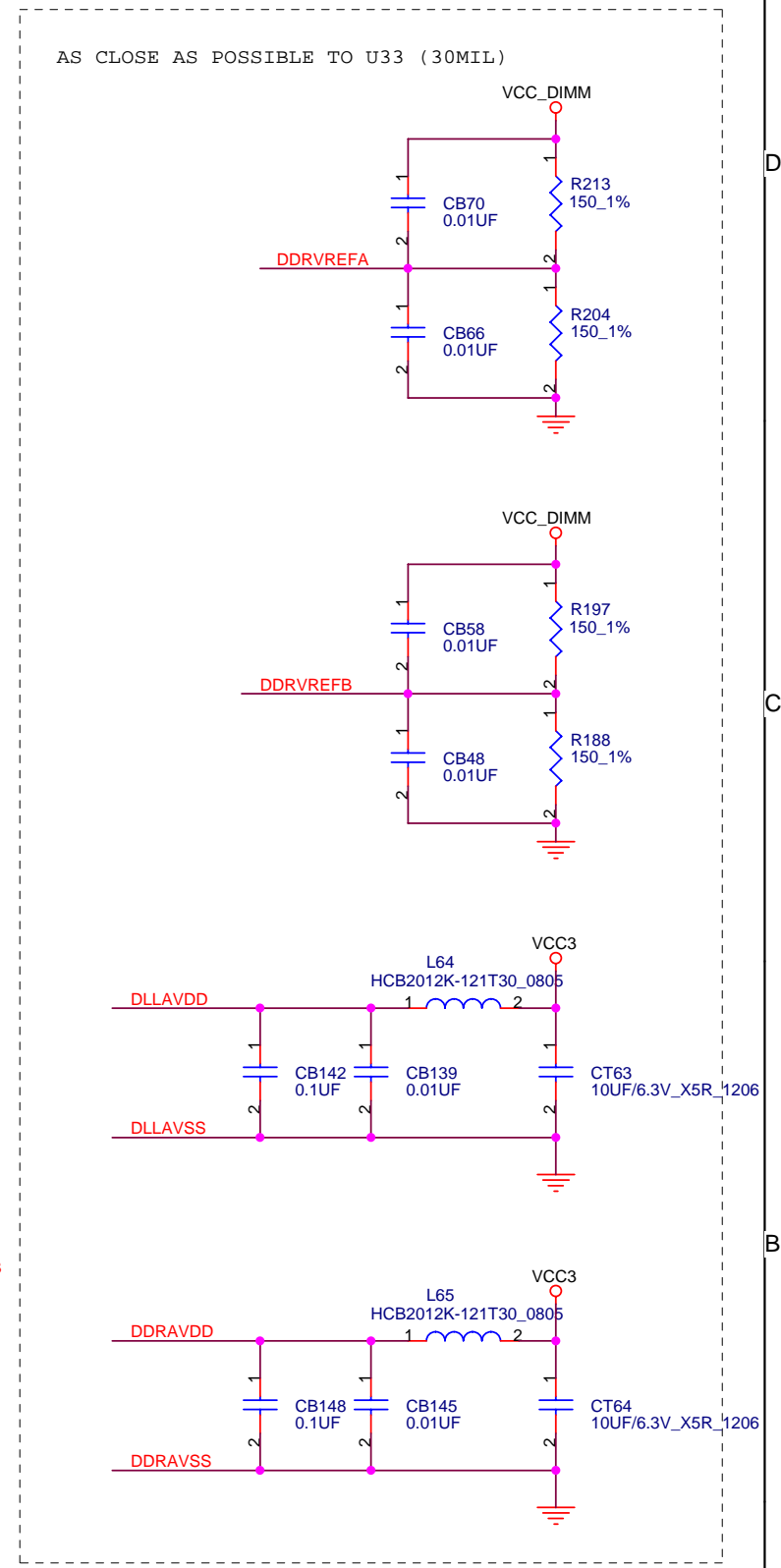
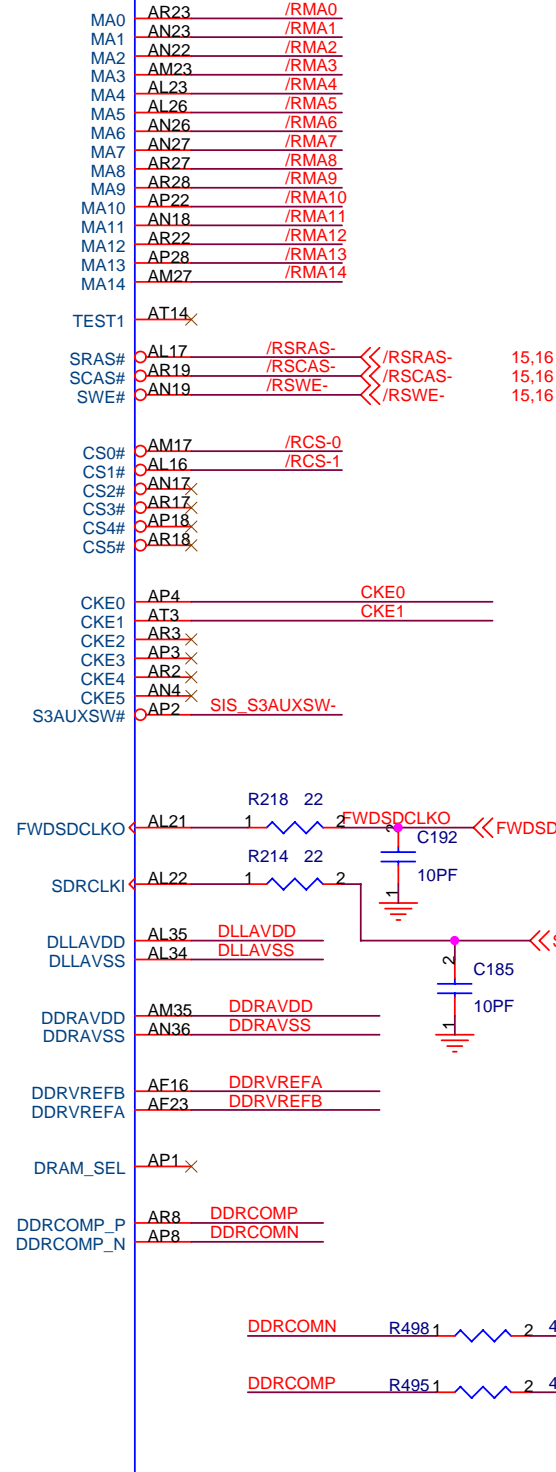

9 ZAD[0..16] << ZAD[0..16]
 9 ZSTB[0..1] << ZSTB[0..1]
 9 ZSTB-[0..1] << ZSTB-[0..1]

		ENABLE	DISABLE
RSYNC	VGA	1	0
LSYNC	PANEL LINK	1	0
CSYNC	VB	1	0

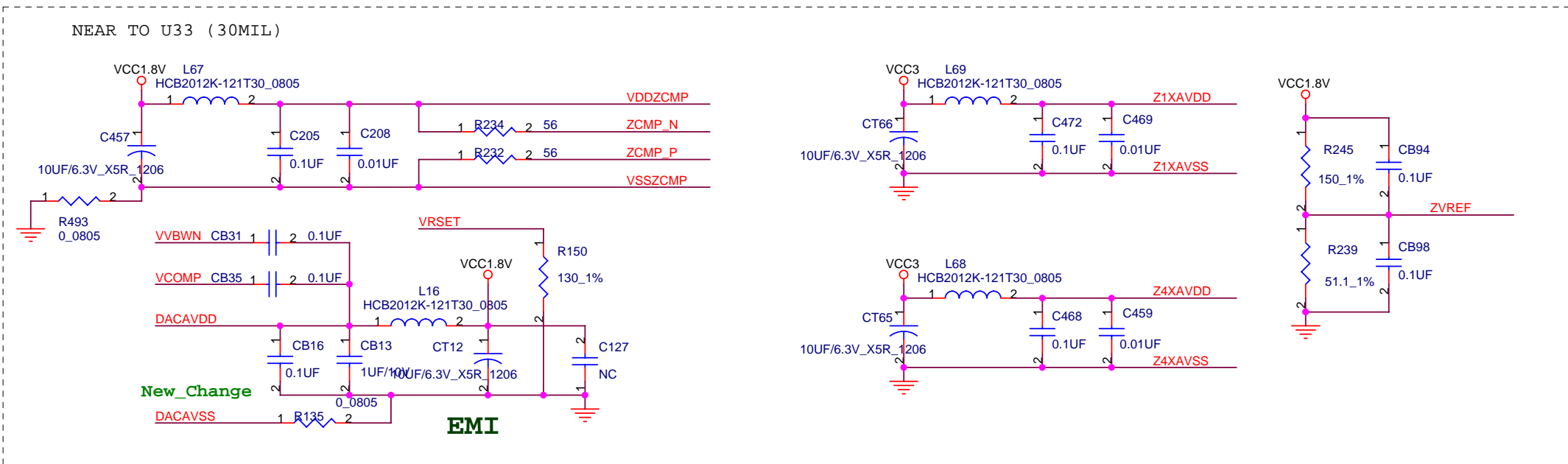
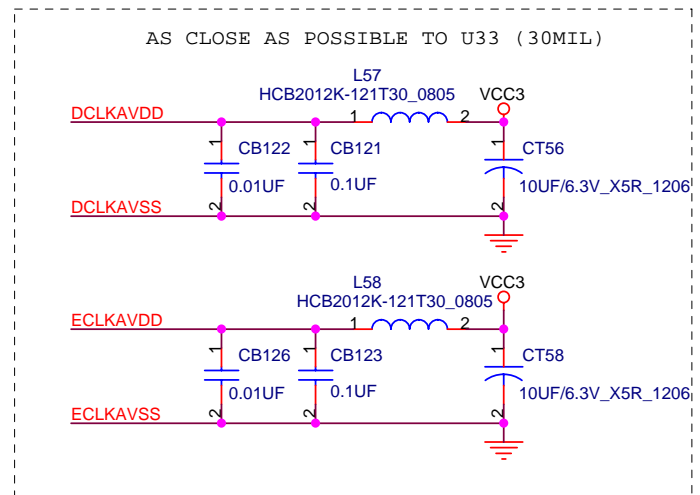
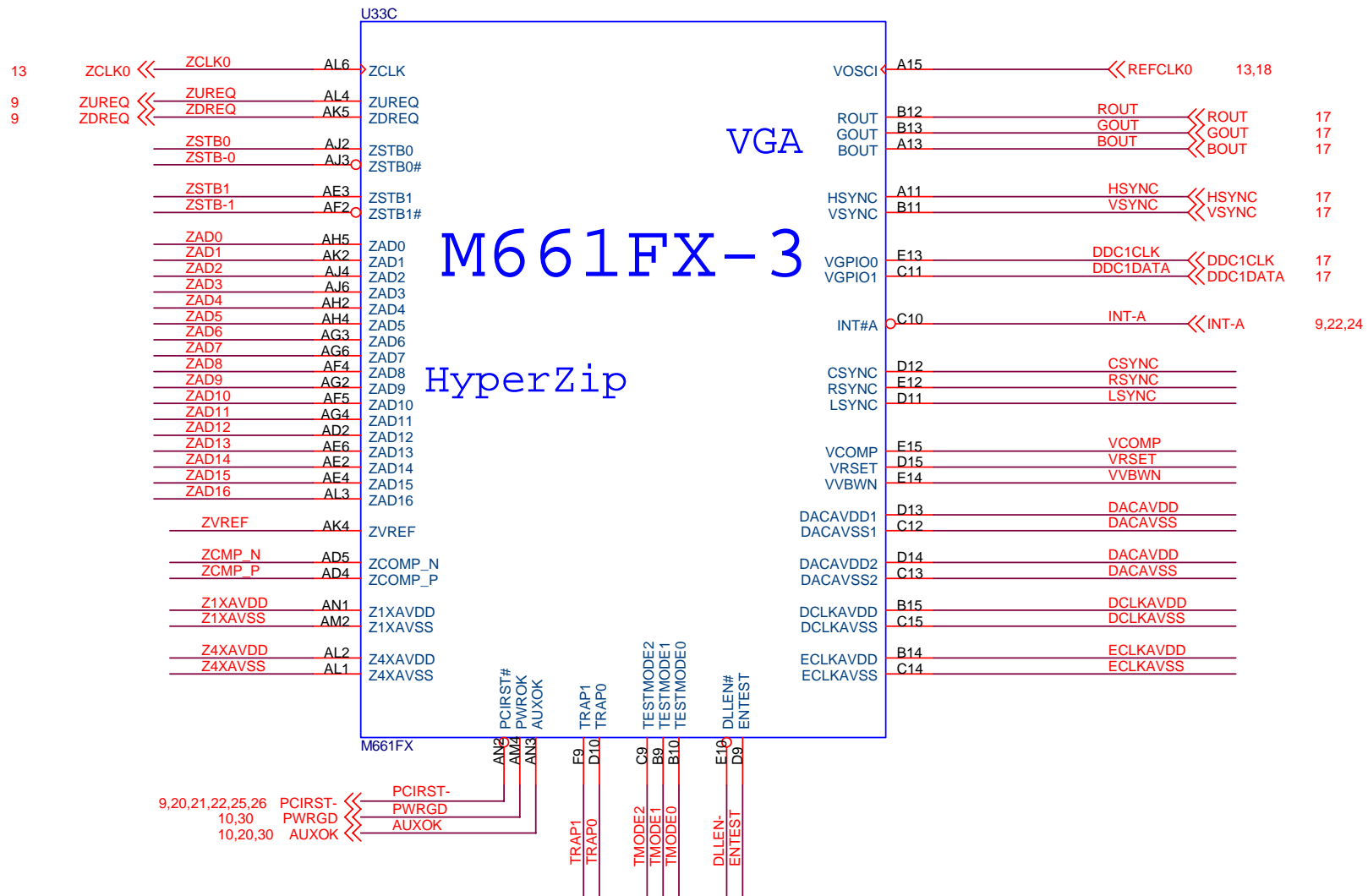
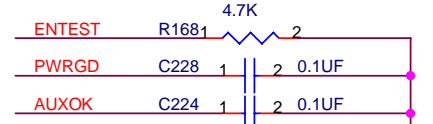
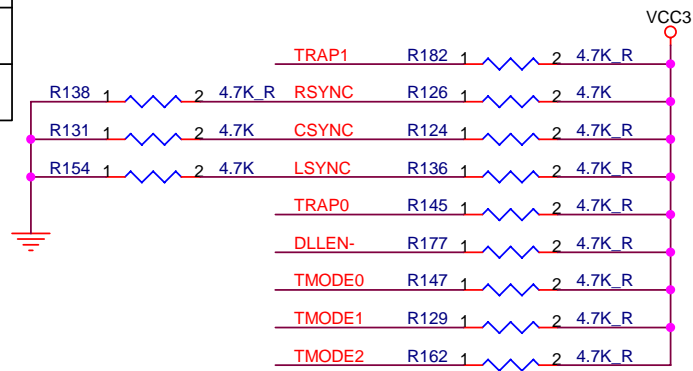

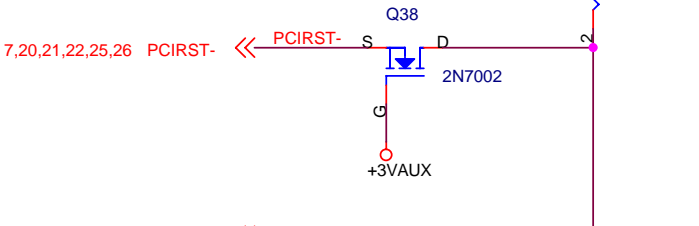
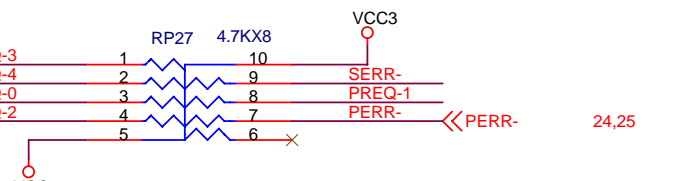
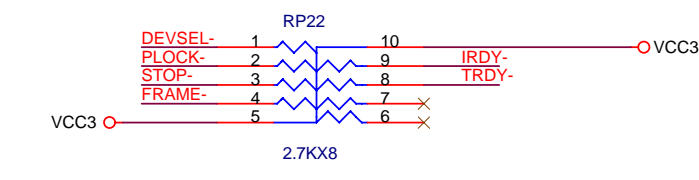
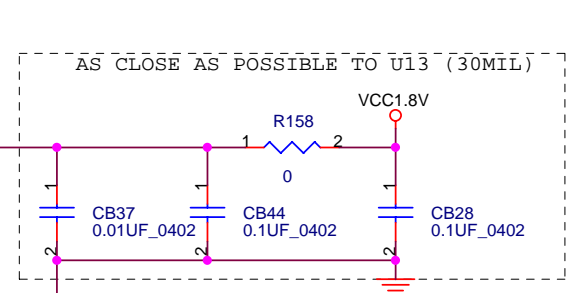
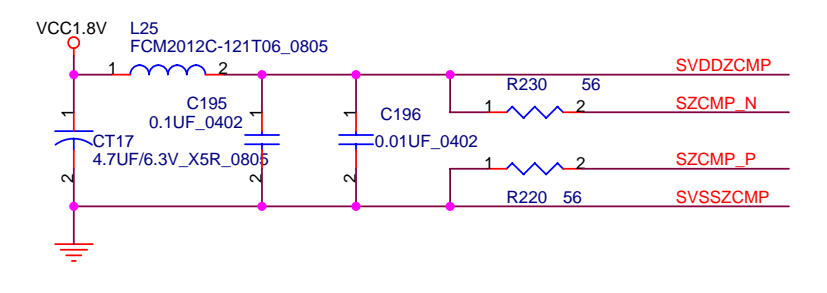
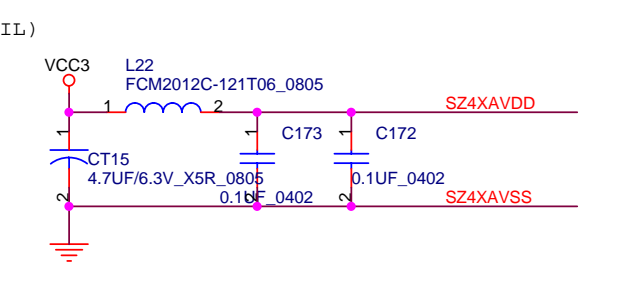
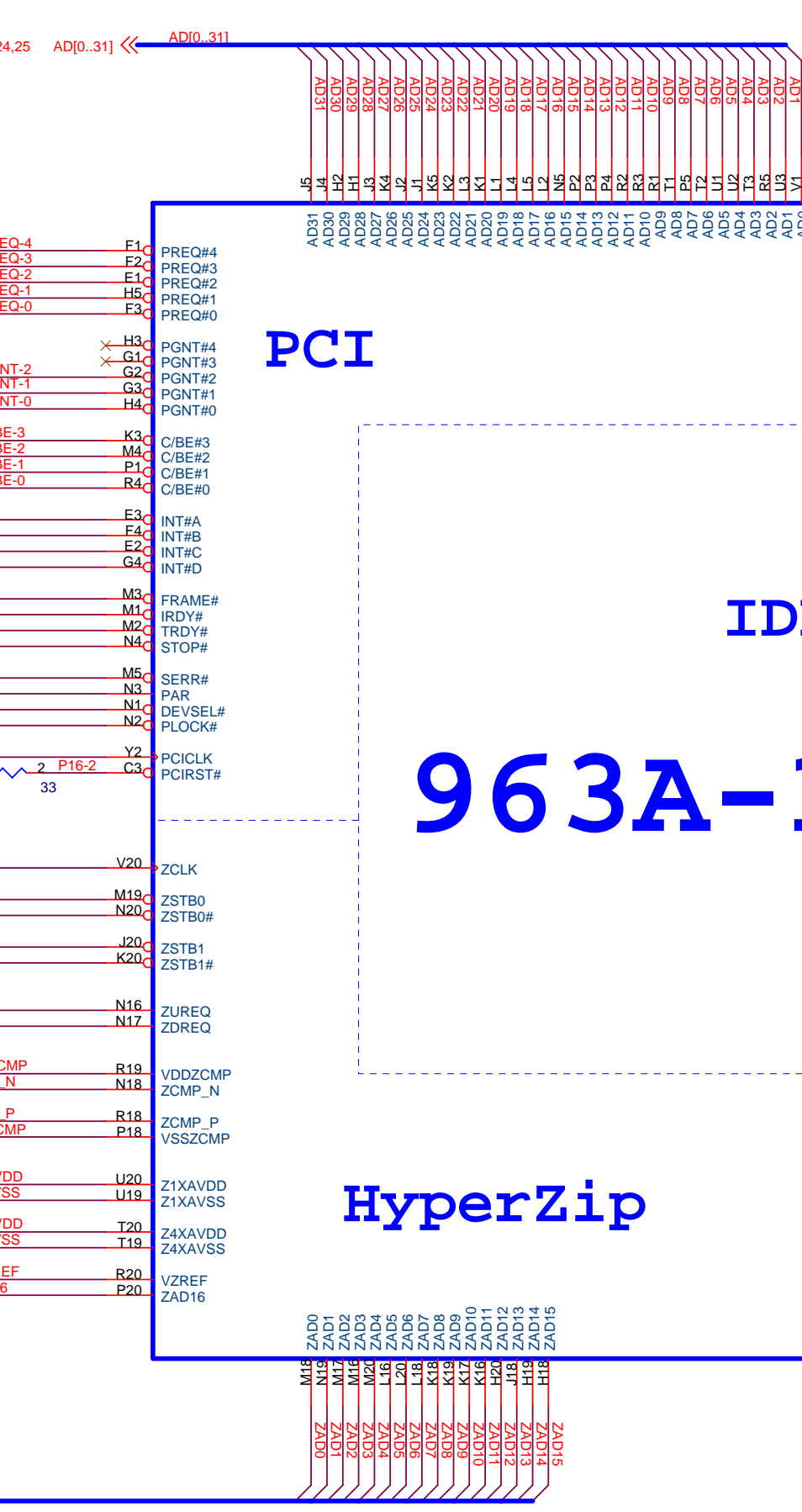
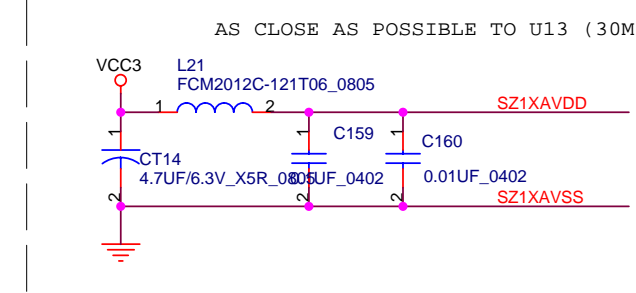
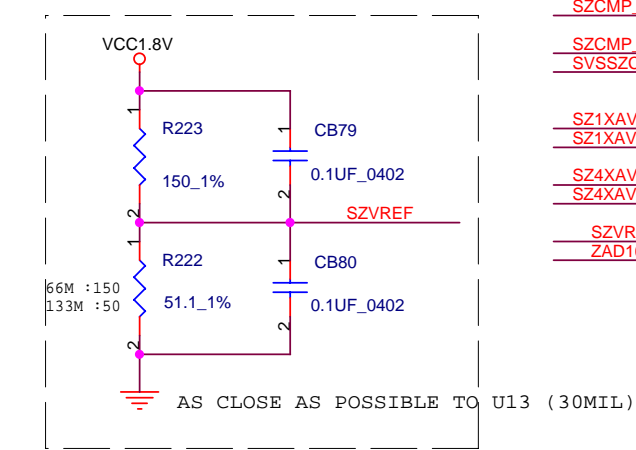
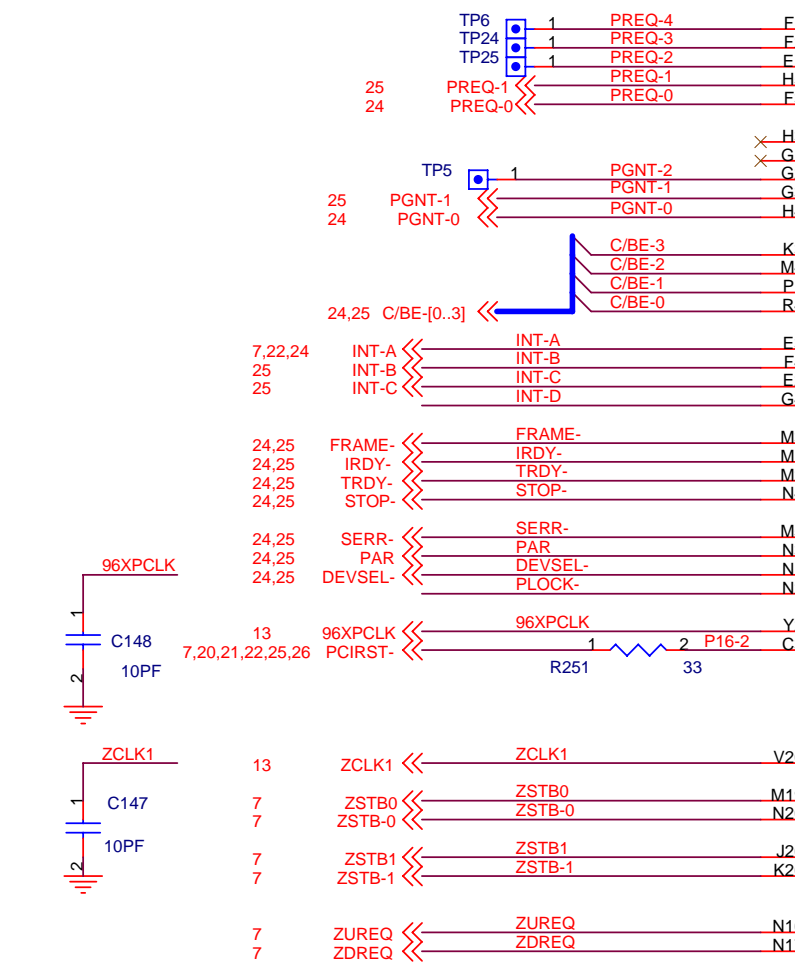
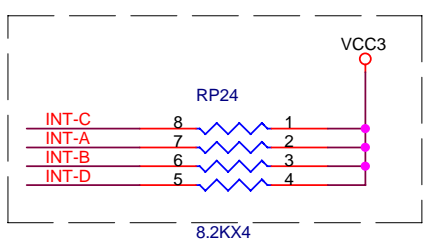

ECS CORP. (G733G M/B)		
Title	963(PCI/IDE)	
Size	Document Number	Rev
Custom	G733G-1-3-01	4.0
Date:	Wednesday, January 12, 2005	Sheet 9 of 39

Programable on-die pull-high strength for CPU_S:
(Infinite, 150, 110, 56 Ohm)

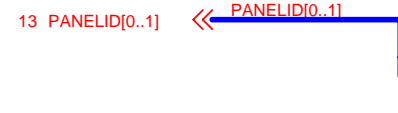
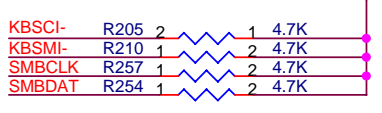
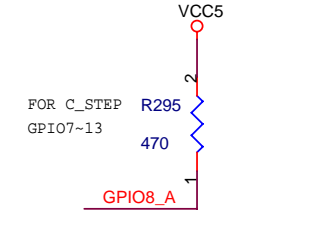
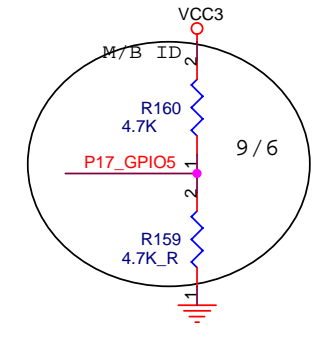
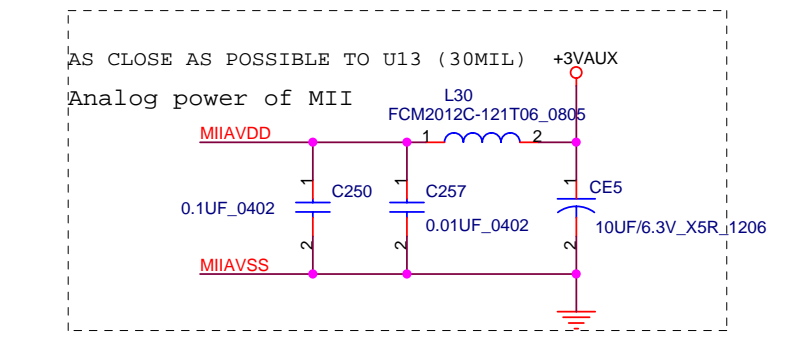
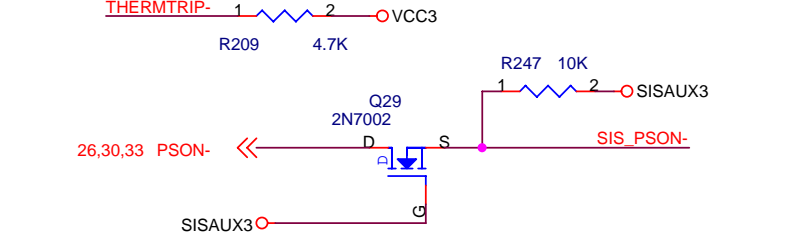
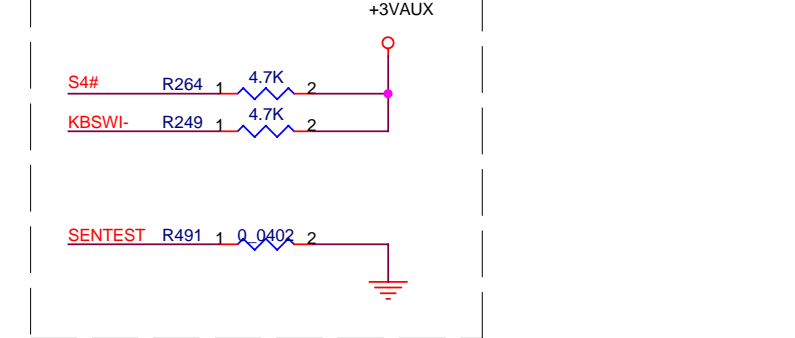
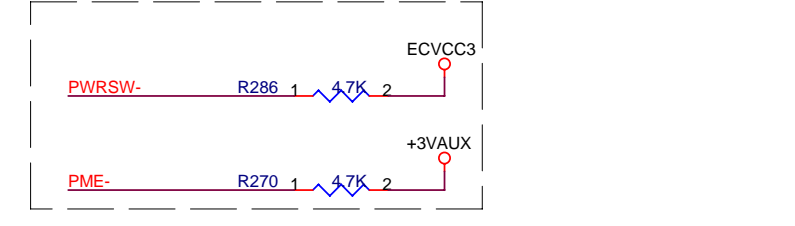
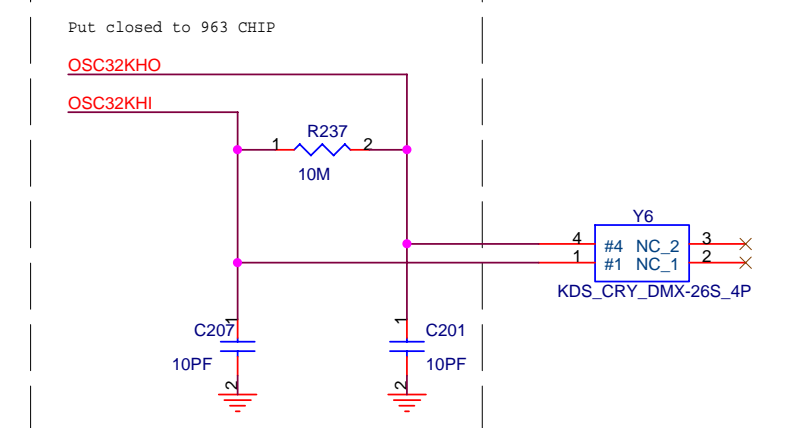
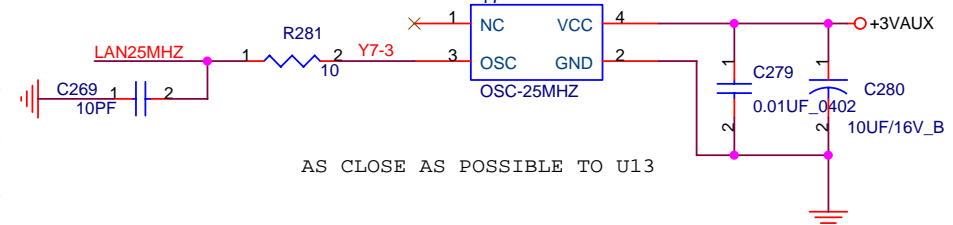
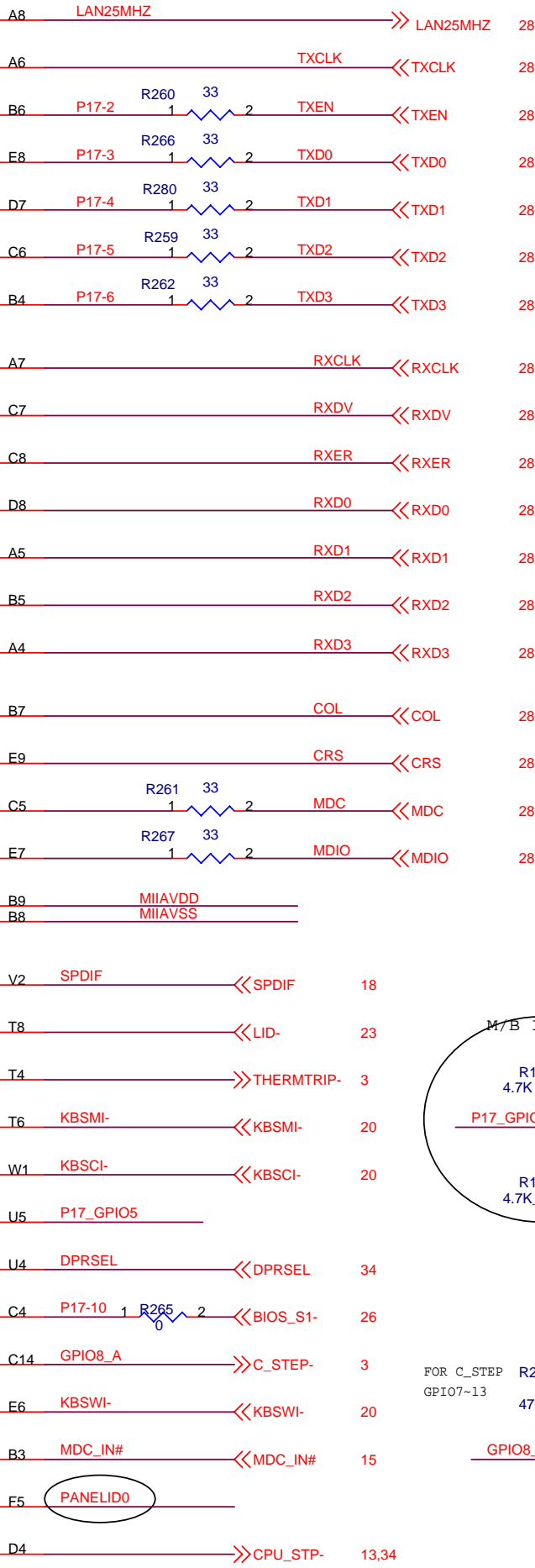
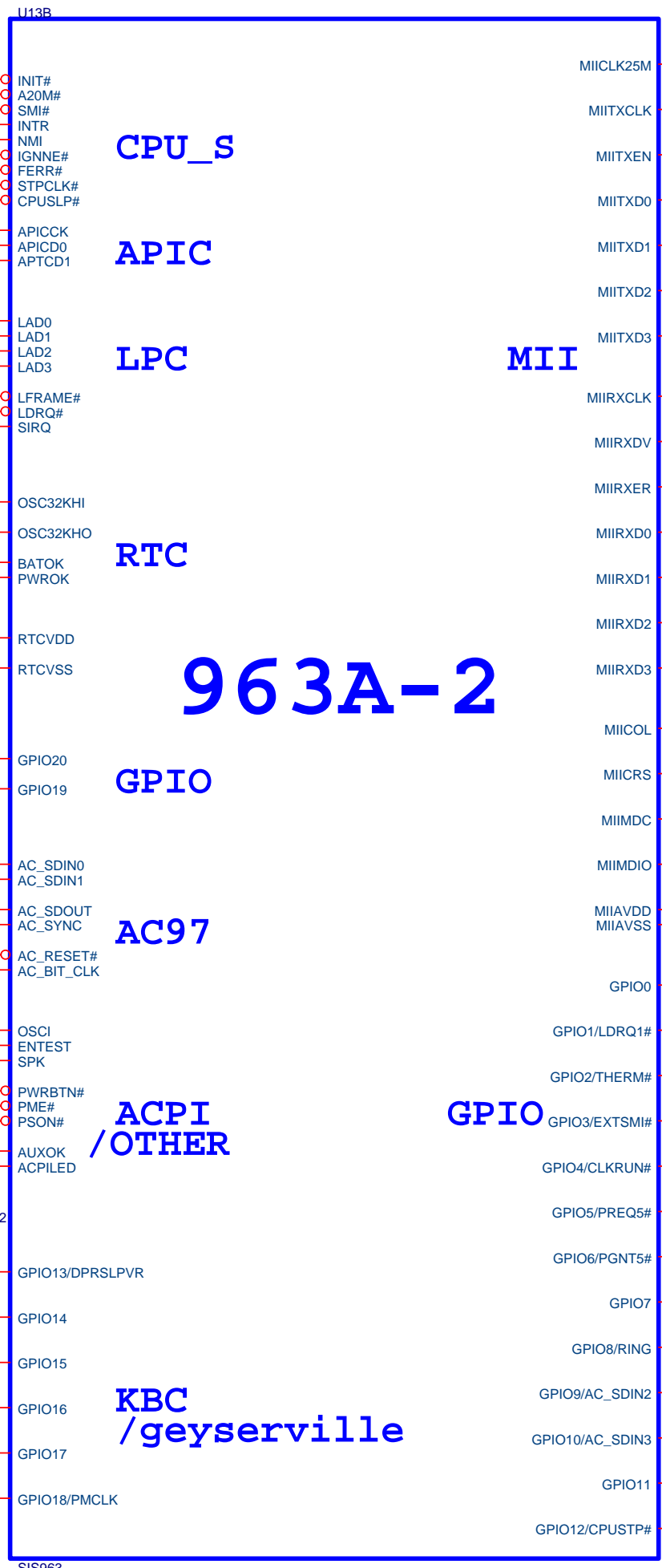
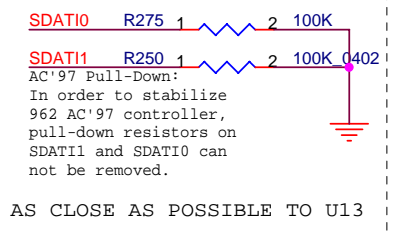
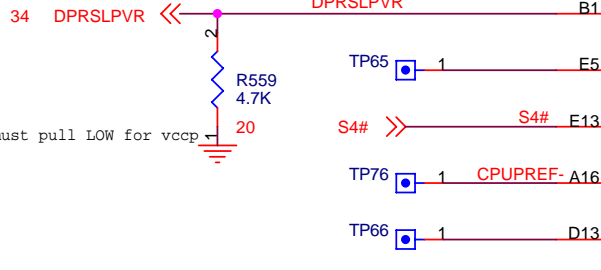
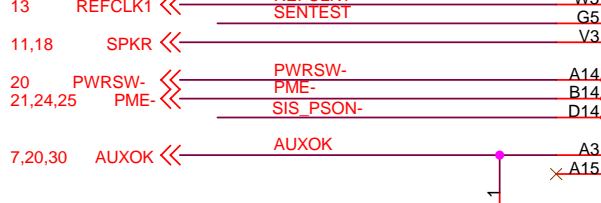
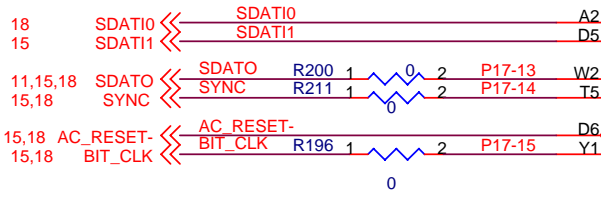
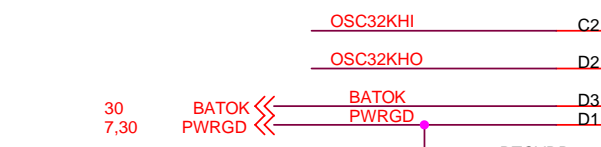
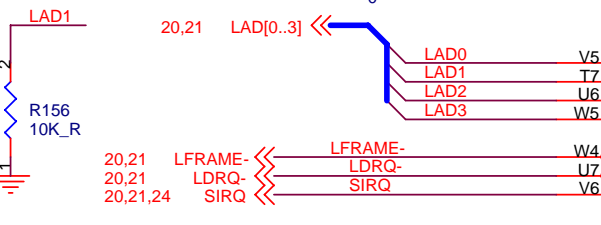
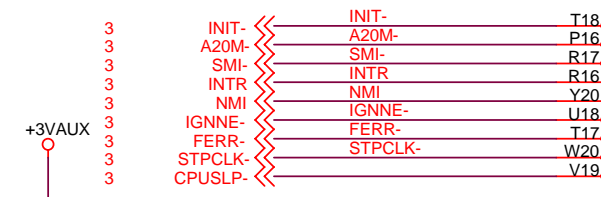

ECS CORP. (G733G M/B)			
Title	963(MISC)		
Size	Document Number	Rev	
Custom	G733G-1-3-01	4.0	
Date:	Wednesday, January 12, 2005	Sheet	10 of 39

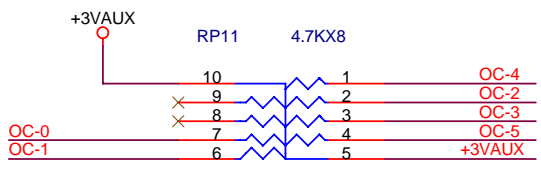

They don't need to be placed near the SiS963

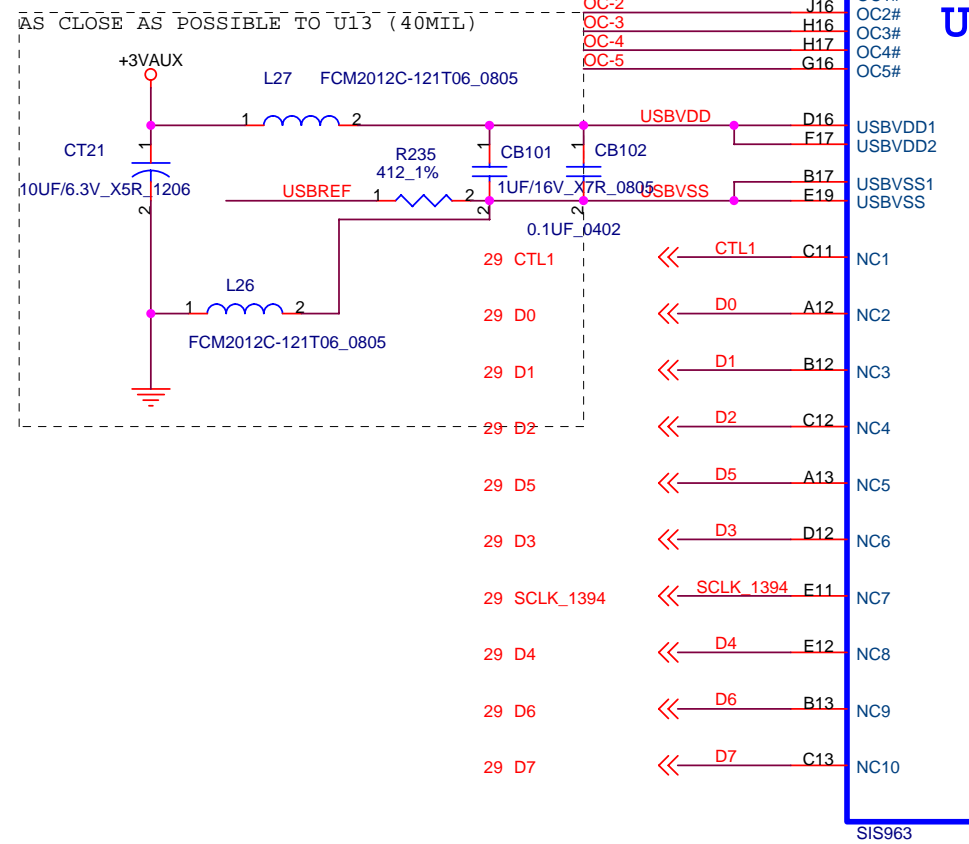
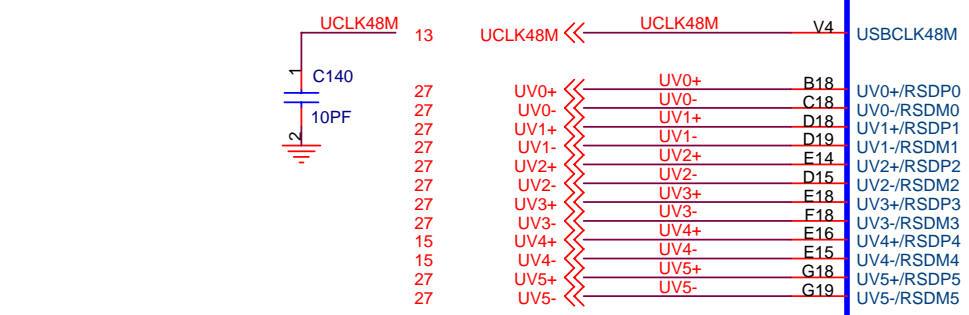
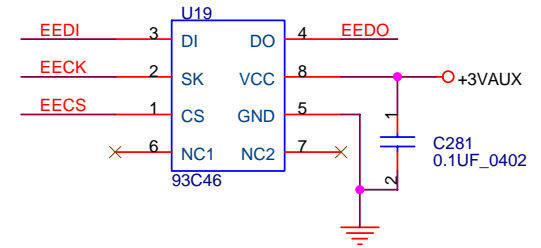
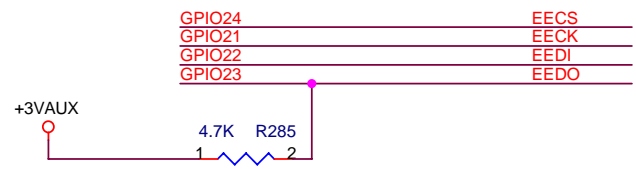

USB

963A-3

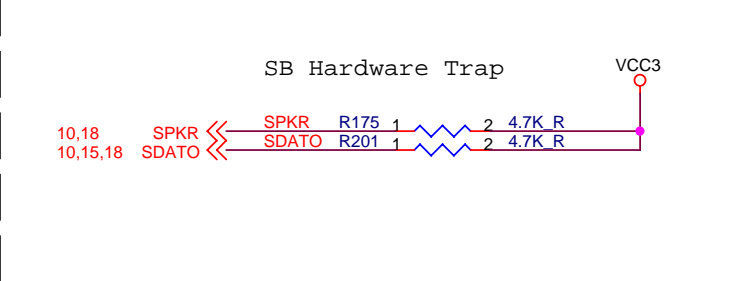
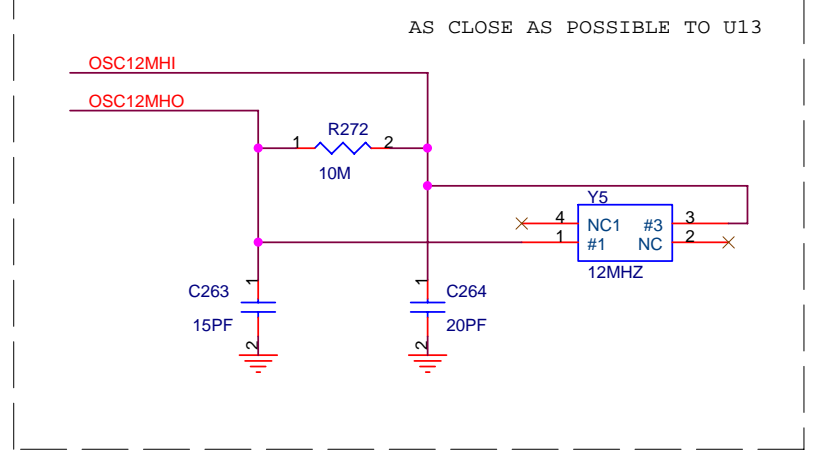
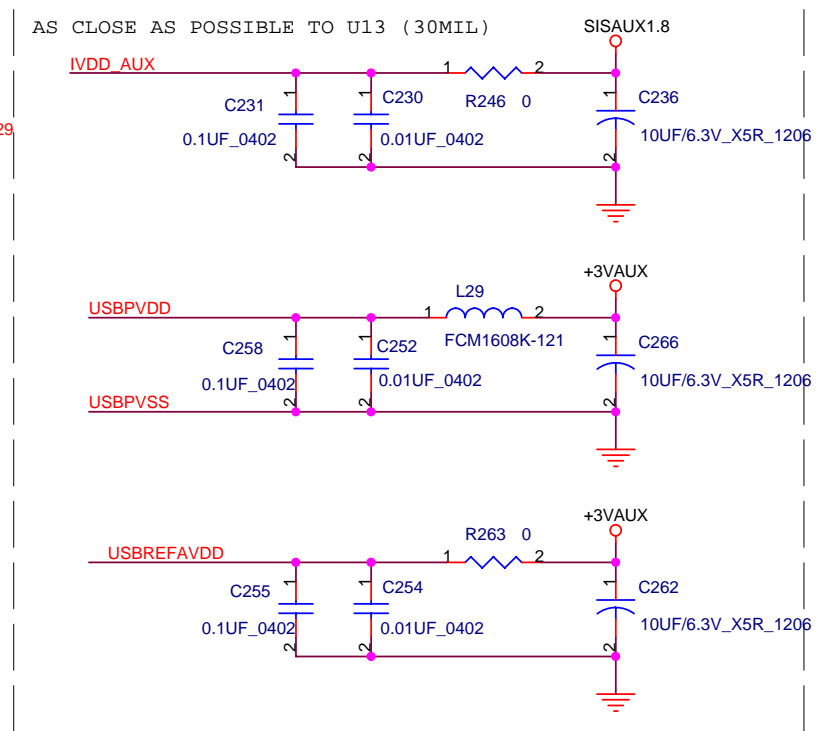
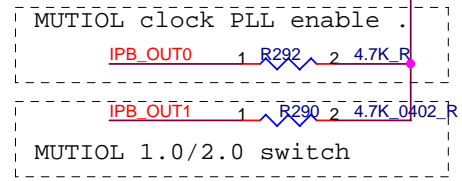
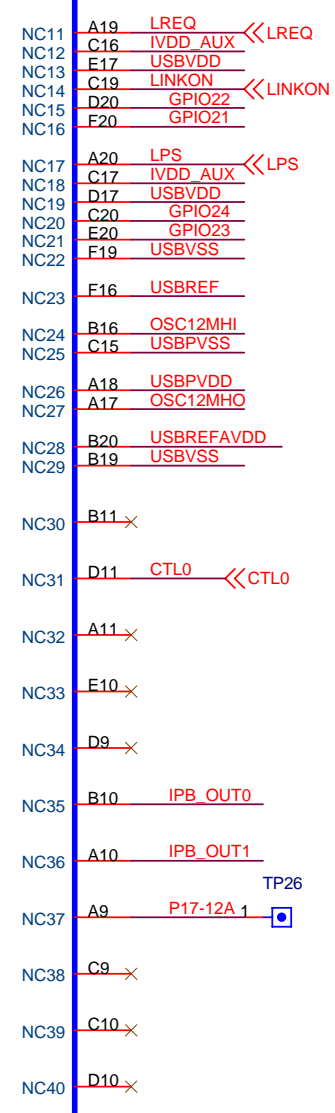
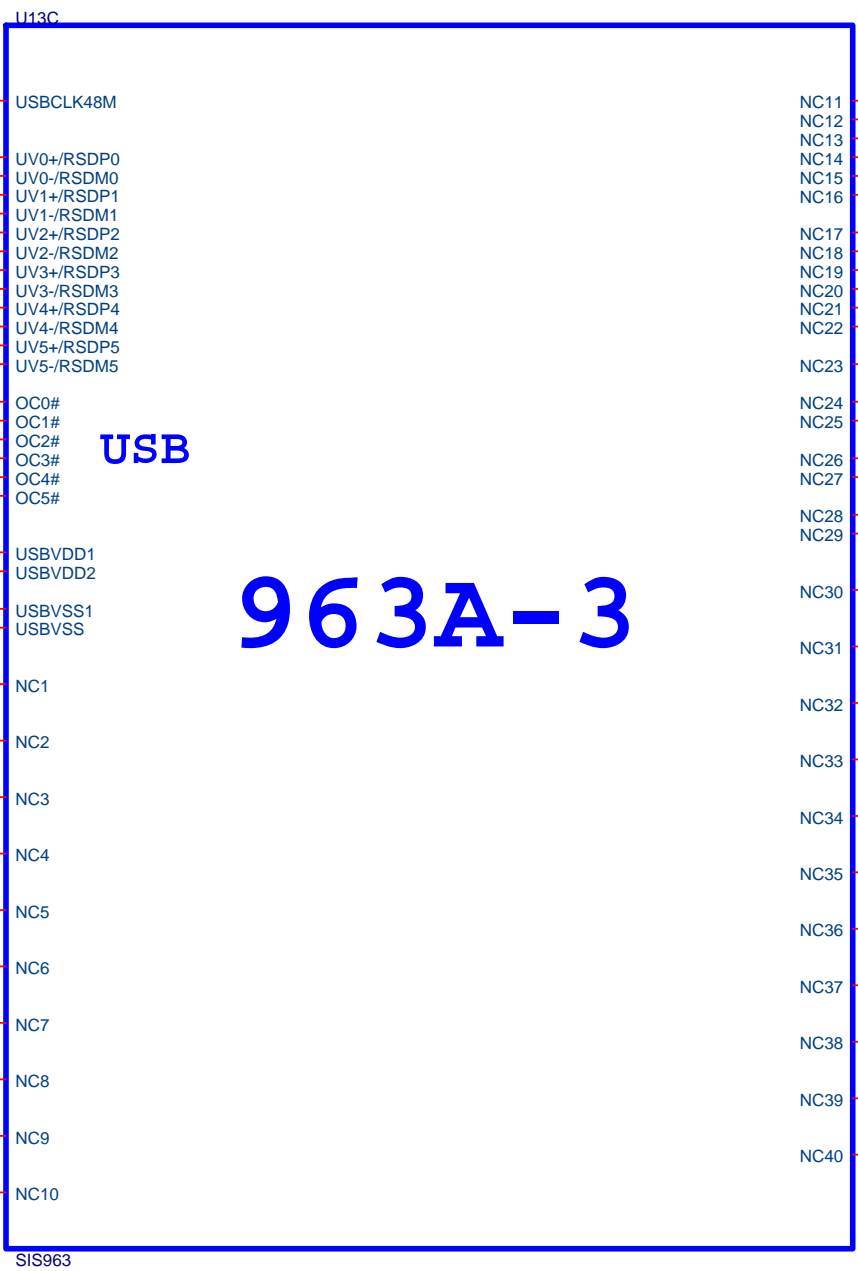

	0	1	Default
SPKR(LPC addr mapping)	disable	enable	0
SDATO(PCICLK PLL)	enable	disable	0
OC2-(SB debug mode)	enable	disable	1
OC5-(Trap mode)	PCI AD	ROM	1

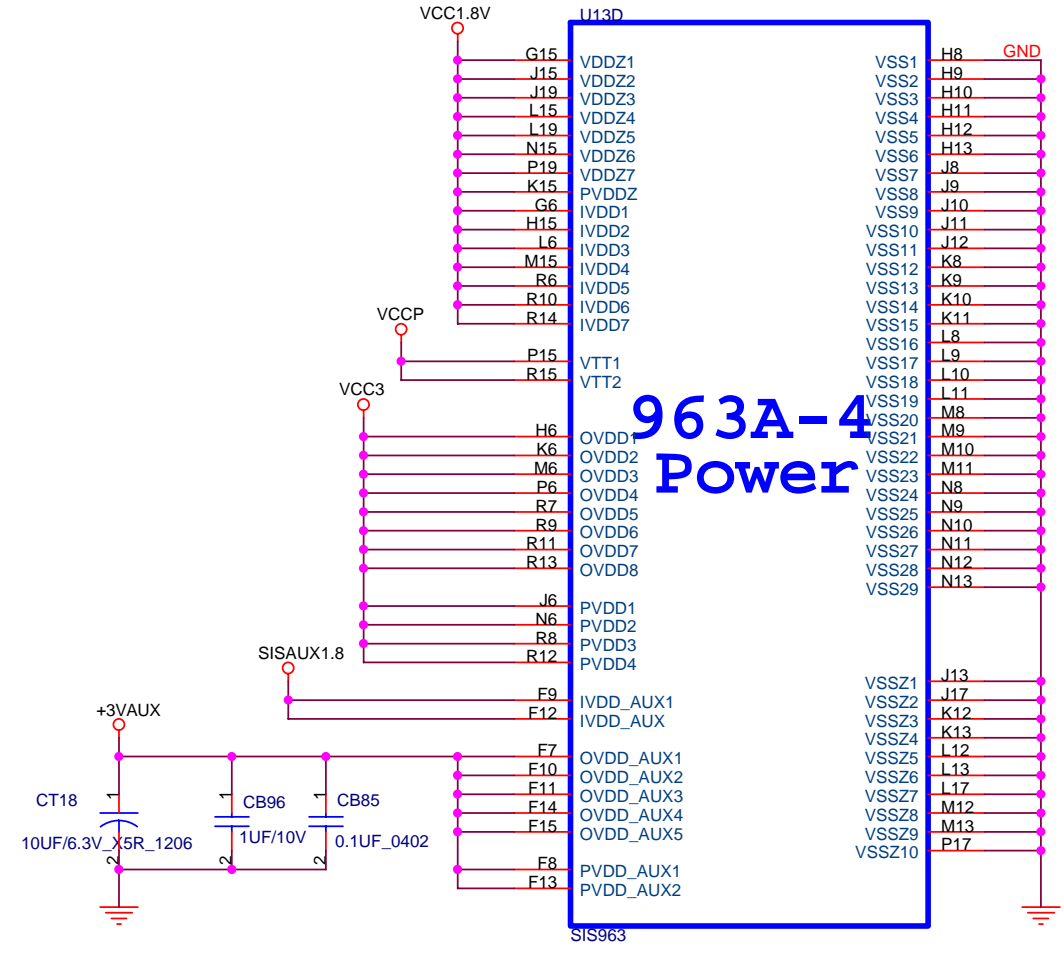
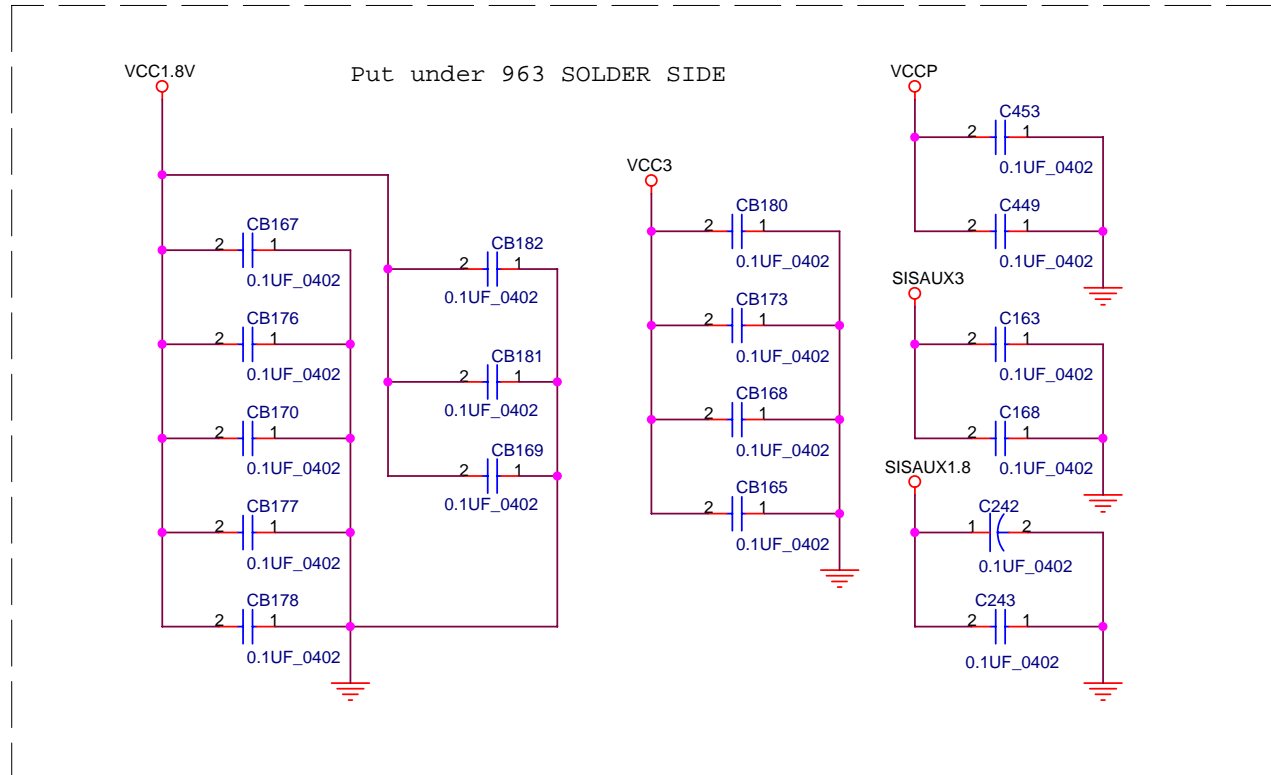
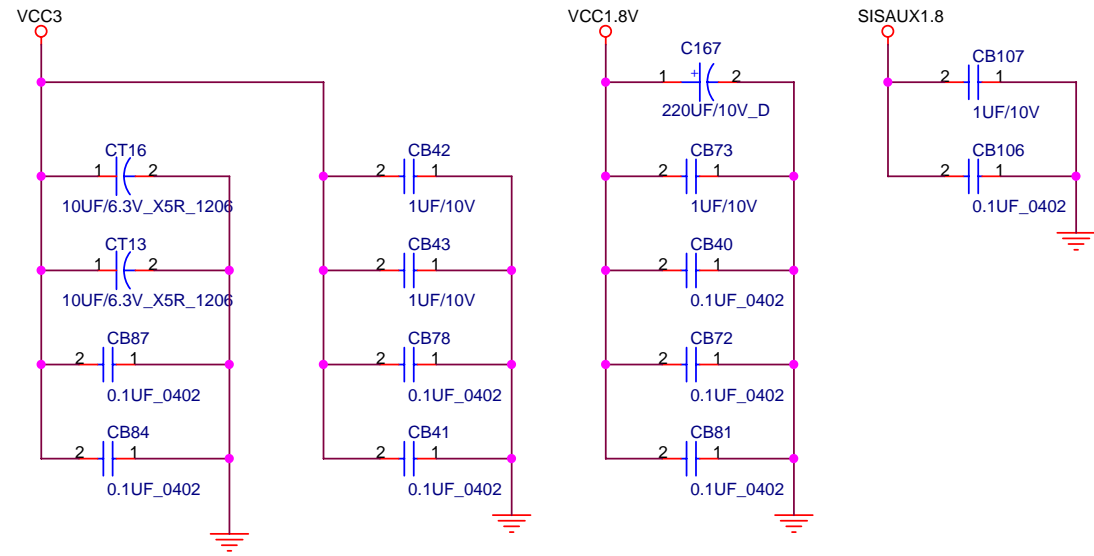

ECS CORP. (G733G M/B)			
Title	963(POWER)		
Size	Document Number	Rev	
Custom	G733G-1-3-01	4.0	
Date:	Wednesday, January 12, 2005	Sheet	12 of 39

Main Clock Generator

(3 OPTIONS)
 1: (ICS)
 2: (Cypress)
 3: (Hitachi)

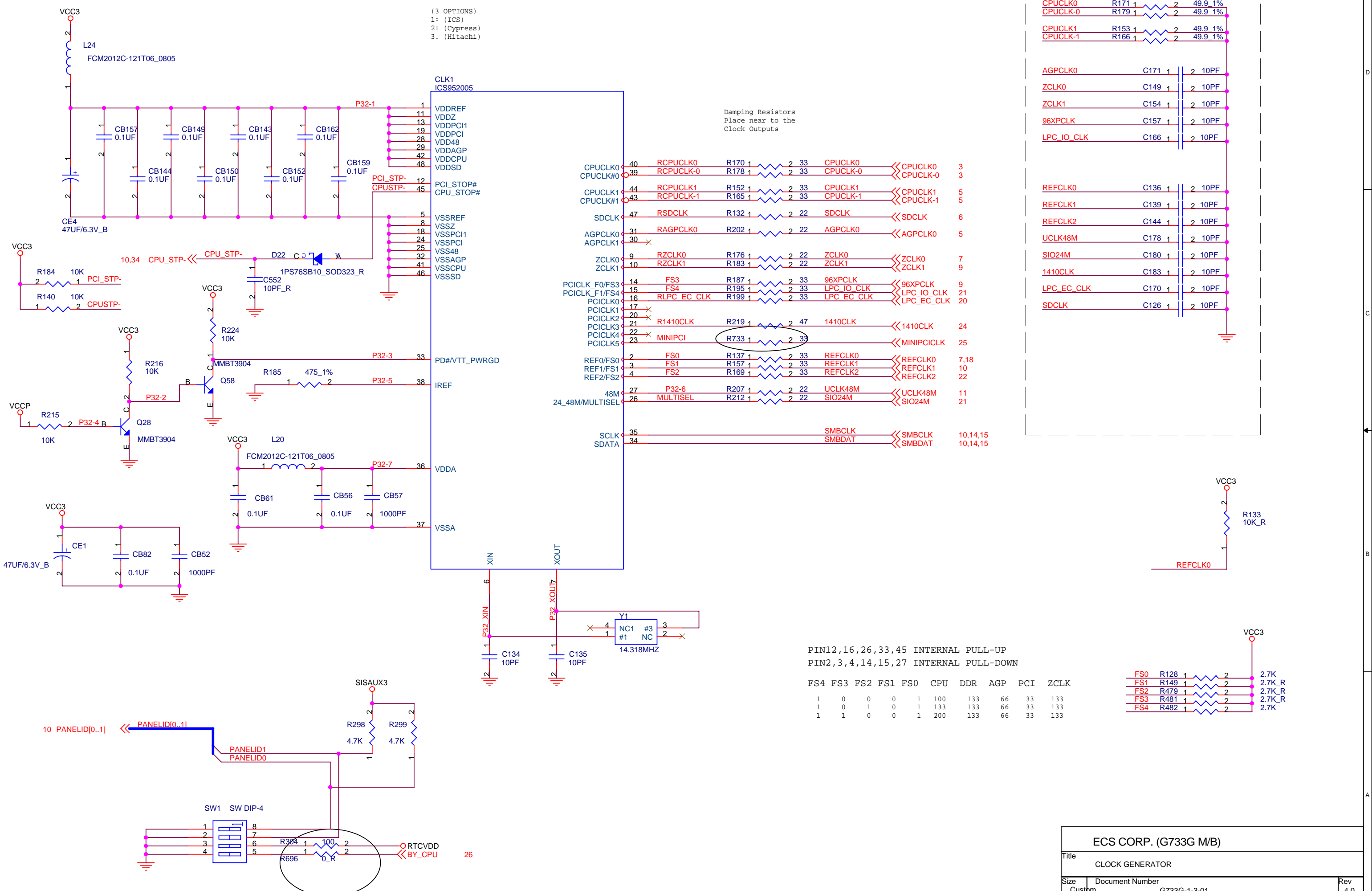

By-Pass Capacitors
Place near to the Clock Outputs

CPUCLK0	R171	1	2	49.9	1%
CPUCLK-0	R179	1	2	49.9	1%
CPUCLK1	R153	1	2	49.9	1%
CPUCLK-1	R166	1	2	49.9	1%
AGPCLK0	C171	1	2	10PF	
ZCLK0	C149	1	2	10PF	
ZCLK1	C154	1	2	10PF	
96XPCLK	C157	1	2	10PF	
LPC_IO_CLK	C166	1	2	10PF	
REFCLK0	C136	1	2	10PF	
REFCLK1	C139	1	2	10PF	
REFCLK2	C144	1	2	10PF	
UCLK48M	C178	1	2	10PF	
SIO24M	C180	1	2	10PF	
1410CLK	C183	1	2	10PF	
LPC_EC_CLK	C170	1	2	10PF	
SDCLK	C126	1	2	10PF	

Damping Resistors
Place near to the Clock Outputs

PIN12,16,26,33,45 INTERNAL PULL-UP
 PIN2,3,4,14,15,27 INTERNAL PULL-DOWN

FS4	FS3	FS2	FS1	FS0	CPU	DDR	AGP	PCI	ZCLK
1	0	0	0	1	100	133	66	33	133
1	0	1	0	1	133	133	66	33	133
1	1	0	0	1	200	133	66	33	133

FS0	R128	1	2	2.7K
FS1	R149	1	2	2.7K_R
FS2	R479	1	2	2.7K_R
FS3	R481	1	2	2.7K_R
FS4	R482	1	2	2.7K

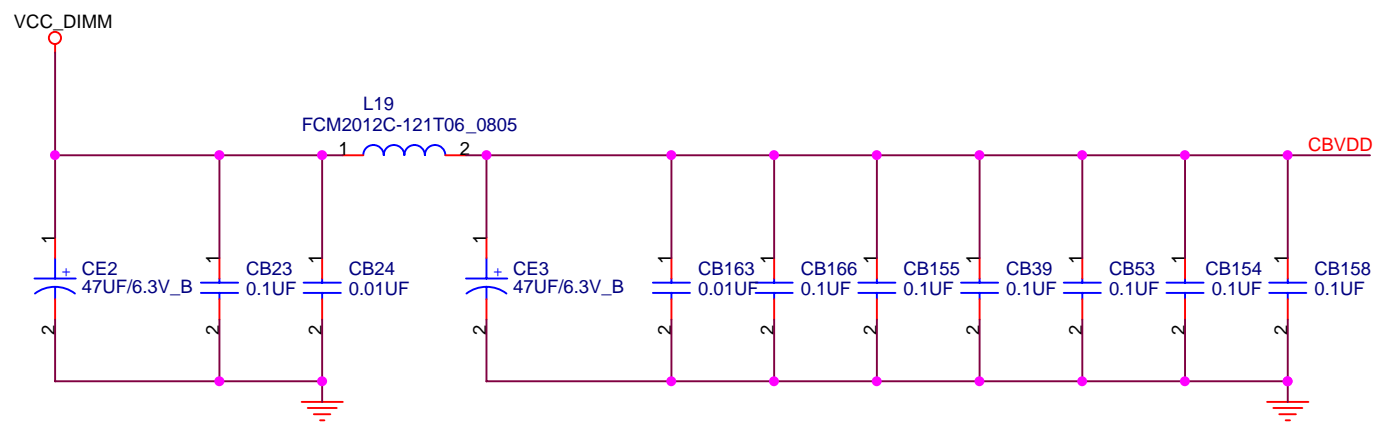

Clock Buffer (DDR)

(OPTIONS)
1: (ICS-93722)

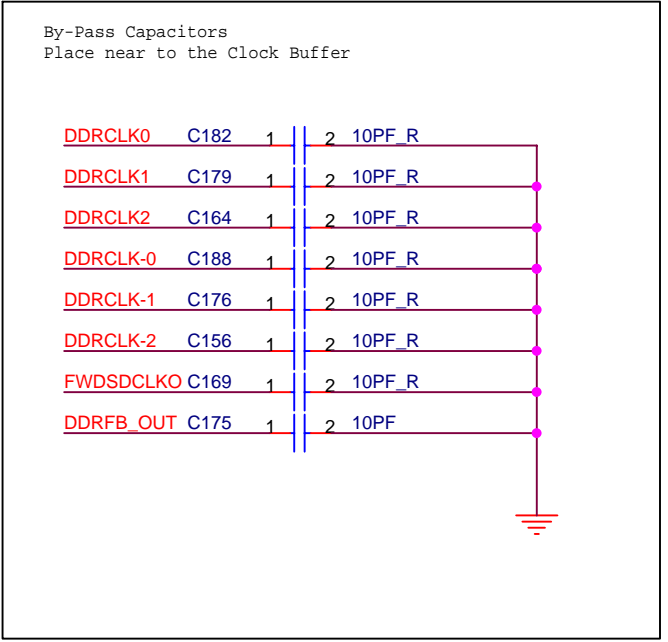
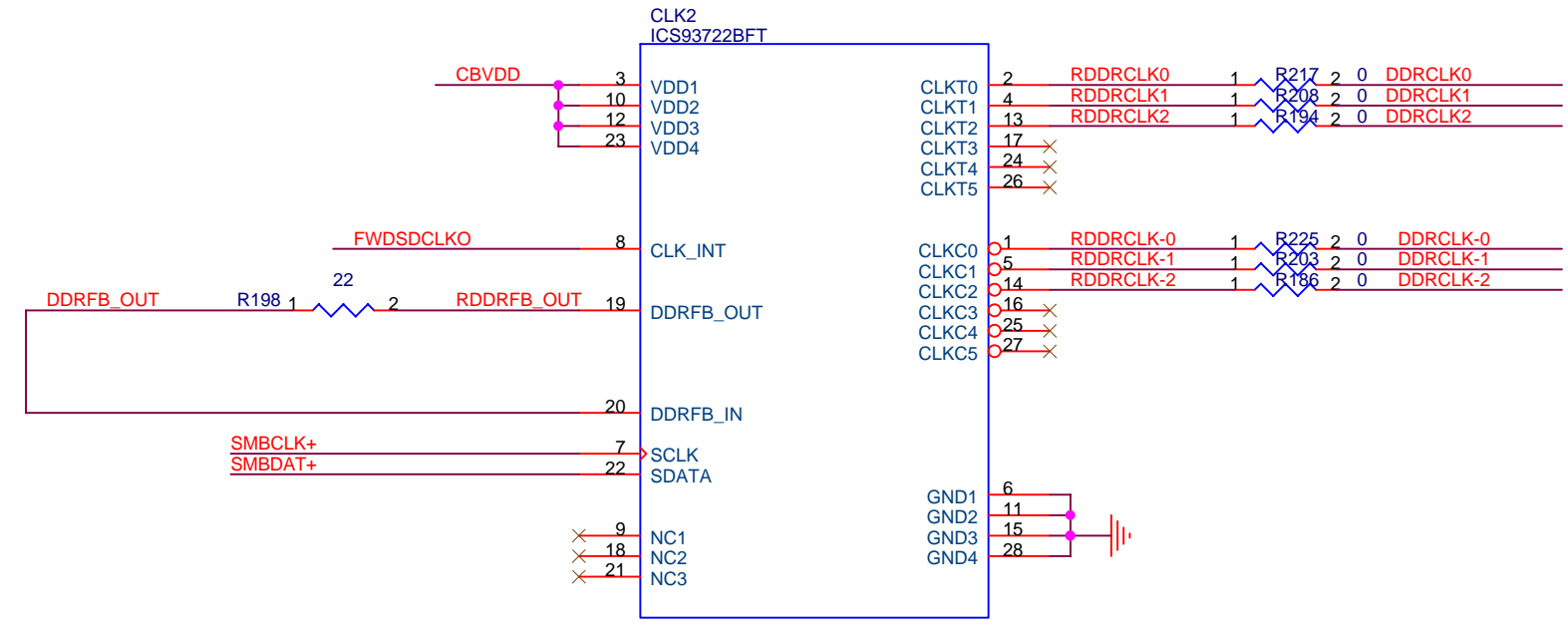
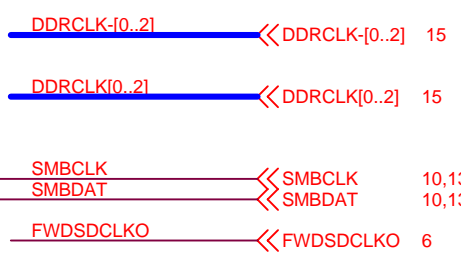

ECS CORP. (G733G M/B)		
Title CLOCK BUFFER FOR DDR		
Size B	Document Number G733G-1-3-01	Rev 4.0
Date: Wednesday, January 12, 2005	Sheet 14	of 39

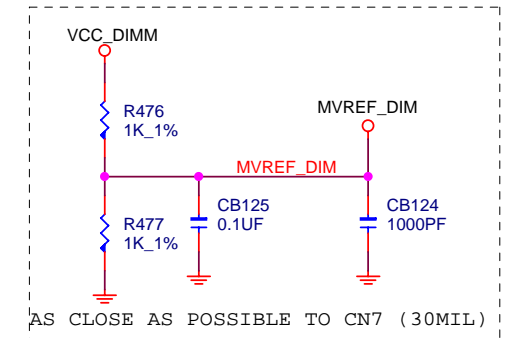
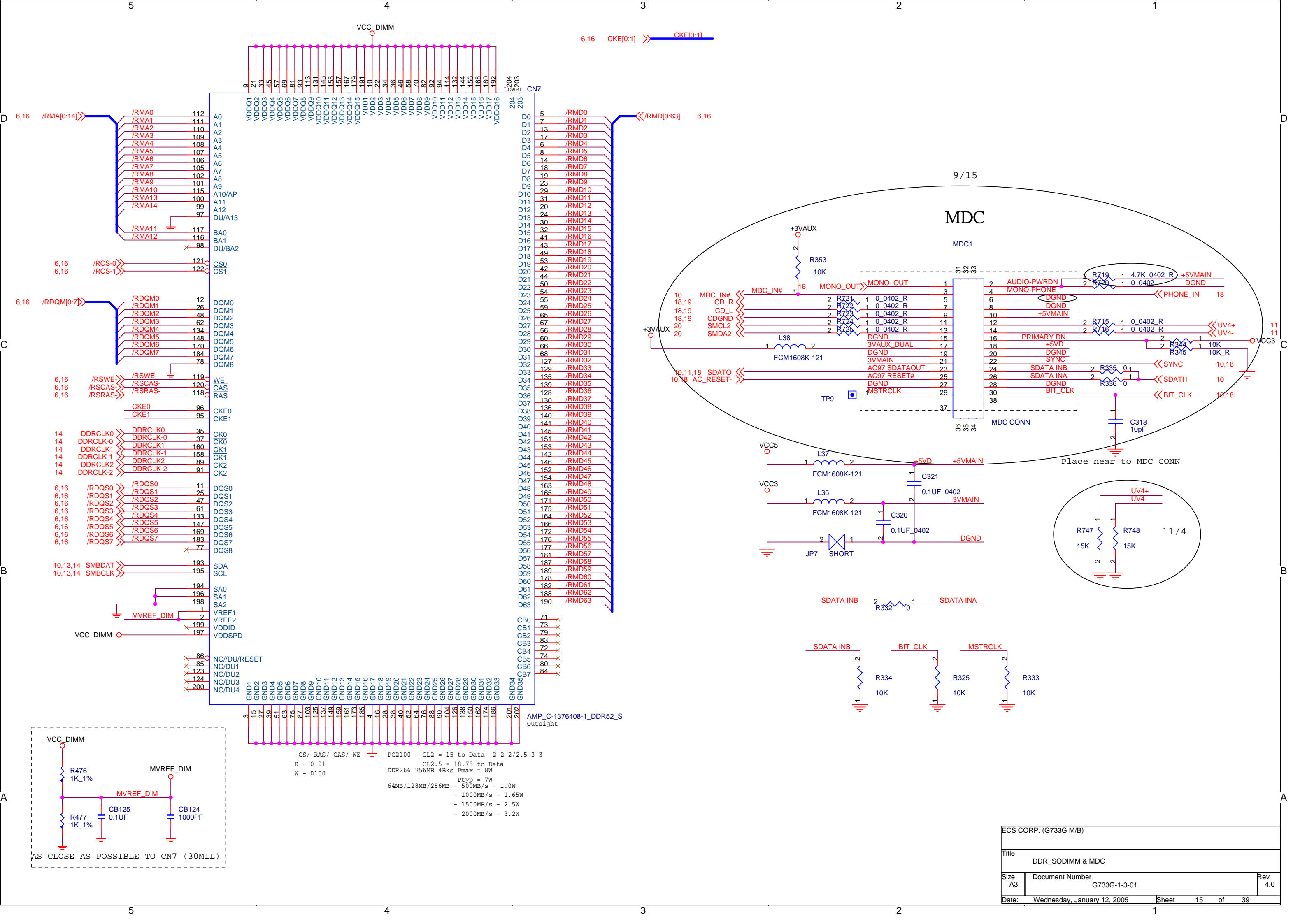

PC2100 - CL2 = 15 to Data 2-2-2/2.5-3-3
 R - 0101 CL2.5 = 18.75 to Data
 W - 0100 DDR266 256MB 4Bks Pmax = 8W

Ptyp = 7W
 - 500MB/s - 1.0W
 - 1000MB/s - 1.65W
 - 1500MB/s - 2.5W
 - 2000MB/s - 3.2W

ECS CORP. (G733G M/B)		
Title DDR_SODIMM & MDC		
Size A3	Document Number G733G-1-3-01	Rev 4.0
Date: Wednesday, January 12, 2005	Sheet 15	of 39

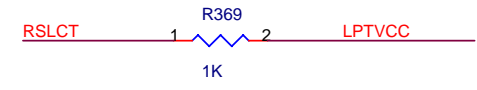
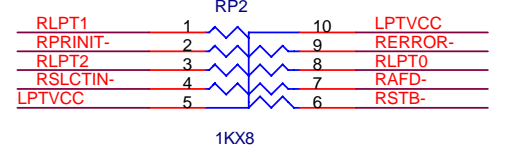
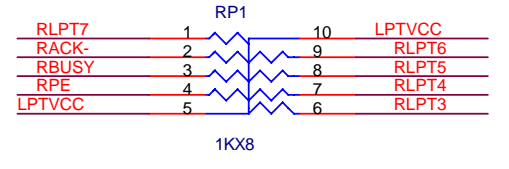
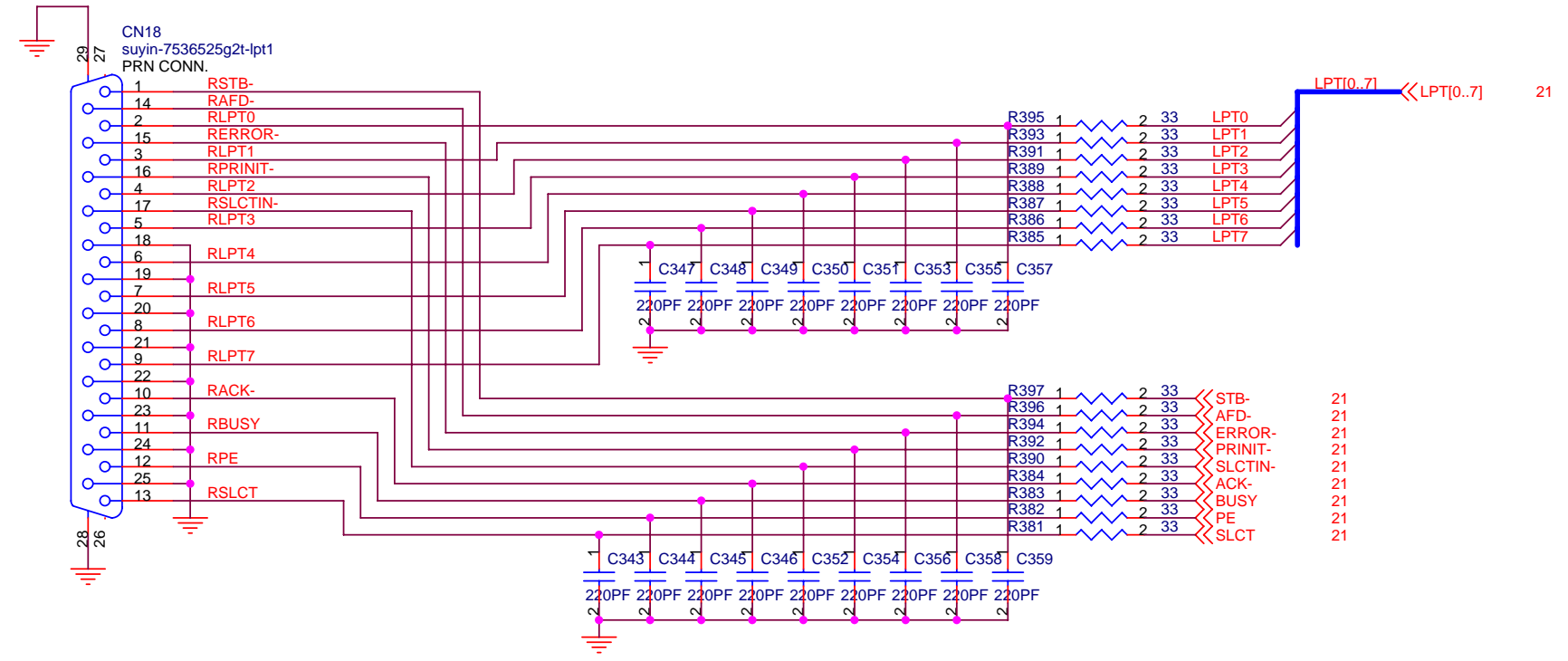
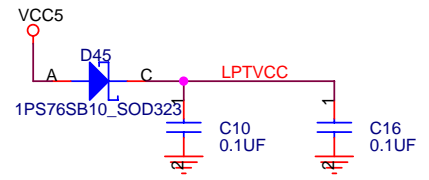
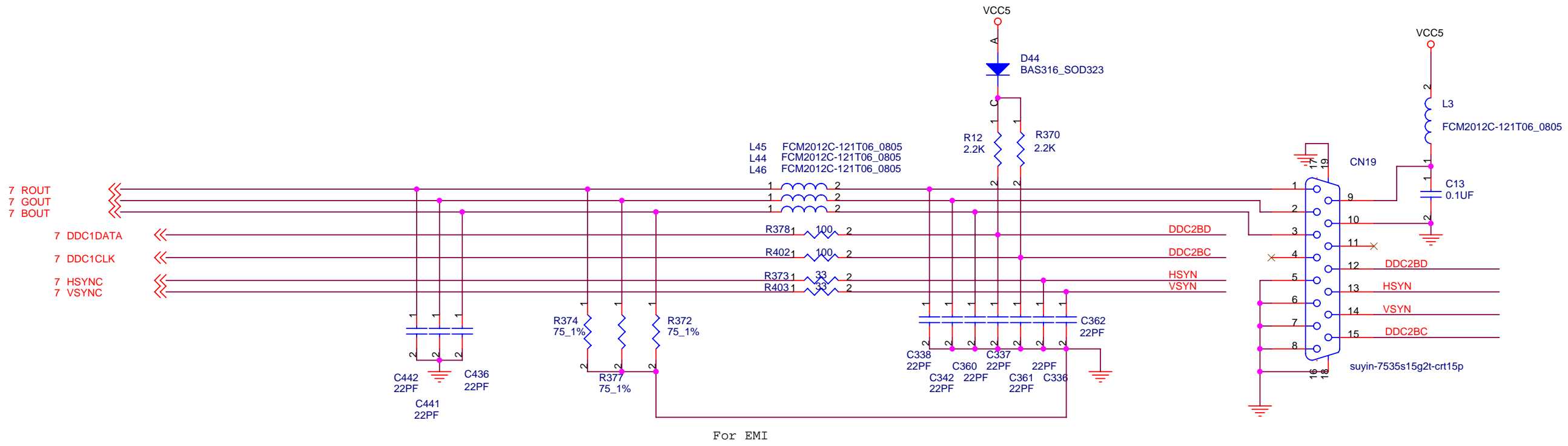

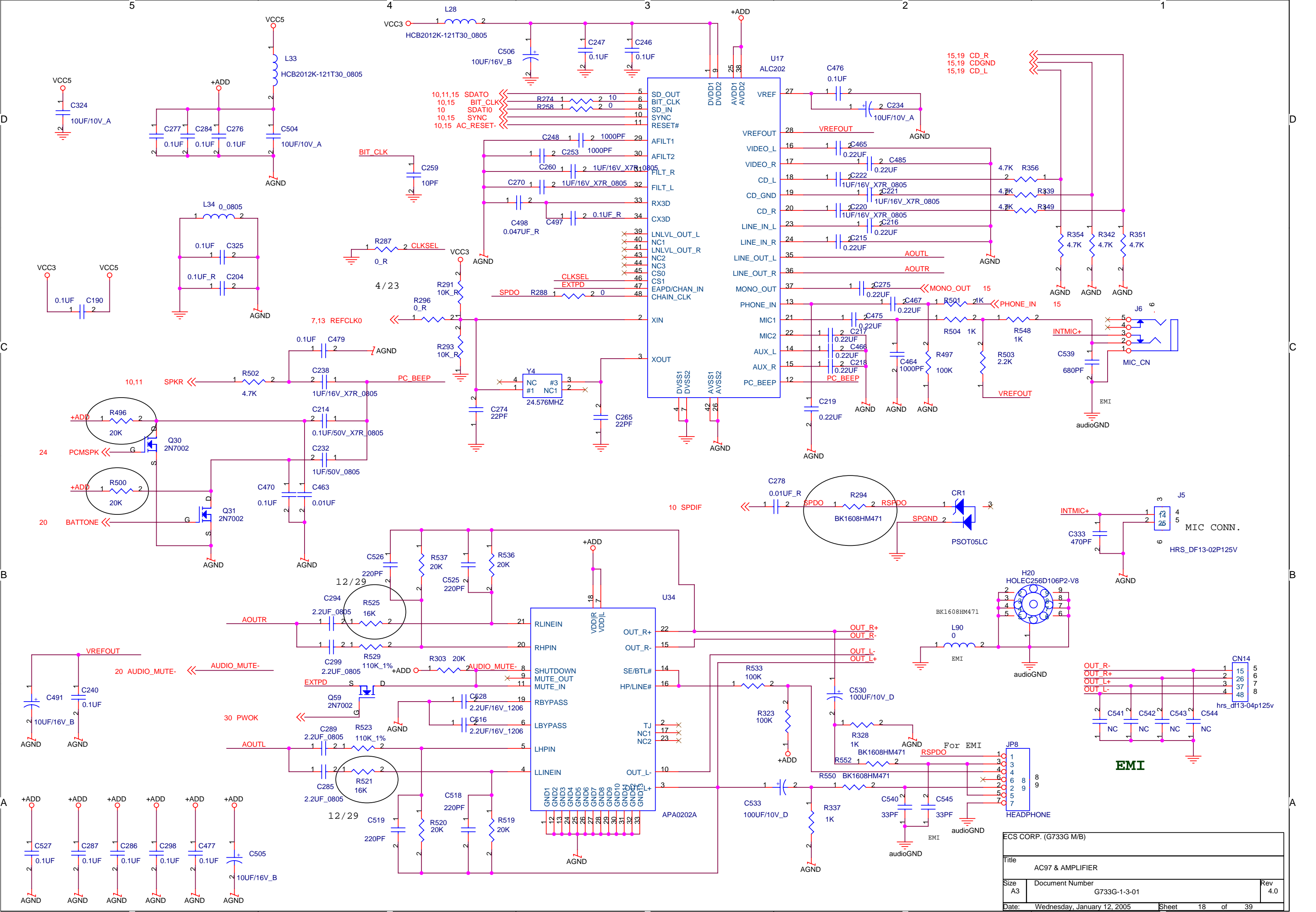

ECS CORP. (G733G M/B)		
Title AC97 & AMPLIFIER		
Size A3	Document Number G733G-1-3-01	Rev 4.0
Date: Wednesday, January 12, 2005	Sheet 18	of 39

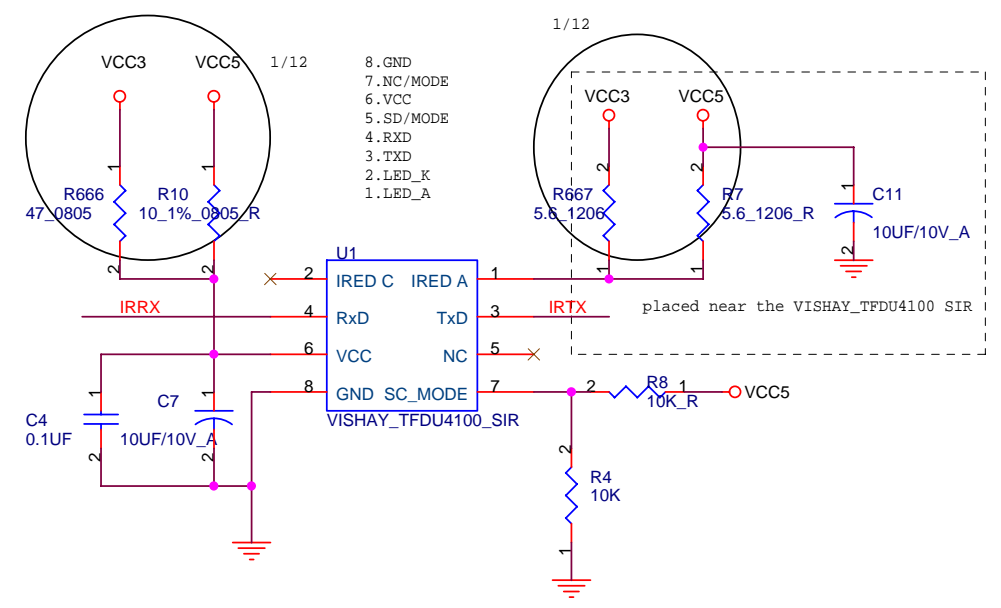
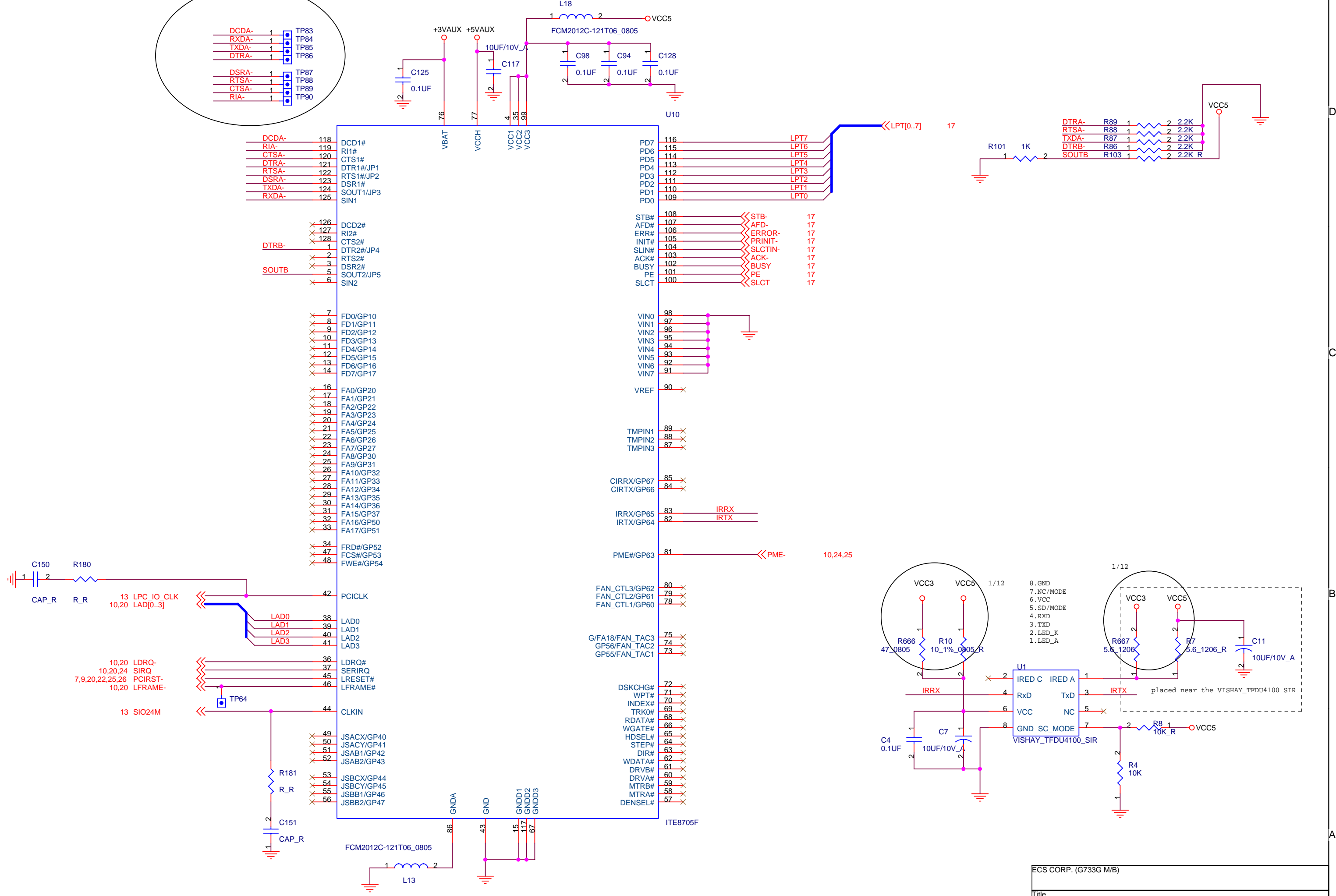
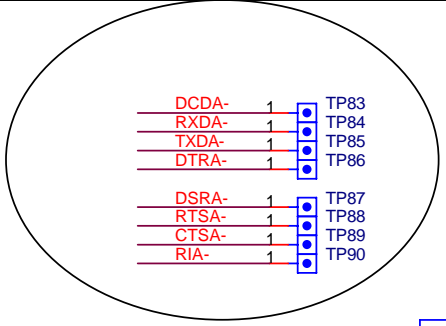

ECS CORP. (G733G M/B)		
Title ITE8705F LPC SUPER IO		
Size A3	Document Number G733G-1-3-01	Rev 4.0
Date: Wednesday, January 12, 2005	Sheet 21	of 39

CHOOSE CLOCK SOURCE		
CLOCK SOURCE	CLOCK GEN	CRYSTAL
R466	10	NC
R467	NC	10

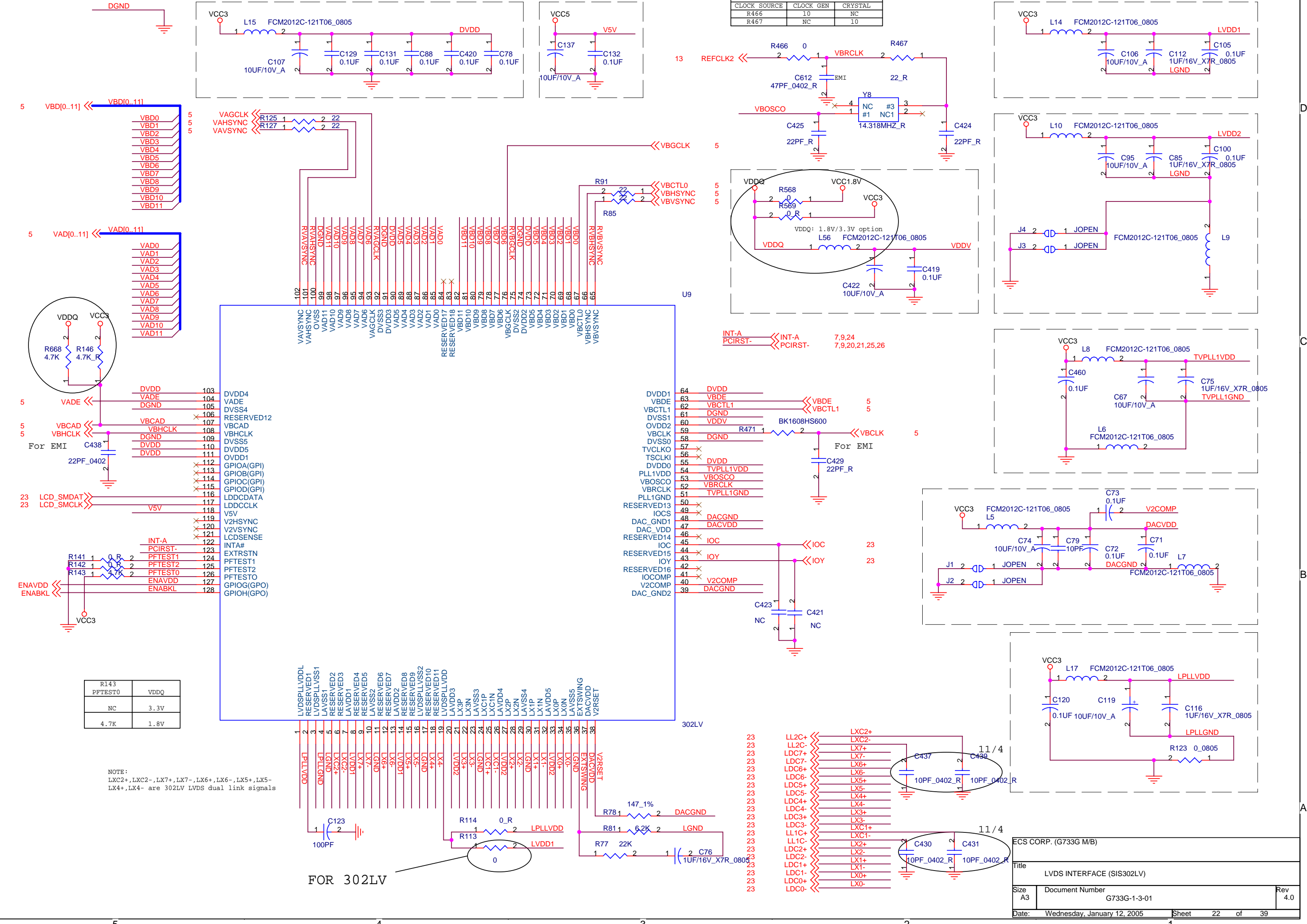

R143	VDDQ
NC	3.3V
4.7K	1.8V

NOTE:
LXC2+,LXC2-,LX7+,LX7-,LX6+,LX6-,LX5+,LX5-,LX4+,LX4- are 302LV LVDS dual link signals

FOR 302LV

ECS CORP. (G733G M/B)		
Title LVDS INTERFACE (SIS302LV)		
Size A3	Document Number G733G-1-3-01	Rev 4.0
Date: Wednesday, January 12, 2005	Sheet 22	of 39

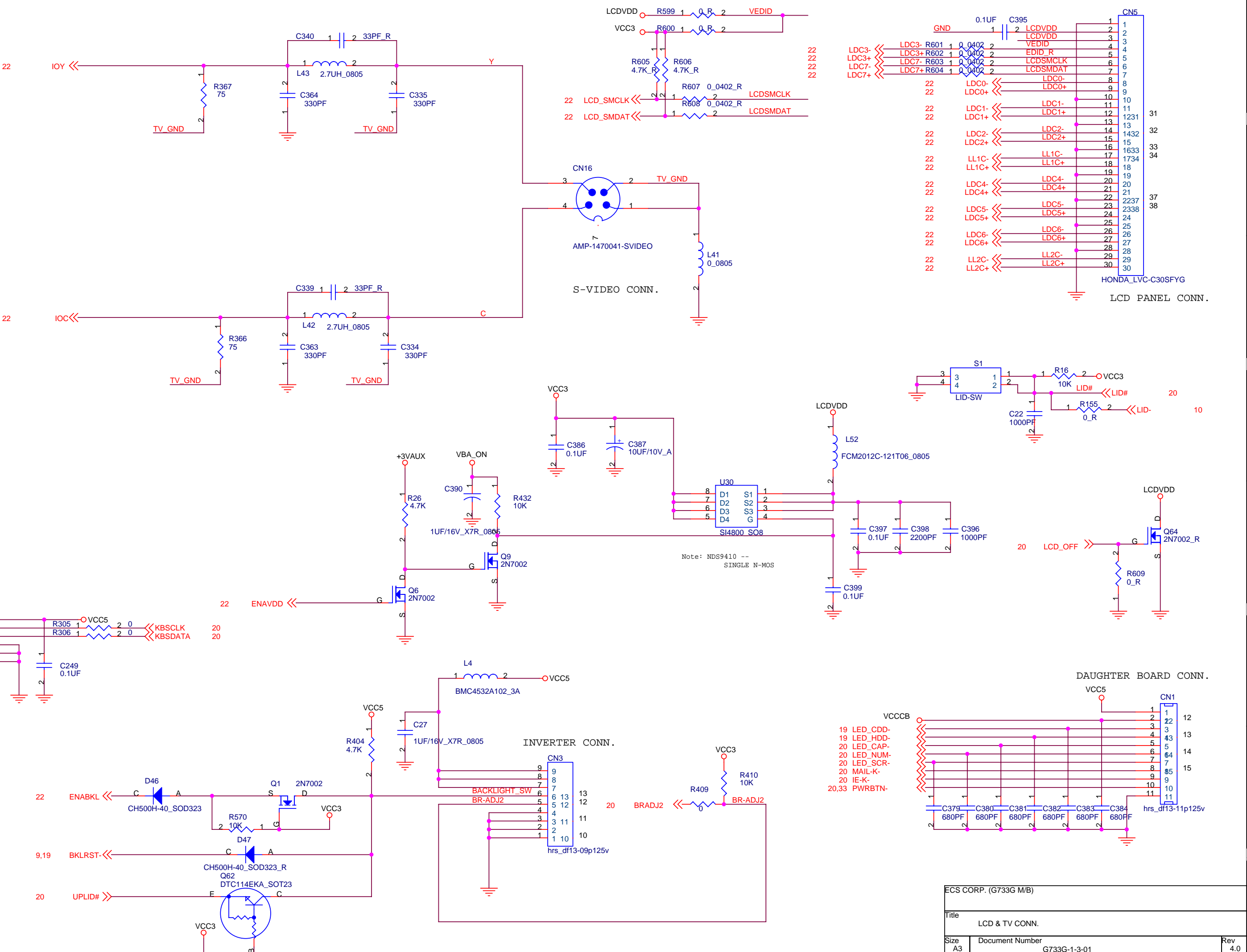

HONDA_LVC-C30SFYG
LCD PANEL CONN.

1	LDC3-	LDC3- R601	1	0_0402	2	LCDVDD	1
2	LDC3+	LDC3+ R602	1	0_0402	2	LCDVDD	2
3	LDC7-	LDC7- R603	1	0_0402	2	VEDID	3
4	LDC7+	LDC7+ R604	1	0_0402	2	EDID_R	4
5						LCDSMCLK	5
6						LCDSMDAT	6
7						LDC0-	7
8						LDC0+	8
9						LDC1-	9
10						LDC1+	10
11						LDC2-	11
12						LDC2+	12
13						LL1C-	13
14						LL1C+	14
15						LDC4-	15
16						LDC4+	16
17						LDC5-	17
18						LDC5+	18
19						LDC6-	19
20						LDC6+	20
21						LL2C-	21
22						LL2C+	22

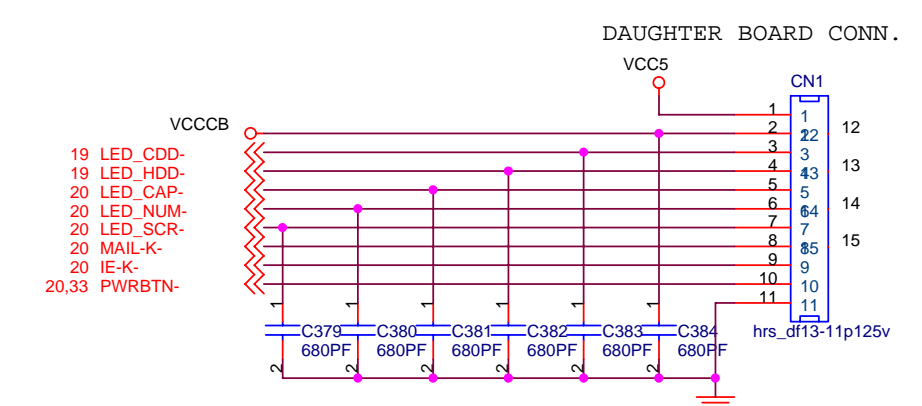
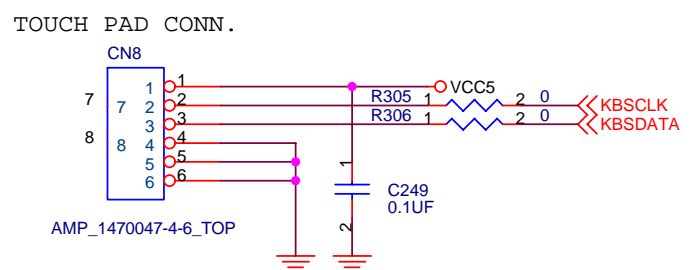
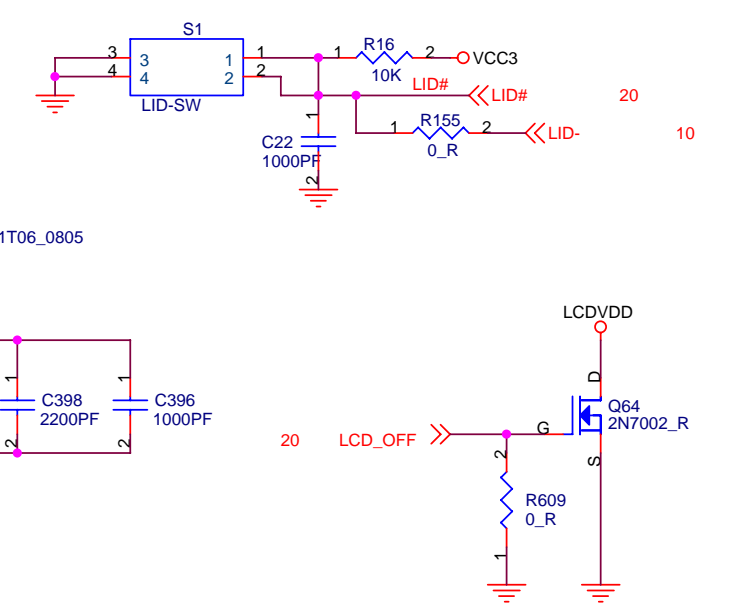

ECS CORP. (G733G M/B)

Title LCD & TV CONN.

Size A3

Document Number G733G-1-3-01

Date: Wednesday, January 12, 2005

Sheet 23 of 39

Rev 4.0

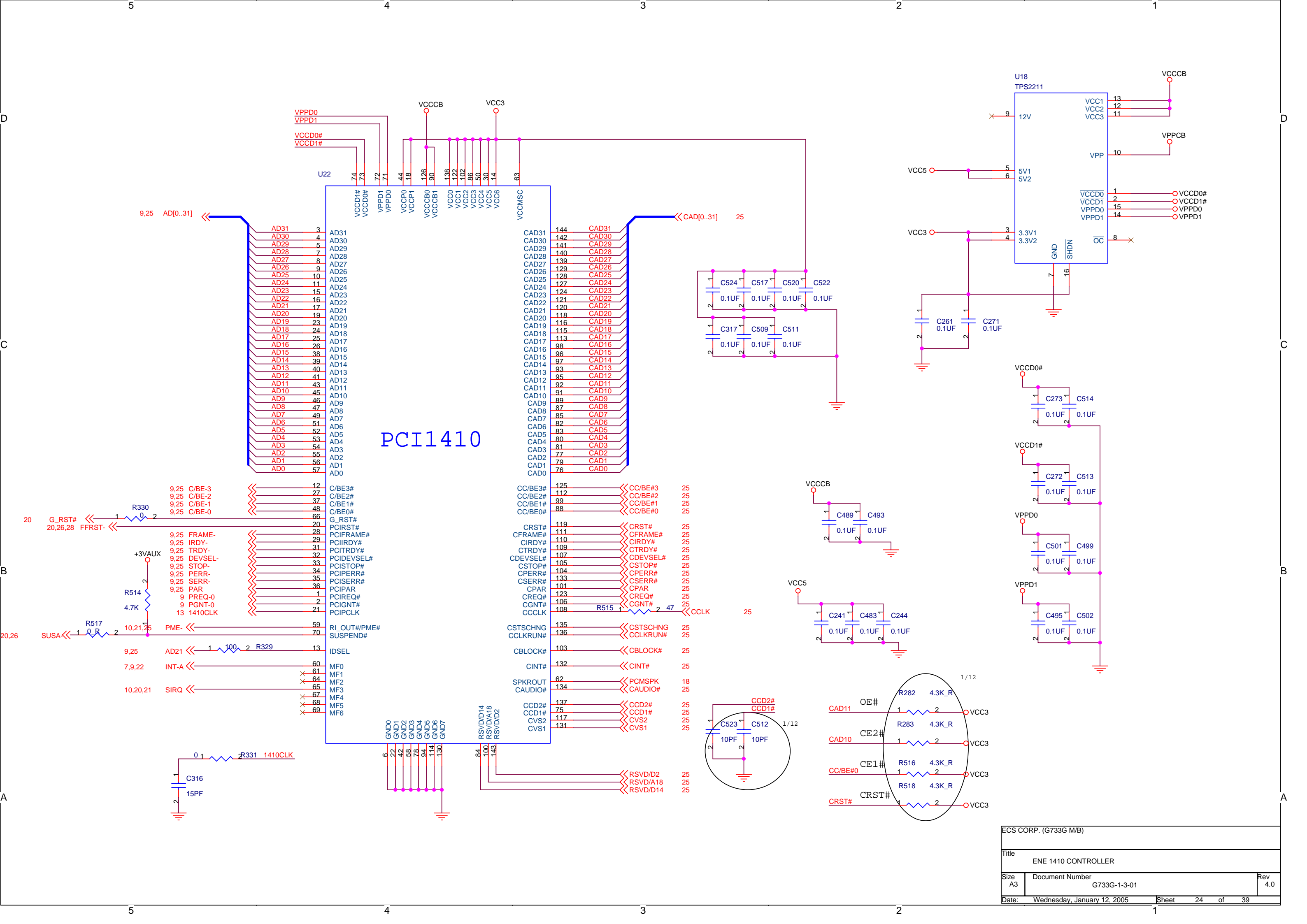

PCMCIA SLOT

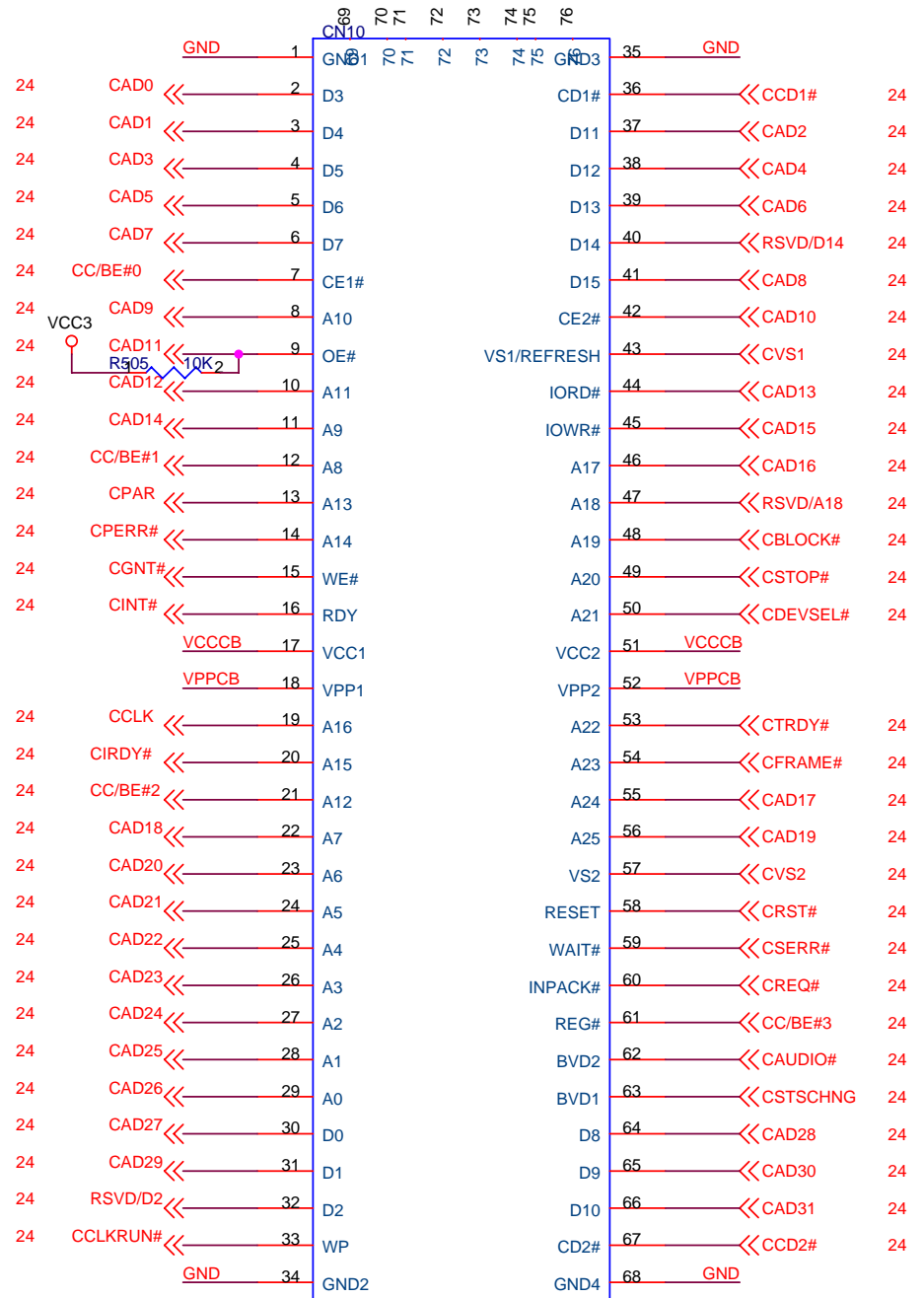

HONDA_ICMB-A68LMYG-AS3-R

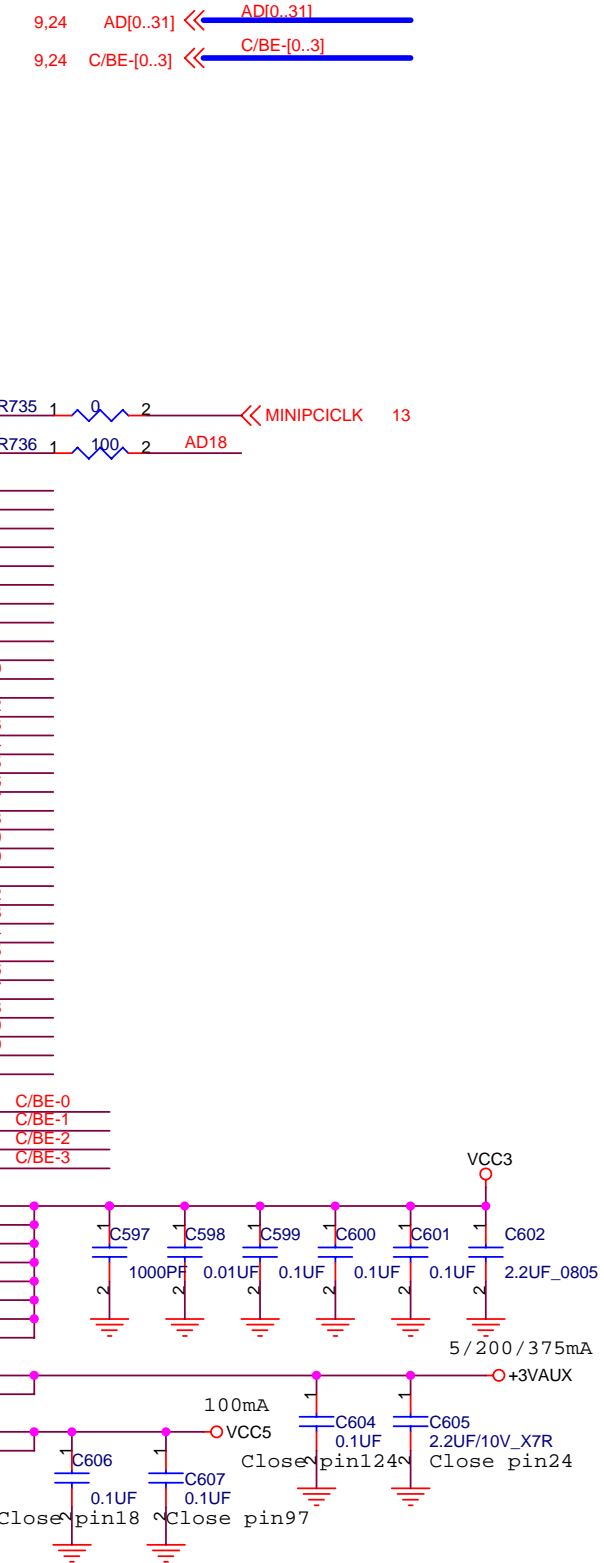
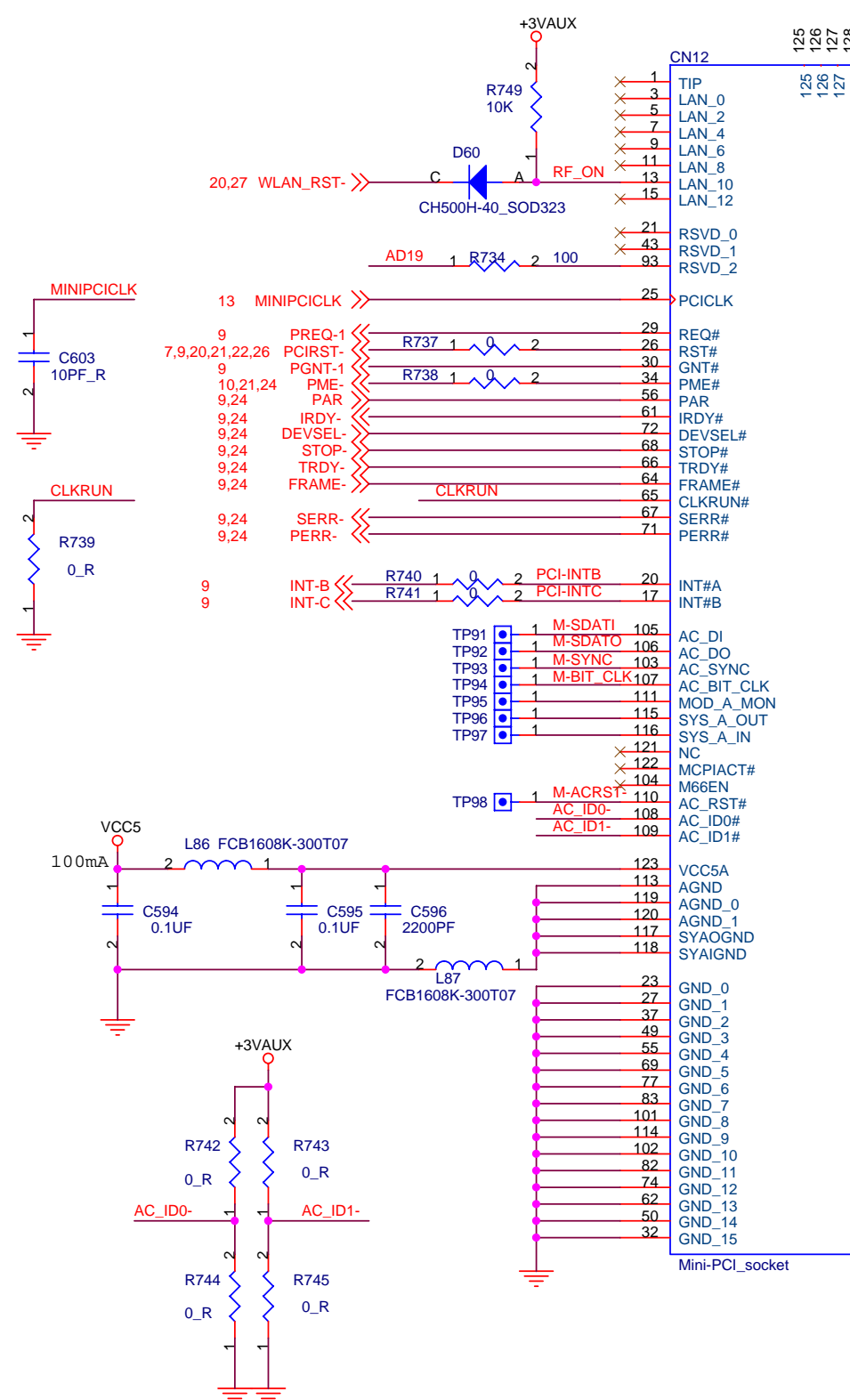
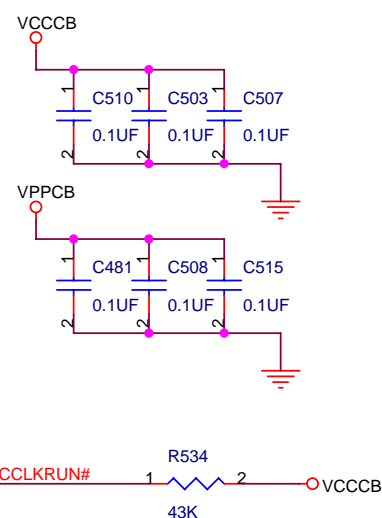

ECS CORP. (G733G M/B)		
Title PCMCIA & MINI-PCI CONN.		
Size A3	Document Number G733G-1-3-01	Rev 4.0
Date: Wednesday, January 12, 2005	Sheet 25	of 39

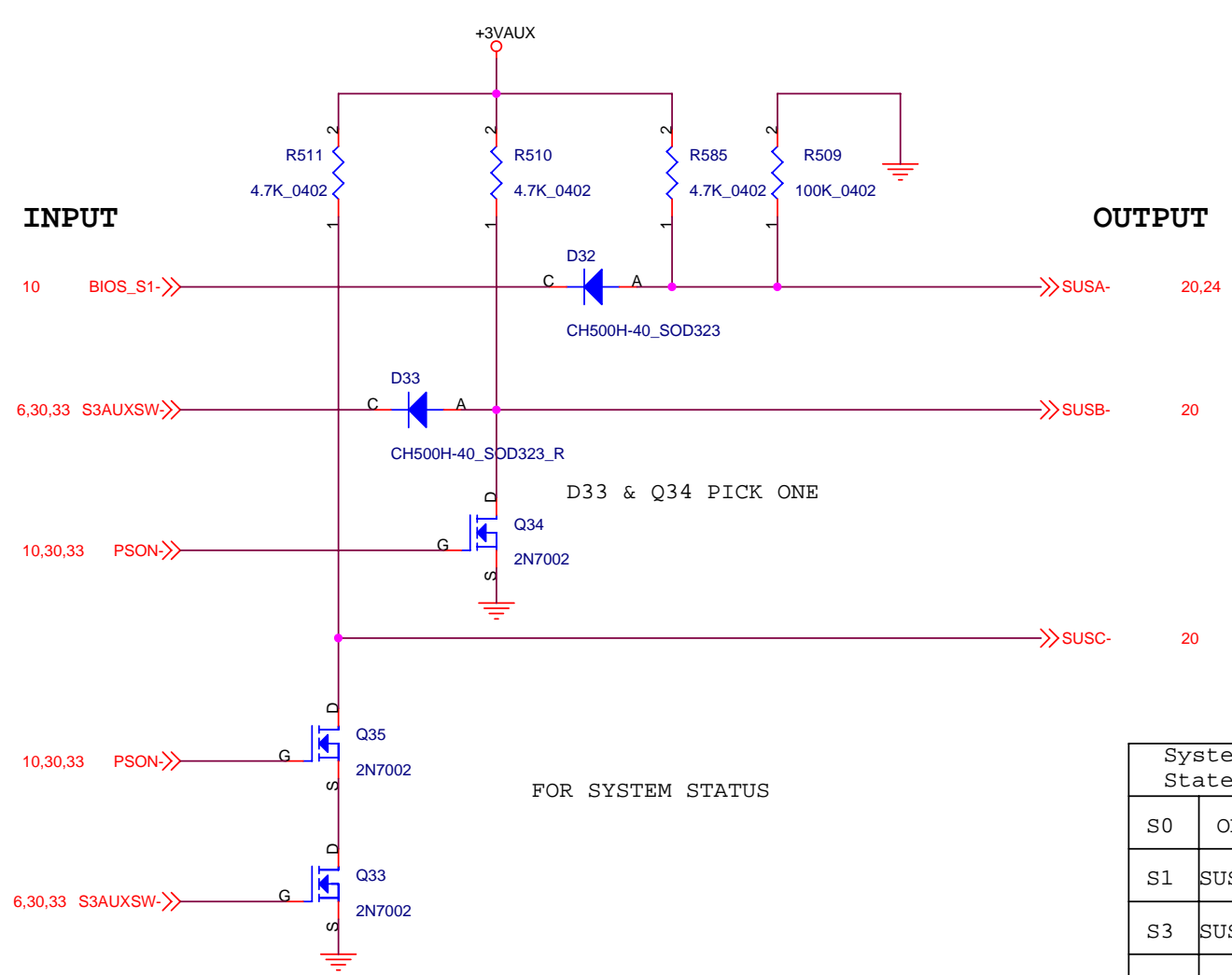
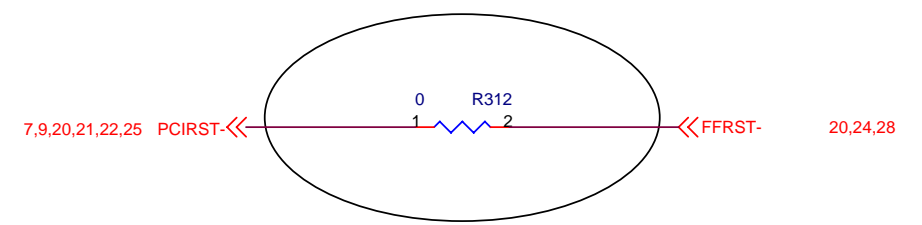
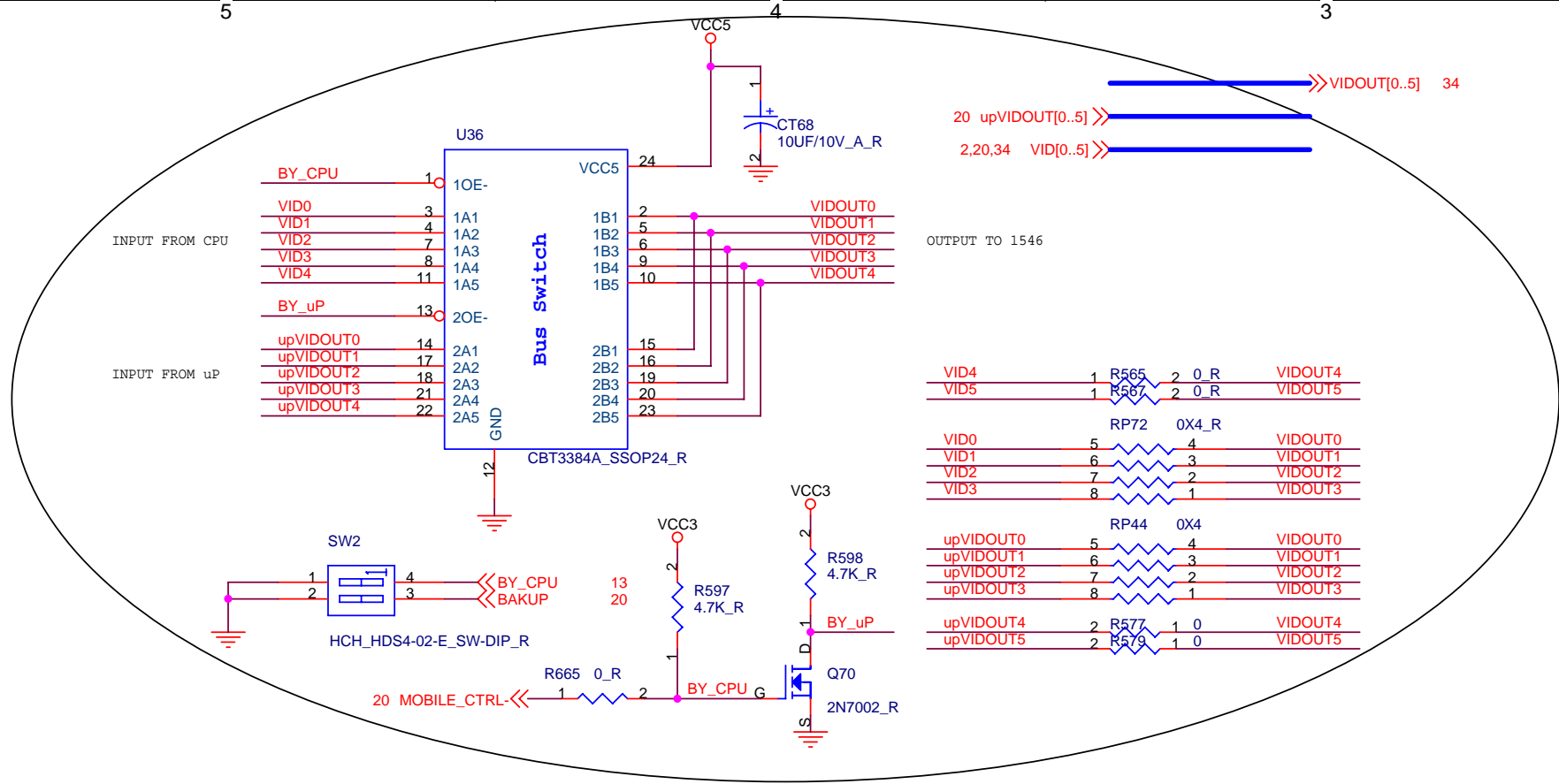

System State	BIOS_SI-	PSON-	S3AUXSW-	S4-
S0	ON	H	L	H
S1	SUSA#	L	L	H
S3	SUSB#	X	H	L
S4	SUSC#	X	H	L
S5	OFF	X	H	H

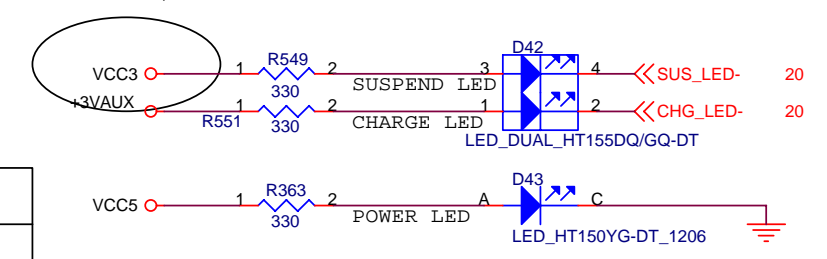
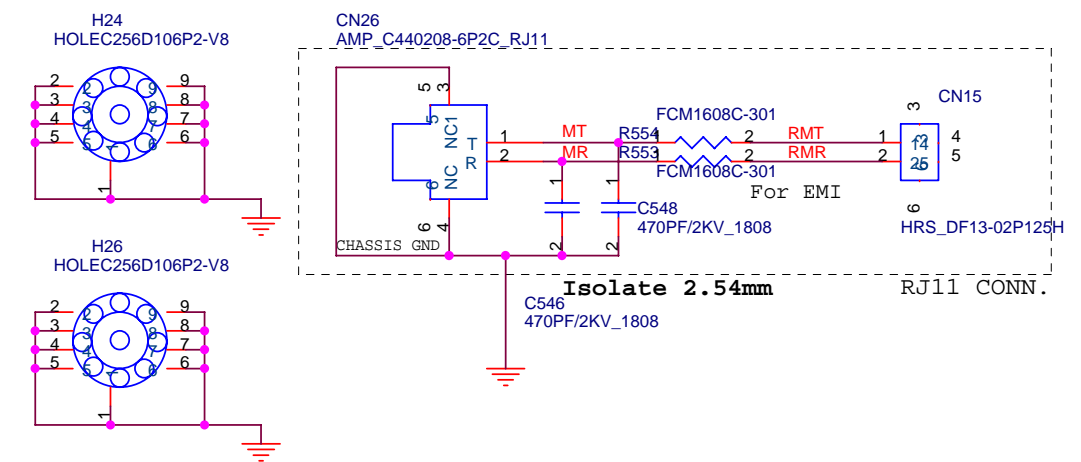

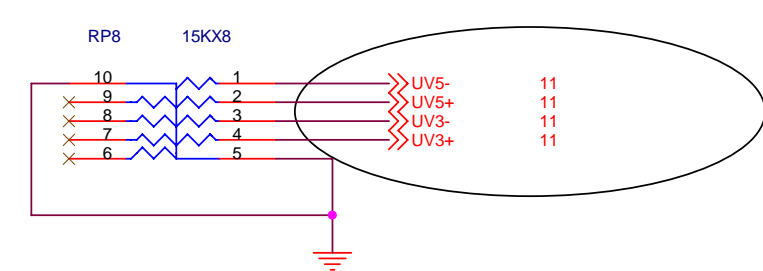
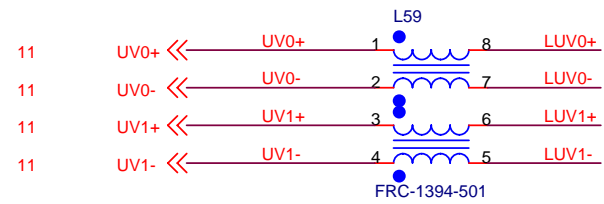
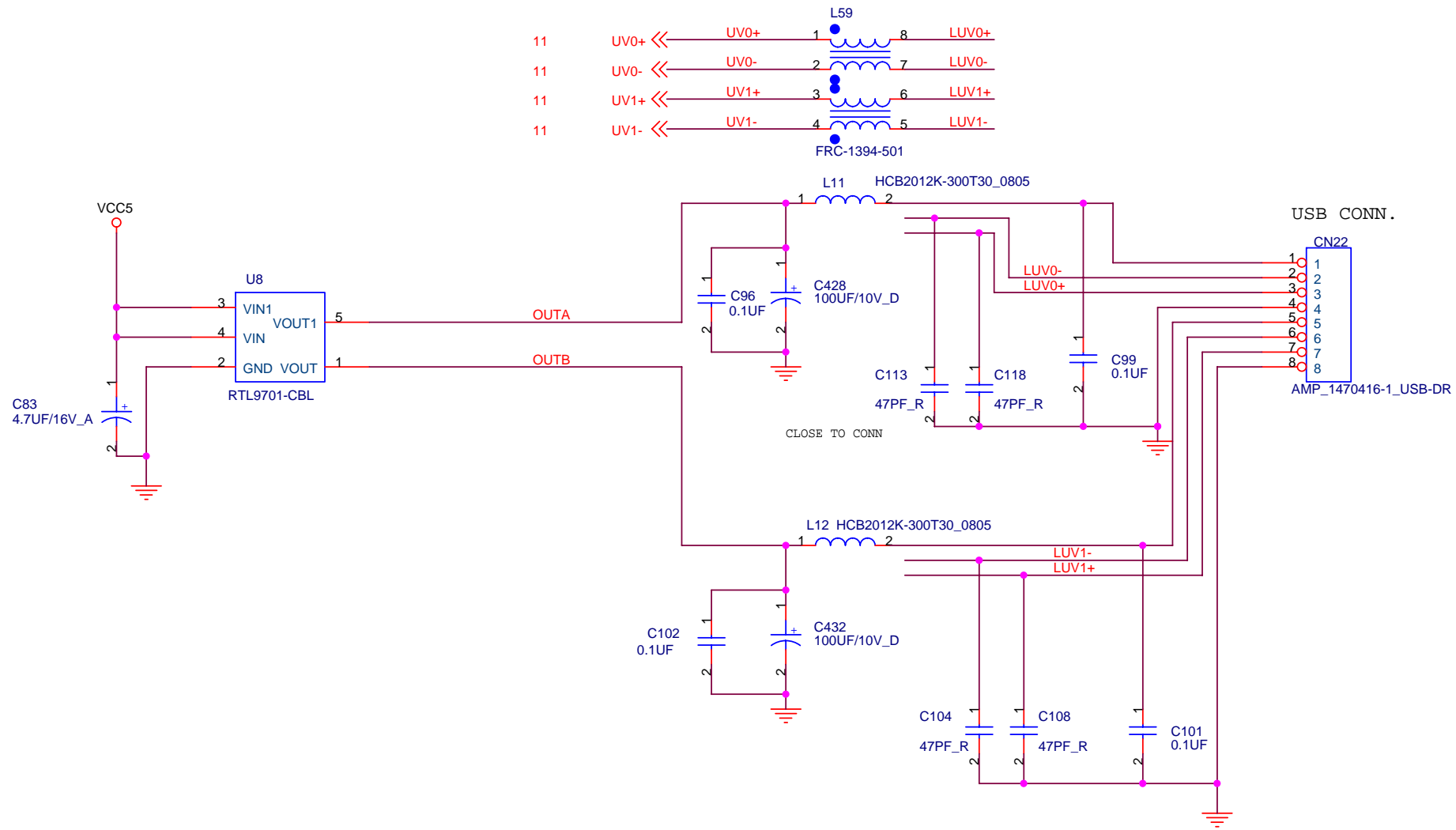

CLOSE TO SIS963

UV[3,0]±	controller 0
UV[4,1]±	controller 1
UV[5,2]±	controller 2

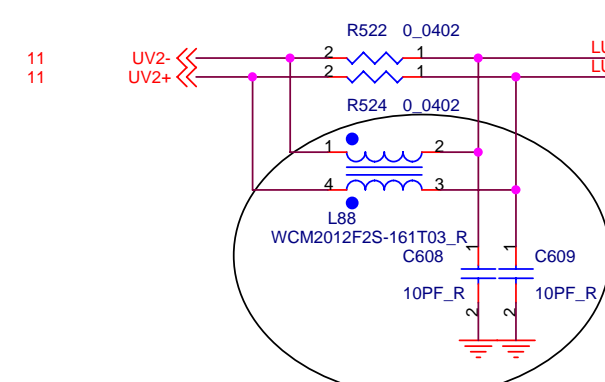
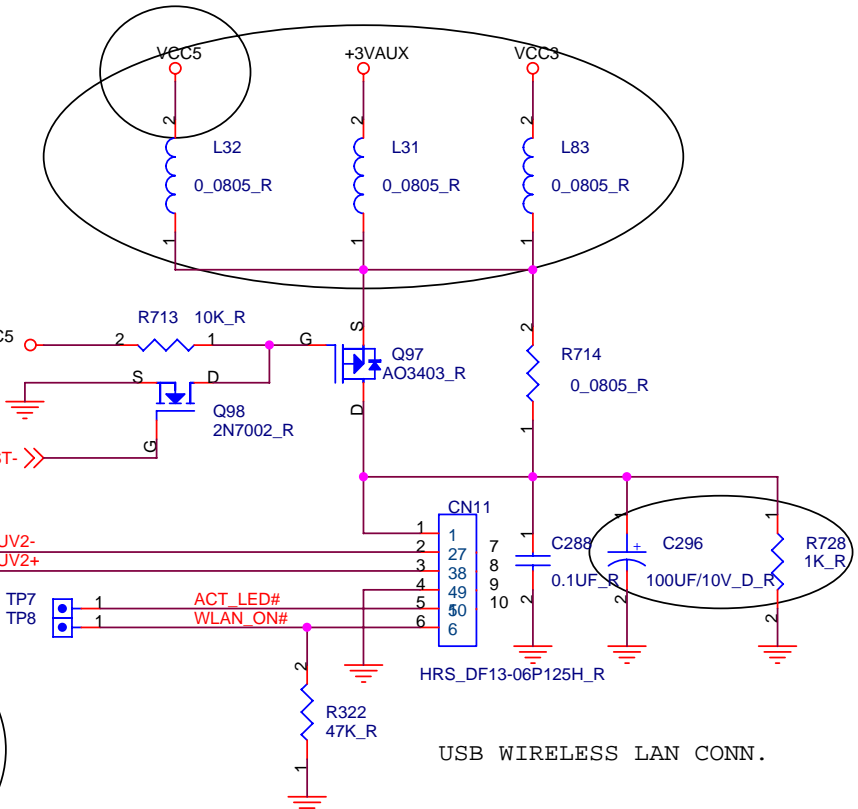

ECS CORP. (G733G M/B)		
Title USB PORT & USBLAN		
Size A3	Document Number G733G-1-3-01	Rev 4.0
Date: Wednesday, January 12, 2005	Sheet 27	of 39

RTL8201

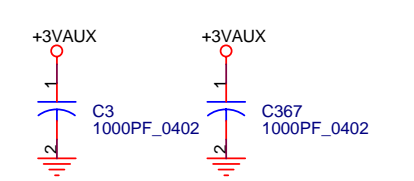
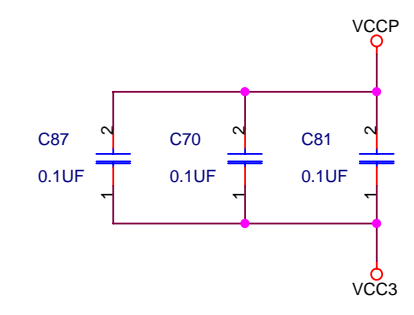
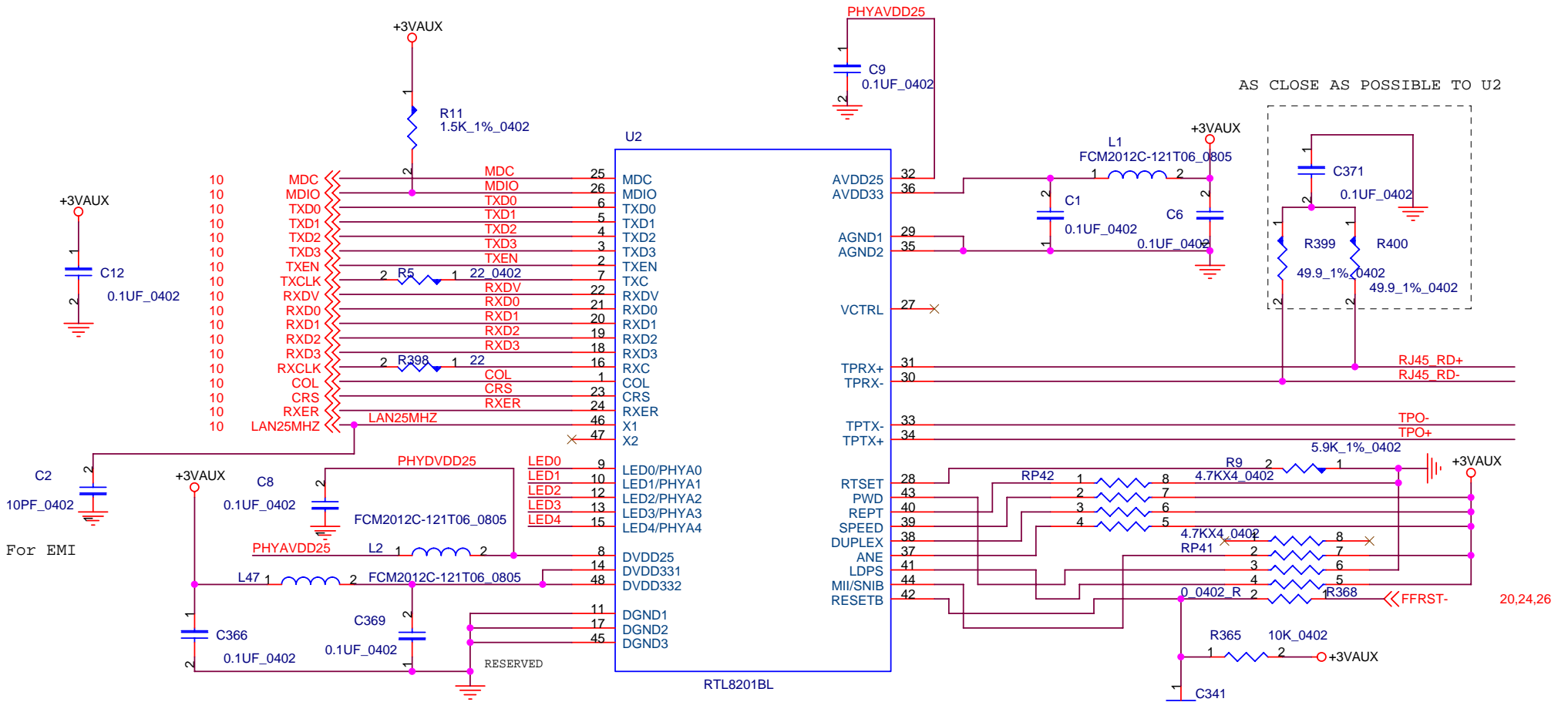

Config:
 Enable: N-way, Full duplex, 100Mbps, Link Down Power Saving
 Disable: Isolate, Repeater Mode

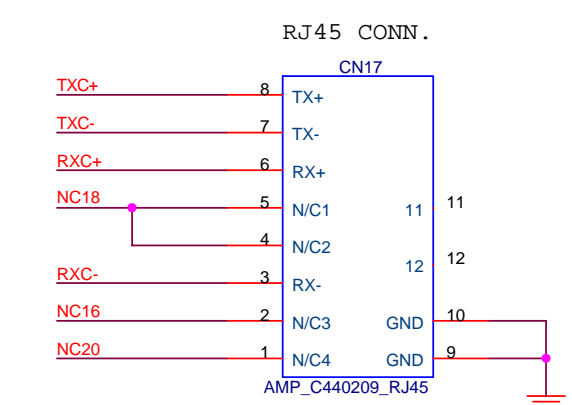
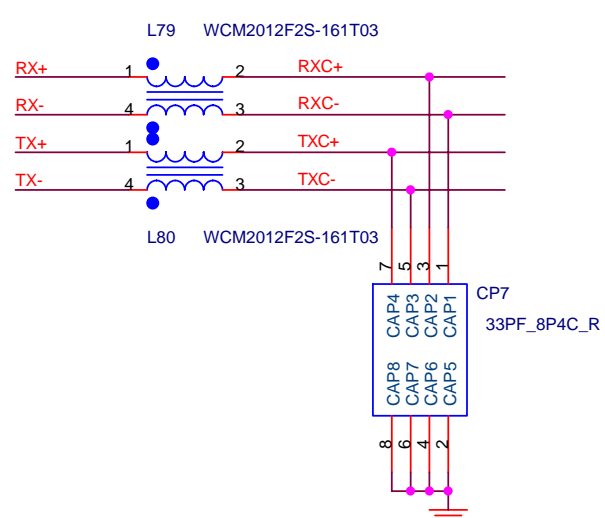
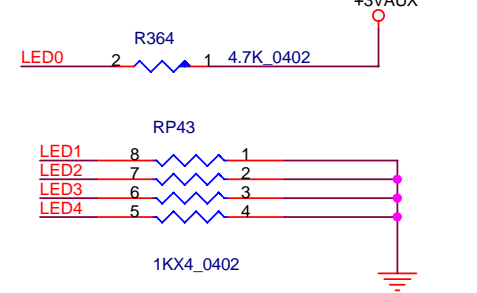
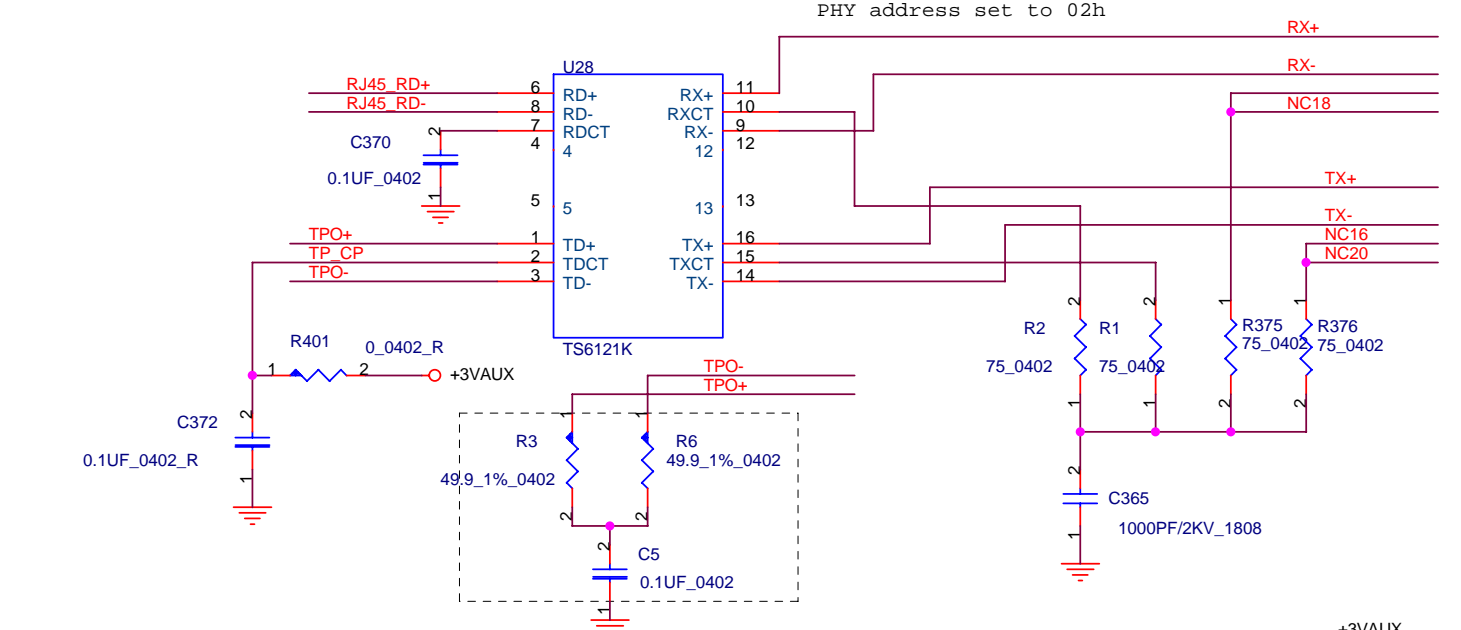

ECS CORP. (G733G M/B)		
Title RTL8201 LAN PHY		
Size A3	Document Number G733G-1-3-01	Rev 4.0
Date: Wednesday, January 12, 2005	Sheet 28	of 39

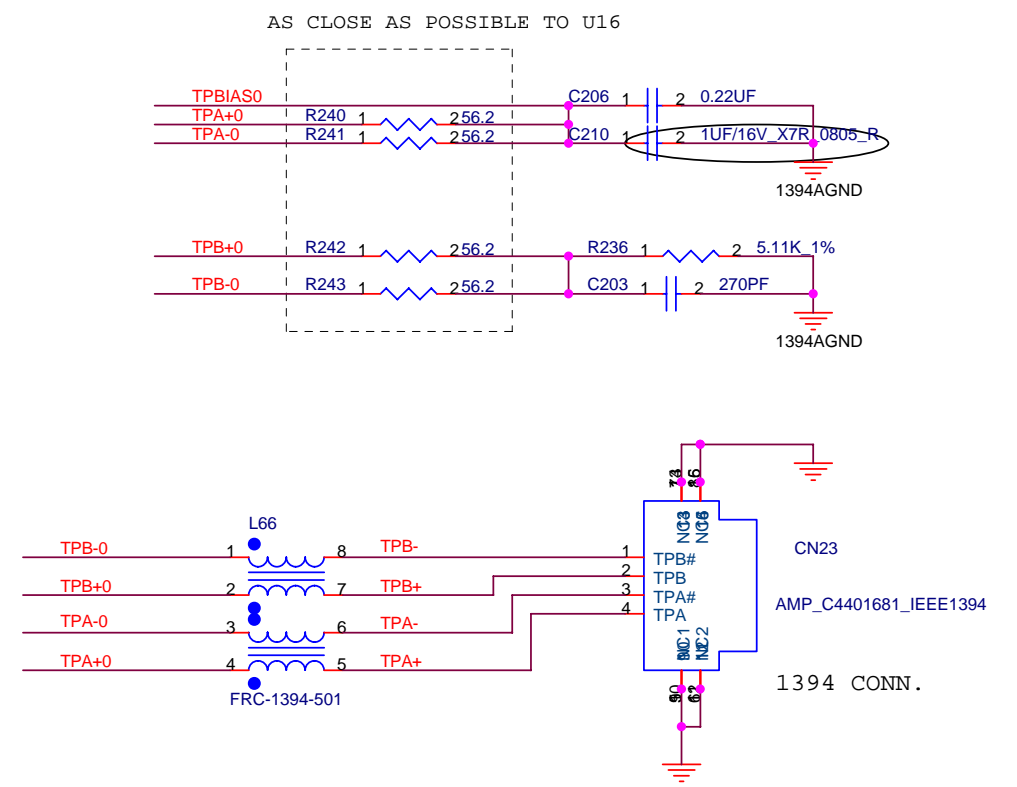
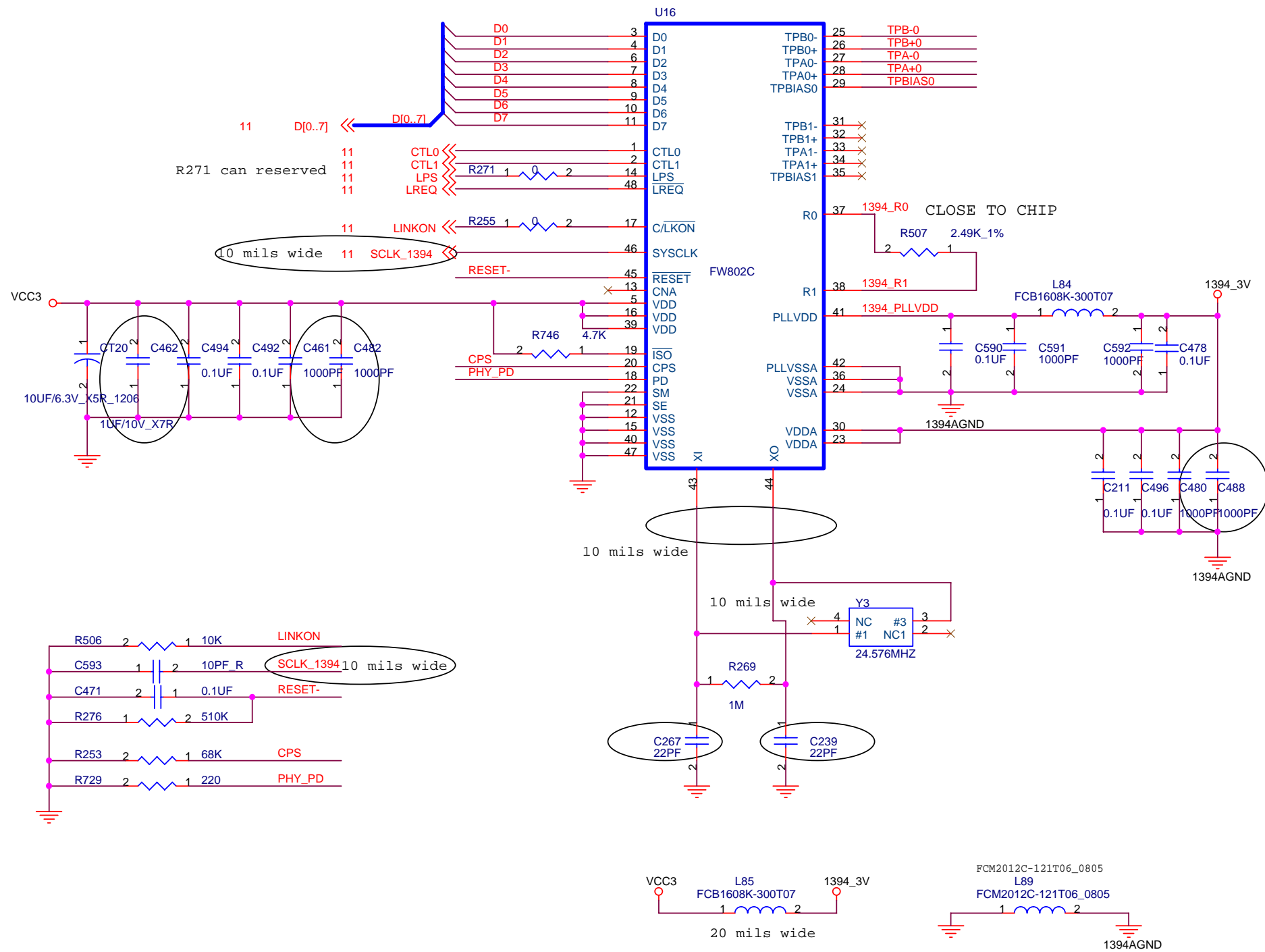

ECS CORP. (G733G M/B)		
Title AgereFW802C 1394 PHY		
Size A3	Document Number G733G-1-3-01	Rev 4.0
Date: Wednesday, January 12, 2005	Sheet 29	of 39

RTC

NOTE!

- 1.The RTCVDD is 3V
- 2.Decoupling capacitor must be close to 661 RTCVDD pin.
- 3.RTC circuit must strictly follow SiS's recommended design
SiS is not responsible for RTC problems from foreign designs.

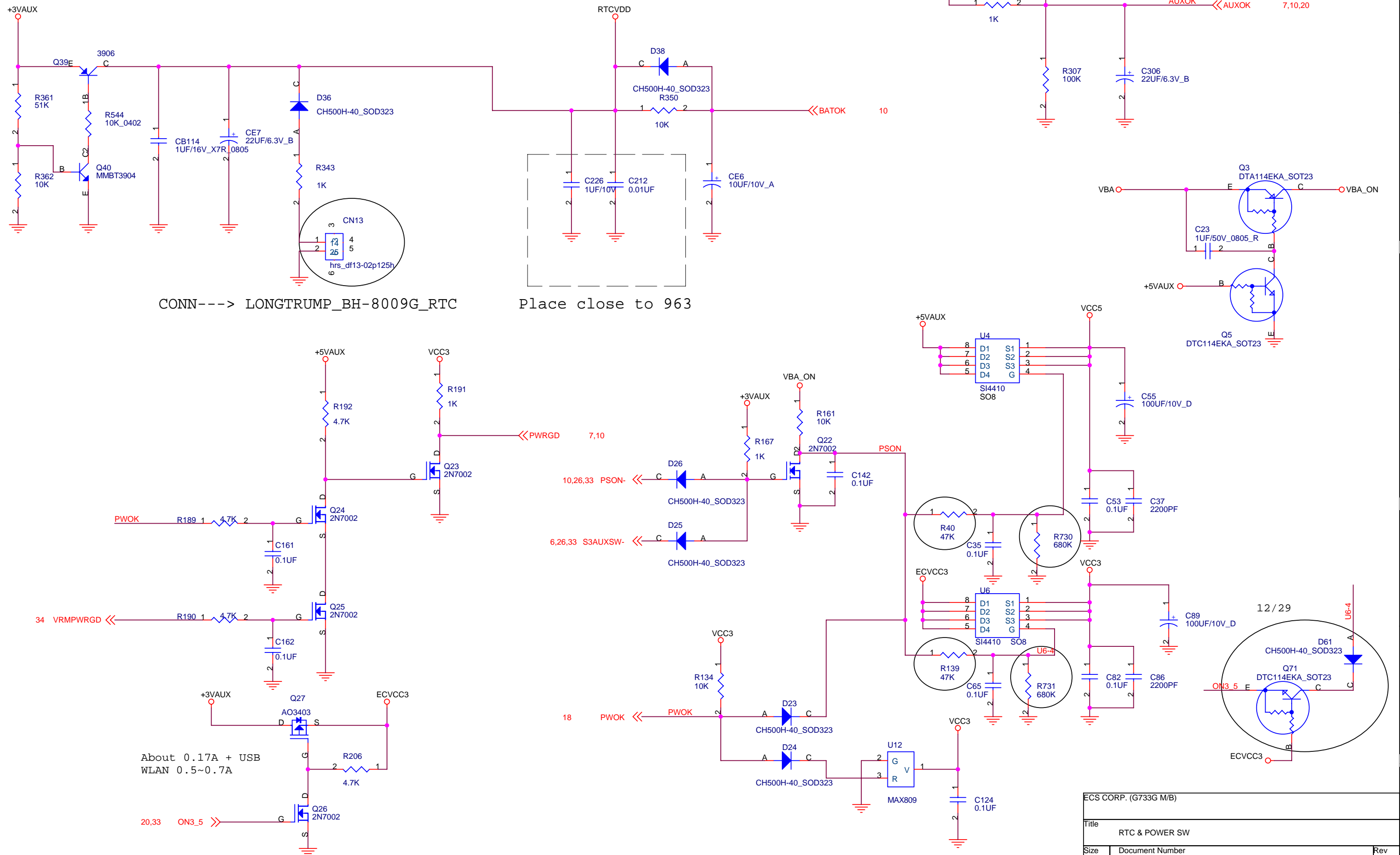

ECS CORP. (G733G M/B)		
Title RTC & POWER SW		
Size A3	Document Number G733G-1-3-01	Rev 4.0
Date: Wednesday, January 12, 2005	Sheet 30	of 39

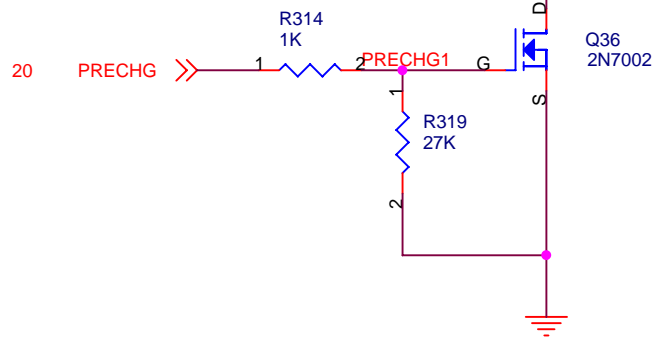
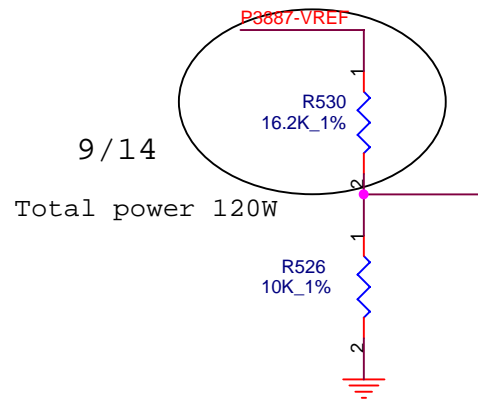
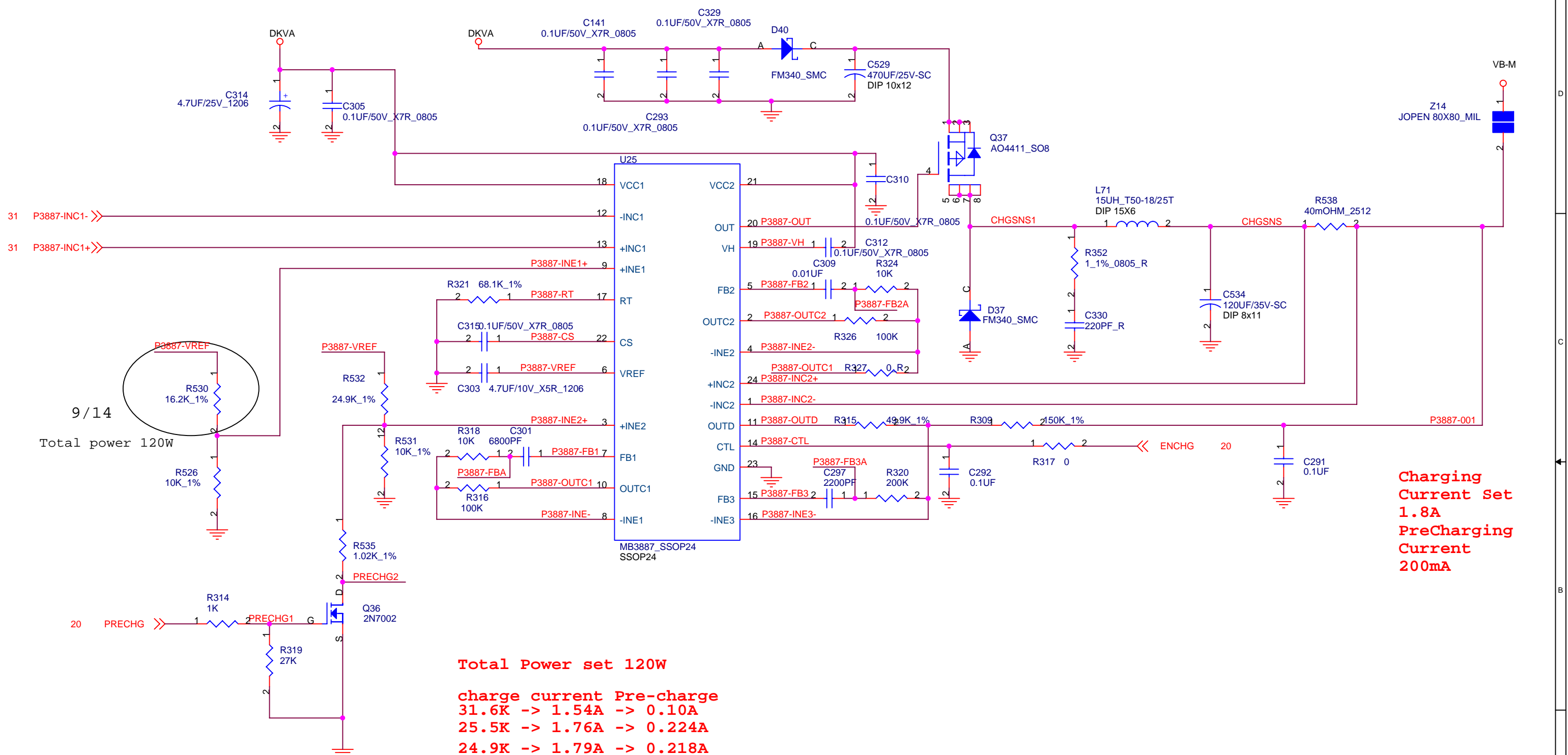

Total Power set 120W

charge current Pre-charge

31.6K -> 1.54A -> 0.10A

25.5K -> 1.76A -> 0.224A

24.9K -> 1.79A -> 0.218A

Charging Current Set 1.8A

PreCharging Current 200mA

ECS CORP. (G733G M/B)		
Title MB3887 CHARGER		
Size B	Document Number G733G-1-3-01	Rev 4.0
Date: Wednesday, January 12, 2005	Sheet 32	of 39

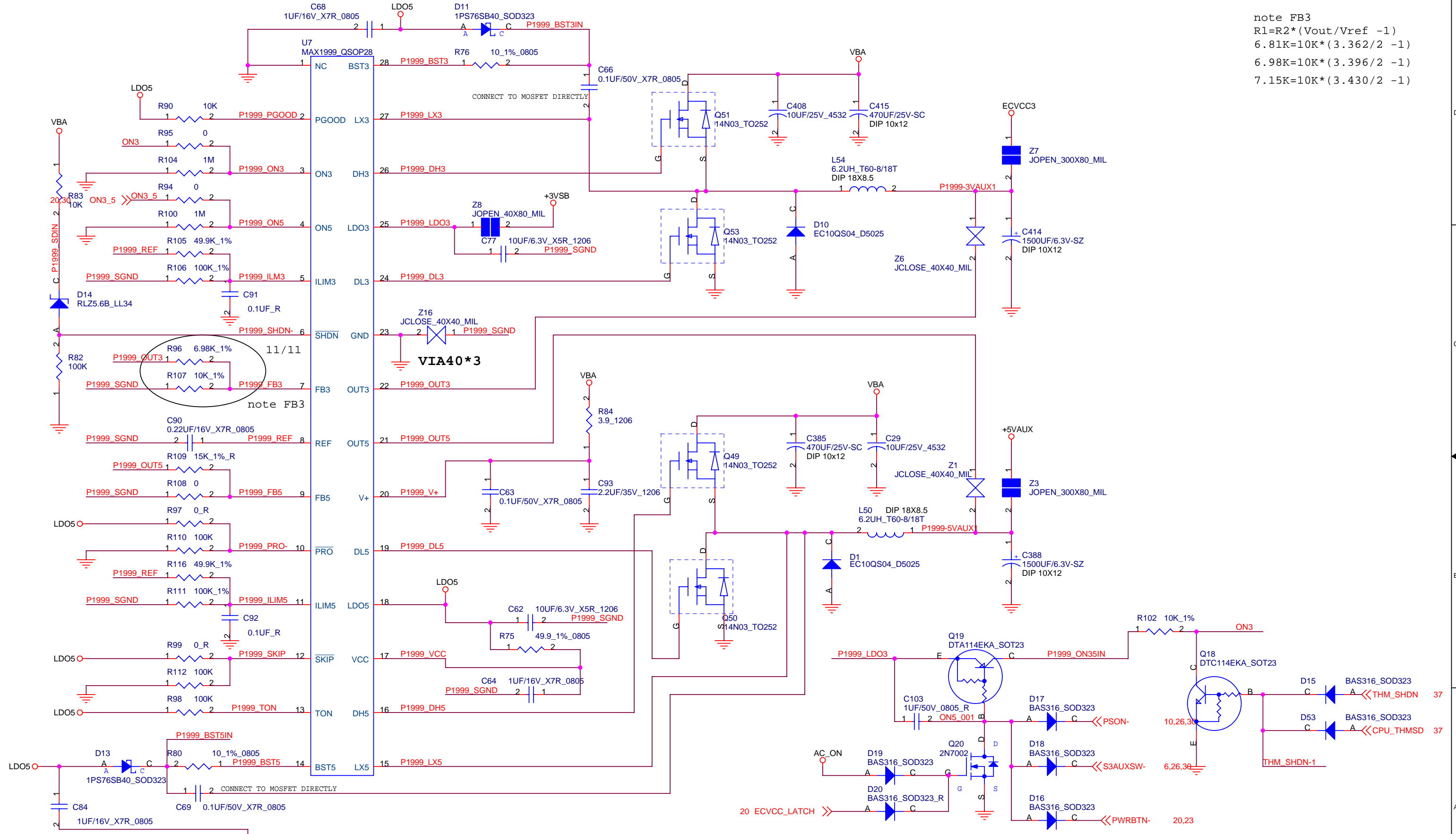

note FB3
 $R1=R2*(V_{out}/V_{ref} -1)$
 $6.81K=10K*(3.362/2 -1)$
 $6.98K=10K*(3.396/2 -1)$
 $7.15K=10K*(3.430/2 -1)$

ECS CORP. (G733G M/B)			
Title MAX 1999 SYSTEM POWER			
Size Custom	Document Number G733G-1-3-01		Rev 4.0
Date:	Wednesday, January 12, 2005	Sheet 33	of 39

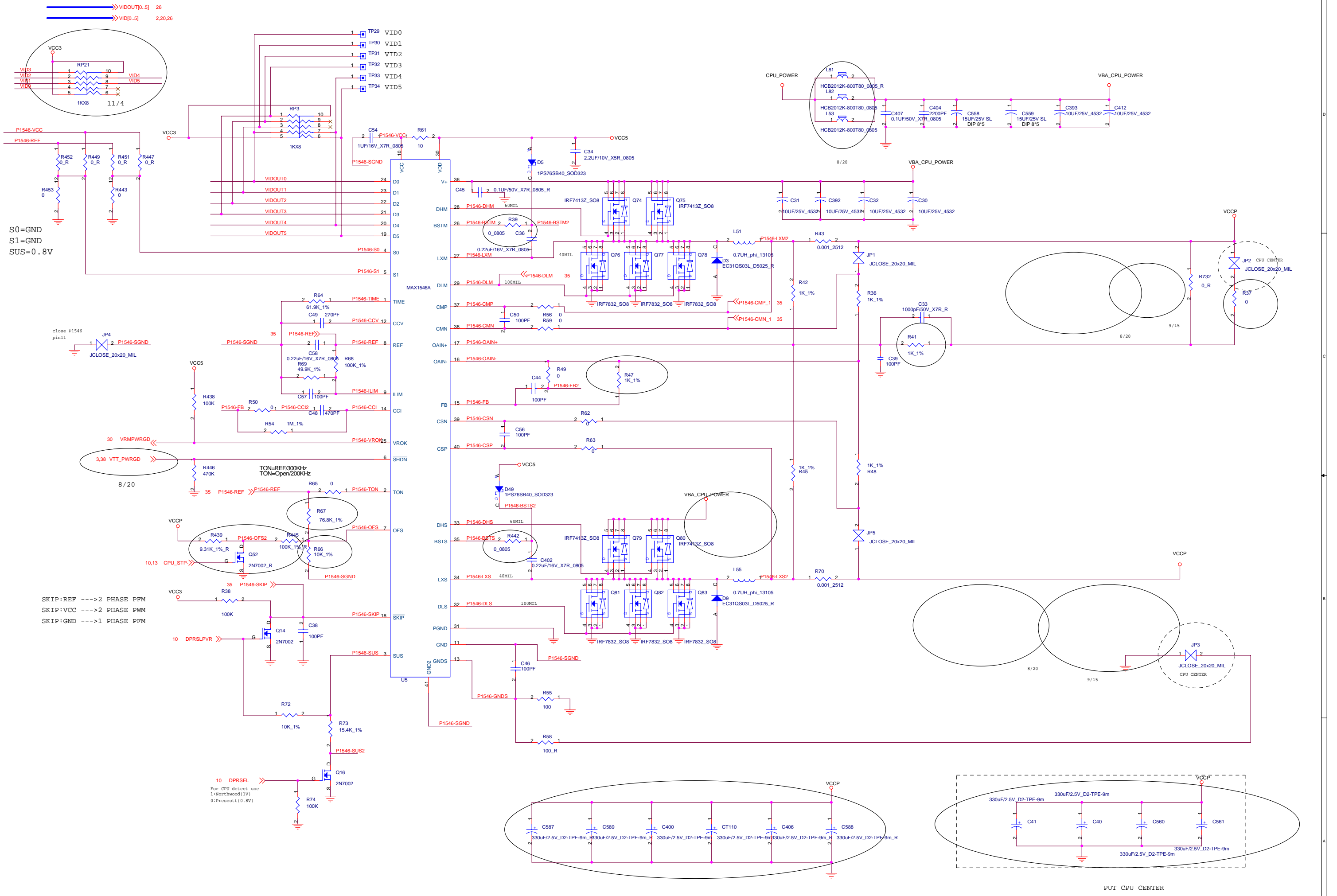

S0=GND
S1=GND
SUS=0.8V

close P1546
pin11

TON=REF/300KHz
TON=Open/200KHz

SKIP:REF ---> 2 PHASE PFM
SKIP:VCC ---> 2 PHASE PWM
SKIP:GND ---> 1 PHASE PFM

10 DPRSEL
For CPU detect use
1:Northwood(1V)
0:Prescott(0.8V)

Title			MAX1546 CPU POWER
Size	Document Number	Rev	
	G733G-1-3-01	4.0	
Date:	Wednesday, January 12, 2005	Sheet	34 of 39

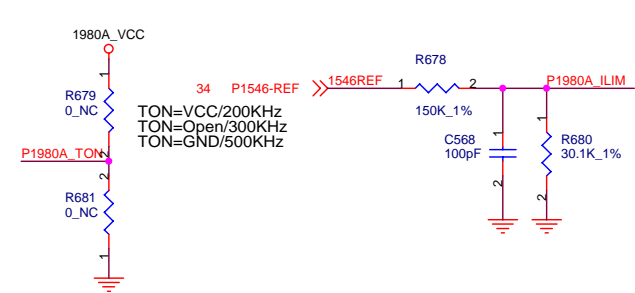
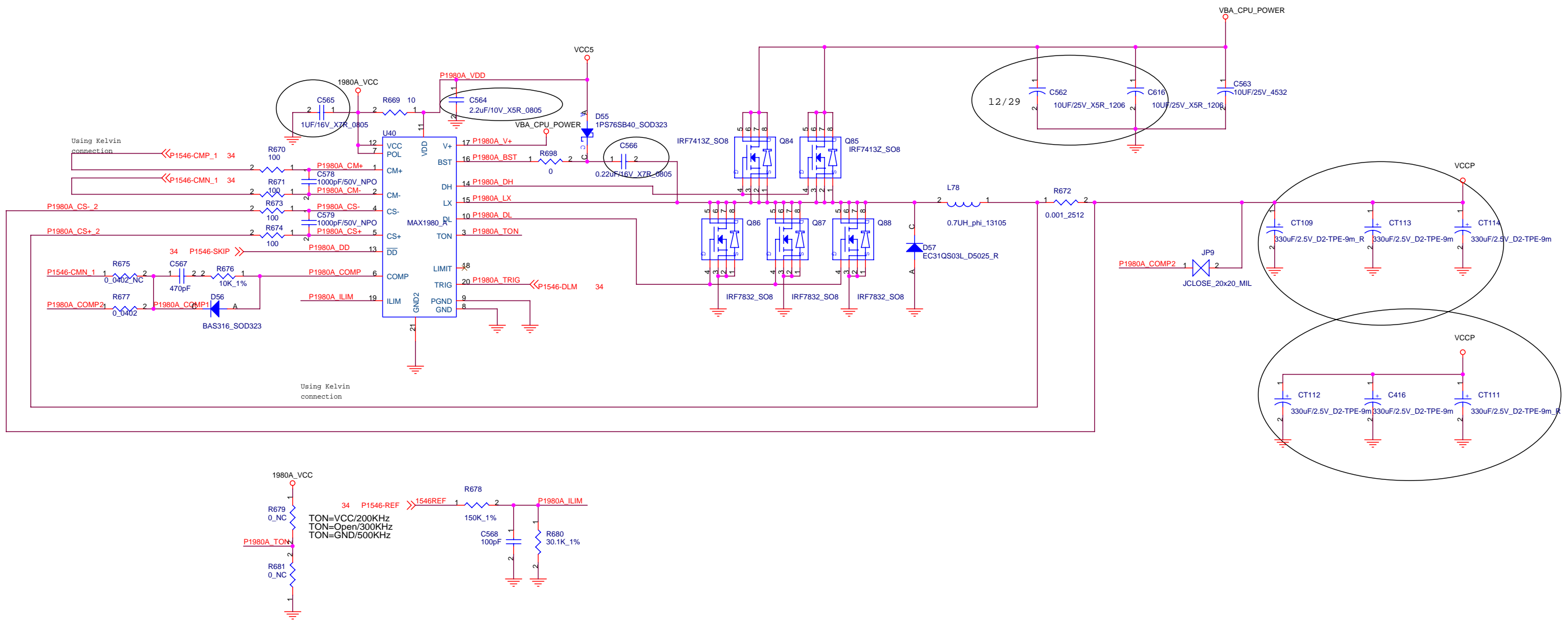

ECS CORP. (G733E M/B)			
Title: MAX1980 CPU POWER			
Size: C	Document Number: G733G-1-3-01	Rev: 4.0	
Date: Wednesday, January 12, 2005	Sheet: 35	of:	39

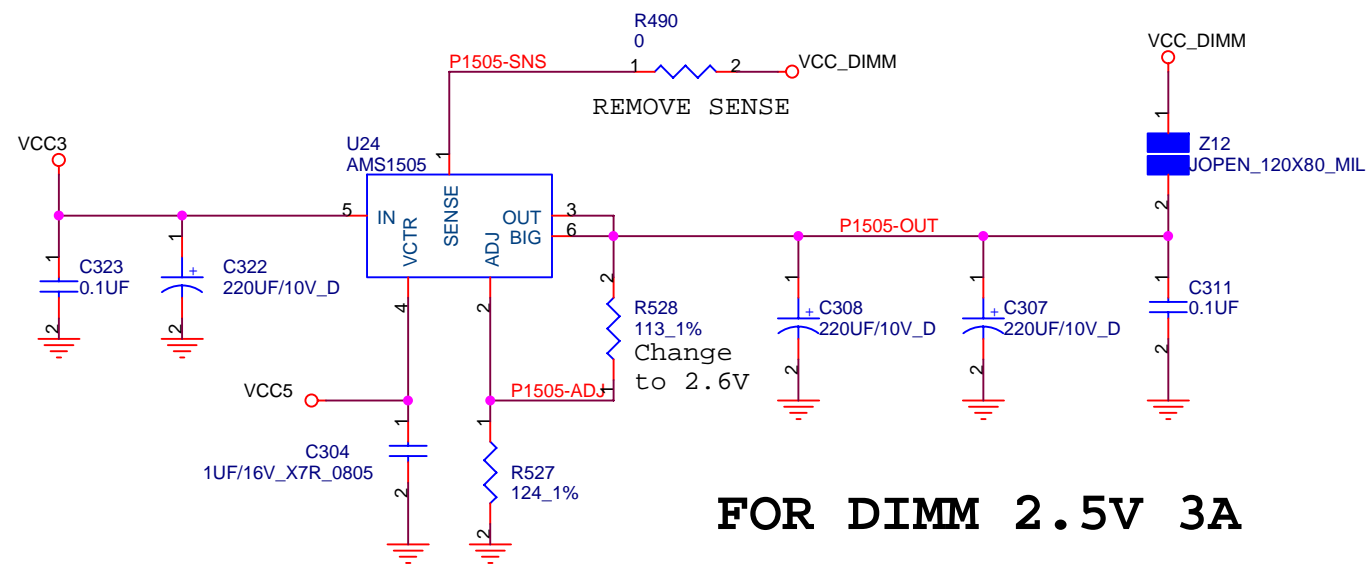
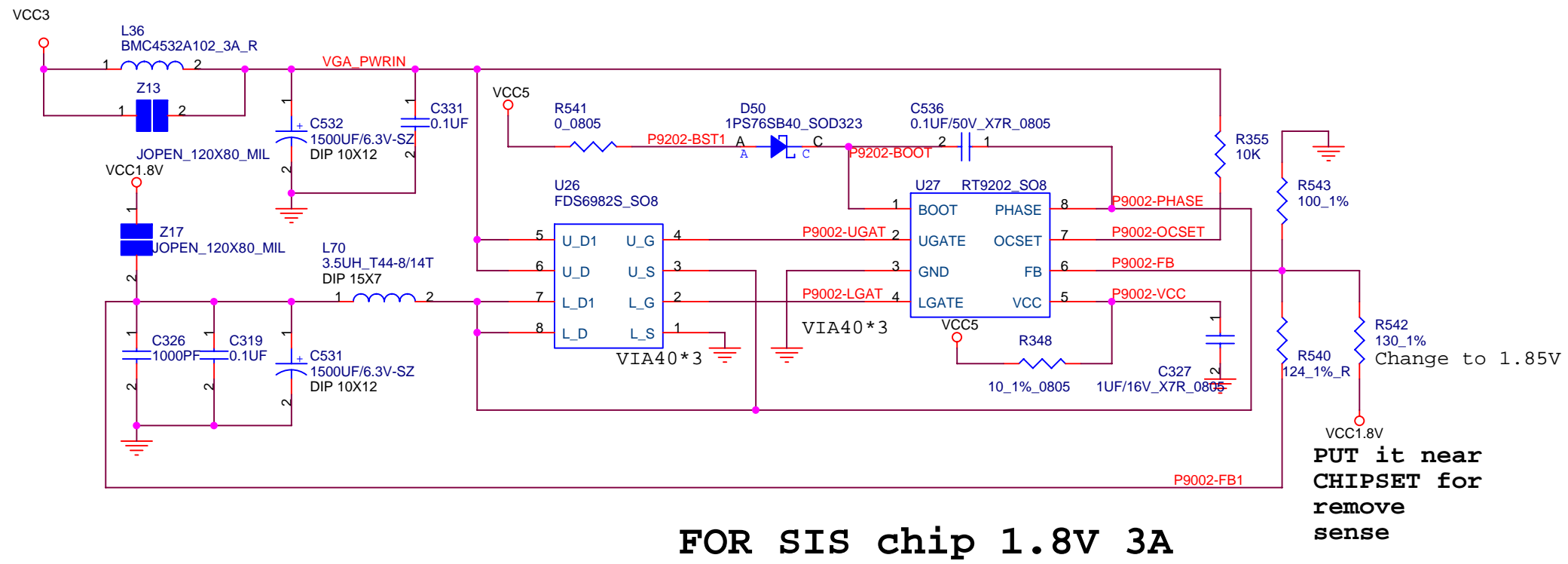

ECS CORP. (G733G M/B)		
Title CHIPSET POWER & DDR2.5V		
Size B	Document Number G733G-1-3-01	Rev 4.0
Date: Wednesday, January 12, 2005	Sheet 36	of 39

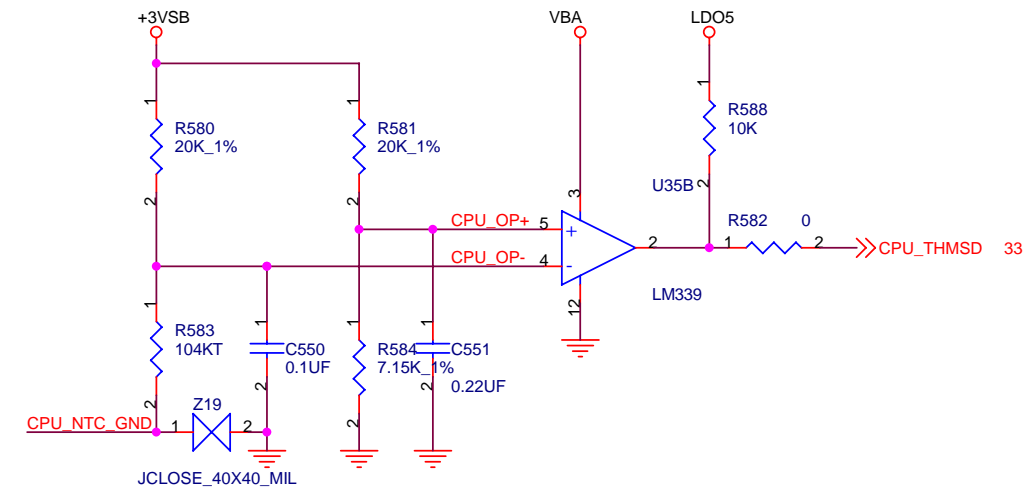
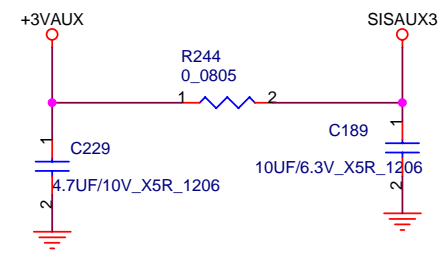

OVER 95 C PROTECT

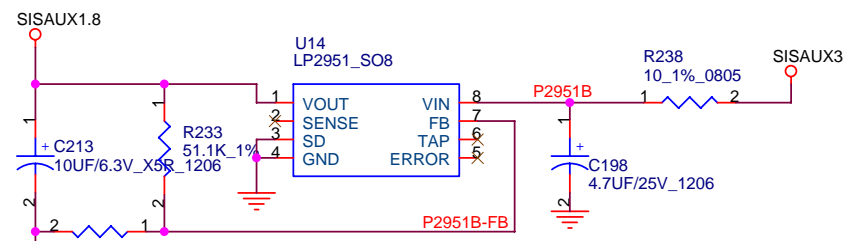

**+1.8VSB SUPPLY
30mA FOR SIS
1.8AUX**

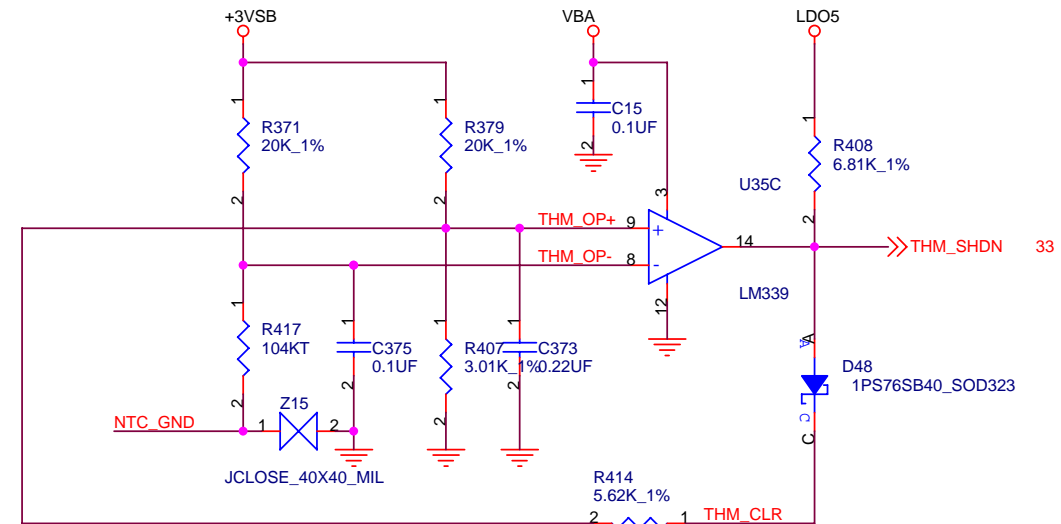

OVER 120 C PROTECT, BUT CLEAR AT < 60 C

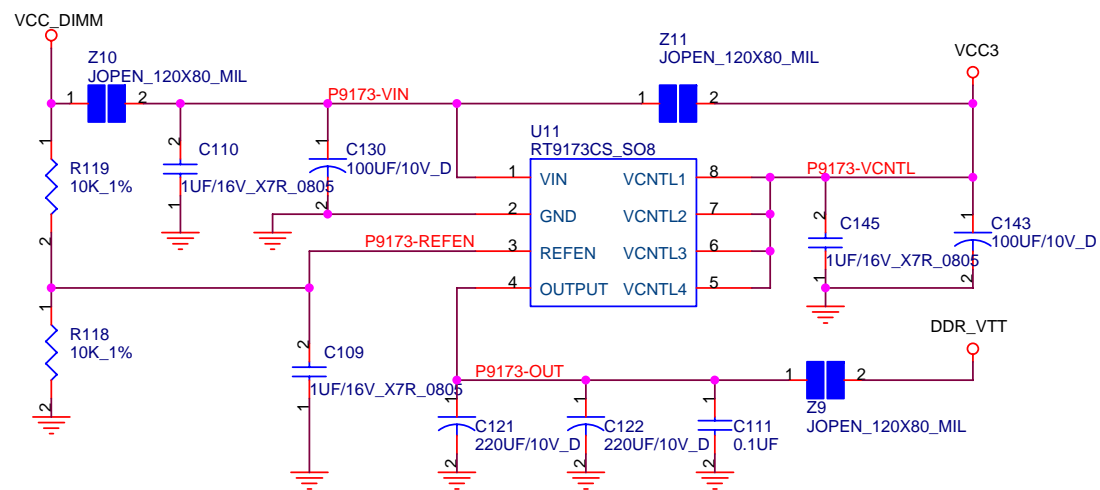

FOR DDR_VTT 1.25V 1.5A

ECS CORP. (G733G M/B)		
Title LDO & DDRVTT POWER		
Size Custom	Document Number G733G-1-3-01	Rev 4.0
Date: Wednesday, January 12, 2005	Sheet 37	of 39

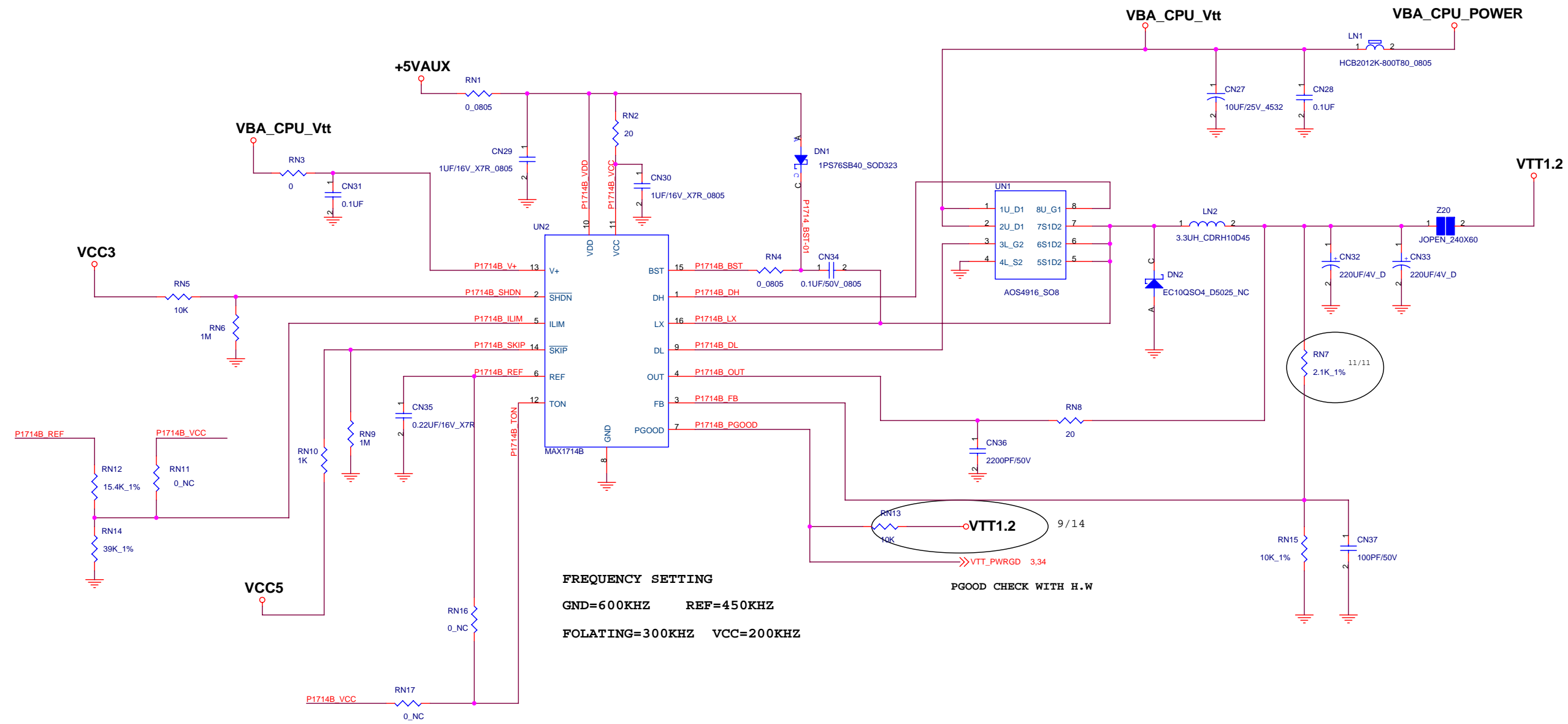

FREQUENCY SETTING
GND=600KHZ REF=450KHZ
FOLATING=300KHZ VCC=200KHZ

VTT1.2 9/14
VTT_PWRGD 3,34
PGOOD CHECK WITH H.W

ECS CORP. (G733G M/B)		
Title CPU_VTT_MAX1714		
Size Custom	Document Number G733G-1-3-01	Rev 4.0
Date: Wednesday, January 12, 2005	Sheet 38	of 39

HISTORY:**A.0 : INITAL 12/31**

POWER: 1.ADD C33,C39,C50,C56 improve waveform.(page.34)

2.DEL R34,R60.(page.34)

H/W: 3.CHANGE RP29 TO 47ohm, SIS recommend value.(page.16)

B.0 : 2/25

POWER: 1.Remove C33 to improve waveform.R528 124->113 RAM VOL.(page.34&35)

2.CHANGE R39,R442 TO SLOVE FSB800 CAN'T BOOT PROBLEM.(page.34)

H/W: 3.CHANGE FOOTPRINT RP21,RP23,RP44,R268,R273,R284,R289.(page.20&34)

4.ADD Prescott C-step processor solution Q60,R558,R295 4.7K->470 ohm.(page.3&10)

5.ADD BOM Q32,Q33,Q35,R511,D25,D33 FOR SYSTEM STATUS.(page.6&26)

6.CHANGE R115,R120 TO 14_1% & 100_1% FOR SIS RECOMMEND.(page.5)

7.DPRSLEPVR NEED PULL LOW to improve VCCP waveform,R559.(page.10)

8.ADD VID4(R564,R565_R,R566,R567),FAN FB (Q61,R560,R561,R20,R472).(page.20&34)

9.ADD PWRBTN-,ON3_5 pull high R562,R563, and CHANGE PWRSW- TO PIN1.(page.20)

10.ADD VCCP,PVID5 TO PIN90,168,and LM90's EC_SMBUS CHANGED(del R284,R289 add R268,R273).(page.20)

11.SIS 302LV DEL C429 for panel prob,CHANGE R77 2K->24K SIS recommend.(page.22)

12.LID SOL:REPLACE D46 BY Q62,and MOVE D46.A TO Q1.S THEN ADD R570 to Q1.S pull high.(page.23)

13.uP add VID5(R576,R577_R,R578,R579).(page.20&34)

14.Reserved RP58(CKE),D24(POWRGD FASTER),R574(C-step),R279&C256(panel ID).(page.xx)

15.EC_SMBUS pull high(R571,R572).R509->100Kpull low,R514 0->4.7K pull high for sys-status.(page.20&26)

16.AC'97 EMI:Change C540,C545(680pF->33pF).R550,R552,R294(301FCM->471BK).(page.18)

17.ADD Third system fan controller(Q63,CT67,R586,C553,D54).(page.20)

POWER: 18.R355 4.7K->10K.(page.35)

H/W: 19.SMBUS OF RAM BUFFER CUT OFF(Reserved R555,R556).(page.14)

1.0 : 4/23

POWER: 20.throught rate change to 100us, R64 30.1K -> 61.9K.(page.34)

21.charge current 1.5A -> 1.8A, R532 31.6K -> 24.9K.(page.32)

H/W: 22.ON3_5 thermal protect add Q65,Q66,Q71,R590.(page.30)

23.Add Bus Switch U36,SW2,Q70,R597,R598,CT68,RP72.(page.26)

24.Add panel SMBUS.(page.23)

25.Add SIS recommend circuit of CPURST-(page.3)

1.A : 5/12

POWER: 26.SET TOTAL POWER TO 90W R530 30.1K->26.7K.(page.32)

H/W: 27.EC RST NEED MORE TIME R300 10K->47K.(page.20)

1.B : 7/06

POWER: 28.Change VCC1.8 to 1.85V, R542 124ohm -> 130ohm.(page.35)

H/W: 29.GTLREF change to 100:169 VCCP.(page.3)

3.0 : 11/12

POWER: 30..(page.??)

H/W: