

Test Laboratory: Compliance Certification Services

2_Host # 2_Dell Laptop

DUT: Airgo; Type: AGN1022PC-01; Serial: 6154W007931

Communication System: 802.11bg; Frequency: 2412 MHz; Duty Cycle: 1:1

Medium parameters used (interpolated): $f = 2412$ MHz; $\sigma = 1.94$ mho/m; $\epsilon_r = 51.9$; $\rho = 1000$ kg/m³

Phantom section: Flat Section

Room Ambient Temperature: 24 deg. C; Liquid Temperature: 23 deg. C

DASY4 Configuration:

- Area Scan setting - Find Secondary Maximum Within: 2.0 dB and with a peak SAR value greater than 0.0012W/kg
- Probe: EX3DV4 - SN3552 ; ConvF(6.94, 6.94, 6.94); Calibrated: 3/19/2005
- Sensor-Surface: 2.5mm (Mechanical Surface Detection)
- Electronics: DAE3 Sn500; Calibrated: 2/7/2005
- Phantom: SAM 2; Type: SAM 2; Serial: 1050
- Measurement SW: DASY4, V4.5 Build 19; Postprocessing SW: SEMCAD, V1.8 Build 146

b mode, L-ch (P: 19)/Area Scan (11x8x1): Measurement grid: dx=15mm, dy=15mm

[Info: Interpolated medium parameters used for SAR evaluation!](#)

Maximum value of SAR (measured) = 0.800 mW/g

b mode, L-ch (P: 19)/Zoom Scan (5x5x7)/Cube 0: Measurement grid: dx=7.5mm, dy=7.5mm, dz=5mm

Reference Value = 13.8 V/m; Power Drift = -0.128 dB

Peak SAR (extrapolated) = 1.05 W/kg

SAR(1 g) = 0.612 mW/g; SAR(10 g) = 0.331 mW/g

[Info: Interpolated medium parameters used for SAR evaluation!](#)

Maximum value of SAR (measured) = 0.786 mW/g

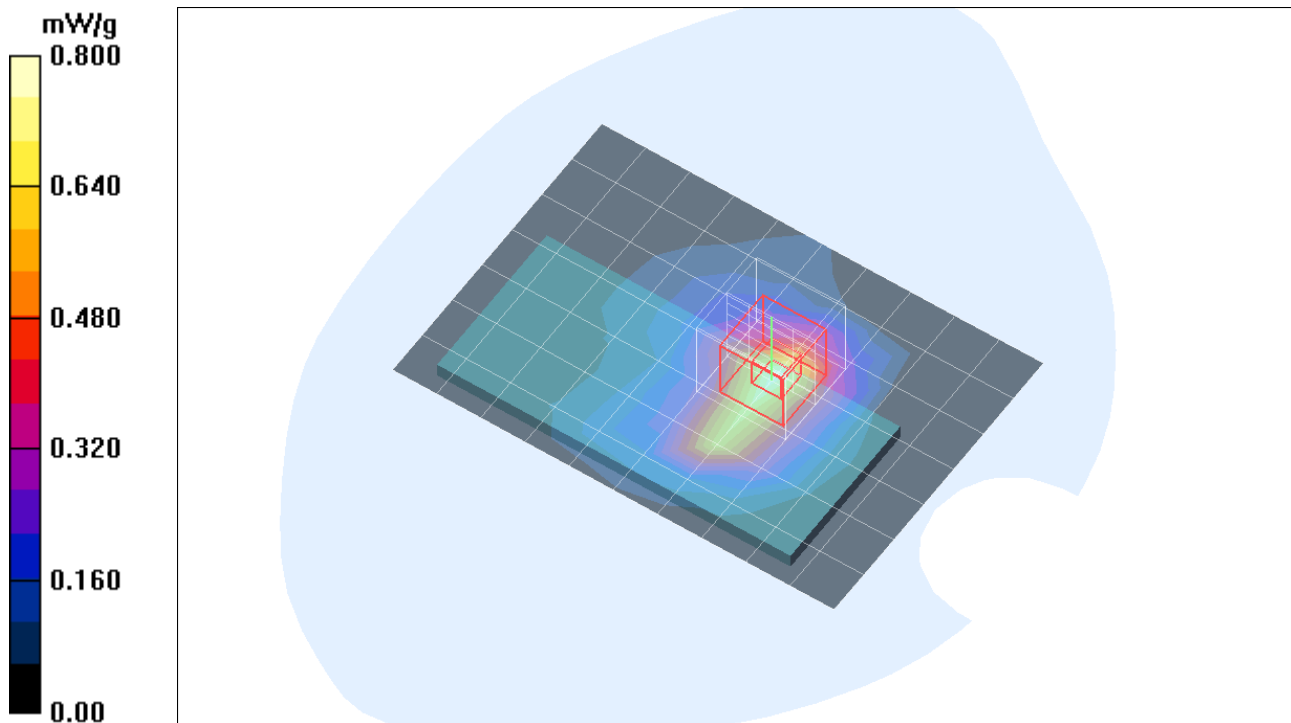

Test Laboratory: Compliance Certification Services

2_Host # 2_Dell Laptop

DUT: Airgo; Type: AGN1022PC-01; Serial: 6154W007931

Communication System: 802.11bg; Frequency: 2437 MHz; Duty Cycle: 1:1

Medium parameters used (interpolated): $f = 2437$ MHz; $\sigma = 1.98$ mho/m; $\epsilon_r = 51.8$; $\rho = 1000$ kg/m³

Phantom section: Flat Section

Room Ambient Temperature: 24 deg. C; Liquid Temperature: 23 deg. C

DASY4 Configuration:

- Area Scan setting - Find Secondary Maximum Within: 2.0 dB and with a peak SAR value greater than 0.0012W/kg
- Probe: EX3DV4 - SN3552 ; ConvF(6.94, 6.94, 6.94); Calibrated: 3/19/2005
- Sensor-Surface: 2.5mm (Mechanical Surface Detection)
- Electronics: DAE3 Sn500; Calibrated: 2/7/2005
- Phantom: SAM 2; Type: SAM 2; Serial: 1050
- Measurement SW: DASY4, V4.5 Build 19; Postprocessing SW: SEMCAD, V1.8 Build 146

b mode, M-ch (P: 20)/Area Scan (11x8x1): Measurement grid: dx=15mm, dy=15mm

[Info: Interpolated medium parameters used for SAR evaluation!](#)

Maximum value of SAR (measured) = 1.01 mW/g

b mode, M-ch (P: 20)/Zoom Scan (5x5x7)/Cube 0: Measurement grid: dx=7.5mm, dy=7.5mm, dz=5mm

Reference Value = 15.9 V/m; Power Drift = -0.173 dB

Peak SAR (extrapolated) = 1.43 W/kg

SAR(1 g) = 0.793 mW/g; SAR(10 g) = 0.425 mW/g

[Info: Interpolated medium parameters used for SAR evaluation!](#)

Maximum value of SAR (measured) = 1.03 mW/g

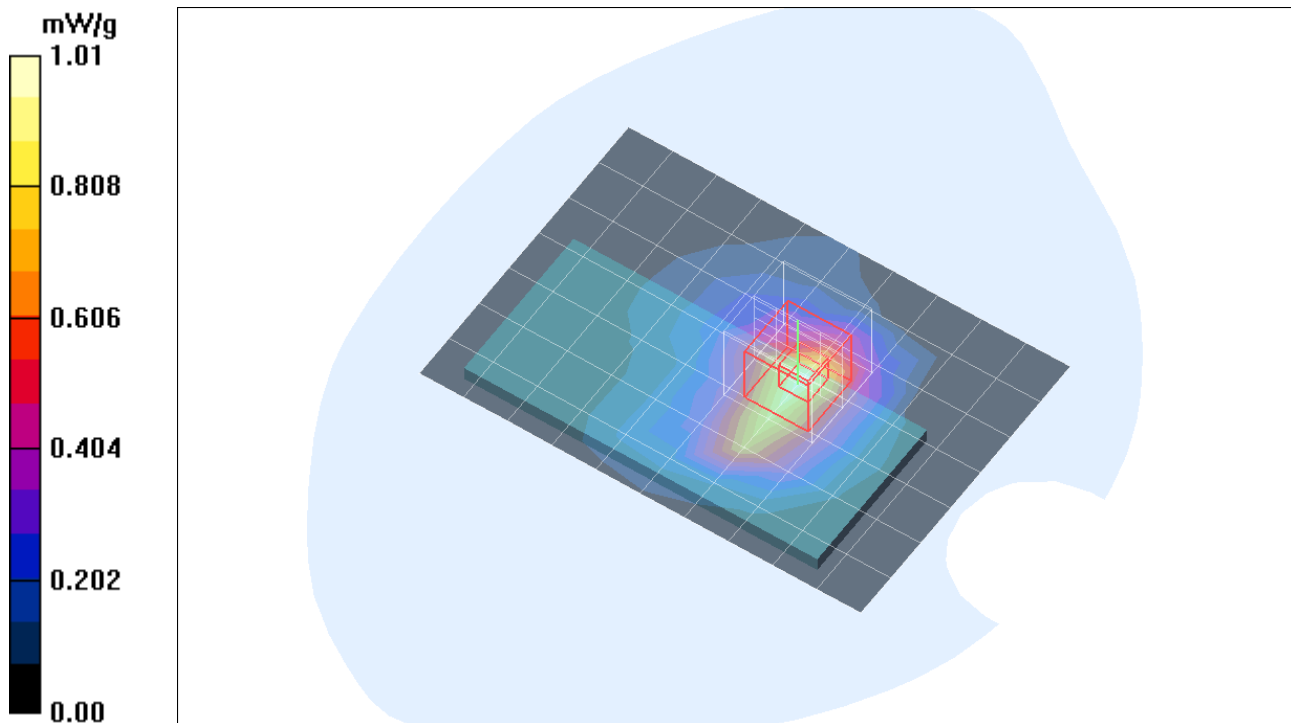

Test Laboratory: Compliance Certification Services

2_Host # 2_Dell Laptop

DUT: Airgo; Type: AGN1022PC-01; Serial: 6154W007931

Communication System: 802.11bg; Frequency: 2462 MHz; Duty Cycle: 1:1

Medium parameters used (interpolated): $f = 2462$ MHz; $\sigma = 2.01$ mho/m; $\epsilon_r = 51.7$; $\rho = 1000$ kg/m³

Phantom section: Flat Section

Room Ambient Temperature: 24 deg. C; Liquid Temperature: 23 deg. C

DASY4 Configuration:

- Area Scan setting - Find Secondary Maximum Within: 2.0 dB and with a peak SAR value greater than 0.0012W/kg
- Probe: EX3DV4 - SN3552 ; ConvF(6.94, 6.94, 6.94); Calibrated: 3/19/2005
- Sensor-Surface: 2.5mm (Mechanical Surface Detection)
- Electronics: DAE3 Sn500; Calibrated: 2/7/2005
- Phantom: SAM 2; Type: SAM 2; Serial: 1050
- Measurement SW: DASY4, V4.5 Build 19; Postprocessing SW: SEMCAD, V1.8 Build 146

b mode, H-ch (P: 19)/Area Scan (11x8x1): Measurement grid: dx=15mm, dy=15mm

[Info: Interpolated medium parameters used for SAR evaluation!](#)

Maximum value of SAR (measured) = 1.06 mW/g

b mode, H-ch (P: 19)/Zoom Scan (5x5x7)/Cube 0: Measurement grid: dx=7.5mm, dy=7.5mm, dz=5mm

Reference Value = 16.5 V/m; Power Drift = -0.123 dB

Peak SAR (extrapolated) = 1.45 W/kg

SAR(1 g) = 0.808 mW/g; SAR(10 g) = 0.436 mW/g

[Info: Interpolated medium parameters used for SAR evaluation!](#)

Maximum value of SAR (measured) = 1.05 mW/g

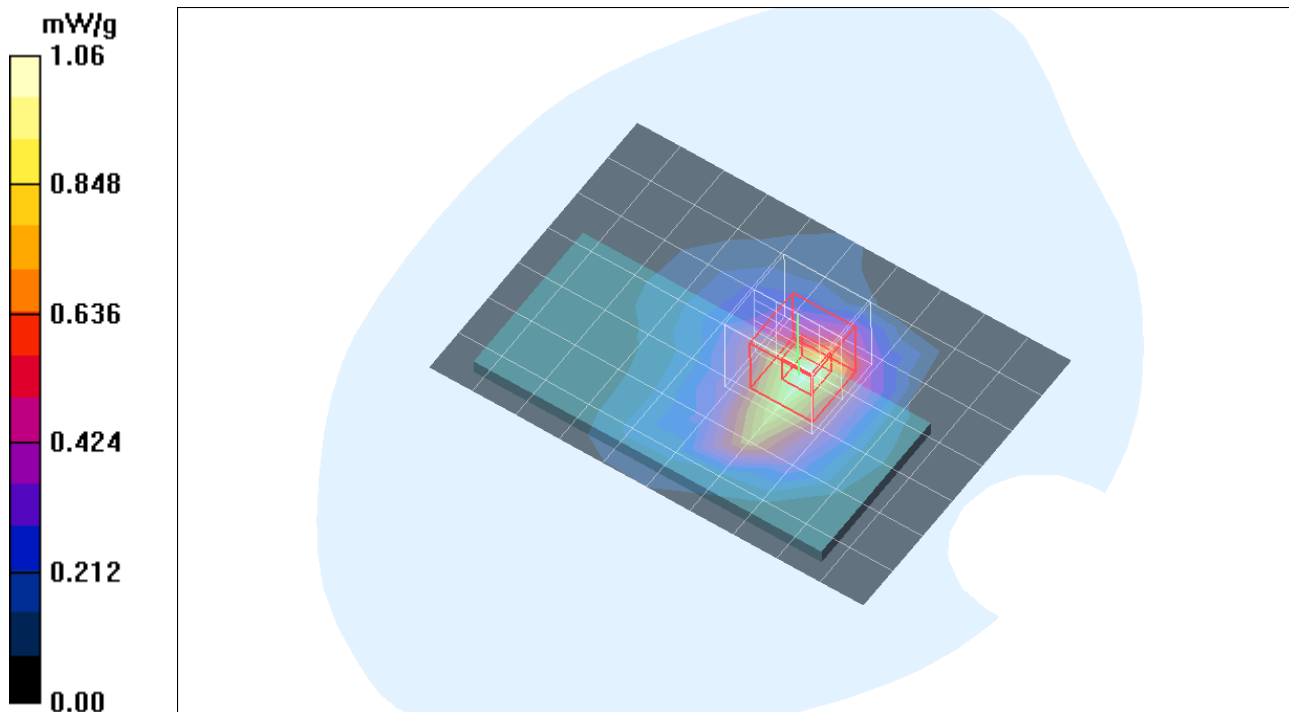

Test Laboratory: Compliance Certification Services

2_Host # 2_Dell Laptop

DUT: Airgo; Type: AGN1022PC-01; Serial: 6154W007931

Communication System: 802.11bg; Frequency: 2462 MHz;Duty Cycle: 1:1

b mode, H-ch (P: 19)/Z Scan (1x1x41): Measurement grid: dx=20mm, dy=20mm, dz=2.5mm

[Info: Interpolated medium parameters used for SAR evaluation!](#)

Maximum value of SAR (measured) = 1.07 mW/g

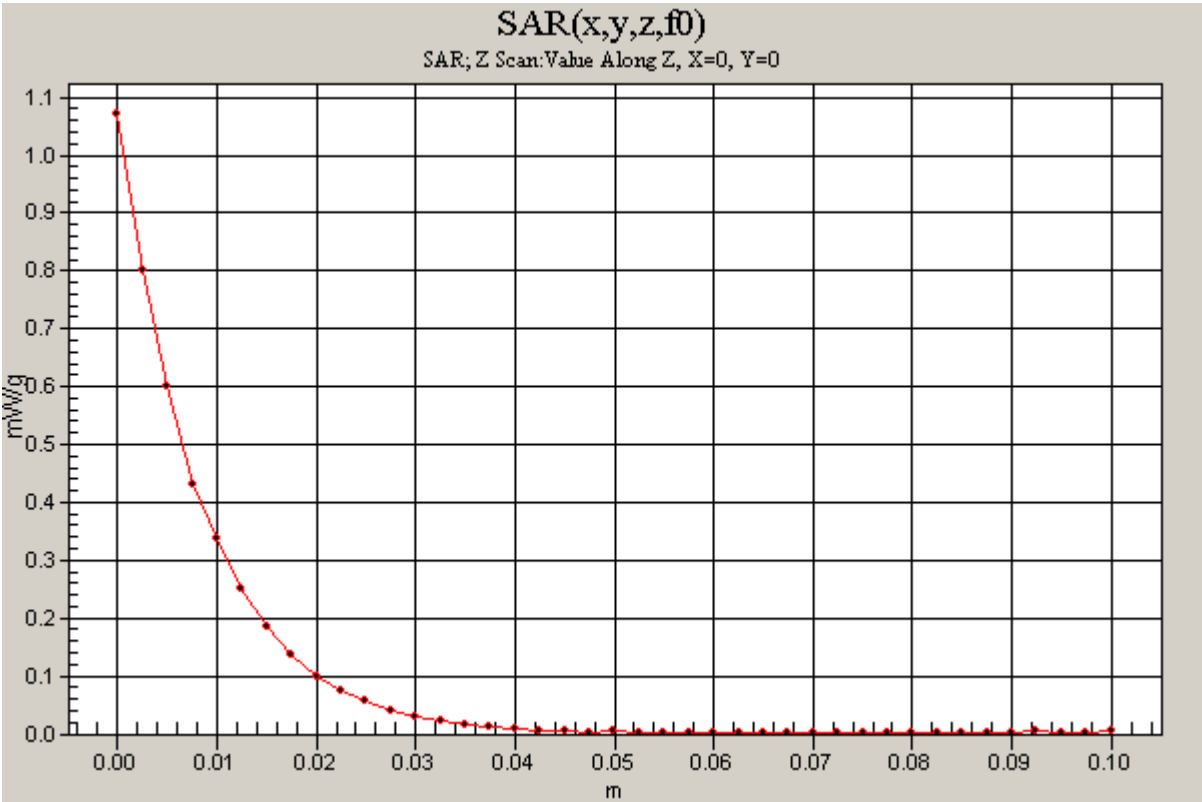

Test Laboratory: Compliance Certification Services

2_Host # 2_Dell Laptop

DUT: Airgo; Type: AGN1022PC-01; Serial: 6154W007931

Communication System: 802.11bg; Frequency: 2437 MHz; Duty Cycle: 1:1

Medium parameters used (interpolated): $f = 2437$ MHz; $\sigma = 1.98$ mho/m; $\epsilon_r = 51.8$; $\rho = 1000$ kg/m³

Phantom section: Flat Section

Room Ambient Temperature: 24 deg. C; Liquid Temperature: 23 deg. C

DASY4 Configuration:

- Area Scan setting - Find Secondary Maximum Within: 2.0 dB and with a peak SAR value greater than 0.0012W/kg
- Probe: EX3DV4 - SN3552 ; ConvF(6.94, 6.94, 6.94); Calibrated: 3/19/2005
- Sensor-Surface: 2.5mm (Mechanical Surface Detection)
- Electronics: DAE3 Sn500; Calibrated: 2/7/2005
- Phantom: SAM 2; Type: SAM 2; Serial: 1050
- Measurement SW: DASY4, V4.5 Build 19; Postprocessing SW: SEMCAD, V1.8 Build 146

g mode, M-ch (P: 20)/Area Scan (11x8x1): Measurement grid: dx=15mm, dy=15mm

[Info: Interpolated medium parameters used for SAR evaluation!](#)

Maximum value of SAR (measured) = 0.994 mW/g

g mode, M-ch (P: 20)/Zoom Scan (5x5x7)/Cube 0: Measurement grid: dx=7.5mm, dy=7.5mm, dz=5mm

Reference Value = 15.5 V/m; Power Drift = -0.169 dB

Peak SAR (extrapolated) = 1.32 W/kg

SAR(1 g) = 0.741 mW/g; SAR(10 g) = 0.401 mW/g

[Info: Interpolated medium parameters used for SAR evaluation!](#)

Maximum value of SAR (measured) = 0.968 mW/g

