

D-Puck

Model Number:
WID2452

Internal Antenna – Surface Mount

Specifications:

- Tape and reel packaging for high volume pick-and-place manufacturing processes
- Planar Inverted F Antenna (PIFA) requires ground plane to radiate efficiently

Frequency Ranges	2.4 - 2.5 GHz	5.15 - 5.875 GHz
Gain	>3 dBi	>4 dBi
Polarization	Linear	
Impedance	50 ohms	
VSWR	<2.5:1	
Dimensions (L x W x H)	16 x 16 x 6 mm	
Weight	2 g	
Carrier Material	Black color resin	

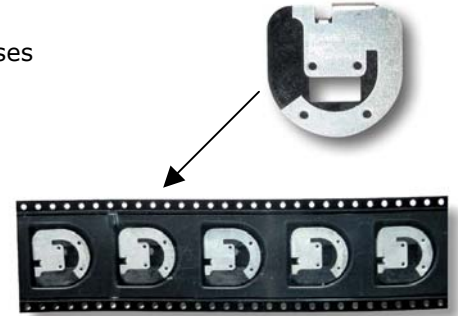

Connectors:

Model #	Part #	Description	Connector
WID2452	CAF94400	Tape and Reel	N/A
WID2452-SM	CAF94377	Eval PCBA	SMA-female Panel



Azimuth:
Total Gain

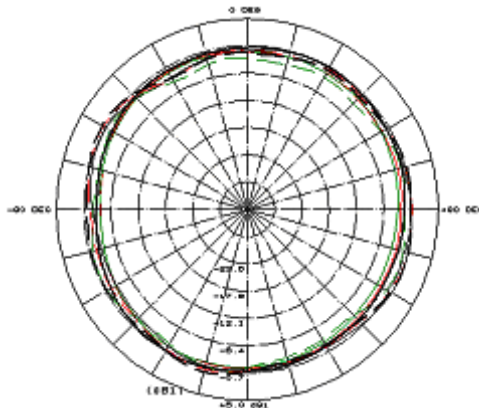

Elevation:
Total Gain

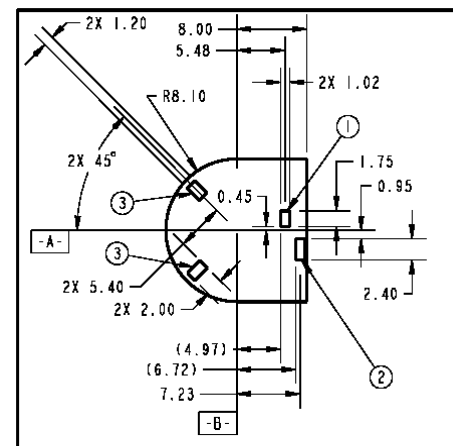
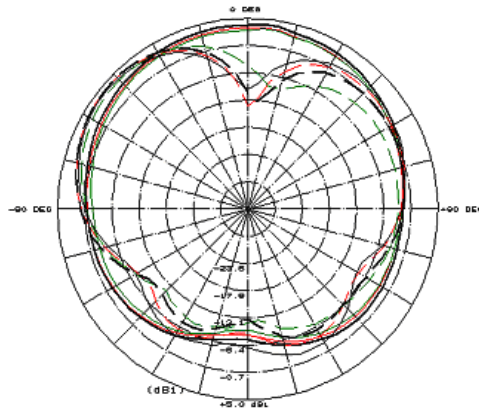

PCB FOOTPRINT LAYOUT

SCALE 2

VSWR

1. Feed pad. Provide 50-ohm signal to pad. Isolate feed pad from ground as required to provide 50-ohm signal at top mounting surface. Matching network components (Pi or L type) will be required on the input feed line.
2. Ground pad.

Specifications subject to change without notice.

D-Puck a - 5/7/04