



**FCC ID: S9QP202S**  
Issued on May 4, 2005

Report No.: FR533142

# FCC TEST REPORT

**CATEGORY** : Portable  
**PRODUCT NAME** : WIFI Phone  
**FCC ID.** : S9QP202S  
**FILING TYPE** : Certification  
**BRAND NAME** : ACT  
**MODEL NAME** : P202S, P202SU, P202SJ

**APPLICANT** : **ADVANTAGE CENTURY TELECOMMUNICATION CORP.**  
4F, NO.41, TUNG-SING RD., TAIPEI, TAIWAN, R.O.C.

**MANUFACTURER** : **Cameo Communications, Inc.**  
No.42, Section 6, Min-Chuan East Road, Taipei 114, Taiwan,  
R.O.C.

**ISSUED BY** : **SPORTON INTERNATIONAL INC.**  
6F, No. 106, Sec. 1, Hsin Tai Wu Rd., His Chih, Taipei Hsien,  
Taiwan, R.O.C.

## Statements:

The test result in this report refers exclusively to the presented test model / sample.  
Without written approval of SPORTON International Inc., the test report shall not be reproduced except in full.

Certificate or Test Report could not be used by the applicant to claim the product endorsement by CNLA and any agency of U.S. government.

The test equipment used to perform the test is calibrated and traceable to NML/ROC or NIST/USA.



1190  
ILAC MRA

**SPORTON International Inc.**

TEL : 886-2-2696-2468

FAX : 886-2-2696-2255



## Table of Contents

<b>HISTORY OF THIS TEST REPORT.....</b>	<b>II</b>
<b>CERTIFICATE OF COMPLIANCE.....</b>	<b>III</b>
<b>1. GENERAL DESCRIPTION OF EQUIPMENT UNDER TEST.....</b>	<b>1</b>
1.1. Applicant.....	1
1.2. Manufacturer.....	1
1.3. Basic Description of Equipment under Test.....	1
1.4. Features of Equipment under Test.....	1
1.5. Antenna Description.....	2
1.6. Table for Carrier Frequencies.....	2
<b>2. TEST CONFIGURATION OF THE EQUIPMENT UNDER TEST.....</b>	<b>3</b>
2.1. Connection Diagram of Test System.....	3
2.2. The Test Mode Description.....	3
2.3. Description of Test Supporting Units.....	4
<b>3. GENERAL INFORMATION OF TEST.....</b>	<b>5</b>
3.1. Test Facility.....	5
3.2. Standards for Methods of Measurement.....	5
3.3. DoC Statement.....	5
3.4. Frequency Range Investigated.....	5
3.5. Test Distance.....	5
3.6. Test Software.....	5
<b>4. LIST OF MEASUREMENTS.....</b>	<b>6</b>
4.1. Summary of the Test Results.....	6
<b>5. TEST RESULT.....</b>	<b>7</b>
5.1. Test of 6dB Spectrum Bandwidth.....	7
5.2. Test of Maximum Peak Conducted Output Power.....	10
5.3. Test of Peak Power Spectral Density.....	12
5.4. Test of Band Edges Emission.....	15
5.5. Test of AC Power Line Conducted Emission.....	19
5.6. Test of Spurious Radiated Emission.....	24
5.7. Antenna Requirements.....	38
5.8. RF Exposure.....	39
<b>6. LIST OF MEASURING EQUIPMENTS USED.....</b>	<b>41</b>
<b>7. COMPANY PROFILE.....</b>	<b>43</b>
7.1. Certificate of Accreditation.....	43
7.2. Test Location.....	43
<b>8. CNLA CERTIFICATE OF ACCREDITATION.....</b>	<b>44</b>
<b>APPENDIX A. PHOTOGRAPHS OF EUT.....</b>	<b>A1 ~ A10</b>





# CERTIFICATE OF COMPLIANCE

with

## 47 CFR FCC Part 15 Subpart C

**PRODUCT NAME** : WIFI Phone

**BRAND NAME** : ACT

**MODEL NAME** : P202S, P202SU, P202SJ

**APPLICANT** : **ADVANTAGE CENTURY TELECOMMUNICATION CORP.**  
4F, NO.41, TUNG-SING RD., TAIPEI, TAIWAN, R.O.C.

**MANUFACTURER** : **Cameo Communications, Inc.**  
No.42, Section 6, Min-Chuan East Road, Taipei 114, Taiwan,  
R.O.C.

I **HEREBY** CERTIFY THAT:

The measurements shown in this test report were made in accordance with the procedures given in ANSI C63.4-2003 and all test are performed according to 47 CFR FCC Part 15 Subpart C. Testing was carried out on Apr. 26th, 2005 at SPORTON International Inc. LAB.

A handwritten signature in blue ink, appearing to read 'Wayne Hsu', is written over a horizontal line.

**Wayne Hsu / Supervisor**  
Sporton International Inc.

## 1. General Description of Equipment under Test

### 1.1. Applicant

**ADVANTAGE CENTURY TELECOMMUNICATION CORP.**  
4F, NO.41, TUNG-SING RD., TAIPEI, TAIWAN, R.O.C.

### 1.2. Manufacturer

**Cameo Communications, Inc.**  
No.42, Section 6, Min-Chuan East Road, Taipei 114, Taiwan, R.O.C.

### 1.3. Basic Description of Equipment under Test

This product is a Wireless LAN VoIP phone with 802.11b wireless solution. The technical data has been listed on section " Features of Equipment under Test ".

### 1.4. Features of Equipment under Test

Items	Description
Type of Modulation	DSSS (CCK / DQPSK / DBPSK)
Number of Channels	11
Frequency Band	2400 MHz ~ 2483.5 MHz
Carrier Frequency	See section 1.6 for details
Data Rate	1, 2, 5.5, 11 Mbps
Max. Conducted Output Power	16.00 dBm
Antenna Type	See section 1.5 for details
Communication Type	Half-Duplex
Testing Duty Cycle	100.00%
Test Power Source	5V DC from power adapter ; Rechargeable Battery
Temperature Range (Operating)	0 ~ 40 °C



### 1.5. Antenna Description

No.	Antenna Type	Gain (dBi)
1	Chip Antenna	2.50

### 1.6. Table for Carrier Frequencies

Channel	Frequency	Channel	Frequency	Channel	Frequency	Channel	Frequency
01	2412 MHz	05	2432 MHz	09	2452 MHz	-	-
02	2417 MHz	06	2437 MHz	10	2457 MHz	-	-
03	2422 MHz	07	2442 MHz	11	2462 MHz	-	-
04	2427 MHz	08	2447 MHz	-	-	-	-

## 2. Test Configuration of the Equipment under Test

### 2.1. Connection Diagram of Test System

#### Normal Mode

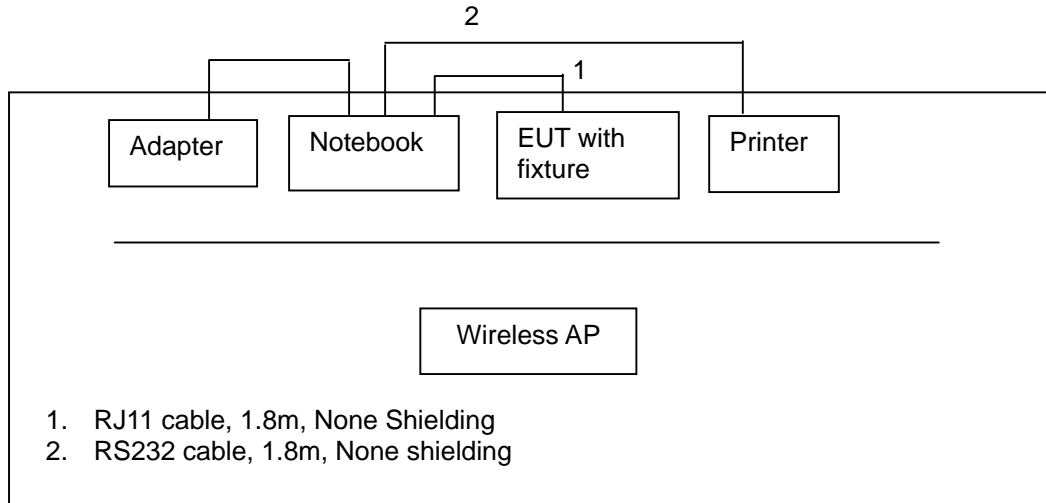

#### Charging Mode

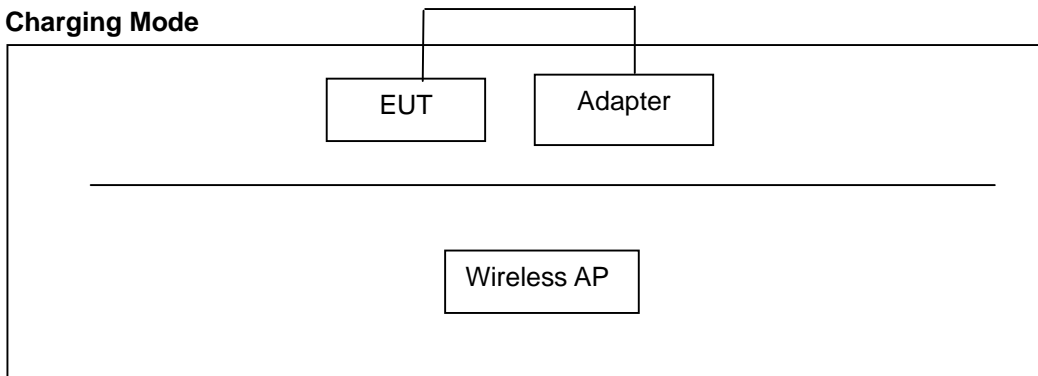

### 2.2. The Test Mode Description

1. For DSSS modulation, CCK (11 Mbps) is the worst case on all test items.
2. According to ANSI C63.4-2003: If frequency range of EUT is more than 10 MHz, we have to test the lowest, middle and highest channels of EUT.
3. Spurious emission below 1GHz is independent of channel selection and modulation types. So only channel 06 with DSSS modulation was tested.
4. AC conduction emission is independent of channel selection and modulation types. So only channel 06 with DSSS modulation was tested.
5. The following test modes were performed for radiated spurious emission below 1GHz:  
Mode 1: Normal Mode  
Mode 2: Charging Mode



### 2.3. Description of Test Supporting Units

Support unit	Brand	Model No.	FCC ID	Data cable (m)
Fixture	BALANCE	GPSS-0500200	-	-
AP	3COM	AP2750	O9C-AP2750	NA
Printer	EPSON	LQ-300	DoC	1.35
Notebook	DELL	PP01L	DoC	NA





### 3. General Information of Test

#### 3.1. Test Facility

**Test Site Location** : No. 52, Hwa Ya 1st Rd., Hwa Ya Technology Park, Kwei-Shan Hsiag, Tao Yuan Hsien, Taiwan, R.O.C.  
: TEL 886-3-327-3456  
: FAX 886-3-318-0055

**Test Site No** : 03CH03-HY / TH01-HY / CO01-HY

#### 3.2. Standards for Methods of Measurement

Here is the list of the standards followed in this test report.

**ANSI C63.4-2003**  
**47 CFR FCC Part 15 Subpart C**

#### 3.3. DoC Statement

This EUT is also classified as a device of computer peripheral Class B which DoC has to be followed. It has been verified according to the rule of 47 CFR part 15 Subpart B, and found that all the requirements has been fulfilled.

#### 3.4. Frequency Range Investigated

Radiated emission test: from 30 MHz to 10th carrier harmonic

#### 3.5. Test Distance

The test distance of radiated emission (30MHz~1GHz) test from antenna to EUT is 3 M.  
The test distance of radiated emission (1GHz~10th carrier harmonic) test from antenna to EUT is 3 M.

#### 3.6. Test Software

Executed "RTS 2.04" to keep transmitting signals at fixed frequency.

##### Power Parameter Table

Test Software	RTS 2.04
Power Set CH 01 / CCK	Default / TX Power
Power Set CH 06 / CCK	Default / TX Power
Power Set CH 11 / CCK	Default / TX Power



## 4. List of Measurements

### 4.1. Summary of the Test Results

Applied Standard: 47 CFR FCC Part 15 Subpart C			
Paragraph	FCC Section	Description of Test	Result
5.1	15.247(a)(2)	6dB Spectrum Bandwidth	Pass
5.2	15.247(b)(3)	Maximum Peak Conducted Output Power	Pass
5.3	15.247(e)	Peak Power Spectral Density	Pass
5.4	15.247(d)	Band Edges Emission	Pass
5.5	15.207	AC Power Line Conducted Emission	Pass
5.6	15.247(d)	Spurious Radiated Emission	Pass
5.7	15.203/15.247(b)/(c)	Antenna Requirement	Pass
5.8	2.1091	Maximum Permissible Exposure	Pass

## 5. Test Result

### 5.1. Test of 6dB Spectrum Bandwidth

#### 5.1.1. Applicable Standard

Section 15.247(a)(2): For digital modulation systems, the minimum 6 dB bandwidth shall be at least 500 kHz.

#### 5.1.2. Measuring Instruments

Item 18 of the table on section 6.

#### 5.1.3. Description of Major Test Instruments Setting

- Spectrum Analyzer : R&S FSP30
- Attenuation : Auto
- Center Frequency : 2412 MHz / 2437 MHz / 2462 MHz
- Span Frequency : > 6dB Bandwidth
- RB : 100 kHz
- VB : 100 kHz
- Detector : Peak
- Trace : Max Hold
- Sweep Time : Auto

#### 5.1.4. Test Procedures

1. The transmitter output was connected to the spectrum analyzer through an attenuator.
2. Set RBW of spectrum analyzer to 100KHz and VBW to 100KHz. Trace to Max hold and Detector PK.
3. The 6dB bandwidth is the spectrum width is the bandwidth with level higher than 6dB below the peak level.
4. Repeat above point 1~3 for the middle and highest channel of the EUT.

#### 5.1.5. Test Setup Layout

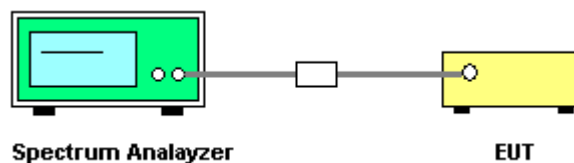

#### 5.1.6. Test Criteria

All test results complied with the requirements of 15.247(a)(2). Measurement Uncertainty is  $1 \times 10^{-5}$ .



5.1.7. Test Result

- Temperature: 16°C
- Relative Humidity: 60%
- Duty Cycle of the Equipment During the Test: 100.00%
- Test Engineer: Steven Lu

Modulation Type	Channel No.	Frequency (MHz)	6dB Bandwidth (MHz)	Min. Limit (MHz)
DSSS	01	2412 MHz	10.12	0.5
DSSS	06	2437 MHz	10.08	0.5
DSSS	11	2462 MHz	10.12	0.5

Modulation Type: DSSS (Channel 01) :

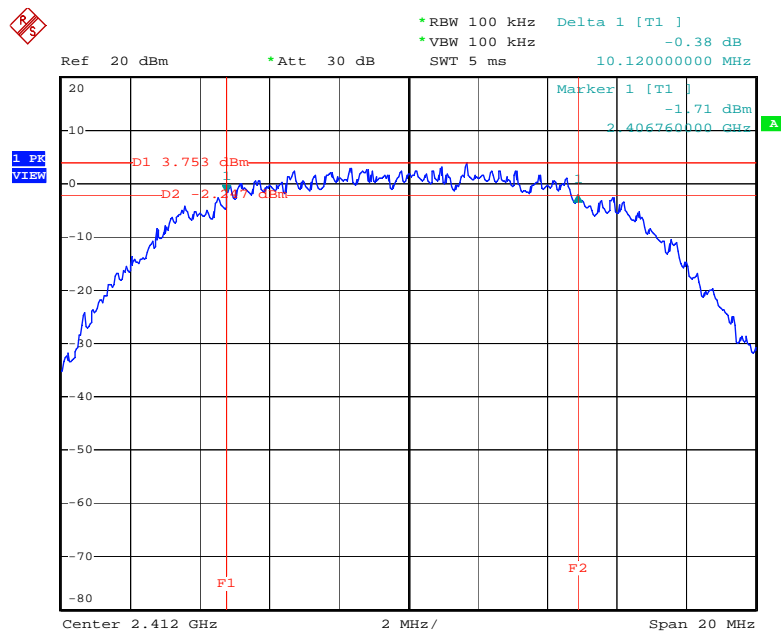

Date: 21.APR.2005 09:49:30



Modulation Type: DSSS (Channel 06) :

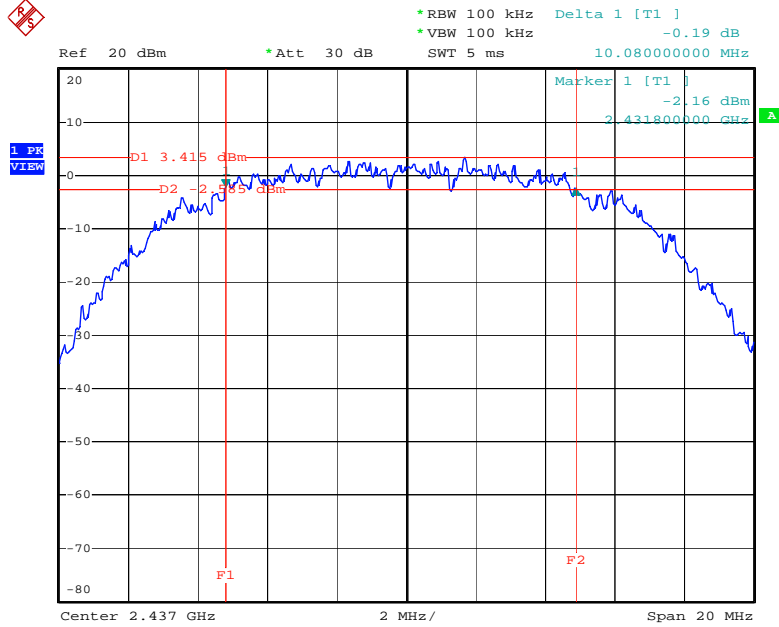

Date: 21.APR.2005 09:48:42

Modulation Type: DSSS (Channel 11) :

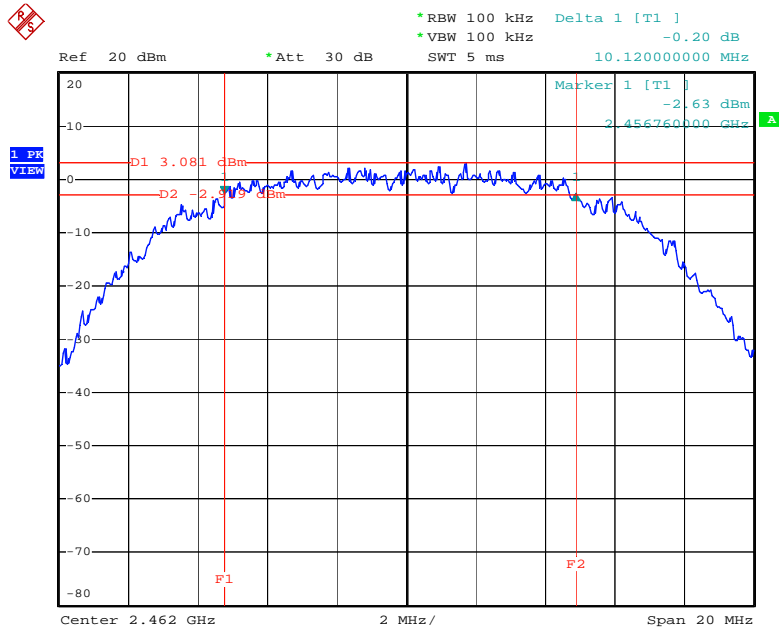

Date: 21.APR.2005 09:47:29

## 5.2. Test of Maximum Peak Conducted Output Power

### 5.2.1. Applicable Standard

Section 15.247(b)(3): The maximum peak output power shall not exceed 1 watt (30dBm). Except as shown below, if transmitting antennas of directional gain greater than 6 dBi are used the peak output power from the intentional radiator shall be reduced below the above stated values by the amount in dB that the directional gain of the antenna exceeds 6 dBi.

### 5.2.2. Measuring Instruments

Item 19, 21 of the table on section 6.

### 5.2.3. Test Procedures and Test Instruments Setting

1. The transmitter output was connected to the peak power meter through an attenuator.
2. Repeated point 1 for the middle and highest channel of the EUT.

### 5.2.4. Test Setup Layout

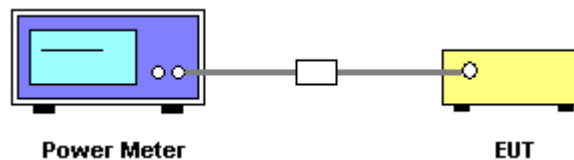

### 5.2.5. Test Criteria

All test results complied with the requirements of 15.247(b)(3). Measurement Uncertainty is 1.5dB.



5.2.6. Test Result of Conducted Power

- Temperature: 16°C
- Relative Humidity: 60%
- Duty Cycle of the Equipment During the Test: 100.00%
- Test Engineer: Steven Lu

Modulation Type	Channel No.	Frequency (MHz)	Output Power (dBm)	Limits (dBm)
DSSS	01	2412 MHz	16.00	30
DSSS	06	2437 MHz	15.50	30
DSSS	11	2462 MHz	15.00	30

5.2.7. Test Result of EIRP Power

- Temperature: 16°C
- Relative Humidity: 60%
- Duty Cycle of the Equipment During the Test: 100.00%
- Test Engineer: Steven Lu

Antenna No.	Gain (dBi)	Modulation Type	Channel No.	Frequency (MHz)	Power (dBm)	Limits (dBm)
1	2.50	DSSS	01	2412 MHz	18.50	36
1	2.50	DSSS	06	2437 MHz	18.00	36
1	2.50	DSSS	11	2462 MHz	17.50	36

### 5.3. Test of Peak Power Spectral Density

#### 5.3.1. Applicable Standard

Section 15.247(e): For digital modulation systems, the peak power spectral density conducted from the intentional radiator to the antenna shall not be greater than 8 dBm in any 3 kHz band during any time interval of continuous transmission.

#### 5.3.2. Measuring Instruments

Item 18 of the table on section 6.

#### 5.3.3. Description of Major Test Instruments Setting

- Spectrum Analyzer : R&S FSP30
- Attenuation : Auto
- Center Frequency : 2412 MHz / 2437 MHz / 2462 MHz
- Span Frequency : 1.5MHz
- RB : 3 kHz
- VB : 30 kHz
- Detector : Peak
- Trace : Max Hold
- Sweep Time : 500s

#### 5.3.4. Test Procedures

1. The transmitter output is connected to the spectrum analyzer through an attenuator.
2. Set RBW of spectrum analyzer to 3kHz and VBW to 30kHz. Set Detector to Peak, Trace to Max Hold.
3. Mark the frequency with maximum peak power as the center of the display of the spectrum.
4. Set the span to 1.5MHz and the sweep time to 500s and record the maximum peak value.
5. Repeated point 1~4 for the middle and highest channel of the EUT.

#### 5.3.5. Test Setup Layout

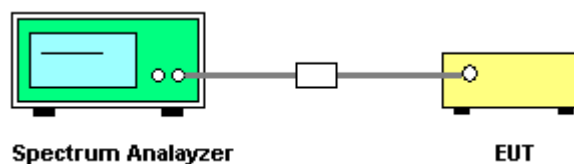

#### 5.3.6. Test Criteria

All test results complied with the requirements of 15.247(e). Measurement Uncertainty is 1.5dB.





5.3.7. Test Result

- Temperature: 16°C
- Relative Humidity: 60%
- Duty Cycle of the Equipment During the Test: 100.00%
- Test Engineer: Steven Lu

Modulation Type	Channel No.	Frequency (MHz)	Power Density (dBm)	Limits (dBm)
DSSS	01	2412 MHz	-8.88	8
DSSS	06	2437 MHz	-9.21	8
DSSS	11	2462 MHz	-9.64	8

Modulation Type: DSSS (Channel 01) :

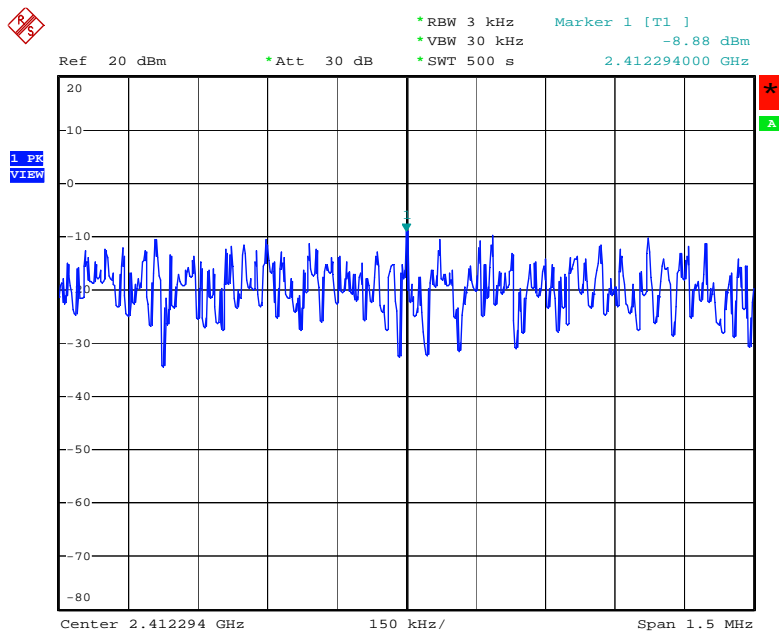

Date: 21.APR.2005 09:49:55



Modulation Type: DSSS (Channel 06) :

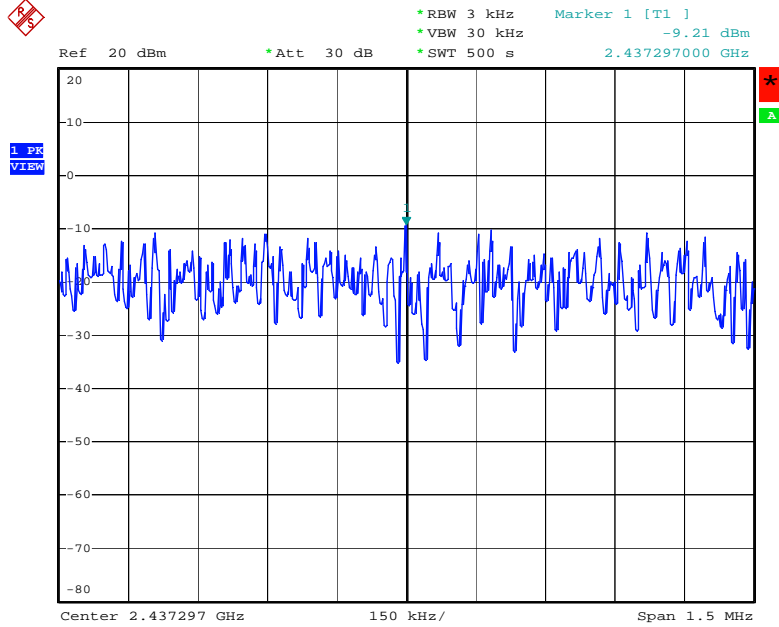

Date: 21.APR.2005 09:48:58

Modulation Type: DSSS (Channel 11) :

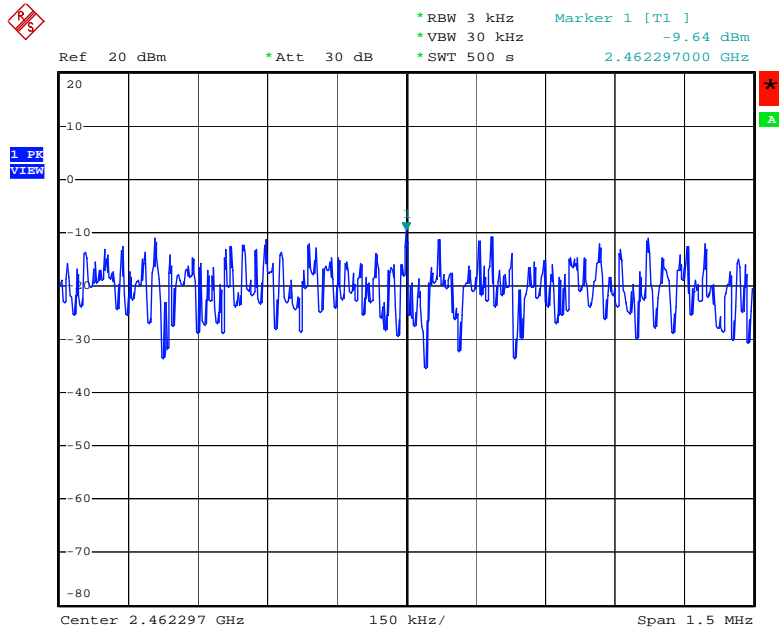

Date: 21.APR.2005 09:47:44

## 5.4. Test of Band Edges Emission

### 5.4.1. Applicable Standard

Section 15.247(d): In any 100 kHz bandwidth outside the frequency band in which the spread spectrum or digitally modulated intentional radiator is operating, the radio frequency power that is produced by the intentional radiator shall be at least 20 dB below that in the 100 kHz bandwidth within the band that contains the highest level of the desired power, based on either an RF conducted or a radiated measurement. In addition, radiated emissions that fall in the restricted bands, as defined in Section 15.205, must also comply with the radiated emission limits specified in Section 15.209.

### 5.4.2. Measuring Instruments

Item 6~17 of the table on section 6 for radiated measurement.

Item 18 of the table on section 6 for conducted measurement.

### 5.4.3. Description of Major Test Instruments Setting

- Spectrum Analyzer : R&S FSP30 (Conducted Measurement)
  - Attenuation : Auto
  - Center Frequency : 2412 MHz / 2462 MHz
  - Span Frequency : 100MHz
  - RB : 100 kHz
  - VB : 100 kHz
  - Detector : Peak
  - Trace : Max Hold
  - Sweep Time : Auto
  
- Spectrum Analyzer : R&S FSP40 (Radiated Measurement)
  - Attenuation : Auto
  - Center Frequency : 2412 MHz / 2462 MHz
  - Span Frequency : 100MHz
  - RB : 1 MHz for PK value / 1 MHz for AV value
  - VB : 1 MHz for PK value / 10 Hz for AV value
  - Detector : Peak
  - Trace : Max Hold
  - Sweep Time : Auto

### 5.4.4. Test Procedures and Test Instruments Setting

#### Conducted Measurement

1. The transmitter is set to the lowest channel.
2. The transmitter output was connected to the spectrum analyzer via a cable and cable loss is used as the offset of the spectrum analyzer.
3. Set both RBW and VBW of spectrum analyzer to 100KHz with convenient frequency span including 100MHz bandwidth from lower band edge. Then detector set to peak and max hold this trace.
4. The lowest band edges emission was measured and recorded.
5. The transmitter set to the highest channel and repeated point 2~4.

**Radiated Measurement**

1. Configure the EUT according to ANSI C63.4-2003.
2. The turntable was rotated by 360 degrees to determine the position of the highest radiation.
3. The height of the broadband receiving antenna was varied between one meter and four meters above ground to find the maximum emission field strength of both horizontal and vertical polarization.
4. For band edge emission, the antenna tower was scan (from 1 M to 4 M) and then the turn table was rotated (from 0 degree to 360 degrees) to find the maximum reading.
5. For band edge emission in restriction bands, use 10Hz VBW and 1MHz RBW for reading under AV and use 1MHz VBW and 1 MHz RBW for reading under PK.

5.4.5. Test Setup

**Radiated Method**

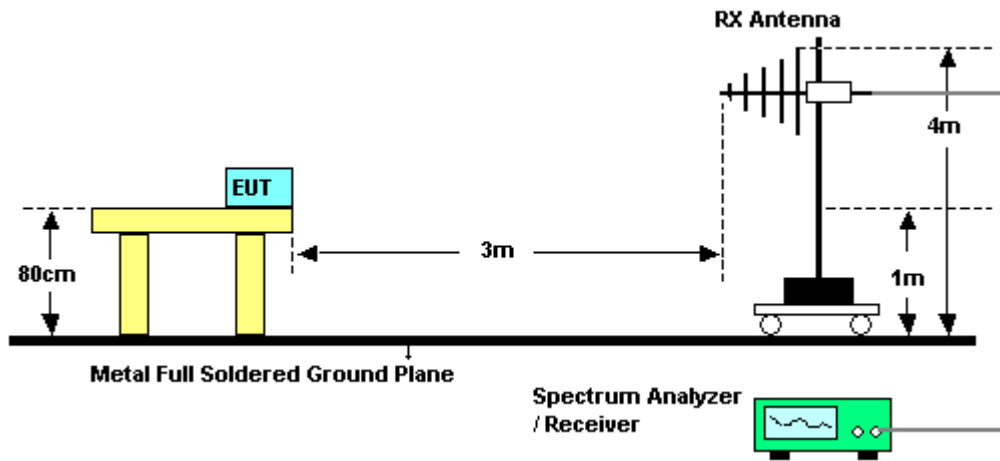

**Conducted Method**

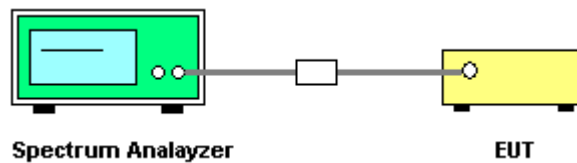

5.4.6. Test Criteria

All test results complied with the requirements of 15.247(d). Measurement Uncertainty is  $1 \times 10^{-5}$ .



5.4.7. Test Result of Radiated Emission

- Temperature: 16°C
- Relative Humidity: 60%
- Duty Cycle of the Equipment During the Test: 100.00%
- Test Engineer: Steven Lu

Modulation Type	Test Channel	Freq. (MHz)	Level* (dBuV/m)	Margin (dB)	Limit (dBuV/m)	Trace (PK/AV)
DSSS	01	2390.00	60.72	-13.28	74	PK
DSSS	01	2390.00	51.37	-2.63	54	AV
DSSS	11	2483.50	57.56	-16.44	74	PK
DSSS	11	2483.50	48.89	-5.11	54	AV

Level\*: The max field strength in the restricted bands.

5.4.8. Test Result of Conducted Emission

Modulation Type: DSSS (Channel 01) :

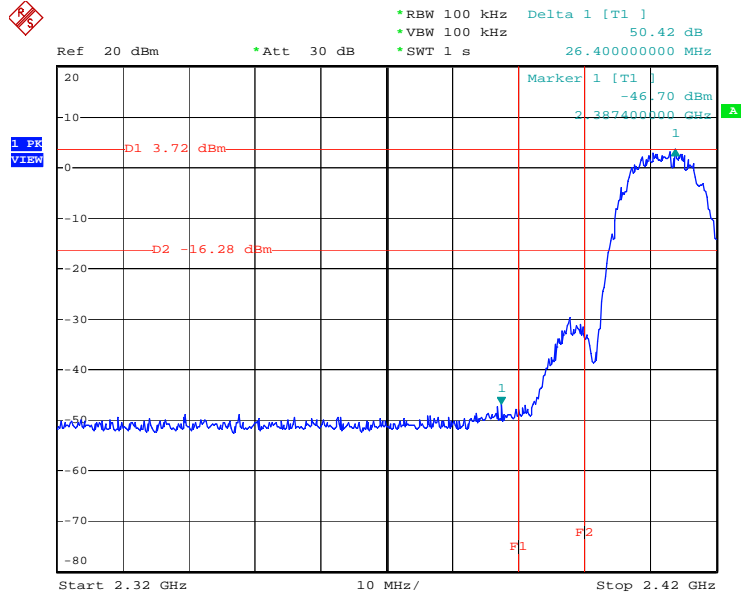

Date: 21.APR.2005 09:50:03

Modulation Type: DSSS (Channel 11) :

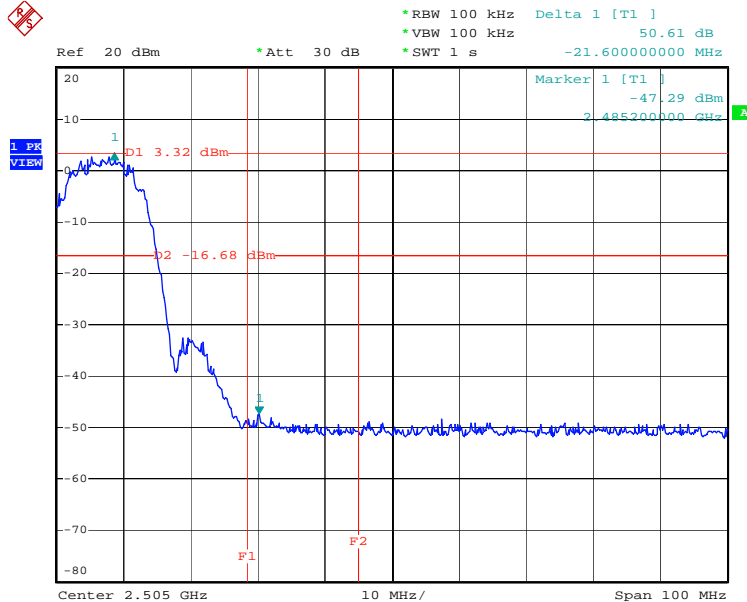

Date: 25.APR.2005 09:34:33

## 5.5. Test of AC Power Line Conducted Emission

### 5.5.1. Applicable Standard

Section 15.207: For a Low-power Radio-frequency Device is designed to be connected to the AC power line, the radio frequency voltage that is conducted back onto the AC power line on any frequency or frequencies within the band 150 kHz to 30 MHz shall not exceed below limits table.

Frequency (MHz)	QP Limit (dBuV)	AV Limit (dBuV)
0.15~0.5	66~56	56~46
0.5~5	56	46
5~30	60	50

### 5.5.2. Measuring Instruments

Please reference item 1~5 in chapter 6 for the instruments used for testing.

### 5.5.3. Description of Major Test Instruments Setting

- Test Receiver : R&S ESCS 30
- Attenuation : 10 dB
- Start Frequency : 0.15 MHz
- Stop Frequency : 30 MHz
- IF Bandwidth : 9 KHz

### 5.5.4. Test Procedures

1. Configure the EUT according to ANSI C63.4-2003.
2. The EUT has to be placed 0.4 meter far from the conducting wall of the shielding room and at least 80 centimeters from any other grounded conducting surface.
3. Connect EUT to the power mains through a line impedance stabilization network (LISN)
4. All the support units are connected to the other LISNs. The LISN should provide 50uH/ 50ohms coupling impedance.
5. The frequency range from 150 KHz to 30 MHz was searched.
6. Use the Channel & Power Controlling software to make the EUT working on selected channel and expected output power, then use the "H" Patter Generator software to make the supporting equipments stay on working condition.
7. Set the test-receiver system to Peak Detect Function and Specified Bandwidth with Maximum Hold Mode.
8. The measurement has to be done between each power line and ground at the power terminal for each RF channel. Only one RF channel has to be investigated since this test is independent with the RF channel selection.

### 5.5.5. Test Setup Layout

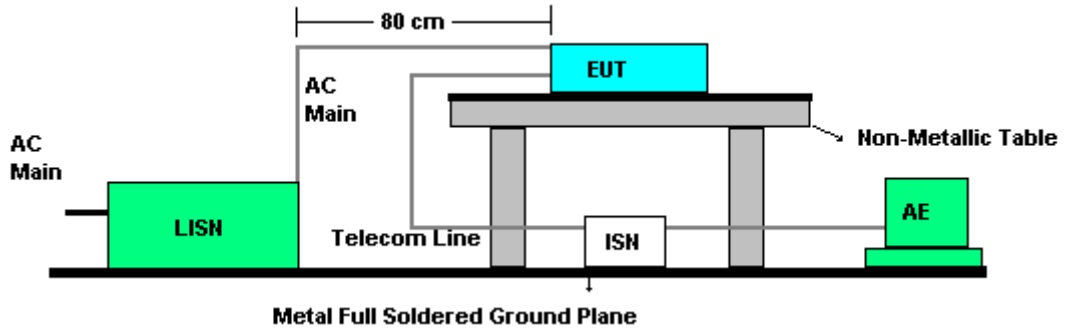

### 5.5.6. Test Criteria

All test results complied with the requirements of 15.207. Measurement Uncertainty is 2.54dB.





5.5.7. Test Result of Conducted Emission for CH 06 / 2437 MHz

- Modulation Type: DSSS
- Temperature: 16°C
- Relative Humidity: 60%
- Test Engineer: Steven Lu

**Line to Ground**

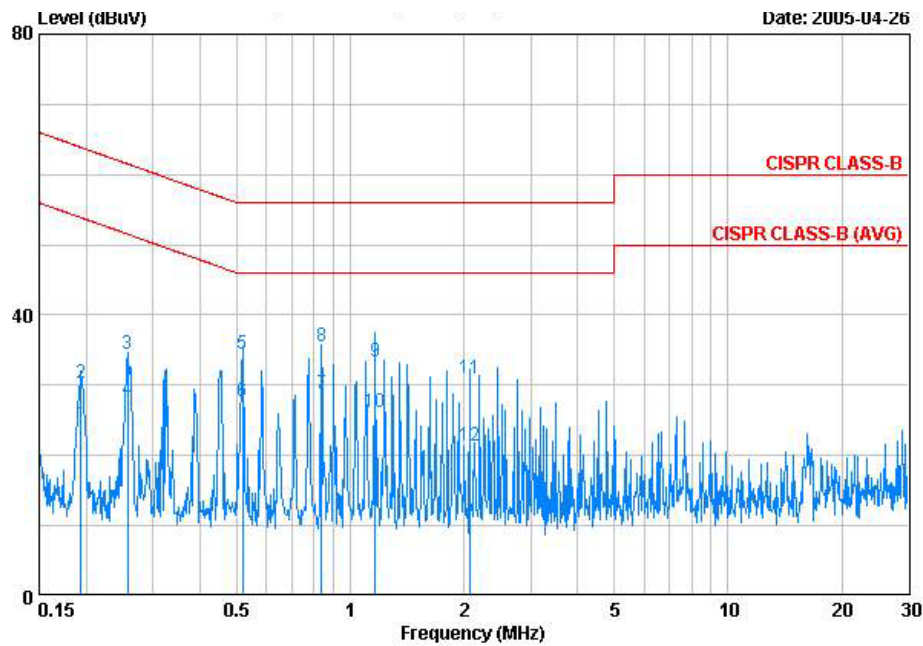

	Freq	Level	Over	Limit	Read	LISN	Cable	Remark
	MHz	dBuV	Limit	Line	Level	Factor	Loss	
			dB	dBuV	dBuV	dB	dB	
1	0.19344	24.34	-29.55	53.89	24.02	0.20	0.12	AVERAGE
2	0.19344	30.28	-33.61	63.89	29.96	0.20	0.12	QP
3	0.25751	34.42	-27.09	61.51	34.26	0.16	0.00	QP
4	0.25751	27.86	-23.65	51.51	27.70	0.16	0.00	AVERAGE
5	0.51824	34.39	-21.61	56.00	34.29	0.10	0.00	QP
6	0.51824	27.79	-18.21	46.00	27.69	0.10	0.00	AVERAGE
7	0.83932	28.71	-17.29	46.00	28.61	0.10	0.00	AVERAGE
8	0.83932	35.56	-20.44	56.00	35.46	0.10	0.00	QP
9	1.166	33.39	-22.61	56.00	33.27	0.10	0.02	QP
10	1.166	26.14	-19.86	46.00	26.02	0.10	0.02	AVERAGE
11	2.066	31.05	-24.95	56.00	30.85	0.10	0.10	QP
12	2.066	21.45	-24.55	46.00	21.25	0.10	0.10	AVERAGE



**Neutral to Ground**

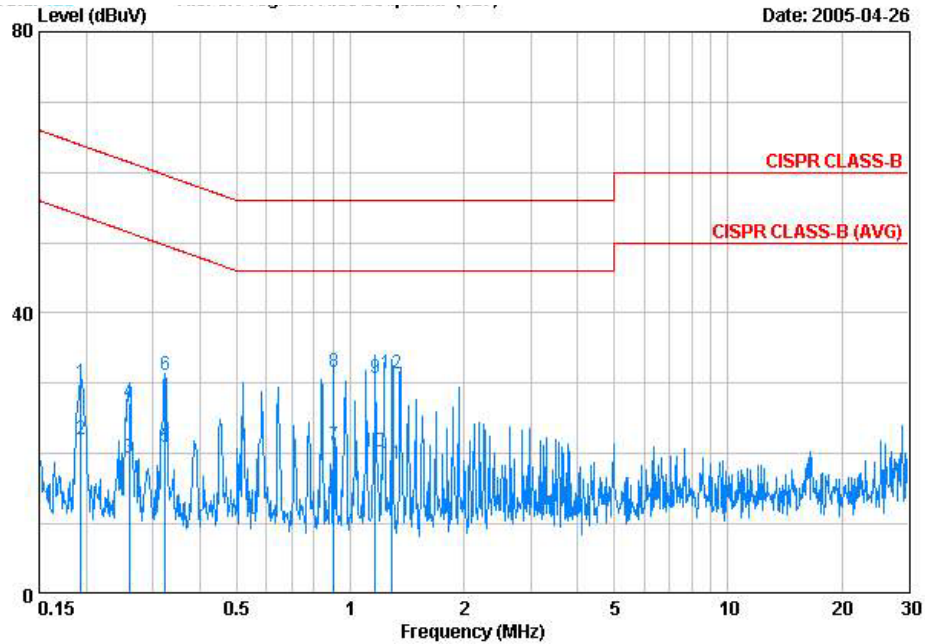

	Freq	Level	Over	Limit	Read	LISN	Cable	Remark
	MHz	dBuV	Limit	Line	Level	Factor	Loss	
			dB	dBuV	dBuV	dB	dB	
1	0.19344	30.01	-33.87	63.89	29.68	0.21	0.12	QP
2	0.19344	22.04	-31.84	53.89	21.71	0.21	0.12	AVERAGE
3	0.26026	19.29	-32.13	51.42	19.13	0.16	0.00	AVERAGE
4	0.26026	27.34	-34.08	61.42	27.18	0.16	0.00	QP
5	0.32340	21.02	-28.60	49.62	20.89	0.13	0.00	AVERAGE
6	0.32340	31.11	-28.51	59.62	30.98	0.13	0.00	QP
7	0.90394	21.15	-24.85	46.00	21.05	0.10	0.00	AVERAGE
8	0.90394	31.51	-24.49	56.00	31.41	0.10	0.00	QP
9	1.166	30.66	-25.34	56.00	30.54	0.10	0.02	QP
10	1.166	20.23	-25.77	46.00	20.11	0.10	0.02	AVERAGE
11	1.289	18.64	-27.36	46.00	18.50	0.10	0.04	AVERAGE
12	1.289	31.46	-24.54	56.00	31.32	0.10	0.04	QP

Note:

Corrected Reading: Probe (LISN / ISN) Factor + Cable Loss + Read Level = Level.

5.5.8. Photographs of Conducted Emission Test Configuration

FRONT VIEW



REAR VIEW





## 5.6. Test of Spurious Radiated Emission

### 5.6.1. Applicable Standard

Section 15.247(d): In any 100 kHz bandwidth outside the frequency band in which the spread spectrum or digitally modulated intentional radiator is operating, the radio frequency power that is produced by the intentional radiator shall be at least 20 dB below that in the 100 kHz bandwidth within the band that contains the highest level of the desired power, based on either an RF conducted or a radiated measurement. In addition, radiated emissions that fall in the restricted bands, as defined in Section 15.205, must also comply with the radiated emission limits specified in Section 15.209.

### 5.6.2. Measuring Instruments

Please reference item 1~17 in chapter 6 for the instruments used for testing.

### 5.6.3. Description of Major Test Instruments Setting

- Spectrum Analyzer : R&S FSP40
  - Attenuation : Auto
  - Start Frequency : 1000 MHz
  - Stop Frequency : 10th carrier harmonic
  - RB / VB : 1 MHz / 1MHz for Peak
  - RB / VB : 1 MHz / 10Hz for Average
  
- Test Receiver : R&S ESCS 30
  - Attenuation : Auto
  - Start Frequency : 30 MHz
  - Stop Frequency : 1000 MHz
  - RB : 120 KHz for QP or PK

### 5.6.4. Test Procedures

1. Configure the EUT according to ANSI C63.4-2003.
2. The EUT was placed on the top of the turntable 0.8 meter above ground.
3. The phase center of the receiving antenna mounted on the top of a height-variable antenna tower was placed 3 meters far away from the turntable.
4. Power on the EUT and all the supporting units.
5. The turntable was rotated by 360 degrees to determine the position of the highest radiation.
6. The height of the broadband receiving antenna was varied between one meter and four meters above ground to find the maximum emission field strength of both horizontal and vertical polarization.
7. For each suspected emission, the antenna tower was scan (from 1 M to 4 M) and then the turntable was rotated (from 0 degree to 360 degrees) to find the maximum reading.
8. Set the test-receiver system to Peak or CISPR quasi-peak Detect Function with specified bandwidth under Maximum Hold Mode.
9. For emission above 1GHz, use 1MHz VBW and RBW for peak reading. Then 1MHz RBW and 10Hz VBW for average reading in spectrum analyzer.

10. If the emission level of the EUT in peak mode was 3 dB lower than the average limit specified, then testing will be stopped and peak values of EUT will be reported, otherwise, the emissions which do not have 3 dB margin will be repeated one by one using the quasi-peak method for below 1GHz and average method for above the 1GHz. the reported.
11. For testing above 1GHz, the emission level of the EUT in peak mode was 20dB higher than average limit (that means the emission level in peak mode also complies with the limit in average mode), then testing will be stopped and peak values of EUT will be reported, otherwise, the emissions will be measured in average mode again and reported.

#### 5.6.5. Test Setup Layout

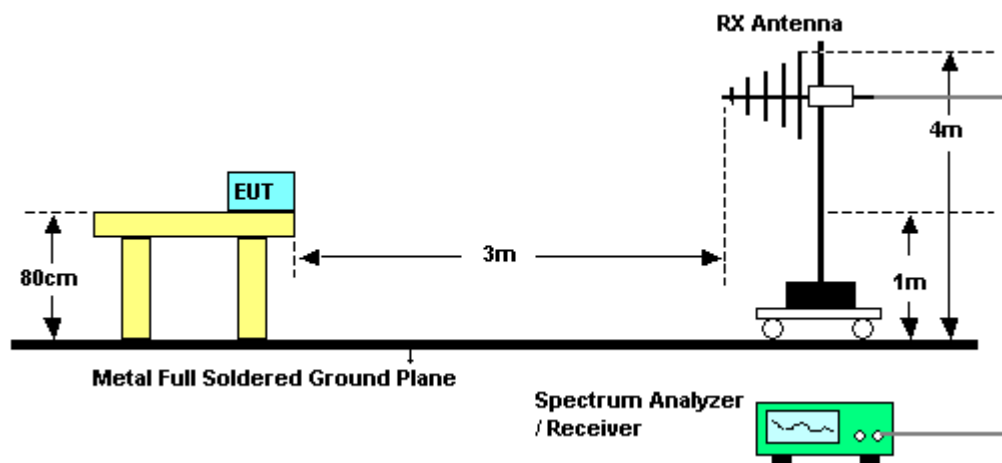

#### 5.6.6. Test Criteria

All test results complied with the requirements of 15.247(d). Measurement Uncertainty is 2.26dB.



5.6.7. Test Results for CH 06 / 2437 MHz (for emission below 1GHz)

- Test Mode: 1
- Modulation Type: DSSS
- Temperature: 16°C
- Relative Humidity: 60%
- Duty Cycle of the Equipment During the Test: 100.00%
- Test Engineer: Steven Lu

**(A) Polarization: Horizontal**

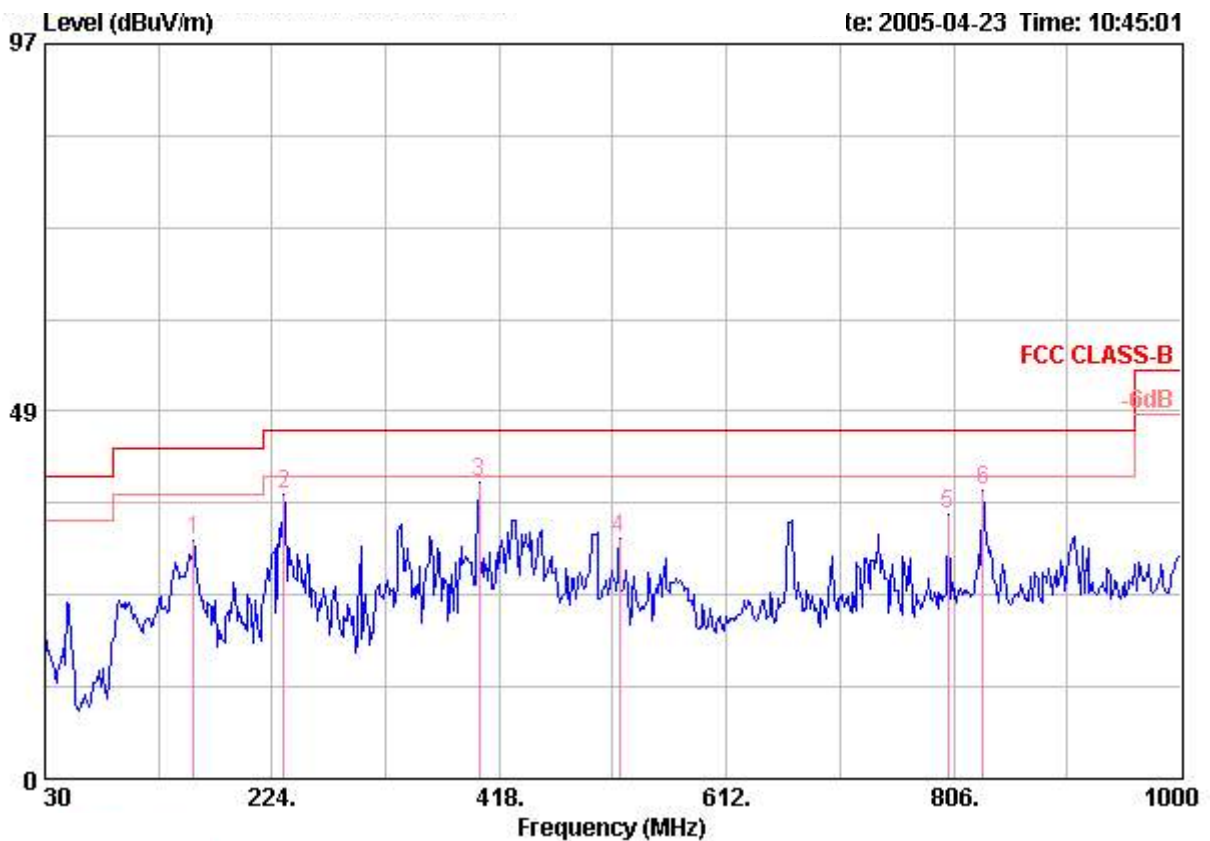

	Freq	Level	Over Limit	Limit	Antenna Line Factor	Cable Loss	Preamplifier Factor	Read Level	Pol/Phase	Remark
	MHz	dBuV/m	dB	dBuV/m	dB/m	dB	dB	dBuV		
1	157.070	31.40	-12.10	43.50	9.66	1.00	30.14	50.88	HORIZONTAL	Peak
2	233.700	37.46	-8.54	46.00	10.26	1.21	30.07	56.06	HORIZONTAL	Peak
3 @	400.540	39.14	-6.86	46.00	15.94	1.59	30.35	51.96	HORIZONTAL	Peak
4	520.820	31.59	-14.41	46.00	17.70	1.81	30.57	42.65	HORIZONTAL	Peak
5	801.150	34.98	-11.02	46.00	20.01	2.26	30.13	42.84	HORIZONTAL	Peak
6	831.220	38.04	-7.96	46.00	20.30	2.32	30.02	45.43	HORIZONTAL	Peak



**(B) Polarization: Vertical**

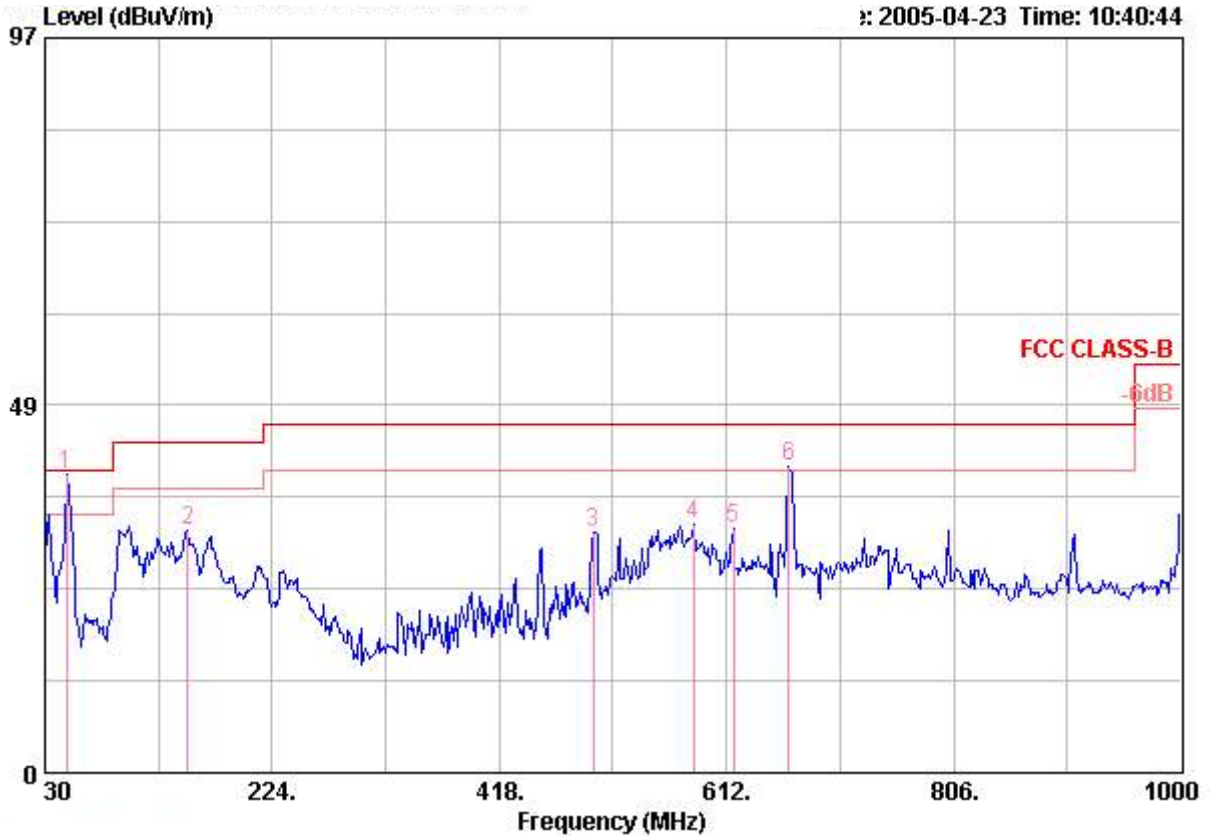

	Freq	Level	Over	Limit	Antenna	Cable	Preamp	Read	Pol/Phase	Remark
	MHz	dBuV/m	dB	dBuV/m	dB/m	dB	dB	dBuV		
1 @	48.430	39.28	-0.72	40.00	8.50	0.59	29.83	60.02	VERTICAL	Peak
2	152.220	32.08	-11.42	43.50	9.94	0.98	30.11	51.27	VERTICAL	Peak
3	498.510	31.64	-14.36	46.00	17.36	1.77	30.53	43.05	VERTICAL	Peak
4	583.870	32.66	-13.34	46.00	18.66	1.90	30.80	42.90	VERTICAL	Peak
5	617.820	32.33	-13.67	46.00	18.71	1.96	30.68	42.34	VERTICAL	Peak
6 @	665.350	40.37	-5.63	46.00	18.91	2.06	30.35	49.76	VERTICAL	Peak



- Test Mode: 2
- Modulation Type: DSSS
- Temperature: 16°C
- Relative Humidity: 60%
- Duty Cycle of the Equipment During the Test: 100.00%
- Test Engineer: Steven Lu

**(A) Polarization: Horizontal**

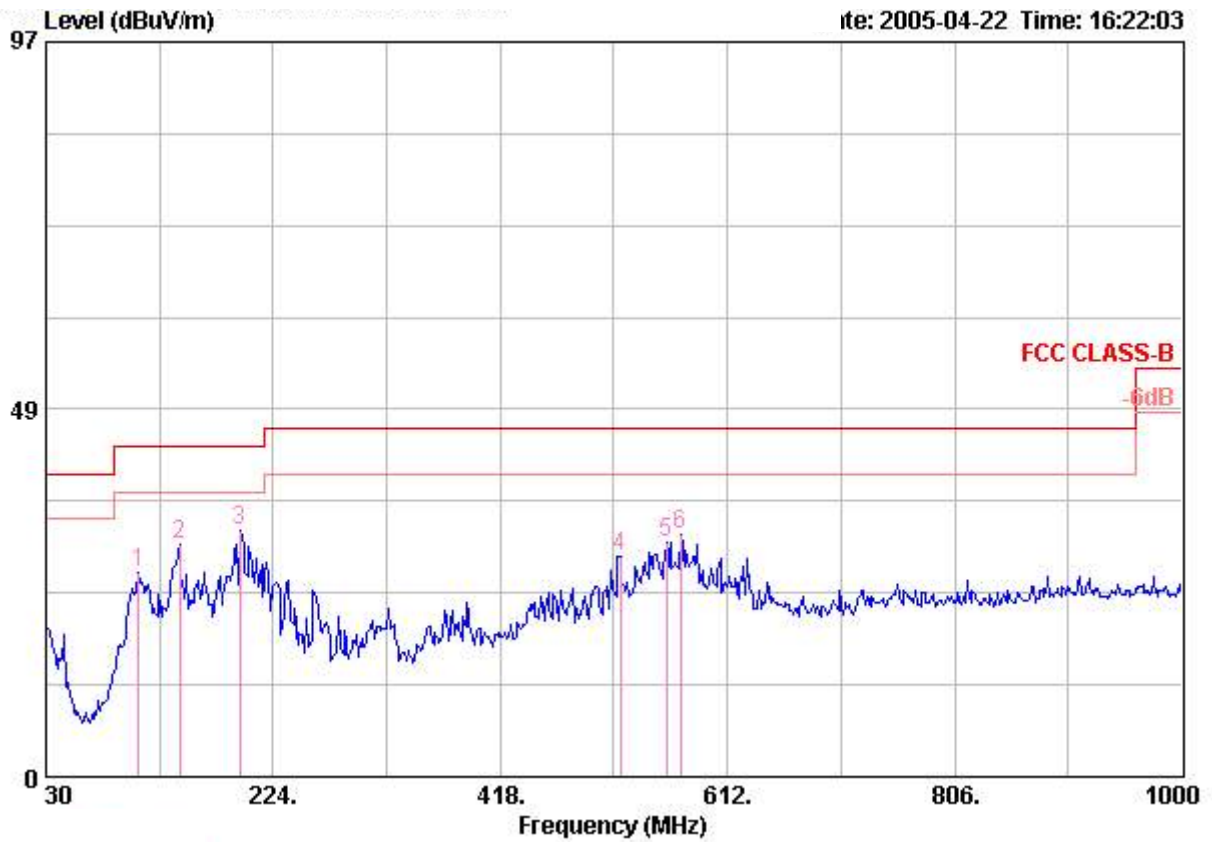

	Freq	Level	Over	Limit	Antenna	Cable	Preamp	Read	Pol/Phase	Remark
	MHz	dBUV/m	Limit	Line	Factor	Loss	Factor	Level		
			dB	dBUV/m	dB/m	dB	dB	dBUV		
1	109.540	26.86	-16.64	43.50	11.50	0.84	30.07	44.59	HORIZONTAL	Peak
2	144.460	30.55	-12.95	43.50	10.63	0.95	30.06	49.04	HORIZONTAL	Peak
3	195.870	32.41	-11.09	43.50	8.76	1.10	29.98	52.53	HORIZONTAL	Peak
4	520.820	29.11	-16.89	46.00	17.70	1.81	30.57	40.17	HORIZONTAL	Peak
5	559.620	30.99	-15.01	46.00	18.65	1.88	30.68	41.14	HORIZONTAL	Peak
6	572.230	32.08	-13.92	46.00	18.65	1.89	30.74	42.28	HORIZONTAL	Peak





**(B) Polarization: Vertical**

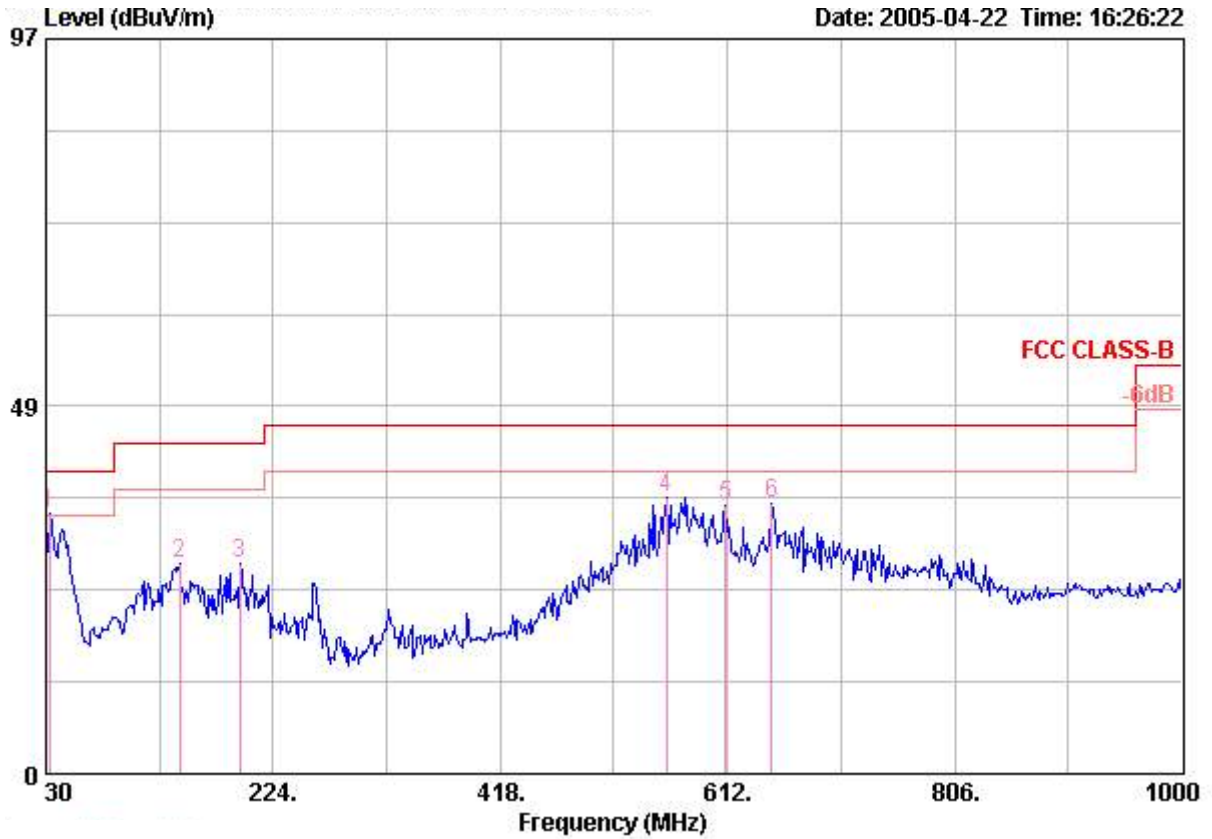

	Freq	Level	Over Limit	Limit	Antenna Line Factor	Cable Loss	Preamp Factor	Read Level	Pol/Phase	Remark
	MHz	dBuV/m	dB	dBuV/m	dB/m	dB	dB	dBuV		
<b>1 @</b>	<b>32.910</b>	<b>34.23</b>	<b>-5.77</b>	<b>40.00</b>	<b>16.45</b>	<b>0.49</b>	<b>29.78</b>	<b>47.07</b>	<b>VERTICAL</b>	<b>Peak</b>
<b>2</b>	<b>144.460</b>	<b>27.67</b>	<b>-15.83</b>	<b>43.50</b>	<b>10.63</b>	<b>0.95</b>	<b>30.06</b>	<b>46.16</b>	<b>VERTICAL</b>	<b>Peak</b>
<b>3</b>	<b>195.870</b>	<b>27.84</b>	<b>-15.66</b>	<b>43.50</b>	<b>8.76</b>	<b>1.10</b>	<b>29.98</b>	<b>47.96</b>	<b>VERTICAL</b>	<b>Peak</b>
<b>4</b>	<b>559.620</b>	<b>36.56</b>	<b>-9.44</b>	<b>46.00</b>	<b>18.65</b>	<b>1.88</b>	<b>30.68</b>	<b>46.71</b>	<b>VERTICAL</b>	<b>Peak</b>
<b>5</b>	<b>610.060</b>	<b>35.49</b>	<b>-10.51</b>	<b>46.00</b>	<b>18.76</b>	<b>1.94</b>	<b>30.77</b>	<b>45.56</b>	<b>VERTICAL</b>	<b>Peak</b>
<b>6</b>	<b>649.830</b>	<b>35.81</b>	<b>-10.19</b>	<b>46.00</b>	<b>18.89</b>	<b>2.02</b>	<b>30.32</b>	<b>45.22</b>	<b>VERTICAL</b>	<b>Peak</b>

Note:

Emission level (dBUV/m) = 20 log Emission level (uV/m)

Corrected Reading: Probe Factor + Cable Loss + Read Level - Preamp Factor = Level



5.6.8. Test Results for CH 01 / 2412 MHz (for emission above 1GHz)

- Modulation Type: DSSS
- Temperature: 16°C
- Relative Humidity: 60%
- Duty Cycle of the Equipment During the Test: 100.00%
- Test Engineer: Steven Lu

**(A) Polarization: Horizontal**

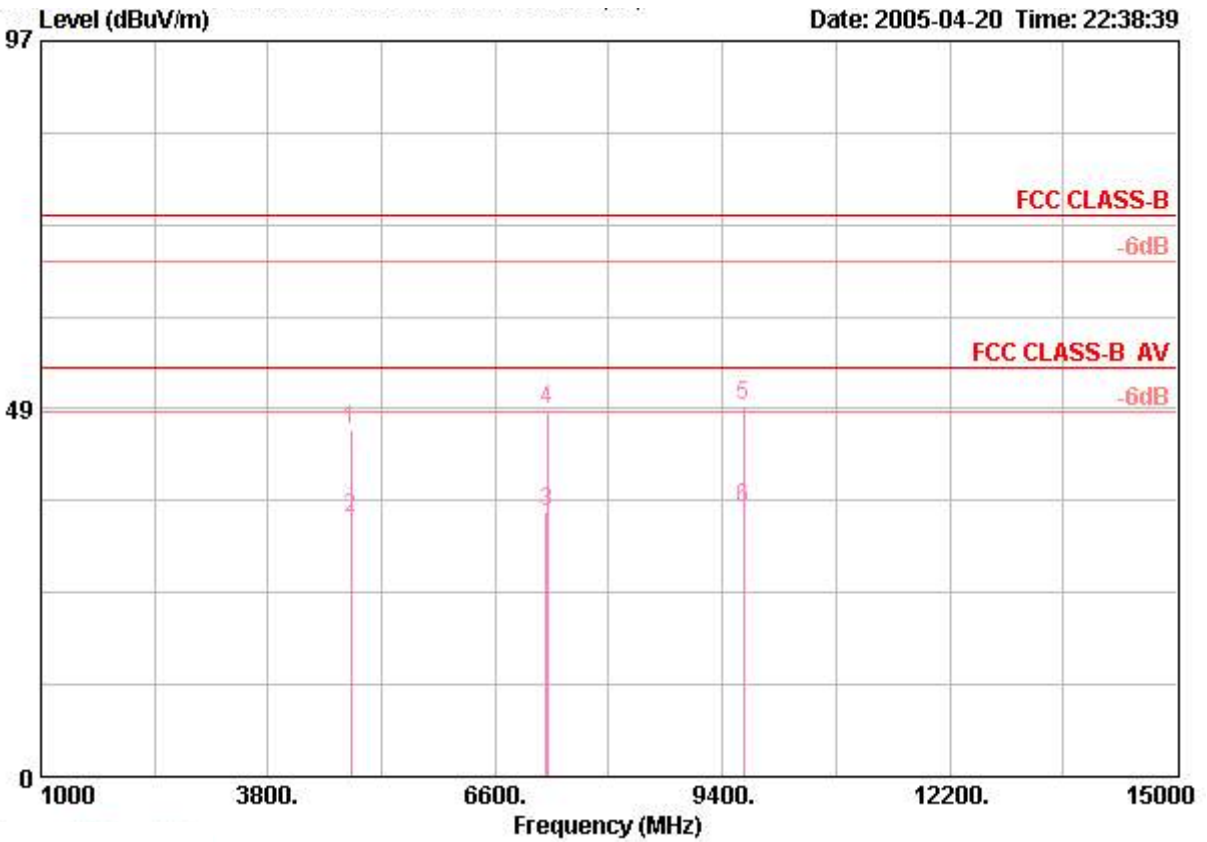

	Freq	Level	Over	Limit	Antenna	Cable	Preamp	Read	Pol/Phase	Remark
	MHz	dBuV/m	dB	dBuV/m	dB/m	dB	dB	dBuV		
1	4825.920	45.80	-28.20	74.00	33.22	3.20	37.61	46.98	HORIZONTAL	PEAK
2	4826.310	33.99	-20.01	54.00	33.22	3.20	37.61	35.17	HORIZONTAL	AVERAGE
3	7233.500	34.90	-19.10	54.00	36.08	4.41	39.15	33.57	HORIZONTAL	AVERAGE
4	7242.500	48.39	-25.61	74.00	36.08	4.41	39.19	47.09	HORIZONTAL	PEAK
5	9664.600	48.87	-25.13	74.00	38.44	5.16	36.07	41.34	HORIZONTAL	PEAK
6	9664.600	35.36	-18.64	54.00	38.44	5.16	36.07	27.83	HORIZONTAL	AVERAGE



(B) Polarization: Vertical

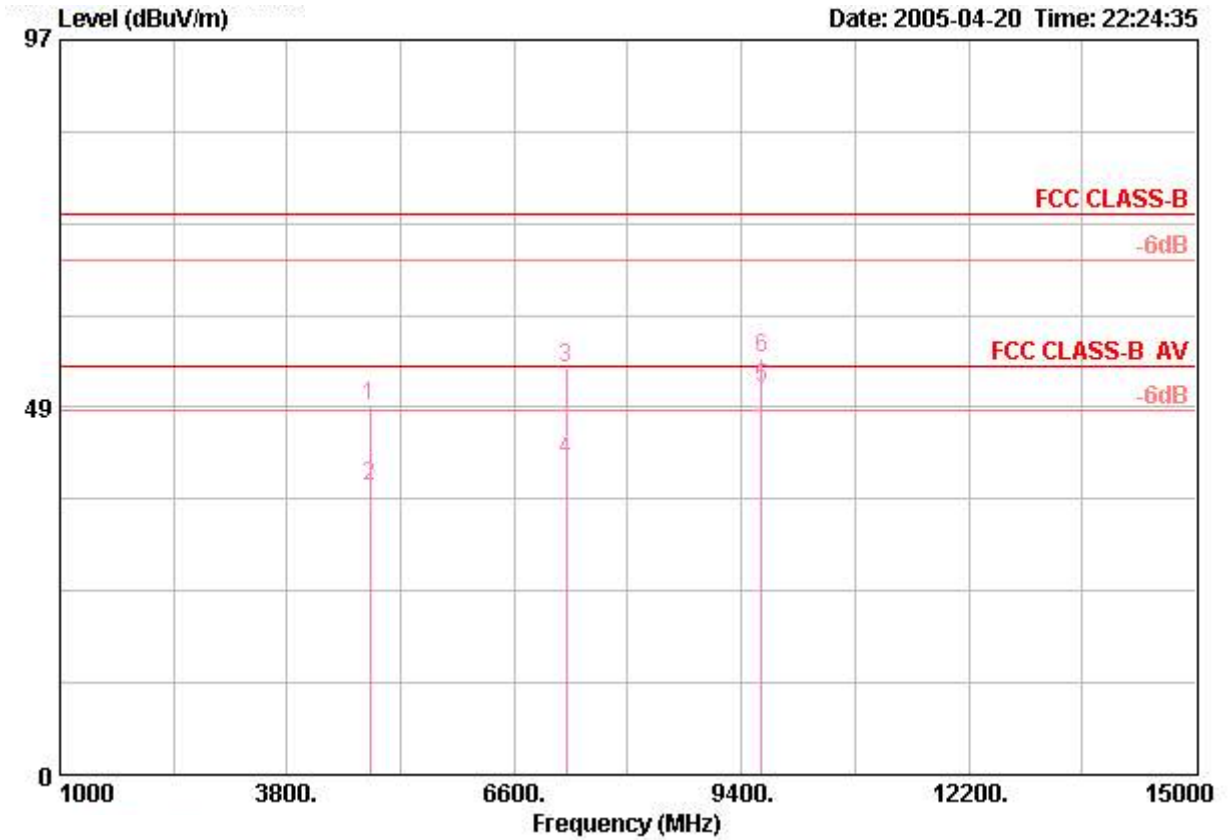

	Freq	Level	Over Limit	Limit	Antenna Line Factor	Cable Loss	Preamp Factor	Read Level	Pol/Phase	Remark
	MHz	dBuV/m	dB	dBuV/m	dB/m	dB	dB	dBuV		
1	4823.820	48.50	-25.50	74.00	33.22	3.20	37.61	49.68	VERTICAL	PEAK
2	4824.000	38.06	-15.94	54.00	33.22	3.20	37.61	39.24	VERTICAL	AVERAGE
3	7236.000	53.54	-20.46	74.00	36.08	4.41	39.19	52.24	VERTICAL	PEAK
4	7238.400	41.45	-12.55	54.00	36.08	4.41	39.19	40.15	VERTICAL	AVERAGE
5 @	9648.040	50.91	-3.09	54.00	38.42	5.16	36.04	43.37	VERTICAL	AVERAGE
6	9648.080	54.98	-19.02	74.00	38.42	5.16	36.04	47.44	VERTICAL	PEAK

Note:

Emission level (dBuV/m) = 20 log Emission level (uV/m)

Corrected Reading: Probe Factor + Cable Loss + Read Level - Preamp Factor = Level



5.6.9. Test Results for CH 06 / 2437 MHz (for emission above 1GHz)

- Modulation Type: DSSS
- Temperature: 16°C
- Relative Humidity: 60%
- Duty Cycle of the Equipment During the Test: 100.00%
- Test Engineer: Steven Lu

(A) Polarization: Horizontal

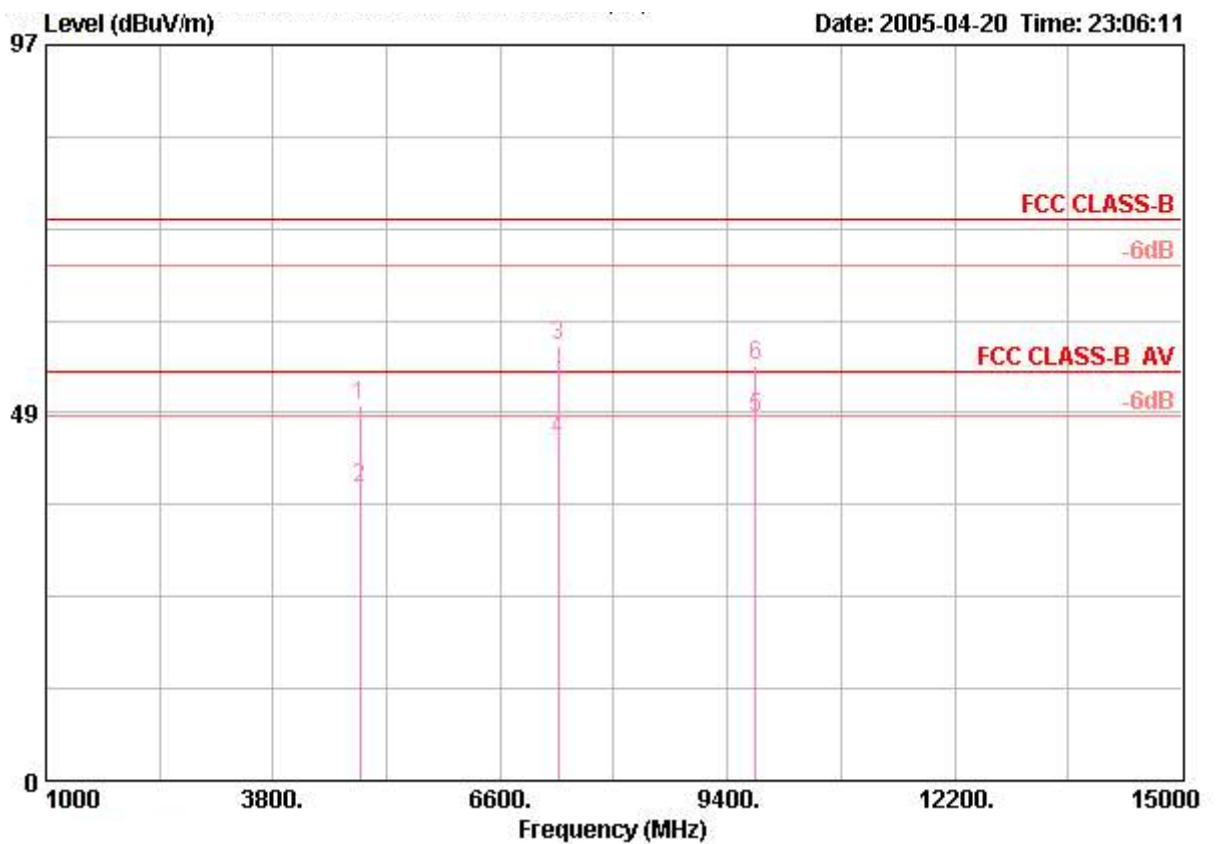

	Over	Limit	Antenna	Cable	Preamp	Read			
1	2	3	4	5	6	7	8	9	10
Freq	Level	Limit	Line	Factor	Loss	Factor	Level	Pol/Phase	Remark
MHz	dBuV/m	dB	dBuV/m	dB/m	dB	dB	dBuV		
1	4873.900	49.41	-24.59	74.00	33.33	3.22	37.65	50.50	HORIZONTAL PEAK
2	4874.064	38.60	-15.40	54.00	33.33	3.22	37.65	39.70	HORIZONTAL AVERAGE
3	7310.912	57.43	-16.57	74.00	36.24	4.44	39.25	55.99	HORIZONTAL PEAK
4	7310.968	44.96	-9.04	54.00	36.24	4.44	39.25	43.52	HORIZONTAL AVERAGE
5 @	9747.944	47.75	-6.25	54.00	38.56	5.07	36.16	40.28	HORIZONTAL AVERAGE
6	9748.020	54.68	-19.32	74.00	38.56	5.07	36.16	47.21	HORIZONTAL PEAK



(B) Polarization: Vertical

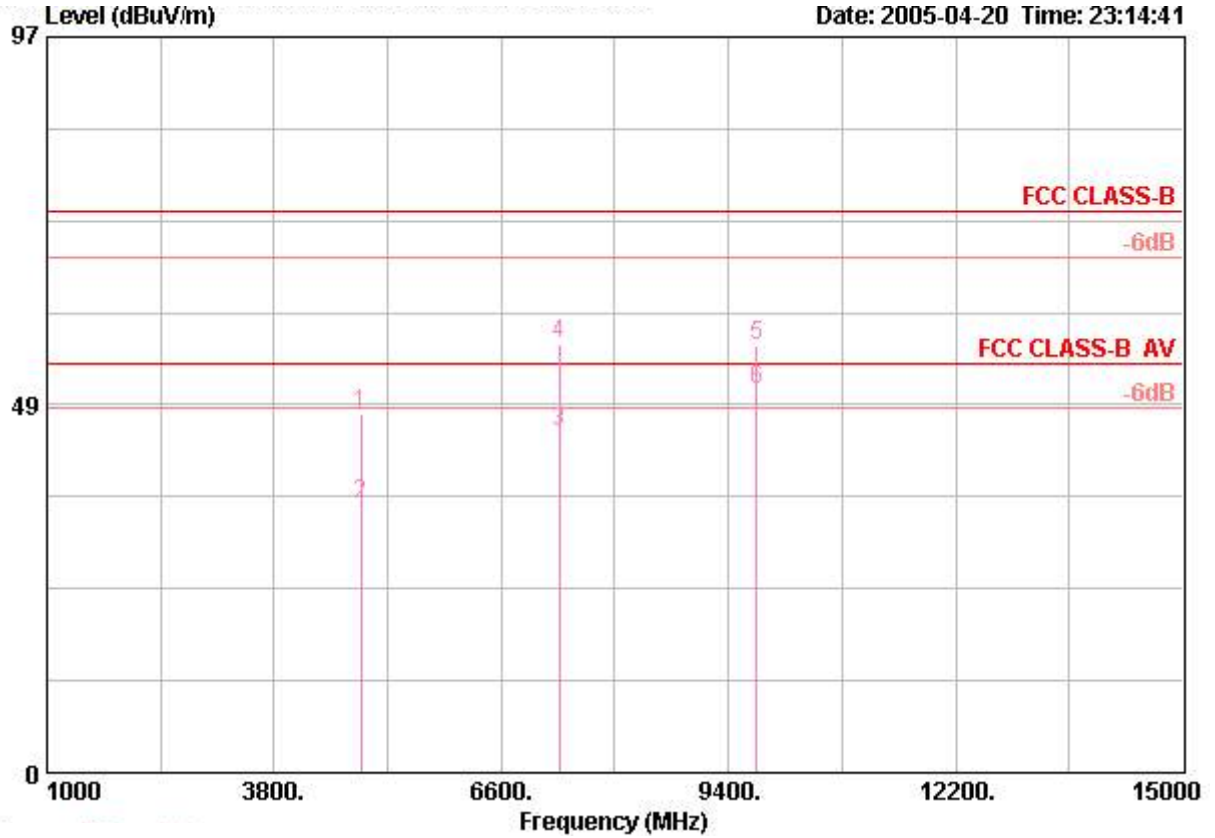

	Freq	Level	Over	Limit	Antenna	Cable	Preamp	Read		Remark
	MHz	dBuV/m	dB	dBuV/m	dB/m	dB	dB	dBuV	Pol/Phase	
1	4870.920	47.34	-26.66	74.00	33.33	3.22	37.65	48.43	VERTICAL	PEAK
2	4873.760	35.47	-18.53	54.00	33.33	3.22	37.65	36.57	VERTICAL	AVERAGE
3	7308.800	44.93	-9.07	54.00	36.24	4.44	39.25	43.49	VERTICAL	AVERAGE
4	7310.920	56.69	-17.31	74.00	36.24	4.44	39.25	55.25	VERTICAL	PEAK
5	9747.952	56.41	-17.59	74.00	38.56	5.07	36.16	48.94	VERTICAL	PEAK
6 @	9747.972	50.52	-3.48	54.00	38.56	5.07	36.16	43.05	VERTICAL	AVERAGE

Note:

Emission level (dBuV/m) = 20 log Emission level (uV/m)

Corrected Reading: Probe Factor + Cable Loss + Read Level - Preamp Factor = Level



5.6.10. Test Results for CH 11 / 2462 MHz (for emission above 1GHz)

- Modulation Type: DSSS
- Temperature: 16°C
- Relative Humidity: 60%
- Duty Cycle of the Equipment During the Test: 100.00%
- Test Engineer: Steven Lu

**(A) Polarization: Horizontal**

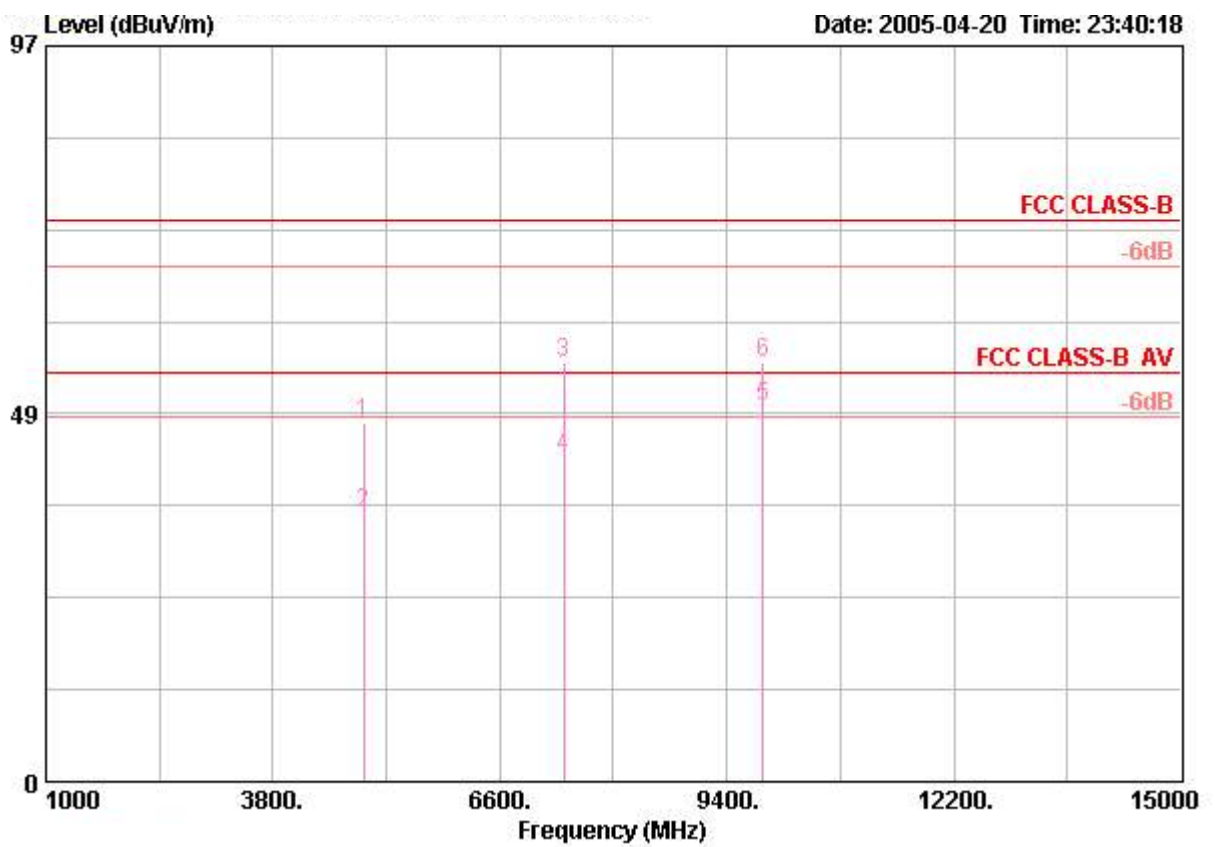

	Freq	Level	Over Limit	Limit	Antenna Line	Cable Loss	Preamp Factor	Read Level	Pol/Phase	Remark
	MHz	dBuV/m	dB	dBuV/m	dB/m	dB	dB	dBuV		
1	4923.680	47.37	-26.63	74.00	33.45	3.25	37.69	48.36	HORIZONTAL	PEAK
2	4924.030	35.48	-18.52	54.00	33.45	3.25	37.69	36.47	HORIZONTAL	AVERAGE
3	7385.990	55.23	-18.77	74.00	36.45	4.48	39.35	53.64	HORIZONTAL	PEAK
4	7388.430	42.77	-11.23	54.00	36.45	4.48	39.38	41.22	HORIZONTAL	AVERAGE
5 @	9847.980	49.41	-4.59	54.00	38.68	4.93	36.28	42.08	HORIZONTAL	AVERAGE
6	9848.070	55.22	-18.78	74.00	38.68	4.93	36.28	47.89	HORIZONTAL	PEAK



(B) Polarization: Vertical

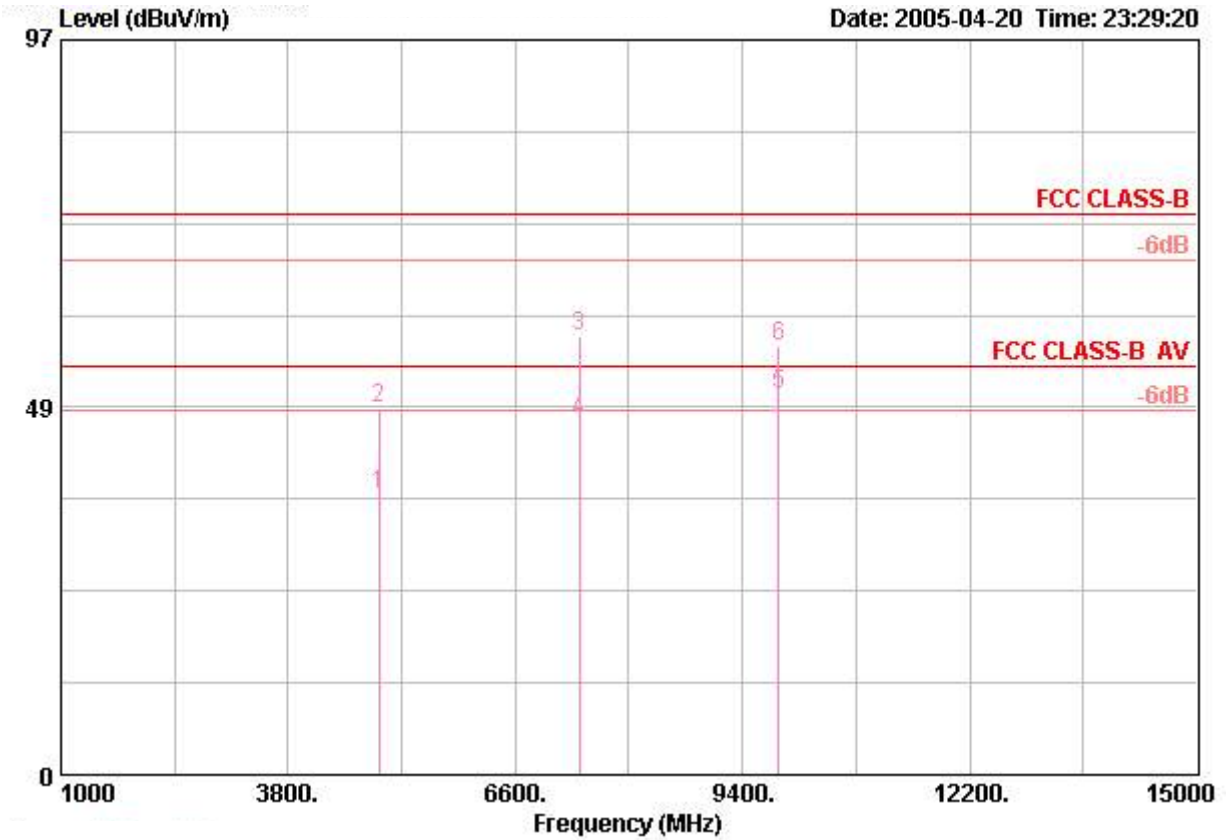

	Freq	Level	Over	Limit	Antenna	Cable	Preamp	Read	Pol/Phase	Remark
	MHz	dBuV/m	Limit	dB	Line	Loss	Factor	Level		
					Factor	Factor	dB	dB		
					dB/m	dB	dB	dB		
1	4923.860	36.87	-17.13	54.00	33.45	3.25	37.69	37.87	VERTICAL	AVERAGE
2	4924.060	48.39	-25.61	74.00	33.45	3.25	37.69	49.38	VERTICAL	PEAK
3	7386.160	57.89	-16.11	74.00	36.45	4.48	39.35	56.30	VERTICAL	PEAK
4	7386.190	46.79	-7.21	54.00	36.45	4.48	39.35	45.20	VERTICAL	AVERAGE
5 @	9847.980	50.24	-3.76	54.00	38.68	4.93	36.28	42.91	VERTICAL	AVERAGE
6	9848.200	56.57	-17.43	74.00	38.68	4.93	36.28	49.24	VERTICAL	PEAK

Note:

Emission level (dBUV/m) = 20 log Emission level (uV/m)

Corrected Reading: Probe Factor + Cable Loss + Read Level - Preamp Factor = Level

5.6.11. Photographs of Radiated Emission Test Configuration

Mode 1

FRONT VIEW



REAR VIEW





Mode 2

FRONT VIEW



REAR VIEW





---

## 5.7. Antenna Requirements

### 5.7.1. Standard Applicable

#### Section 15.203:

An intentional radiator shall be designed to ensure that no antenna other than that furnished by the responsible party shall be used with the device. The use of a permanently attached antenna or of an antenna that uses a unique coupling to the intentional radiator shall be considered sufficient to comply with the provisions of this Section. The manufacturer may design the unit so that a broken antenna can be replaced by the user, but the use of a standard antenna jack or electrical connector is prohibited.

#### Section 15.247(b)/(c):

If transmitting antennas of directional gain greater than 6 dBi are used, the peak output power from the intentional radiator shall be reduced by the amount in dB that the directional gain of the antenna exceeds 6 dBi.

If the intentional radiator is used exclusively for fixed, point-to-point operations may employ transmitting antennas with directional gain greater than 6 dBi provided the maximum peak output power of the intentional radiator is reduced by 1 dB for every 3 dB that the directional gain of the antenna exceeds 6 dBi.

### 5.7.2. Antenna Connected Construction

There is no antenna connector used for this chip antenna.

All antenna gain of EUT is less than 6dBi. Therefore peak conducted power limit shall not be degraded any more. Antenna report of manufacturer will have more detail antenna gain or antenna pattern.

### 5.7.3. Test Criteria

All test results complied with the requirements of 15.203/15.247(b)/(c).

## 5.8. RF Exposure

### 5.8.1. Limit For Maximum Permissible Exposure (MPE)

This product can be classified as mobile device, so the 20cm separation distance warning is required. In this section, the power density at 20cm location is calculated to examine if it is lower than the limit.

#### (A) Limits for Occupational / Controlled Exposure

Frequency Range (MHz)	Electric Field Strength (E) (V/m)	Magnetic Field Strength (H) (A/m)	Power Density (S) (mW/ cm <sup>2</sup> )	Averaging Time  E  <sup>2</sup> , H  <sup>2</sup> or S (minutes)
0.3-3.0	614	1.63	(100)*	6
3.0-30	1842 / f	4.89 / f	(900 / f)*	6
30-300	61.4	0.163	1.0	6
300-1500			F/300	6
1500-100,000			5	6

#### (B) Limits for General Population / Uncontrolled Exposure

Frequency Range (MHz)	Electric Field Strength (E) (V/m)	Magnetic Field Strength (H) (A/m)	Power Density (S) (mW/cm <sup>2</sup> )	Averaging Time  E  <sup>2</sup> , H  <sup>2</sup> or S ( minutes )
0.3-1.34	614	1.63	(100)*	30
1.34-30	824/f	2.19/f	(180/f)*	30
30-300	27.5	0.073	0.2	30
300-1500			F/1500	30
1500-100,000			1.0	30

F = frequency in MHz

\*Plane-wave equivalent power density

### 5.8.2. MPE Calculation Method

$$E \text{ (V/m)} = \frac{\sqrt{30 \times P \times G}}{d} \qquad \text{Power Density: } Pd \text{ (mW/cm}^2\text{)} = \frac{E^2}{377}$$

**E** = Electric field (V/m)

**P** = Peak RF output power (mW)

**G** = EUT Antenna numeric gain (numeric)

**d** = Separation distance between radiator and human body (m)

The formula can be changed to

$$Pd = \frac{30 \times P \times G}{377 \times d^2}$$

From the peak EUT RF output power, the minimum mobile separation distance, d=20cm, as well as the gain of the used antenna, the RF power density can be obtained.



5.8.3. Calculated Result and Limit

- Modulation Type: DSSS
- Temperature: 16°C
- Relative Humidity: 60%
- Duty Cycle of the Equipment During the Test: 100.00%
- Test Engineer: Steven Lu

Channel No.	Antenna Gain (dBi)	Antenna Gain (numeric)	Peak Output Power (dBm)	Peak Output Power ( mW )	Power Density (S) (mW/cm <sup>2</sup> )	Limit of Power Density (S) (mW/cm <sup>2</sup> )
01	2.50	1.78	16.00	39.81	0.0141	1
06	2.50	1.78	15.50	35.48	0.0126	1
11	2.50	1.78	15.00	31.62	0.0112	1



## 6. List of Measuring Equipments Used

Items	Instrument	Manufacturer	Model No.	Serial No.	Characteristics	Calibration Date	Remark
1	EMC Receiver	R&S	ESCS 30	100132	9kHz – 2.75GHz	Jun. 23, 2004	Conduction (CO01-HY)
2	LISN	MessTec	NNB-2/16Z	2001/009	9kHz – 30MHz	Apr. 26, 2005	Conduction (CO01-HY)
3	LISN (Support Unit)	MessTec	NNB-2/16Z	99081	9kHz – 30MHz	Dec. 17, 2004	Conduction (CO01-HY)
4	EMI Filter	LINDGREN	LRE-2060	1004	< 450Hz	N/A	Conduction (CO01-HY)
5	EMI Filter	LINDGREN	N6006	201052	0 – 60Hz	N/A	Conduction (CO01-HY)
6	RF Cable-CON	Suhner Switzerland	RG223/U	CB029	9kHz – 30MHz	Dec. 23, 2004	Conduction (CO01-HY)
7	3m Semi Anechoic Chamber	SIDT FRANKONIA	SAC-3M	03CH03-HY	30MHz~1GHz 3m	Jun. 21, 2004	Radiation (03CH03-HY)
8	Spectrum analyzer	R&S	FSP40	100004	9KHZ~40GHz	Aug. 31, 2004	Radiation (03CH03-HY)
9	Amplifier	SCHAFFNER	CPA9231A	18667	9KHz – 2GHz	Jan. 10, 2005	Radiation (03CH03-HY)
10	Biconical Antenna	SCHWARZBECK	VHBB 9124	301	30MHz – 200MHz	Jul. 28, 2004	Radiation (03CH03-HY)
11	Log Antenna	SCHWARZBECK	VUSLP 9111	221	200MHz -1GHz	Jul. 28, 2004	Radiation (03CH03-HY)
12	RF Cable-R03m	Jye Bao	RG142	CB021	30MHz~1GHz	Feb. 22, 2005	Radiation (03CH03-HY)
13	Amplifier	MITEQ	AFS44	849984	100MHz~26.5GHz	Mar. 25, 2005	Radiation (03CH03-HY)
14	Horn Antenna	EMCO	3115	6741	1GHz – 18GHz	Apr. 06, 2005	Radiation (03CH03-HY)
15	Turn Table	HD	DS 420	420/650/00	0 ~ 360 degree	N/A	Radiation (03CH03-HY)
16	Antenna Mast	HD	MA 240	240/560/00	1 m - 4 m	N/A	Radiation (03CH03-HY)
17	Horn Antenna	Schwarzbeck	BBHA9170	154	18GHz~40GHz	Jun. 09, 2004	Radiation (03CH03-HY)
18	RF Cable-HIGH	Jye Bao	RG142	CB030-HIGH	1GHz~29.5GHz	Dec.01, 2004	Radiation (03CH03-HY)

※ Calibration Interval of instruments listed above is one year.



Items	Instrument	Manufacturer	Model No.	Serial No.	Characteristics	Calibration Date	Remark
19	Spectrum analyzer	R&S	FSP30	100023	9KHZ~30GHZ	Aug. 02, 2004	Conducted (TH01-HY)
20	Power meter	R&S	NRVS	100444	DC~40GHz	Jun. 15, 2004	Conducted (TH01-HY)
21	Power sensor	R&S	NRV-Z55	100049	DC~40GHz	Jun. 15, 2004	Conducted (TH01-HY)
22	Power Sensor	R&S	NRV-Z32	100057	30MHz-6GHz	Jun. 15, 2004	Conducted (TH01-HY)
23	AC power source	HPC	HPA-500W	HPA-9100024	AC 0~300V	Jun. 16, 2004	Conducted (TH01-HY)
24	DC power source	G.W.	GPC-6030D	C671845	DC 1V~60V	Nov. 05, 2004	Conducted (TH01-HY)
25	Temp. and Humidity Chamber	KSON	THS-C3L	612	N/A	Oct. 01, 2004	Conducted (TH01-HY)
26	RF CABLE-1m	Jye Bao	RG142	CB034-1m	20MHz~7GHz	Jan. 01, 2005	Conducted (TH01-HY)
27	RF CABLE-2m	Jye Bao	RG142	CB035-2m	20MHz~1GHz	Jan. 01, 2005	Conducted (TH01-HY)

※ Calibration Interval of instruments listed above is one year.

## 7. Company Profile

SPORTON Lab. was established in 1986 with one shielded room: the first private EMI test facility, offering local manufacturers an alternative EMI test facility apart from ERSO. In 1988, one 3M and 10M/3M open area test site were setup and also obtained official accreditation from FCC, VCCI and NEMKO. In 1993, a Safety laboratory was founded and obtained accreditation from UL of USA, CSA of Canada and TUV (Rhineland & PS) of Germany. In 1995, one EMC lab, including EMI and EMS test facilities was setup. In 1997, SPORTON Group has provided financial expense to relocate the headquarter to Orient Scientific Park in Taipei Hsien to offer more comprehensive, more qualified and better service to local suppliers and manufactures. In 1999, Safety Group and Component Group were setup. In 2001, SPORTON has established 3M/10M chamber in Hwa Ya Technology Park.

### 7.1. Certificate of Accreditation

Taiwan	BSMI, CNLA, DGT
USA	FCC, NVLAP, UL
EU	Nemko, TUV
Japan	VCCI
Canada	Industry Canada

### 7.2. Test Location

SHIJR	ADD : 6Fl., No. 106, Sec. 1, Shintai 5th Rd., Shijr City, Taipei, Taiwan 221, R.O.C. TEL : 02-2696-2468 FAX : 02-2696-2255
HWA YA	ADD : No. 52, Hwa Ya 1st Rd., Hwa Ya Technology Park, Kwei-Shan Hsiang, Tao Yuan Hsien, Taiwan, R.O.C. TEL : 03-327-3456 FAX : 03-318-0055
LINKOU	ADD : No. 30-2, Dingfu Tsuen, Linkou Shiang, Taipei, Taiwan 244, R.O.C TEL : 02-2601-1640 FAX : 02-2601-1695
DUNGHU	ADD : No. 3, Lane 238, Kangle St., Neihu Chiu, Taipei, Taiwan 114, R.O.C. TEL : 02-2631-4739 FAX : 02-2631-9740
JUNGHE	ADD : 7Fl., No. 758, Jungjeng Rd., Junghe City, Taipei, Taiwan 235, R.O.C. TEL : 02-8227-2020 FAX : 02-8227-2626
NEIHU	ADD : 4Fl., No. 339, Hsin Hu 2 <sup>nd</sup> Rd., Taipei 114, Taiwan, R.O.C. TEL : 02-2794-8886 FAX : 02-2794-9777

## 8. CNLA Certificate of Accreditation

Test Lab. : Sporton International Inc.  
Accreditation Number : 1190  
Originally Accredited : 2003/12/15  
Effective Period : 2003/12/15~2006/12/14  
Accredited Scope : 47 CFR FCC Part 15 Subpart C (9kHz~40GHz)



Taiwan Accreditation Foundation  
Chinese National Laboratory Accreditation  
Certificate of Accreditation

Accreditation Criteria: ISO 17025  
Accreditation Number: 1190  
Organization/Laboratory: EMC & Wireless Communications Laboratory, Sporton International Inc.  
Originally Accredited: December 15, 2003  
Effective Period: December 15, 2003 To December 14, 2006  
Accredited Scope: Electrical Testing Field, 7 items, details shown in the following pages.  
Specific Accreditation Program: Recognition and Approval of Designated Laboratory for Commodities Inspection

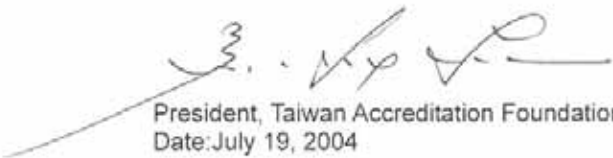
  
President, Taiwan Accreditation Foundation  
Date: July 19, 2004

(This document is invalid unless accompanied by all 4 pages)

CNLA-ZL03191E Page 1 of 4