



**Telecommunications & Telematics
for Transports Lab.**

TEST REPORT

Ref. No. ARSH00132

Date: 2007-07-26

Measurements performed in accordance with:



**FCC Rules : Code of Federal Regulations (CFR) no. 47 -
PART 15 – RADIO FREQUENCY DEVICES**

PRODUCT : ZigBee module general purpose

TESTED MODEL : SPZB250

FCC ID : S9NZB250A

APPLICANT : STMicroelectronics – Centro Direzionale Colleoni – Palazzo
Andromeda 3 – I-20044 Agrate Brianza (MI) - ITALY

MANUFACTURER : STMicroelectronics – Centro Direzionale Colleoni – Palazzo
Andromeda 3 – I-20044 Agrate Brianza (MI) - ITALY

TRADEMARK : STMicroelectronics

OTHER INFORMATION

Testing dates : 2007-07-19 ÷ 2007-07-20

Tested samples No. : 2

Testing Laboratory : IMQ S.p.A. Via Quintiliano, 43 I-20138 MILANO

Tested by : R. Radice Signature: *Roberto Radice* Date : 2007-07-26

R. Colombo
Checked by: (EMC and R&TTE Lab. Deputy) Signature: *Roberto Colombo* Date : 2007-07-26

Revision Sheet

Release No.	Date	Revision Description
Rev. 0	2007-07-26	Test Results and Evaluation Report

*NOTICE: The results of tests and checks reported in this Test Report refer exclusively to the samples tested and described in the Report itself.
This report shall not be reproduced partially or in its entirety without the written approval of IMQ S.p.A.*

IMQ S.p.A. - Via Quintiliano, 43 – I-20138 MILANO

CONTENTS

1	General Description of Equipment under Test	1-3
1.1	APPLICANT	1-3
1.2	MANUFACTURER.....	1-3
1.3	EQUIPMENT CLASSIFICATION	1-3
1.4	BASIC DESCRIPTION OF EQUIPMENT UNDER TEST.....	1-4
1.5	FEATURE OF EQUIPMENT UNDER TEST	1-5
2	Test Configuration of Equipment under Test	2-7
2.1	ENVIRONMENTAL CONDITIONS	2-7
2.2	DESCRIPTION OF SUPPORT EQUIPMENT.....	2-7
2.3	INTERFACE IDENTIFICATION AND CONNECTION DIAGRAM OF TEST SYSTEM.....	2-8
3	Operation of Equipment under Test	3-9
3.1	OPERATING TEST CONDITIONS	3-9
4	Tests Identification and Results	4-10
4.1	METHODS OF MEASUREMENT	4-12
4.2	FREQUENCY RANGE INVESTIGATED	4-12
5	Measurements and Tests Data.....	5-13
6	Additional Technical Information	6-42
6.1	ELECTROMAGNETICALLY RELEVANT COMPONENTS:.....	6-42
6.2	RFI SUPPRESSION DEVICES:	6-42
6.3	EMI PROTECTION DEVICES:	6-42
7	Technical Documentation.....	7-43
8	Photographic Documentation	8-44
8.1	EUT IDENTIFICATION	8-44
8.2	TEST SET-UP	8-47
9	Measurement and Test Equipment Instrumentation	9-49

1 GENERAL DESCRIPTION OF EQUIPMENT UNDER TEST

1.1 APPLICANT

NAME	STMicroelectronics
ADDRESS	Centro Direzionale Colleoni – Palazzo Andromeda 3 – I-20044 Agrate Brianza (MI)
COUNTRY	ITALY

1.2 MANUFACTURER

NAME	STMicroelectronics
ADDRESS	Centro Direzionale Colleoni – Palazzo Andromeda 3 – I-20044 Agrate Brianza (MI)
COUNTRY	ITALY

1.3 EQUIPMENT CLASSIFICATION

According to the definition 15.3 (o) EUT is a **Intentional Radiator operating within the bands 2400-2483,5 MHz** so it shall fulfil provisions of 47CFR Part 15 Subpart C – Intentional radiators – and Section 15.247.

1.4 BASIC DESCRIPTION OF EQUIPMENT UNDER TEST

Parameters	Value
Type of equipment :	<ul style="list-style-type: none">▪ ZigBee module general purpose
Model :	<ul style="list-style-type: none">▪ SPZB250
FCC ID. :	<ul style="list-style-type: none">▪ S9NZB250A
Trade Name	<ul style="list-style-type: none">▪ STMicroelectronics
Data cable :	<ul style="list-style-type: none">▪ /
Telecom cable :	<ul style="list-style-type: none">▪ /
Power supply type :	<ul style="list-style-type: none">▪ DC 3.3V, 41,5mA max.
AC power input cable :	<ul style="list-style-type: none">▪ /
DC power input cable :	<ul style="list-style-type: none">▪ /

1.5 FEATURE OF EQUIPMENT UNDER TEST

Power specification	▪ 3.3 V dc
Operating frequency:	▪ 2405 ÷ 2480 MHz (16 Channels)
Maximum RF output power:	▪ < 1 W
Modulation:	▪ O-QPSK
Channel Spacing:	▪ >1 MHz
Antenna:	▪ Dedicated antenna (0,6 dBi gain) integrated in the test jig
RX sensitivity:	▪ -92 dBm
Main SW identification	▪ /
Main HW Board identification	▪ /
Peripherals included (for system application)	▪ None
Interfaces :	▪ None
Integrated interfaces :	▪ None
AC adapter:	▪ None

CHANNEL CONFIGURATION

Channel (No.)	Frequency (MHz)
11	2405.00
12	2410.00
13	2415.00
14	2420.00
15	2425.00
16	2430.00
17	2435.00
18	2440.00
19	2445.00
20	2450.00
21	2455.00
22	2460.00
23	2465.00
24	2470.00
25	2475.00
26	2480.00

2 TEST CONFIGURATION OF EQUIPMENT UNDER TEST

2.1 ENVIRONMENTAL CONDITIONS

TEST CONDITIONS	MEASURED
Ambient Temperature	20 ÷ 25 °C
Relative Humidity	50 ÷ 60 %
Atmospheric Pressure	900 ÷ 1000 mbar

2.2 DESCRIPTION OF SUPPORT EQUIPMENT

Here following the details concerning equipment needed for correct operation or loading of the EUT:

EQUIPMENT	MANUFACTURER	MODEL
Personal Computer	IBM	-----
Test Jig	STMicroelectronics	-----
AC/DC Adapter	STMicroelectronics	GSPPJ-5215STM/1

2.3 INTERFACE IDENTIFICATION AND CONNECTION DIAGRAM OF TEST SYSTEM

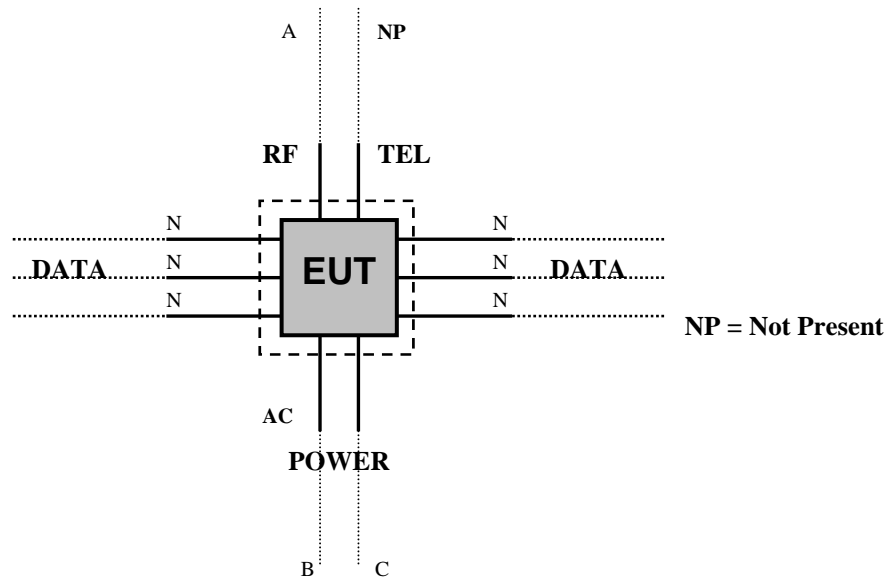

#	Interface	Description	Maximum length	Ref. Document
1	Enclosure	Open frame board	/	/
2	AC mains power input/output port	Port not present	/	/
3	DC power port	3,3V dc furnished on test jig board; ZigBee module: 3.3 V dc	/	/
4	Signal / control port	Port not present	/	/
5	Antenna port (RF)	Dedicated SMD antenna integrated on ZigBee module	/	SPZB250 & SPZB260 antenna gain

3 OPERATION OF EQUIPMENT UNDER TEST

3.1 OPERATING TEST CONDITIONS

Ref.	Description
#1	Continuous transmission with Boost mode activated (single channel transmission)

4 TESTS IDENTIFICATION AND RESULTS

TABLE 1 : SUMMARY OF TESTS

CFR47 Part 15 Section	Title	Operating condition	Result	Test No.
15.203 15.247 (b)(4)(i)	Antenna Requirements	/	PASS	1
15.207 (a)	Conducted Emission	#1	PASS	2
15.209 (a) (f)	Radiated Emission	#1	PASS	3
15.247 (a)	Frequency Hopping Spread Spectrum Specifications			
15.247(a)(1)(iii)	Number of Hopping Channels Used	Not applicable		
15.247(a)	20 dB Bandwidth	Not applicable		
15.247(a)(1)	Carrier frequency (Hopping Channel) Separation	Not applicable		
15.247(a)(1)(iii)	Time occupancy (Dwell Time) of Each Channel (ch) within a $0,4 \times N_{ch}$ (sec) Period	Not applicable		
15.247(a)(2)	6dB Minimum Bandwidth	#1	PASS	4
15.247(b)	Maximum Peak Output Power			
15.247(b) (1)	Peak Output Power	#1	PASS	5
15.247(b) (4)	Antenna gain	Not applicable		
15.247(c)	Operation with directional antenna gains greater than 6 dBi	Not applicable		
15.247 (d)	100 kHz Bandwidth of Frequency Band Edges	#1	PASS	6

15.247 (d)	Conducted Emission	#1	PASS	7
15.247 (e)	Power Spectral Density	#1	PASS	8
15.247 (f)	Hybrid systems	Not applicable		
15.247 (g)	FHSS Transmission characteristics	Not applicable		
15.247 (h)	Recognition of occupied channel and multiple transmission system	Not applicable		
15.247(i) (§ 47CFR 1.1307(b)(1))	RF humane exposure	#1	PASS	9

4.1 METHODS OF MEASUREMENT

All compliance measurements have been carried out using the procedures described in the standard ANSI C63.4-2003 (excluding sub-par. 4.1.5.2, 5.7.9 and 14) and Section 15.31 of CFR47 Part 15 – Subpart A (General).

Additional test requirements have been adopted according to the reference Section indicated in the Test Table

4.2 FREQUENCY RANGE INVESTIGATED

- a. Conducted emission tests : from 150 kHz to 30 MHz.
- b. Radiated emission tests : from 30 MHz to tenth harmonic of fundamental

5 MEASUREMENTS AND TESTS DATA

TEST No. 1	Title "Antenna Requirements"	47CFR Part 15 Ref. Section 15.203 / 15.204
TEST REQUIREMENTS	An intentional radiator shall be designed to ensure that no antenna other than that furnished by the responsible party shall be used with the device. The use of a permanently attached antenna or of an antenna that uses a unique coupling to the intentional radiator shall be considered sufficient to comply with the provisions of this Section. The manufacturer may design the unit so that a broken antenna can be replaced by the user, but the use of a standard antenna jack or electrical connector is prohibited. This requirement does not apply to carrier current devices or to devices operated under the provisions of Sections 15.211, 15.213, 15.217, 15.219, or 15.221. Further, this requirement does not apply to intentional radiators that must be professionally installed, such as perimeter protection systems and some field disturbance sensors, or to other intentional radiators which, in accordance with Section 15.31(d), must be measured at the installation site. However, the installer shall be responsible for ensuring that the proper antenna is employed so that the limits in this Part are not exceeded.	

Antenna specifications		
N° of authorized antenna types	▪ 2	
Antenna type	▪ Dedicated SMD antenna integrated on ZigBee MODULE	
Maximum total gain	▪ 0,6 dBi	
External power amplifiers	▪ Not present	
Antenna Description		
No.	Manufacturer	Model Type
1	ANTENOVA	Rufa A5839
2	MURATA	ANCV12G44SAA127

Test Result:

The transmitter meets the requirements of section 15.203 and 15.204

TEST No. 2	Title "Conducted emission"	47CFR Part 15 Ref. Section
		15.207
TEST REQUIREMENTS	Test setup	ANSI C63.4
	Limits of mains terminal disturbance voltage	15.207 (a)
	Frequency range	150 kHz – 30 MHz
	IF bandwidth	9 kHz
	EMC class	B

TEST DATA	PORT UNDER TEST	OPERATING CONDITION	RESULT
		AC mains power input port	#1
Note: In search of max noise (phase(s) and neutral). The measurements with Quasi-Peak detector are performed only for frequencies for which the Peak values are \geq (Q.P. limit - 6 dB).			

Test Result:

Within the specifications

MEASUREMENTS RESULTS

CONDUCTED DISTURBANCE ON AC MAINS POWER PORT OF AC/DC ADAPTER

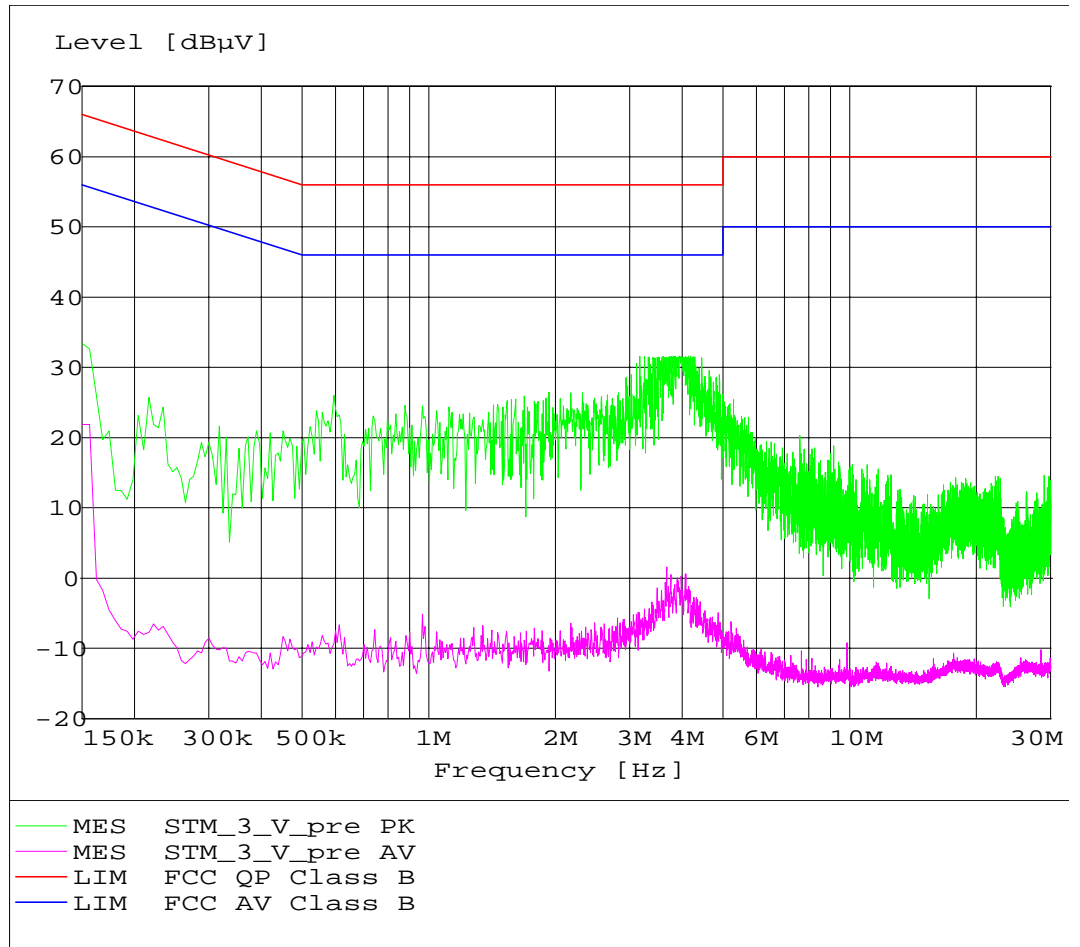

TEST No. 3	Title "Radiated disturbances"	47CFR Part 15 Ref. Section
		15.209
TEST REQUIREMENTS	Test setup	ANSI C63.4
	Test facility	Anechoic chamber
	Test distance	3 m
	Limits for radiated disturbances	15.209 (a)
	Frequency range	30 MHz to tenth harmonic of fundamental
	IF bandwidth (below 1000 MHz)	100 kHz
	IF bandwidth (above 1000 MHz)	1 MHz
	EMC class	B

	PORT UNDER TEST	OPERATING CONDITION	RESULT
TEST DATA	Enclosure	#1	Complies
	Note: In search of max noise (EUT rotation: from 0° to 360°; receiving antenna height: from 1 to 4m; receiving antenna polarization: horizontal and vertical). The measurements with Quasi-Peak detector, below 1000 MHz are performed only for frequencies for which the Peak values are \geq (Q.P. limit - 6 dB).		

Modification during the test:

- None

Tested samples

SAMPLE	
1)	EUT provided with ANTENOVA Antenna
2)	EUT provided with MURATA Antenna

MEASUREMENTS RESULTS (below 1000 MHz) – Vertical pol.

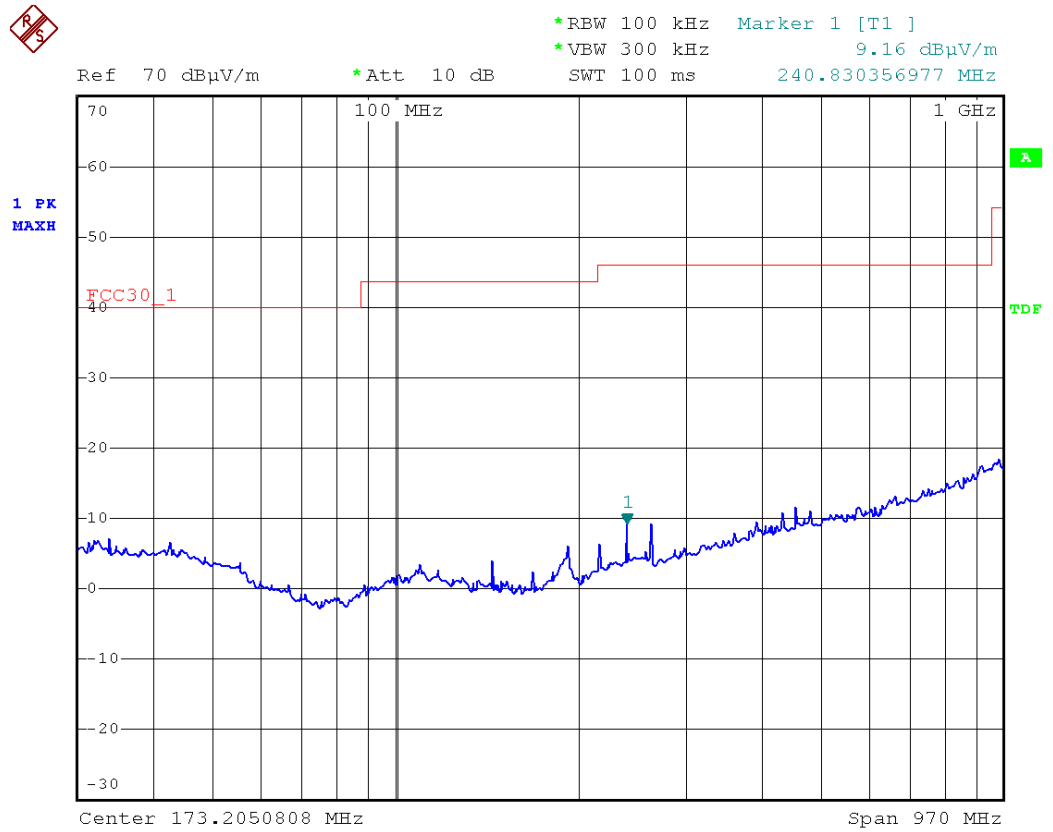

MEASUREMENTS RESULTS (below 1000 MHz) – Horizontal pol.

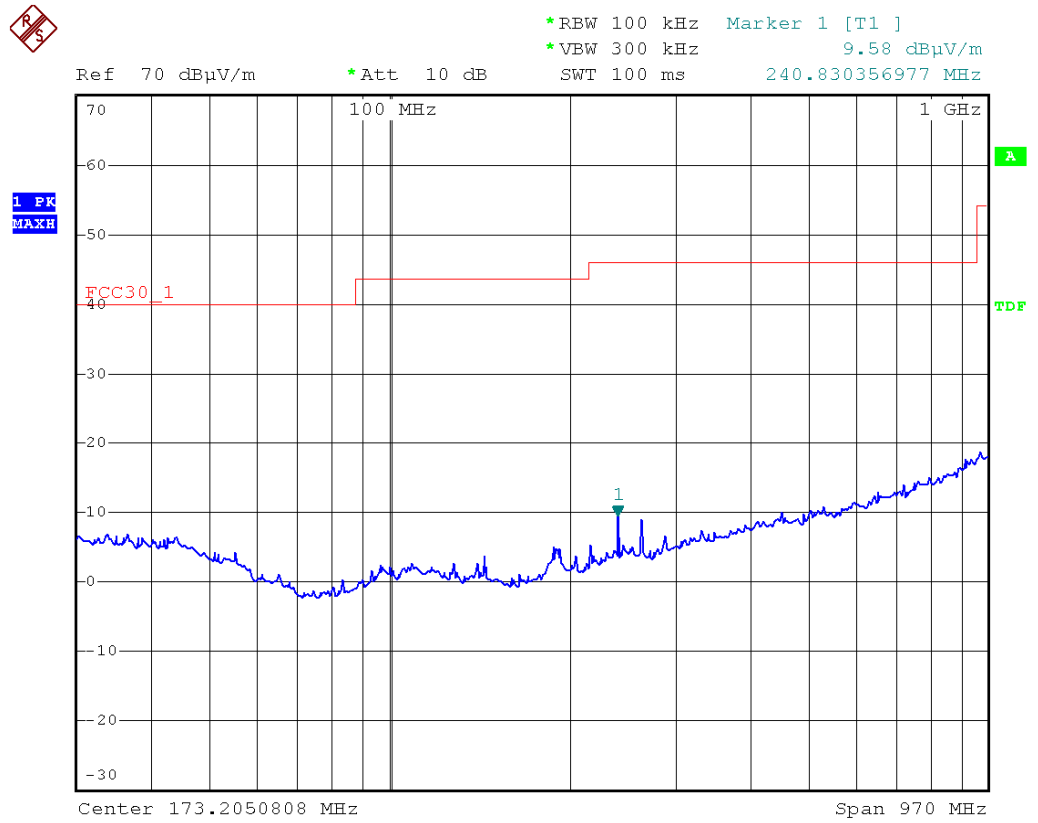

MEASUREMENTS RESULTS (1000 MHz to 24800 MHz)

Channel n°11: 2405,00 MHz

PEAK RESULT (RBW=1MHz; VBW=1MHz)

Frequency (MHz)	Measured Level (dB μ V/m)	Limit (μ Volt/meter)	Limit (dB μ V/m)	Margin (dB)	Pol.
2405,42 (fundamental)	95,34	-----	-----	-----	Vertical
4810,88	47,44	5000	74,00	26,56	Vertical
7216,46	54,59	5000	74,00	19,41	Vertical
9621,68	< 40,00	5000	74,00	> 34,00	Vertical
12024,1	< 40,00	5000	74,00	> 34,00	Vertical
f>12030	No spurious				

AVERAGE FACTOR

T. Pulse (ms)	TX on + TX off (ms)	Duty cycle	Average Factor (dB)
4,415	19,475	0,226	-12,89

AVERAGE RESULT (RBW=1MHz; VBW=10Hz)

Frequency (MHz)	Measured Level (dB μ V/m)	Limit (μ Volt/meter)	Limit (dB μ V/m)	Margin (dB)	Pol.
2405,42 (fundamental)	66,29	-----	-----	-----	Vertical
4810,88	44,42	500	54,00	9,58	Vertical
7216,46	51,51	500	54,00	2,49	Vertical
9621,68	< 40,00	500	54,00	> 14,00	Vertical
12024,1	< 40,00	500	54,00	> 14,00	Vertical
f>12030	No spurious				

Channel n°20: 2450,00 MHz

PEAK RESULT (RBW=1MHz; VBW=1MHz)

Frequency (MHz)	Measured Level (dB μ V/m)	Limit (μ Volt/meter)	Limit (dB μ V/m)	Margin (dB)	Pol.
2450,48 (fundamental)	94,71	-----	-----	-----	Vertical
4898,88	51,31	5000	74,00	22,69	Vertical
7351,52	60,61	5000	74,00	13,39	Vertical
9800	< 40,00	5000	74,00	> 34,00	Vertical
12250	< 40,00	5000	74,00	> 34,00	Vertical
f>12260	No spurious				

AVERAGE FACTOR

T. Pulse (ms)	TX on + TX off (ms)	Duty cycle	Average Factor (dB)
4,415	19,475	0,226	-12,89

AVERAGE RESULT (RBW=1MHz; VBW=10Hz)

Frequency (MHz)	Measured Level (dB μ V/m)	Limit (μ Volt/meter)	Limit (dB μ V/m)	Margin (dB)	Pol.
2450,48 (fundamental)	65,91	-----	-----	-----	Vertical
4898,88	45,51	500	54,00	8,49	Vertical
7351,52	53,32	500	54,00	0,68	Vertical
9800	< 40,00	500	54,00	> 14,00	Vertical
12250	< 40,00	500	54,00	> 14,00	Vertical
f>12260	No spurious				

Channel n°26: 2480,00 MHz

PEAK RESULT (RBW=1MHz; VBW=1MHz)

Frequency (MHz)	Measure Level (dB μ V/m)	Limit (μ Volt/meter)	Limit (dB μ V/m)	Margin (dB)	Pol.
2479,48 (fundamental)	93,08	-----	-----	-----	Vertical
4960,88	51,81	5000	74,00	22,19	Vertical
7438,48	57,41	5000	74,00	16,59	Vertical
9920	< 40,00	5000	74,00	> 34,00	Vertical
12400	< 40,00	5000	74,00	> 34,00	Vertical
f>12400	No spurious				

AVERAGE FACTOR

T. Pulse (ms)	TX on + TX off (ms)	Duty cycle	Average Factor (dB)
4,415	19,475	0,226	-12,89

AVERAGE RESULT (RBW=1MHz; VBW=10Hz)

Frequency (MHz)	Measured Level (dB μ V/m)	Limit (μ Volt/meter)	Limit (dB μ V/m)	Margin (dB)	Pol.
2479,48 (fundamental)	65,22	-----	-----	-----	Vertical
4960,88	45,82	500	54,00	8,18	Vertical
7438,48	52,79	500	54,00	1,21	Vertical
9920	< 40,00	500	54,00	> 14,00	Vertical
12400	< 40,00	500	54,00	> 14,00	Vertical
f>12400	No spurious				

DUTY CYCLE

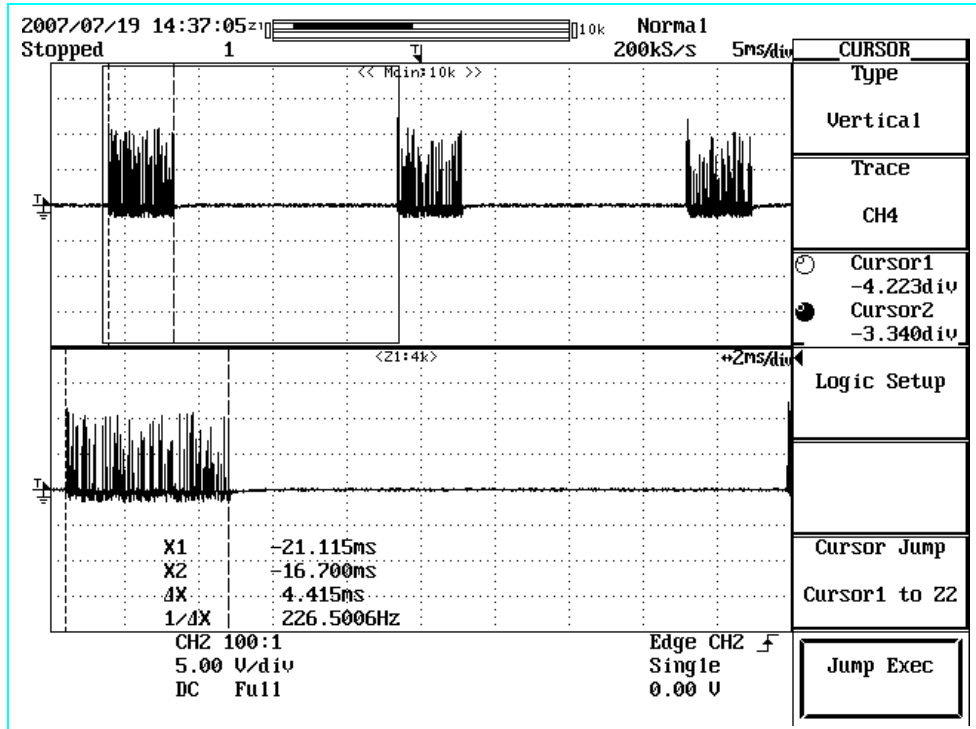

TX ON: 4,415ms

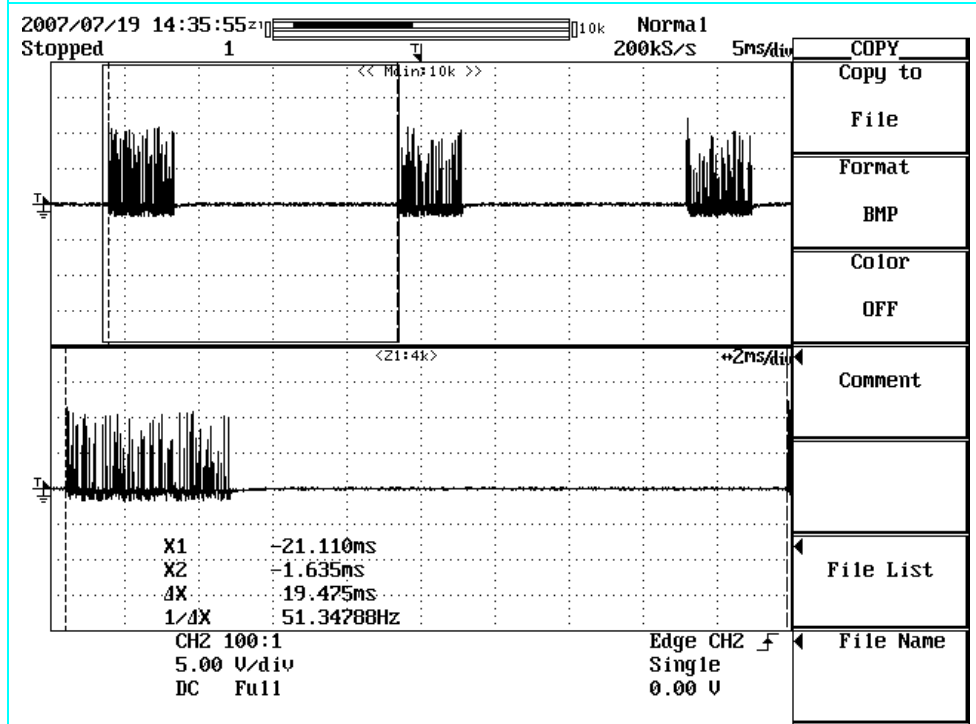

TX ON+TXOFF: 19,475ms

TEST No.4	Title	47CFR Part 15 Ref. Section
		"6 dB Bandwidth"
TEST SET-UP & REQUIREMENTS	Spectrum analyzer settings	
	Span	4 MHz
	Resolution (or IF) Bandwidth (RBW)	100 kHz
	Video (or Average) Bandwidth (VBW)	300 kHz
	Sweep time	2,5 ms
	Detector function	Peak
	Trace	max hold
	Attenuator	/
	LIMIT	-----

The EUT is set to transmit has its maximum data rate.
 The transmitter output was connected to the spectrum analyzer.
 The Channel bandwidth is defined as the total spectrum the power of which is higher than peak power minus 6 dB.

Test Result:

Channel (No.)	Frequency (MHz)	Hopping Channel Bandwidth (kHz)	Plot (No.)
11	2405,00	1520	1
20	2450,00	1400	2
26	2480,00	1224	3

Modification during the test:

- none

Plot No. 1÷3:

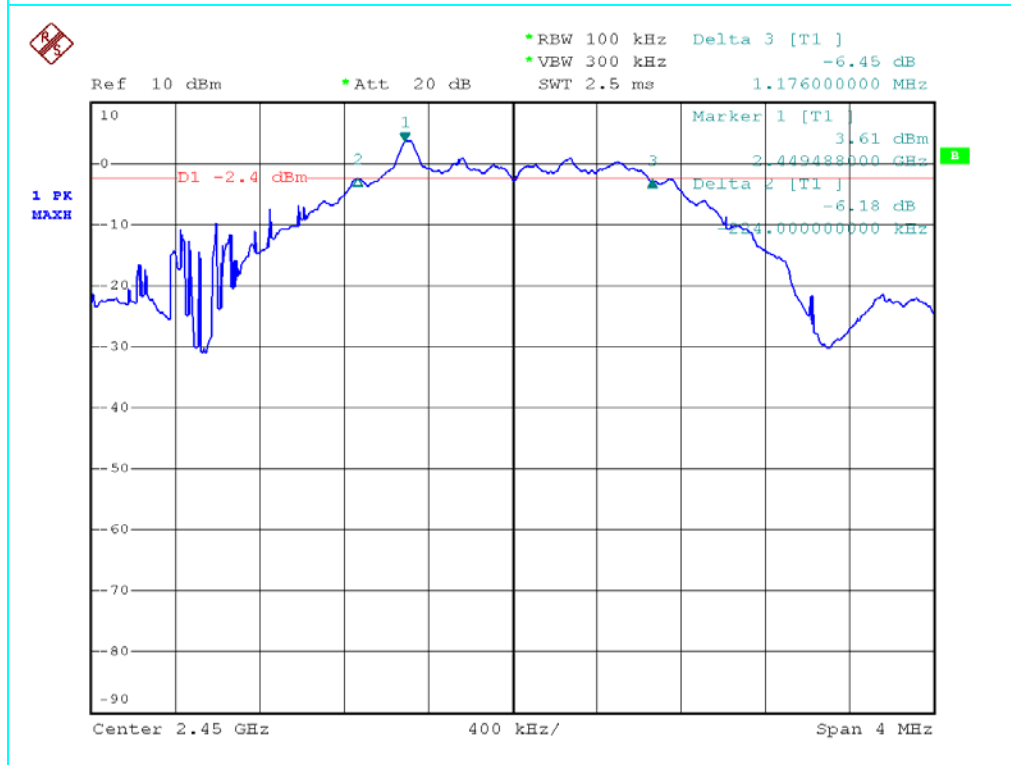
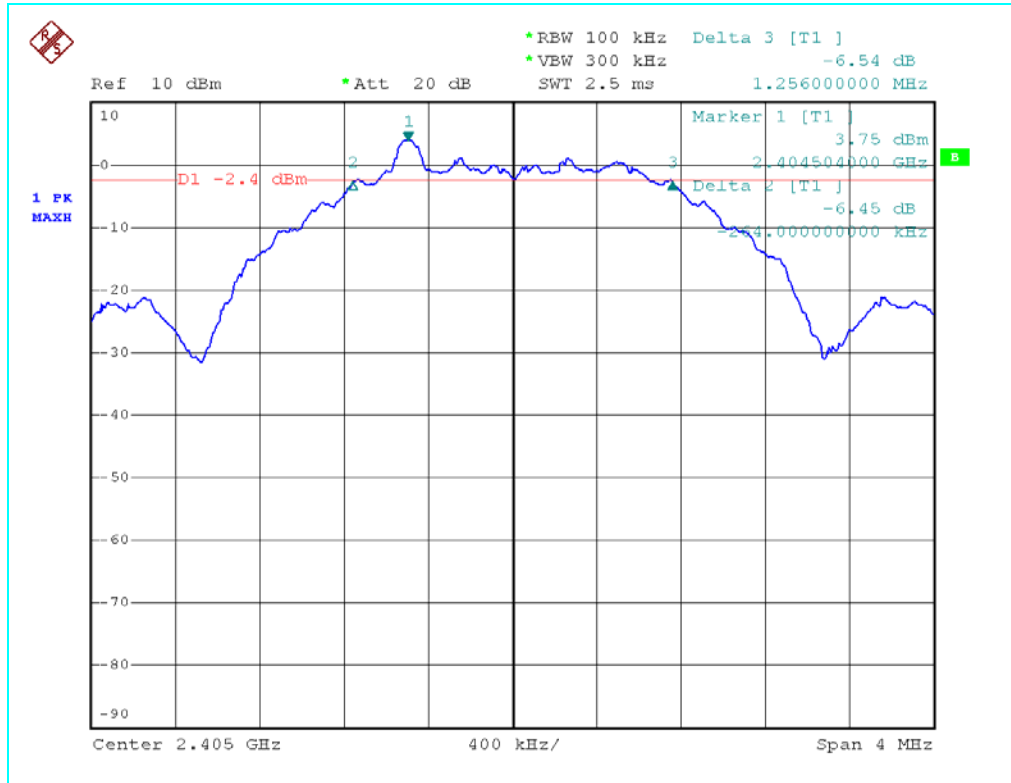

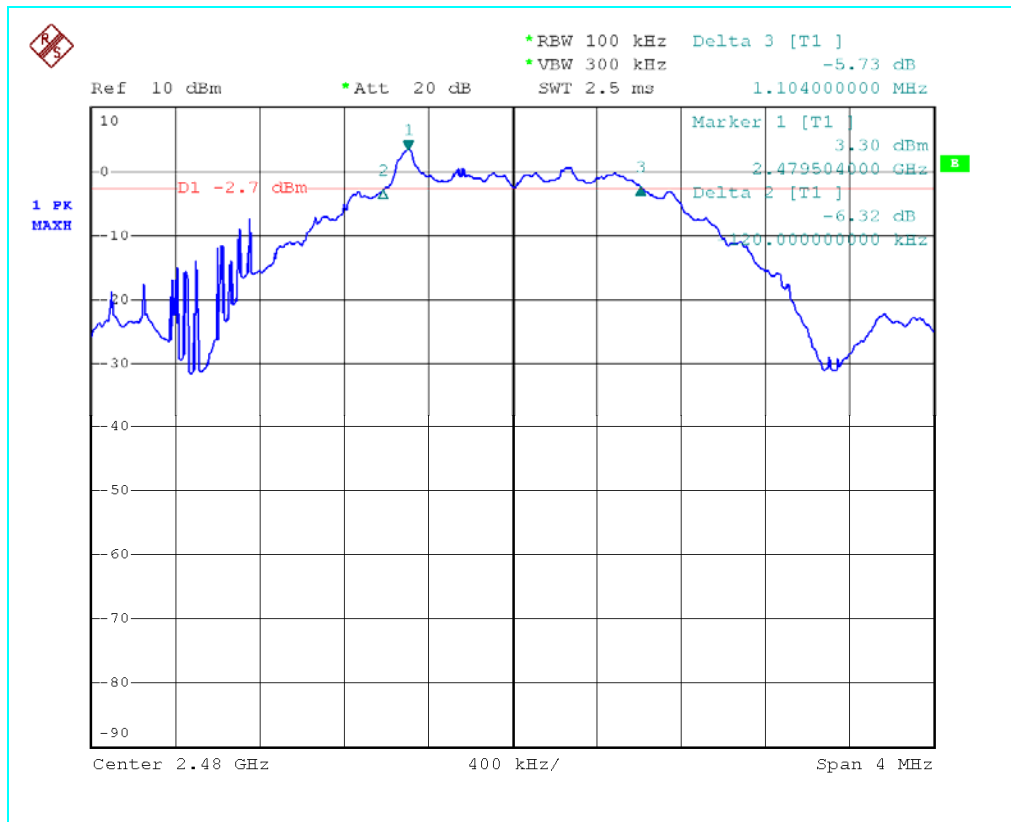

TEST No.5	Title	47CFR Part 15 Ref. Section
		“ Maximum Peak Output Power with External Antenna (De Facto EIRP)”
TEST SET-UP & REQUIREMENTS	Spectrum analyzer settings	
	Span	20 MHz
	Resolution (or IF) Bandwidth (RBW)	3 MHz
	Video (or Average) Bandwidth (VBW)	3 MHz
	Sweep time	2,5 ms
	Detector function	Peak
	Trace	max hold
	Attenuator	/
	LIMIT	1 Watt (30dBm)

Conducted measurements:

The transmitter output was connected to the spectrum analyzer via a low loss cable.

Radiated measurements:

As the EUT is supplied with a dedicated antenna, the effective radiated power is measured in a 3 m anechoic chamber with the substitution antenna method.

Tested samples

SAMPLE
1) EUT provided with ANTENOVA Antenna
2) EUT provided with MURATA Antenna

Test Result

Conducted measure (Peak detector)

Channel (No.)	Frequency (MHz)	Measured Output Power (dBm)	Cable loss (dB)	Conducted Output Power (dBm)	Antenna Gain (dB)	Calculated Radiated Output Power (dBm)
11	2405,00	4,22	+0,67	4,89	0,6	5,49
20	2450,00	3,82		4,49		5,06
26	2480,00	3,55		4,22		4,86

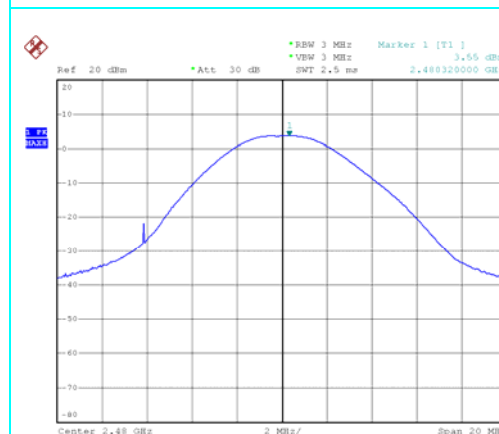
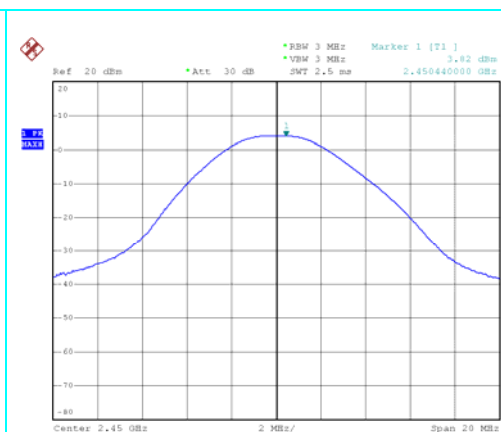
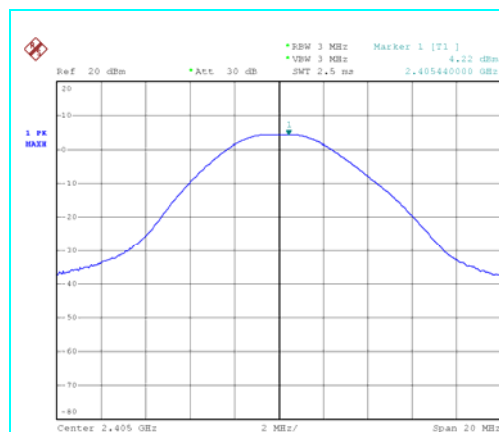

BLANK

Test Result: Radiated measure

Channel (No.)	Frequency (MHz)	Measured Output Power (dBm)	Measured Output Power (mW)
11	2405,00	4,15	2,600
20	2450,00	3,85	2,427
26	2480,00	3,15	2,065

Modification during the test:

- none

TEST No. 6	Title “Band-edge Compliance of RF Conducted Emissions “		47CFR Part 15 Ref. Section
			15.247 (d)
TEST SET-UP & REQUIREMENTS	Spectrum analyzer settings		
	Span	Wide enough to capture the peak level of the emission operating on the channel closest to the band edge, as well as any modulation products which fall outside of the authorized band of operation	
	Resolution (or IF) Bandwidth (RBW)	100 kHz	
	Video (or Average) Bandwidth (VBW)	100 kHz	
	Sweep time	Auto	
	Detector function	Peak	
	Trace	Max hold	
	Attenuator	/	
	LIMIT	> 20 dB below that in the 100 kHz bandwidth within the assigned band	

The transmitter output was connected to the spectrum analyzer through a test fixture (radio frequency coupling device associated with the dedicated antenna of the equipment under test)

Once the trace is stabilized, by the marker the emission at the band edge (or on the highest modulation product outside of the band, if this level is greater than that at the band edge) was set.

The n by the marker-delta function and the marker-to-peak function the peak of the in-band emission was selected. The marker-delta value displayed was compared with the limit specified in this Section.

Test Result:

Band-edge compliance, lower band edge

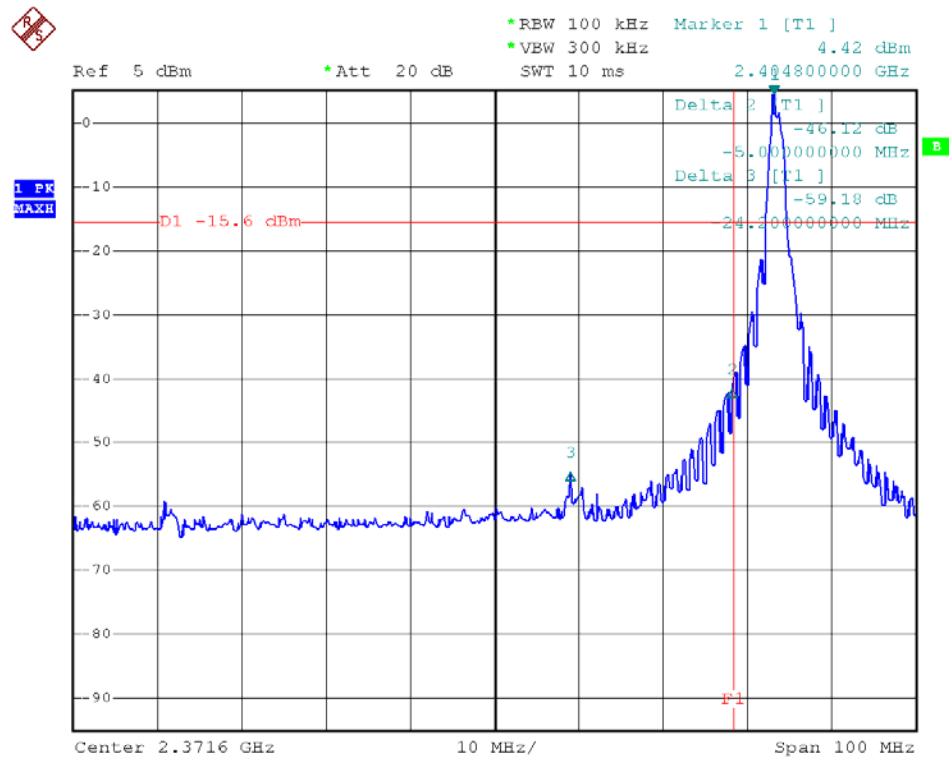

All out of band spurious emissions are more than 20 dB below of the fundamental in band field strength level.

Band-edge compliance to radiated emission test				
Band edge	Different to the signal peak (dB) (Marker 2)	Field strength measured (dB μ V/m)	Field strength at the band-edge (peak detector)	Average Limit at the band-edge
Lower	46,12	95,34	49,22	54,00
Within the limit				

Band-edge compliance, upper band edge

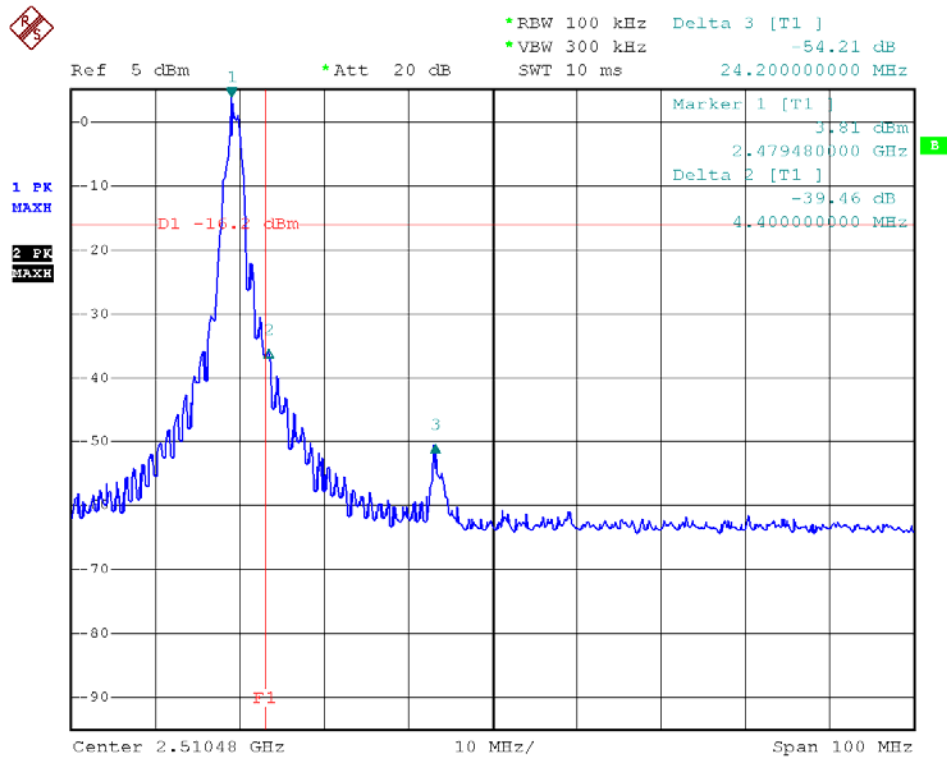

All out of band spurious emissions are more than 20 dB below of the fundamental in band field strength level.

Band-edge compliance to radiated emission test				
Band edge	Different to the signal peak (dB) (Marker 2)	Field strength measured (dB μ V/m)	Field strength at the band-edge (peak detector)	Average Limit at the band-edge
Upper	39,46	93,07	53,61	54,00
Within the limit				

TEST No.7	Title “ Conducted emission”		47CFR Part 15 Ref. Section
			15.247 (d)
TEST SET-UP & REQUIREMENTS	Spectrum analyzer settings		
	Span	1 MHz	
	Resolution (or IF) Bandwidth (RBW)	100 kHz	
	Video (or Average) Bandwidth (VBW)	100 kHz	
	Sweep time	as necessary to capture the entire dwell time per hopping channel	
	Detector function	Peak	
	Trace	max hold	
	Attenuator	/	
	LIMIT	20 dB below from Conducted peak of RF or limit specified in section 15.209 for Restricted Band.	

The EUT has to be connected to the spectrum analyser via a low loss cable. If the EUT is not equipped with an antenna connector, a temporary antenna connector has to be installed. The EUT has to be switched on and the hopping function has to be disenabled.

Test Result: Conducted measure (channel 11)

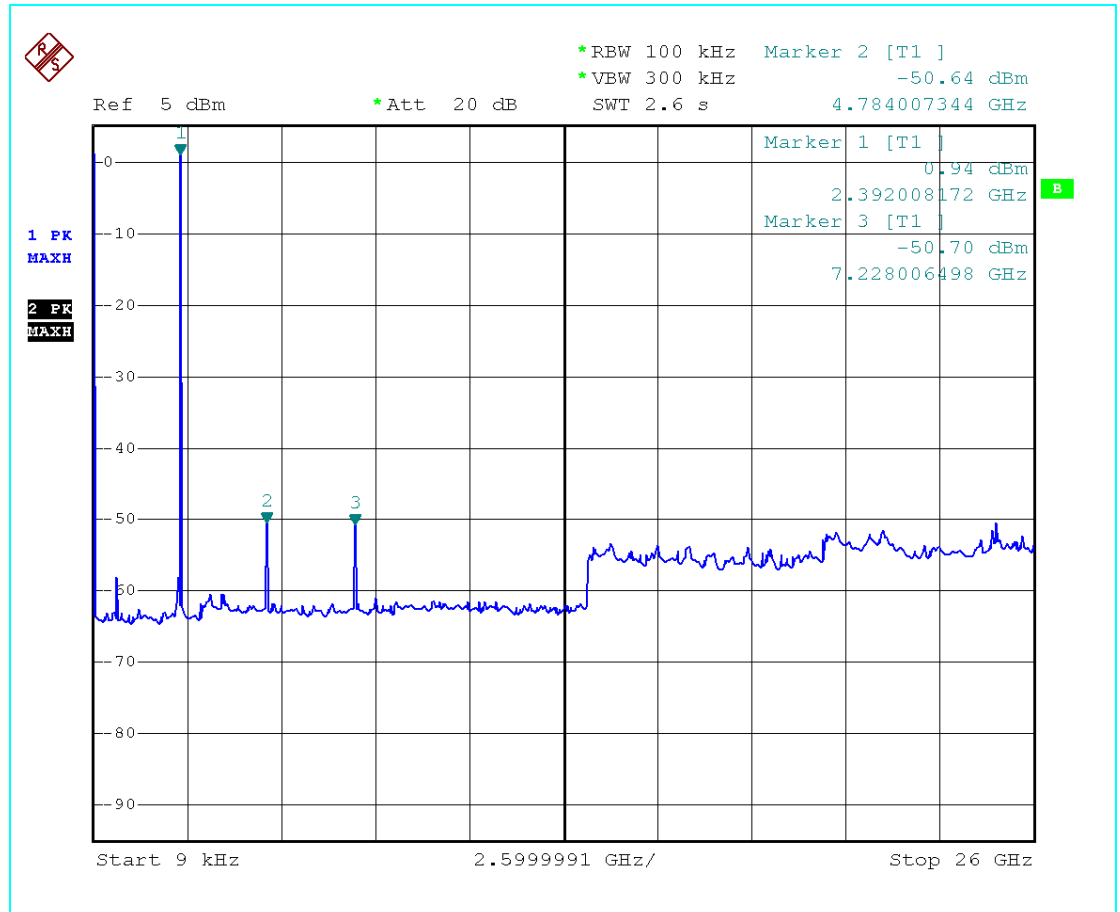

All out of band spurious emissions are more than 20 dB below of the fundamental in band field strength level.

Conducted measure (channel 20)

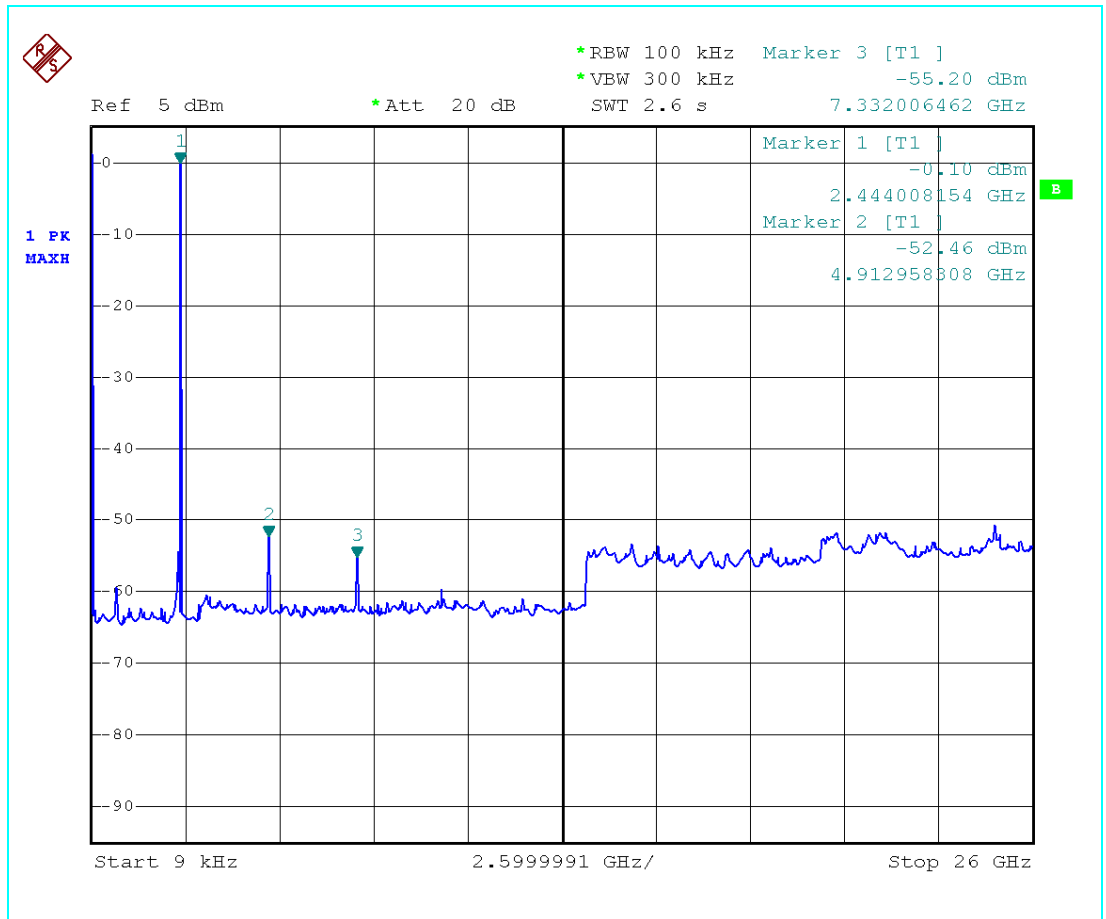

Conducted measure (channel 26)

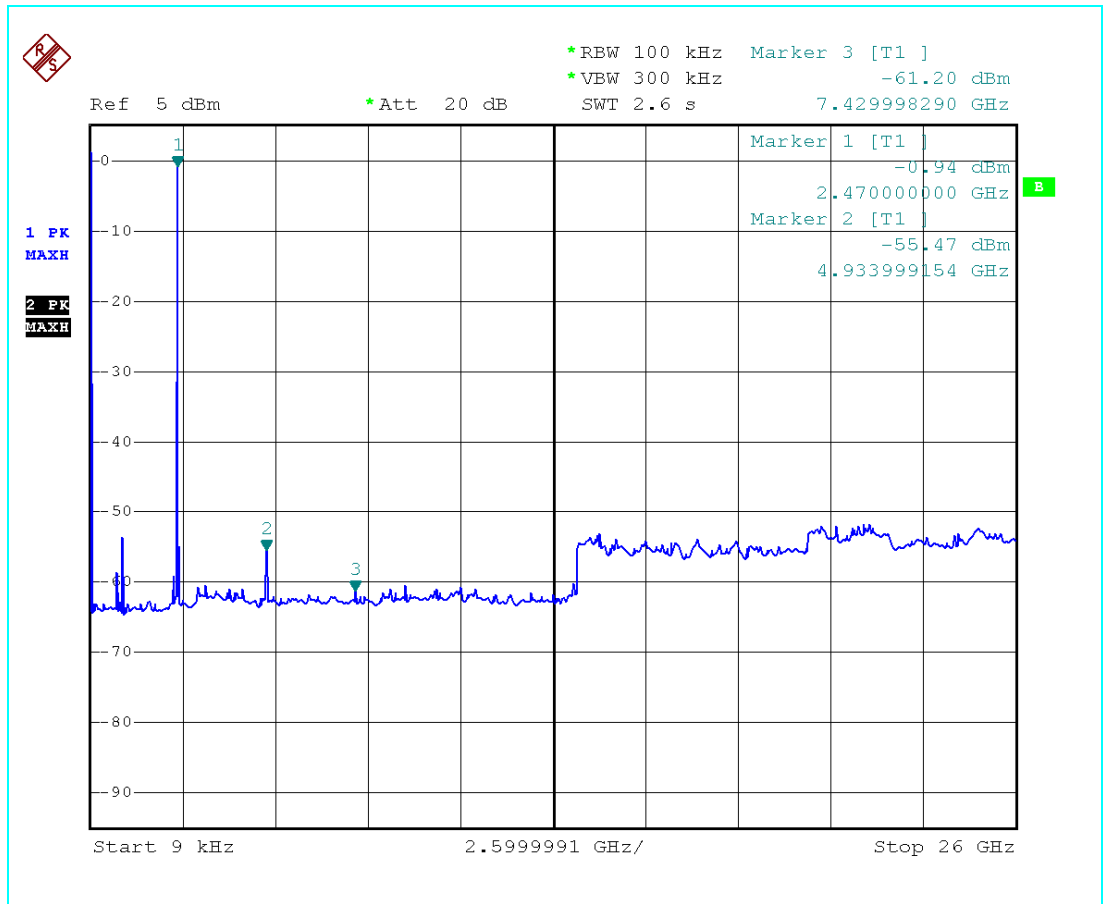

TEST No.8	Title	47CFR Part 15 Ref. Section
		“ Transmitter Power Spectral Density”
TEST SET-UP & REQUIREMENTS	Spectrum analyzer settings	
	Span	3 MHz
	Resolution (or IF) Bandwidth (RBW)	3 kHz
	Video (or Average) Bandwidth (VBW)	30 kHz
	Sweep time	340 ms
	Detector function	Peak
	Trace	max hold
	Attenuator	/
	LIMIT	8 dBm

The transmitter output was connected to the spectrum analyzer through a test fixture (radio frequency coupling device associated with the dedicated antenna of the equipment under test)

After trace stabilisation the marker shall be set on the signal peak. The indicated level is the power spectral density.

Test Result:

Channel (No.)	Power spectral density (dBm)	Plot (No.)
11	-6,31	1
20	-6,41	2
26	-7,00	3

Plot No. 1:

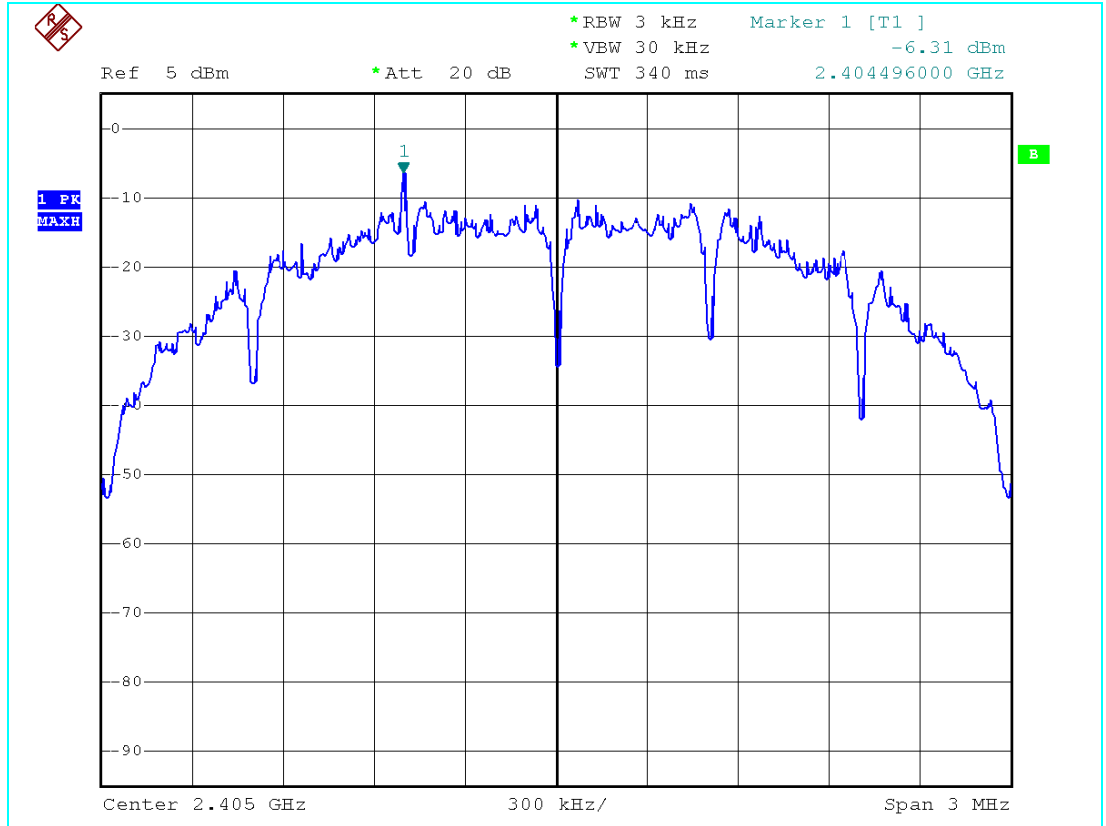

Plot No. 2:

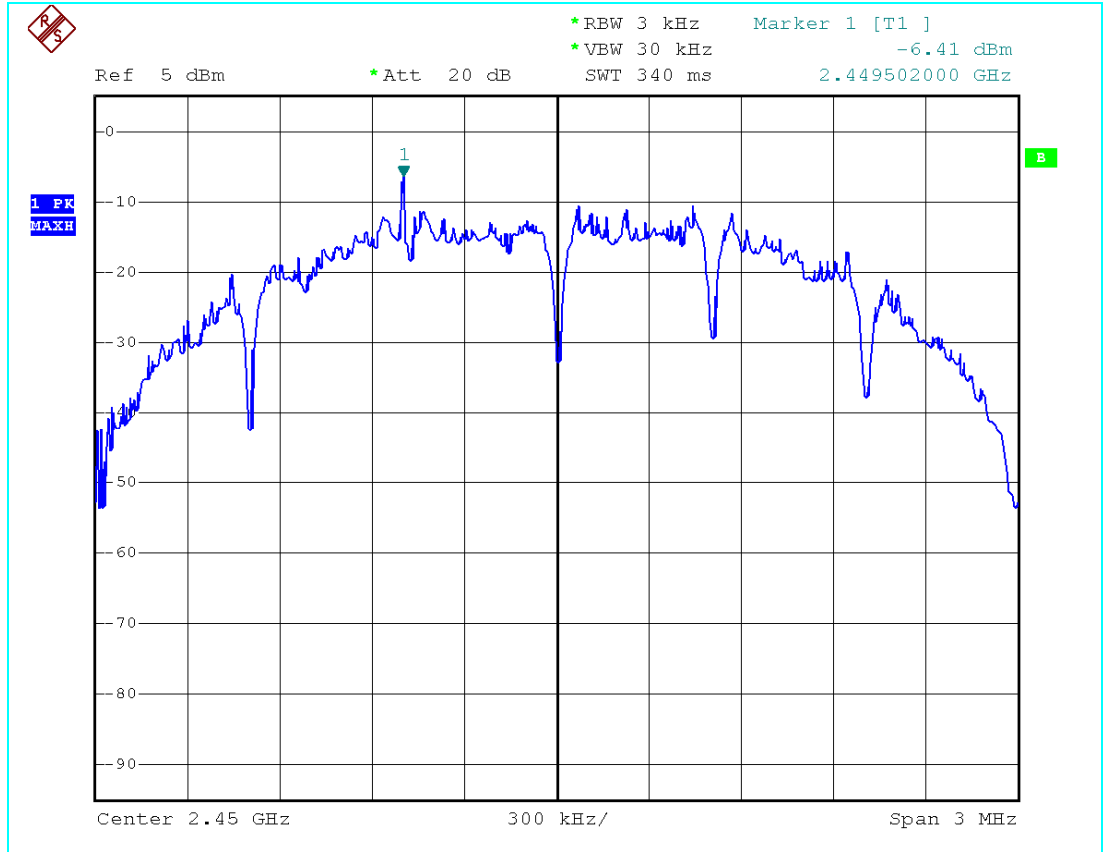

Plot No. 3:

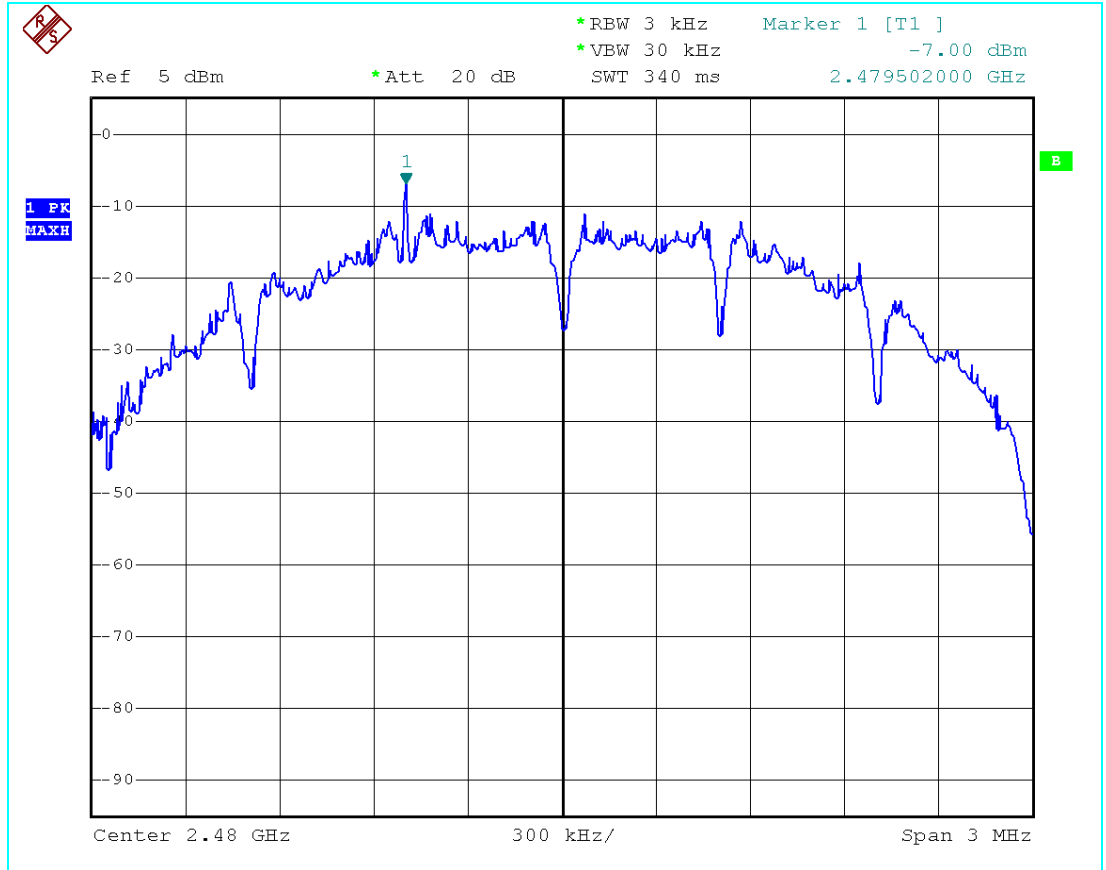

TEST No. 9	Title "RF Exposure Evaluation"	47CFR Part 15 Ref. Section
		15.247 (i)
TEST SET-UP & REQUIREMENTS	Systems operating under the provisions of this section shall be operated in a manner that ensures that the public is not exposed to radio frequency energy levels in excess of the Commission's guidelines. See § 1.1307(b)(1) of this Chapter.	
	EUT classification (fixed, mobile or portable devices)	Fixed, mobile or portable
	LIMITS	See table below

Limit for maximum permissible Exposure (MPE)

Frequency Range (MHz)	Electric Field Strength (E) (V/m)	Magnetic Field Strength (H) (A/m)	Power Density (S) (mW/cm ²)	Average Time (minutes)
(A) Limits for Occupational/Controlled Exposure				
0.3÷3.0	614	1.63	(100)*	6
3.0÷30	1842/f	4.89/f	(900/f ²)*	6
30÷300	61.4	0.163	1.0	6
300÷1500	--	--	f/300	6
1500÷100,000	--	--	5	6
(B) Limits for General Population/Uncontrolled Exposure				
0.3÷3.0	614	1.63	(100)*	30
3.0÷30	824/f	2.19/f	(180/f ²)*	30
30÷300	27.5	0.073	0.2	30
300÷1500	--	--	f/1500	30
1500÷100,000	--	--	1.0	30
F = Frequency in MHz *Plane-wave equivalent power density				

The distance from the device's transmitting antenna where the exposure level reaches the maximum permitted limit is calculated using the general equation:

$$S = P \cdot G / 4\pi R^2$$

Where:

S = Power Density (mW/cm²)

P = Conducted power (mW)

G = Linear power gain relative to isotropic radiator (numeric gain)

R = Distance (cm)

RF Exposure evaluation Distance:

Channel (No.)	Frequency (MHz)	Output power to antenna (dBm)	Power density @ 20 cm (mW/cm ²)	Distance where the exposure level reaches the limit (cm)	Limits (mW/cm ²)
11	2405,00	4,89	0,001	0,53	1
20	2450,00	4,49	0,001	0,50	1
26	2480,00	4,22	0,001	0,49	1

Test Result:

The EUT operates at low power level so it does not exceed the Commission's RF exposure guidelines limits; furthermore, Spread spectrum transmitters operate according to the Section 15.247 are categorically excluded from routine environmental evaluation.

RF exposure limit warning or SAR test are not required.

6 ADDITIONAL TECHNICAL INFORMATION

6.1 ELECTROMAGNETICALLY RELEVANT COMPONENTS:

Components	N°	Manufacturer	Type – Technical data
Radio Module			
See Technical document			
Host Equipment			
Test Jig		STM	/

6.2 RFI SUPPRESSION DEVICES:

Components	N°	Manufacturer	Type – Technical data
None			

6.3 EMI PROTECTION DEVICES:

Components	N°	Manufacturer	Type – Technical data
None			

7 TECHNICAL DOCUMENTATION

DOCUMENT	REFERENCE
Bill of materials	Doc n° D.PC851PR1-01.V01 Doc. Ref. PC851PR1
Electronic diagram	Doc n° E.PC847PR1-01.V01 Doc. Ref. PC847PR1
Radio Layout	Doc n° D.PC851PR1-02.V01 Doc. Ref. PC851PR1
Manual	SPZB250

8 PHOTOGRAPHIC DOCUMENTATION

8.1 EUT IDENTIFICATION

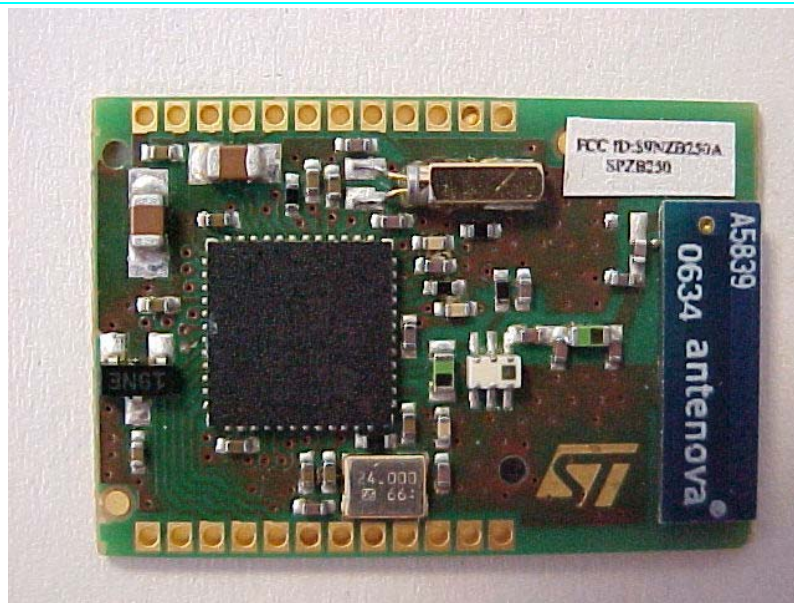

Radio module with ANTENNOVA antenna

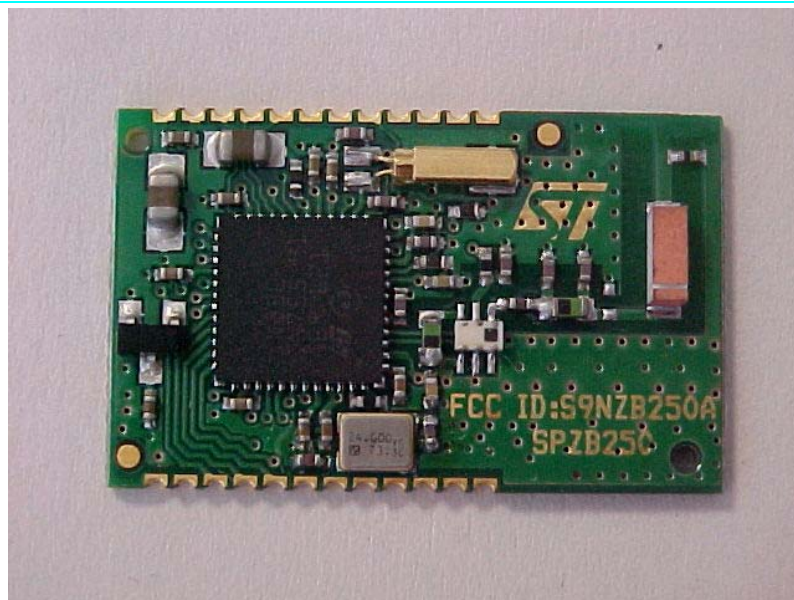

Radio module with MURATA antenna

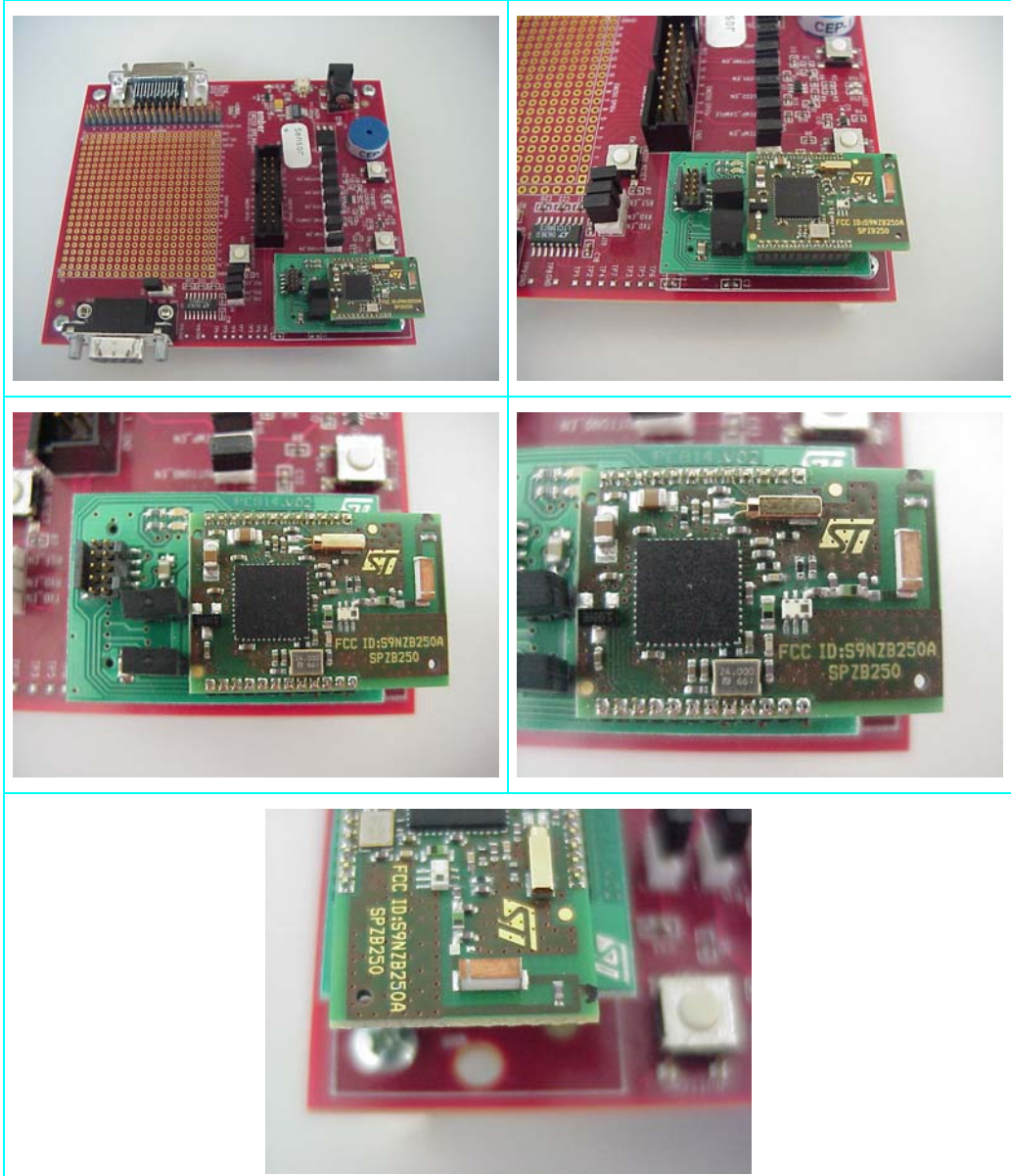

Equipment under test identification: Test jig + Radio module

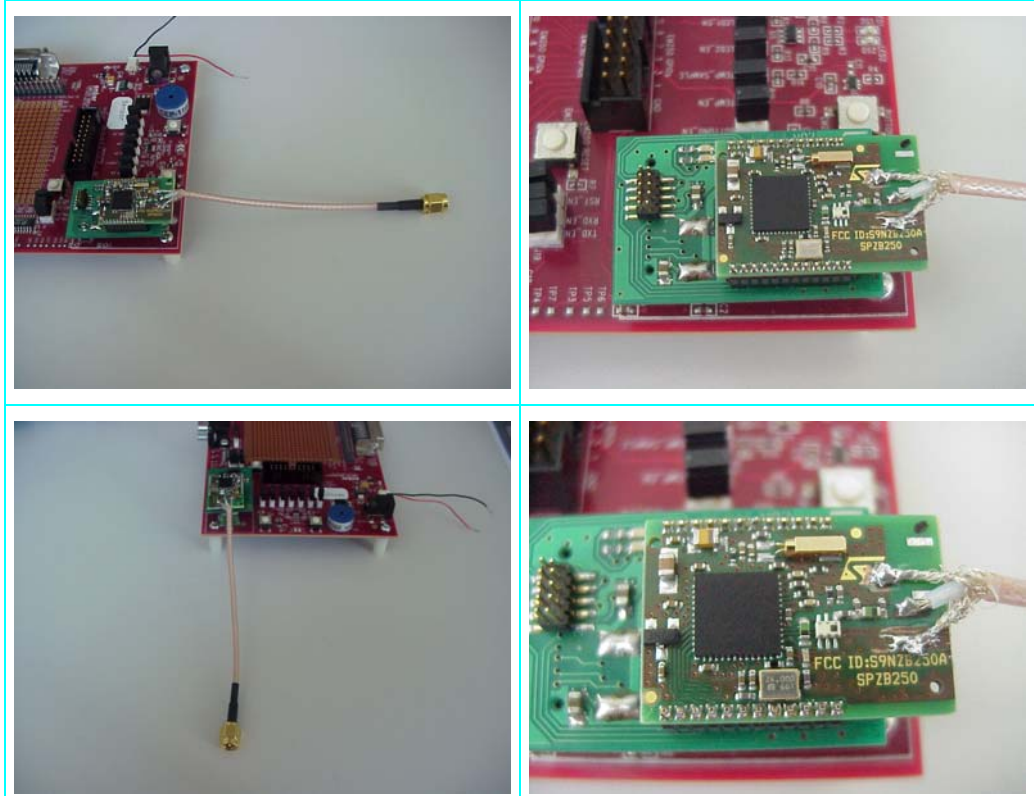

Radio module + antenna connector (for conducted spurious test)

8.2 TEST SET-UP

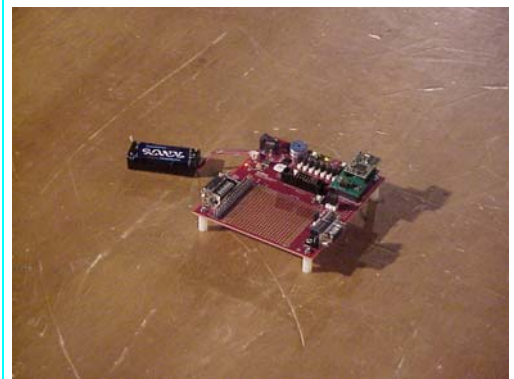
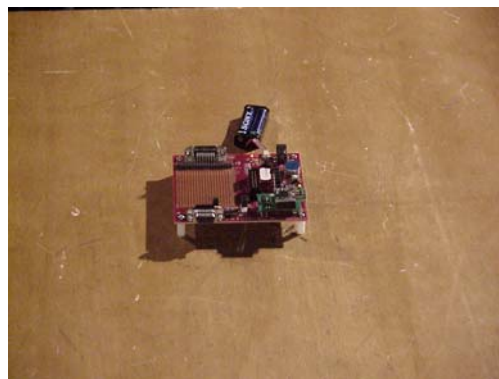

Set up of Radiated emission test

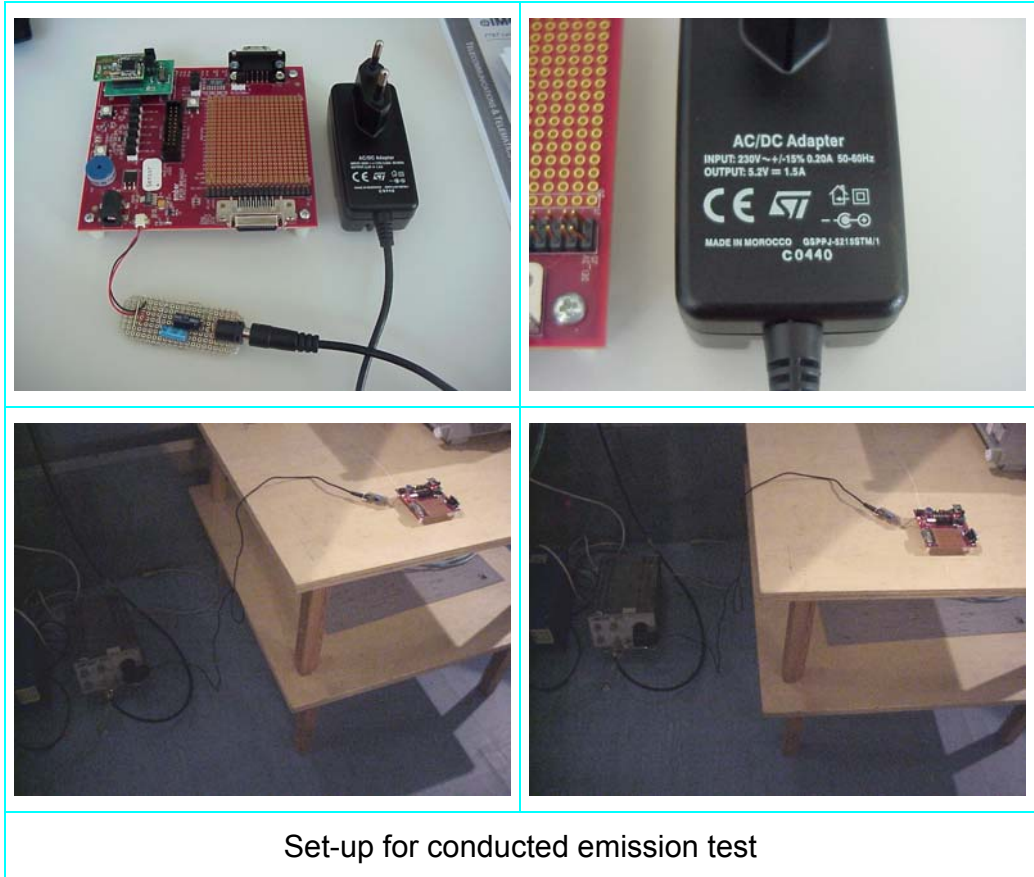

Set-up for conducted emission test

9 MEASUREMENT AND TEST EQUIPMENT INSTRUMENTATION

INSTRUMENTS	MANUFACTURER	MODEL	IMQ SERIAL NUMBER	Ref. TEST
Emi Receiver	Rohde & Schwarz	ESHS10	S-03494	2
Artificial Mains V-network	COMTEST	/	S-02405	2
Software for test automation	Rohde & Schwarz	ES-K1 V.1.60	-	2
Receiver/Spectrum analyzer	Rohde & Schwarz	ESMI	S-02349 + S-02350	3
Spectrum Analyzer	Rohde & Schwarz	FSP40	S-03629	3÷8
Power Meter	Hewlett Packard	HP 437B	S-03543	5
Antenna BilogP	ARA	LPD-2513	S-02385	3
Antenna ridged horn 1÷18 GHz	Schwarzbeck	BBHA9120D	S-03464	3
Antenna ridged horn 15÷40 GHz	Schwarzbeck	BBHA9170	S-03668	3
Pre-amplifier 30-1000MHz	Bonn Elektronik	BLNA 0110-15C35	S-04193	3
Pre-amplifier 1-26GHz	HP	HP 8449 B	S03542	3
Band Reject Filter 2400÷2483 MHz	Wainwright	WRCG2400/2483	S-04308	3
Highpass Filter 3.4÷18 GHz	Wainwright	WHK3.4/18	S-04309	3