



**Telecommunications & Telematics  
for Transports Lab.**

# TEST REPORT

Ref. No. ARSH00084

Date: 2007-05-28

Measurements performed in accordance with:



**FCC Rules : Code of Federal Regulations (CFR) no. 47 -  
PART 15 – RADIO FREQUENCY DEVICES**

PRODUCT : Bluetooth class 2 module board general purpose

TESTED MODEL : SPBT2425C2DB.xxx

FCC ID : S9N2425C2DB

APPLICANT : STMicroelectronics – Centro Direzionale Colleoni – Palazzo  
Andromeda 3 – I-20044 Agrate Brianza (MI) - ITALY

MANUFACTURER : STMicroelectronics – Centro Direzionale Colleoni – Palazzo  
Andromeda 3 – I-20044 Agrate Brianza (MI) - ITALY

TRADEMARK : STMicroelectronics

OTHER INFORMATION

Testing dates : 2007-05-02 ÷ 2007-05-03

Tested samples No. : 1

Testing Laboratory : IMQ S.p.A. Via Quintiliano, 43 I-20138 MILANO

Tested by : R. Radice Signature:  Date : 2007-05-28

Checked by: R. Colombo (EMC and R&TTE Lab. Deputy) Signature:  Date : 2007-05-28

## Revision Sheet

Release No.	Date	Revision Description
Rev. 0	2007-05-28	Test Results and Evaluation Report

NOTICE: The results of tests and checks reported in this Test Report refer exclusively to the samples tested and described in the Report itself.  
This report shall not be reproduced partially or in its entirety without the written approval of IMQ S.p.A.

**IMQ S.p.A. - Via Quintiliano, 43 – I-20138 MILANO**

# CONTENTS

<b>1</b>	<b>General Description of Equipment under Test .....</b>	<b>1-3</b>
1.1	APPLICANT .....	1-3
1.2	MANUFACTURER.....	1-3
1.3	EQUIPMENT CLASSIFICATION .....	1-3
1.4	BASIC DESCRIPTION OF EQUIPMENT UNDER TEST.....	1-4
1.5	FEATURE OF EQUIPMENT UNDER TEST .....	1-5
<b>2</b>	<b>Test Configuration of Equipment under Test .....</b>	<b>2-7</b>
2.1	ENVIRONMENTAL CONDITIONS .....	2-7
2.2	DESCRIPTION OF SUPPORT EQUIPMENT.....	2-7
2.3	INTERFACE IDENTIFICATION AND CONNECTION DIAGRAM OF TEST SYSTEM.....	2-8
<b>3</b>	<b>Operation of Equipment under Test .....</b>	<b>3-9</b>
3.1	OPERATING TEST CONDITIONS .....	3-9
<b>4</b>	<b>Tests Identification and Results .....</b>	<b>4-10</b>
4.1	METHODS OF MEASUREMENT .....	4-12
4.2	FREQUENCY RANGE INVESTIGATED .....	4-12
<b>5</b>	<b>Measurements and Tests Data.....</b>	<b>5-13</b>
<b>6</b>	<b>Additional Technical Information .....</b>	<b>6-49</b>
6.1	ELECTROMAGNETICALLY RELEVANT COMPONENTS:.....	6-49
6.2	RFI SUPPRESSION DEVICES: .....	6-49
6.3	EMI PROTECTION DEVICES: .....	6-49
<b>7</b>	<b>Technical Documentation.....</b>	<b>7-50</b>
<b>8</b>	<b>Photographic Documentation .....</b>	<b>8-51</b>
8.1	EUT IDENTIFICATION .....	8-51
8.2	TEST SET-UP .....	8-52
<b>9</b>	<b>Measurement and Test Equipment Instrumentation .....</b>	<b>9-53</b>

# 1 GENERAL DESCRIPTION OF EQUIPMENT UNDER TEST

---

## 1.1 APPLICANT

---

NAME	STMicroelectronics
ADDRESS	Centro Direzionale Colleoni – Palazzo Andromeda 3 – I-20044 Agrate Brianza (MI)
COUNTRY	ITALY

## 1.2 MANUFACTURER

---

NAME	STMicroelectronics
ADDRESS	Centro Direzionale Colleoni – Palazzo Andromeda 3 – I-20044 Agrate Brianza (MI)
COUNTRY	ITALY

## 1.3 EQUIPMENT CLASSIFICATION

---

According to the definition 15.3 (o) EUT is a **Frequency Hopping (Spread Spectrum) Intentional Radiator operating within the bands 2400-2483,5 MHz** so it shall fulfil provisions of 47CFR Part 15 Subpart C – Intentional radiators – and Section 15.247.

## 1.4 BASIC DESCRIPTION OF EQUIPMENT UNDER TEST

Parameters	Value
Type of equipment :	▪ Bluetooth module general purpose
Model :	▪ SPBT2425C2DB.xxx
FCC ID. :	▪ S9N2425C2DB
Trade Name	▪ STMicroelectronics
Data cable :	▪ /
Telecom cable :	▪ /
Power supply type :	▪ DC 5V, 40mA, 0.13Watt
AC power input cable :	▪ /
DC power input cable :	▪ /

## 1.5 FEATURE OF EQUIPMENT UNDER TEST

---

Power specification	▪ 5 V dc
Operating frequency:	▪ 2402 ÷ 2480 MHz (79 Channels)
Maximum RF output power:	▪ < 150 mW
Modulation:	▪ GFSK (FHSS)
Channel Spacing:	▪ 1 MHz
Antenna:	▪ Dedicated antenna (1 dBi gain) integrated in the test jig
Main SW identification	▪ /
Main HW Board identification	▪ /
Peripherals included (for system application)	▪ None
Interfaces :	▪ None
Integrated interfaces :	▪ None
AC adapter:	▪ None

**CHANNEL CONFIGURATION**

Channel (No.)	Frequency (MHz)	Channel (No.)	Frequency (MHz)	Channel (No.)	Frequency (MHz)
00	2402.00	28	2430.00	56	2458.00
01	2403.00	29	2431.00	57	2459.00
02	2404.00	30	2432.00	58	2460.00
03	2405.00	31	2433.00	59	2461.00
04	2406.00	32	2434.00	60	2462.00
05	2407.00	33	2435.00	61	2463.00
06	2408.00	34	2436.00	62	2464.00
07	2409.00	35	2437.00	63	2465.00
08	2410.00	36	2438.00	64	2466.00
09	2411.00	37	2439.00	65	2467.00
10	2412.00	38	2440.00	66	2468.00
11	2413.00	39	2441.00	67	2469.00
12	2414.00	40	2442.00	68	2470.00
13	2415.00	41	2443.00	69	2471.00
14	2416.00	42	2444.00	70	2472.00
15	2417.00	43	2445.00	71	2473.00
16	2418.00	44	2446.00	72	2474.00
17	2419.00	45	2447.00	73	2475.00
18	2420.00	46	2448.00	74	2476.00
19	2421.00	47	2449.00	75	2477.00
20	2422.00	48	2450.00	76	2478.00
21	2423.00	49	2451.00	77	2479.00
22	2424.00	50	2452.00	78	2480.00
23	2425.00	51	2453.00		
24	2426.00	52	2454.00		
25	2427.00	53	2455.00		
26	2428.00	54	2456.00		
27	2429.00	55	2457.00		

## 2 TEST CONFIGURATION OF EQUIPMENT UNDER TEST

---

### 2.1 ENVIRONMENTAL CONDITIONS

---

TEST CONDITIONS	MEASURED
Ambient Temperature	20 ÷ 25 °C
Relative Humidity	50 ÷ 60 %
Atmospheric Pressure	900 ÷ 1000 mbar

### 2.2 DESCRIPTION OF SUPPORT EQUIPMENT

---

Here following the details concerning equipment needed for correct operation or loading of the EUT:

EQUIPMENT	MANUFACTURER	MODEL
Personal Computer	IBM	-----
AC/DC Adapter	STMicroelectronics	GSPPJ-5215STM/1

## 2.3 INTERFACE IDENTIFICATION AND CONNECTION DIAGRAM OF TEST SYSTEM

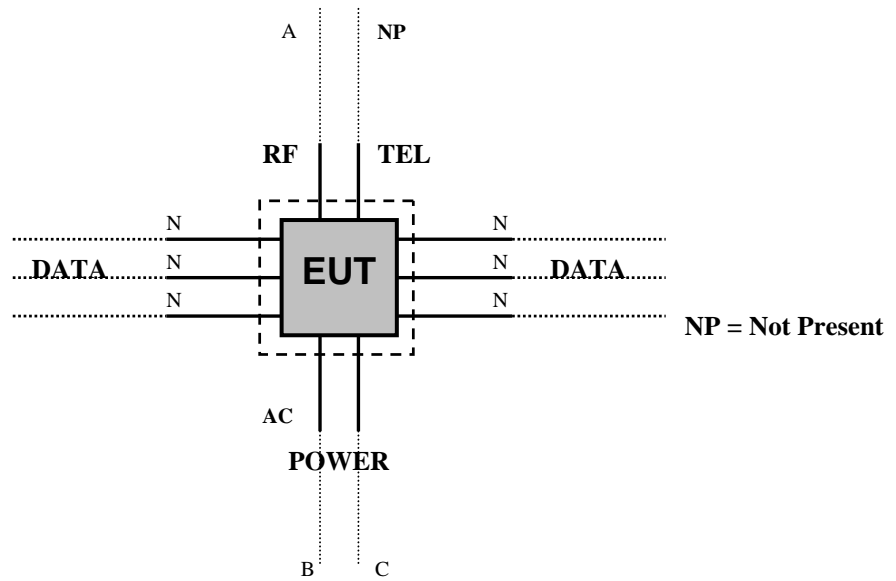

#	Interface	Description	Maximum length	Ref. Document
1	Enclosure	Open frame board	/	/
2	AC mains power input/output port	Port not present	/	/
3	DC power port	5V dc furnished on test jig board; Bluetooth module. 3.3 V dc	/	/
4	Signal / control port	RS232 connected to a test jig board USB port	/	/
5	Antenna port (RF)	Dedicated antenna (1 dBi gain) integrated in the test jig	/	/



## 3 OPERATION OF EQUIPMENT UNDER TEST

---

### 3.1 OPERATING TEST CONDITIONS

---

Ref.	Description
#1	Continuous transmission (sequential hopping transmission)
#2	Continuous transmission (single channel transmission)

## 4 TESTS IDENTIFICATION AND RESULTS

**TABLE 1 : SUMMARY OF TESTS**

CFR47 Part 15 Section	Title	Operating condition	Result	Test No.
15.203 15.247 (b)(4)(i)	Antenna Requirements	/	PASS	1
15.207 (a)	Conducted Emission	#1	PASS	2
15.209 (a) (f)	Radiated Emission	#2	PASS	3
15.247 (a)	Frequency Hopping Spread Spectrum Specifications			
15.247(a)(1)(iii)	Number of Hopping Channels Used	#1	PASS	4
15.247(a)	20 dB Bandwidth	#1	PASS	5
15.247(a)(1)	Carrier frequency (Hopping Channel) Separation	#1	PASS	6
15.247(a)(1)(iii)	Time occupancy (Dwell Time) of Each Channel (ch) within a $0,4 \times N_{ch}$ (sec) Period	#1	PASS	7
15.247(a)(2)	6dB Minimum Bandwidth	Not applicable		
15.247(b)	Maximum Peak Output Power			
15.247(b) (1)	Peak Output Power	#2	PASS	8
15.247(b) (4)	Antenna gain	Not applicable		
15.247(c)	Operation with directional antenna gains greater than 6 dBi	Not applicable		
15.247 (d)	100 kHz Bandwidth of Frequency Band Edges	#1 #2	PASS	9

15.247 (d)	Conducted Emission	#2	PASS	10
15.247 (e)	Power Spectral Density	#2	PASS	11
15.247 (f)	Hybrid systems	Not applicable		
15.247 (g)	FHSS Transmission characteristics	/	PASS	/
15.247 (h)	Recognition of occupied channel and multiple transmission system	Not applicable		
15.247(i) (§ 47CFR 1.1307(b)(1))	RF humane exposure	#2	PASS	12

## 4.1 METHODS OF MEASUREMENT

---

All compliance measurements have been carried out using the procedures described in the standard ANSI C63.4-2003 (excluding sub-par. 4.1.5.2, 5.7.9 and 14) and Section 15.31 of CFR47 Part 15 – Subpart A (General).

Additional test requirements have been adopted according to the reference Section indicated in the Test Table

## 4.2 FREQUENCY RANGE INVESTIGATED

---

- a. Conducted emission tests : from 150 kHz to 30 MHz.
- b. Radiated emission tests : from 30 MHz to tenth harmonic of fundamental

## 5 MEASUREMENTS AND TESTS DATA

TEST No. 1	Title "Antenna Requirements"	47CFR Part 15 Ref. Section <b>15.203 / 15.204</b>
<b>TEST REQUIREMENTS</b>	<p>An intentional radiator shall be designed to ensure that no antenna other than that furnished by the responsible party shall be used with the device. The use of a permanently attached antenna or of an antenna that uses a unique coupling to the intentional radiator shall be considered sufficient to comply with the provisions of this Section. The manufacturer may design the unit so that a broken antenna can be replaced by the user, but the use of a standard antenna jack or electrical connector is prohibited. This requirement does not apply to carrier current devices or to devices operated under the provisions of Sections 15.211, 15.213, 15.217, 15.219, or 15.221. Further, this requirement does not apply to intentional radiators that must be professionally installed, such as perimeter protection systems and some field disturbance sensors, or to other intentional radiators which, in accordance with Section 15.31(d), must be measured at the installation site. However, the installer shall be responsible for ensuring that the proper antenna is employed so that the limits in this Part are not exceeded.</p>	

Antenna specifications	
N° of authorized antenna types:	<ul style="list-style-type: none"> <li>▪ 1</li> </ul>
Antenna type :	<ul style="list-style-type: none"> <li>▪ Dedicated antenna integrated in the test jig</li> </ul>
Total gain :	<ul style="list-style-type: none"> <li>▪ 1 dBi</li> </ul>
External power amplifiers:	<ul style="list-style-type: none"> <li>▪ Not present</li> </ul>

### Test Result:

The transmitter meets the requirements of section 15.203 and 15.204

TEST No. 2	Title "Conducted emission"	47CFR Part 15 Ref. Section
		15.207
TEST REQUIREMENTS	Test setup	ANSI C63.4
	Limits of mains terminal disturbance voltage	15.207 (a)
	Frequency range	150 kHz – 30 MHz
	IF bandwidth	9 kHz
	EMC class	B

TEST DATA	PORT UNDER TEST	OPERATING CONDITION	RESULT
		AC mains power input port	#1
Note: In search of max noise (phase(s) and neutral). The measurements with Quasi-Peak detector are performed only for frequencies for which the Peak values are $\geq$ (Q.P. limit - 6 dB).			

**Test Result:**

Within the specifications

## MEASUREMENTS RESULTS

### CONDUCTED DISTURBANCE ON AC MAINS POWER PORT OF AC/DC ADAPTER

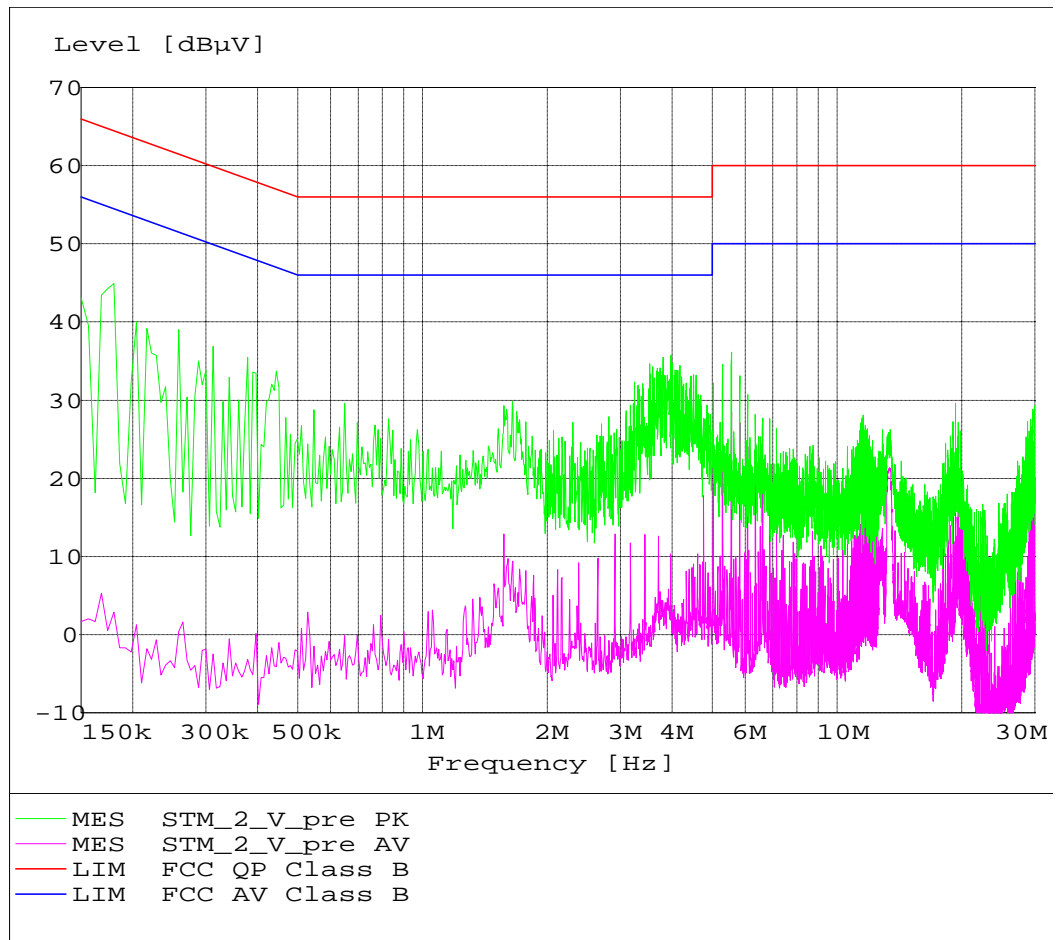

TEST No. 3	Title "Radiated disturbances"	47CFR Part 15 Ref. Section
		15.209
TEST REQUIREMENTS	Test setup	ANSI C63.4
	Test facility	Anechoic chamber
	Test distance	3 m
	Limits for radiated disturbances	15.209 (a)
	Frequency range	30 MHz to tenth harmonic of fundamental
	IF bandwidth (below 1000 MHz)	100 kHz
	IF bandwidth (above 1000 MHz)	1 MHz
	EMC class	B

	PORT UNDER TEST	OPERATING CONDITION	RESULT
TEST DATA	Enclosure	#2	Complies
	Note: In search of max noise (EUT rotation: from 0° to 360°; receiving antenna height: from 1 to 4m; receiving antenna polarization: horizontal and vertical). The measurements with Quasi-Peak detector, below 1000 MHz are performed only for frequencies for which the Peak values are $\geq$ (Q.P. limit - 6 dB).		

#### LIMITS FOR SPURIOUS

Band of operations	Peak (dB $\mu$ V/m)	Average Limit (dB $\mu$ V/m)
Restricted bands (par. 15.205)	74,00	54,00
Other bands	According to 15.209 or fundamental -20dB (which is greater)	According to 15.209 or fundamental -20dB (which is greater)



**MEASUREMENTS RESULTS (below 1000 MHz) – Vertical pol.**

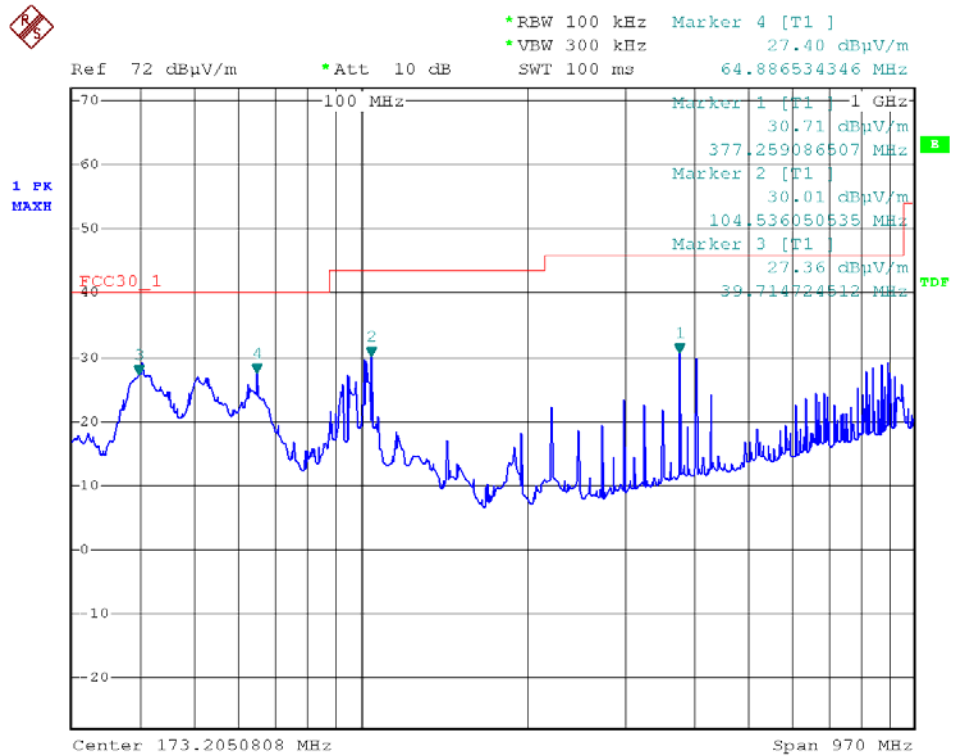

**PEAK RESULT**

Frequency (MHz)	Level (dBμV/m)	Limit (μVolt/meter)	Limit (dBμV/m)	Margin (dB)	Pol.
39,714	27,36	100	40,00	12,64	Vertical
64,886	27,40	100	40,00	12,60	Vertical
104,53	30,01	150	43,52	13,51	Vertical
377,25	30,71	200	46,02	15,49	Vertical

**MEASUREMENTS RESULTS (below 1000 MHz) – Horizontal pol.**

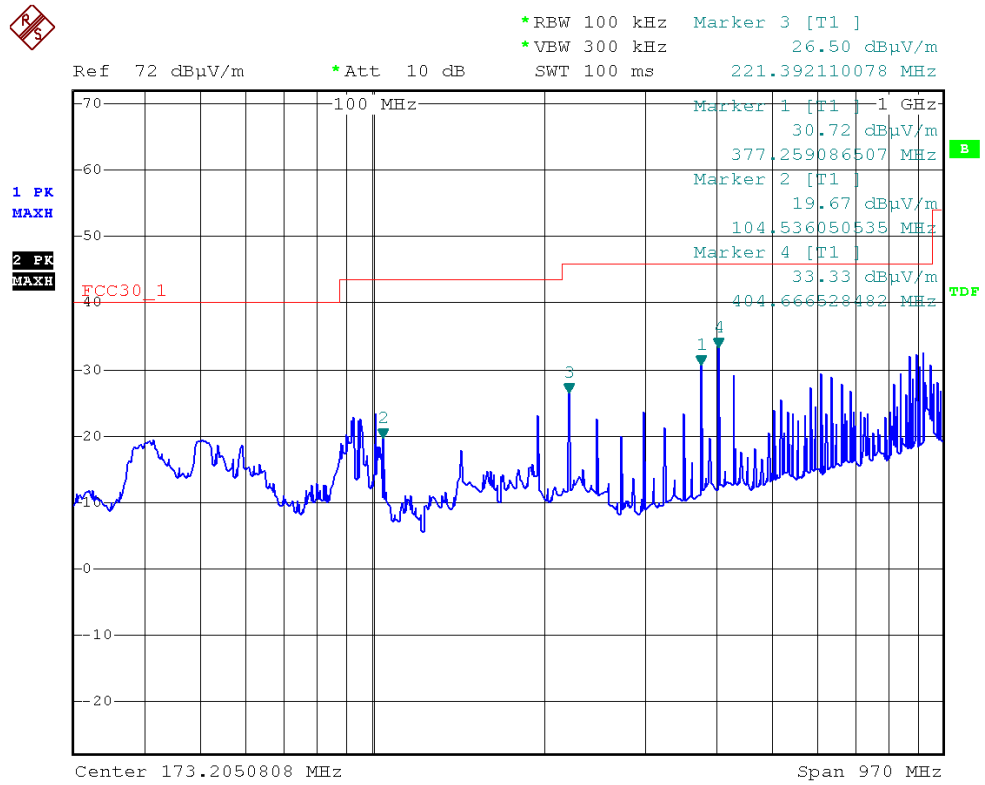

**PEAK RESULT**

Frequency (MHz)	Level (dBμV/m)	Limit (μVolt/meter)	Limit (dBμV/m)	Margin (dB)	Pol.
104,53	19,67	150	43,52	23,85	Horizontal
221,39	26,50	200	46,02	19,52	Horizontal
377,25	30,72	200	46,02	15,30	Horizontal
404,66	33,33	200	46,02	12,69	Horizontal

**MEASUREMENTS RESULTS (1000 MHz to 24800 MHz)**

Channel n°00: 2402,00 MHz

**PEAK DETECTOR**

Frequency (MHz)	Measured Level (dB $\mu$ V/m)	Limit ( $\mu$ Volt/meter)	Limit (dB $\mu$ V/m)	Margin (dB)
2389,11	45,26	5011,87	74,00	28,74
2401,84 (fundamental)	100,46	-----	-----	-----
2415,00	45,40	10543,86	80,46	35,06
4806,00	53,66	5011,87	74,00	20,34
7212,00	40,70	10543,86	80,46	39,76
f>8000	No spurious detected			

**AVERAGE FACTOR**

T. Pulse (ms)	TX on + TX off (ms)	Duty cycle	Average Factor (dB) 20log (0,34)
0,425	1,25	0,34	-9,37

**AVERAGE DETECTOR**

Frequency (MHz)	Measured Level (dB $\mu$ V/m)	Limit ( $\mu$ Volt/meter)	Limit (dB $\mu$ V/m)	Margin (dB)
2389,11	39,12	500	54,00	14,88
2401,84 (fundamental)	66,24	-----	-----	-----
2415,00	39,21	500	54,00	14,79
4806,00	47,55	500	54,00	6,45
7212,00	37,89	500	54,00	16,11
f>8000	No spurious detected			

Channel n°38: 2440,00 MHz

**PEAK DETECTOR**

Frequency (MHz)	Measured Level (dB $\mu$ V/m)	Limit ( $\mu$ Volt/meter)	Limit (dB $\mu$ V/m)	Margin (dB)
2440,16 (fundamental)	99,70	-----	-----	-----
4858,06	53,90	5011,87	74,00	20,10
4880,00	54,79	5011,87	74,00	19,21
7320,00	42,15	5011,87	74,00	31,85
f>8000	No spurious detected			

**AVERAGE FACTOR**

T. Pulse (ms)	TX on + TX off (ms)	Duty cycle	Average Factor (dB) 20log (0,34)
0,425	1,25	0,34	-9,37

**AVERAGE DETECTOR**

Frequency (MHz)	Measured Level (dB $\mu$ V/m)	Limit ( $\mu$ Volt/meter)	Limit (dB $\mu$ V/m)	Margin (dB)
2440,16 (fundamental)	72,28	-----	-----	-----
4858,06	43,48	500	54,00	10,52
4880,00	48,42	500	54,00	5,58
7320,00	35,57	500	54,00	18,43
f>8000	No spurious detected			

Channel n°78: 2480,00 MHz

**PEAK DETECTOR**

Frequency (MHz)	Measured Level (dB $\mu$ V/m)	Limit ( $\mu$ Volt/meter)	Limit (dB $\mu$ V/m)	Margin (dB)
2479,86 (fundamental)	98,60	-----	-----	-----
2492,94	43,87	5011,87	74,00	30,13
4931,00	51,52	5011,87	74,00	22,48
4960,00	54,29	5011,87	74,00	19,71
7440,00	43,16	5011,87	74,00	30,84
f>8000	No spurious detected			

**AVERAGE FACTOR**

T. Pulse (ms)	TX on + TX off (ms)	Duty cycle	Average Factor (dB) 20log (0,34)
0,425	1,25	0,34	-9,37

**AVERAGE DETECTOR**

Frequency (MHz)	Measured Level (dB $\mu$ V/m)	Limit ( $\mu$ Volt/meter)	Limit (dB $\mu$ V/m)	Margin (dB)
2479,86 (fundamental)	72,28	-----	-----	-----
2492,94	38,79	500	54,00	15,21
4931,00	40,75	500	54,00	13,25
4960,00	50,54	500	54,00	3,46
7440,00	36,21	500	54,00	17,79
f>8000	No spurious detected			

TEST No.4	Title		47CFR Part 15 Ref. Section
	“ Number of Hopping Frequencies”		15.247 (a) (1) (iii)
<b>TEST SET-UP &amp; REQUIREMENTS</b>	<b>Spectrum analyzer settings</b>		
	Span	Assigned frequency band	
	Resolution (or IF) Bandwidth (RBW)	100 kHz	
	Video (or Average) Bandwidth (VBW)	100 kHz	
	Sweep time	10 ms	
	Detector function	Peak	
	Trace	max hold	
	Attenuator	/	
	<b>LIMIT</b>	<b>&gt; 15</b>	

The transmitter output was connected to the spectrum analyzer through a test fixture (radio frequency coupling device associated with the dedicated antenna of the equipment under test)

Once the trace is stabilized, by the marker-delta function the separation between the peaks of the adjacent channels was determined detect all hopping frequencies

**Test Result:**

Number of measured Hopping Frequency channels (No.)	Plot (No.)
79	1

**Modification during the test:**

- none

**Plot No. 1:**

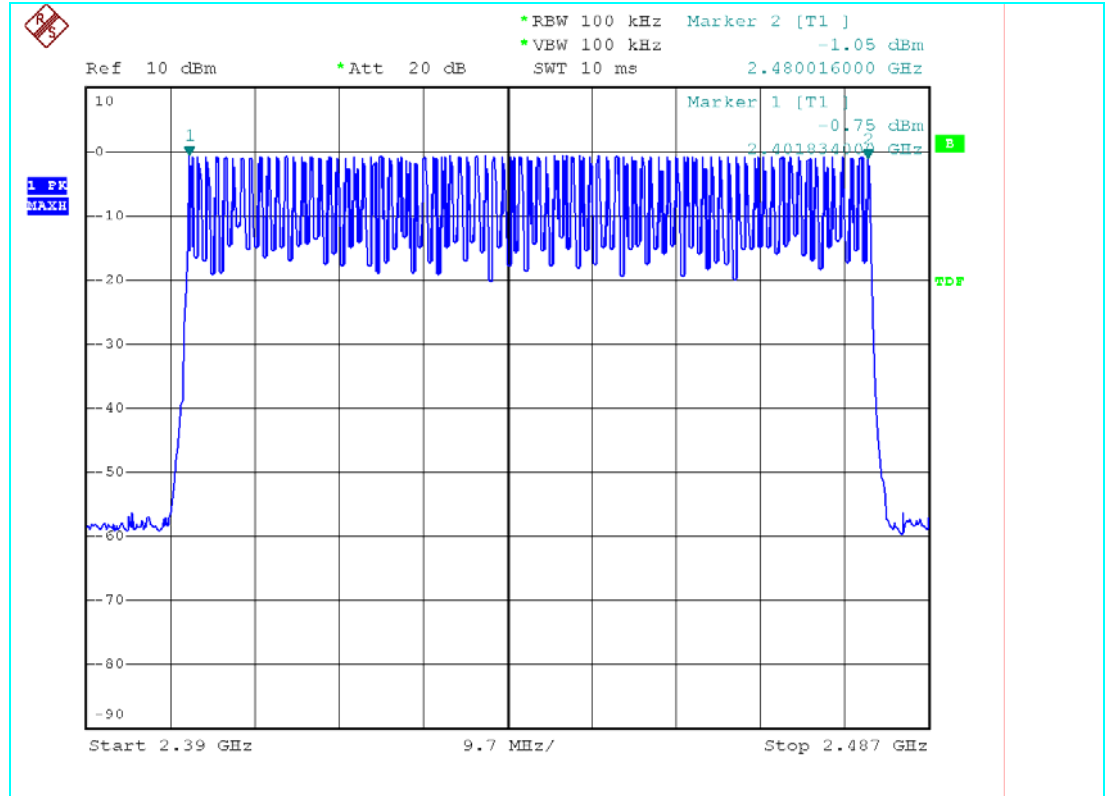

TEST No.5	Title "20 dB Bandwidth"	47CFR Part 15 Ref. Section
<b>TEST SET-UP &amp; REQUIREMENTS</b>	<b>Spectrum analyzer settings</b>	
	Span	3 MHz
	Resolution (or IF) Bandwidth (RBW)	100 kHz
	Video (or Average) Bandwidth (VBW)	300 kHz
	Sweep time	100 ms
	Detector function	Peak
	Trace	max hold
	Attenuator	/
	<b>LIMIT</b>	-----

The EUT is set to transmit has its maximum data rate.

The transmitter output was connected to the spectrum analyzer through a test fixture (radio frequency coupling device associated with the dedicated antenna of the equipment under test)

The Hopping Channel bandwidth is defined as the total spectrum the power of which is higher than peak power minus 20 dB.

#### Test Result:

Channel (No.)	Frequency (MHz)	Hopping Channel Bandwidth (kHz)	Plot (No.)
00	2402,00	1134	1
38	2440,00	1140	2
78	2480,00	1134	3

#### Modification during the test:

- none



Plot No. 1÷3:

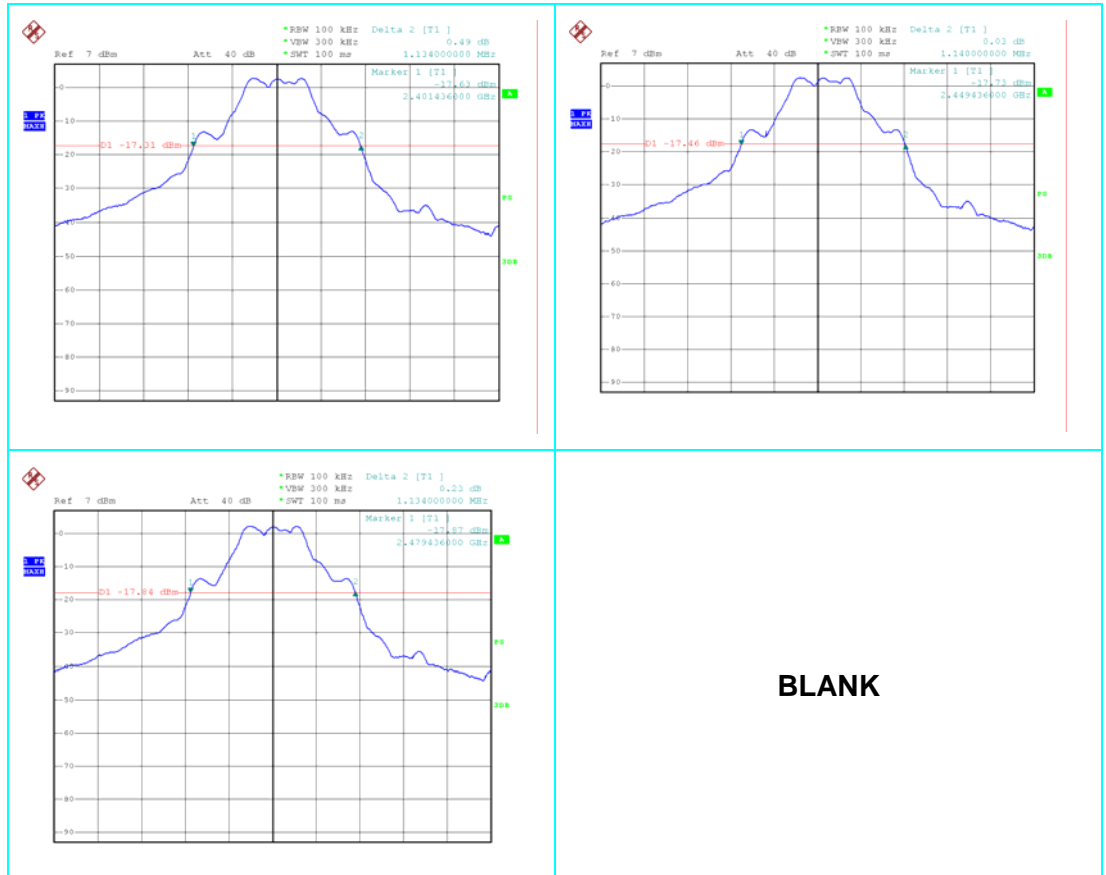

BLANK

TEST No.6	Title “ Carrier Frequency Separation & hopping system requirements”		47CFR Part 15 Ref. Section
			15.247 (a) (1)
<b>TEST SET-UP &amp; REQUIREMENTS</b>	<b>Spectrum analyzer settings</b>		
	Span	3 MHz (wide enough to capture the peaks of two adjacent channels)	
	Resolution (or IF) Bandwidth (RBW)	100 kHz	
	Video (or Average) Bandwidth (VBW)	300 kHz	
	Sweep time	2.5 ms	
	Detector function	Peak	
	Trace	max hold	
	Attenuator	/	
	<b>LIMIT</b>	<b>&gt;25 kHz</b>	

The transmitter output was connected to the spectrum analyzer through a test fixture (radio frequency coupling device associated with the dedicated antenna of the equipment under test)

The Hopping Channel Separation is defined as the channel is separated with the next channel.

Once the trace is stabilized, by the marker-delta function the separation between the peaks of the adjacent channels was determined

#### Test Result:

Channel (No.)	Frequency (MHz)	Hopping Channel Separation (KHz)	Plot (No.)
00	2402,00	996	1
38	2440,00	1008	2
78	2480,00	996	3

**Hopping System Requirements:**

Requirements	Result
The system hop to channel frequencies that are selected at the system hopping rate from a pseudorandomly ordered listed of hopping frequencies.	COMPLY
Each system frequency is used equally on the average by the transmitter.	COMPLY
The system receivers have input bandwidths that match the hopping channel bandwidths of this transmitter and shift frequencies in synchronization with the transmitted signals.	COMPLY

**Test Result:**

Within the specifications

**Plot No. 1:**

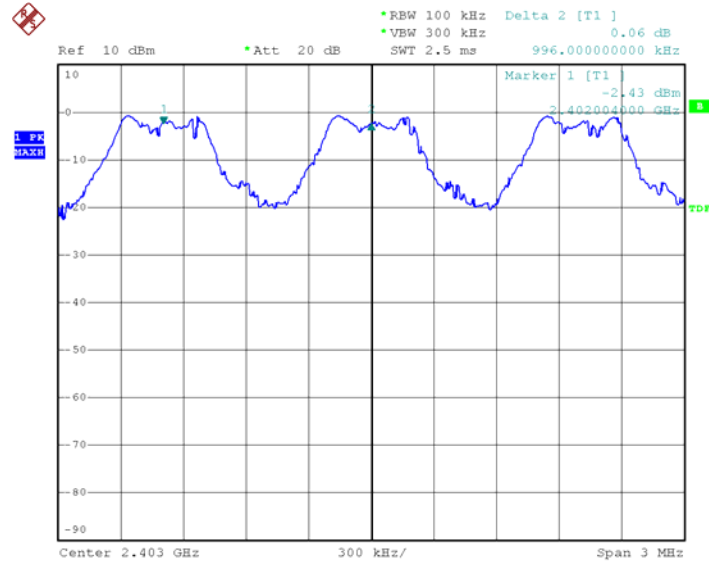

**Plot No. 2:**

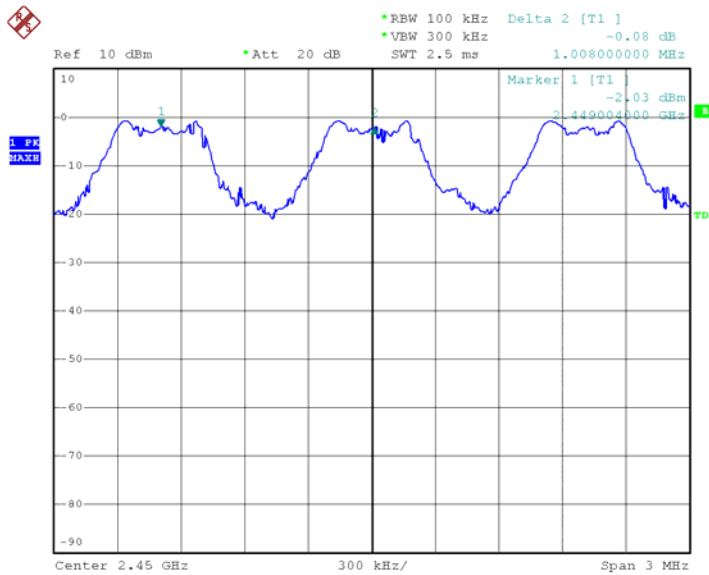

Plot No. 3:

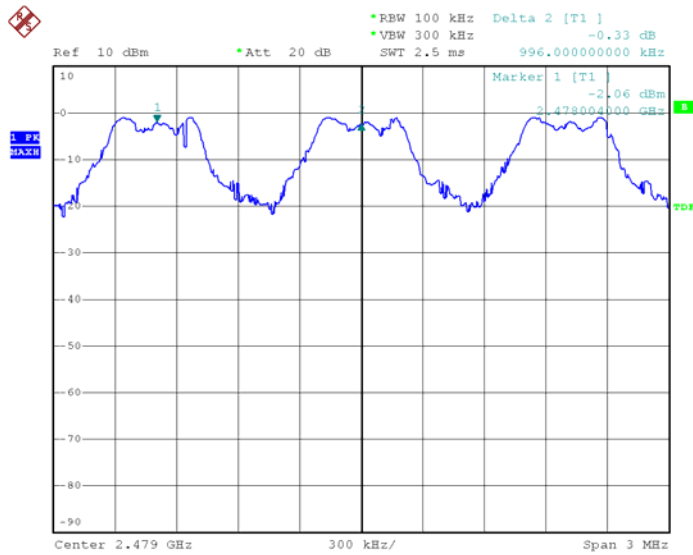

TEST No.7	Title “ Time of Occupancy (Dwell Time)”	47CFR Part 15 Ref. Section <b>15.247 (a) (1) (iii)</b>
<b>TEST SET-UP &amp; REQUIREMENTS</b>	<b>Spectrum analyzer settings</b>	
	Span	zero span, centered on a hopping channel
	Resolution (or IF) Bandwidth (RBW)	3 MHz
	Video (or Average) Bandwidth (VBW)	3 MHz
	Sweep time	5 ms
	Detector function	Peak
	Trace	max hold
	Attenuator	/
	<b>LIMIT</b>	<b>&lt; 0.4 seconds within a 0,4 seconds period multiplied by the number of hopping channels employed.</b>

The transmitter output was connected to the spectrum analyzer through a test fixture (radio frequency coupling device associated with the dedicated antenna of the equipment under test)

The video out of spectrum analyzer is connected to an Oscilloscope and a Counter to define the average time of occupancy on a selected frequency.

Once the trace is stabilized, by the marker-delta function determine the dwell time was determined

The Dwell time is calculated with the following formula:

**Dwell time = duration pulse x n° hops / number of channels x 31.6 sec.**

Duration pulse: measured pulse time (see plot of spectrum analyzer)

N° hops: n° of hops per second in the actual operating mode of the transmitter (for this equipment number of hops are 1600)

N° of channel: the system uses 79 channels

31,6 sec: 0,4sec multiplied by the number of hopping channel (79)

With the used hopping mode (DH1) a packet need 1 timeslots for transmitting and the next timeslot for receiving. So the system makes in worst case 800 hops per second in transmit mode.

**Test Result (DH1 time slot):**

Channel (No.)	Frequency (MHz)	Pulse duration (ms)	Dwell Time (sec.)	Plot (No.)
00	2402,00	0,411	0,131	1
38	2440,00	0,411	0,131	/
78	2480,00	0,411	0,131	/

**Plot 1:**

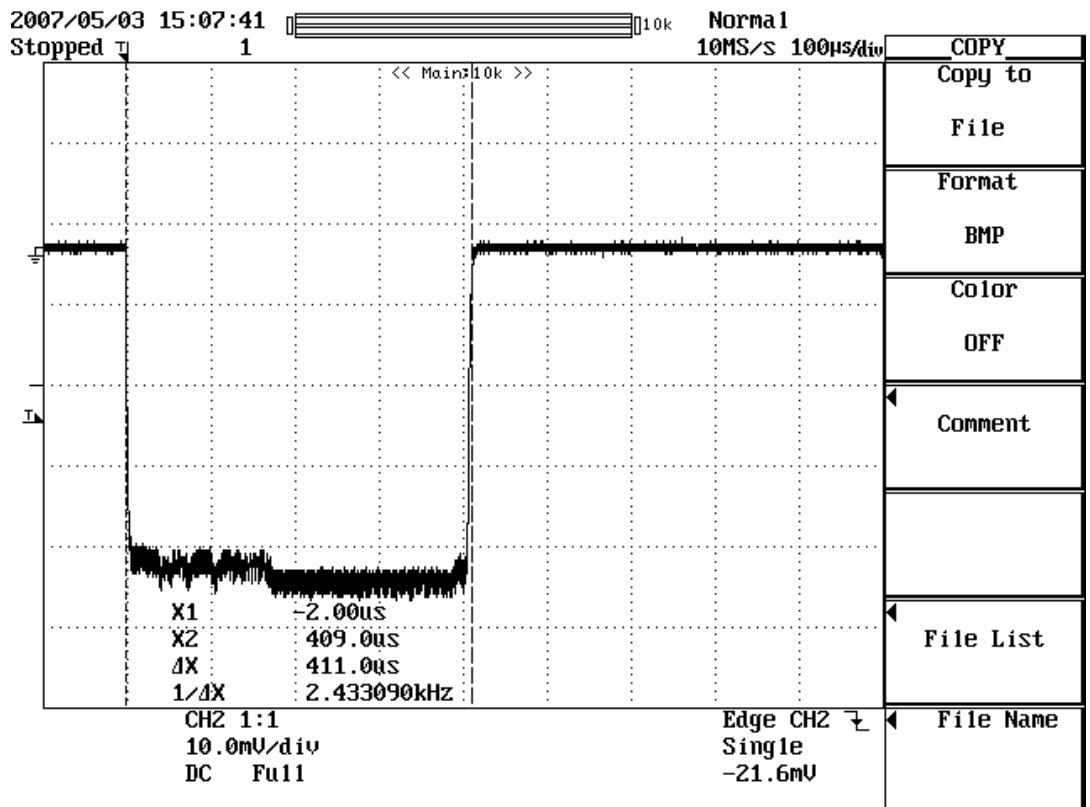

TEST No.8	Title		47CFR Part 15 Ref. Section
	“ Maximum Peak Output Power with External Antenna (De Facto EIRP)”		<b>15.247 (b) (1)</b>
<b>TEST SET-UP &amp; REQUIREMENTS</b>	<b>Spectrum analyzer settings</b>		
	Span	10 MHz	
	Resolution (or IF) Bandwidth (RBW)	3 MHz	
	Video (or Average) Bandwidth (VBW)	3 MHz	
	Sweep time	as necessary to capture the entire dwell time per hopping channel	
	Detector function	Peak	
	Trace	max hold	
	Attenuator	/	
	<b>LIMIT</b>	<b>125 mW</b>	

The EUT has its hopping function enabled.

**Conducted measurements:**

The transmitter output was connected to the spectrum analyzer via a low loss cable.



**Test Result: Conducted measure (peak detector)**

<b>Channel (No.)</b>	<b>Frequency (MHz)</b>	<b>Measured Output Power (mW)</b>
00	2402,00	2,328
38	2440,00	2,307
78	2480,00	2,229

**Modification during the test:**

- none

TEST No. 9	Title “Band-edge Compliance of RF Conducted Emissions “		47CFR Part 15 Ref. Section
			<b>15.247 (d)</b>
<b>TEST SET-UP &amp; REQUIREMENTS</b>	<b>Spectrum analyzer settings</b>		
	Span	Wide enough to capture the peak level of the emission operating on the channel closest to the band edge, as well as any modulation products which fall outside of the authorized band of operation	
	Resolution (or IF) Bandwidth (RBW)	100 kHz	
	Video (or Average) Bandwidth (VBW)	100 kHz	
	Sweep time	Auto	
	Detector function	Peak	
	Trace	Max hold	
	Attenuator	/	
	<b>LIMIT</b>	<b>&gt; 20 dB below that in the 100 kHz bandwidth within the assigned band</b>	

The transmitter output was connected to the spectrum analyzer through a test fixture (radio frequency coupling device associated with the dedicated antenna of the equipment under test)

Once the trace is stabilized, by the marker the emission at the band edge (or on the highest modulation product outside of the band, if this level is greater than that at the band edge) was set.

The n by the marker-delta function and the marker-to-peak function the peak of the in-band emission was selected. The marker-delta value displayed was compared with the limit specified in this Section.

**Test Result:**

**Band-edge compliance, lower band edge, hopping off**

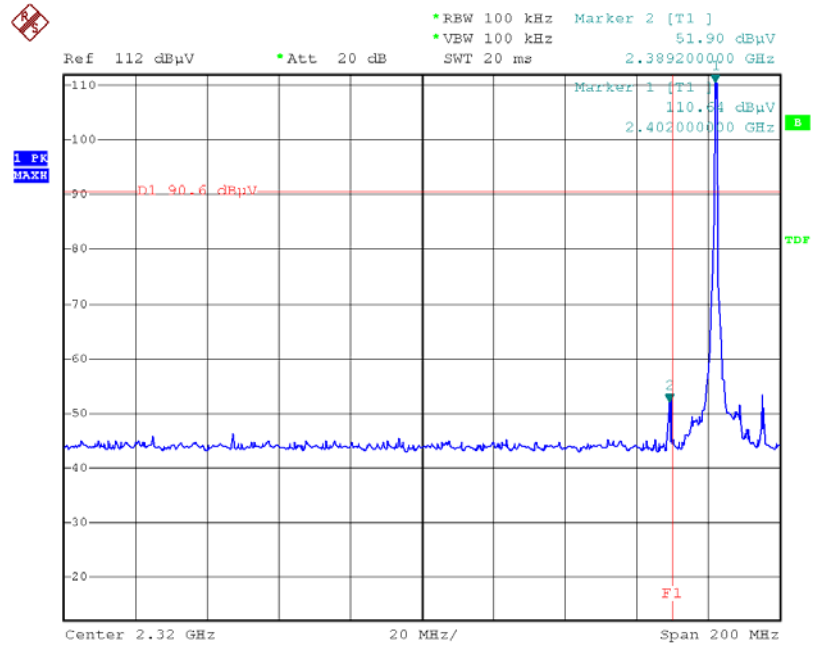

**Band-edge compliance, upper band edge, hopping off**

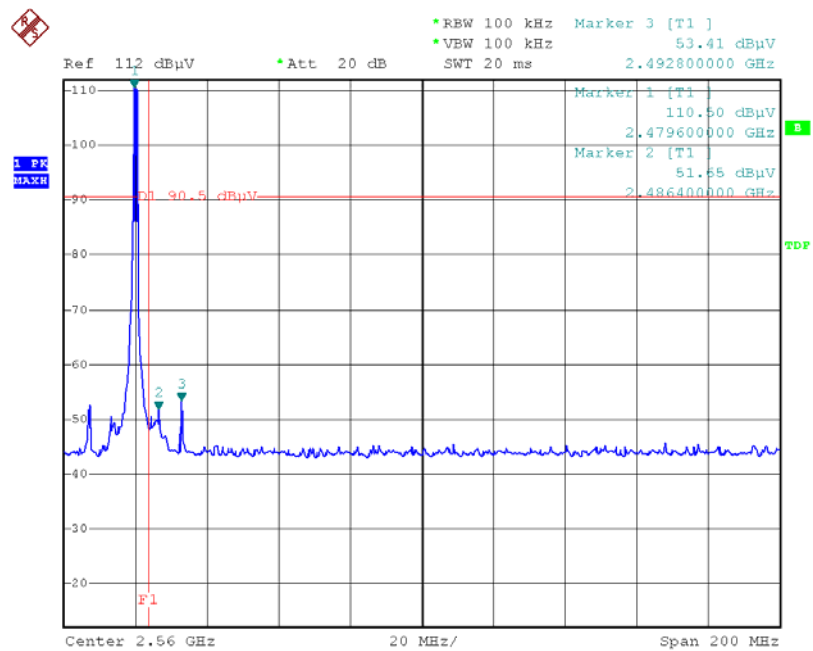

**Band-edge compliance, lower band edge, hopping on**

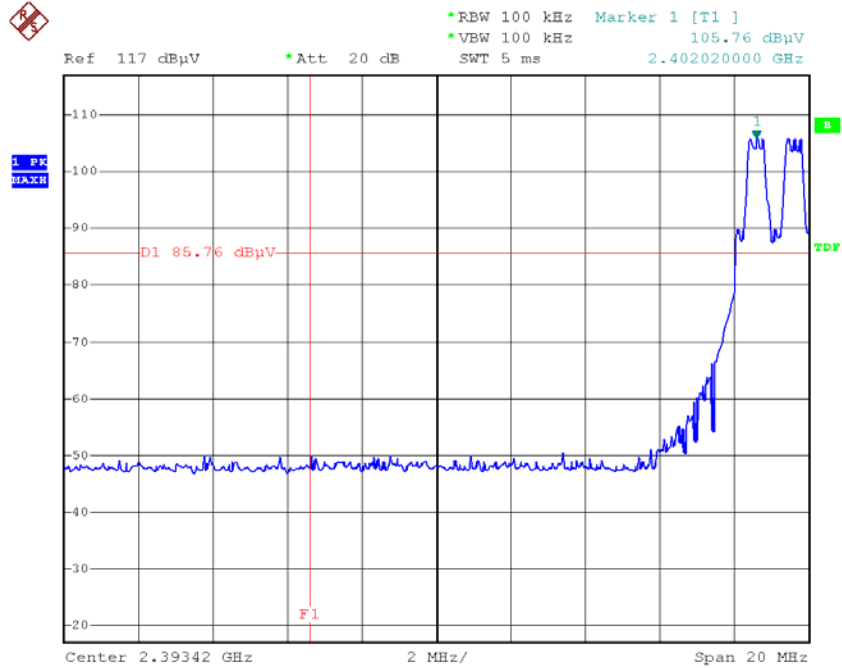

**Band-edge compliance, upper band edge, hopping on**

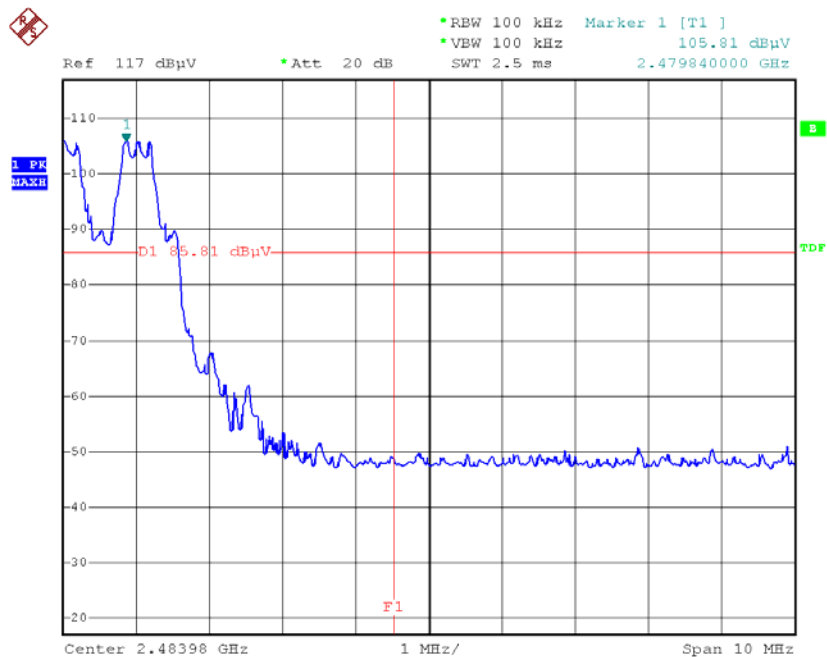

TEST No.10	Title “ Conducted emission”		47CFR Part 15 Ref. Section
			<b>15.247 (d)</b>
<b>TEST SET-UP &amp; REQUIREMENTS</b>	<b>Spectrum analyzer settings</b>		
	Span	1 MHz	
	Resolution (or IF) Bandwidth (RBW)	100 kHz	
	Video (or Average) Bandwidth (VBW)	100 kHz	
	Sweep time	as necessary to capture the entire dwell time per hopping channel	
	Detector function	Peak	
	Trace	max hold	
	Attenuator	/	
	<b>LIMIT</b>	<b>20 dB below from Conducted peak of RF</b>	

The EUT has to be connected to the spectrum analyser via a low loss cable. If the EUT is not equipped with an antenna connector, a temporary antenna connector has to be installed. The EUT has to be switched on and the hopping function has to be disenabled.

**Test Result: Conducted measure (channel 00)**

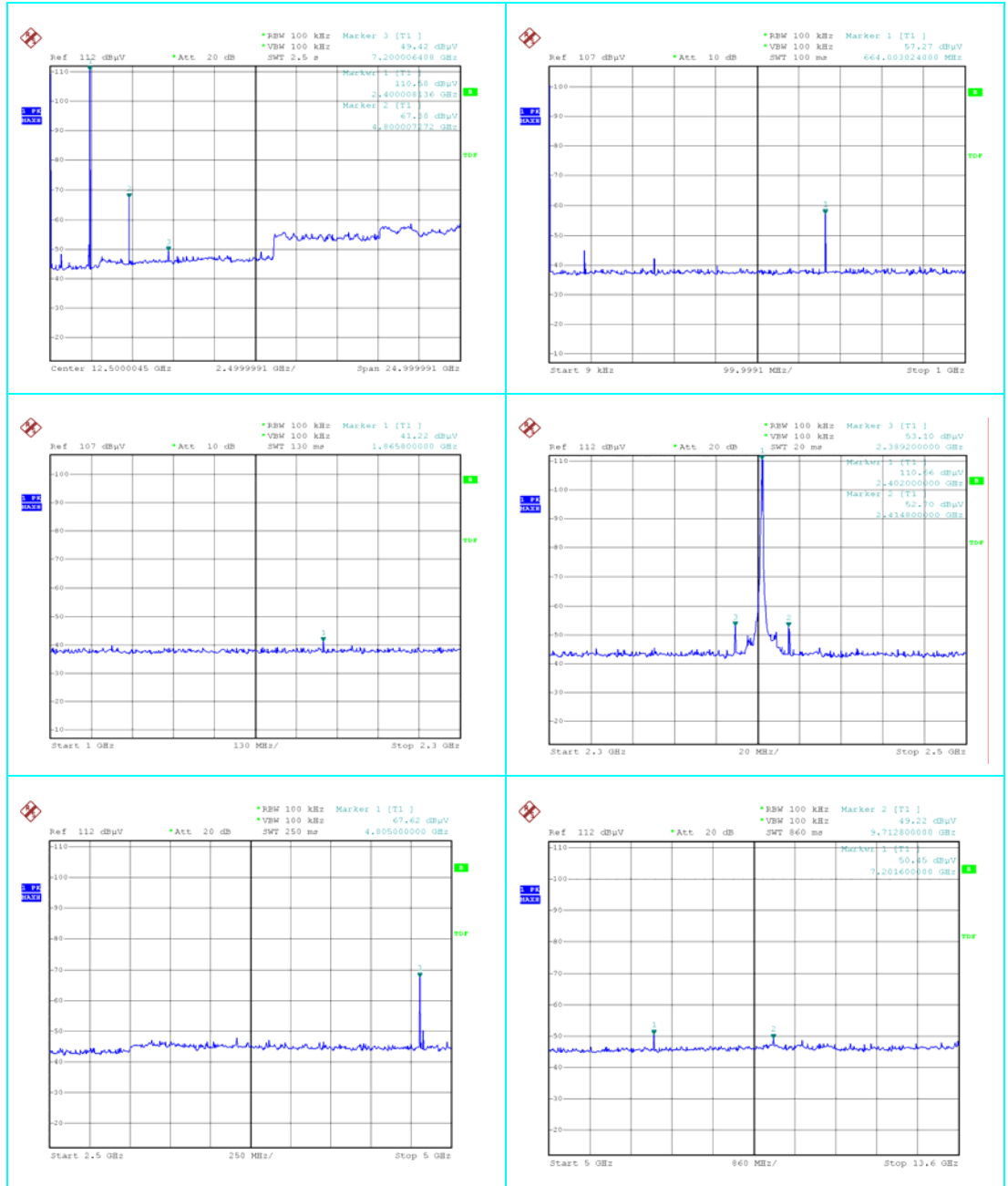

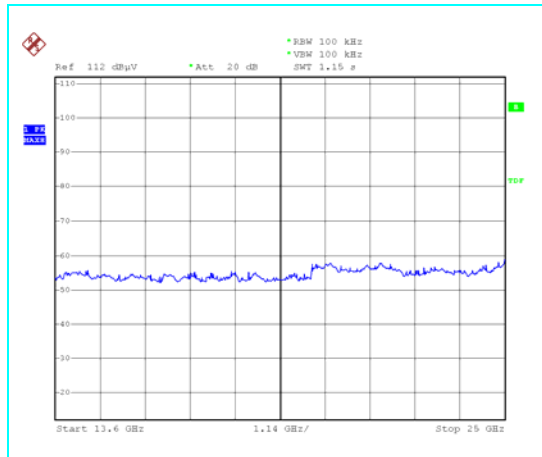

**BLANK**

Channel n°00: 2402,00 MHz

**PEAK RESULT**

Frequency (MHz)	Measured spurious (dBμV)	Limit (dBμV)	Margin (dB)
664,00	57,27	90,66	33,39
1865,00	41,22	90,66	49,44
2389,20	53,10	90,66	37,56
2402 (fundamental)	110,66	-----	-----
2414,80	52,70	90,66	37,96
4805,00	67,22	90,66	23,44
7201,60	50,45	90,66	40,21
9712,80	49,22	90,66	41,44

### Conducted measure (channel 48)

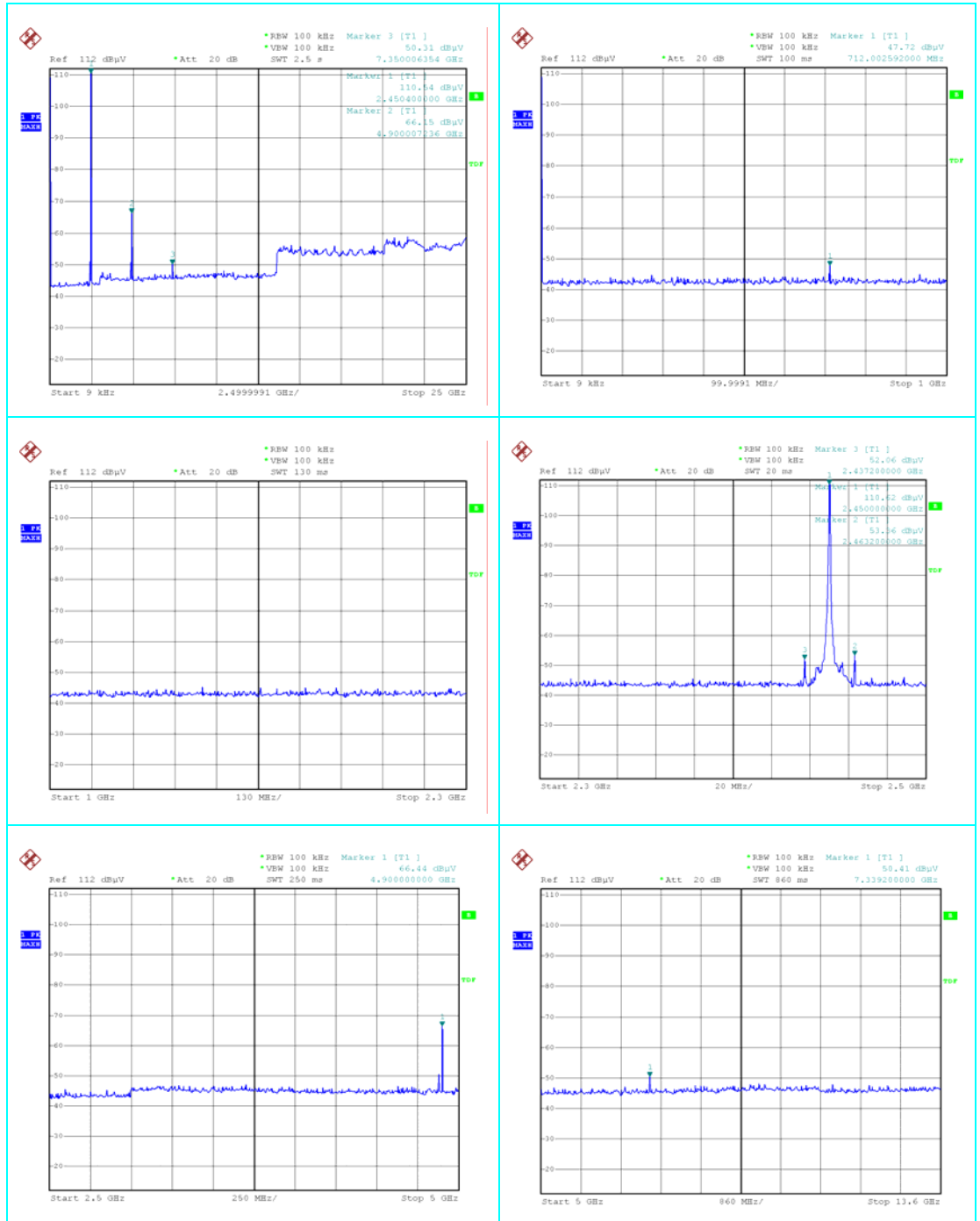



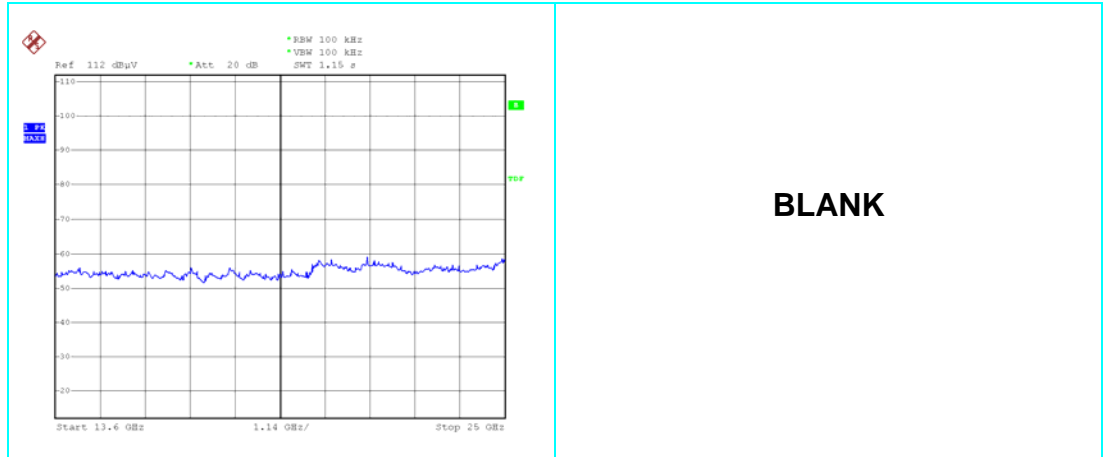

Channel n°48: 2450,00 MHz

**PEAK RESULT**

Frequency (MHz)	Measured spurious (dBμV)	Limit (dBμV)	Margin (dB)
712,00	47,72	90,52	42,80
2437,20	52,06	90,52	40,46
2450 (fundamental)	110,52	-----	-----
2463,20	53,36	90,52	37,16
4900,00	66,44	90,52	24,08
7339,20	50,41	90,52	40,11

### Conducted measure (channel 78)

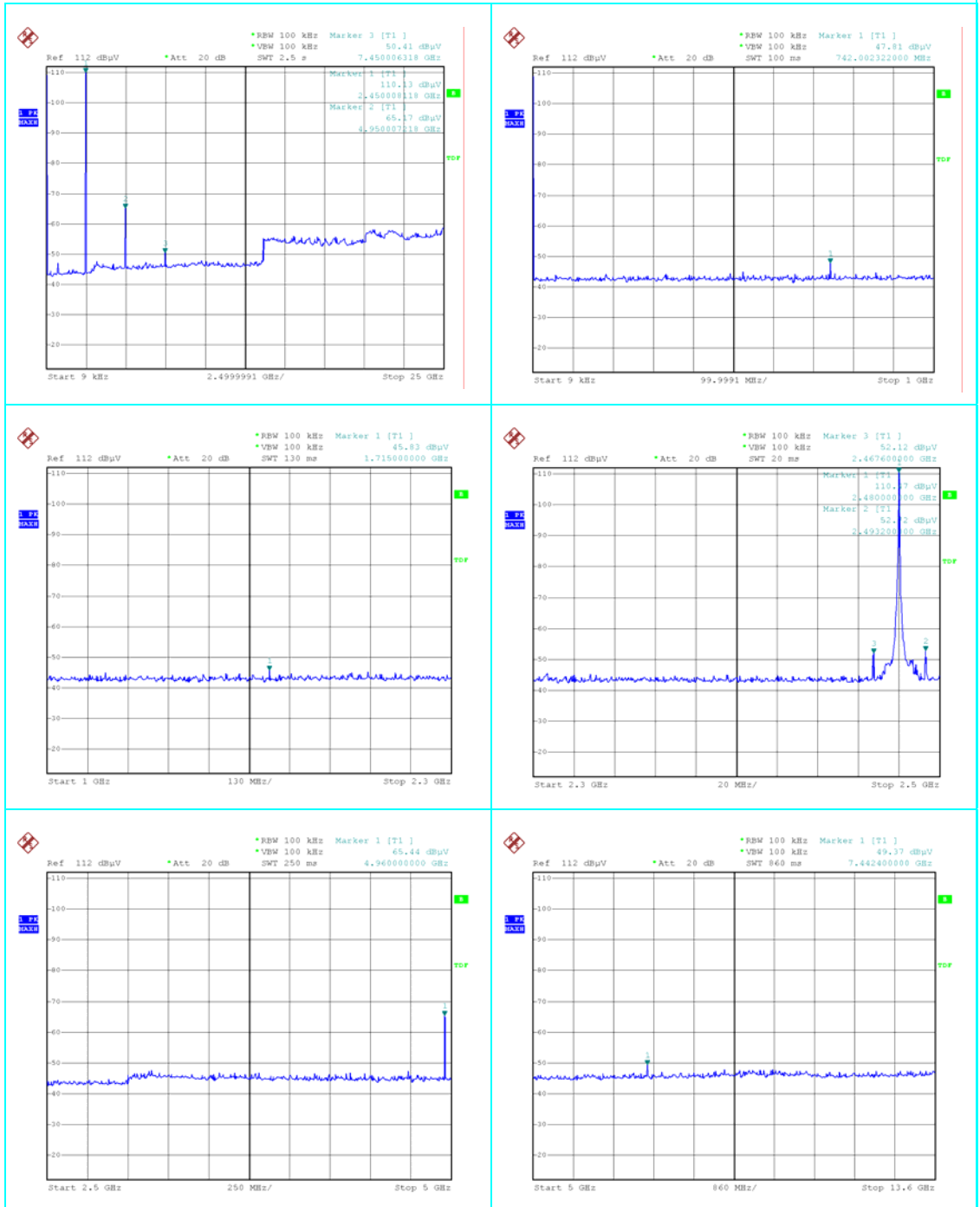

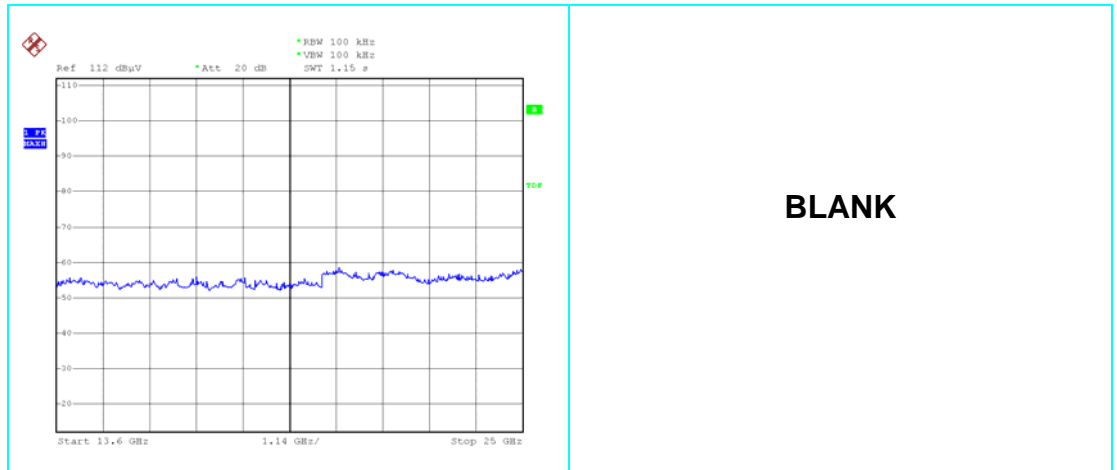

Channel n°78: 2480,00 MHz

**PEAK RESULT**

Frequency (MHz)	Measured spurious (dBμV)	Limit (dBμV)	Margin (dB)
742,00	47,81	90,47	42,66
1715,00	45,83	90,47	44,64
2467,60	52,12	90,47	38,35
2480 (fundamental)	110,47	-----	-----
2493,20	52,72	90,47	37,75
4960,00	65,44	90,47	25,03
7442,40	49,37	90,47	41,10

TEST No.11	Title	47CFR Part 15 Ref. Section
		“ Transmitter Power Spectral Density”
TEST SET-UP & REQUIREMENTS	Spectrum analyzer settings	
	Span	300 kHz
	Resolution (or IF) Bandwidth (RBW)	3 kHz
	Video (or Average) Bandwidth (VBW)	10 kHz
	Sweep time	100 s
	Detector function	Peak
	Trace	max hold
	Attenuator	/
	LIMIT	8 dBm

The transmitter output was connected to the spectrum analyzer through a test fixture (radio frequency coupling device associated with the dedicated antenna of the equipment under test)

After trace stabilisation the marker shall be set on the signal peak. The indicated level is the power spectral density.

**Test Result:**

Channel (No.)	Power spectral density (dBm)	Plot (No.)
00	-7,40	1
48	-7,37	2
78	-7,38	3

**Plot No. 1:**

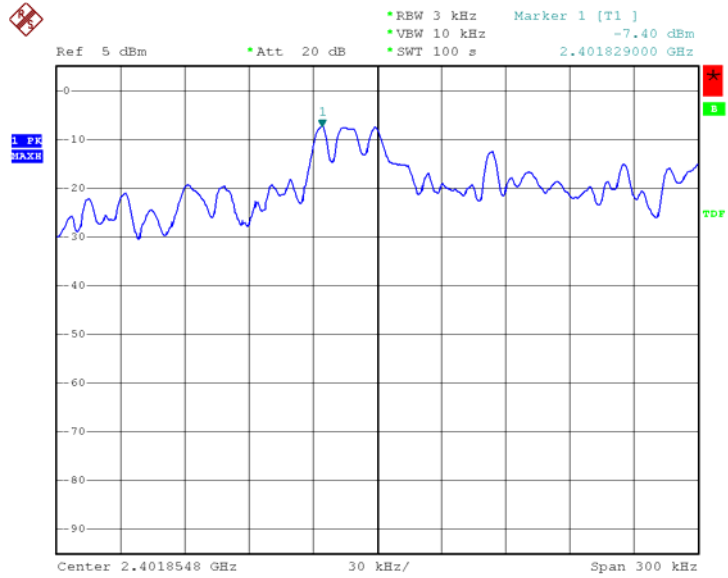

**Plot No. 2:**

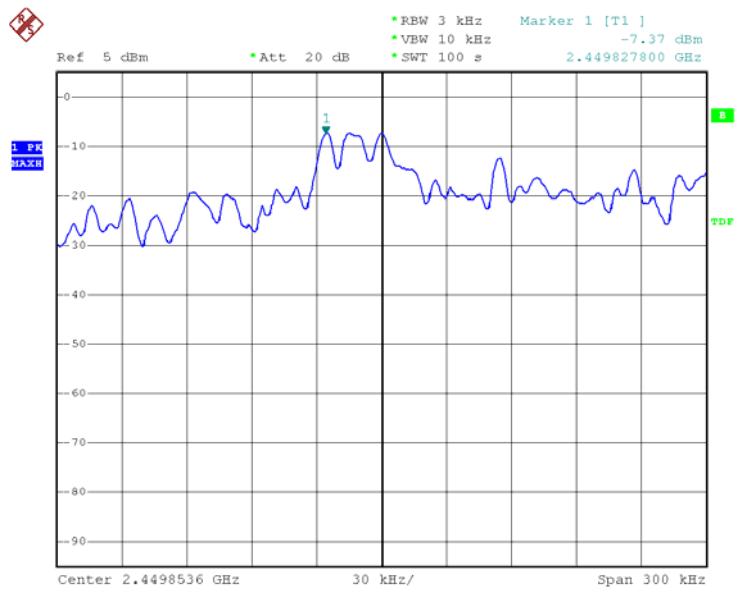

**Plot No. 3:**

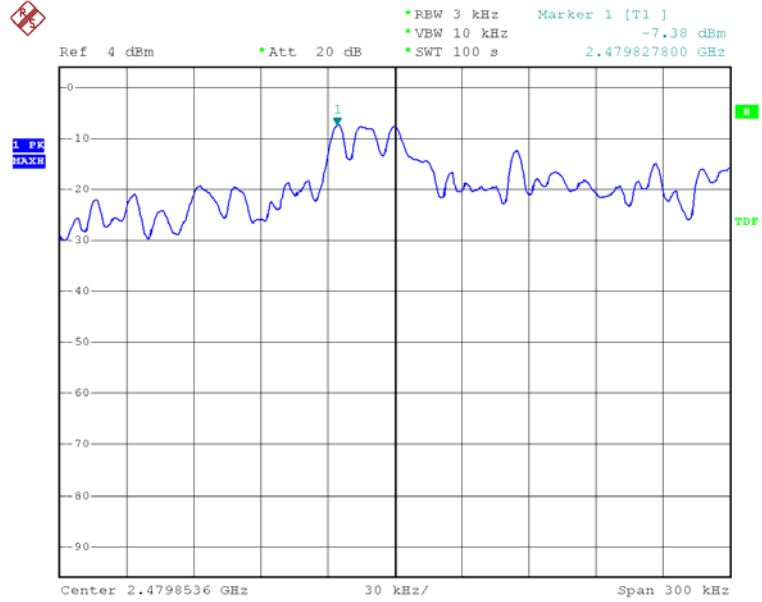

TEST No. 12	Title "RF Exposure Evaluation"		47CFR Part 15 Ref. Section
			<b>15.247 (i)</b>
<b>TEST SET-UP &amp; REQUIREMENTS</b>	Systems operating under the provisions of this section shall be operated in a manner that ensures that the public is not exposed to radio frequency energy levels in excess of the Commission's guidelines. See § 1.1307(b)(1) of this Chapter.		
	EUT classification (fixed, mobile or portable devices)		Fixed, mobile or portable
	LIMITS		See table below

**Limit for maximum permissible Exposure (MPE)**

Frequency Range (MHz)	Electric Field Strength (E) (V/m)	Magnetic Field Strength (H) (A/m)	Power Density (S) (mW/cm <sup>2</sup> )	Average Time (minutes)
<b>(A) Limits for Occupational/Controlled Exposure</b>				
0.3÷3.0	614	1.63	(100)*	6
3.0÷30	1842/f	4.89/f	(900/f <sup>2</sup> )*	6
30÷300	61.4	0.163	1.0	6
300÷1500	--	--	f/300	6
1500÷100,000	--	--	5	6
<b>(B) Limits for General Population/Uncontrolled Exposure</b>				
0.3÷3.0	614	1.63	(100)*	30
3.0÷30	824/f	2.19/f	(180/f <sup>2</sup> )*	30
30÷300	27.5	0.073	0.2	30
300÷1500	--	--	f/1500	30
1500÷100,000	--	--	1.0	30
F = Frequency in MHz      *Plane-wave equivalent power density				

The distance from the device's transmitting antenna where the exposure level reaches the maximum permitted limit is calculated using the general equation:

$$S = P \cdot G / 4\pi R^2$$

Where:

S = Power Density (mW/cm<sup>2</sup>)

P = Conducted power (mW)

G = Linear power gain relative to isotropic radiator (numeric gain)

R = Distance (cm)

**RF Exposure evaluation Distance:**

Channel (No.)	Frequency (MHz)	Output power to antenna (dBm)	Power density @ 20 cm (mW/cm <sup>2</sup> )	Distance where the exposure level reaches the limit (cm)	Limits (mW/cm <sup>2</sup> )
00	2402,00	3,67	0,001	0,483	1
38	2440,00	3,63	0,001	0,481	1
78	2480,00	3,48	0,001	0,473	1

**Test Result:**

The EUT operates at low power level so it does not exceed the Commission's RF exposure guidelines limits; furthermore, Spread spectrum transmitters operate according to the Section 15.247 are categorically excluded from routine environmental evaluation.

RF exposure limit warning or SAR test are not required.



## 6 ADDITIONAL TECHNICAL INFORMATION

### 6.1 ELECTROMAGNETICALLY RELEVANT COMPONENTS:

Components	N°	Manufacturer	Type – Technical data
<b>Radio Module</b>			
See Technical document			
<b>Host Equipment</b>			
-----		----	----

### 6.2 RFI SUPPRESSION DEVICES:

Components	N°	Manufacturer	Type – Technical data
None			

### 6.3 EMI PROTECTION DEVICES:

Components	N°	Manufacturer	Type – Technical data
None			

## 7 TECHNICAL DOCUMENTATION

DOCUMENT	REFERENCE
Bill of materials	7913766D D.PC787-01.V01
Electronic diagram	7913761A E-PC787-01.V03
Radio Layout	7913764A

## 8 PHOTOGRAPHIC DOCUMENTATION

### 8.1 EUT IDENTIFICATION

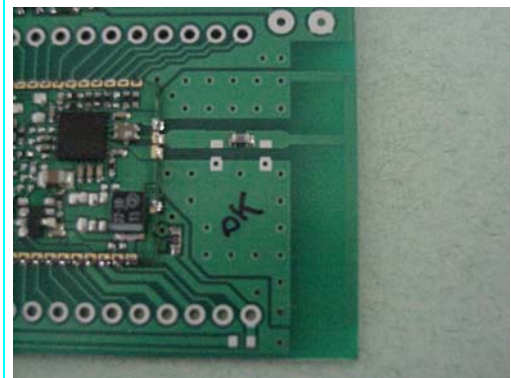
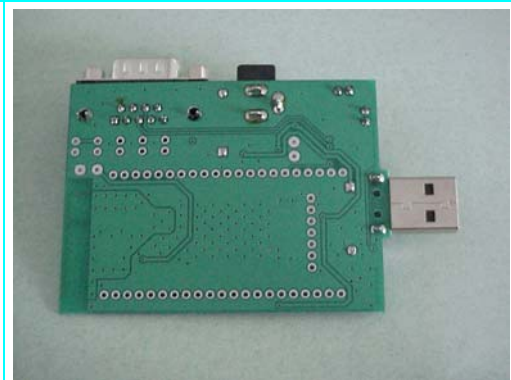

Equipment under test identification: Test jig + Radio module

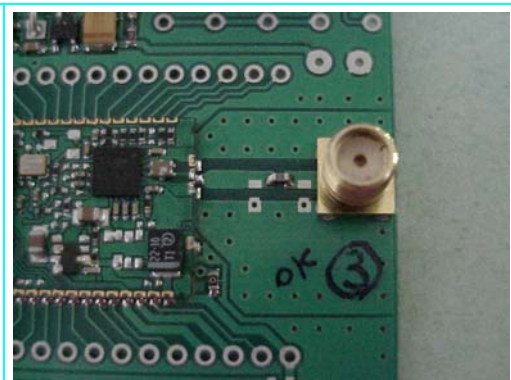
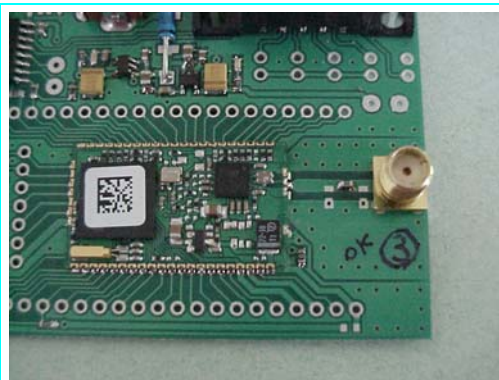

Radio module + antenna connector (for conducted spurious test)

## 8.2 TEST SET-UP

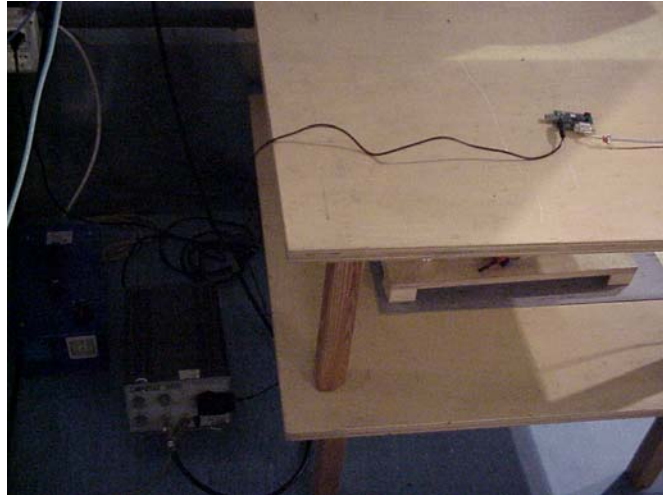

Set up of Conduced emission test

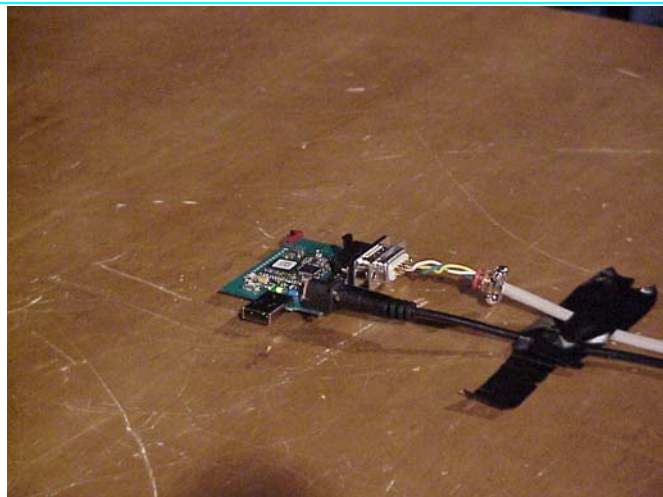

Set up of Radiated emission test

## 9 MEASUREMENT AND TEST EQUIPMENT INSTRUMENTATION

INSTRUMENTS	MANUFACTURER	MODEL	IMQ SERIAL NUMBER	Ref. TEST
Emi Receiver	Rohde & Schwarz	ESHS10	S-03494	2
Artificial Mains V-network	COMTEST	/	S-02405	2
Software for test automation	Rohde & Schwarz	ES-K1 V.1.60	-	2
Spectrum Analyzer	Rohde & Schwarz	FSP40	S-03629	3÷11
Antenna BilogP	ARA	LPD-2513	S-02385	3
Antenna ridged horn 1÷18 GHz	Schwarzbeck	BBHA9120D	S-03464	3 and 8
Antenna ridged horn 15÷40 GHz	Schwarzbeck	BBHA9170	S-03668	3
Pre-amplifier	HP	HP 8449 B	S03542	3
Band Reject Filter 2400÷2483 MHz	Wainwright	WRCG2400/2483	S-04308	3
Highpass Filter 3.4÷18 GHz	Wainwright	WHK3.4/18	S-04309	3 and 10