

Getting started with SensorTile.box PRO multi-sensors and wireless connectivity development kit for any intelligent IoT node

Introduction

The **STEVAL-MKBOXPRO** (SensorTile.box PRO) is the new ready-to-use programmable wireless box kit for developing any IoT application based on remote data gathering and evaluation. It exploits the full kit potential by leveraging both motion and environmental data sensing, along with a digital microphone, and enhances connectivity and smartness in all environments.

The hardware node is a board that fits into the palm of your hand (40x63 mm) with a long-life 3.7 V 480 mAh rechargeable battery. The user can connect to the board via Bluetooth® by using the **ST BLE Sensor Classic** app (available both on Google Play and the Apple Store) on their smartphone and immediately build their own apps through a special interface. Apps can be developed quickly regardless of the level of expertise:

- **Entry mode:** play around with the default apps and see what STMicroelectronics sensors can achieve
- **Expert mode:** create your own app in a simple graphic environment
- **Pro mode:** develop code in an intuitive way using the STM32 open development environment (ODE) and STMicroelectronics function pack libraries

The kit board includes an ultra-low power programmable Bluetooth® Low Energy wireless SoC solution BlueNRG-LP 355AC, that is compliant with Bluetooth(R) Low Energy v5.2. This transmitter module is FCC (FCC ID: S9N-MKBOXPRO) certified and IC (IC: 8976C-MKBOXPRO; PMN: STEVAL-MKBOXPRO; HVIN: STEVAL-MKBOXPRO; FVIN: STSW-MKBOXPRO-BL) certified. The board also includes a wireless charger and a programmable NFC tag.

In addition, a DIL24 socket for easy MEMS adapter connection and a microSD™ card for storing data are available.

Figure 1. STEVAL-MKBOXPRO (SensorTile.box PRO) multi-sensor and wireless connectivity development kit



1 Getting started

1.1 Precaution for use

Warning: Charge the device with a DC 5 V–500 mA USB charger at a temperature from 10 °C to 35 °C.

The kit must be used within the working temperature range. It must never be exposed to excessive heat such as direct sunlight, fire, or heating equipment.

Danger: Use only USB chargers equipped with short-circuit protections to prevent fire hazard.

Danger: Use only wireless chargers with foreign object detection (FOD) to prevent high temperatures.

Danger: Use only the LiPo battery provided with the kit (HiMax 752535). Replacing the battery with an incorrect type can void any safeguards.

LiPo batteries can be damaged and even explode if they are short-circuited, overcharged, or through improper usage, such as mechanical crushes, hot oven, or battery cutting.

Table 1. Precautions for use

Parameter	Range
Operating temperature	10°C to 35°C
Charging temperature	10°C to 35°C
Humidity	Up to 80%
Operating altitude	Up to 2000 m

1.2 Features

- Ultra-low-power with FPU Arm-Cortex-M33 with a TrustZone® microcontroller (STM32U585AI)
- High precision sensors to gather high-quality data:
 - Low-voltage local digital temperature sensor (STTS22H)
 - 6-axis inertial measurement unit (LSM6DSV16X)
 - 3-axis low-power accelerometer (LIS2DU12)
 - 3-axis magnetometer (LIS2MDL)
 - Pressure sensor (LPS22DF)
 - Digital microphone/audio sensor (MP23DB01HP)
- User interface:
 - Hardware power switch
 - Green and orange system LED to display the power supply state
 - Four programmable status LEDs (green, red, orange, blue)
 - Two programmable push-buttons
 - Audio buzzer
 - Reset button
 - Qvar with electrodes for user interface experience
 - Interface for J-Link/SWD debug-probe
 - Interface for extension board
 - Socket for DIL24 sensor adapters

- Connectivity:
 - microSD™ card slot
 - Bluetooth® Low Energy 5.2 (BlueNRG 355AC)
 - NFC tag (ST25DV04K)
- Power and charging options:
 - USB Type-C® charging and connecting
 - 5 W wireless charging
 - 480 mAh battery

1.3 RF specifications

- RF output power for Bluetooth® Low Energy: 0 dBm
 - Bluetooth® Low Energy frequency range: 2402 - 2480 MHz
 - Bluetooth(r) Low Energy Channel spacing: 2 MHz
 - NFC frequency: 13.56 MHz
 - SMD ferrite coil inductor antenna for passive NFC

1.4 Kit components

The STEVAL-MKBOXPRO development kit includes:

- the SensorTile.Box Pro (main board)
- a plastic case with M2.5 screws
- a 480 mAh 3.7 V LiPo battery
- Qvar electrodes
- wireless charger receiver circuit
- programmable NFC tag
- microSD™ card
- STEVAL-MKIGIBV4 STLINK adapter with programming cable.

Figure 2. STEVAL-MKBOXPRO components



Figure 4. Layout of the core system board components - bottom

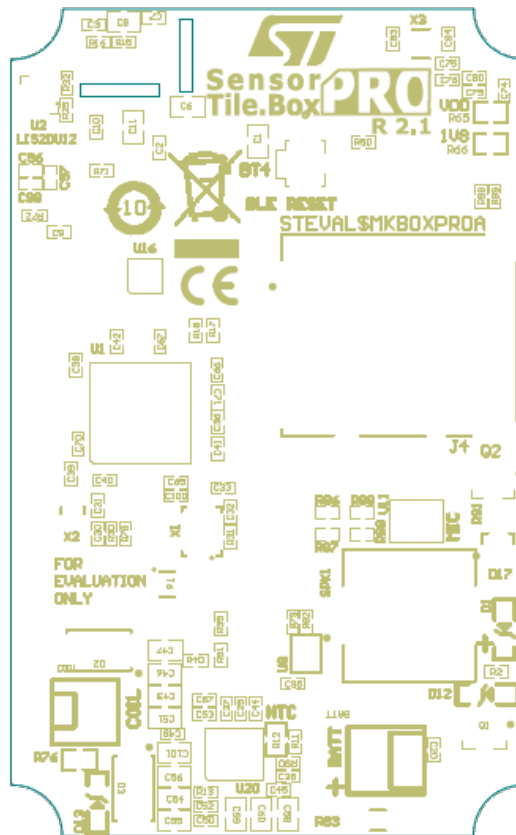

1.6 Core system board

Figure 5. STEVAL-MKBOXPRO block diagram

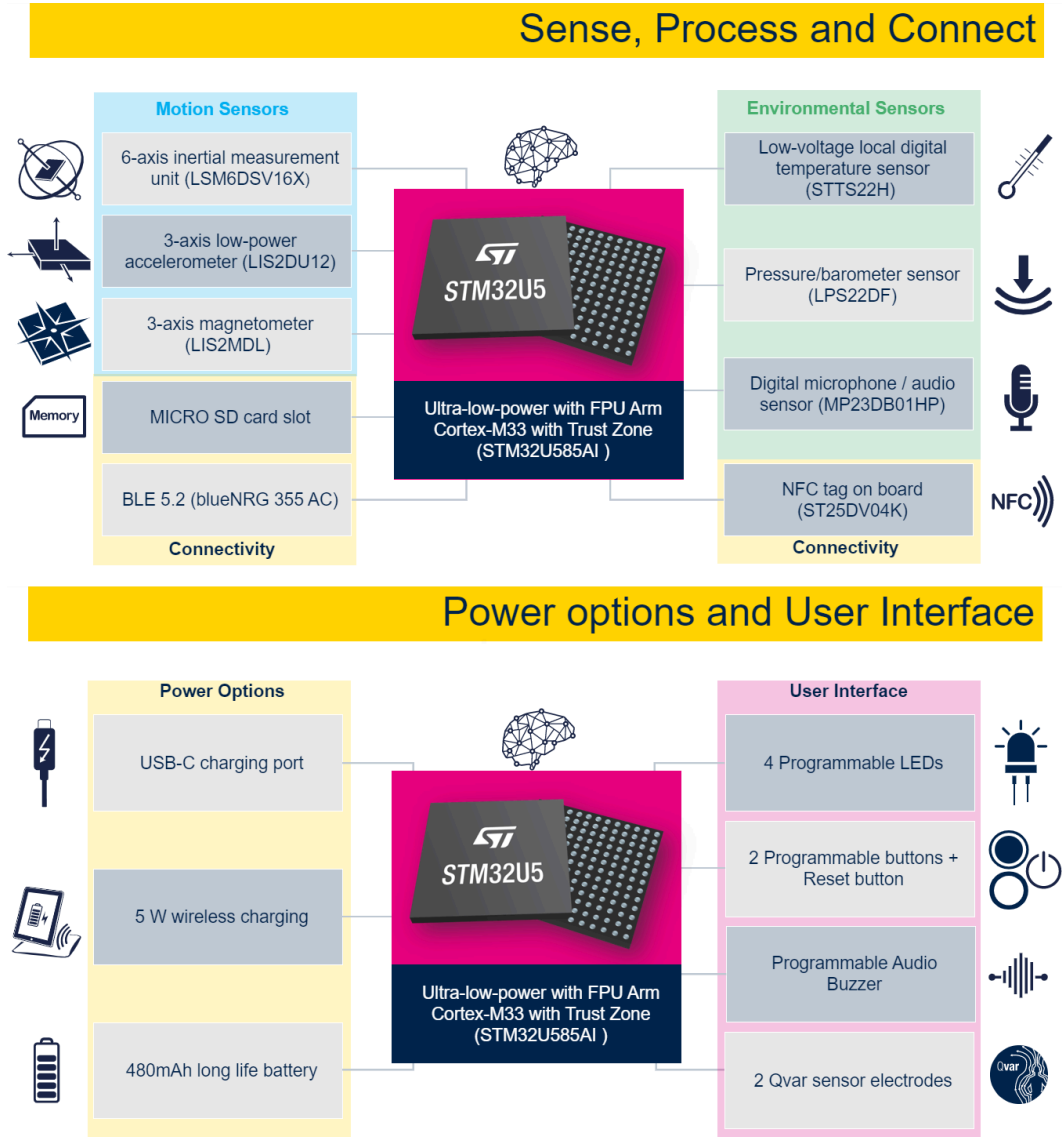

Figure 6. STEVAL-MKBOXPRO evaluation kit - top view

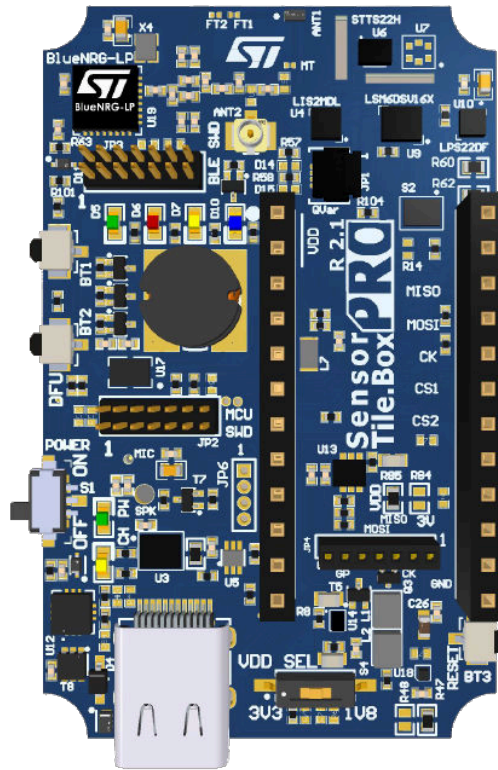
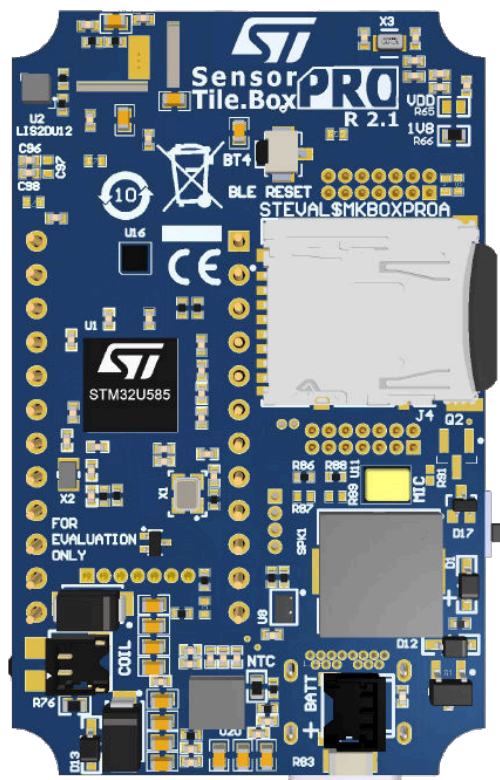

Figure 7. STEVAL-MKBOXPRO evaluation kit - bottom view



1.7 Functional blocks

1.7.1 Sensing

The core system board offers a wide range of sensors specifically designed to support personal electronics applications and to satisfy the demanding requirements of the consumer market.

Figure 8. STEVAL-MKBOXPRO - overview of the sensing components

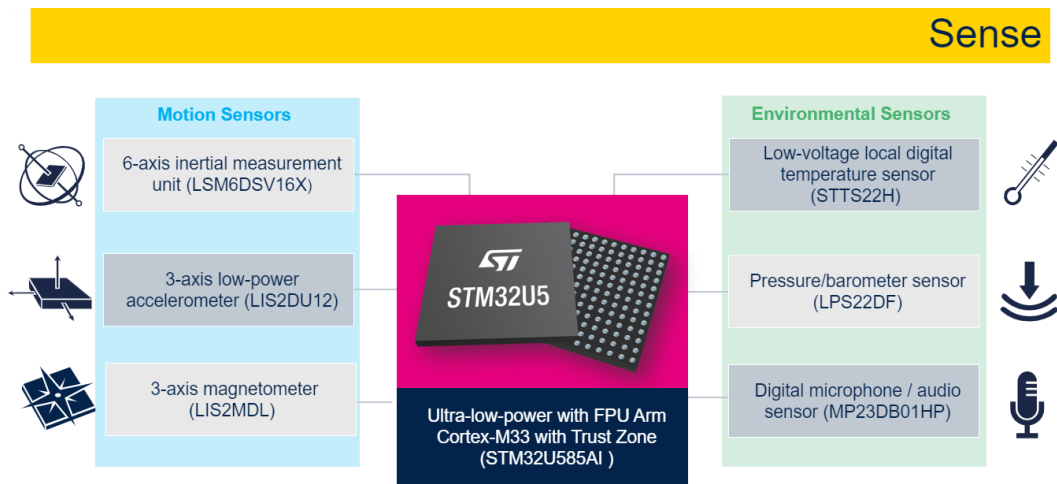

The motion and environmental sensors communicate with the STM32U585AI microcontroller via SPI and/or I²C in order to accommodate the data rates. The signal from the digital microphone is directly managed by the audio digital filter (ADF) interface of the MCU.

Figure 9. STEVAL-MKBOXPRO - sensors on the top side

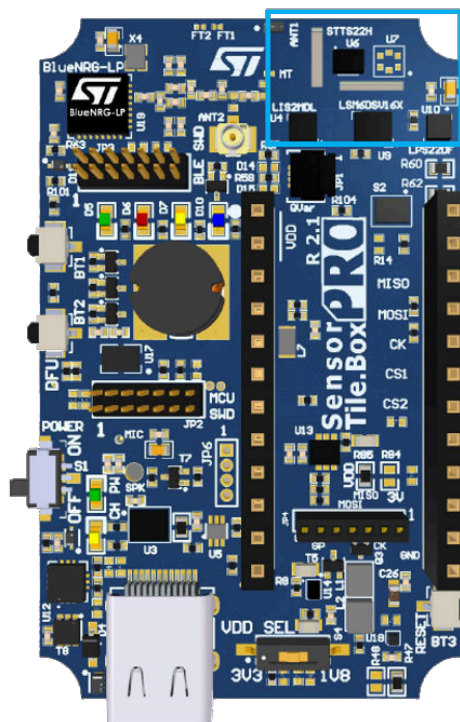
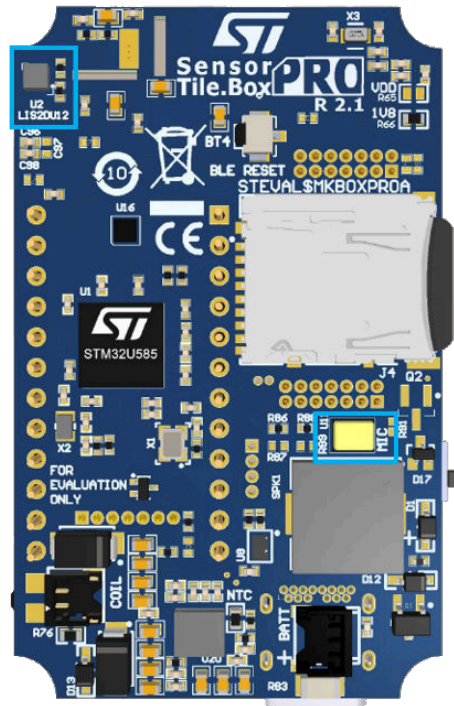

Figure 10. STEVAL-MKBOXPRO - sensors on the bottom side



- U10: LPS22DF MEMS pressure sensor
- U6: STTS22H digital temperature sensor
- U9: LSM6DSV16X IMU, 3D accelerometer and 3D gyroscope with machine learning core, finite State Machine and Qvar
- U2: LIS2SU12 ultra-low-power 3-axis accelerometer for consumer applications
- U4: LIS2MDL 3-axis magnetometer
- U11: MP23DB01HP digital MEMS microphone.

1.7.1.1 LPS22DF

The LPS22DF low-power high-precision ambient pressure sensor. It features from 260 hPa to 1260 hPa absolute pressure range, absolute pressure accuracy of 0.5 hPa, relative accuracy of 0.015 hPa, current consumption down to 1.7 μ A at 1 Hz, and an output data rate from 1 Hz to 200 Hz. It also features an embedded FIFO and interrupt generation logic. The embedded temperature sensor is in the range of -40 °C to +85 °C, with an absolute accuracy of 1.5 °C.

Table 2. LPS22DF I/O configuration

I/O	Configuration
PB6	I2C1_SCL
PB7	I2C1_SDA

1.7.1.2 STTS22H

The STTS22H is an ultra-low-power, high-accuracy, digital temperature sensor. It offers a high performance over the entire operating temperature range.

The STTS22H is coupled with an ASIC featuring A/D converter, signal processing logic, and an I²C/SMBus 3.0 interface.

The sensor is housed in a small 2 x 2 x 0.50 mm 6-lead UDFN package, with the exposed pad down, for a better temperature match with the surrounding environment.

The STTS22H is factory-calibrated and requires no additional calibration.

The STTS22H units are 100% tested on a production setup that is NIST traceable and verified with equipment calibrated in accordance with the IATF 16949:2016 standard.

Table 3. STTS22H I/O configuration

I/O	Configuration
PB6	I2C1_SCL
PB7	I2C1_SDA
PB15	TEMP_INT

1.7.1.3 LSM6DSV16X

The LSM6DSV16X accelerometer and the gyroscope with triple processing chain; 2, 4, 8, 16 g accelerometer full-scale, 16 g for the secondary channel; 125, 250, 500, 1000, 2000, 4000 dps gyroscope full-scale. The output data rate is from 1.875 Hz to 7.68 kHz.

It features an enhanced machine learning core (MLC) and finite state machine (FSM). The FSM core can also reconfigure the sensor.

Table 4. LSM6DSV16X I/O configuration

I/O	Configuration
PI2	SPI2_MISO
PI3	SPI2_MOSI
PI1	SPI2_CLK
PI5	SPI_sen_CS_G
PB6	I2C1_SCL
PB7	I2C1_SDA
PA4	IMU_INT1
PD11	IMU_INT2

1.7.1.4 LIS2DU12

The LIS2DU12 is a linear 3-axis accelerometer with advanced digital functions. The MEMS and ASIC have been expressly designed to build an outstanding ultra-low-power architecture, in which the anti-aliasing filter operates with some of the lowest current consumption on the market.

The LIS2DU12 has user-selectable full-scales of $\pm 2g/\pm 4g/\pm 8g/\pm 16g$, and is capable of measuring accelerations with output data rates from 1.6 Hz to 800 Hz. The LIS2DU12 has an integrated 128-level FIFO buffer, allowing to store a wide range of data, reducing system power consumption.

The embedded self-test capability allows the user to check that the sensor works in the final application. The LIS2DU12 has a dedicated internal engine to process motion and acceleration detection including free-fall, wake-up, single/double-tap recognition, activity/inactivity, and 6D/4D orientation.

The LIS2DU12 is available in a small 2.0 x 2.0 mm plastic land grid array package (LGA) only 0.74 mm thin, which places it among the smallest solutions available on the market. It is guaranteed to operate over an extended temperature range from -40 °C to + 85 °C.

Table 5. LIS2DU12 I/O configuration

I/O	Configuration
PI2	SPI2_MISO
PI3	SPI2_MOSI
PI1	SPI2_CLK
PI7	SPI_sen_CS_A
PB6	I2C1_SCL
PB7	I2C1_SDA
PF2	ACC_INT1
PF15	ACC_INT2

1.7.1.5
LIS2MDL

The LIS2MDL is a high-accuracy, ultra-low-power, 3-axis digital magnetometer. It features a magnetic field dynamic range up to ± 50 gauss.

The LIS2MDL includes an I²C serial bus interface, which supports standard, fast mode, fast mode plus, high-speed (100 kHz, 400 kHz, 1 MHz, and 3.4 MHz), and an SPI serial standard interface.

The device can be configured to generate an interrupt signal for magnetic field detection.

The LIS2MDL is available in a plastic land grid array package (LGA) and is guaranteed to operate over an extended temperature range from -40 °C to $+85$ °C.

Table 6. LIS2MDL I/O configuration

I/O	Configuration
PB6	I2C1_SCL
PB7	I2C1_SDA
PE6	MAG_DRDY

1.7.1.6
MP23DB01HP

The MP23DB01HP is an ultra-compact, low-power, omnidirectional, digital MEMS microphone, built with a capacitive sensing element and an IC interface with optional stereo configuration.

The sensing element, capable of detecting acoustic waves, is manufactured using a specialized silicon micromachining process dedicated to producing audio sensors. The IC interface is manufactured using a CMOS process that allows designing a dedicated circuit able to provide a digital signal externally in PDM format.

The MP23DB01HP offers multiple performance modes (power-down, low-power, and performance mode) enabled by different clock frequency ranges. The device has a very high AOP in performance mode, sensitivity range of ± 1 dB and high SNR for all operative modes. The MP23DB01HP is available in a bottom-port, SMD-compliant, EMI-shielded package and is guaranteed to operate over an extended temperature range from -40 °C to $+85$ °C.

Table 7. MP23DB01HP I/O configuration

I/O	Configuration
PE9	MIC_ADF_CK
PE10	MIC_ADF_SD
GND	L/R

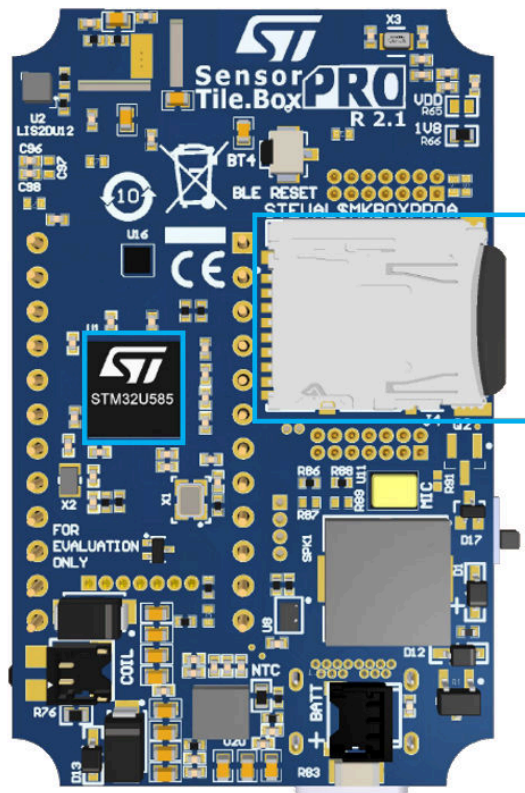
Figure 13. MCU and connectivity components (bottom view)

- U1: STM32U585AI ultra-low-power Arm Cortex®-M33 with FPU and TrustZone® at 160 MHz
- U19: BlueNRG-LP Bluetooth® Low Energy v5.2 wireless technology SoC
- U17: NFC tag
- L3: NFC coil
- J4: microSD™ card socket

1.7.2.1 **STM32U585AI**

The STM32U585xx device belongs to an ultra-low-power microcontroller family (STM32U5 series) based on the high-performance Arm Cortex®-M33 32-bit RISC core. They operate at a frequency of up to 160 MHz.

The Arm Cortex®-M33 core features a single-precision FPU (floating-point unit), which supports all the Arm single-precision data-processing instructions and all the data types. It also implements a full set of digital signal processing (DSP) instructions and a memory protection unit (MPU) that enhances the application security.

The device embeds high-speed memories (2 Mbytes of flash memory and 786 Kbytes of SRAM), a flexible external memory controller (FSMC) for static memories (for devices with packages of 90 pins and more), two OCTOSPI flash memory interfaces (at least one quad-SPI available on all packages), an extensive range of enhanced I/Os and peripherals connected to three APB buses, three AHB buses, and a 32-bit multi-AHB bus matrix.

The device offers security foundation compliant with the trusted-based security architecture (TBSA) requirements from Arm. It embeds the necessary features to implement a secure boot, secure data storage, and secure firmware update.

The device also incorporates a secure firmware installation feature that allows the customer to secure the provisioning of the code during its production.

A flexible lifecycle is managed thanks to multiple levels of readout protection and debug unlock with password.

Firmware hardware isolation is supported thanks to securable peripherals, memories and I/Os, and privilege configuration of peripherals and memories.

The device features several protection mechanisms for embedded flash memory and SRAM: readout protection, write protection, secure, and hide protection areas. They also embed several peripherals reinforcing security: a fast AES coprocessor, a secure AES coprocessor with DPA resistance, and a hardware unique key that can be shared by hardware with fast AES, a public key accelerator (PKA) with DPA resistance, an on-the-fly decryption engine for OCTOSPI external memories, a HASH hardware accelerator, and a true random number generator.

The device also features active tamper detection and protection against transient and environmental perturbation attacks, thanks to several internal monitors generating secret data erase in case of attack. This helps to fit the PCI requirements for point of sales applications.

The device offers one fast 14-bit ADC (2.5 Msps), one 12-bit ADC (2.5 Msps), two comparators, two operational amplifiers, two DAC channels, an internal voltage reference buffer, a low-power RTC, four 32-bit general-purpose timers, two 16-bit PWM timers dedicated to motor control, three 16-bit general-purpose timers, two 16-bit basic timers, and four 16-bit low-power timers. The device supports a multifunction digital filter (MDF) with six filters dedicated to the connection of external sigma-delta modulators. Another low-power digital filter dedicated to audio signals is embedded (ADF), with one filter supporting sound-activity detection.

The device embeds a Chrom-ART Accelerator dedicated to graphic applications, and mathematical accelerators (a trigonometric functions accelerator plus a filter mathematical accelerator). In addition, up to 24 capacitive sensing channels are available.

The device also features standard and advanced communication interfaces such as: four I2Cs, three SPIs, three USARTs, two UARTs, one low-power UART, two SAIs, one digital camera interface (DCMI), two SDMMCs, one FDCAN, one USB OTG full-speed, one USB Type-C® /USB Power Delivery controller, and one generic synchronous 8-/16-bit PSSI (parallel data input/output slave interface). The device operates in the -40 °C to +85 °C (+105 °C junction) and -40 °C to +125 °C (+130 °C junction) temperature ranges from a 1.71 V to 3.6 V power supply.

A comprehensive set of power-saving modes allows the design of low-power applications. Many peripherals (including communication, analog, timers, and audio peripherals) can be functional and autonomous down to stop mode with direct memory access, thanks to low-power background autonomous mode (LPBAM).

Some independent power supplies are supported, like an analog independent supply input for ADC, DACs, OPAMPs and comparators, a 3.3 V dedicated supply input for USB and up to 14 I/Os, that can be supplied independently down to 1.08 V. A VBAT input is available for connecting a backup battery in order to preserve the RTC functionality and to back up 32-bit registers and 2-Kbyte SRAM. The devices offer eight packages from 48 to 169 pins.

1.7.2.2 **BlueNRG-LP**

The **BlueNRG-LP** is an ultra-low-power programmable Bluetooth® Low Energy wireless SoC solution. It embeds STMicroelectronics' state-of-art 2.4 GHz RF radio IPs combining unparalleled performance with extremely long battery lifetime. It is compliant with Bluetooth® Low Energy SIG core specification version 5.2, addressing point-to-point connectivity and Bluetooth™ mesh networking, and allows large-scale device networks to be established in a reliable way. The BlueNRG-LP is also suitable for 2.4 GHz proprietary radio wireless communication to address ultra-low latency applications. The BlueNRG-LP embeds a Cortex®-M0+ microcontroller that can operate up to 64 MHz and also the BlueNRG core coprocessor (DMA based) for Bluetooth® Low Energy timing critical operations. The main Bluetooth® Low Energy 5.2 specification supported features are: 2 Mbps data rate, long range (coded PHY), advertising extensions, channel selection algorithm #2, GATT caching, hardware support for simultaneous connection, master/slave and multiple roles simultaneously, and extended packet length support. In addition, the BlueNRG-LP provides enhanced security hardware support by dedicated hardware functions: True random number generator (RNG), encryption AES maximum 128-bit security coprocessor, public key accelerator (PKA), CRC calculation unit, 64-bit unique ID, and flash memory read and write protection. The BlueNRG-LP can be configured to support standalone or network processor applications. In the first configuration, the BlueNRG-LP operates as a single device in the application for managing both the application code and the Bluetooth® Low Energy stack. The BlueNRG-LP embeds high-speed and flexible memory types: Flash memory of 256 Kbytes, RAM memory of 64 Kbytes, one-time-programmable (OTP) memory area of 1 Kbyte, ROM memory of 7 Kbytes. Direct data transfer between memory and peripherals, and from memory-to-memory, is supported by eight DMA channels with a full flexible channel mapping by the DMAMUX peripheral. The BlueNRG-LP embeds a 12-bit ADC, allowing measurements of up to eight external sources and up to three internal sources, including battery monitoring and a temperature sensor. The BlueNRG-LP has a low-power RTC and one advanced 16-bit timer. The BlueNRG-LP features standard and advanced communication interfaces: 1x SPI, 2x SPI/I2S, 1x LPUART, 1x USART supporting ISO 7816 (smartcard mode), IrDA and Modbus mode, 2x I²C supporting SMBus/PMBus, 1x channel PDM. The BlueNRG-LP operates in the temperature range of -40 to +105 °C from a 1.7 V to 3.6 V power supply. A comprehensive set of power-saving modes enables the design of low-power applications. The BlueNRG-LP integrates a high efficiency SMPS step-down converter and an integrated PDR circuitry with a fixed threshold that generates a device reset when the VDD drops under 1.65 V. The BlueNRG-LP comes in different package versions supporting up to: 32 I/Os for the QFN48 package, 20 I/Os for the QFN32 package, 30 I/Os for the WCSP49 package.

1.7.2.3 **NFC tag**

The ST25DV04K is an NFC RFID tag offering 4 Kbit of electrically erasable programmable memory (EEPROM). This device has two interfaces: the first one is an I²C serial link that can be operated from a DC power supply, the second one is an RF link activated when the device acts as a contactless memory powered by the received carrier electromagnetic wave.

In I²C mode, the user memory contains up to 512, 2048, or 8192 bytes, which can be split into four flexible and protectable areas.

In RF mode, following ISO/IEC 15693 or NFC Forum Type 5 recommendations, the user memory contains up to 128, 512, or 2048 blocks of 4 bytes, which can be split into four flexible and protectable areas.

The ST25DV04K device offers a fast transfer mode between the RF and contact worlds, thanks to a 256-byte volatile buffer (also called Mailbox). In addition, the GPO pin provides data about incoming events, like RF field detection, RF activity in progress, or mailbox message availability. An energy harvesting feature is also available when external conditions make it possible.

The active area of the NFC coil is between the buttons and DIL24 socket, where the NFC label is on the top of the case.

1.7.2.4 **MicroSD™ card**

On the bottom side of the **SensorTile.box PRO** core system board is a microSD™ card socket that is accessible even when the board is mounted in the plastic case.

A four-bit wide SDIO port allows accessing the card for the maximum performance.

1.7.3 Power options

The *SensorTile.box PRO* core system board includes a range of power management features that enable very low power consumption in final applications. The main supply is through a lithium-ion polymer battery (3.7 V, 480 mAh) and the integrated battery charger (STBC08) with V_{in} [4.25; 6.5V].

Figure 14. Power management of the *SensorTile.box PRO* core system board

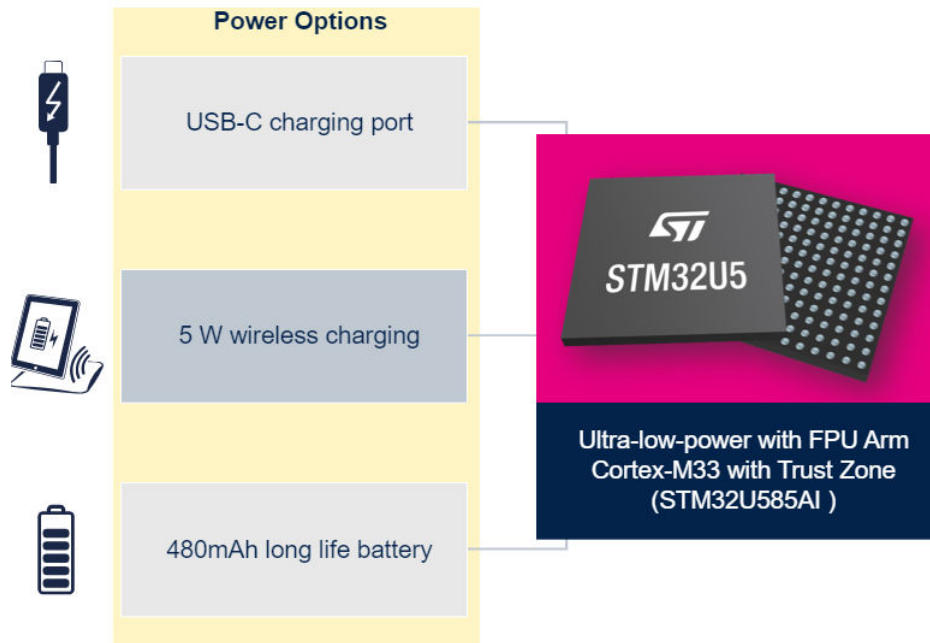

Figure 15. Power components - top view

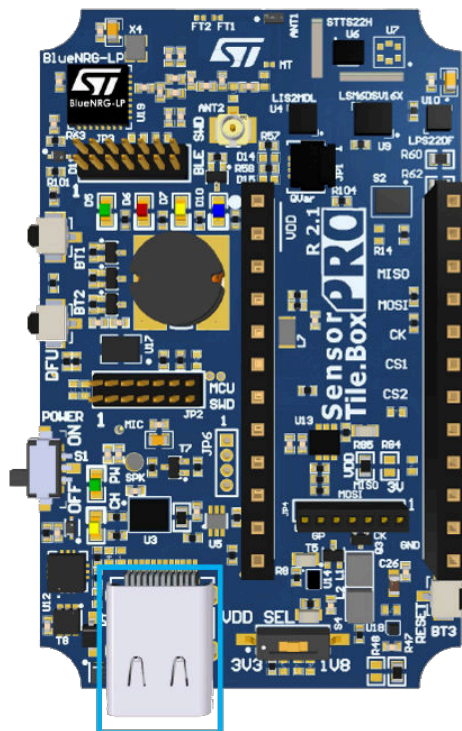
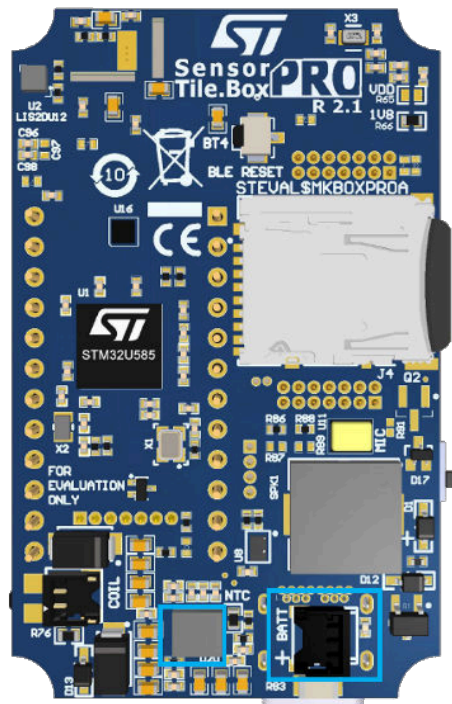

Figure 16. Power components - bottom view



Power management IC

- J_USB_C1: USB3.1 type C
- U20: 5 W wireless charging
- BATTERY: 480 mAh long life battery 3v7
- COIL: connector for wireless charger coil
- VDD SEL: switch for choosing power voltage domain.

1.7.3.1 USB Type-C®

The on-board USB Type-C® connector can be used for both power supply and data transfer (USB device only). You can find several examples of USB class implementation in the STM32 software packages.

1.7.3.2 Wireless charging

The SensorTile Box Pro integrates a wireless power receiver suitable for portable applications and capable of managing up to 5 W of output power. The chip has been designed to support Qi 1.2.4 specifications for inductive communication protocol and base power profile (BPP). It shows excellent efficiency performance thanks to the integrated low-loss synchronous rectifier and the low drop-out linear regulator: both elements are dynamically managed by the digital core, to minimize the overall power dissipation over a wide range of output load conditions. Through the I²C interface, the user can access and modify different configuration parameters, tailoring the operation of the device to the needs of custom applications.

The active area of the wireless charger coil is on the bottom of the case, when the board is in the box.

1.7.3.3 Battery

Connect the long-life 3.7 V 480 mA LiPo battery included in the kit to the dedicated battery connector (BATT) in order to provide the battery supply voltage (VBAT).

1.7.3.4 **Power supply**

Different sources can supply the [SensorTile.box PRO](#) core system board:

- V_USB: through USB Type-C® connector (sink only, 5 V)
- Wireless charger connector (annotation “COIL” on the board)

The STBC08 battery charger automatically charges the battery from the available main source, with the right battery profile.

The equipment is intended to work properly with an operating temperature of 35 °C.

Moreover, two LEDs are used to display the battery state:

- LED D8, green LED turns on when an external power supply source is present (wireless charger or USB)
 - It does not mean that the board is turned on
- LED D9, orange LED turns on when the battery is being charged
 - It turns off when the battery is fully charged or disconnected

There is also a POWER switch to turn on and off the board, and a RESET button connected to the STM32 reset pin (BT3).

1.7.3.5 **Switch for choosing board power voltage domain**

As the label points out, the domain can be switched between 1.8 and 3.3 V.

Both STM32 and BlueNRG-LP automatically follow the selected domain.

1.7.3.6 **Power-on and power-off procedure**

The POWER switch can be used to turn on and off the [SensorTile.boxPRO](#) board. Whether it is turned on or off, both the USB and the wireless charger can be used to charge the battery.

1.8 User interface options

The *SensorTile.box PRO* core system board includes several user interfaces for the user interaction:

- Hardware power switch
- Green and orange system LED to display the battery state
- 4 programmable status LEDs (green, red, orange, blue)
- Programmable push-buttons
- Audio buzzer
- Qvar electrodes for user interface experience
- Interface for J-Link/SWD debug-probe
- Interface for extension board
- Socket for DIL24 sensor adapters

Figure 17. *SensorTile.box PRO* user interface

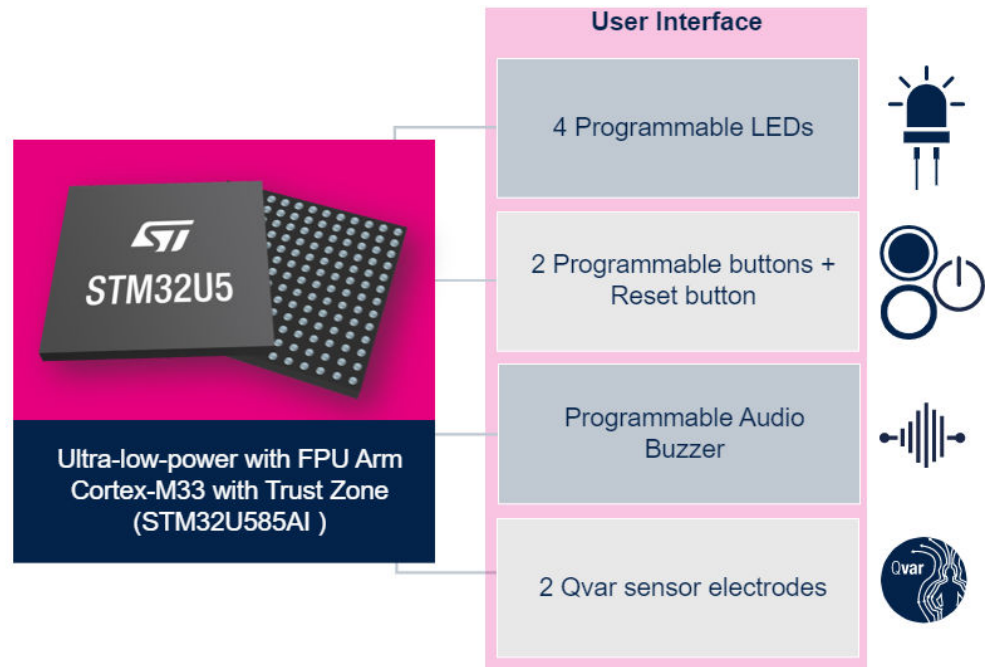
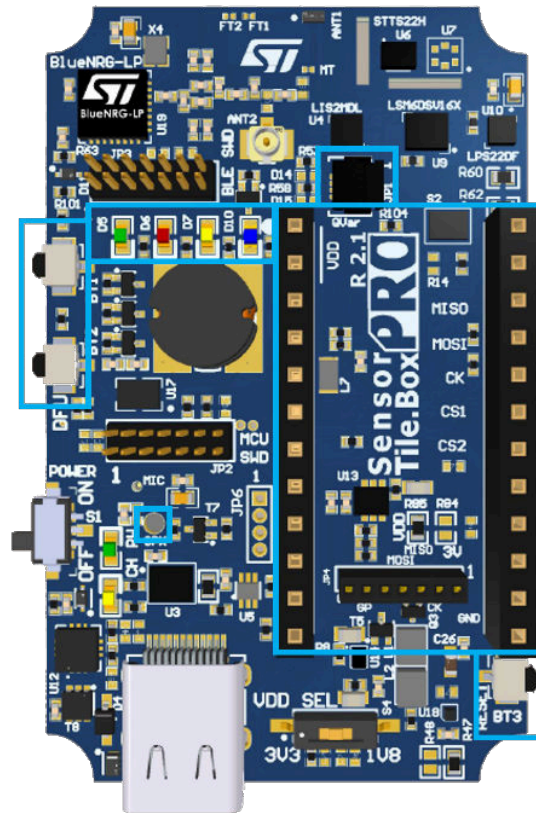

Figure 18. User interface components



User interface:

- D5, D6, D7, D10: four programmable LEDs
- BT1, BT2: two programmable buttons, and a RESET button
- SPK1: audio buzzer
- Qvar sensor electrodes connected to the board through a flex connector JP1
- J1: Socket DIL24
- JP4: extension board connector

1.8.1 Programmable LEDs

The *SensorTile.box PRO* core system board includes four programmable LEDs for user interaction:

- LED D5: green
- LED D6: red
- LED D7: orange
- LED D10: blue

They are all connected to the STM32.

1.8.2 Programmable buttons

The *SensorTile.box PRO* core system board includes two user buttons: BT1 and BT2. They are connected to the STM32.

1.8.3 Buzzer

The *SensorTile.box PRO* core system board includes a piezoelectric sounder, which is connected to the STM32. It can be used to produce frequencies for audio applications.

1.8.4 Qvar

The SensorTile.box PRO core system board includes an embedded Qvar (electric charge variation detection) channel which can be enabled for sensing left/right and right/left swipe, and different tap configurations. Qvar electrodes are accessible outside the case, as shown in the image below.

For further details about Qvar, please refer to AN5755 “Qvar sensing”.

Figure 19. SensorTile.box PRO Qvar electrodes



1.8.5 Socket DIL24

The SensorTile.box PRO core system board includes a socket DIL24 for easy MEMS adapter connection. For further details about DIL24 adapters, please refer to the product selector at the following path: <https://www.st.com/en/evaluation-tools/mems-motion-sensor-eval-boards.html#products>, where STEVAL-MKI adapter boards are considered.

Figure 20. SensorTile.box PRO DIL24 socket

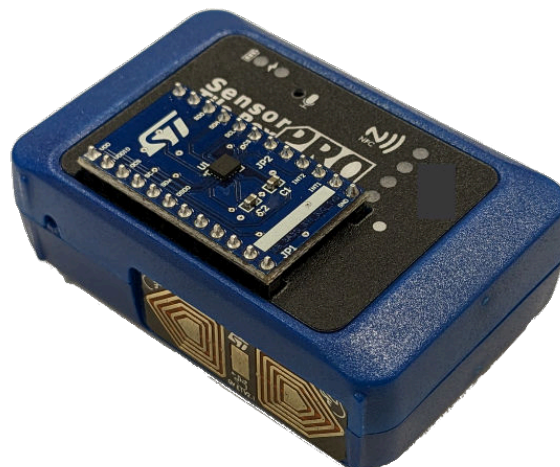

1.8.6 Interface for extension board

It features SPI or I²C communication interface along 2 GPIOs. Power supply can be 1.8 V or 3 V.

2 How to program the board

2.1 Restore to factory settings

To restore the factory settings, the user must download the [STSW-MKBOXPRO-FS](#) binary package. Open this package on your PC and follow the instructions.

Note: If you would restore the DTM of Bluetooth® Low Energy using the *STLINK* programmer following the instruction in [Section 2.3 How to program the SensorTile.box PRO with an external debugger](#), only connecting the programmer cable to the Bluetooth® Low Energy connector (BLE_SWD or JP3).

2.2 How to program the SensorTile.box PRO in “DFU mode” (via USB)

This is the easiest mode if the user wants to download a binary into the board via USB, without the need of any debugging capabilities.

The advantage is that no additional debugger is needed, just a USB Type-C® cable and [STM32CubeProgrammer](#) software installed on the PC.

To enter the “Firmware upgrade” mode, follow the procedure below:

- Step 1.** Turn off the board through power switch S1
- Step 2.** Connect USB Type-C® cable to the board
- Step 3.** To enter DFU mode, turn on the board through power switch S1, while pressing button BT2 and then release the button
- Step 4.** You can upgrade the firmware by following the steps below:
 - Step 4a.** Open [STM32CubeProgrammer](#) software
 - Step 4b.** Select [USB] on the top-right corner
 - Step 4c.** Click on [Connect]
 - Step 4d.** Go to the [Erasing and Programming] tab
 - Step 4e.** Search for the new .bin or .hex binary file to be flashed into the board
 - Step 4f.** Click on [Start Programming]

2.3 How to program the SensorTile.box PRO with an external debugger

The [SensorTile.boxPro](#) programming connector JP2 is natively compatible with the *STLINK-V3* debugger family (*STLINK-V3SET* or *STLINK-V3MINIE*).

Note: *STLINK-V3* programmers are not included in the kit.

To offer more alternatives, an adapter to *STLINK V2-1* (STM32 Nucleo development board) or standard JTAG connector is included in the kit ([STEVAL-MKIGIBV4](#) *STLINK* adapter with programming cable).

When using an STM32 Nucleo development board as an external debugger, the user needs to disconnect the on-board STM32 by removing the two jumpers on CN2 on the Nucleo board.

Once the hardware connections are in place, the user can flash memory with the provided projects with their preferred IDE ([STM32CubeIDE](#), [EWARM](#), or [Keil®](#)).

2.4 Troubleshooting

If the board is seen in the Connect to a device screen as in the screen below (only board name and ID: MAC address) it means that the board has no database entry.

Figure 21. Example of a board shown with no database entry



In this case, the user should follow the following procedure to be able to perform a Fast FOTA update to the latest version of the default firmware (STSW-MKBOXPRO - entry/expert mode).

- Step 1.** From the home screen, click on Create a new application and select the sensrotile.box-PRO. From this screen, select the MORE tab in the bottom right corner of the screen and choose the Custom Fw Db Entry.

Figure 22. MORE tab in ST BLE Sensor Classic app

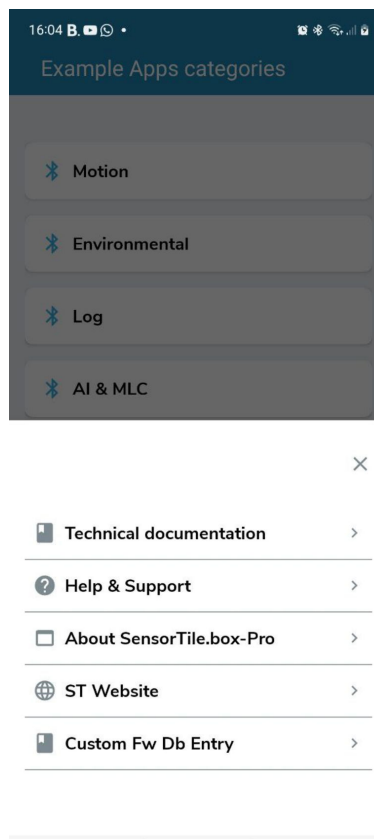

- Step 2.** A screen is opened with a custom Database entry for the sensortile.box-PRO. Here, the user should open the options window by tapping the three dots in the upper right corner, and tap on the download icon (circled in red).

Figure 23. Browser screen example where to download the json file

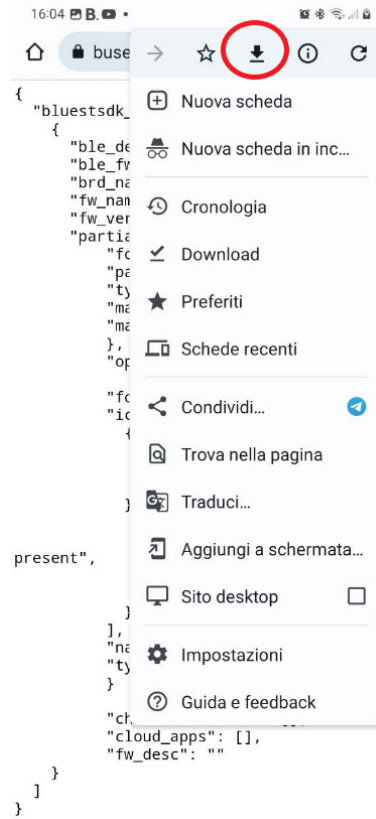

- Step 3.** Go back to the home screen of the **ST BLE Sensor Classic** app and return to the Connect a new device screen. Here, tap on the three dots in the bottom right corner, and select “Add Custom Fw Db Entry”.

Figure 24. Add Custom Fw Db Entry screen

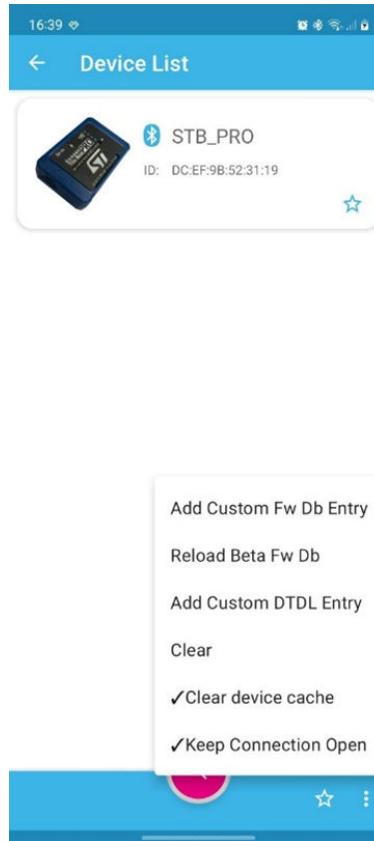

- Step 4.** The file manager of the phone will open, here you can search in the downloads folder of your browser for the file just downloaded, named `DefaultFw_0_9_0.json` and select it. The board should now be seen as in the figure below, with a custom model loaded. Now you can connect to it.

Figure 25. Example of board shown with custom database entry

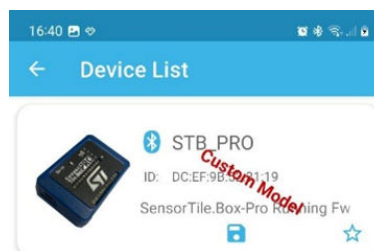

- Step 5.** Open the menu in the upper left corner and go to the Board Configuration screen and select Firmware Download, in the Board Control Section.

- Step 6.** By clicking on the list of compatible firmware (circled in red) the STSW-MKBOXPRO entry/expert mode will be available to choose. Tap on it and then tap on install STSW-MKBOXPRO entry/expert mode.

Figure 26. Firmware Download screen

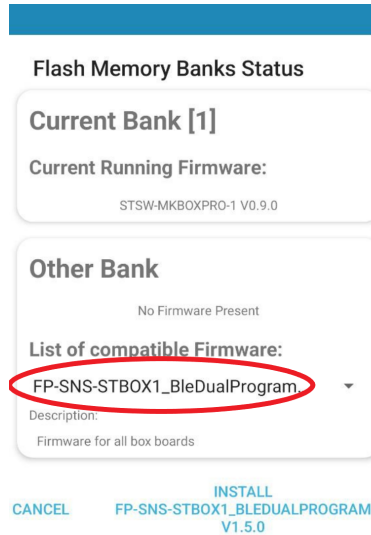

The Fast FOTA procedure will update the board and the new official Database entry will be updated automatically (no need for this procedure on the next updates).

3 Development applications

The [ST BLE Sensor Classic](#) app on your smartphone (both on the Android Play Store and iOS App Store) allows you to immediately connect to the box kit.

The user can appreciate the full SensorTile.box PRO experience regardless of their level of expertise; the box kit could be exploited according to three different modalities:

- **Entry mode:** wide range of default IoT and wearable applications
- **Expert mode:** build custom applications leveraging the available algorithms
- **Pro mode:** develop code in an intuitive way using STM32 open development environment (ODE) and STMicroelectronics function pack libraries.

3.1 Entry mode

The [ST BLE Sensor Classic](#) bundles a wide range of default IoT and wearable applications:

1. Turn on your SensorTile.box PRO by sliding the Power button to 'ON'
2. Open the [ST BLE Sensor Classic](#) app (with Bluetooth® enabled)
 - At the first power-on, navigate the app to "Connect one device", and once paired and connected, start the firmware upgrade with the FOTA function by clicking on the prompt
 - The FOTA function is used whenever a new version of the board firmware is released
3. The user can try the default application by connecting, or click on "Create a new Application" in the app home screen. The user can experiment with all the possibilities, using pre-defined applications or developing their own with a simple interface in "expert mode".

This is a list of the entry mode applications:

- Motion
 - Compass
 - Free-Fall Detection
 - Level
 - Pedometer
 - Sensor fusion - quaternion
- Environmental
 - Barometer
- Log
 - Data recorder
- AI and MLC
 - Human activity recognition
 - Baby Crying Detector
 - In-Vehicle Baby Alarm
- User interface
 - Qtouch
- Connectivity
 - NFC tag

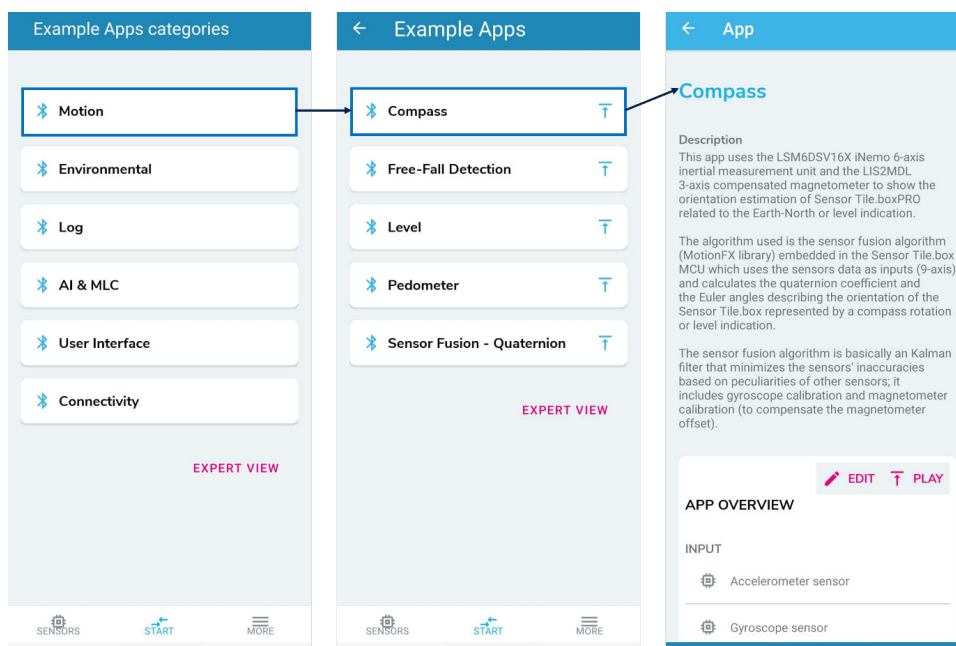
Figure 27. Example of the compass application on the ST BLE Sensor Classic app

For further details, please refer to the dedicated documents available at www.st.com.

3.2 Expert mode

In expert mode the user can build custom applications through the **ST BLE Sensor Classic** app by selecting specific input data and operating parameters. From the corresponding available in-box sensors, functions to assess/compute those data, and output types that the user needs, while leveraging the available powerful algorithms.

There are 3 main steps to create a new application:

1. **INPUT** - choose one of the sensors available on the board as an input
 - Multiple sensors can be selected at the same time, if they are compatible
 - After selecting the sensor, the options can be modified, like ODR and acquisition time, clicking on the gear symbol on the right
2. **FUNCTION** - choose a corresponding function to use on data (optional)
 - Keep in mind that some functions must have more than one input sensor, and some functions may not be available for some sensors
 - Functions also have options that can be modified with the gear symbol on the right
3. **OUTPUT** - choose an output for displaying the results
 - File to microSD™ card is for saving data on the sd-card
 - Stream to USB is for sending data through USB
 - Stream to Bluetooth® is for sending the results on the phone app
 - Save as input is for having this result as an input to a new application (available only for some demo flows)

For further details, please refer to the dedicated documents available at www.st.com.

3.3 Pro mode

Pro mode: quickly develop tailored IoT applications taking advantage of the STM32 open development environment (ODE) and STMicroelectronics function pack libraries, including:

- FP-SNS-BLEMESH1
- FP-ATR-BLE1 (running in STM32U5)
- FP-SNS-DATALOG2

For further details, please refer to the webpage FP-SNS-STBOX1.

Figure 29. Sensortilebox_pro_Power

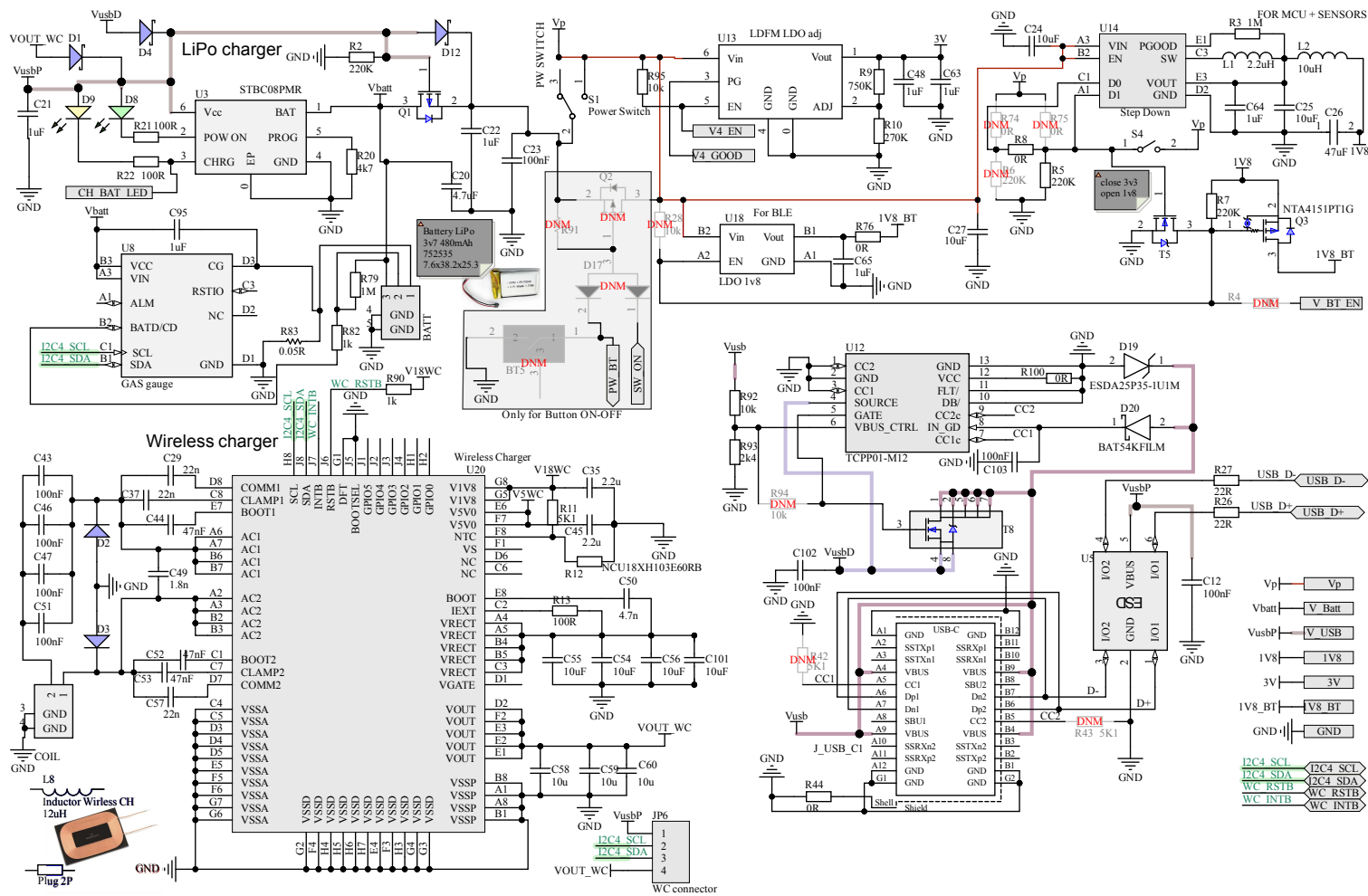

Figure 30. Sensortilebox_pro_MCU

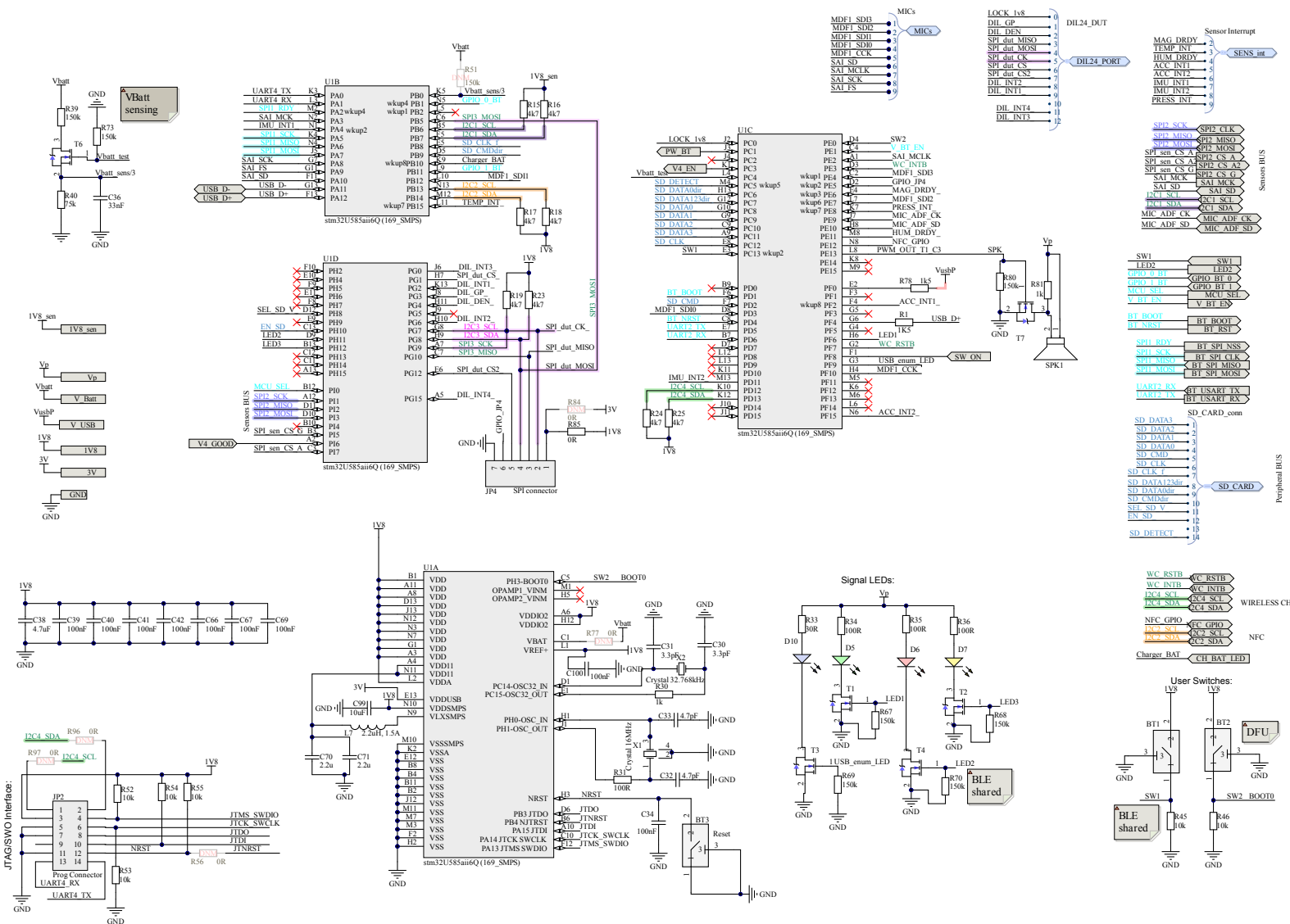

Figure 31. Sensortilebox_pro_sensors

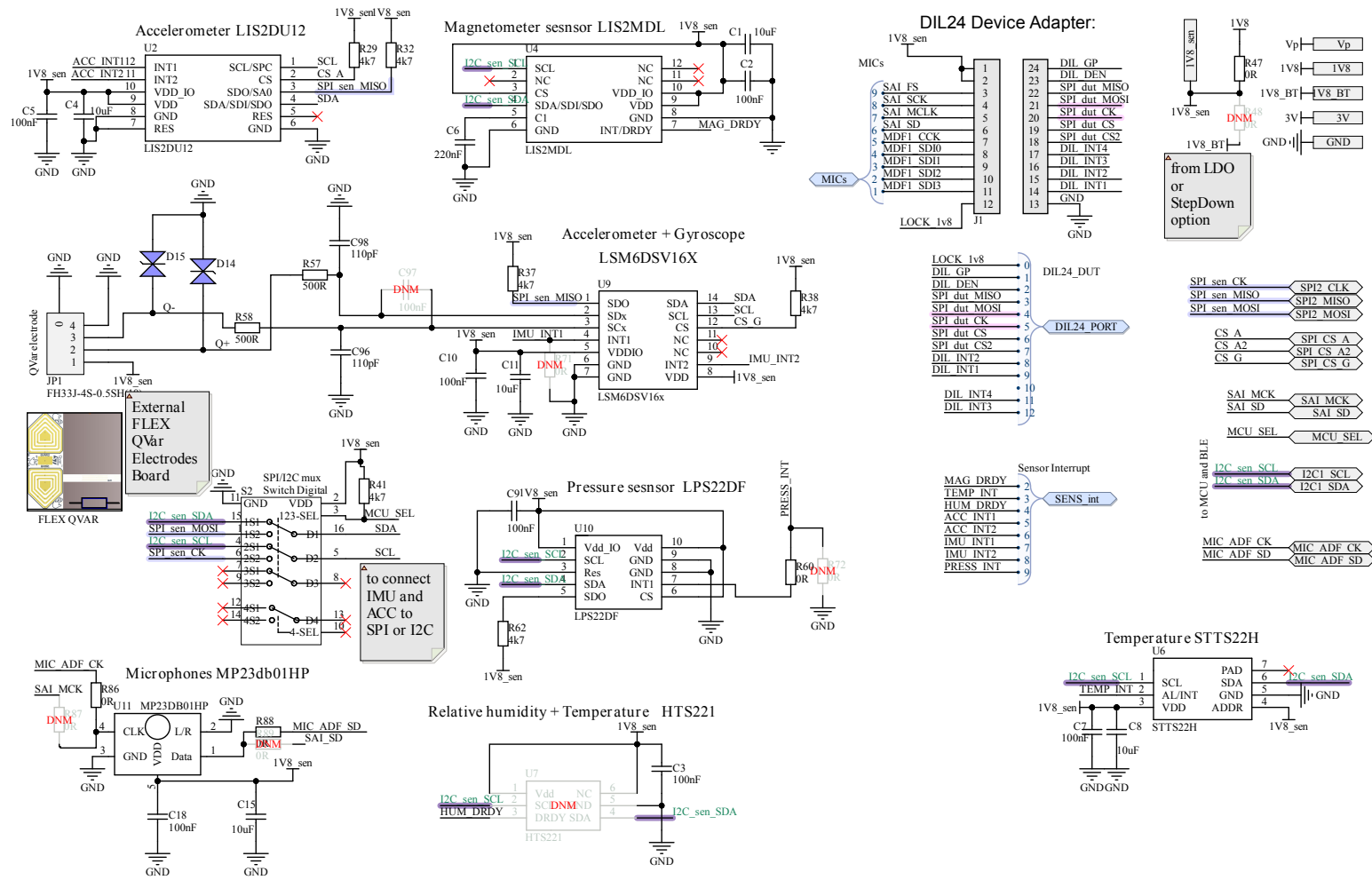
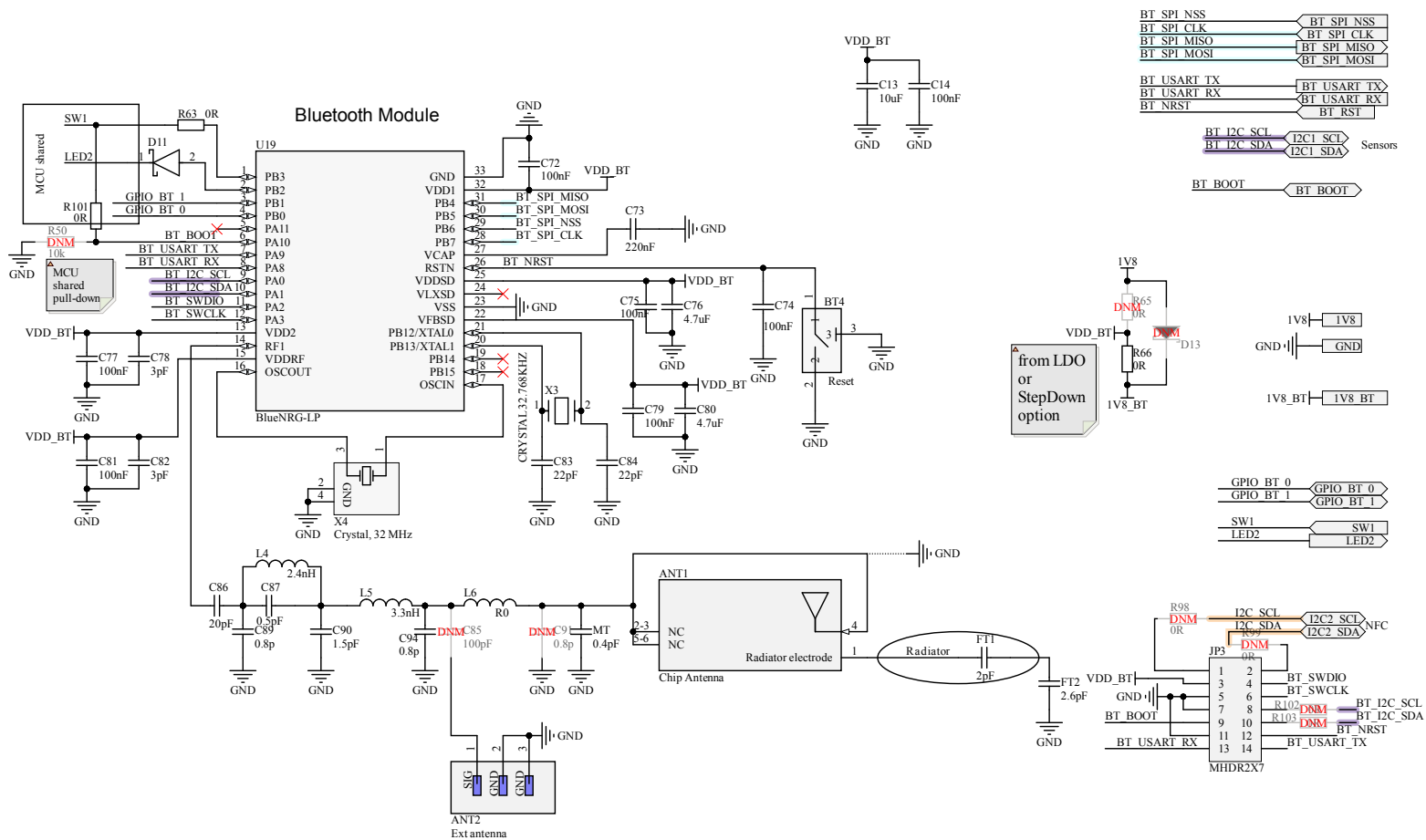

Figure 32. Sensortilebox_pro_BLE



NOTE: ANT2 is physically unconnected, in fact C85 and C91 are not mounted (DNM means Do Not Mount) and their absence isolate the ANT2 connector by the circuitry.



Figure 33. Sensortilebox_pro_Peripherals

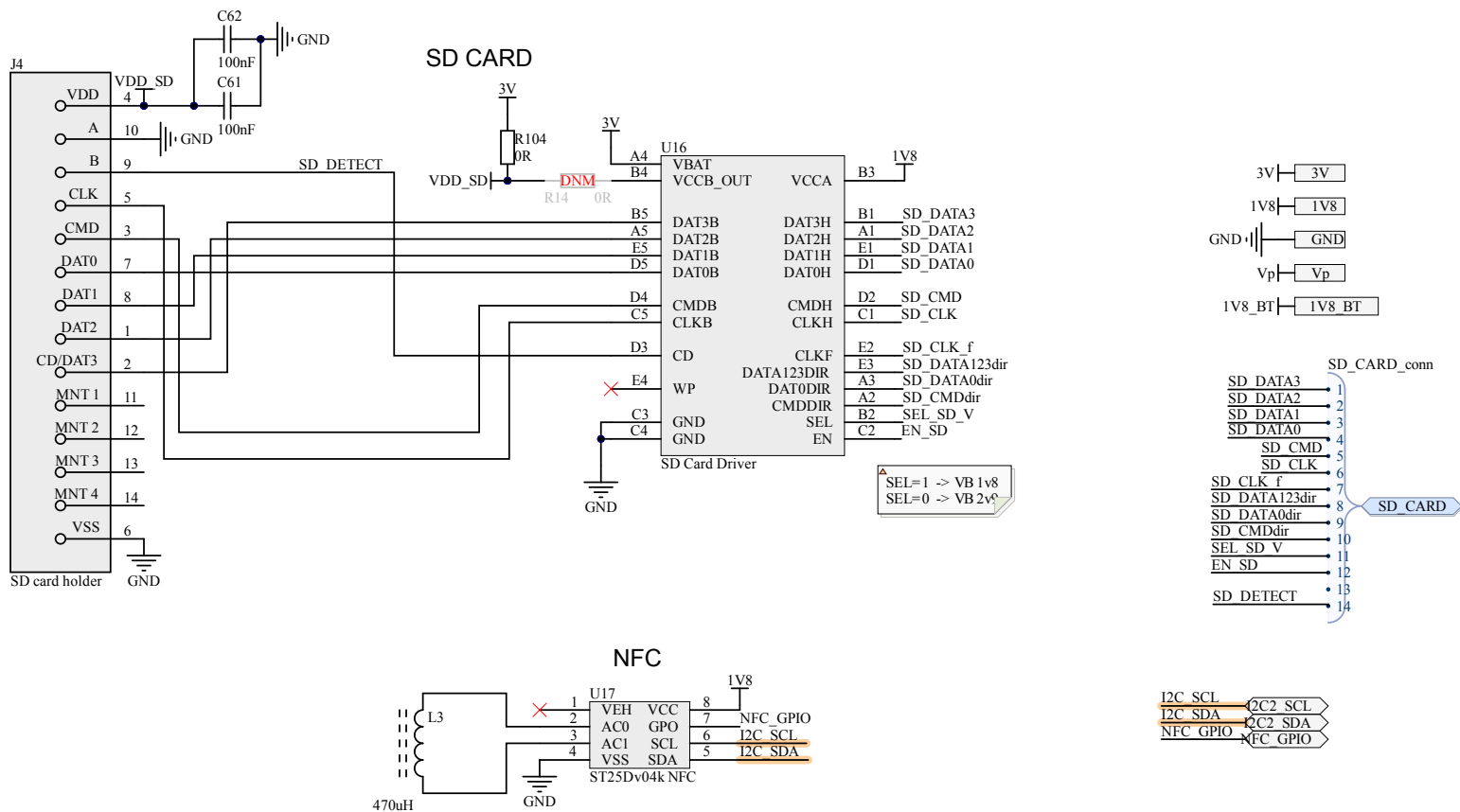

5 Bill of materials

Table 8. BOM

Item	Q.ty	Ref.	Part/value	Description	Manufacturer	Order code
1	4	BT1, BT2, BT3, BT4	B3U-3100P	Switch button	Omron	B3U-3100P
2	1	S2	STG3692QTR, VFQFPN 16 2.6x1.8x0.5	Switch digital	STMicroelectro nics	STG3692QTR
3	1	U2	LIS2DU12	LIS2DU12TR, LGA 2X2X0.74MAX 12 LEADS	STMicroelectro nics	LIS2DU12TR
4	1	U3	STBC08PMR, VFDFPN 6 3x3	LiPo charger	STMicroelectro nics	STBC08PMR
5	1	U4	LIS2MDLTR, LGA2X2X0.7 12 LEADS	LIS2MDL	STMicroelectro nics	LIS2MDLTR
6	1	U6	STTS22HTR, UDFN 2X2X.55 6L PITCH0.65	STTS22H	STMicroelectro nics	STTS22HTR
7	1	U9	LSM6DSV16XTR, VFLGA2.5X3X.86 14L P.5 L.475X.25	LSM6DSV16x	STMicroelectro nics	LSM6DSV16XTR
8	1	U10	LPS22DF	LPS22DF	STMicroelectro nics	LPS22DF
9	1	U11	MP23DB01HP, RHLGA 3.5X2.65X0.98 mm 4L	MP23DB01HP	STMicroelectro nics	MP23DB01HPTR
10	1	U13	LDFMPVR, DFN6 2x2	LDFM LDO adj	STMicroelectro nics	LDFMPVR
11	1	U14	ST1PS01EJR, CSP P 0.4 mm	Step down	STMicroelectro nics	ST1PS01EJR
12	1	U16	ST6G3244MEBJR	SD card driver	STMicroelectro nics	ST6G3244MEBJR
13	1	U17	ST25DV04K- IER8C3, UDFPN 8 2x3x0.6	ST25DV04K NFC	STMicroelectro nics	ST25DV04K-IER8C3
14	1	U18	LD39115J18R, CSP P 0.4 mm	LDO 1v8	STMicroelectro nics	LD39115J18R
15	1	U19	BLUENRG 355AC, VFQFPN 32 5x5x1.0 mm	BlueNRG-LP	STMicroelectro nics	BLUENRG 355AC
16	1	U20	STWLC68JRH, STWLC68	Wireless charger	STMicroelectro nics	STWLC68JRH
17	1	U1	STM32U585AI16Q, UFBGA 169 7x7x0.6 P 0.5 mm	STM32U585AI16Q (169_SMPS)	STMicroelectro nics	STM32U585AI16Q
18	1	U8	STC3115AIJT, CSP P 0.4 mm	GAS gauge	STMicroelectro nics	STC3115AIJT
19	1	FLEX Qvar	FLEX Qvar	FLEX Qvar	STMicroelectro nics	QV EL V2.1
20	1	MT	0.4 pF	Capacitor	MURATA	GRM0334C1HR40WA 01

Item	Q.ty	Ref.	Part/value	Description	Manufacturer	Order code
21	1	U12	TCPP01-M12, QFN-12L	TCPP01-M12	STMicroelectronics	TCPP01-M12
22	2	R57, R58	500R	Resistor	VISHAY	PLT0603Z5000AST5
23	1	C44	47 nF	Capacitor	MURATA	GRM155R71H473KE14D
24	1	C26	47 uF	GRM188R60G476ME15D	MURATA	GRM188R60G476ME15D
25	2	C52, C53	47 nF	Capacitor	MURATA	GRM155R71H473KE14D
26	2	D2, D3	SMAJ16A-E3/61	Protection diode	Vishay Semiconductor	SMAJ16A-E3/61
27	1	FT1	2 pF	Capacitor	MURATA	GRM0335C1H2R0BA01D
28	1	T8	STL6N3LLH6, PowerFLAT 2x2	MOSFET-P+D_(G-3,S-(4+Ex2),D-(1256+Ex1))_w_box	STMicroelectronics	STL6N3LLH6
29	3	D1, D4, D12	ZLLS400QTA	Schottky diode	ON SEMICONDUCTOR	ZLLS400QTA
30	1	FT2	2.6 pF	Capacitor	MURATA	GJM0335C1H2R6BB01D
31	2	JP2, JP3	FTSH-107-01-L-D	Prog connector, MHDR2X7	Samtec	FTSH-107-01-L-D
32	1	J_USB_C1	632723100011	USB Type-C®	Würth Elektronik	632723100011
33	1	JP4	MC-SVT1-S07-G	SPI connector 1x7	Multicomp	MC-SVT1-S07-G
34	1	JP6	MC-SVT1-S04-G	WC connector	Multicomp	MC-SVT1-S04-G
35	1	Q1	STR2P3LLH6, SOT-23	P-MOS	STMicroelectronics	STR2P3LLH6
36	1	D19	ESDA25P35-1U1M, QFN-2L	ESDA25P35-1U1M	STMicroelectronics	ESDA25P35-1U1M
37	1	R33	30R	Resistor	Multicomp	MCWR04X30R0FTL
38	1	L6	R0	Inductor	Multicomp	MCWR04X000 PTL
39	1	C50	4.7 n	Capacitor	MURATA	GCM155R71H472KA37D
40	2	C32, C33	4.7 pF	Capacitor	Multicomp	MC0402N4R7C500CT
41	2	C30, C31	3.3 pF	Capacitor	Multicomp	MC0402N3R3C500CT
42	1	C99	10 uF	Capacitor	MURATA	GRM155R60G106ME44
43	1	SPK1	PKMCS0909E4000-R1	Speaker Piezo	MURATA	2529461
44	3	C58, C59, C60	10 u	Capacitor	TDK	C1608X5R1E106M080AC
45	1	ANT1	ANT016008LCS2442MA1	Chip antenna	TDK	ANT016008LCS2442MA1
46	1	X2	ABS06-107-32.768KHZ-T	Crystal 32.768 kHz	ABRACON	ABS06-107-32.768KHZ-T

Item	Q.ty	Ref.	Part/value	Description	Manufacturer	Order code
47	4	C43, C46, C47, C51	100 nF	Cap	TDK	CGA3E2X7R1H104K080AA
48	1	L2	10 uH	Inductor	TDK	VLS252012HBX-100M-1
49	2	L1, L7	2.2 uH	Inductor	TDK	VLS252010HBX-2R2M-1
50	2	R20, R62	4k7	Resistor	Multicomp	MCWR06X4701FTL
51	1	R40	75k	Resistor	Multicomp	MCWR04X7502FTL
52	1	R11	5K1	Resistor	Multicomp	MCWR04X5101FTL
53	1	R10	270 K	Resistor	Multicomp	MCWR04X2703FTL
54	1	S4	TDA01H0SB1R	TDA01H0SB1R	C&K COMPONENTS	TDA01H0SB1R
55	1	J4	DM3AT-SF-PEJM5	SD card holder	HIROSE	DM3AT-SF-PEJM5
56	1	L8	12 uH	Inductor wireless CH	Wurth	760308103202 WE
57	5	R47, R60, R66, R76, R85	0R	Resistor	Multicomp	MC0603SAF0000T5E
58	7	C21, C22, C48, C63, C64, C65, C95	1 uF	Capacitor	TDK	C1005X5R1E105K050BC
59	4	C20, C38, C76, C80	4.7 uF	Capacitor	TDK	C1005X5R1A475M050BC
60	2	D11, D20	BAT54KFILM, SOD-523	BAT54KFILM	STMicroelectronics	BAT54KFILM
61	29	C2, C3, C5, C7, C9, C10, C12, C14, C18, C23, C34, C39, C40, C41, C42, C61, C62, C66, C67, C69, C72, C74, C75, C77, C79, C81, C100, C102, C103	100 nF	Capacitor	Multicomp	MC0402B104K250CT
62	1	Q3	NTA4151PT1G	NTA4151PT1G	On Semiconductor	NTA4151PT1G
63	7	T1, T2, T3, T4, T5, T6, T7	NTA4153NT1G	MOSFET-N+D_(G1,S2,D3), MOSFET-N	ON Semi	NTA4153NT1G
64	1	COIL	78171-0002	Connector 2pol	MOLEX	78171-0002
65	1	BATT	Battery Conn. 3 p	JUMPER2	MOLEX	78171-0003
66	1	R93	2k4	Resistor	PANASONIC	ERJ-2RKf2401X
67	1	R83	0.05R	0.05	Panasonic	ERJ8CWFR050V
68	1	D10	KPT-1608QBC-D	LED_BLUE	Kingbright	KPT-1608QBC-D

Item	Q.ty	Ref.	Part/value	Description	Manufacturer	Order code
69	1	C36	33 nF	Capacitor	TDK	CGA2B3X7R1H333K050BB
70	4	R30, R81, R82, R90	1 k	Resistor	Multicomp	MC00625W040211K
71	2	D7, D9	KPT-1608YC	LED_ORANGE, 588nm	Kingbright	KPT-1608YC
72	2	D5, D8	KPT-1608SGC	LED_GREEN	Kingbright	KPT-1608SGC
73	1	D6	KPT-1608EC	LED_RED	Kingbright	KPT-1608EC
74	1	R9	750 K	Resistor	Multicomp	MCMR04X7503FTL
75	13	R15, R16, R17, R18, R19, R23, R24, R25, R29, R32, R37, R38, R41	4k7	Resistor	Multicomp	MCMR04X4701FTL
76	3	R2, R5, R7	220 K	Resistor	Multicomp	MCMR04X2203FTL
77	2	R3, R79	1 M	Resistor	Multicomp	MCMR04X1004FTL
78	1	S1	SSAJ120100	Power switch	ALPS	SSAJ120100
79	3	C29, C37, C57	22 n	Capacitor	MURATA	GRM155R71H223KA12D
80	1	L3	470 uH	SDR0805-4R7ML	Bourns	SDR0805-4R7ML
81	10	C1, C4, C8, C11, C13, C15, C54, C55, C56, C101	10 uF	Capacitor	Multicomp	MC0603X106M6R3C T
82	2	C96, C98	110 pF	Capacitor	Multicomp	MC0402N111J500CT
83	1	ANT2	U.FL-R-SMT-1(10)	Ext. antenna	HIROSE	U.FL-R-SMT-1(10)
84	2	C6, C73	220 nF	Capacitor	KEMET, Multicomp	C0603X224K4RACTU
85	7	R39, R67, R68, R69, R70, R73, R80	150 k	Resistor	Multicomp	MC00625W04021150 K
86	8	R45, R46, R52, R53, R54, R55, R92, R95	10 k	Resistor	Multicomp	MC00625W0402110K
87	2	R1, R78	1K5	Resistor	Multicomp	MC00625W040211K5
88	7	R13, R21, R22, R31, R34, R35, R36	100R	Resistor	Multicomp	MC00625W04021100 R
89	2	R26, R27	22R	Resistor	Multicomp	MC00625W0402122R
90	8	R8, R44, R63, R86, R88, R100, R101, R104	0R	Resistor	Multicomp	MC00625W040210R
91	1	U5	USBLC6-2P6, SOT666	USB ESD protection	STMicroelectronics	USBLC6-2P6

Item	Q.ty	Ref.	Part/value	Description	Manufacturer	Order code
92	1	JP1	FH33J-4S-0.5SH(10)	FLEX connector 4p	Hirose	FH33J-4S-0.5SH(10)
93	1	X4	NX2016SA-26MHZ-EXS00A-CS06025-4	Crystal, 32 MHz	NDK	NX2016SA-32MHZ-EXS00A-CS06654
94	1	X3	NX2012SA-32.768KHZ-EXS00A-MU00389	Crystal 32.768 kHz	NDK America	NX2012SA-32.768KHZ-EXS00A-MU00389
95	1	X1	NX2520SA-16MHZ-STD-CSW-5	Crystal 16 MHz	NDK	NX2520SA-16MHZ-STD-CSW-5
96	1	J1	BL1-036-G-700-01	ADAPTER_DIL24	ETEC	BL1-036-G-700-01
97	1	Plug 2P	Plug 2P	Connector plug 2P	MOLEX	36920-0201
98	1	L4	2.4 nH	Inductor	MURATA	LQG15HS2N4B02D
99	1	R12	NCU18XH103E60RB	NTC	MURATA	NCU18XH103E60RB
100	4	C35, C45, C70, C71	2.2 u	Capacitor	MURATA	GRM155R61E225KE11D
101	1	C49	1.8 n	Capacitor	MURATA	GRM155R71H182JA01D
102	1	L5	3.3 nH	Inductor	MURATA	LQP15MN3N3W02D
103	2	C89, C94	0.8 p	Capacitor	MURATA	GRM1555C1HR80BA01J
104	2	C78, C82	3 pF	Capacitor	MURATA	GRM1555C1H3R0BA01D
105	1	C86	20 pF	Capacitor	MURATA	GRM1555C1H200GA01
106	1	C87	0.5 pF	Capacitor	MURATA	GRM1555C1HR50CA01D
107	1	C90	1.5 pF	Capacitor	MURATA	GRM1555C1H1R5CA01D
108	3	C24, C25, C27	10 uF	Capacitor	MURATA	GRM188R60J106ME47D
109	2	C83, C84	22 pF	Capacitor	MURATA	GRM1555C1H220JZ01D
110	2	D14, D15	ESDALCL5-1BM2, SOD-882	ESDALCL5-1BM2	STMicroelectronics	ESDAXLC6-1BT2

6 Board versions

Table 9. STEVAL-MKBOXPRO versions

PCB version	Schematic diagrams	Bill of materials
STEVAL\$MKBOXPROA ⁽¹⁾	STEVAL\$MKBOXPROA schematic diagrams	STEVAL\$MKBOXPROA bill of materials

1. This code identifies the STEVAL-MKBOXPRO evaluation board first version. It is printed on the board PCB.

7 Regulatory compliance information

Formal Notice Required by the U.S. Federal Communications Commission

Changes or modifications not expressly approved by the party responsible for compliance could void the user's authority to operate the equipment.

US Agent contact located in the United States:

Name: Francesco Doddo; address: STMicroelectronics Inc, 200 Summit Drive, Suite 405, Burlington MA, 01803, U.S.A.; e-mail: francesco.doddo@st.com

This device complies with part 15 of the FCC Rules. Operation is subject to the following two conditions:

- (1) This device may not cause harmful interference, and
 - (2) this device must accept any interference received, including interference that may cause undesired operation.
- Changes or modifications not expressly approved by the manufacturer could void the user's authority to operate the equipment.

Note:

This equipment has been tested and found to comply with the limits for a Class B digital device, pursuant to part 15 of the FCC Rules. These limits are designed to provide reasonable protection against harmful interference in a residential installation. This equipment generates, uses and can radiate radio frequency energy and, if not installed and used in accordance with the instructions, may cause harmful interference to radio communications. However, there is no guarantee that interference will not occur in a particular installation. If this equipment does cause harmful interference to radio or television reception, which can be determined by turning the equipment off and on, the user is encouraged to try to correct the interference by one or more of the following measures:

- *Reorient or relocate the receiving antenna.*
- *Increase the separation between the equipment and receiver.*
- *Connect the equipment into an outlet on a circuit different from that to which the receiver is connected.*
- *Consult the dealer or an experienced radio/TV technician for help.*

Radio Frequency (RF) Exposure Information for USA

This product complies with FCC radiation exposure limits set forth for an uncontrolled environment. The antenna should be installed and operated with minimum distance of ≥ 20 cm between the radiator and your body.

Formal Product Notice Required by Industry Canada

Changes or modifications not expressly approved by the party responsible for compliance could void the user's authority to operate the equipment.

Responsible party's contact located in Canada: name: John Langner; address: STMicroelectronics, Inc., 350 Burnhamthorpe Road West, Suite 303 L5B 3J1, Mississauga, ON, Canada; e-mail: john.langner@st.com

Innovation, Science and Economic Development Canada Compliance

This device contains licence-exempt transmitter(s)/receiver(s) that comply with Innovation, Science and Economic Development Canada's licence exempt RSS(s). Operation is subject to the following two conditions:

- (1) This device may not cause interference.
- (2) This device must accept any interference, including interference that may cause undesired operation of the device.

This radio transmitter has been approved by Innovation, Science and Economic Development Canada with the maximum permissible gain indicated.

This device complies with Health Canada's Safety Code. The installer of this device should ensure that RF radiation is not emitted in excess of the Health Canada's requirement.

This class B device complies with Canadian Interference-Causing Equipment Standard ICES-003: CAN ICES-003(B) / NMB-003(B)

Conformité à Innovation, Sciences et Développement Économique Canada

L'émetteur/recepteur exempt de licence contenu dans le present appareil est conforme aux CNR d'Innovation, Sciences et Développement économique Canada applicables aux appareils radio exempts de licence.

L'exploitation est autorisée aux deux conditions suivantes: (1) L'appareil ne doit pas produire de brouillage; (2) L'appareil doit accepter tout brouillage radioélectrique subi, même si le brouillage est susceptible d'en compromettre le fonctionnement.

Le présent émetteur radio a été approuvé par Innovation, Sciences et Développement économique Canada pour fonctionner avec un gain admissible maximal.

Cet appareil est conforme avec Santé Canada Code de sécurité 6. Le programme d'installation de cet appareil doit s'assurer que les rayonnements RF n'est pas émis au-delà de l'exigence de Santé Canada.

Cet appareil numérique de classe B est conforme à la Norme sur le matériel brouilleur NMB-003 du Canada: CAN ICES-003(B) / NMB-003(B)

Radio Frequency (RF) Exposure Information for Canada

This product complies with Innovation, Science and Economic Development Canada (ISED) radiation exposure limits set forth for an uncontrolled environment. The antenna should be installed and operated with minimum distance of ≥ 20 cm between the radiator and your body.

Cet appareil est conforme aux limites d'exposition aux rayonnements de l'Innovation, Sciences et Développement économique Canada (ISDE) pour un environnement non contrôlé. L'antenne doit être installée de façon à garder une distance minimale de ≥ 20 centimètres entre la source de rayonnements et votre corps.

Notice for the European Union

The kit STEVAL-MKBOXPRO is in conformity with the essential requirements of the Directive 2014/53/EU (RED) and of the Directive 2015/863/EU (RoHS). Applied harmonized standards are listed in the EU Declaration of Conformity.

Notice for United Kingdom

The kit STEVAL-MKBOXPRO is in compliance with the UK Radio Equipment Regulations 2017 (UK SI 2017 No. 1206 and amendments) and with the Restriction of the Use of Certain Hazardous Substances in Electrical and Electronic Equipment Regulations 2012 (UK SI 2012 No. 3032 and amendments). Applied standards are listed in the UK Declaration of Conformity.

Revision history

Table 10. Document revision history

Date	Revision	Changes
27-Mar-2023	1	Initial release.
13-Jun-2023	2	Updated Section 1.7.3.2 Wireless charging, Section 3.1 Entry mode and Section 7 Regulatory compliance information.
12-Jul-2023	3	Updated Section 1.3 RF specifications, Figure 32. Sensortilebox_pro_BLE and Figure 32. Sensortilebox_pro_BLE. Added Section 2.4 Troubleshooting.

Contents

1	Getting started	2
1.1	Precaution for use	2
1.2	Features	2
1.3	RF specifications	3
1.4	Kit components	3
1.5	Layout of the STEVAL-MKBOXPRO	4
1.6	Core system board	6
1.7	Functional blocks	8
1.7.1	Sensing	8
1.7.2	Processing and connectivity	12
1.7.3	Power options	16
1.8	User interface options	19
1.8.1	Programmable LEDs	20
1.8.2	Programmable buttons	20
1.8.3	Buzzer	20
1.8.4	Qvar	21
1.8.5	Socket DIL24	21
1.8.6	Interface for extension board	21
2	How to program the board	22
2.1	Restore to factory settings	22
2.2	How to program the SensorTile.box PRO in “DFU mode” (via USB)	22
2.3	How to program the SensorTile.box PRO with an external debugger	22
2.4	Troubleshooting	23
3	Development applications	27
3.1	Entry mode	27
3.2	Expert mode	28
3.3	Pro mode	28
4	Schematic diagrams	29
5	Bill of materials	35
6	Board versions	40
7	Regulatory compliance information	41
	Revision history	43
	List of tables	45
	List of figures	46

List of tables

Table 1.	Precautions for use	2
Table 2.	LPS22DF I/O configuration	9
Table 3.	STTS22H I/O configuration	10
Table 4.	LSM6DSV16X I/O configuration	10
Table 5.	LIS2DU12 I/O configuration	11
Table 6.	LIS2MDL I/O configuration	11
Table 7.	MP23DB01HP I/O configuration	11
Table 8.	BOM	35
Table 9.	STEVAL-MKBOXPRO versions	40
Table 10.	Document revision history	43

List of figures

Figure 1.	STEVAL-MKBOXPRO (SensorTile.box PRO) multi-sensor and wireless connectivity development kit	1
Figure 2.	STEVAL-MKBOXPRO components	3
Figure 3.	Layout of the core system board components - top	4
Figure 4.	Layout of the core system board components - bottom	5
Figure 5.	STEVAL-MKBOXPRO block diagram.	6
Figure 6.	STEVAL-MKBOXPRO evaluation kit - top view	7
Figure 7.	STEVAL-MKBOXPRO evaluation kit - bottom view	7
Figure 8.	STEVAL-MKBOXPRO - overview of the sensing components.	8
Figure 9.	STEVAL-MKBOXPRO - sensors on the top side	8
Figure 10.	STEVAL-MKBOXPRO - sensors on the bottom side	9
Figure 11.	Main connectivity components and the STM32U585AI processing unit.	12
Figure 12.	MCU and connectivity components (top view).	12
Figure 13.	MCU and connectivity components (bottom view)	13
Figure 14.	Power management of the SensorTile.box PRO core system board.	16
Figure 15.	Power components - top view	16
Figure 16.	Power components - bottom view	17
Figure 17.	SensorTile.box PRO user interface	19
Figure 18.	User interface components.	20
Figure 19.	SensorTile.box PRO Qvar electrodes	21
Figure 20.	SensorTile.box PRO DIL24 socket	21
Figure 21.	Example of a board shown with no database entry	23
Figure 22.	MORE tab in ST BLE Sensor Classic app	23
Figure 23.	Browser screen example where to download the json file	24
Figure 24.	Add Custom Fw Db Entry screen	25
Figure 25.	Example of board shown with custom database entry	25
Figure 26.	Firmware Download screen	26
Figure 27.	Example of the compass application on the ST BLE Sensor Classic app	28
Figure 28.	Sensortilebox_pro_main	29
Figure 29.	Sensortilebox_pro_Power	30
Figure 30.	Sensortilebox_pro_MCU	31
Figure 31.	Sensortilebox_pro_sensors	32
Figure 32.	Sensortilebox_pro_BLE	33
Figure 33.	Sensortilebox_pro_Peripherals	34

IMPORTANT NOTICE – READ CAREFULLY

STMicroelectronics NV and its subsidiaries (“ST”) reserve the right to make changes, corrections, enhancements, modifications, and improvements to ST products and/or to this document at any time without notice. Purchasers should obtain the latest relevant information on ST products before placing orders. ST products are sold pursuant to ST’s terms and conditions of sale in place at the time of order acknowledgment.

Purchasers are solely responsible for the choice, selection, and use of ST products and ST assumes no liability for application assistance or the design of purchasers’ products.

No license, express or implied, to any intellectual property right is granted by ST herein.

Resale of ST products with provisions different from the information set forth herein shall void any warranty granted by ST for such product.

ST and the ST logo are trademarks of ST. For additional information about ST trademarks, refer to www.st.com/trademarks. All other product or service names are the property of their respective owners.

Information in this document supersedes and replaces information previously supplied in any prior versions of this document.

© 2023 STMicroelectronics – All rights reserved