

FCC PART 15 SUBPART 247



MEASUREMENT AND TEST REPORT

For

**Ruckus Wireless, Inc.**

883 North Shoreline Blvd, Suite A-100  
Mountain View CA, USA 94043

FCC ID: S9GVX2XX1  
Model: ZX2XX1

|   |  |   |
|---|--|---|
| <b>This Report Concerns:</b><br><input checked="" type="checkbox"/> Class II Permissive Change Report |  | <b>Product type:</b><br>Wireless 802.11b/g Router |
| <b>Test Engineer:</b>   | Oscar Au    |   |
| <b>Report Number:</b>   | R0612202-247   |   |
| <b>Report Date:</b>   | 2007-01-15   |   |
| <b>Reviewed By:</b>   | Hans Mellberg, VP of Engineering                          |   |
| <b>Prepared By:</b><br>(12)   | <b>Bay Area Compliance Laboratories Corp.</b><br>1274 Anvilwood Ave.<br>Sunnyvale, CA 94089, USA<br>Tel: (408) 732-9162<br>Fax: (408) 732 9164 |   |

**Note:** This test report is for the customer shown above and their specific product only. It may not be duplicated or used in part without prior written consent from Bay Area Compliance Laboratories Corp. This report **must not** be used by the customer to claim product certification, approval, or endorsement by NVLAP, NIST, or any agency of the Federal Government.

## TABLE OF CONTENTS

|          |  |           |
|----------|--|-----------|
| <b>1</b> | <b>GENERAL INFORMATION .....</b>   | <b>4</b>  |
| 1.1      | PRODUCT DESCRIPTION FOR EQUIPMENT UNDER TEST (EUT) .....                         | 4         |
| 1.2      | EUT PHOTO .....  | 4         |
| 1.3      | MECHANICAL DESCRIPTION .....   | 4         |
| 1.4      | OBJECTIVE .....  | 5         |
| 1.5      | RELATED SUBMITTAL(S)/GRANT(S).....   | 5         |
| 1.6      | TEST METHODOLOGY .....   | 5         |
| 1.7      | MEASUREMENT UNCERTAINTY .....  | 5         |
| 1.8      | TEST FACILITY .....  | 6         |
| <b>2</b> | <b>SYSTEM TEST CONFIGURATION .....</b>   | <b>7</b>  |
| 2.1      | JUSTIFICATION .....  | 7         |
| 2.2      | EQUIPMENT MODIFICATIONS .....  | 7         |
| 2.3      | LOCAL SUPPORT EQUIPMENT LIST AND DETAILS .....                                   | 7         |
| 2.4      | POWER SUPPLY INFORMATION .....   | 7         |
| 2.5      | INTERFACE PORTS AND CABLING .....  | 7         |
| 2.6      | PRINTED CIRCUIT BOARDS IN EUT .....  | 7         |
| <b>3</b> | <b>SUMMARY OF TEST RESULTS.....</b>  | <b>8</b>  |
| <b>4</b> | <b>§15.203 - ANTENNA REQUIREMENT .....</b>                                       | <b>9</b>  |
| 4.1      | APPLICABLE STANDARD .....  | 9         |
| 4.2      | RESULT .....   | 9         |
| <b>5</b> | <b>§1.1307(B) (1), §2.1091 - RF EXPOSURE.....</b>                                | <b>10</b> |
| <b>6</b> | <b>§15.205 &amp; §15.209 &amp; §15.247(C) - SPURIOUS RADIATED EMISSION .....</b> | <b>12</b> |
| 6.1      | APPLICABLE STANDARD .....  | 12        |
| 6.2      | TEST SETUP.....  | 13        |
| 6.3      | TEST EQUIPMENT LIST AND DETAILS .....  | 13        |
| 6.4      | TEST SETUP BLOCK DIAGRAM .....   | 13        |
| 6.5      | TEST PROCEDURE .....   | 14        |
|          | CORRECTED AMPLITUDE & MARGIN CALCULATION .....                                   | 14        |
| 6.6      | SUMMARY OF TEST RESULTS .....  | 15        |
| <b>7</b> | <b>EXHIBIT A - FCC ID LABEL INFORMATION.....</b>                                 | <b>20</b> |
| 7.1      | FCC § 2.925 IDENTIFICATION OF EQUIPMENT .....                                    | 20        |
| 7.2      | ID LABEL REQUIREMENTS AS PER FCC § 15.19.....                                    | 20        |
| 7.3      | PROPOSED FCC ID LABEL .....  | 20        |
| 7.4      | PROPOSED LABEL ON EUT (BOTTOM VIEW).....   | 21        |
| <b>8</b> | <b>EXHIBIT B - TEST SETUP PHOTOGRAPHS.....</b>                                   | <b>22</b> |
| 8.1      | RADIATED EMISSION – FRONT VIEW.....  | 22        |
| 8.2      | RADIATED EMISSION – REAR VIEW .....  | 22        |
| <b>9</b> | <b>EXHIBIT C - EUT PHOTOGRAPHS .....</b>   | <b>23</b> |
| 9.1      | EUT – TOP VIEW .....   | 23        |
| 9.2      | EUT – BOTTOM VIEW .....  | 23        |
| 9.3      | EUT – COVER OFF VIEW .....   | 24        |
| 9.4      | EUT – MAIN BOARD COMPONENT VIEW .....  | 24        |
| 9.5      | EUT – MAIN BOARD SOLDER VIEW.....  | 25        |
| 9.6      | EUT – TX CLOSE UP .....  | 25        |
| 9.7      | EUT – ANTENNA VIEW 1 .....   | 26        |
| 9.8      | EUT – ANTENNA VIEW 2 .....   | 26        |
| 9.9      | EUT – PORT VIEW .....  | 27        |
| 9.10     | POWER SUPPLY TYPE 1-1 (FRONT).....   | 27        |
| 9.11     | POWER SUPPLY TYPE 1-1 (REAR).....  | 28        |
| 9.12     | POWER SUPPLY TYPE 1-2 (FRONT).....   | 28        |

9.13 POWER SUPPLY TYPE 1-2 (REAR).....29  
9.14 POWER SUPPLY TYPE 1-3 (FRONT).....29  
9.15 POWER SUPPLY TYPE 1-3 (REAR).....30  
9.16 POWER SUPPLY TYPE 2-1 (FRONT).....30  
9.17 POWER SUPPLY TYPE 2-1 (REAR).....31  
9.18 POWER SUPPLY TYPE 2-2 (FRONT).....31  
9.19 POWER SUPPLY TYPE 2-2 (REAR).....32  
9.20 POWER SUPPLY TYPE 2-3 (FRONT).....32  
9.21 POWER SUPPLY TYPE 2-3 (REAR).....33  
9.22 POWER SUPPLY TYPE 3-1 (FRONT).....33  
9.23 POWER SUPPLY 3-1 (REAR).....34  
9.24 POWER SUPPLY TYPE 3-2 (FRONT).....34  
9.25 POWER SUPPLY TYPE 3-2 (REAR).....35  
9.26 POWER SUPPLY TYPE 3-3 (FRONT).....35  
9.27 POWER SUPPLY TYPE 3-3 (REAR).....36

## 1 GENERAL INFORMATION

### 1.1 Product Description for Equipment under Test (EUT)

The *Ruckus Wireless, Inc.* product, FCC ID: *S9GVX2XX1* the "EUT" as referred to in this report is a Wireless 802.11b/g Router that transmits and receives digital information at a rate from 11Mbps – 54 Mbps in the 2.4 GHz frequency band (2412.00 - 2462.00MHz). This device is designed for home use and receives power via AC/DC adapter with switching power supply functions for various countries of deployment. This EUT features a single LAN input port.

### 1.2 EUT Photo



### 1.3 Mechanical Description

The EUT is a mobile device which measures approximately 233mmL x 153mmW x 75mmH.

*\* The test data gathered are from production sample, serial number: VF40000005 Revision: #1, provided by the manufacturer.*

## 1.4 Objective

This type approval report is prepared on behalf of *Ruckus Wireless* in accordance with Part 2, Subpart J, Part 15, Subparts A, B, C and E of the Federal Communication Commissions rules.

The objective is to determine continued compliance with FCC 15.247 Standard's limits rules for Antenna Requirements and Radiated Spurious Emissions after the class II permissive change made by *Ruckus Wireless*.

FCC ID: S9GVX2XX1 is electrically identical to the device of the same FCC ID tested by BACL in project R0603171. The only change that has been made to the EUT is mechanical; a new antenna with a maximum gain of 4.5 dBi has replaced the original. Please refer to *Ruckus Wireless* Change Description letter filed along with this submission.

## 1.5 Related Submittal(s)/Grant(s)

This Permissive Change II report has been compiled on behalf of *Ruckus Wireless* and contains only those tests performed to verify continued compliance after the aforementioned change was made. The original FCC ID: S9GVX2XX1 was granted in May, 2006. Please refer to Bay Area Compliance Laboratories Corp. project number: R0603171 for complete tests and their results.

## 1.6 Test Methodology

All measurements contained in this report were conducted in accordance with ANSI C63.4-2003, American National Standard for Methods of Measurement of Radio-Noise Emissions from Low-Voltage Electrical and Electronic Equipment in the range of 9 kHz to 40 GHz.

## 1.7 Measurement Uncertainty

All measurements involve certain levels of uncertainties, especially in the field of EMC. The factors contributing to uncertainties are spectrum analyzer, cable loss, antenna factor calibration, antenna directivity, antenna factor variation with height, antenna phase center variation, antenna factor frequency interpolation, measurement distance variation, site imperfections, mismatch (average), and system repeatability.

Based on NIS 81, The Treatment of Uncertainty in EMC Measurements, the values ranging from  $\pm 2.0$  dB for Conducted Emissions tests and  $\pm 4.0$  dB for Radiated Emissions tests are the most accurate estimates pertaining to uncertainty of EMC measurements at BACL Corp.

Detailed instrumentation measurement uncertainties can be found in BACL Corp. report QAP-018.

## 1.8 Test Facility

The test site used by BACL Corp. to collect radiated and conducted emissions measurement data is located at its facility in Sunnyvale, California, USA.

The test site at BACL Corp. has been fully described in reports submitted to the Federal Communication Commission (FCC) and Voluntary Control Council for Interference (VCCI). The details of these reports have been found to be in compliance with the requirements of Section 2.948 of the FCC Rules on February 11, 1997 and December 10, 1997 and Article 8 of the VCCI regulations on December 25, 1997. The facility also complies with the test methods and procedures set forth in ANSI C63.4-2003 & TIA/EIA-603.

The Federal Communications Commission and Voluntary Control Council for Interference have the reports on file and they are listed under FCC registration number: 90464 and VCCI Registration No.: R-2463 and C-2698. The test site has been approved by the FCC and VCCI for public use and is listed in the FCC Public Access Link (PAL) database.

Additionally, BACL Corp. is a National Institute of Standards and Technology (NIST) accredited laboratory under the National Voluntary Laboratory Accredited Program (Lab Code 200167-0). The current scope of accreditations can be found at <http://ts.nist.gov/ts/htdocs/210/214/scopes/2001670.htm>.

## 2 SYSTEM TEST CONFIGURATION

### 2.1 Justification

The host system was configured for testing according to ANSI C63.4-2003.

The EUT was tested in the normal (native) operating mode to represent *worst*-case results during the final qualification test.

### 2.2 Equipment Modifications

No modifications were made to the EUT.

### 2.3 Local Support Equipment List and Details

| Manufacturer | Description | Model | Serial Number |
|--------------|-------------|-------|---------------|
| IBM          | Laptop PC   | T42   | N/A           |

### 2.4 Power Supply Information

| Manufacturer      | Description | Model              | Serial Number |
|-------------------|-------------|--------------------|---------------|
| DVE               | ADC Adaptor | DSA-0131F-12 US 12 | N/A           |
| DVE               | ADC Adaptor | DSA-12W-10 Fxx     | N/A           |
| Leader Electronic | ADC Adaptor | MU-12-2120100-A1   | N/A           |

### 2.5 Interface Ports and Cabling

| Cable Description       | Length (M) | From                | To                 |
|-------------------------|------------|---------------------|--------------------|
| Shielded Ethernet Cable | 2.0        | Ethernet port / EUT | Ethernet Port / PC |

### 2.6 Printed Circuit Boards in EUT

| Manufacturer    | Description | Model/Rev. | Serial Number |
|-----------------|-------------|------------|---------------|
| Ruckus Wireless | Main Board  | Rev. D     | N/A           |

### 3 SUMMARY OF TEST RESULTS

Results reported relate only to the product tested.

| FCC RULES                | DESCRIPTION OF TEST                         | RESULT     |
|--------------------------|---|------------|
| §2.1091,<br>§15.247(f)   | RF Exposure Requirement                     | Compliant  |
| §15.203<br>§15.247(b)(4) | Antenna Requirement                         | Compliant  |
| § 15.205                 | Restricted Bands                            | Compliant* |
| § 15.207(a)              | AC Line Conducted Emissions                 | Compliant* |
| §15.209(a), §15.247(d)   | Spurious Radiated Emissions                 | Compliant  |
| §2.1051, §15.247(d)      | Spurious Emissions At Antenna Terminals     | Compliant* |
| §15.247 (a)(2)           | 6 dB Bandwidth                              | Compliant* |
| §15.247 (b)(3)           | Maximum Peak Output Power                   | Compliant* |
| § 15.247 (d)             | 100 kHz Bandwidth of Frequency Band<br>Edge | Compliant* |
| §15.247 (e)              | Peak Power Spectral Density                 | Compliant* |

\* Please refer to BACL's project# R0603171 for original test data and photographs.



## 4 §15.203 - ANTENNA REQUIREMENT

### 4.1 Applicable Standard

According to § 15.203, an intentional radiator shall be designed to ensure that no antenna other than that furnished by the responsible party shall be used with the device. The use of a permanently attached antenna or of an antenna that uses a unique coupling to the intentional radiator shall be considered sufficient to comply with the provisions of this Section. The manufacturer may design the unit so that a broken antenna can be replaced by the user, but the use of a standard antenna jack or electrical connector is prohibited.

And according to § 15.247 (b) (4), if transmitting antennas of directional gain greater than 6 dBi are used the power shall be reduced by the amount in dB that the directional gain of the antenna exceeds 6 dBi.

### 4.2 Result

The antenna for this device is an internal panel antenna connected to the main board in a fashion not readily accessible to the end user with a maximum gain of 4.5 dBi which is under the 6 dBi limit.

**Compliant.** Please refer to the following antenna photo for details.

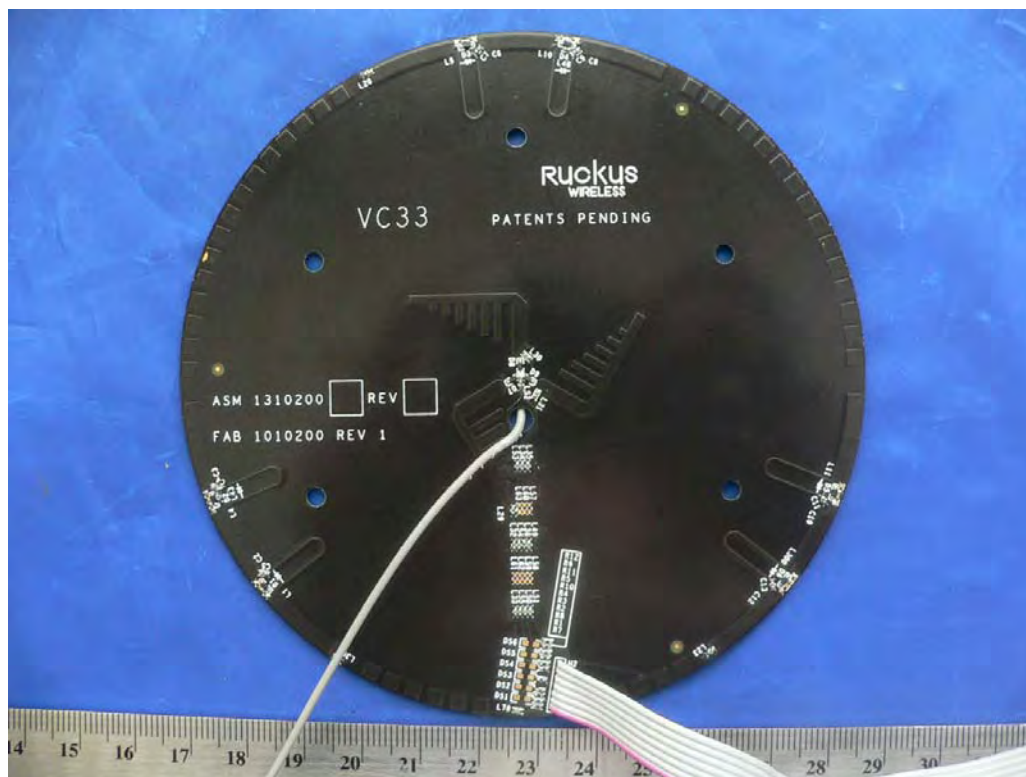

## 5 §1.1307(b) (1), §2.1091 - RF EXPOSURE

According to §15.247(e)(i) and §1.1307(b)(1), systems operating under the provisions of this section shall be operated in a manner that ensures that the public is not exposed to radio frequency energy level in excess of the Commission's guidelines.

According to §1.1310 and §2.1091 RF exposure is calculated.

### Limits for General Population/Uncontrolled Exposure

| Frequency Range (MHz)                               | Electric Field Strength (V/m) | Magnetic Field Strength (A/m) | Power Density (mW/cm <sup>2</sup> ) | Averaging Time (minute) |
|---|-------------------------------|-------------------------------|-------------------------------------|-------------------------|
| Limits for General Population/Uncontrolled Exposure |                               |                               |                                     |                         |
| 0.3-1.34  | 614                           | 1.63                          | *(100)                              | 30                      |
| 1.34-30   | 824/f                         | 2.19/f                        | *(180/f <sup>2</sup> )              | 30                      |
| 30-300  | 27.5                          | 0.073                         | 0.2                                 | 30                      |
| 300-1500  | /                             | /                             | f/1500                              | 30                      |
| 1500-100,000  | /                             | /                             | 1.0                                 | 30                      |

f = frequency in MHz

\* = Plane-wave equivalent power density

### MPE Prediction

Predication of MPE limit at a given distance

Equation from page 18 of OET Bulletin 65, Edition 97-01

$$S = PG/4\pi R^2$$

Where: S = power density

P = power input to antenna

G = power gain of the antenna in the direction of interest relative to an isotropic radiator

R = distance to the center of radiation of the antenna

Maximum peak output power at antenna input terminal: 23.0(dBm)

Maximum peak output power at antenna input terminal: 200.00 (mW)

Prediction distance: 20 (cm)

Predication frequency: 2400 (MHz)

Antenna Gain (typical): 4.5 (dBi)

antenna gain: 2.82(numeric)

Power density at predication frequency at 20 cm: 0.1122(mW/cm<sup>2</sup>)

MPE limit for uncontrolled exposure at prediction frequency: 1.0 (mW/cm<sup>2</sup>)

**Test Result**

The EUT is a mobile device. The power density level at 20 cm is 0.1122mW/cm<sup>2</sup>, which is below the uncontrolled exposure limit of 1.0mW/cm<sup>2</sup> at 2400 MHz.

## 6 §15.205 & §15.209 & §15.247(c) - SPURIOUS RADIATED EMISSION

### 6.1 Applicable Standard

As per 15.35(d): Unless otherwise specified, on any frequency or frequencies above 1000 MHz, the radiated emission limits are based on the use of measurement instrumentation employing an average detector function. Unless otherwise specified, measurements above 1000 MHz shall be performed using a minimum resolution bandwidth of 1 MHz.

As per 15.209(a): Except as provided elsewhere in this Subpart, the emissions from an intentional radiator shall not exceed the field strength levels specified in the following table

| Frequency (MHz) | Field Strength (micro volts/meter) | Measurement Distance (meters) |
|-----------------|------------------------------------|-------------------------------|
| 0.009 - 0.490   | 2400/F(kHz)                        | 300                           |
| 0.490 - 1.705   | 24000/F(kHz)                       | 30                            |
| 1.705 - 30.0    | 30                                 | 30                            |
| 30 - 88         | 100**                              | 3                             |
| 88 - 216        | 150**                              | 3                             |
| 216 - 960       | 200**                              | 3                             |
| Above 960       | 500                                | 3                             |

\*\* Except as provided in paragraph (g), fundamental emissions from intentional radiators operating under this Section shall not be located in the frequency bands 54-72 MHz, 76-88 MHz, 174-216 MHz or 470-806 MHz. However, operation within these frequency bands is permitted under other sections of this Part, e.g., Sections 15.231 and 15.241.

As Per 15.205(a) except as show in paragraph (d) of this section, only spurious emissions are permitted in any of the frequency bands listed below:

| MHz                 | MHz                   | MHz             | GHz           |
|---------------------|-----------------------|-----------------|---------------|
| 0.090 – 0.110       | 16.42 – 16.423        | 960 – 1240      | 4.5 – 5.15    |
| 0.495 – 0.505       | 16.69475 – 16.69525   | 1300 – 1427     | 5.35 – 5.46   |
| 2.1735 – 2.1905     | 25.5 – 25.67          | 1435 – 1626.5   | 7.25 – 7.75   |
| 4.125 – 4.128       | 37.5 – 38.25          | 1645.5 – 1646.5 | 8.025 – 8.5   |
| 4.17725 – 4.17775   | 73 – 74.6             | 1660 – 1710     | 9.0 – 9.2     |
| 4.20725 – 4.20775   | 74.8 – 75.2           | 1718.8 – 1722.2 | 9.3 – 9.5     |
| 6.215 – 6.218       | 108 – 121.94          | 2200 – 2300     | 10.6 – 12.7   |
| 6.26775 – 6.26825   | 123 – 138             | 2310 – 2390     | 13.25 – 13.4  |
| 6.31175 – 6.31225   | 149.9 – 150.05        | 2483.5 – 2500   | 14.47 – 14.5  |
| 8.291 – 8.294       | 156.52475 – 156.52525 | 2690 – 2900     | 15.35 – 16.2  |
| 8.362 – 8.366       | 156.7 – 156.9         | 3260 – 3267     | 17.7 – 21.4   |
| 8.37625 – 8.38675   | 162.0125 – 167.17     | 3.332 – 3.339   | 22.01 – 23.12 |
| 8.41425 – 8.41475   | 167.72 – 173.2        | 3.3458 – 3.358  | 23.6 – 24.0   |
| 12.29 – 12.293      | 240 – 285             | 3.600 – 4.400   | 31.2 – 31.8   |
| 12.51975 – 12.52025 | 322 – 335.4           |                 | 36.43 – 36.5  |
| 12.57675 – 12.57725 | 399.9 – 410           |                 | Above 38.6    |
| 13.36 – 13.41       | 608 – 614             |                 |               |

### 6.2 Test Setup

The radiated emissions tests were performed in the 3-meter open area test site, using the setup in accordance with ANSI C63.4-2003. The specification used was the FCC 15 Subpart C and E limits.

The spacing between the peripherals was 10 centimetres.

External I/O cables were draped along the edge of the test table and bundle when necessary.

### 6.3 Test Equipment List and Details

| Manufacturer  | Equipment Description         | Model     | Serial Number | Calibration Date |
|---------------|-------------------------------|-----------|---------------|------------------|
| Sonoma        | Amplifier, Pre                | 317       | 260407        | 2006-03-20       |
| Sunol Science | 30MHz ~ 2 GHz Antenna         | JB1       | A03105-3      | 2006-03-15       |
| A.R.A         | Antenna, Horn, DRG            | DRG-118/A | 1132          | 2005-08-17*      |
| Agilent       | Analyzer, Spectrum            | E4446A    | US44300386    | 2006-03-06       |
| HP            | Pre, Amplifier (1 ~ 26.5 GHz) | 8449B     | 3147A00400    | 2006-08-21       |

**Statement of Traceability:** BACL attests that all calibrations have been performed per the NVLAP requirements, traceable to NIST.

\* 2 year calibration cycle

### 6.4 Test Setup Block Diagram

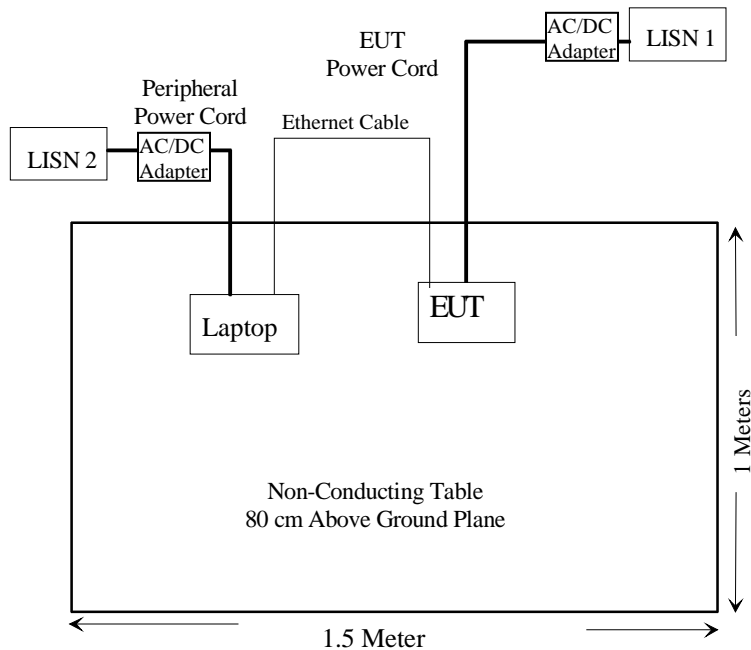

## 6.5 Test Procedure

For the radiated emissions test, the EUT, and all support equipment power cords was connected to the AC floor outlet.

Maximizing procedure was performed on the highest emissions to ensure that the EUT complied with all installation combinations.

The EUT is set 3 meter away from the testing antenna, which is varied from 1-4 mete, and the EUT is placed on a turntable, which is 0.8 meter above ground plane, the table shall be rotated for 360 degrees to find out the highest emission. The receiving antenna should be changed the polarization both of horizontal and vertical.

The spectrum analyzer or receiver is set as:

Below 1000MHz:

$$\text{RBW} = 100 \text{ kHz} / \text{VBW} = 300 \text{ kHz} / \text{Sweep} = \text{Auto}$$

Above 1000MHz:

$$(1) \text{ Peak: RBW} = 1\text{MHz} / \text{VBW} = 1\text{MHz} / \text{Sweep} = \text{Auto}$$

$$(2) \text{ Average: RBW} = 1\text{MHz} / \text{VBW} = 10\text{Hz} / \text{Sweep} = \text{Auto}$$

### Corrected Amplitude & Margin Calculation

The Corrected Amplitude is calculated by adding the Antenna Factor and Cable Factor, and subtracting the Amplifier Gain from the Amplitude reading. The basic equation is as follows:

$$\text{Corrected Amplitude} = \text{Indicated Reading} + \text{Antenna Factor} + \text{Cable Factor} - \text{Amplifier Gain}$$

The “**Margin**” column of the following data tables indicates the degree of compliance with the applicable limit. For example, a margin of -7dB means the emission is 7dB below the maximum limit.

The equation for margin calculation is as follows:

$$\text{Margin} = \text{Corrected Amplitude} - \text{FCC Limit}$$

#### 6.5.1 Environmental Conditions

|                    |           |
|--------------------|-----------|
| Temperature:       | 20 ° C    |
| Relative Humidity: | 55 %      |
| ATM Pressure:      | 1013 mbar |

*The testing was performed by Oscar Au on 2007-01-09.*

## 6.6 Summary of Test Results

According to the data hereinafter, the EUT complied with the FCC Title 47, Part 15 section 15.205, 15.209 and Subpart C 15.247 standard's limits, and had the worst margin of:

802.11b:

- 1.7 dB at 9648.00 MHz in the **Horizontal** polarization, Low Channel
- 11.9 dB at 9748.00 MHz in the **Horizontal** polarization, Middle Channel
- 10.3 dB at 4924.00 MHz in the **Vertical** polarization, High Channel

802.11g:

- 11.1 dB at 9648.00 MHz in the **Horizontal** polarization, Low Channel
- 15.2 dB at 4874.00 MHz in the **Vertical** polarization, Middle Channel
- 12.2 dB at 4924.00 MHz in the **Vertical** polarization, High Channel

*.Please refer to the following table and plots for specific test result details*

## Run # 1 Radiated Harmonic and Spurious Emission 802.11b (Antenna 4.5 dBi)

**Run # 1- 1 : Final scan 1GHz -25GHz, ( Lowest channel. : 2412 MHz)**

| Frequency (MHz) | Reading (dBµV) | Azimuth (Degree) | Height (Meter) | Polar. (H / V) | Antenna Factor (dB/m) | Cable loss (dB) | Amplifier (dB) | Distance factor (dB) | Corrected Reading (dBµV/m) | 15.247 Limit (dBµV/m) | 15.247 Margin | Comments  |
|-----------------|----------------|------------------|----------------|----------------|-----------------------|-----------------|----------------|----------------------|----------------------------|-----------------------|---------------|-----------|
| 2412.0000       | 112.3          | 310              | 1.8            | V              | 28.7                  | 2.7             | 35.8           | 0.0                  | 107.8                      |                       |               | Fund/Peak |
| 2412.0000       | 116.8          | 180              | 1.4            | H              | 28.7                  | 2.7             | 35.8           | 0.0                  | 112.3                      |                       |               | Fund/Peak |
| 2412.0000       | 76.2           | 310              | 1.8            | V              | 28.7                  | 2.7             | 35.8           | 0.0                  | 71.7                       |                       |               | Ave       |
| 2412.0000       | 83.3           | 170              | 1.4            | H              | 28.7                  | 2.7             | 35.8           | 0.0                  | 78.8                       |                       |               | Ave       |
| 9648.0000       | 45.6           | 60               | 1.3            | H              | 38.1                  | 5.5             | 36.9           | 0.0                  | 52.3                       | 54                    | -1.7          | Ave       |
| 7236.0000       | 41.7           | 210              | 1.5            | H              | 36.7                  | 4.8             | 34.9           | 0.0                  | 48.3                       | 54                    | -5.7          | Ave       |
| 4824.0000       | 46.7           | 40               | 1.6            | V              | 32.5                  | 3.8             | 34.8           | 0.0                  | 48.2                       | 54                    | -5.8          | Ave       |
| 7236.0000       | 41.3           | 210              | 1.8            | V              | 36.7                  | 4.8             | 34.9           | 0.0                  | 47.9                       | 54                    | -6.1          | Ave       |
| 9648.0000       | 40.7           | 260              | 1.9            | V              | 38.1                  | 5.5             | 36.9           | 0.0                  | 47.4                       | 54                    | -6.6          | Ave       |
| 4824.0000       | 44.1           | 160              | 1.5            | H              | 32.5                  | 3.8             | 34.8           | 0.0                  | 45.6                       | 54                    | -8.4          | Ave       |
| 4824.0000       | 63.9           | 40               | 1.6            | V              | 32.5                  | 3.8             | 34.8           | 0.0                  | 65.4                       | 74                    | -8.6          | Peak      |
| 9648.0000       | 58.6           | 60               | 1.3            | H              | 38.1                  | 5.5             | 36.9           | 0.0                  | 65.3                       | 74                    | -8.7          | Peak      |
| 7236.0000       | 54.9           | 210              | 1.8            | V              | 36.7                  | 4.8             | 34.9           | 0.0                  | 61.5                       | 74                    | -12.5         | Peak      |
| 4824.0000       | 59.6           | 160              | 1.5            | H              | 32.5                  | 3.8             | 34.8           | 0.0                  | 61.1                       | 74                    | -12.9         | Peak      |
| 7236.0000       | 54.4           | 210              | 1.5            | H              | 36.7                  | 4.8             | 34.9           | 0.0                  | 61.0                       | 74                    | -13.0         | Peak      |
| 9648.0000       | 53.6           | 260              | 1.9            | V              | 38.1                  | 5.5             | 36.9           | 0.0                  | 60.3                       | 74                    | -13.7         | Peak      |

**Run # 1- 2 : Final scan 1GHz -25GHz, ( Middle channel. : 2437 MHz)**

| Frequency (MHz) | Reading (dBµV) | Azimuth (Degree) | Height (Meter) | Polar. (H / V) | Antenna Factor (dB/m) | Cable loss (dB) | Amplifier (dB) | Distance factor (dB) | Corrected Reading (dBµV/m) | 15.247 Limit (dBµV/m) | 15.247 Margin | Comments  |
|-----------------|----------------|------------------|----------------|----------------|-----------------------|-----------------|----------------|----------------------|----------------------------|-----------------------|---------------|-----------|
| 2437.0000       | 102.2          | 325              | 2.0            | V              | 28.7                  | 2.7             | 35.8           | 0.0                  | 97.7                       |                       |               | Fund/Peak |
| 2437.0000       | 115.9          | 70               | 1.6            | H              | 28.7                  | 2.7             | 35.8           | 0.0                  | 111.4                      |                       |               | Fund/Peak |
| 2437.0000       | 66.4           | 325              | 2.0            | V              | 28.7                  | 2.7             | 35.8           | 0.0                  | 61.9                       |                       |               | Ave       |
| 2437.0000       | 83.2           | 70               | 1.6            | H              | 28.7                  | 2.7             | 35.8           | 0.0                  | 78.7                       |                       |               | Ave       |
| 9748.0000       | 35.0           | 65               | 1.3            | H              | 38.1                  | 5.6             | 36.7           | 0.0                  | 42.1                       | 54                    | -11.9         | Ave       |
| 4874.0000       | 37.9           | 40               | 1.8            | V              | 32.5                  | 3.8             | 34.8           | 0.0                  | 39.4                       | 54                    | -14.6         | Ave       |
| 9748.0000       | 32.0           | 30               | 1.6            | V              | 38.1                  | 5.6             | 36.7           | 0.0                  | 39.1                       | 54                    | -14.9         | Ave       |
| 4874.0000       | 57.1           | 40               | 1.8            | V              | 32.5                  | 3.8             | 34.8           | 0.0                  | 58.6                       | 74                    | -15.4         | Peak      |
| 7311.0000       | 32.1           | 240              | 1.8            | V              | 36.7                  | 4.8             | 35.1           | 0.0                  | 38.5                       | 54                    | -15.5         | Ave       |
| 7311.0000       | 32.1           | 275              | 1.5            | H              | 36.7                  | 4.8             | 35.1           | 0.0                  | 38.5                       | 54                    | -15.5         | Ave       |
| 4874.0000       | 36.3           | 160              | 1.4            | H              | 32.5                  | 3.8             | 34.8           | 0.0                  | 37.8                       | 54                    | -16.2         | Ave       |
| 4874.0000       | 53.8           | 160              | 1.4            | H              | 32.5                  | 3.8             | 34.8           | 0.0                  | 55.3                       | 74                    | -18.7         | Peak      |
| 7311.0000       | 45.5           | 240              | 1.8            | V              | 36.7                  | 4.8             | 35.1           | 0.0                  | 51.9                       | 74                    | -22.1         | Peak      |
| 7311.0000       | 45.4           | 275              | 1.5            | H              | 36.7                  | 4.8             | 35.1           | 0.0                  | 51.8                       | 74                    | -22.2         | Peak      |
| 9748.0000       | 44.6           | 30               | 1.6            | V              | 38.1                  | 5.6             | 36.7           | 0.0                  | 51.7                       | 74                    | -22.3         | Peak      |
| 9748.0000       | 44.5           | 65               | 1.3            | H              | 38.1                  | 5.6             | 36.7           | 0.0                  | 51.6                       | 74                    | -22.4         | Peak      |



***Run # 1- 3 :Final scan 1GHz -25GHz, ( Highest channel. : 2462 MHz)***

| Frequency (MHz) | Reading (dBμV) | Azimuth (Degree) | Height (Meter) | Polar. (H / V) | Antenna Factor (dB/m) | Cable loss (dB) | Amplifier (dB) | Distance factor (dB) | Corrected Reading (dBμV/m) | 15.247 Limit (dBμV/m) | 15.247 Margin | Comments  |
|-----------------|----------------|------------------|----------------|----------------|-----------------------|-----------------|----------------|----------------------|----------------------------|-----------------------|---------------|-----------|
| 2462.0000       | 113.0          | 320              | 2.0            | V              | 28.7                  | 2.7             | 35.8           | 0.0                  | 108.5                      |                       |               | Fund/Peak |
| 2462.0000       | 116.0          | 175              | 1.9            | H              | 28.7                  | 2.7             | 35.8           | 0.0                  | 111.5                      |                       |               | Fund/Peak |
| 2462.0000       | 76.8           | 320              | 2.0            | V              | 28.7                  | 2.7             | 35.8           | 0.0                  | 72.3                       |                       |               | Ave       |
| 2462.0000       | 83.3           | 175              | 1.9            | H              | 28.7                  | 2.7             | 35.8           | 0.0                  | 78.8                       |                       |               | Ave       |
| 4924.0000       | 62.3           | 10               | 1.8            | V              | 32.5                  | 3.9             | 35.0           | 0.0                  | 63.7                       | 74                    | -10.3         | Peak      |
| 4924.0000       | 42.2           | 10               | 1.8            | V              | 32.5                  | 3.9             | 35.0           | 0.0                  | 43.6                       | 54                    | -10.4         | Ave       |
| 4924.0000       | 41.0           | 160              | 1.4            | H              | 32.5                  | 3.9             | 35.0           | 0.0                  | 42.4                       | 54                    | -11.6         | Ave       |
| 4924.0000       | 58.8           | 160              | 1.4            | H              | 32.5                  | 3.9             | 35.0           | 0.0                  | 60.2                       | 74                    | -13.8         | Peak      |
| 9848.0000       | 32.4           | 240              | 1.6            | H              | 38.1                  | 5.6             | 37.0           | 0.0                  | 39.1                       | 54                    | -14.9         | Ave       |
| 7386.0000       | 32.5           | 290              | 1.4            | H              | 36.7                  | 4.8             | 35.1           | 0.0                  | 38.9                       | 54                    | -15.1         | Ave       |
| 9848.0000       | 32.2           | 250              | 1.8            | V              | 38.1                  | 5.6             | 37.0           | 0.0                  | 38.9                       | 54                    | -15.1         | Ave       |
| 7386.0000       | 31.8           | 200              | 1.9            | V              | 36.7                  | 4.8             | 35.1           | 0.0                  | 38.2                       | 54                    | -15.8         | Ave       |
| 7386.0000       | 45.7           | 290              | 1.4            | H              | 36.7                  | 4.8             | 35.1           | 0.0                  | 52.1                       | 74                    | -21.9         | Peak      |
| 7386.0000       | 45.1           | 200              | 1.9            | V              | 36.7                  | 4.8             | 35.1           | 0.0                  | 51.5                       | 74                    | -22.5         | Peak      |
| 9848.0000       | 44.8           | 240              | 1.6            | H              | 38.1                  | 5.6             | 37.0           | 0.0                  | 51.5                       | 74                    | -22.5         | Peak      |
| 9848.0000       | 44.3           | 250              | 1.8            | V              | 38.1                  | 5.6             | 37.0           | 0.0                  | 51.0                       | 74                    | -23.0         | Peak      |

## Run # 1 Radiated Harmonic and Spurious Emission 802.11g (Antenna 4.5 dBi)

Run # 1- 1 : Final scan 1GHz -25GHz, ( Lowest channel. : 2412 MHz)

| Frequency (MHz) | Reading (dBµV) | Azimuth (Degree) | Height (Meter) | Polar. (H / V) | Antenna Factor (dB/m) | Cable loss (dB) | Amplifier (dB) | Distance factor (dB) | Corrected Reading (dBµV/m) | 15.247 Limit (dBµV/m) | 15.247 Margin | Comments  |
|-----------------|----------------|------------------|----------------|----------------|-----------------------|-----------------|----------------|----------------------|----------------------------|-----------------------|---------------|-----------|
| 2412.0000       | 104.1          | 43               | 1.8            | V              | 28.7                  | 2.7             | 35.8           | 0.0                  | 99.6                       |                       |               | Fund/Peak |
| 2412.0000       | 120.4          | 285              | 1.9            | H              | 28.7                  | 2.7             | 35.8           | 0.0                  | 115.9                      |                       |               | Fund/Peak |
| 2412.0000       | 61.3           | 43               | 1.8            | V              | 28.7                  | 2.7             | 35.8           | 0.0                  | 56.8                       |                       |               | Ave       |
| 2412.0000       | 62.6           | 285              | 1.9            | H              | 28.7                  | 2.7             | 35.8           | 0.0                  | 58.1                       |                       |               | Ave       |
| 9648.0000       | 56.2           | 55               | 1.4            | H              | 38.1                  | 5.5             | 36.9           | 0.0                  | 62.9                       | 74                    | -11.1         | Peak      |
| 7236.0000       | 50.5           | 300              | 1.4            | H              | 36.7                  | 4.8             | 34.9           | 0.0                  | 57.1                       | 74                    | -16.9         | Peak      |
| 7236.0000       | 30.3           | 300              | 1.4            | H              | 36.7                  | 4.8             | 34.9           | 0.0                  | 36.9                       | 54                    | -17.1         | Ave       |
| 7236.0000       | 29.4           | 200              | 1.5            | V              | 36.7                  | 4.8             | 34.9           | 0.0                  | 36.0                       | 54                    | -18.0         | Ave       |
| 9648.0000       | 29.3           | 55               | 1.4            | H              | 38.1                  | 5.5             | 36.9           | 0.0                  | 36.0                       | 54                    | -18.0         | Ave       |
| 9648.0000       | 28.7           | 240              | 1.7            | V              | 38.1                  | 5.5             | 36.9           | 0.0                  | 35.4                       | 54                    | -18.6         | Ave       |
| 4824.0000       | 52.8           | 50               | 1.0            | V              | 32.5                  | 3.8             | 34.8           | 0.0                  | 54.3                       | 74                    | -19.7         | Peak      |
| 9648.0000       | 46.8           | 240              | 1.7            | V              | 38.1                  | 5.5             | 36.9           | 0.0                  | 53.5                       | 74                    | -20.5         | Peak      |
| 7236.0000       | 46.3           | 200              | 1.5            | V              | 36.7                  | 4.8             | 34.9           | 0.0                  | 52.9                       | 74                    | -21.1         | Peak      |
| 4824.0000       | 48.9           | 160              | 1.3            | H              | 32.5                  | 3.8             | 34.8           | 0.0                  | 50.4                       | 74                    | -23.6         | Peak      |
| 4824.0000       | 24.8           | 160              | 1.3            | H              | 32.5                  | 3.8             | 34.8           | 0.0                  | 26.3                       | 54                    | -27.7         | Ave       |
| 4824.0000       | 24.5           | 50               | 1.0            | V              | 32.5                  | 3.8             | 34.8           | 0.0                  | 26.0                       | 54                    | -28.0         | Ave       |

Run # 1- 2 : Final scan 1GHz -25GHz, ( Middle channel. : 2437 MHz)

| Frequency (MHz) | Reading (dBµV) | Azimuth (Degree) | Height (Meter) | Polar. (H / V) | Antenna Factor (dB/m) | Cable loss (dB) | Amplifier (dB) | Distance factor (dB) | Corrected Reading (dBµV/m) | 15.247 Limit (dBµV/m) | 15.247 Margin | Comments  |
|-----------------|----------------|------------------|----------------|----------------|-----------------------|-----------------|----------------|----------------------|----------------------------|-----------------------|---------------|-----------|
| 2437.0000       | 102.4          | 140              | 2.0            | V              | 28.7                  | 2.7             | 35.8           | 0.0                  | 97.9                       |                       |               | Fund/Peak |
| 2437.0000       | 118.4          | 75               | 2.1            | H              | 28.7                  | 2.7             | 35.8           | 0.0                  | 113.9                      |                       |               | Fund/Peak |
| 2437.0000       | 61.2           | 140              | 2.0            | V              | 28.7                  | 2.7             | 35.8           | 0.0                  | 56.7                       |                       |               | Ave       |
| 2437.0000       | 62.5           | 75               | 2.1            | H              | 28.7                  | 2.7             | 35.8           | 0.0                  | 58.0                       |                       |               | Ave       |
| 4874.0000       | 57.3           | 22               | 1.7            | V              | 32.5                  | 3.8             | 34.8           | 0.0                  | 58.8                       | 74                    | -15.2         | Peak      |
| 9748.0000       | 28.7           | 180              | 1.7            | H              | 38.1                  | 5.6             | 36.7           | 0.0                  | 35.8                       | 54                    | -18.2         | Ave       |
| 7311.0000       | 28.9           | 200              | 1.5            | V              | 36.7                  | 4.8             | 35.1           | 0.0                  | 35.3                       | 54                    | -18.7         | Ave       |
| 9748.0000       | 28.2           | 20               | 1.6            | V              | 38.1                  | 5.6             | 36.7           | 0.0                  | 35.3                       | 54                    | -18.7         | Ave       |
| 7311.0000       | 28.7           | 340              | 1.4            | H              | 36.7                  | 4.8             | 35.1           | 0.0                  | 35.1                       | 54                    | -18.9         | Ave       |
| 9748.0000       | 46.2           | 180              | 1.7            | H              | 38.1                  | 5.6             | 36.7           | 0.0                  | 53.3                       | 74                    | -20.7         | Peak      |
| 7311.0000       | 46.8           | 200              | 1.5            | V              | 36.7                  | 4.8             | 35.1           | 0.0                  | 53.2                       | 74                    | -20.8         | Peak      |
| 4874.0000       | 50.8           | 160              | 1.8            | H              | 32.5                  | 3.8             | 34.8           | 0.0                  | 52.3                       | 74                    | -21.7         | Peak      |
| 9748.0000       | 45.1           | 20               | 1.6            | V              | 38.1                  | 5.6             | 36.7           | 0.0                  | 52.2                       | 74                    | -21.8         | Peak      |
| 7311.0000       | 45.7           | 340              | 1.4            | H              | 36.7                  | 4.8             | 35.1           | 0.0                  | 52.1                       | 74                    | -21.9         | Peak      |
| 4874.0000       | 26.0           | 22               | 1.7            | V              | 32.5                  | 3.8             | 34.8           | 0.0                  | 27.5                       | 54                    | -26.5         | Ave       |
| 4874.0000       | 25.4           | 160              | 1.8            | H              | 32.5                  | 3.8             | 34.8           | 0.0                  | 26.9                       | 54                    | -27.1         | Ave       |

***Run # 1- 3 :Final scan 1GHz -25GHz, ( Highest channel. : 2462 MHz)***

| Frequency (MHz) | Reading (dBµV) | Azimuth (Degree) | Height (Meter) | Polar. (H / V) | Antenna Factor (dB/m) | Cable loss (dB) | Amplifier (dB) | Distance factor (dB) | Corrected Reading (dBµV/m) | 15.247 Limit (dBµV/m) | 15.247 Margin | Comments  |
|-----------------|----------------|------------------|----------------|----------------|-----------------------|-----------------|----------------|----------------------|----------------------------|-----------------------|---------------|-----------|
| 2462.0000       | 105.5          | 40               | 2.0            | V              | 28.7                  | 2.7             | 35.8           | 0.0                  | 101.0                      |                       |               | Fund/Peak |
| 2462.0000       | 119.0          | 180              | 2.0            | H              | 28.7                  | 2.7             | 35.8           | 0.0                  | 114.5                      |                       |               | Fund/Peak |
| 2462.0000       | 61.4           | 40               | 2.0            | V              | 28.7                  | 2.7             | 35.8           | 0.0                  | 56.9                       |                       |               | Ave       |
| 2462.0000       | 62.5           | 180              | 2.0            | H              | 28.7                  | 2.7             | 35.8           | 0.0                  | 58.0                       |                       |               | Ave       |
| 4924.0000       | 60.4           | 20               | 2.0            | V              | 32.5                  | 3.9             | 35.0           | 0.0                  | 61.8                       | 74                    | -12.2         | Peak      |
| 9848.0000       | 28.5           | 200              | 1.8            | H              | 38.1                  | 5.6             | 37.0           | 0.0                  | 35.2                       | 54                    | -18.8         | Ave       |
| 9848.0000       | 28.4           | 240              | 1.8            | V              | 38.1                  | 5.6             | 37.0           | 0.0                  | 35.1                       | 54                    | -18.9         | Ave       |
| 4924.0000       | 53.6           | 170              | 2.0            | H              | 32.5                  | 3.9             | 35.0           | 0.0                  | 55.0                       | 74                    | -19.0         | Peak      |
| 7386.0000       | 28.5           | 200              | 1.8            | V              | 36.7                  | 4.8             | 35.1           | 0.0                  | 34.9                       | 54                    | -19.1         | Ave       |
| 7386.0000       | 28.2           | 220              | 2.2            | H              | 36.7                  | 4.8             | 35.1           | 0.0                  | 34.6                       | 54                    | -19.4         | Ave       |
| 7386.0000       | 47.6           | 200              | 1.8            | V              | 36.7                  | 4.8             | 35.1           | 0.0                  | 54.0                       | 74                    | -20.0         | Peak      |
| 9848.0000       | 45.0           | 200              | 1.8            | H              | 38.1                  | 5.6             | 37.0           | 0.0                  | 51.7                       | 74                    | -22.3         | Peak      |
| 4924.0000       | 30.2           | 20               | 2.0            | V              | 32.5                  | 3.9             | 35.0           | 0.0                  | 31.6                       | 54                    | -22.4         | Ave       |
| 4924.0000       | 29.8           | 170              | 2.0            | H              | 32.5                  | 3.9             | 35.0           | 0.0                  | 31.2                       | 54                    | -22.8         | Ave       |
| 7386.0000       | 44.1           | 220              | 2.2            | H              | 36.7                  | 4.8             | 35.1           | 0.0                  | 50.5                       | 74                    | -23.5         | Peak      |
| 9848.0000       | 42.6           | 240              | 1.8            | V              | 38.1                  | 5.6             | 37.0           | 0.0                  | 49.3                       | 74                    | -24.7         | Peak      |

## 7 EXHIBIT A - FCC ID LABEL INFORMATION

### 7.1 FCC § 2.925 Identification of equipment

(a) Each equipment covered in an application for equipment authorization shall bear a nameplate or label listing the following:

(1) FCC Identifier consisting of the two elements in the exact order specified in §2.926. The FCC Identifier shall be preceded by the term *FCC ID* in capital letters on a single line, and shall be of a type size large enough to be legible without the aid of magnification.

*Example:* FCC ID XXX123. XXX—Grantee Code 123—Equipment Product Code

### 7.2 ID Label Requirements as per FCC § 15.19

(a) In addition to the requirements in part 2 of this chapter, a device subject to certification, or verification shall be labeled as follows:

(3) All other devices shall bear the following statement in a conspicuous location on the device:

This device complies with part 15 of the FCC Rules. Operation is subject to the following two conditions: (1) This device may not cause harmful interference, and (2) this device must accept any interference received, including interference that may cause undesired operation.

(5) When the device is so small or for such use that it is not practicable to place the statement specified under paragraph (a) of this section on it, the information required by this paragraph shall be placed in a prominent location in the instruction manual or pamphlet supplied to the user or, alternatively, shall be placed on the container in which the device is marketed. However, the FCC identifier or the unique identifier, as appropriate, must be displayed on the device.

### 7.3 Proposed FCC ID Label

**Model: ZX2XX1**

This device complies with part 15 of the FCC Rules. Operation is subject to the following two conditions: (1) This device may not cause harmful interference, and (2) this device must accept any interference received, including interference that may cause undesired operation.

**FCC ID: S9GVX2XX1 Ruckus Wireless Corporation****IC:**

#### 7.4 Proposed Label on EUT (Bottom View)



As per FCC §15.17 (b) (4), the label shall not be a stick-on, paper label. The label on these products shall be permanently affixed to the product and shall be readily visible to the purchaser at the time of purchase, as described in Section 2.925(d) of this chapter. "Permanently affixed" means that the label is etched, engraved, stamped, silk-screened, indelibly printed, or otherwise permanently marked on a permanently attached part of the equipment or on a nameplate of metal, plastic, or other material fastened to the equipment by welding, riveting, or a permanent adhesive. The label must be designed to last the expected lifetime of the equipment in the environment in which the equipment may be operated and must not be readily detachable.

## 8 EXHIBIT B - TEST SETUP PHOTOGRAPHS

### 8.1 Radiated Emission – Front View



### 8.2 Radiated Emission – Rear View

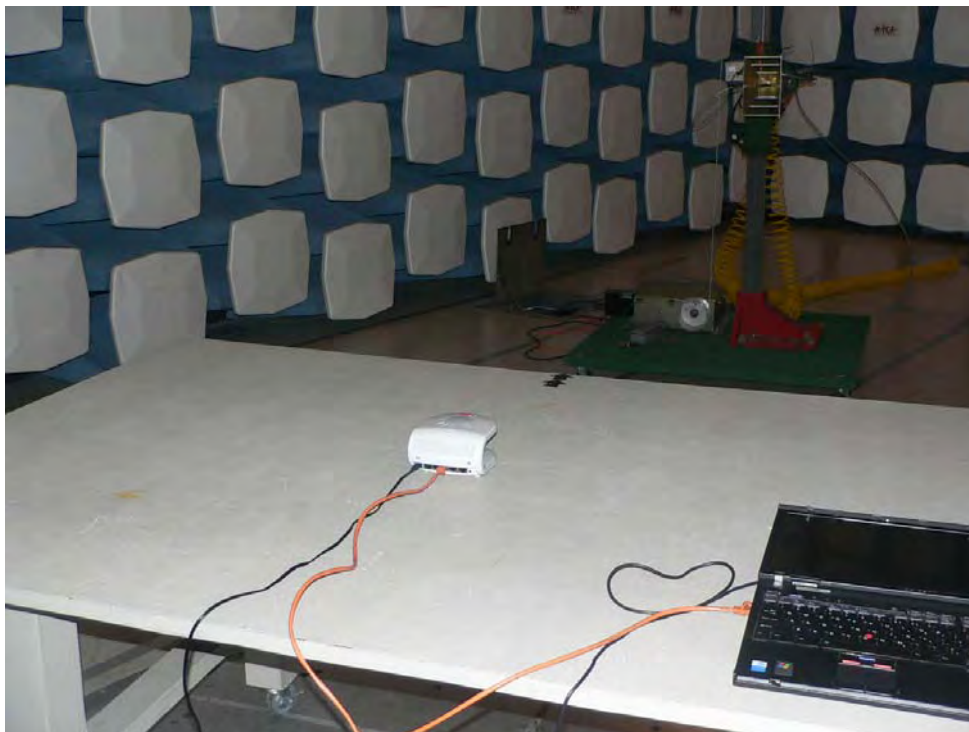

## 9 EXHIBIT C - EUT PHOTOGRAPHS

### 9.1 EUT – Top View



### 9.2 EUT – Bottom View



### 9.3 EUT – Cover Off View

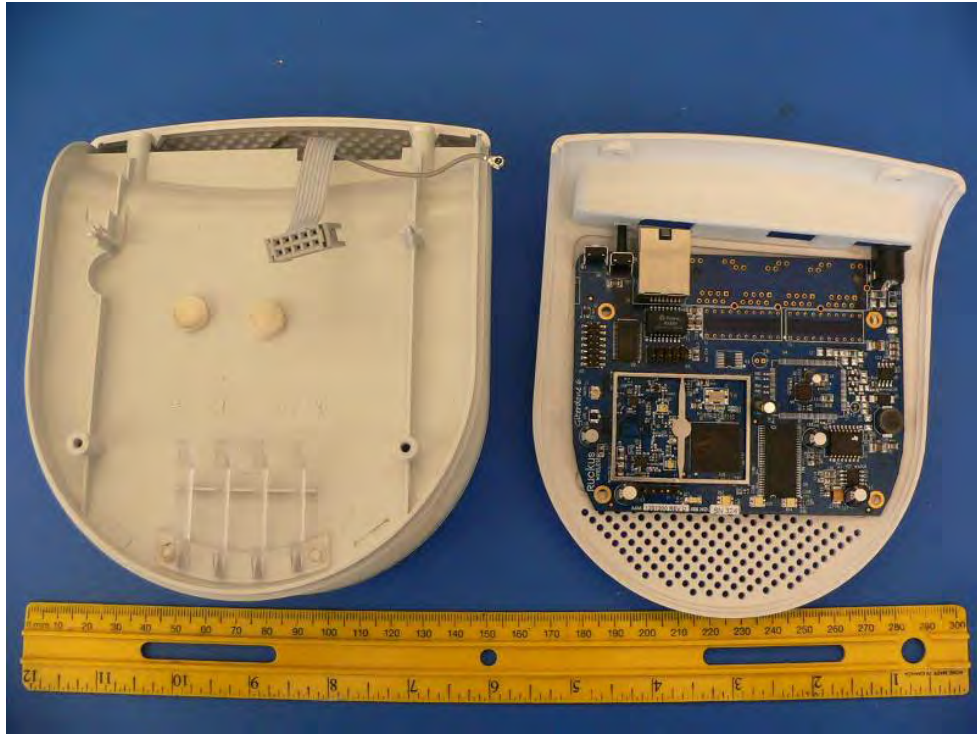

### 9.4 EUT – Main Board Component View

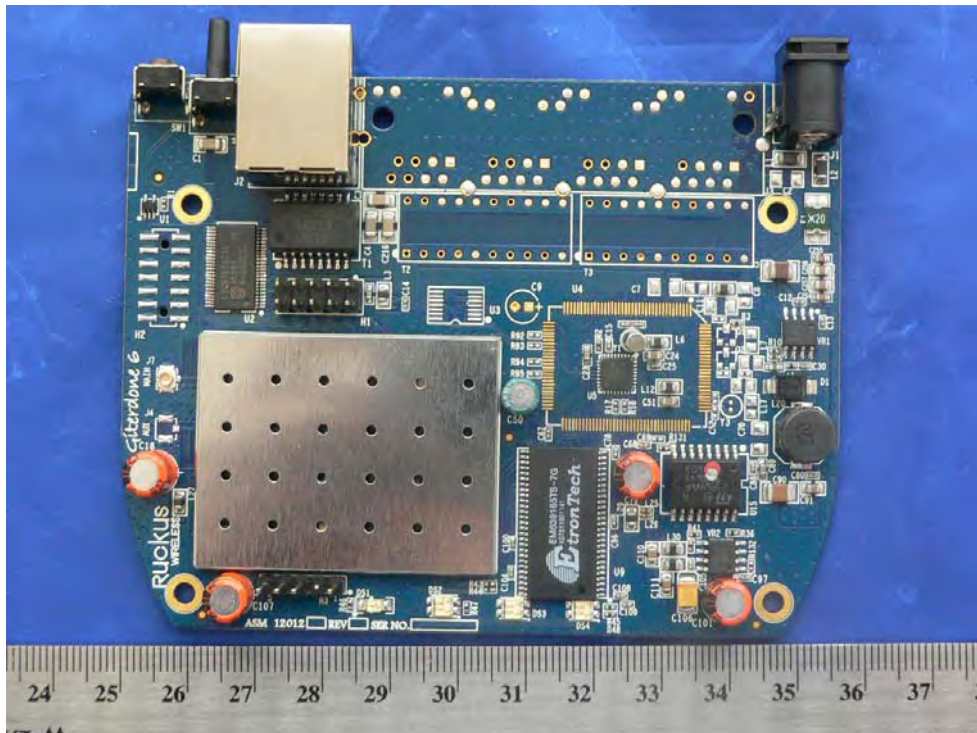



### 9.5 EUT – Main Board Solder View

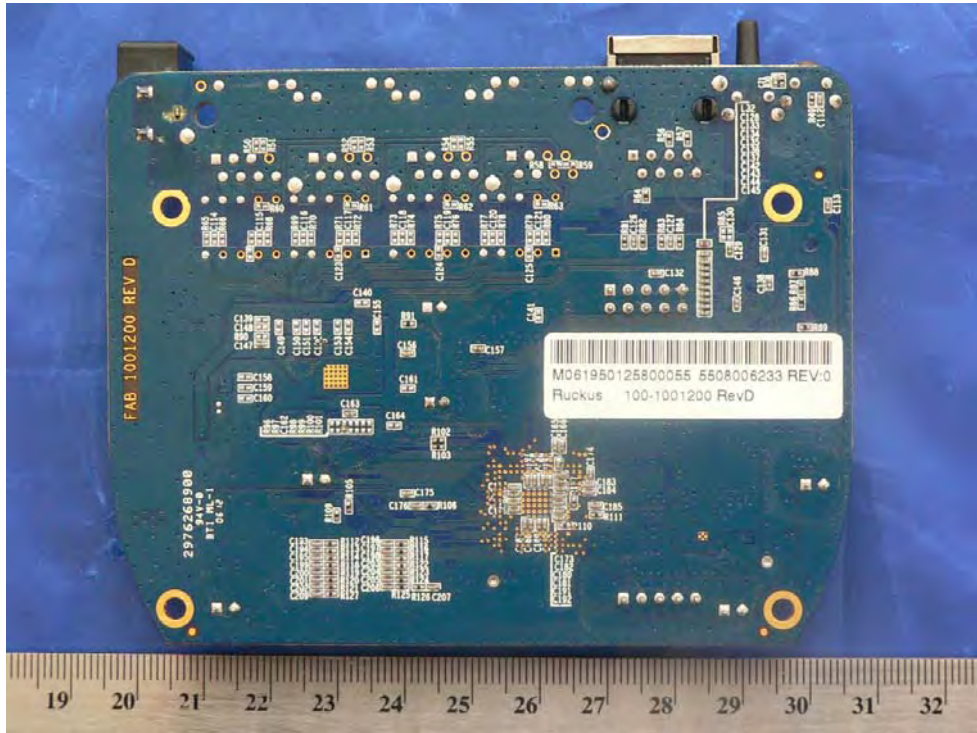

### 9.6 EUT – TX Close Up

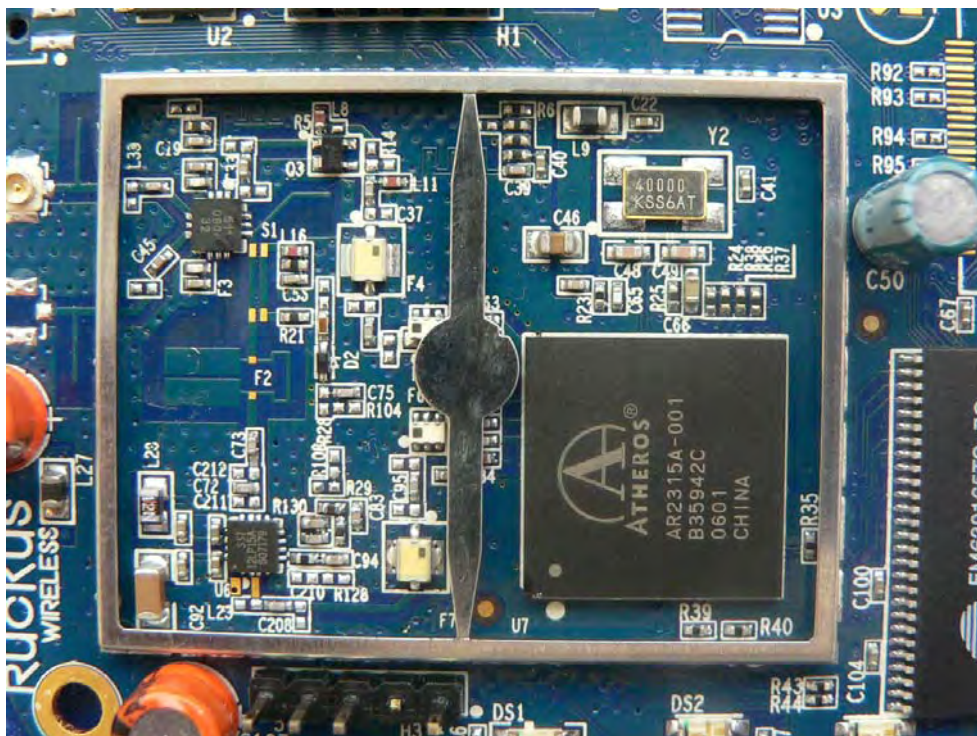

**9.7 EUT – Antenna View 1**

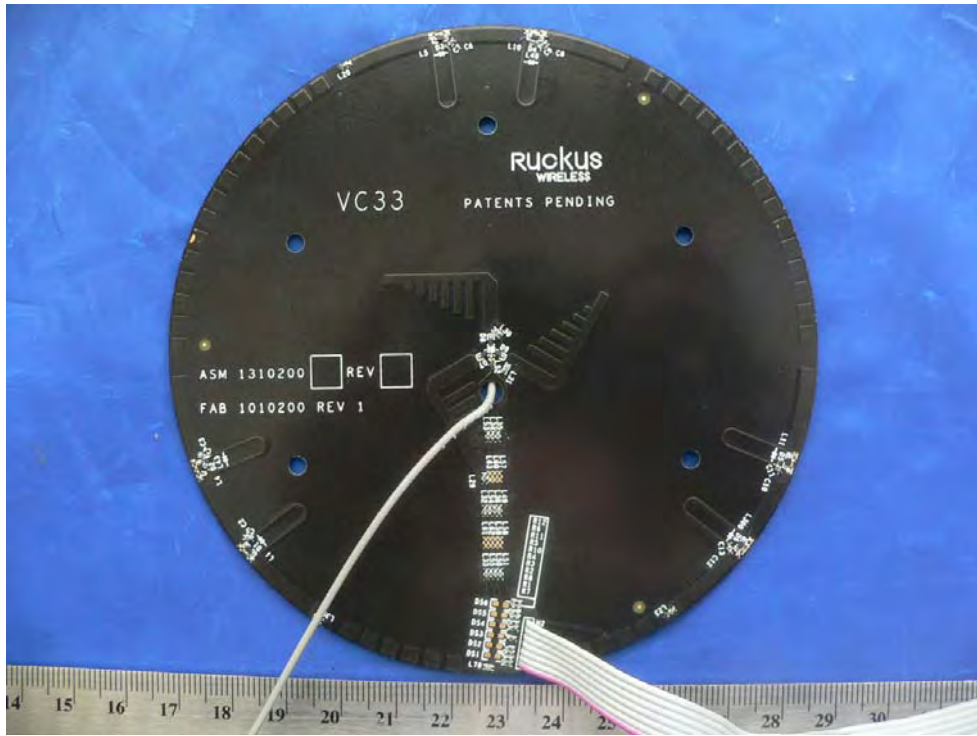

**9.8 EUT – Antenna View 2**

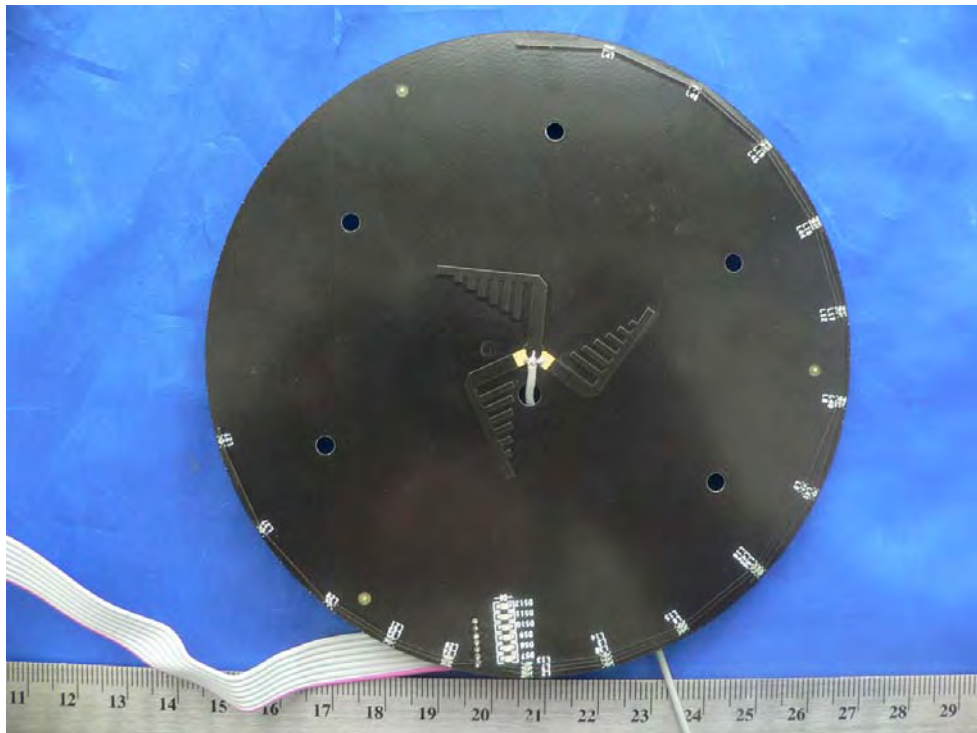

### 9.9 EUT – Port View

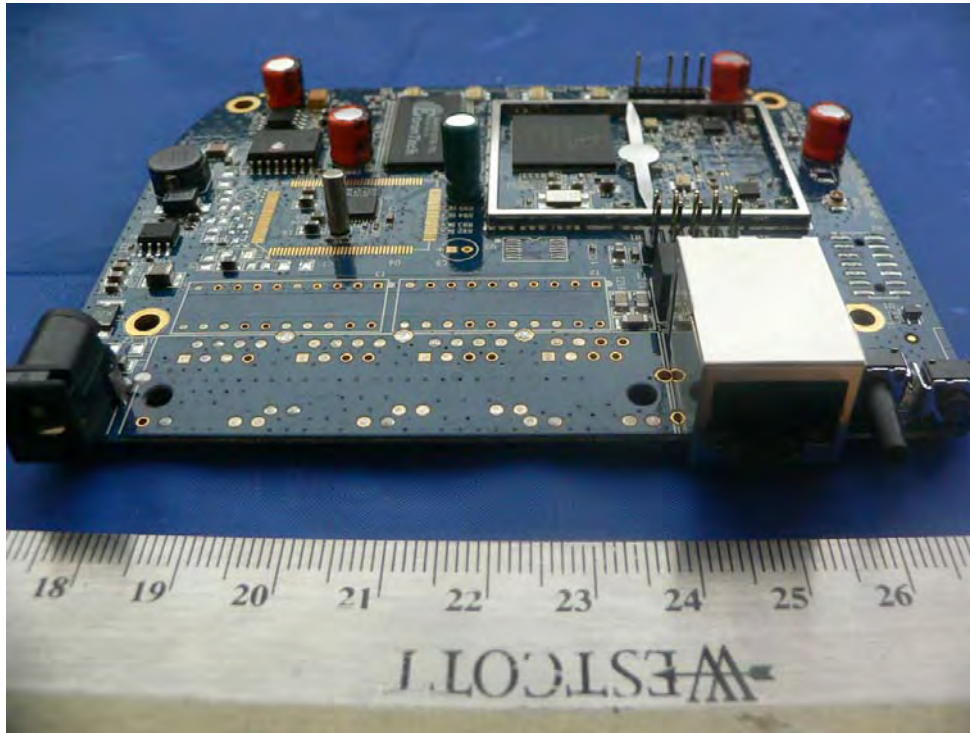

### 9.10 Power Supply Type 1-1 (Front)



### 9.11 Power Supply Type 1-1 (Rear)



### 9.12 Power Supply Type 1-2 (Front)



**9.13 Power Supply Type 1-2 (Rear)**

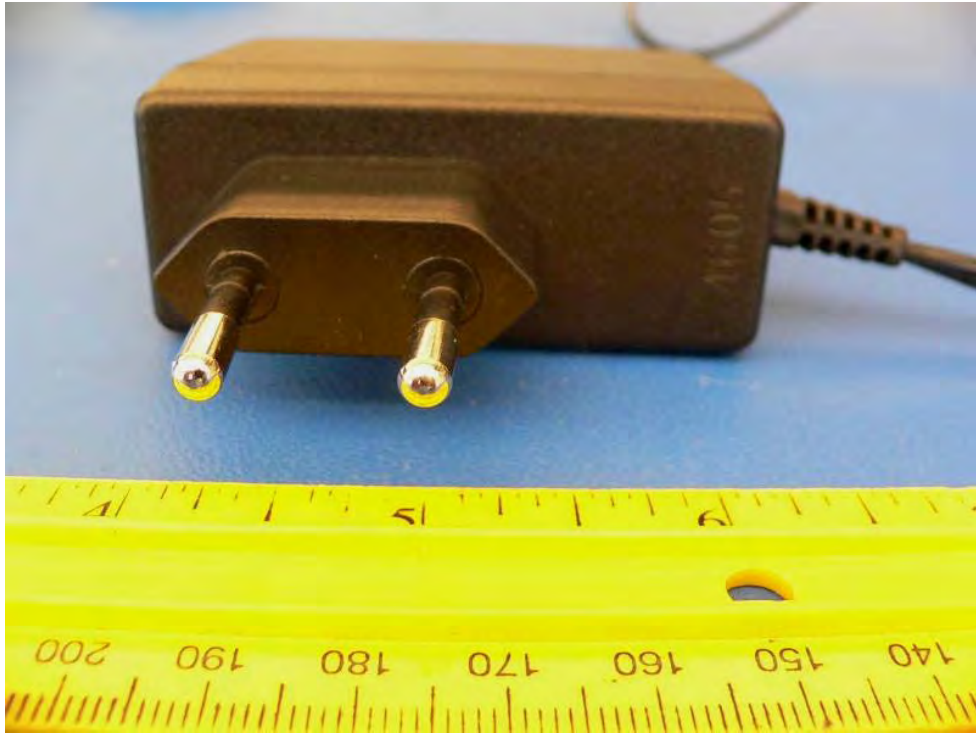

**9.14 Power Supply Type 1-3 (Front)**



**9.15 Power Supply Type 1-3 (Rear)**



**9.16 Power Supply Type 2-1 (Front)**



**9.17 Power Supply Type 2-1 (Rear)**

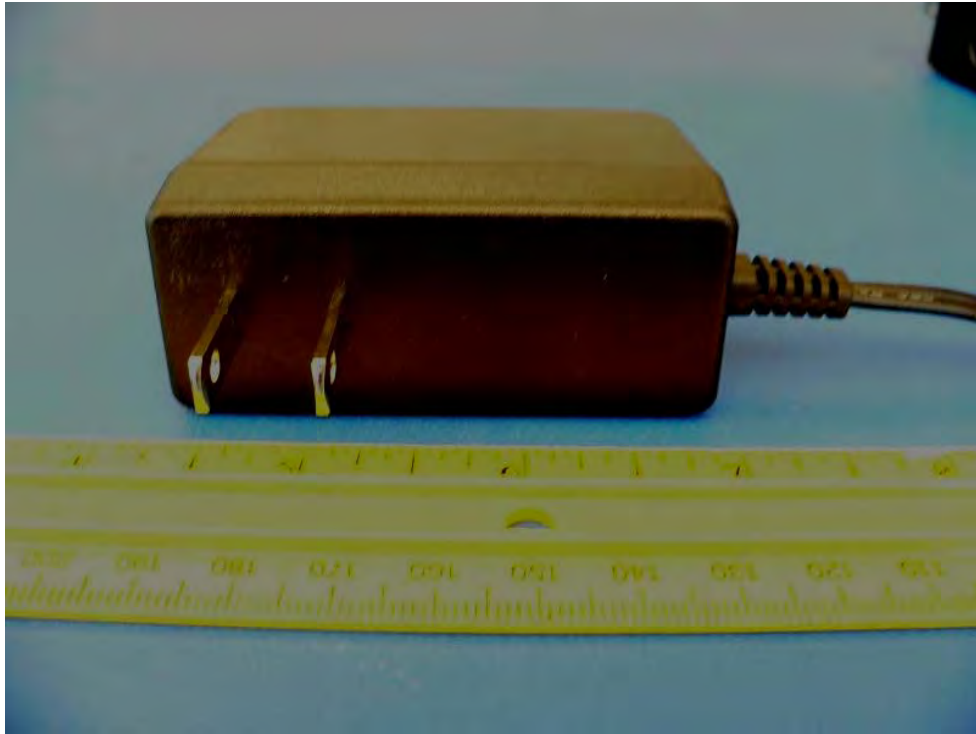

**9.18 Power Supply Type 2-2 (Front)**



**9.19 Power Supply Type 2-2 (Rear)**

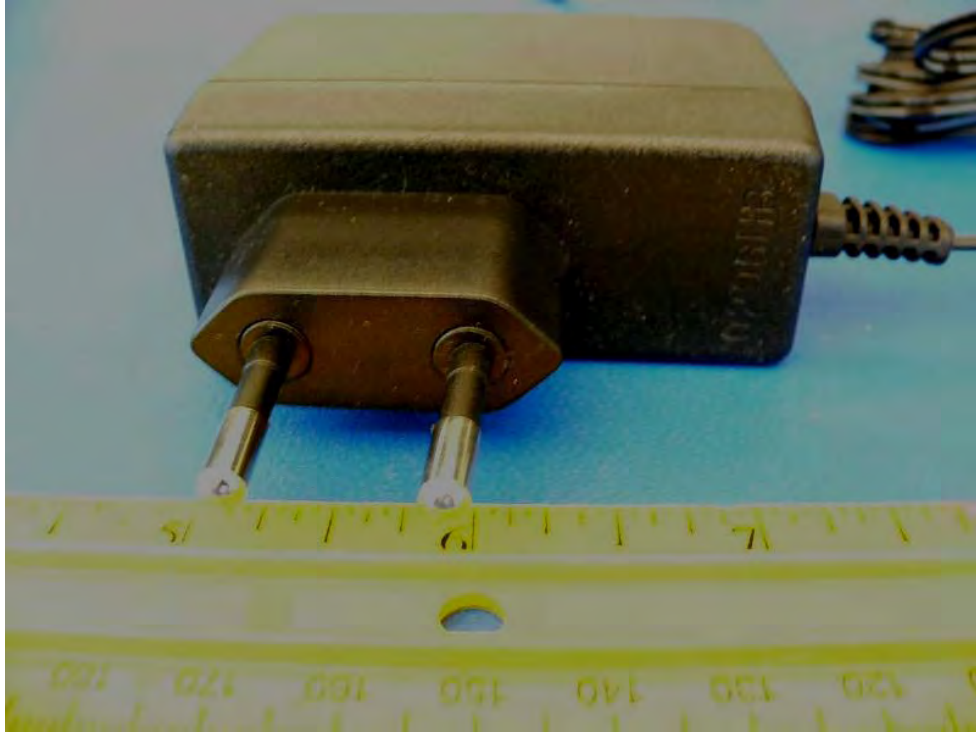

**9.20 Power Supply Type 2-3 (Front)**





**9.21 Power Supply Type 2-3 (Rear)**



**9.22 Power Supply Type 3-1 (Front)**



**9.23 Power Supply 3-1 (Rear)**

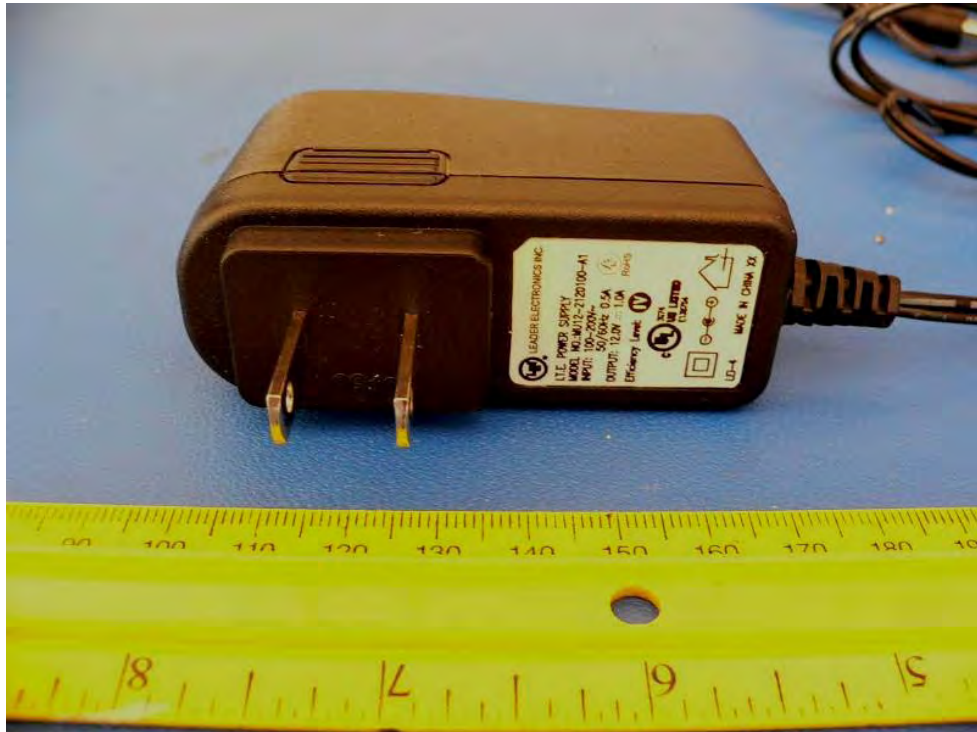

**9.24 Power Supply Type 3-2 (Front)**



**9.25 Power Supply Type 3-2 (Rear)**

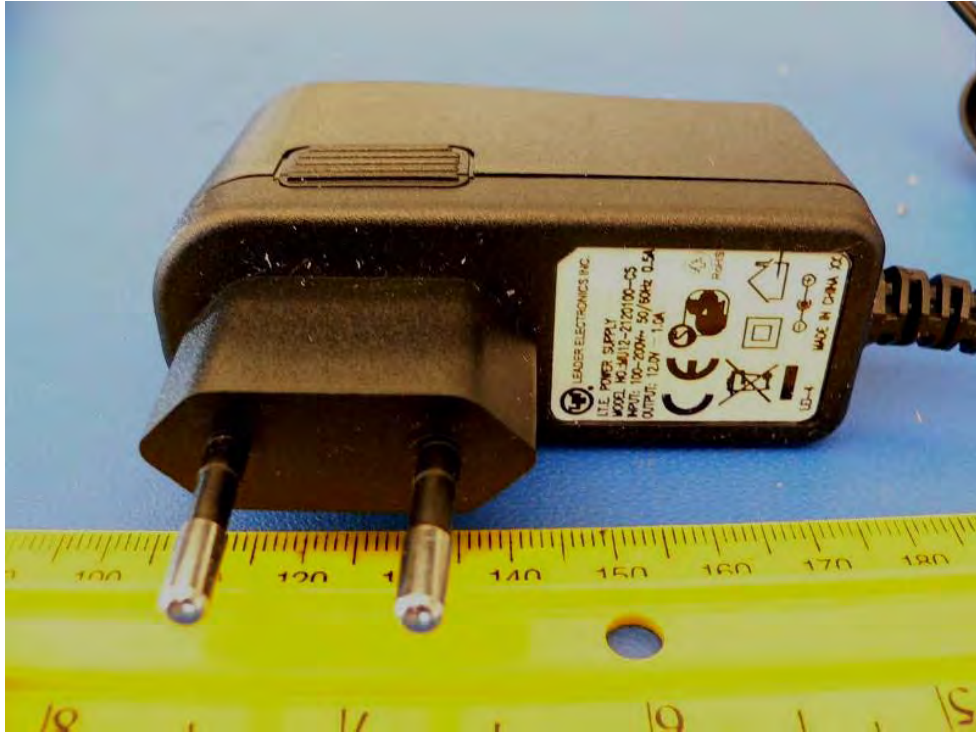

**9.26 Power Supply Type 3-3 (Front)**



**9.27 Power Supply Type 3-3 (Rear)**

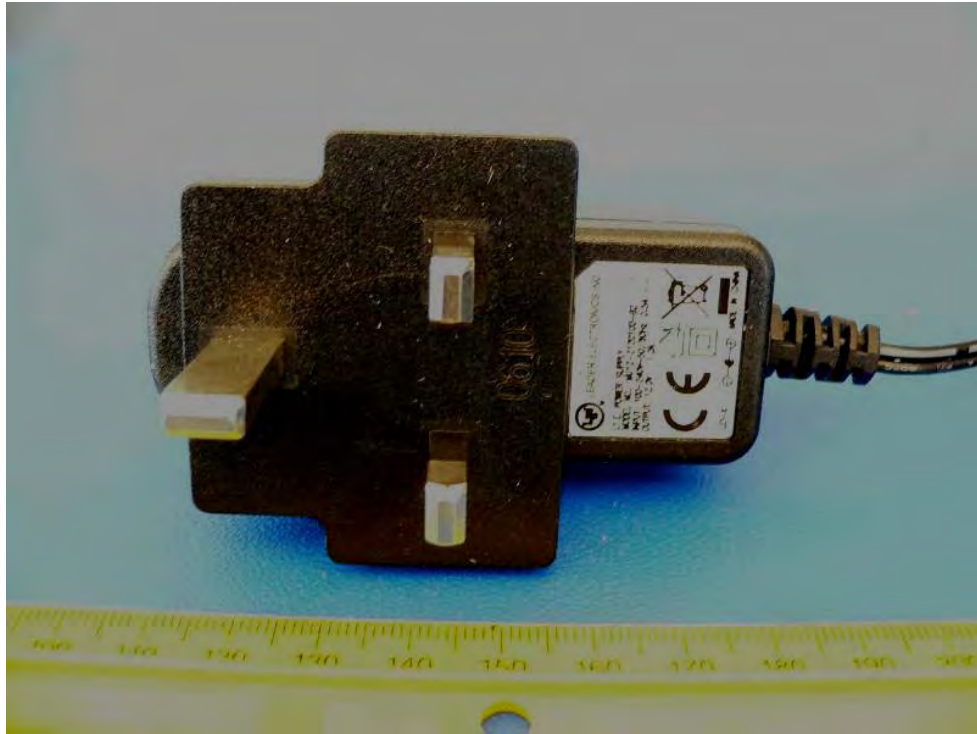

**END OF REPORT**