

FCC Antenna Summary



5GHz

Tested	Ruckus Model	Manufacturer	Manufacturer Model	Freq. Band	Antenna Gain	MiMO	Location
X	TBolt2	Ruckus	TBolt2	5150 - 5875MHz	15	2x2	Internal
	TBolt3	Ruckus	TBolt3	5150 - 5875MHz	8	3x3	Internal
	AT-0536-HP	Laird	OC51505	5150 - 5875MHz	5	single	External
	AT-0636-VP	Larson Antenna	W5027-1102	5150 - 5875MHz	5	single	External
	AT-1212-DP	MARS	MA-WE56-DP12RU	5150 - 5875MHz	12	2x2	External
X	AT-0505-MP	MARS	ME-WE2458-3H	4900 - 6100 MHz	5	3x3	External
	Corfu Omni	Ruckus	Corfu Omni	5152 - 5875MHz	3	3x3	Internal
X1	ZoneFlex 7982 Omni	Ruckus	ZoneFlex 7982 Omni	5152 - 5875MHz	3	3x3	Internal

X1 - Tested for initial FCC Grant



## Corfu omni antenna patterns

Engineer	Manager
	
08/26/2012	08/26/2012

### Ruckus Wireless Inc.

880 West Maude Ave.  
Suite 101  
Sunnyvale, CA 94085, USA  
Tel: (650) 265-4200  
Fax: (408) 738-2065

Patterns for 2.4GHz antenna:

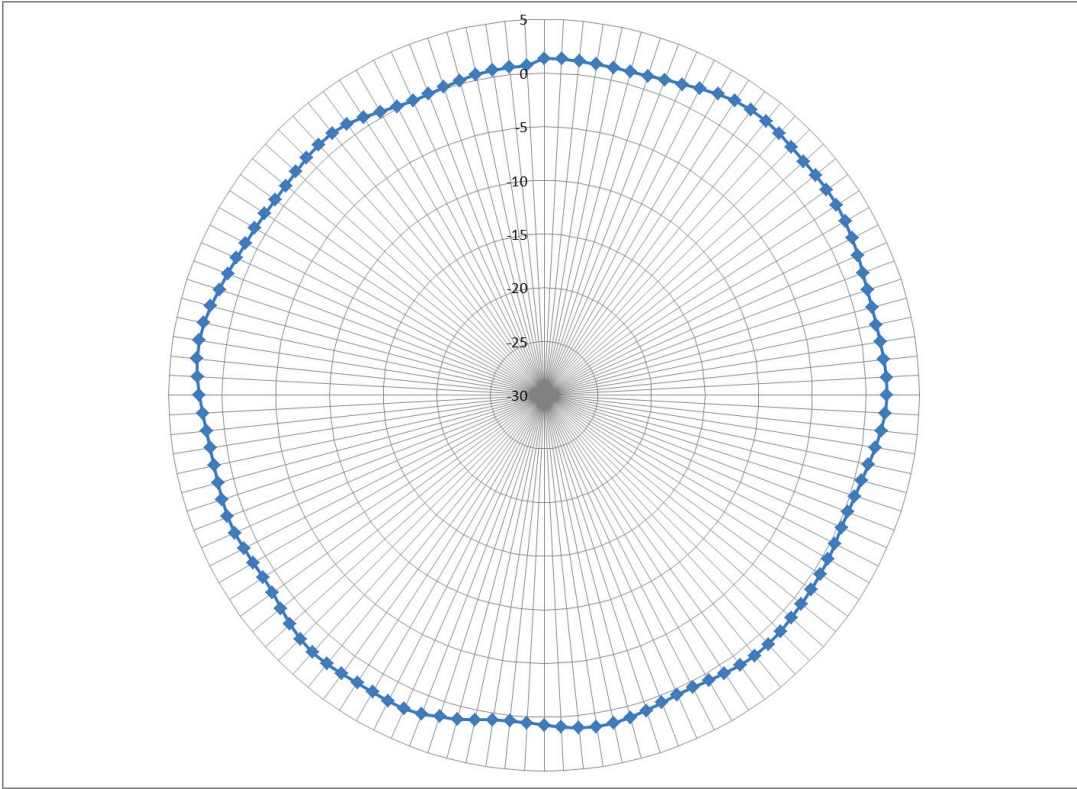

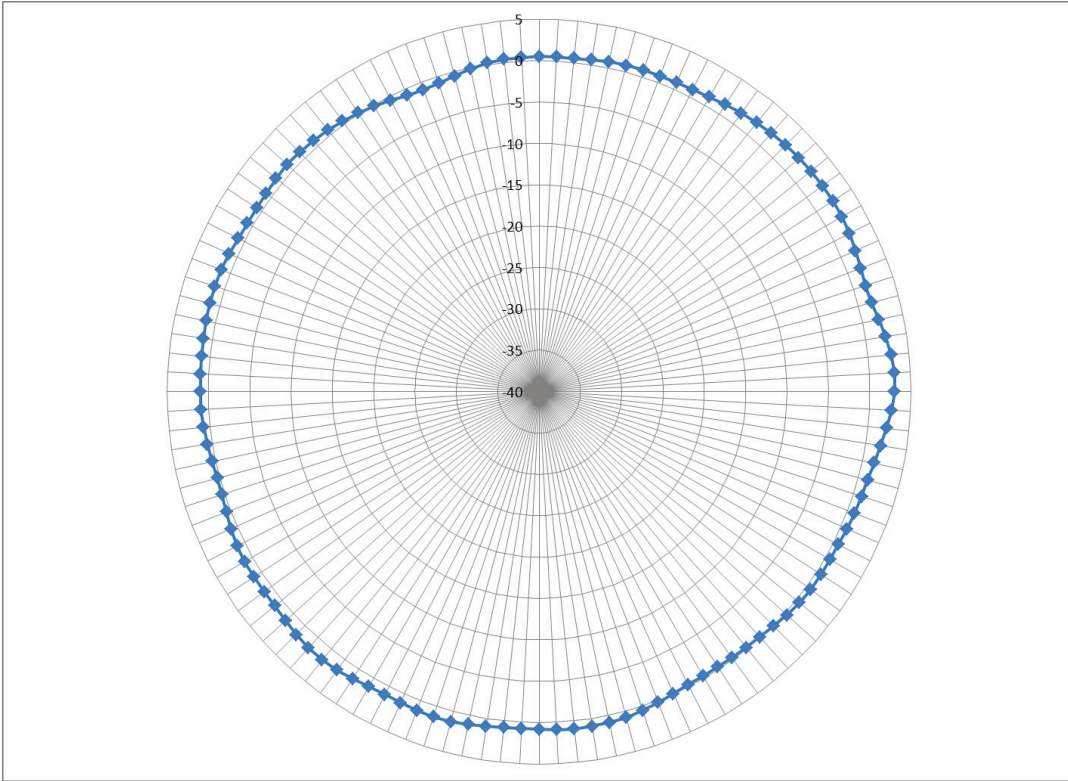

Patterns for 5GHz antenna:



Conclusion: Antenna patterns were measured in an anechoic chamber and it was determined that the highest gain for 2.4GHz antenna is 3dBi and 5GHz antenna is 3dBi.



## TBolt2 Antenna Patterns

Engineer	Manager
	
04/06/2012	04/06/2012

### Ruckus Wireless Inc.

880 West Maude Ave.  
Suite 101  
Sunnyvale, CA 94085, USA  
Tel: (650) 265-4200  
Fax: (408) 738-2065

Patterns for 2.4GHz antenna:

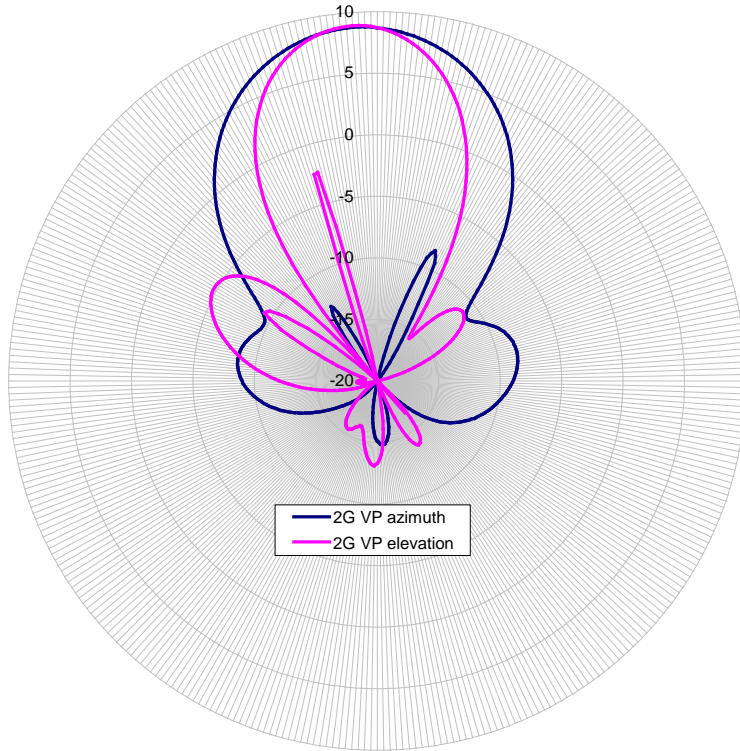

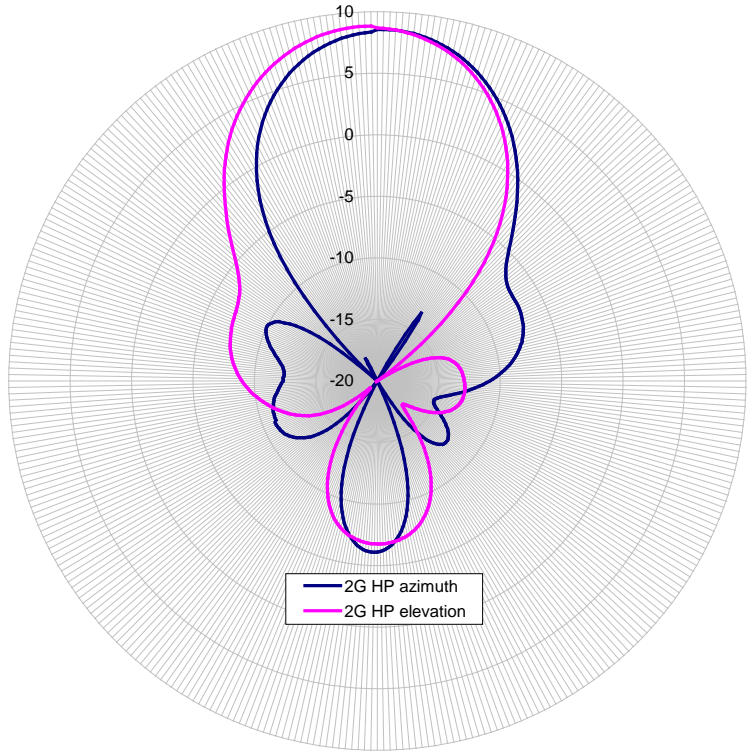



Patterns for 5GHz antenna:

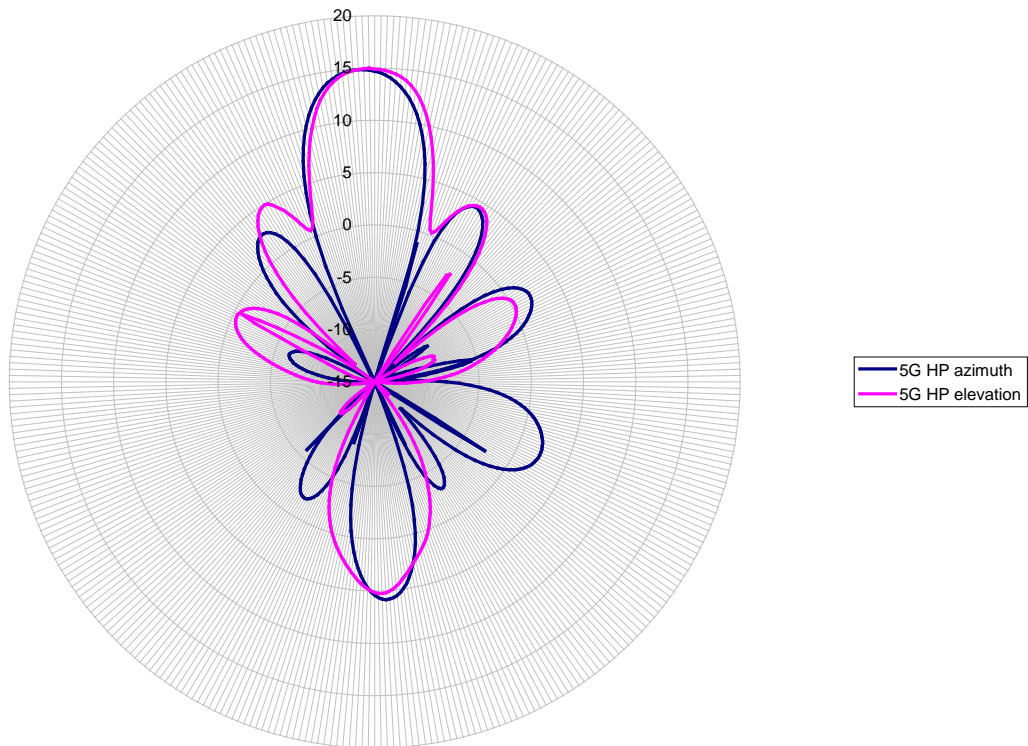
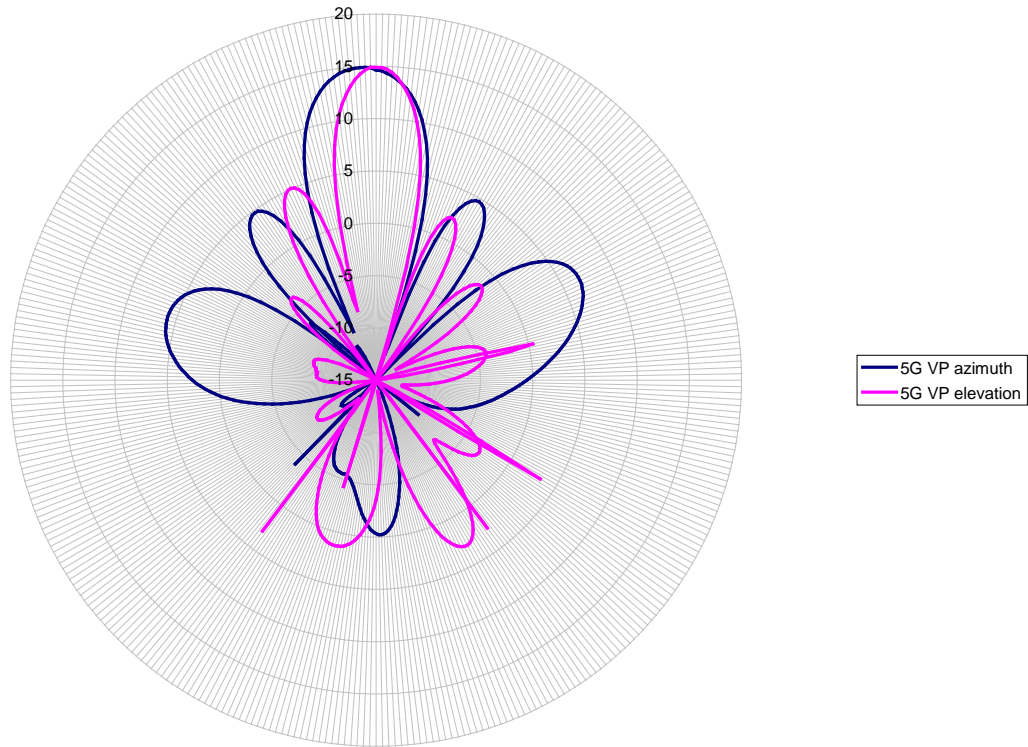





Conclusion: Antenna patterns were measured in an anechoic chamber and it was determined that the highest gain for 2.4GHz antenna is 9dBi and 5GHz antenna is 15dBi.



## TBolt3 Antenna Patterns

Engineer	Manager
	
04/06/2012	04/06/2012

### Ruckus Wireless Inc.

880 West Maude Ave.  
Suite 101  
Sunnyvale, CA 94085, USA  
Tel: (650) 265-4200  
Fax: (408) 738-2065

Patterns for 2.4GHz antenna:

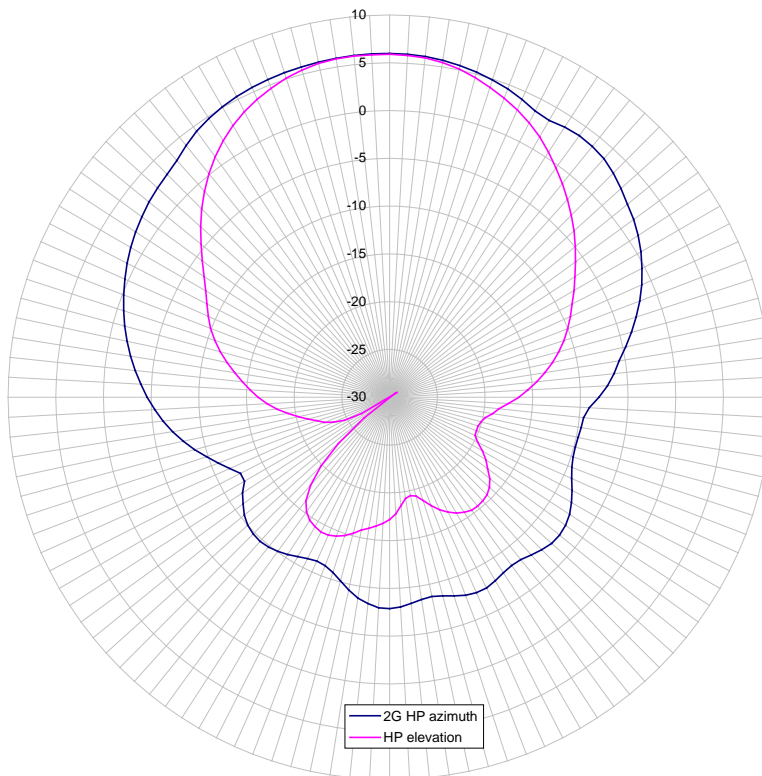
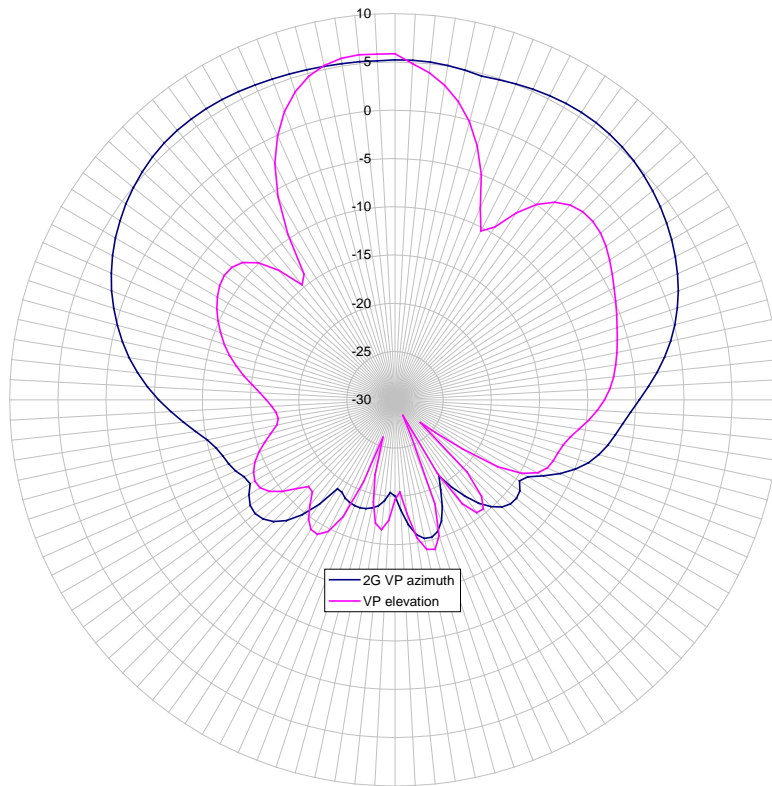



Patterns for 5GHz antenna:

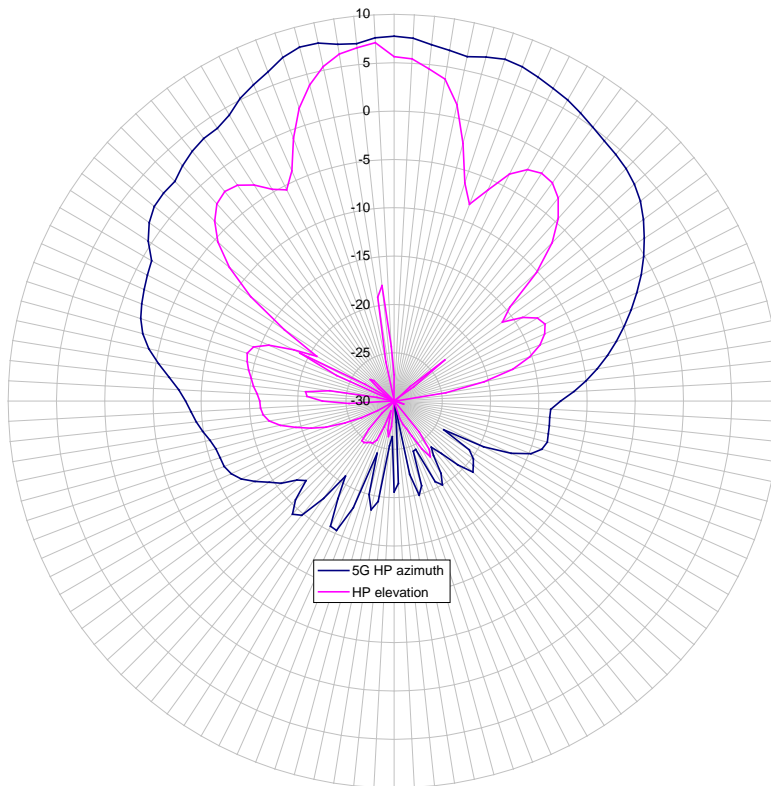
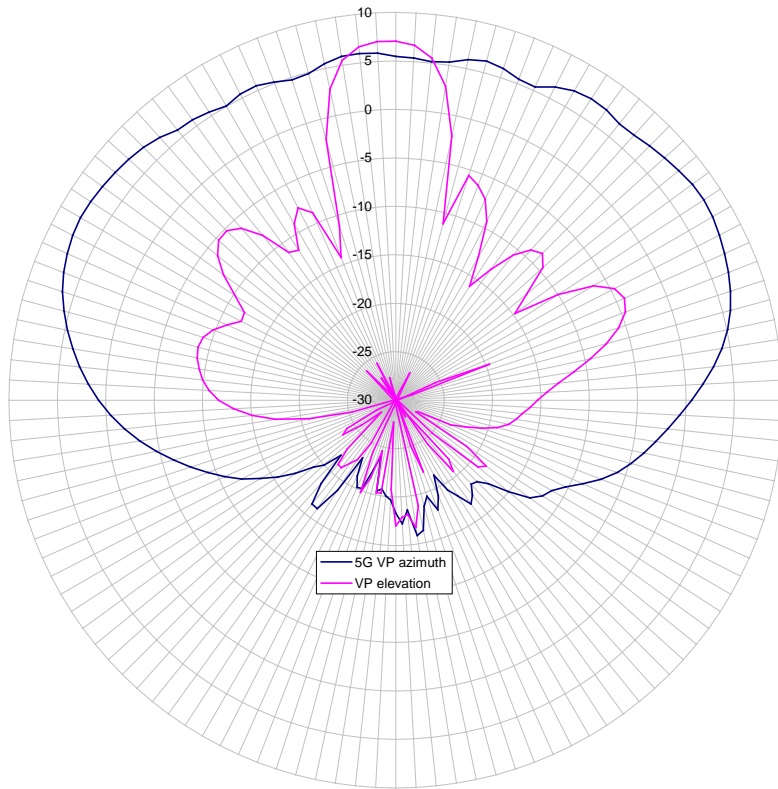

Conclusion: Antenna patterns were measured in an anechoic chamber and it was determined that the highest gain for 2.4GHz antennas is 6dBi and 5GHz antennas is 8dBi.



**DIRECT MOUNT 5 dBi VERTICALLY POLARIZED OMNI**

The Laird Technologies' OC51505 is a 5150-5875 MHz omnidirectional, collinear, vertically polarized array especially designed to compliment interior or exterior mounted wireless network systems. An integrated RF connector is imbedded in the antenna base cap for direct AP mounting. Special venting permits either upright or inverted orientation in outdoor locations. The antenna may also be pole-mounted when separation from the AP is required for optimum positioning.

**FEATURES** 

- Vertically polarized omnidirectional
- Rugged, lightweight and water resistant
- Full 802.11a wide band performance
- Direct to radio mounting
- 5 GHz broad band WLAN

**MARKETS**

- College campuses
- Airports
- Hospitals
- Transportation centers

PARAMETER	SPECIFICATION
Antenna Part Number	OC51505
Frequency Range	5150 - 5875 MHz
Gain	5 dBi
Polarization	Linear, Vertical
VSWR	2.0:1
3 dB Beamwidth - E-plane	29°
3 dB Beamwidth - H-plane	Omnidirectional
RF Connector	Type N, Male or Female, Standard
Power	10 Watts
Weight	0.14 kg
Radome	Polycarbonate, UV, White
Operational Temperature	-30°C to +70°C
Storage Temperature	-40°C to +85°C
Mounting	Connector Fixed or Mast Mount Kit, Upright and Inverted Orientation

All antennas carry a 1-Year Warranty

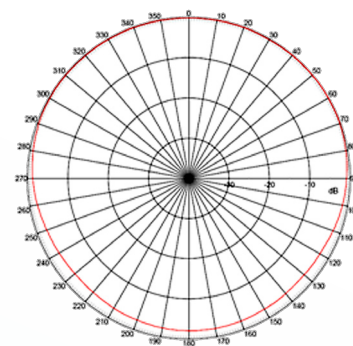

H-plane 5.5 GHz

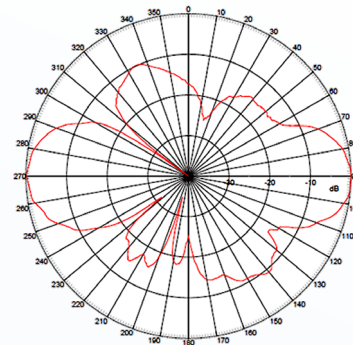

E-plane 5.5 GHz

**global solutions: local support™**

Americas: +1.847.839.6907  
IAS-AmericasEastSales@lairdtech.com

Europe: +1.32.80.7866.12  
IAS-EUSales@lairdtech.com

Asia: +1.65.6.243.8022  
IAS-AsiaSales@lairdtech.com

[www.lairdtech.com](http://www.lairdtech.com)

ANT-DS-OC51505 0910

Any information furnished by Laird Technologies, Inc. and its agents is believed to be accurate and reliable. All specifications are subject to change without notice. Responsibility for the use and application of Laird Technologies materials rests with the end user, since Laird Technologies and its agents cannot be aware of all potential uses. Laird Technologies makes no warranties as to the fitness, merchantability or suitability of any Laird Technologies materials or products for any specific or general uses. Laird Technologies shall not be liable for incidental or consequential damages of any kind. All Laird Technologies products are sold pursuant to the Laird Technologies' Terms and Conditions of sale in effect from time to time, a copy of which will be furnished upon request. © Copyright 2010 Laird Technologies, Inc. All Rights Reserved. Laird, Laird Technologies, the Laird Technologies Logo, and other marks are trade marks or registered trade marks of Laird Technologies, Inc. or an affiliate company thereof. Other product or service names may be the property of third parties. Nothing herein provides a license under any Laird Technologies or any third party intellectual property rights.



**5.15-5.825 MHz RADOME OMNI – 5 dBi**  
**OMNIDIRECTIONAL ANTENNA**

**W5027**

Series : ANTENNA

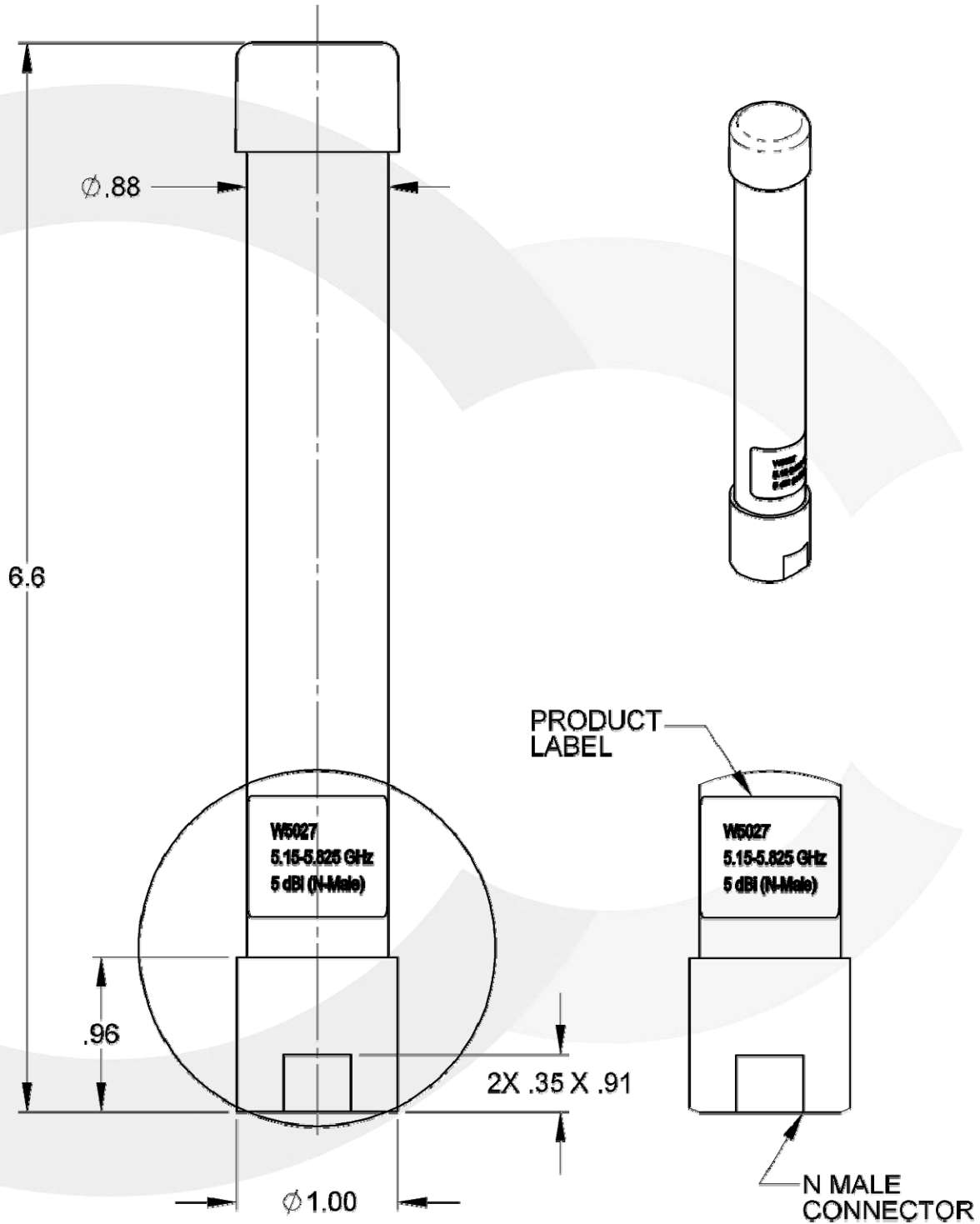

All dimensions are in inches

Issue : 1102

In the effort to improve our products, we reserve the right to make changes judged to be necessary.



**5.15-5.825 MHz RADOME OMNI – 5 dBi**  
**OMNIDIRECTIONAL ANTENNA**

**W5027**  
Series : **ANTENNA**

### ELECTRICAL SPECIFICATIONS

Frequency :.....	<b>5.15-5.825 MHz</b>
Nominal Impedance :.....	<b>50 Ω</b>
VSWR :.....	<b>2:1 Max</b>
Gain :.....	<b>5 dBi</b>
Radiation Pattern	
-3 dB beamwidth	
Horizontal Plane :	<b>Omni</b>
Vertical Plane :	<b>24° nominal</b>
Cross Polarization level	
Horizontal Plane :	<b>&gt;23 dB</b>
Vertical Plane :	<b>&gt;23 dB</b>
Polarization :.....	<b>VERTICAL</b>
Power withstanding :.....	<b>100 W</b>
Connector type :.....	<b>N Male</b>

### MECHANICAL SPECIFICATIONS

Radome : .....	<b>Pultruded Fiberglass, UV-Protected</b>
Plastic cap : .....	<b>Acrylonitrile Styrene Acrylate (ASA)</b> <b>UL File-N°. E41871 (UL 94 – HB)</b>
Adhesive :.....	<b>3M Scotch Weld™ DP-190 Gray</b>
Color :.....	<b>WHITE</b>
Ingress Protection :.....	<b>IP 67</b>
Weight :.....	<b>2.6 oz</b>
Wind-loading : .....	<b>150 Mph</b>
Side-loading @ 1ft :.....	<b>30 lbs</b>
Vertical Pull : .....	<b>100 lbs</b>
Overall length : .....	<b>6.6 INCHES</b>

5.15-5.825 MHz RADOME OMNI – 5 dBi  
OMNIDIRECTIONAL ANTENNA

**W5027**  
Series : ANTENNA

**ENVIRONMENTAL SPECIFICATIONS**

Temperature: ..... **-40/+65 ° C**  
Ingress Protection :..... **IP 67**  
Temperature Cycling:..... **-40°C dwell 6 hours/+65°C dwell 6 hours**  
4 full cycles (no condensation)  
Leak Test:..... **Fully submerged 12”**  
12 hours (no water intrusion)

**OTHER SPECIFICATIONS**

**5.15-5.825 MHz RADOME OMNI – 5 dBi**  
**OMNIDIRECTIONAL ANTENNA**

**W5027**  
Series : ANTENNA

**CURVES**

**Horizontal plane**

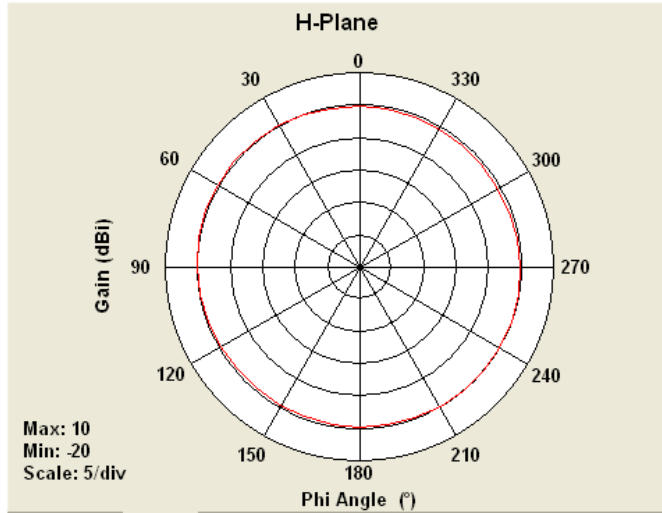

**Vertical plane**

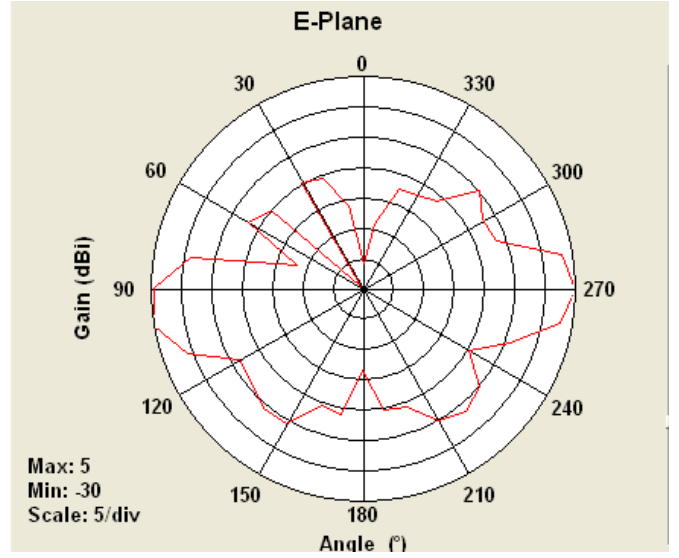

**VSWR**

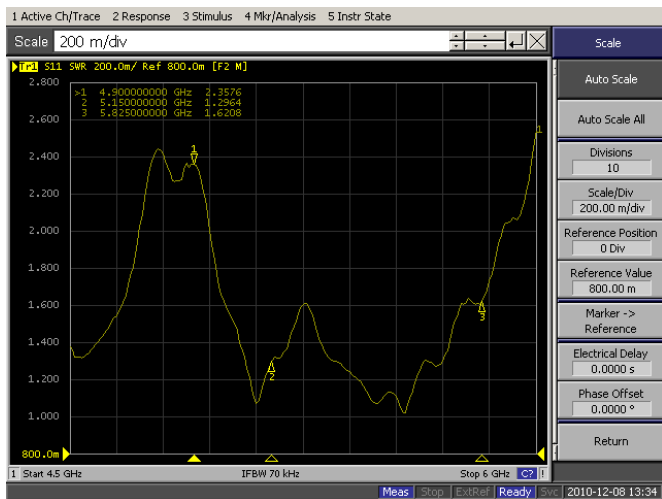

**Gain**

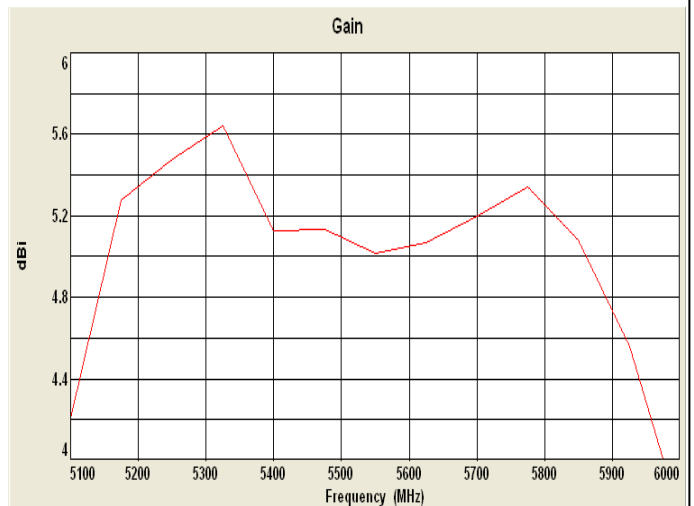

**Issue : 1102**

In the effort to improve our products, we reserve the right to make changes judged to be necessary.

## 5.15-5.875 GHz Dual Polarized Base Station Antenna, 120°

### MA-WE56-DP12RU

#### MARS 120° Broadband Dual Polarized Sector Antenna

##### Additional Features:

- stable performance with 12 dBi of gain
- compact size allowing for easy blending with any environment
- tilt mount allowing for quick and easy installation
- UV protected radome suitable for harsh environment installations

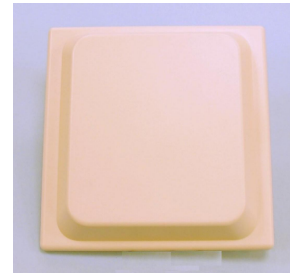

#### Specifications:

<b>Electrical</b>	
Frequency range	5.15 – 5.875 GHz
GAIN, typ.	12 dBi
VSWR, max.	1.7 : 1
Polarization	Dual, Vertical & Horizontal
3 dB Beam-Width, H-Plane, typ.	120°
3 dB Beam-Width, E-Plane, typ.	15°
Cross Polarization, typ.	-15 dB
Front to Back Ratio, min.	-30 dB
Port to Port Isolation, typ.	-20 dB
Input power, max	10 Watt
Input Impedance	50 Ohm
Lightning Protection	DC Grounded
<b>Mechanical</b>	
Dimensions (HxWxD)	200 x 200 x 33 mm (7.9" x7.9" x 1.25")
Weight	1 kg
Connector	2 x N-Type, Female
Back Plane	Aluminum protected through chemical passivation
Radome	UV Protected, Plastic
Mount	MNT-23
<b>Environmental</b>	
Operating Temperature Range	- 55°C to + 65°C
Vibration	According to IEC 60721-3-4
Wind Load	200 km/h (survival)
Flammability	UL94
Water Proofing	IP-67
Humidity	ETS 300 019-1-4, EN 302 085 (annex A.1.1)
Salt Fog	According to IEC 68-2-11
Ice and Snow	25mm radial (survival)
Service Life	>10 years

\* MARS reserves the right to make technical changes or modifications to any of its products and specifications without prior notice and without implementing such changes to prior supplied products. Product images are representative and indicative only. Warranty terms and general conditions of sale are applicable on any purchase of any product and are available on MARS website.

## 2.3-2.7 GHz & 4.9-6.1 GHz Dual Band MIMO Applications Sector Antenna, 120°

### MA-WE2458 -3H

MARS Dual Band Sector antenna provides coverage of 2.3 to 2.7 GHz & 4.9 to 6.1 GHz in a single antenna radome.

Additional Features:

- simultaneous coverage of 802.11 a,b,e,g,n,WiMAX & 4.9 GHz Public Safety Bands
- light weight and durable construction.
- UV protected radome made of plastic

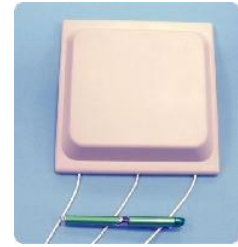

#### Specifications:

##### Electrical

Frequency range	2.3 - 2.7 GHz	4.9 - 6.1 GHz
Gain, typ.	5 dBi x3	5 dBi x3
VSWR, max.	2:1 (typ. 1.5:1)	2:1 (typ.1.5:1)
3 dB Beam-Width, H-Plane, typ.	120 °	120 °
3 dB Beam-Width, E-Plane, typ.	70 °	70 °
Polarization	Vertical and 2 x Dual Slant $\hat{A}\pm 45\hat{A}^\circ$	
Input power, max	20 Watt	
Input Impedance	50 Ohm	

##### Mechanical

Dimensions	200 x 200 x 33 mm (7.9" x7.9" x 1.25")
Weight	260 gr.
Connector	3 x Coaxial Cable RG 316 with RPSMA
Back Plane	Aluminum; protected through chemical passivation
Radome	UV Protected Plastic
Mount	Wall Mountable or See Ordering Options Below

##### Environmental

Operating Temperature Range	- 40°C to + 70°C
Vibration	According to IEC 60721-3-4
Flammability	UL94
Humidity	ETS 300 019-1-4, EN 302 085 (annex A.1.1)
Service Life	>10 years

##### Ordering Options

Antenna 3xCoaxial Cable RG 316 with N-Type male	MA-WE2458 -3H 2
Antenna 3x Coaxial Cable RG 316 with RPSMA, wall mountable	MA-WE2458 -3H
Antenna 3x Coaxial Cable RG 316 with N-Type male with provision for Az/EI adjustable mount MNT-22	MA-WE2458 -3H 2

MARS reserves the right to make technical changes or modifications to any of its products and specifications without prior notice and without implementing such changes to prior supplied products. Product images are representative and indicative only. Warranty terms and general conditions of sale are applicable on any purchase of any product and are available in the "Policies" section.