

FCC Test Report

EQUIPMENT : Tablet PC
BRAND NAME : Trimble
MODEL NAME : YUMA
FCC ID : S9EYUMA
STANDARD : FCC Part 15 Subpart C §15.247
CLASSIFICATION : Digital Transmission System (DTS)
APPLICANT : Tripod Data Systems, Inc.
345 SW Avery Ave. Corvallis, OR 97333

The product sample received on Oct. 07, 2008 and completely tested on Oct. 30, 2008. We, SPORTON INTERNATIONAL INC., would like to declare that the tested sample has been evaluated in accordance with the procedures given in ANSI C63.4-2003 and shown the compliance with the applicable technical standards.

The test results in this report apply exclusively to the tested model / sample. Without written approval of SPORTON INTERNATIONAL INC., the test report shall not be reproduced except in full.

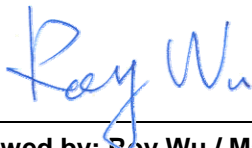

Reviewed by: Roy Wu / Manager



SPORTON INTERNATIONAL INC.

No. 52, Hwa Ya 1st Rd., Hwa Ya Technology Park, Kwei-Shan Hsiang, Tao Yuan Hsien, Taiwan, R.O.C.



TABLE OF CONTENTS

SUMMARY OF TEST RESULT 3

REVISION HISTORY..... 4

1 GENERAL DESCRIPTION 5

 1.1 Applicant 5

 1.2 Manufacturer..... 5

 1.3 Feature of Equipment Under Test 5

 1.4 Testing Site..... 7

 1.5 Applied Standards 7

 1.6 Ancillary Equipment List 7

2 TEST CONFIGURATION OF EQUIPMENT UNDER TEST 8

 2.1 Pre-Scanned RF Power..... 8

 2.2 Test Mode..... 9

 2.3 Connection Diagram of Test System..... 10

 2.4 RF Utility 10

3 TEST RESULT..... 11

 3.1 6dB Bandwidth Measurement 11

 3.2 Output Power Measurement..... 16

 3.3 Band Edges Measurement 18

 3.4 Power Spectral Density Measurement 25

 3.5 AC Conducted Emission Measurement..... 30

 3.6 Radiated Emission Measurement..... 34

 3.7 Antenna Requirements..... 68

4 LIST OF MEASURING EQUIPMENTS 69

5 UNCERTAINTY OF EVALUATION 70

6 CERTIFICATION OF TAF ACCREDITATION 72

APPENDIX A. PHOTOGRAPHS OF EUT

APPENDIX B. SETUP PHOTOGRAPHS



SUMMARY OF TEST RESULT

Report Section	FCC Rule	IC Rule	Description	Limit	Result	Remark
3.1	15.247(a)(2)	A8.2(a)	6dB Bandwidth	$\geq 0.5\text{MHz}$	Pass	-
3.2	15.247(b)	A8.4	Power Output	$\leq 30\text{dBm}$	Pass	-
3.3	15.247(d)	A8.5	Frequency Band Edges	$\leq 20\text{dBc}$	Pass	-
3.4	15.247(e)	A8.2(b)	Power Spectral Density	$\leq 8\text{dBm}$	Pass	-
3.5	15.207	Gen 7.2.2	AC Conducted Emission	15.207(a)	Pass	Under limit 14.9 dB at 0.446 MHz
3.6	15.247(d)	A8.5	Transmitter Radiated Emission	15.209(a) & 15.247(d)	Pass	Under limit 7.06 dB at 38.37 MHz
3.7	15.203 & 15.247(b)	A8.4	Antenna Requirement	N/A	Pass	-



REVISION HISTORY

REPORT NO.	VERSION	DESCRIPTION	ISSUED DATE
FR8O0709A	Rev. 01	Initial issue of report	Nov. 11, 2008



1 General Description

1.1 Applicant

Tripod Data Systems, Inc.
345 SW Avery Ave. Corvallis, OR 97333

1.2 Manufacturer

GeTAC Technology(Kunshan) LTD.
No.269, 2nd Road, Export Processing Zone, Changjiang South Road, Kunshan, Jiangsu, P.R.C.

1.3 Feature of Equipment Under Test

Product Feature & Specification	
Equipment	Tablet PC
Brand Name	Trimble
Model Name	YUMA
Tx/Rx Frequency Range	2400 MHz ~ 2483.5 MHz
Number of Channels	11
Carrier Frequency of Each Channel	$2412+(n-1)*5$ MHz; n=1~11
Maximum Output Power to Antenna	802.11b : 17.25 dBm 802.11g : 22.88 dBm
Antenna Type	PIFA Antenna with gain -0.53 dBi
HW Version	R0F
SW Version	BIOS: R0.51S KBC: R0.51H Utility Version: UMPQUA-Utility-20.01.081013.0
Type of Modulation	802.11b : DSSS 802.11g : OFDM
EUT Stage	Identical Prototype

Tablet PC Specification List:

Sample A and sample B are almost the same; the differences between the two samples are color of appearance, RAM, HDD, and battery as following table:

Component		Sample A (Color: GRAY)	Sample B (Color: YELLOW)
CPU	Brand Name	Intel	
	Model Name	Z530	
	Specification	1.60GHZ	
RAM	Brand Name	HYNIX	SAMSUNG
	Model Name	HY5PS1G831CFP-S6	K4T1G084QQ-HCF7
	Specification	1GB DDR2	1GB DDR2
LCD Monitor	Brand Name	CPT	
	Model Name	CLAA070NA01CW	
	Specification	7",WIDE, R-FILM,NO-POLAR,LED-BL	
Touch Screen	Brand Name	MILDEX	
	Specification	7",5WIRE,SRII,ARAG,RETARDER 0, POLARIZER 45, 167.75 *102.65,GLASS	
Wireless LAN	Brand Name	Intel	
	Model Name	SHIRLEY PEAK V1X2	
	Specification	WIFI LINK 5100	
Bluetooth	Brand Name	BILLIONTON	
	Model Name	GUBTCR42M	
	Specification	2.1VERSION	
GPS	Brand Name	GLOBALSET	
	Model Name	ET-318	
	Specification	SiRF III	
HDD	Brand Name	SAMSUNG	SAMSUNG
	Model Name	MCCOE32GQMPR-M1A	HS06THB
	Specification	32GB,SSD	1.8",60GB
Camera	Brand Name	AZUREWAVE	
	Model Name	AM-2C003	
	Specification	VCM MOTOR,2M,AUTO FOCUS	
CCD	Brand Name	AZUREWAVE	
	Model Name	AM1B012	
	Specification	1/4-INCH SXGA SENSOR MI1320, 1.3M RIGHT SIDE PINOUT,60Hz	
AC/DC Adapter	Company Name	FSP GROUP INC.	
	Model Name	FSP050-1AD101C	
	Specification	12V,4.16A,50W,3PIN,100-240V, 1.3A, 50~60Hz	
Battery	Company Name	Panasonic	SANYO
	Model Name	BQ20z90	BQ20z90
	Specification	4CELLS,2S2P, 7.2V/5.1AH	2CELLS,2S1P, 7.4V/2.6AH

Remark: The above EUT's information was declared by manufacturer. Please refer to the specifications or user's manual for more detailed description.

1.4 Testing Site

Test Site	SPORTON INTERNATIONAL INC.		
Test Site Location	No. 52, Hwa Ya 1 st Rd., Hwa Ya Technology Park, Kwei-Shan Hsiang, Tao Yuan Hsien, Taiwan, R.O.C TEL: +886-3-3273456 / FAX: +886-3-3284978		
Test Site No.	Sporton Site No.		FCC/IC Registration No.
	CO05-HY	03CH06-HY	TW1022/4086B-1

1.5 Applied Standards

According to the specifications of the manufacturer, the EUT must comply with the requirements of the following standards:

- ♦ FCC Part 15 Subpart C §15.247
- ♦ FCC KDB Publication No. 558074 (Measurement Guidelines of DTS)
- ♦ ANSI C63.4-2003
- ♦ IC RSS-210 Issue 7

Remark:

1. All test items were verified and recorded according to the standards and without any deviation during the test.
2. This EUT has also been tested and complied with the requirements of FCC Part 15, Subpart B (DoC) which recorded in a separate test report.

1.6 Ancillary Equipment List

Item	Equipment	Trade Name	Model Name	FCC ID	Data Cable	Power Cord
1.	GPS Station	T&E	GS-50	N/A	N/A	Unshielded, 1.8 m
2.	WLAN AP	D-Link	DWL-7100AP	KA22003040018-1	N/A	Unshielded, 1.8 m
3.	Bluetooth Earphone	Engotech	ET-BH111	PQY471087	N/A	N/A
4.	RS-232 Mouse	State	MS-303	Fcc DoC	Shielded, 1.3 m	N/A
5.	i-pod	Apple	A1199	Fcc DoC	Shielded, 1.0 m	N/A

2 Test Configuration of Equipment Under Test

2.1 Pre-Scanned RF Power

Preliminary tests were performed in different data rate and recorded the RF power output in the following table:

802.11b

Channel	Frequency (MHz)	RF Power (dBm)			
		2.4GHz 802.11b Data Rate			
		1 Mbps	2 Mbps	5.5 Mbps	11 Mbps
CH 01	2412 MHz	15.54	15.58	16.72	17.12
CH 06	2437 MHz	15.64	15.79	16.9	17.25
CH 11	2462 MHz	15.57	15.72	16.96	17.24

802.11g

Channel	Frequency (MHz)	RF Power (dBm)							
		2.4GHz 802.11g Data Rate							
		6 Mbps	9 Mbps	12 Mbps	18 Mbps	24 Mbps	36 Mbps	48 Mbps	54 Mbps
CH 01	2412 MHz	22.08	22.03	21.93	21.87	22.69	22.48	21.07	19.59
CH 06	2437 MHz	22.88	22.59	22.53	22.34	22.43	22.74	21.12	20.01
CH 11	2462 MHz	22.21	22.54	22.25	21.96	22.48	22.41	20.73	19.53

Remark:

1. The 802.11b data rates were set in 11 Mbps and 802.11g data rates were set in 6 Mbps for all the test cases, due to the highest RF output power.
2. The EUT is programmed to transmit signal continuously for all testing.

2.2 Test Mode

The EUT has been associated with peripherals pursuant to ANSI C63.4-2003 and configuration operated in a manner tended to maximize its emission characteristics in a typical application. Frequency range investigated: conducted emission (150 kHz to 30 MHz), radiated emission (30 MHz to the 10th harmonic of the highest fundamental frequency or to 40 GHz, whichever is lower). Pre-scanned tests were conducted to determine the final configuration from all possible combinations. The following tables are showing the test modes as the worst cases and recorded in this report.

Test Cases		
Test Item	Modulation	
	802.11b DSSS	802.11g OFDM
Conducted TCs	<ul style="list-style-type: none"> ■ Mode 1: CH01_2412 MHz ■ Mode 2: CH06_2437 MHz ■ Mode 3: CH11_2462 MHz 	<ul style="list-style-type: none"> ■ Mode 4: CH01_2412 MHz ■ Mode 5: CH06_2437 MHz ■ Mode 6: CH11_2462 MHz
Radiated TCs	<ul style="list-style-type: none"> ■ Mode 1: Sample A in CH01_2412 MHz ■ Mode 2: Sample A in CH06_2437 MHz ■ Mode 3: Sample A in CH11_2462 MHz ■ Mode 4: Sample B in CH01_2412 MHz 	<ul style="list-style-type: none"> ■ Mode 5: Sample A in CH01_2412 MHz ■ Mode 6: Sample A in CH06_2437 MHz ■ Mode 7: Sample A in CH11_2462 MHz ■ Mode 8: Sample B in CH01_2412 MHz
AC Conducted Emission	<p>Mode 1 : Sample A + WLAN Link + BT Link + Camera + TC + GPS Rx + Adapter</p> <p>Mode 2 : Sample B + WLAN Link + BT Link + Camera + TC + GPS Rx + Adapter</p>	
<p>Remark: 1. TC was "iPod + Mouse + Earphone + MPEG4".</p> <p>2. The boldface mode was the worst case of the conducted emission; only the test data was reported.</p>		

2.3 Connection Diagram of Test System

<Conducted Emission>

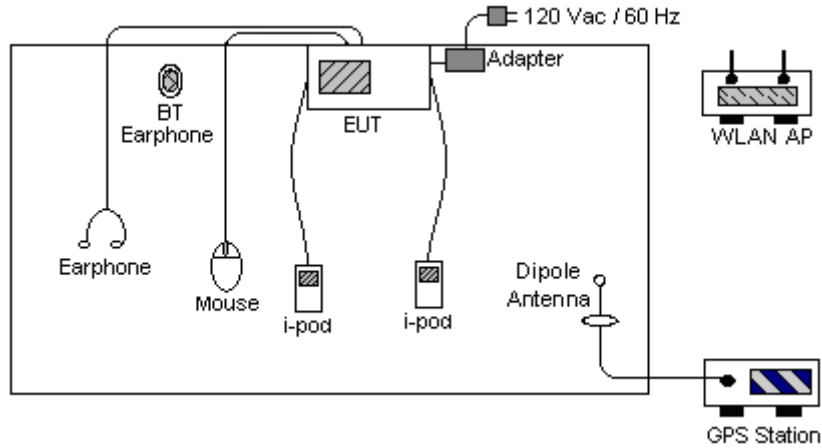

<Radiated Emission >

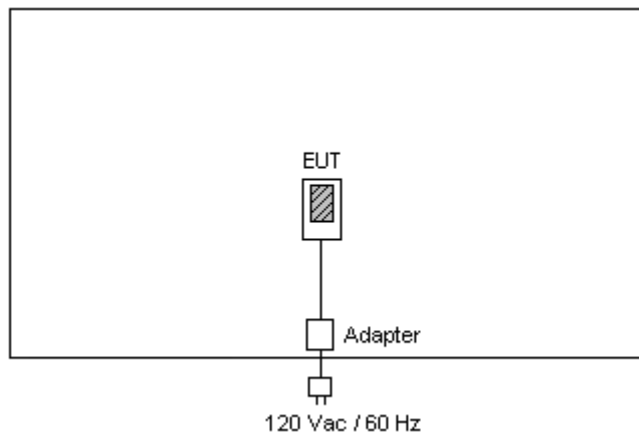

2.4 RF Utility

Executed "CRTU" to keep the EUT transmitting WLAN signals.

3 Test Result

3.1 6dB Bandwidth Measurement

3.1.1 Limit of 6dB Bandwidth

The minimum 6 dB bandwidth shall be at least 500 kHz.

3.1.2 Measuring Instruments

See list of measuring instruments of this test report.

3.1.3 Test Procedures

1. The testing follows FCC KDB Publication No. 558074 (Measurement Guidelines of DTS).
2. The RF output of EUT was connected to the spectrum analyzer by a low loss cable.
3. Make the measurement with the spectrum analyzer's resolution bandwidth (RBW) = 100 kHz.
In order to make an accurate measurement, set the span greater than RBW. The 6 dB bandwidth must be greater than 500 kHz.
4. The marker-delta reading at this point is the 6 dB bandwidth of the emission.

3.1.4 Test Setup

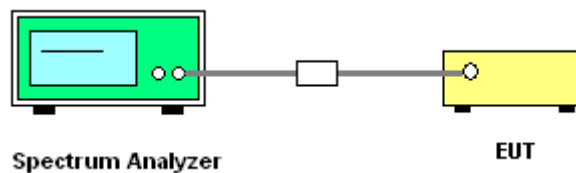

3.1.5 Test Result of 6dB Bandwidth

Test Mode :	Mode 1, 2, 3	Temperature :	27~28°C
Test Engineer :	Jack Jeng	Relative Humidity :	47~48%

Channel	Frequency (MHz)	6dB Bandwidth (MHz)	6dB Bandwidth Min. Limit (MHz)	Pass/Fail
01	2412	11.12	0.5	Pass
06	2437	11.12	0.5	Pass
11	2462	11.12	0.5	Pass

Test Mode :	Mode 4, 5, 6	Temperature :	27~28°C
Test Engineer :	Jack Jeng	Relative Humidity :	47~48%

Channel	Frequency (MHz)	6dB Bandwidth (MHz)	6dB Bandwidth Min. Limit (MHz)	Pass/Fail
01	2412	16.36	0.5	Pass
06	2437	16.36	0.5	Pass
11	2462	16.36	0.5	Pass



3.1.6 Test Result of 6dB Bandwidth Plots

Mode 1 : 6 dB Bandwidth Plot on 802.11b Channel 01

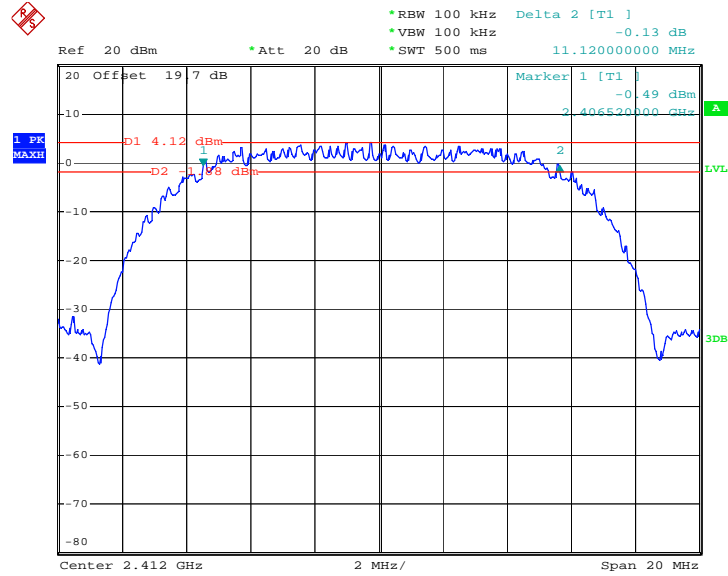

Date: 24.OCT.2008 06:34:10

Mode 2 : 6 dB Bandwidth Plot on 802.11b Channel 06

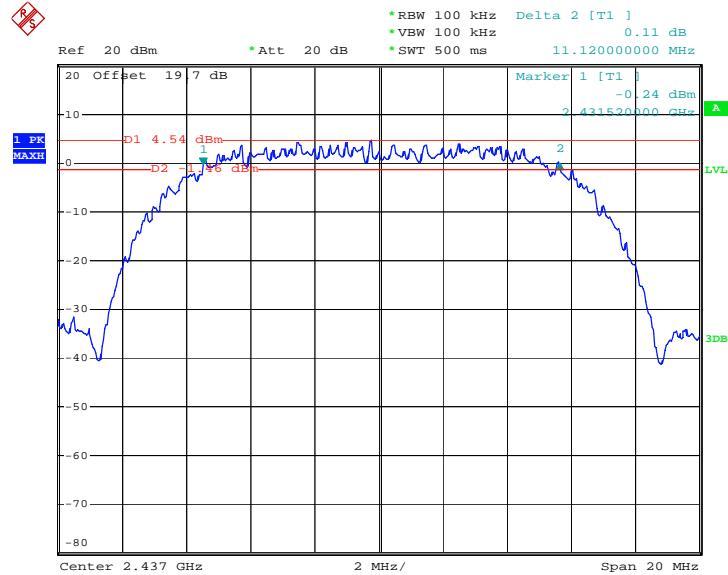

Date: 24.OCT.2008 06:35:06



Mode 3 : 6 dB Bandwidth Plot on 802.11b Channel 11

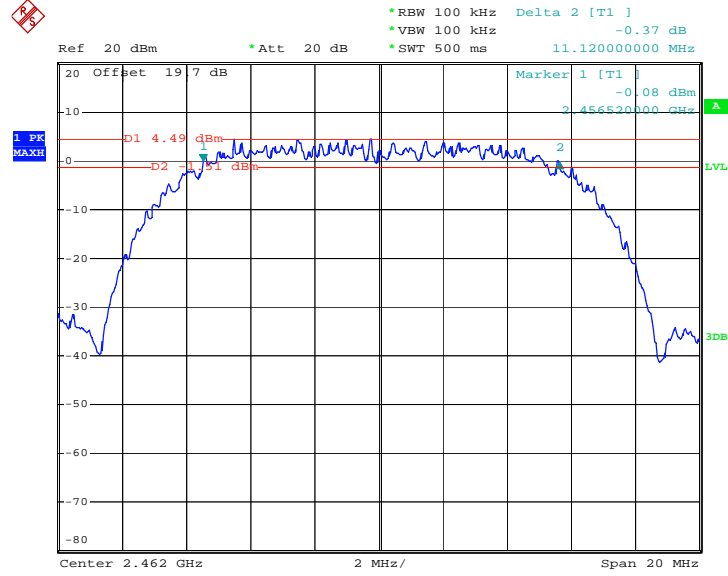

Date: 24.OCT.2008 06:36:11

Mode 4 : 6 dB Bandwidth Plot on 802.11g Channel 01

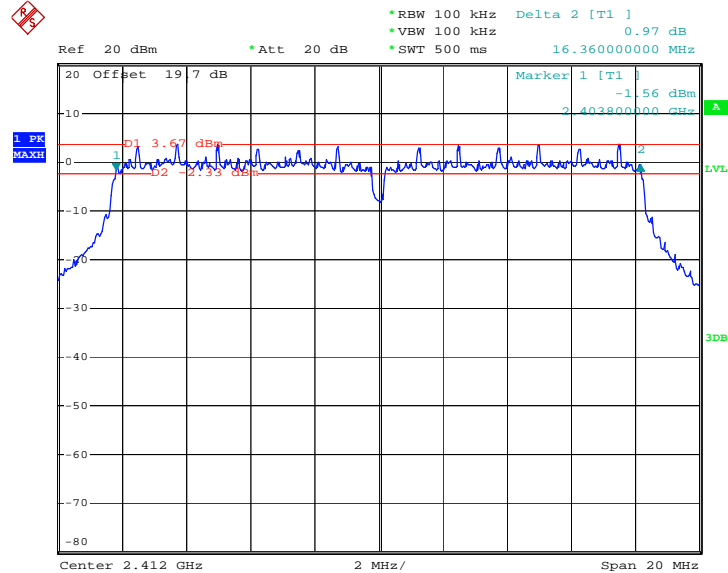

Date: 24.OCT.2008 06:42:14



Mode 5 : 6 dB Bandwidth Plot on 802.11g Channel 06

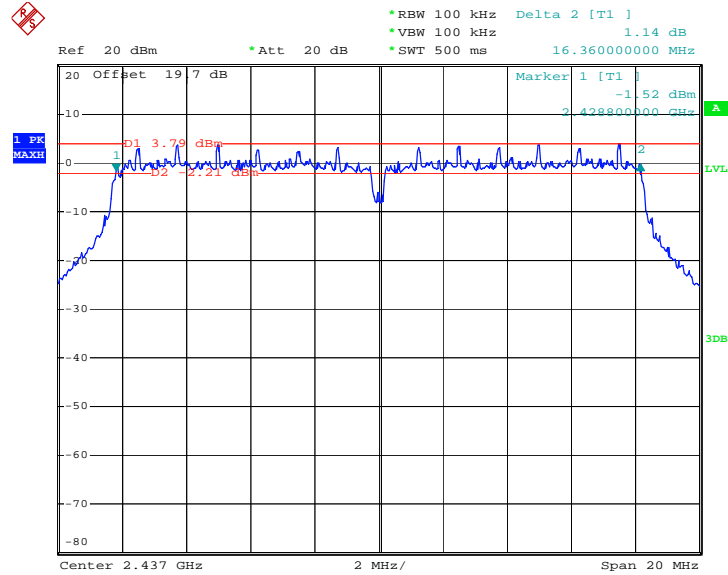

Date: 24.OCT.2008 06:41:28

Mode 6 : 6 dB Bandwidth Plot on 802.11g Channel 11

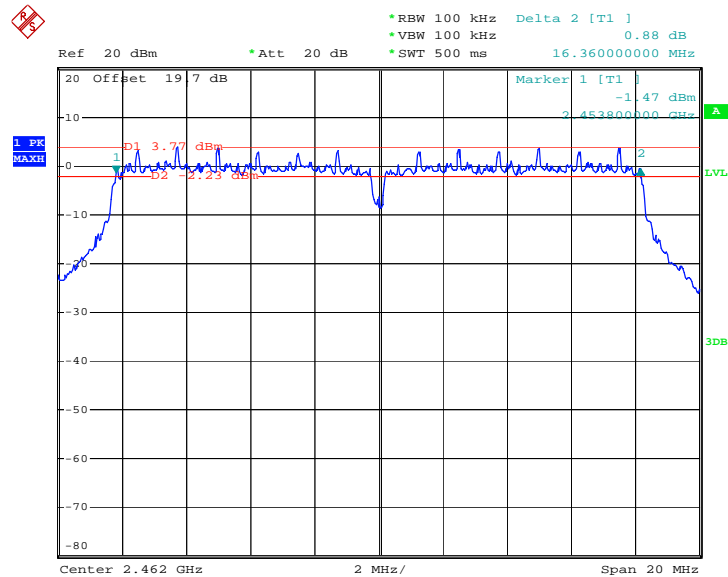

Date: 24.OCT.2008 06:40:38

3.2 Output Power Measurement

3.2.1 Limit of Output Power

For systems using digital modulation in the 2400-2483.5MHz, the limit for peak output power is 30dBm. If transmitting antenna of directional gain greater than 6dBi are used the peak output power from the intentional radiator shall be reduced below the above stated value by the amount in dB that the directional gain of the antenna exceeds 6 dBi. In case of point-to-point operation, the limit has to be reduced by 1dB for every 3dB that the directional gain of the antenna exceeds 6dBi.

3.2.2 Measuring Instruments

See list of measuring instruments of this test report.

3.2.3 Test Procedures

1. The testing follows FCC KDB Publication No. 558074 (Measurement Guidelines of DTS).
2. The RF output of EUT was connected to the spectrum analyzer by a low loss cable.
3. Measure the power either by power meter or spectrum analyzer.

3.2.4 Test Setup

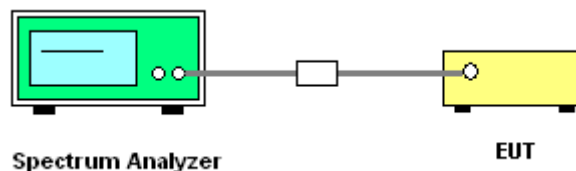

3.2.5 Test Result of Output Power

Test Mode :	Mode 1, 2, 3	Temperature :	27~28°C
Test Engineer :	Jack Jeng	Relative Humidity :	47~48%

Channel	Frequency (MHz)	Measured Output Power (dBm)	Max. Limits (dBm)	Pass/Fail
01	2412	17.12	30	Pass
06	2437	17.25	30	Pass
11	2462	17.24	30	Pass

Test Mode :	Mode 4, 5, 6	Temperature :	27~28°C
Test Engineer :	Jack Jeng	Relative Humidity :	47~48%

Channel	Frequency (MHz)	Measured Output Power (dBm)	Max. Limits (dBm)	Pass/Fail
01	2412	22.08	30	Pass
06	2437	22.88	30	Pass
11	2462	22.21	30	Pass

3.3 Band Edges Measurement

3.3.1 Limit of Band Edges

In any 100 kHz bandwidth outside the intentional radiation frequency band, the radio frequency power shall be at least 20 dB below the highest level of the radiated power. If the output power of this device was measured by spectrum analyzer, the attenuation under this paragraph shall be 30 dB instead of 20 dB.

3.3.2 Measuring Instruments

See list of measuring instruments of this test report.

3.3.3 Test Procedures

1. The testing follows the guidelines in ANSI C63.4-2003 and FCC KDB Publication No. 558074 (Measurement Guidelines of DTS).
2. Conducted emission test: Set RBW = 100 kHz, Video bandwidth (VBW) > RBW, scan up through 10th harmonic. Band edge emissions must be at least 20 dB below the highest emission level within the authorized band as measured with a 100 kHz RBW. Note: If the output power of this device was measured by power meter, the attenuation under this paragraph shall be 30 dB instead of 20 dB.
3. Radiated emission test: Apply to band edge emissions that fall in the restricted bands listed in FCC Section 15.205. The maximum permitted average field strength is listed in FCC Section 15.209. A pre-amp is necessary for this measurement. For measurements above 1 GHz, set RBW = 1MHz, VBW = 10 Hz, Sweep=Auto. If the emission is pulsed, modify the unit for continuous operation; use the settings shown above, then correct the reading by subtracting the peak-average correction factor, derived from the appropriate duty cycle calculation as in FCC Section 15.35(b) and (c).

3.3.4 Test Setup

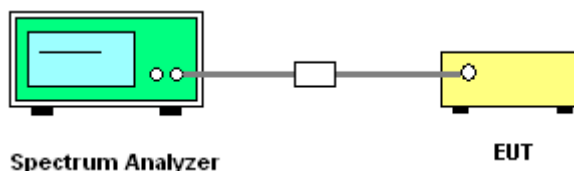



3.3.5 Test Result of Radiated Band Edges

Test Mode :	Mode 1	Temperature :	27~28°C
Test Channel :	01	Relative Humidity :	47~48%
Test Engineer :	Mac Lin and Andrew Hsiao		

ANTENNA POLARITY : HORIZONTAL										
Frequency (MHz)	Level (dBuV/m)	Over Limit (dB)	Limit Line (dBuV/m)	Read Level (dBuV)	Antenna Factor (dB)	Cable Loss (dB)	Preamp Factor (dB)	Ant Pos (cm)	Table Pos (deg)	Remark
2386.57	36.87	-17.13	54.00	36.65	31.98	3.92	35.68	131	44	Average
2386.57	50.24	-23.76	74.00	50.02	31.98	3.92	35.68	100	0	Peak

ANTENNA POLARITY : VERTICAL										
Frequency (MHz)	Level (dBuV/m)	Over Limit (dB)	Limit Line (dBuV/m)	Read Level (dBuV)	Antenna Factor (dB)	Cable Loss (dB)	Preamp Factor (dB)	Ant Pos (cm)	Table Pos (deg)	Remark
2389.42	32.95	-21.05	54.00	32.73	31.98	3.92	35.68	185	53	Average
2389.42	45.36	-28.64	74.00	45.14	31.98	3.92	35.68	100	0	Peak

Test Mode :	Mode 3	Temperature :	27~28°C
Test Channel :	11	Relative Humidity :	47~48%
Test Engineer :	Mac Lin and Andrew Hsiao		

ANTENNA POLARITY : HORIZONTAL										
Frequency (MHz)	Level (dBuV/m)	Over Limit (dB)	Limit Line (dBuV/m)	Read Level (dBuV)	Antenna Factor (dB)	Cable Loss (dB)	Preamp Factor (dB)	Ant Pos (cm)	Table Pos (deg)	Remark
2488.41	37.34	-16.67	54.00	36.88	32.10	4.05	35.70	128	58	Average
2488.41	53.61	-20.40	74.00	53.15	32.10	4.05	35.70	100	0	Peak

ANTENNA POLARITY : VERTICAL										
Frequency (MHz)	Level (dBuV/m)	Over Limit (dB)	Limit Line (dBuV/m)	Read Level (dBuV)	Antenna Factor (dB)	Cable Loss (dB)	Preamp Factor (dB)	Ant Pos (cm)	Table Pos (deg)	Remark
2487.65	33.90	-20.11	54.00	33.44	32.10	4.05	35.70	100	291	Average
2487.65	49.63	-24.38	74.00	49.17	32.10	4.05	35.70	100	0	Peak



Test Mode :	Mode 4	Temperature :	27~28°C
Test Channel :	01	Relative Humidity :	47~48%
Test Engineer :	Mac Lin and Andrew Hsiao		

ANTENNA POLARITY : HORIZONTAL										
Frequency (MHz)	Level (dBuV/m)	Over Limit (dB)	Limit Line (dBuV/m)	Read Level (dBuV)	Antenna Factor (dB)	Cable Loss (dB)	Preamp Factor (dB)	Ant Pos (cm)	Table Pos (deg)	Remark
2388.85	43.05	-10.95	54.00	42.83	31.98	3.92	35.68	130	46	Average
2388.85	64.52	-9.48	74.00	64.30	31.98	3.92	35.68	100	0	Peak

ANTENNA POLARITY : VERTICAL										
Frequency (MHz)	Level (dBuV/m)	Over Limit (dB)	Limit Line (dBuV/m)	Read Level (dBuV)	Antenna Factor (dB)	Cable Loss (dB)	Preamp Factor (dB)	Ant Pos (cm)	Table Pos (deg)	Remark
2388.85	37.28	-16.72	54.00	37.06	31.98	3.92	35.68	182	26	Average
2388.85	56.94	-17.06	74.00	56.72	31.98	3.92	35.68	100	0	Peak

Test Mode :	Mode 6	Temperature :	27~28°C
Test Channel :	11	Relative Humidity :	47~48%
Test Engineer :	Mac Lin and Andrew Hsiao		

ANTENNA POLARITY : HORIZONTAL										
Frequency (MHz)	Level (dBuV/m)	Over Limit (dB)	Limit Line (dBuV/m)	Read Level (dBuV)	Antenna Factor (dB)	Cable Loss (dB)	Preamp Factor (dB)	Ant Pos (cm)	Table Pos (deg)	Remark
2483.85	38.81	-15.19	54.00	38.38	32.08	4.05	35.70	156	42	Average
2483.85	60.07	-13.93	74.00	59.64	32.08	4.05	35.70	100	0	Peak

ANTENNA POLARITY : VERTICAL										
Frequency (MHz)	Level (dBuV/m)	Over Limit (dB)	Limit Line (dBuV/m)	Read Level (dBuV)	Antenna Factor (dB)	Cable Loss (dB)	Preamp Factor (dB)	Ant Pos (cm)	Table Pos (deg)	Remark
2483.50	34.51	-19.49	54.00	34.08	32.08	4.05	35.70	100	290	Average
2483.50	53.11	-20.89	74.00	52.68	32.08	4.05	35.70	100	0	Peak



3.3.6 Test Result of Conducted Band Edges

Test Mode :	Mode 1	Temperature :	27~28°C
Test Channel :	01	Relative Humidity :	47~48%
Test Engineer :	Jack Jeng		

Low Band Edge Plot on 802.11b Channel 01

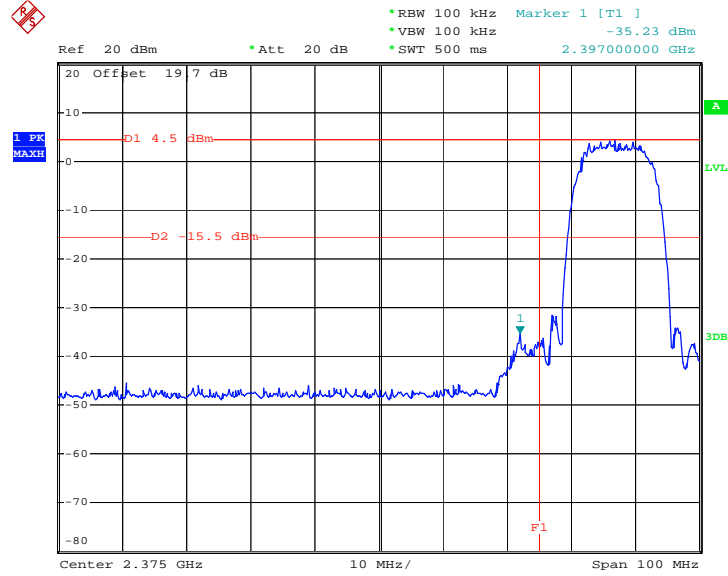

Date: 24.OCT.2008 06:38:17



Test Mode :	Mode 3	Temperature :	27~28°C
Test Channel :	11	Relative Humidity :	47~48%
Test Engineer :	Jack Jeng		

High Band Edge Plot on 802.11b Channel 11

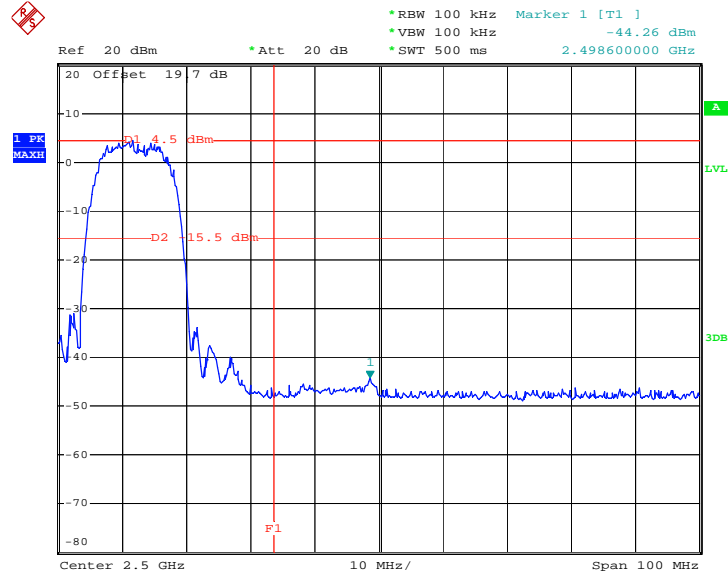

Date: 24.OCT.2008 06:37:09



Test Mode :	Mode 4	Temperature :	27~28°C
Test Channel :	01	Relative Humidity :	47~48%
Test Engineer :	Jack Jeng		

Low Band Edge Plot on 802.11g Channel 01

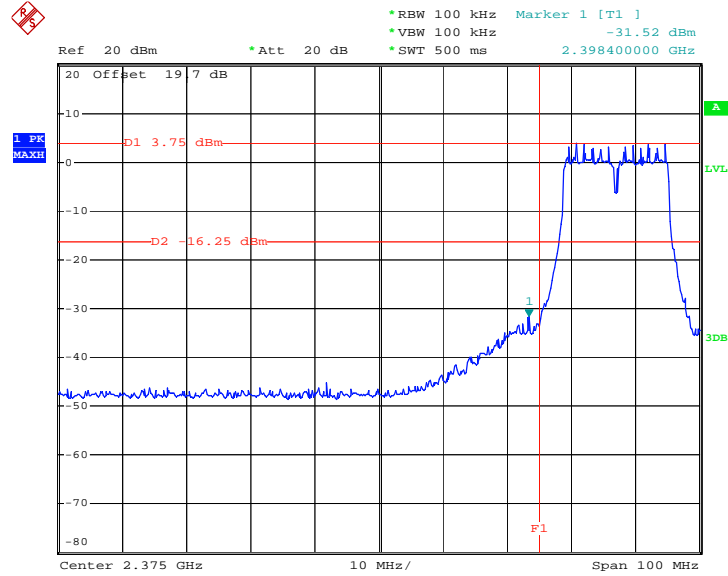

Date: 24.OCT.2008 06:38:52



Test Mode :	Mode 6	Temperature :	27~28°C
Test Channel :	11	Relative Humidity :	47~48%
Test Engineer :	Jack Jeng		

High Band Edge Plot on 802.11g Channel 11

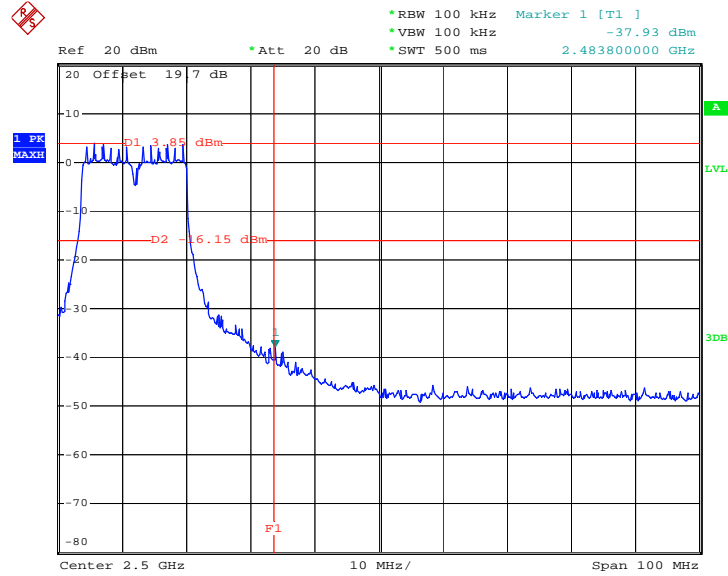

Date: 24.OCT.2008 06:39:37

3.4 Power Spectral Density Measurement

3.4.1 Limit of Power Spectral Density

The peak power spectral density shall not be greater than 8dBm in any 3kHz band at any time interval of continuous transmission.

3.4.2 Measuring Instruments

See list of measuring instruments of this test report.

3.4.3 Test Procedures

1. The test follows FCC KDB Publication No. 558074 (Measurement Guidelines of DTS).
2. The RF output of EUT was connected to the spectrum analyzer by a low loss cable.
3. Take the measured data from spectrum analyzer.

3.4.4 Test Setup

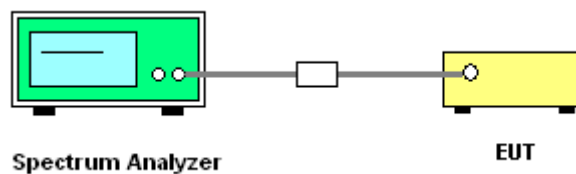



3.4.5 Test Result of Power Spectral Density

Test Mode :	Mode 1, 2, 3	Temperature :	27~28°C
Test Engineer :	Jack Jeng	Relative Humidity :	47~48%

Channel	Frequency (MHz)	Measured PSD (dBm)	Max. Limits (dBm)	Pass/Fail
01	2412	-10.32	8	Pass
06	2437	-9.19	8	Pass
11	2462	-9.17	8	Pass

Test Mode :	Mode 4, 5, 6	Temperature :	27~28°C
Test Engineer :	Jack Jeng	Relative Humidity :	47~48%

Channel	Frequency (MHz)	Measured PSD (dBm)	Max. Limits (dBm)	Pass/Fail
01	2412	-10.81	8	Pass
06	2437	-10.82	8	Pass
11	2462	-10.99	8	Pass



3.4.6 Test Result of Power Spectral Density Plots

Mode 1 : PSD Plot on 802.11b Channel 01

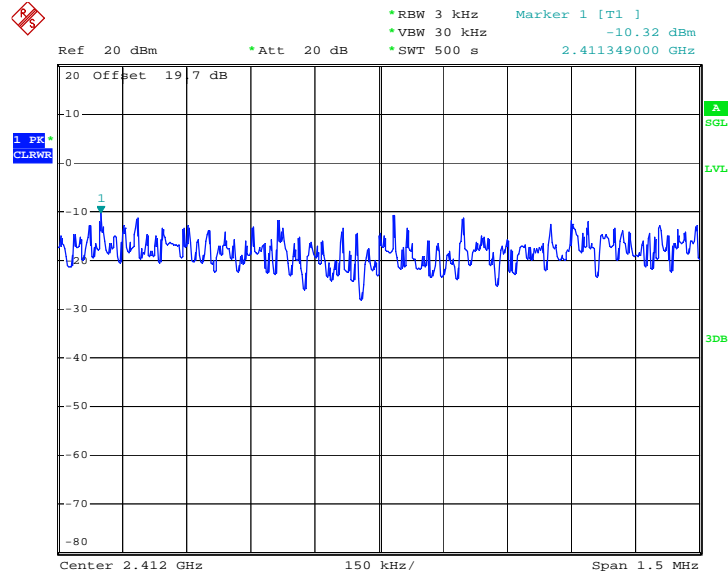

Date: 10.NOV.2008 13:04:39

Mode 2 : PSD Plot on 802.11b Channel 06

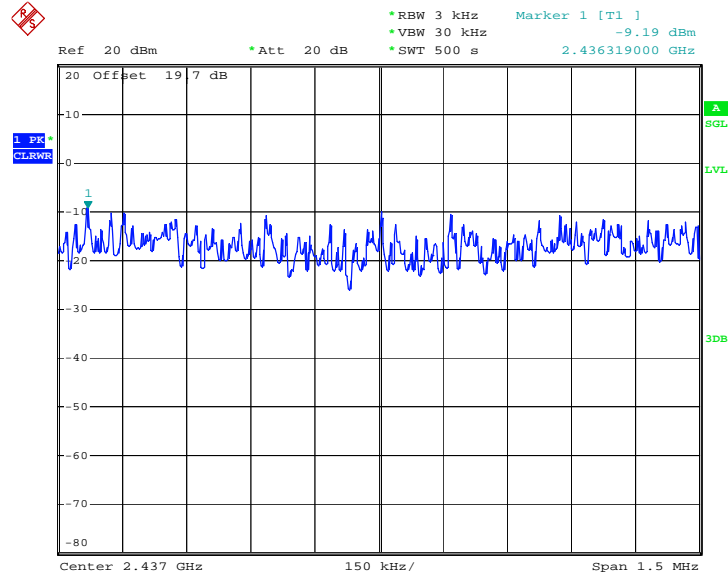

Date: 24.OCT.2008 05:56:30



Mode 3 : PSD Plot on 802.11b Channel 11

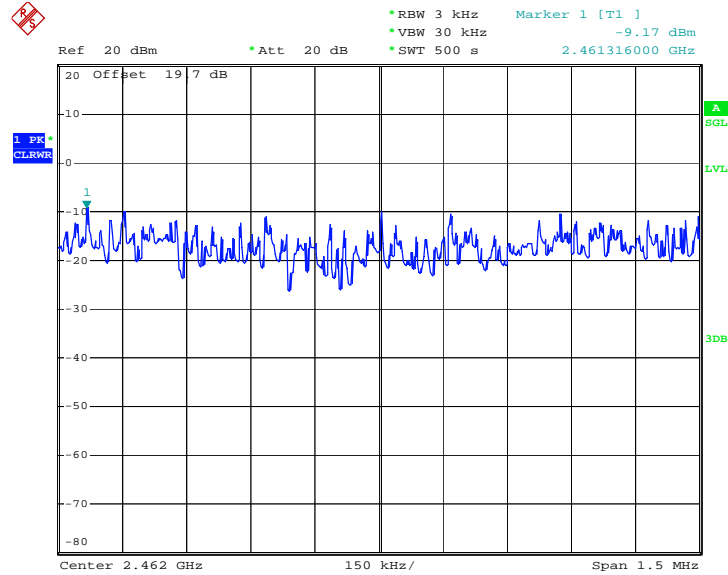

Date: 24.OCT.2008 06:05:45

Mode 4 : PSD Plot on 802.11g Channel 01

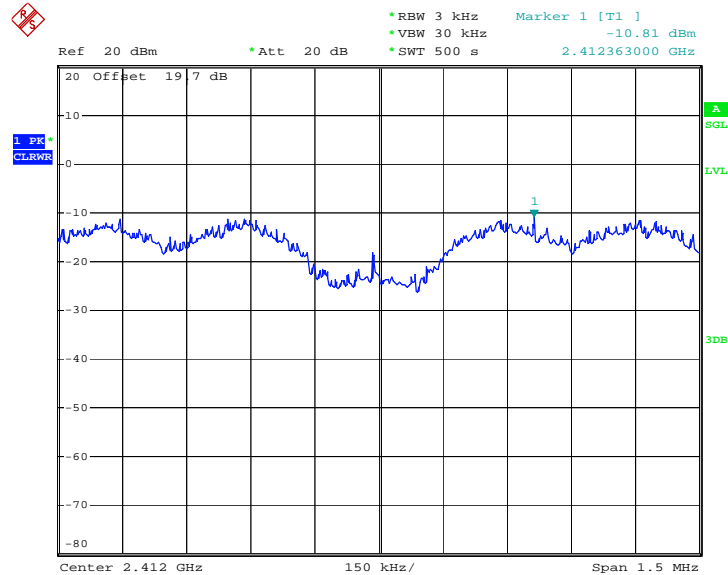

Date: 24.OCT.2008 06:32:52



Mode 5 : PSD Plot on 802.11g Channel 06

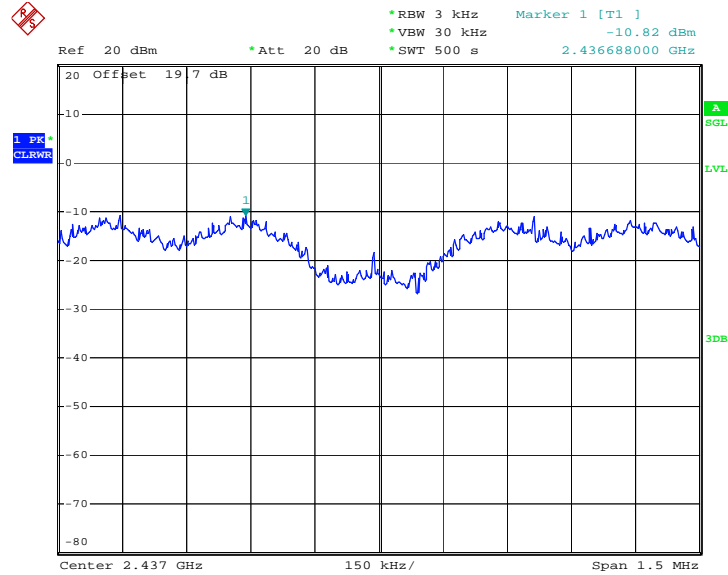

Date: 24.OCT.2008 06:23:57

Mode 6 : PSD Plot on 802.11g Channel 11

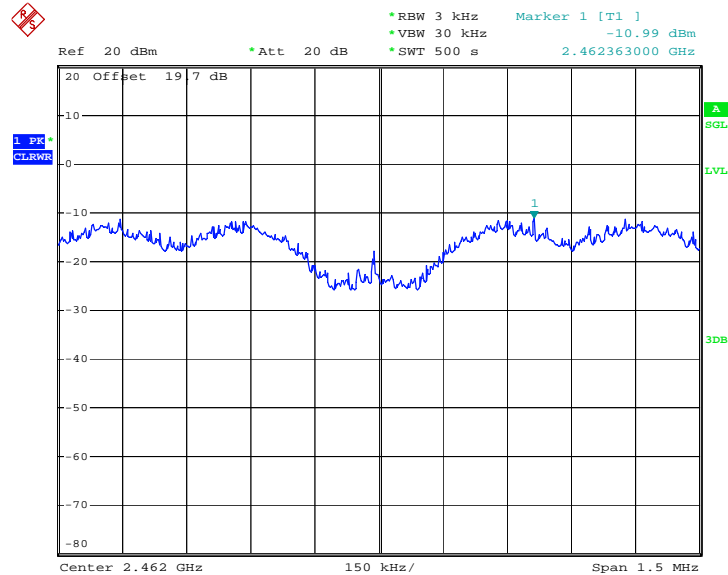

Date: 24.OCT.2008 06:14:59

3.5 AC Conducted Emission Measurement

3.5.1 Limit of AC Conducted Emission

For equipment that is designed to be connected to the public utility (AC) power line, the radio frequency voltage that is conducted back onto the AC power line on any frequency or frequencies within the band 150 kHz to 30 MHz shall not exceed the limits in the following table.

Frequency of emission (MHz)	Conducted limit (dBuV)	
	Quasi-peak	Average
0.15-0.5	66 to 56*	56 to 46*
0.5-5	56	46
5-30	60	50

*Decreases with the logarithm of the frequency.

3.5.2 Measuring Instruments

See list of measuring instruments of this test report.

3.5.3 Test Procedures

1. The testing follows the guidelines in ANSI C63.4-2003.
2. The EUT was placed 0.4 meter from the conducting wall of the shielding room, and it was kept at least 80 centimeters from any other grounded conducting surface.
3. Connect EUT to the power mains through a line impedance stabilization network (LISN).
4. All the support units are connecting to the other LISN.
5. The LISN provides 50 ohm coupling impedance for the measuring instrument.
6. The FCC states that a 50 ohm, 50 microhenry LISN should be used.
7. Both sides of AC line were checked for maximum conducted interference.
8. The frequency range from 150 kHz to 30 MHz was searched.
9. Set the test-receiver system to Peak Detect Function and specified bandwidth with Maximum Hold Mode.

3.5.4 Test Setup

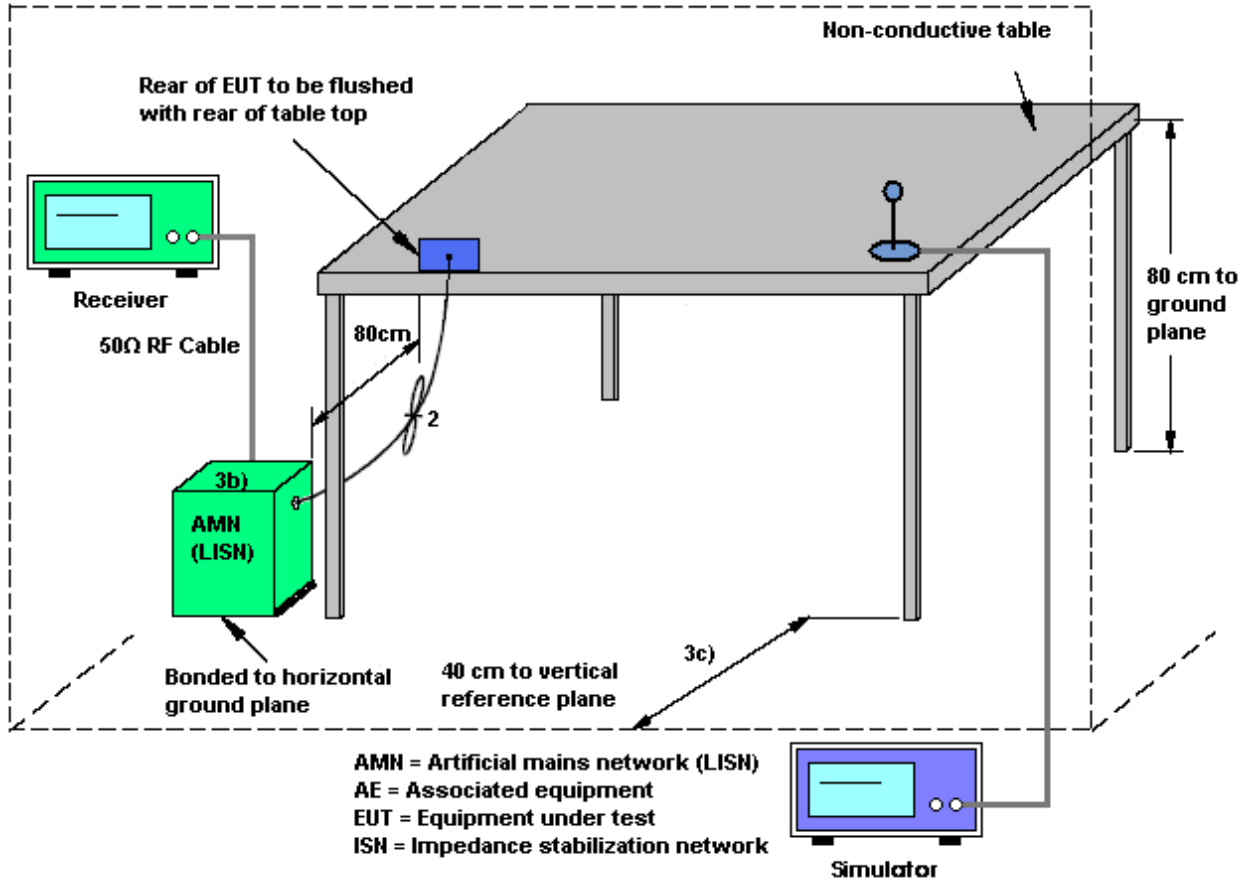

3.5.5 Test Result of AC Conducted Emission

Test Mode :	Mode 1	Temperature :	27~28°C
Test Engineer :	Cona Huang	Relative Humidity :	47~48%
		Phase :	Line
Function Type :	Sample A + WLAN Link + BT Link + Camera + TC + GPS Rx + Adapter		
Remark :	All emissions not reported here are more than 10 dB below the prescribed limit.		

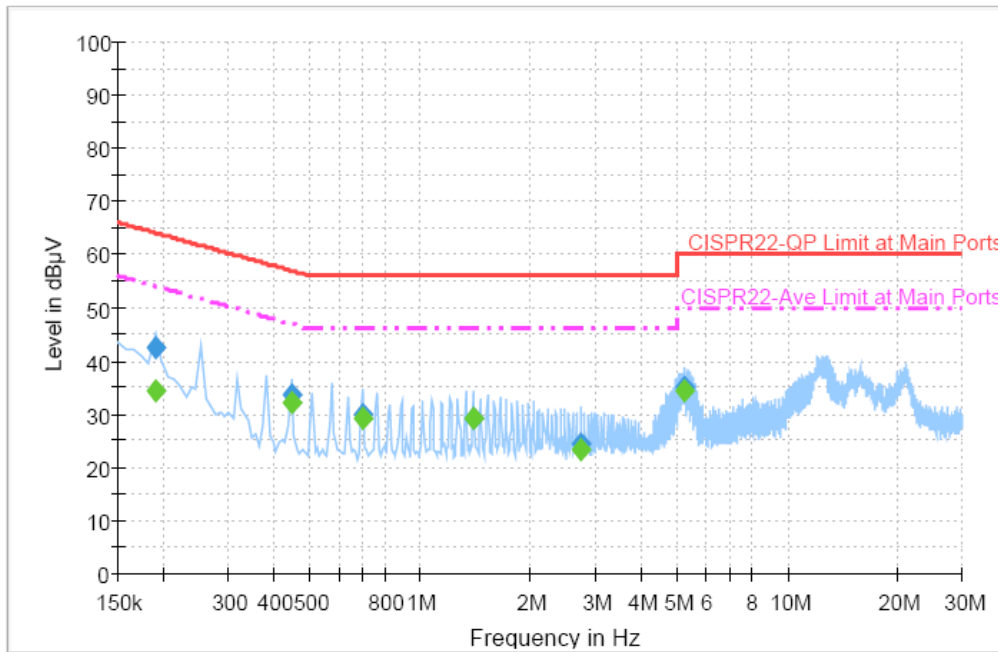

Final Result 1

Frequency (MHz)	QuasiPeak (dBµV)	Filter	Line	Corr. (dB)	Margin (dB)	Limit (dBµV)
0.190000	42.3	Off	L1	19.4	21.7	64.0
0.446000	33.4	Off	L1	19.3	23.5	56.9
0.702000	30.1	Off	L1	19.5	25.9	56.0
1.398000	29.2	Off	L1	19.4	26.8	56.0
2.734000	24.3	Off	L1	19.5	31.7	56.0
5.278000	35.0	Off	L1	19.4	25.0	60.0

Final Result 2

Frequency (MHz)	Average (dBµV)	Filter	Line	Corr. (dB)	Margin (dB)	Limit (dBµV)
0.190000	34.1	Off	L1	19.4	19.9	54.0
0.446000	32.0	Off	L1	19.3	14.9	46.9
0.702000	29.2	Off	L1	19.5	16.8	46.0
1.398000	29.1	Off	L1	19.4	16.9	46.0
2.734000	23.1	Off	L1	19.5	22.9	46.0
5.278000	34.4	Off	L1	19.4	15.6	50.0

Test Mode :	Mode 1	Temperature :	27~28°C
Test Engineer :	Cona Huang	Relative Humidity :	47~48%
		Phase :	Neutral
Function Type :	Sample A + WLAN Link + BT Link + Camera + TC + GPS Rx + Adapter		
Remark :	All emissions not reported here are more than 10 dB below the prescribed limit.		

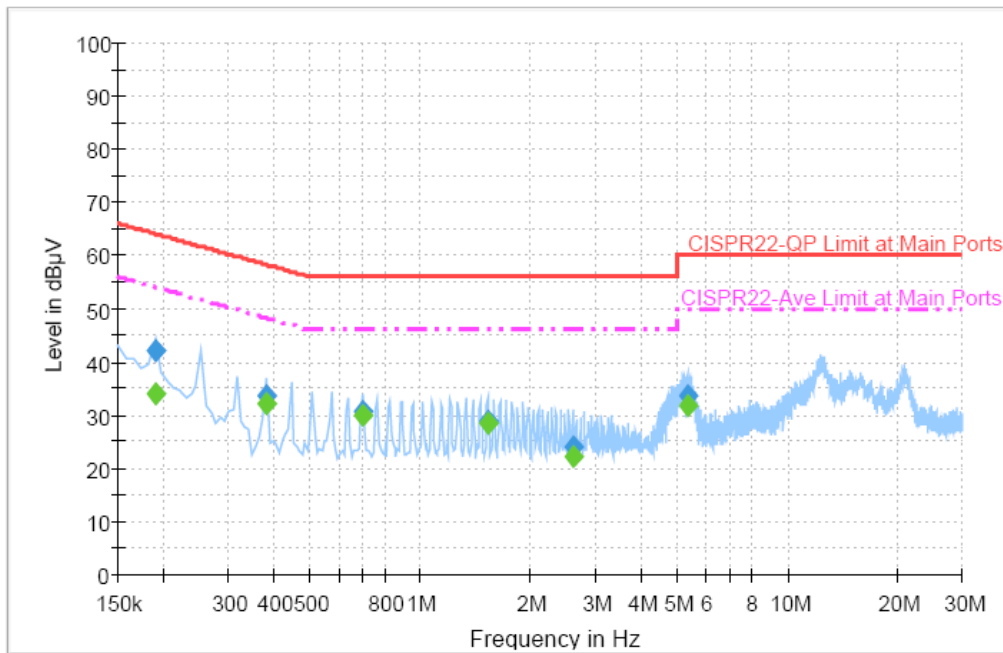

Final Result 1

Frequency (MHz)	QuasiPeak (dBµV)	Filter	Line	Corr. (dB)	Margin (dB)	Limit (dBµV)
0.190000	42.0	Off	N	19.4	22.0	64.0
0.382000	33.7	Off	N	19.4	24.5	58.2
0.702000	30.6	Off	N	19.5	25.4	56.0
1.526000	28.7	Off	N	19.4	27.3	56.0
2.606000	23.9	Off	N	19.5	32.1	56.0
5.342000	33.8	Off	N	19.5	26.2	60.0

Final Result 2

Frequency (MHz)	Average (dBµV)	Filter	Line	Corr. (dB)	Margin (dB)	Limit (dBµV)
0.190000	34.0	Off	N	19.4	20.0	54.0
0.382000	32.1	Off	N	19.4	16.1	48.2
0.702000	29.7	Off	N	19.5	16.3	46.0
1.526000	28.5	Off	N	19.4	17.5	46.0
2.606000	22.1	Off	N	19.5	23.9	46.0
5.342000	31.9	Off	N	19.5	18.1	50.0

3.6 Radiated Emission Measurement

3.6.1 Limit of Radiated Emission

In any 100 kHz bandwidth outside the intentional radiator frequency band, all harmonics/spurious must be at least 20 dB below the highest emission level within the authorized band. If the output power of this device was measured by spectrum analyzer, the attenuation under this paragraph shall be 30 dB instead of 20 dB. In addition, radiated emissions which fall in the restricted bands must also comply with the FCC section 15.209 limits as below.

Frequency (MHz)	Field Strength (microvolts/meter)	Measurement Distance (meters)
0.009 – 0.490	2400/F(kHz)	300
0.490 – 1.705	24000/F(kHz)	30
1.705 – 30.0	30	30
30 – 88	100	3
88 – 216	150	3
216 - 960	200	3
Above 960	500	3

3.6.2 Measuring Instruments

See list of measuring instruments of this test report.

3.6.3 Test Procedures

1. The testing follows the guidelines in FCC KDB Publication No. 558074 (Measurement Guidelines of DTS).
2. Use the following spectrum analyzer settings:
Span = wide enough to fully capture the emission being measured; RBW = 1 MHz for $f \geq 1$ GHz, 100 kHz for $f < 1$ GHz; VBW \geq RBW; Sweep = auto; Detector function = peak; Trace = max hold.
3. Follow the guidelines in ANSI C63.4-2003 with respect to maximizing the emission by rotating the EUT, measuring the emission for three EUT orthogonal planes, and adjusting the measurement antenna height and polarization. A pre-amp and a high pass filter are used for this test in order to get the good signal level.

3.6.4 Test Setup

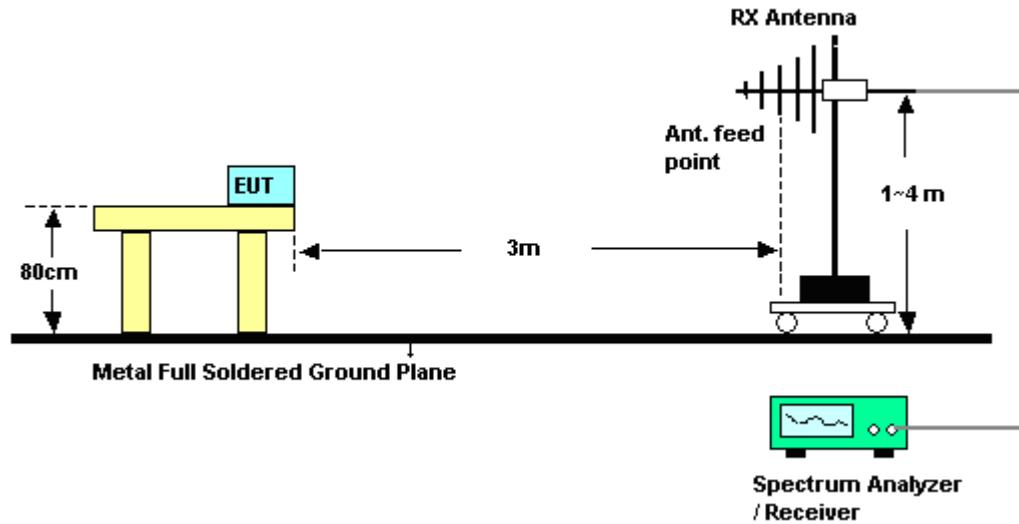



3.6.5 Test Result of Radiated Emission < 1GHz

Test Mode :	Mode 1	Temperature :	27~28°C
Test Channel :	01	Relative Humidity :	47~48%
Test Engineer :	Mac Lin and Andrew Hsiao	Polarization :	Horizontal

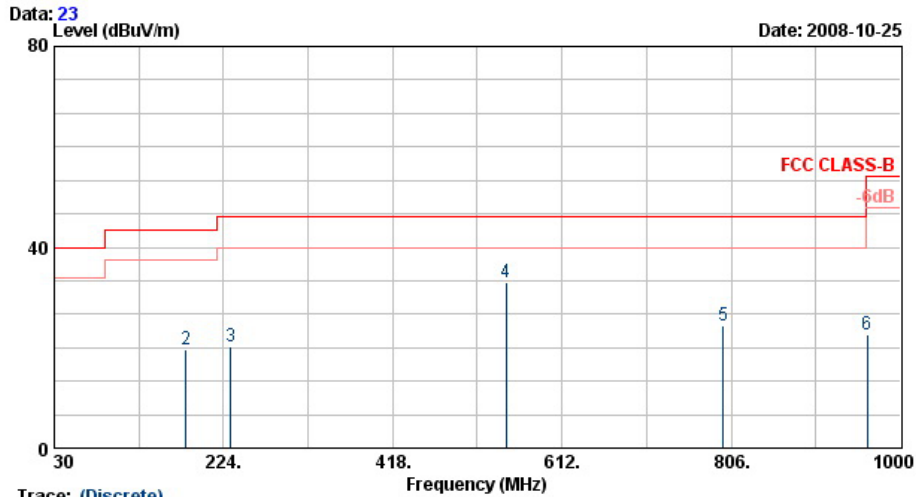

Site : 03CH06-HY
 Condition : FCC CLASS-B 3m LF-ANT(051121) HORIZONTAL
 Model : FR 800709

	Freq	Level	Over Limit	Limit Line	Read Level	Antenna Factor	Cable Loss	Preamp Factor	Ant Pos	Table Pos	Remark
	MHz	dBuV/m	dB	dBuV/m	dBuV	dB/m	dB	dB	cm	deg	
1	30.27	18.12	-21.88	40.00	29.72	19.66	0.30	31.56	---	---	Peak
2	180.66	19.50	-24.00	43.50	41.55	9.44	0.60	32.09	---	---	Peak
3	232.50	20.12	-25.88	46.00	40.14	11.24	0.70	31.97	---	---	Peak
4 @	547.80	33.09	-12.91	46.00	46.29	17.92	1.00	32.12	100	225	Peak
5	797.00	24.51	-21.49	46.00	35.69	19.79	1.20	32.17	---	---	Peak
6	962.20	22.49	-31.51	54.00	31.48	20.97	1.30	31.26	---	---	Peak



Test Mode :	Mode 1	Temperature :	27~28°C
Test Channel :	01	Relative Humidity :	47~48%
Test Engineer :	Mac Lin and Andrew Hsiao	Polarization :	Vertical

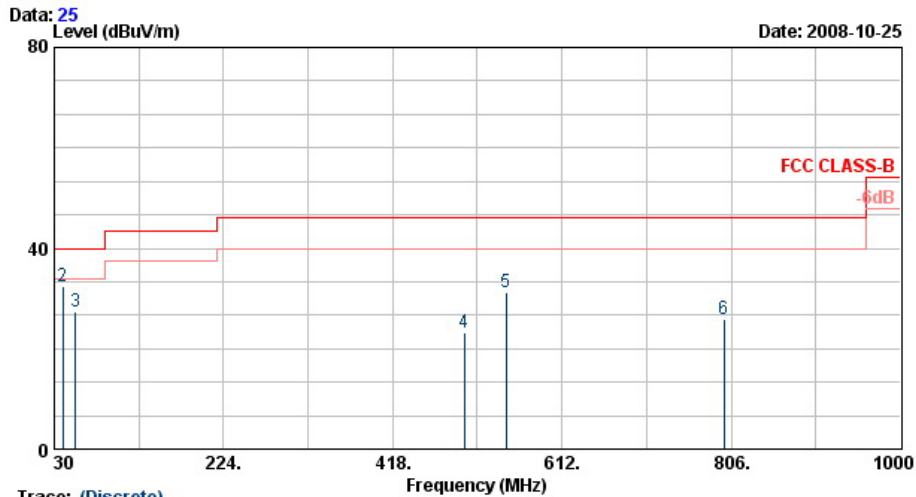

Site : 03CH06-HY
Condition : FCC CLASS-B 3m LF-ANT(051121) VERTICAL
Model : FR 800709

	Freq	Level	Over	Limit	Read	Antenna	Cable	Preamp	Ant	Table	Remark
	MHz	dBuV/m	dB	dBuV/m	dBuV	dB/m	dB	dB	cm	deg	
1 @	30.00	29.62	-10.38	40.00	41.22	19.66	0.30	31.56	---	---	Peak
2 @	39.45	32.49	-7.51	40.00	50.37	13.51	0.30	31.69	100	352	Peak
3 @	54.57	27.46	-12.54	40.00	51.51	7.50	0.38	31.92	---	---	Peak
4	500.20	23.06	-22.94	46.00	36.70	17.43	1.00	32.07	---	---	Peak
5	547.80	31.14	-14.86	46.00	44.33	17.92	1.00	32.12	---	---	Peak
6	797.70	25.97	-20.03	46.00	37.15	19.79	1.20	32.17	---	---	Peak



Test Mode :	Mode 2	Temperature :	27~28°C
Test Channel :	06	Relative Humidity :	47~48%
Test Engineer :	Mac Lin and Andrew Hsiao	Polarization :	Horizontal

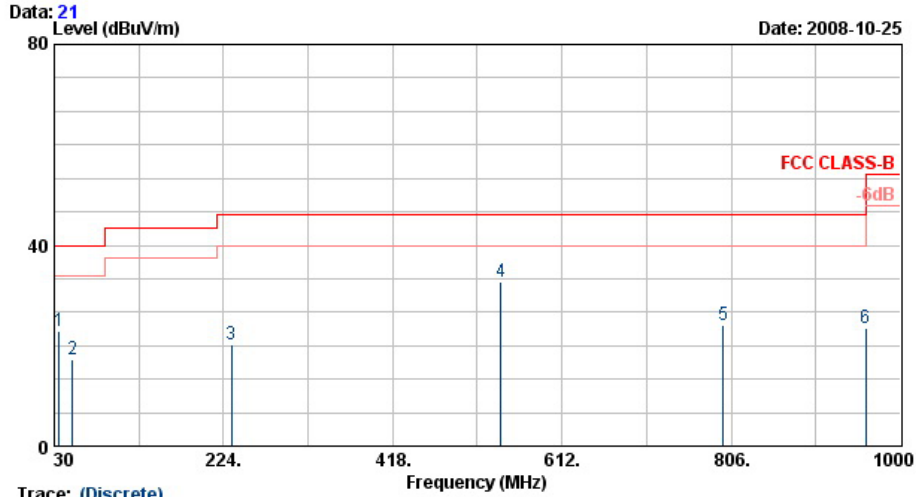

Trace: (Discrete)
 Site : 03CH06-HY
 Condition : FCC CLASS-B 3m LF-ANT(051121) HORIZONTAL
 Model : FR 800709

	Freq	Level	Over	Limit	Read	Antenna	Cable	Preamp	Ant	Table	Remark
	MHz	dBuV/m	dB	dBuV/m	dBuV	dB/m	dB	dB	cm	deg	
1	35.94	22.99	-17.01	40.00	38.89	15.61	0.30	31.80	---	---	Peak
2	51.33	17.18	-22.82	40.00	40.91	7.93	0.32	31.99	---	---	Peak
3	233.58	20.36	-25.64	46.00	40.31	11.30	0.70	31.95	---	---	Peak
4 @	542.20	32.86	-13.14	46.00	46.10	17.86	1.00	32.11	100	256	Peak
5	797.00	24.23	-21.77	46.00	35.41	19.79	1.20	32.17	---	---	Peak
6	960.10	23.45	-30.55	54.00	32.48	20.96	1.30	31.28	---	---	Peak



Test Mode :	Mode 2	Temperature :	27~28°C
Test Channel :	06	Relative Humidity :	47~48%
Test Engineer :	Mac Lin and Andrew Hsiao	Polarization :	Vertical

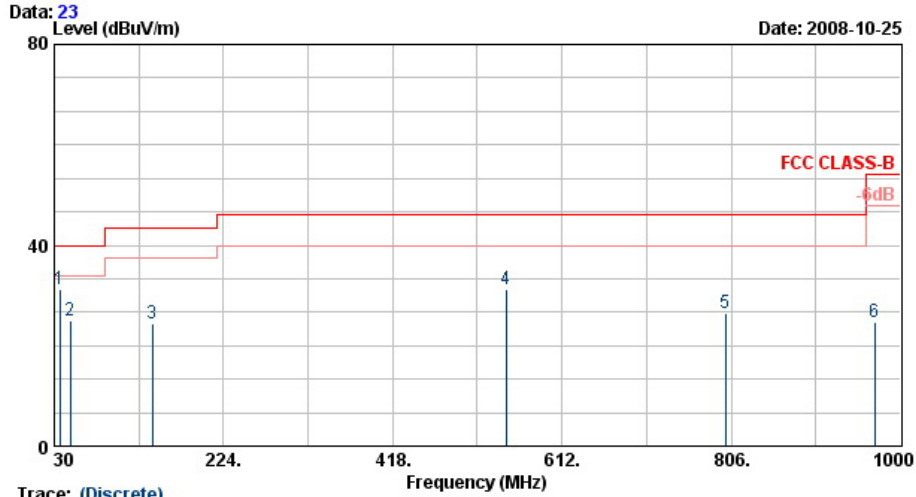

Trace: (Discrete)
 Site : 03CH06-HY
 Condition : FCC CLASS-B 3m LF-ANT(051121) VERTICAL
 Model : FR 800709

	Freq	Level	Over	Limit	Read	Antenna	Cable	Preamp	Ant	Table	Remark
	MHz	dBuV/m	Limit	Line	Level	Factor	Loss	Factor	Pos	Pos	
			dB	dBuV/m	dBuV	dB/m	dB	dB	cm	deg	
1 @	36.21	31.29	-8.71	40.00	47.19	15.61	0.30	31.80	100	352	Peak
2	48.09	24.97	-15.03	40.00	47.52	9.06	0.30	31.91	---	---	Peak
3	142.86	24.29	-19.21	43.50	45.19	10.29	0.53	31.72	---	---	Peak
4	547.80	31.16	-14.84	46.00	44.35	17.92	1.00	32.12	---	---	Peak
5	799.80	26.45	-19.55	46.00	37.61	19.82	1.20	32.18	---	---	Peak
6	970.60	24.71	-29.29	54.00	33.51	21.03	1.30	31.14	---	---	Peak



Test Mode :	Mode 3	Temperature :	27~28°C
Test Channel :	11	Relative Humidity :	47~48%
Test Engineer :	Mac Lin and Andrew Hsiao	Polarization :	Horizontal

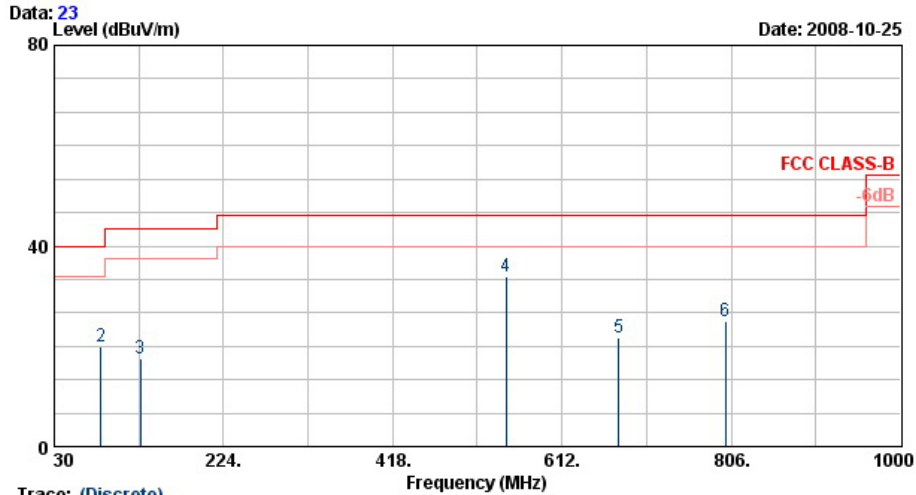

Trace: (Discrete)
Site : 03CH06-HY
Condition : FCC CLASS-B 3m LP-ANT(051121) HORIZONTAL
Model : FR 800709

	Freq	Level	Over	Limit	Read	Antenna	Cable	Preamp	Ant	Table	Remark
	MHz	dBuV/m	dB	dBuV/m	dBuV	dB/m	dB	dB	cm	deg	
1	30.81	19.80	-20.20	40.00	32.16	18.95	0.30	31.61	---	---	Peak
2	83.73	19.84	-20.16	40.00	43.48	7.97	0.44	32.05	---	---	Peak
3	129.09	17.66	-25.84	43.50	36.83	12.02	0.50	31.69	---	---	Peak
4 @	547.80	33.86	-12.14	46.00	47.05	17.92	1.00	32.12	100	226	Peak
5	677.30	21.72	-24.28	46.00	34.06	18.79	1.07	32.20	---	---	Peak
6	799.80	24.91	-21.09	46.00	36.07	19.82	1.20	32.18	---	---	Peak



Test Mode :	Mode 3	Temperature :	27~28°C
Test Channel :	11	Relative Humidity :	47~48%
Test Engineer :	Mac Lin and Andrew Hsiao	Polarization :	Vertical

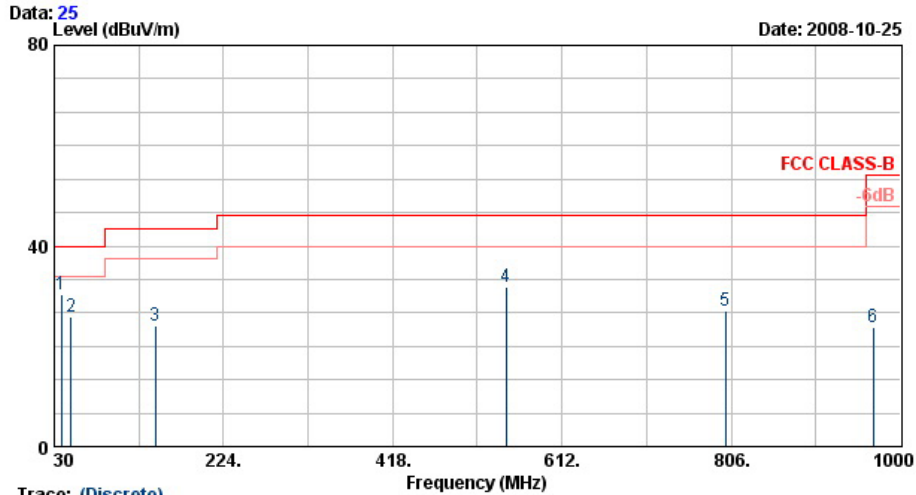

Trace: (Discrete)
 Site : 03CH06-HY
 Condition : FCC CLASS-B 3m LP-ANT(051121) VERTICAL
 Model : FR 800709

	Freq	Level	Over	Limit	Read	Antenna	Cable	Preamp	Ant	Table	
	MHz	dBuV/m	dB	dBuV/m	dBuV	dB/m	dB	dB	cm	deg	Remark
1 @	38.10	30.30	-9.70	40.00	47.19	14.56	0.30	31.75	100	325	Peak
2	48.90	25.97	-14.03	40.00	48.52	9.06	0.30	31.91	---	---	Peak
3	146.10	24.02	-19.48	43.50	44.81	10.35	0.56	31.70	---	---	Peak
4	547.80	31.87	-14.13	46.00	45.07	17.92	1.00	32.12	---	---	Peak
5	799.80	27.18	-18.82	46.00	38.34	19.82	1.20	32.18	---	---	Peak
6	968.50	23.92	-30.08	54.00	32.76	21.02	1.30	31.16	---	---	Peak



Test Mode :	Mode 4	Temperature :	27~28°C
Test Channel :	01	Relative Humidity :	47~48%
Test Engineer :	Mac Lin and Andrew Hsiao	Polarization :	Horizontal

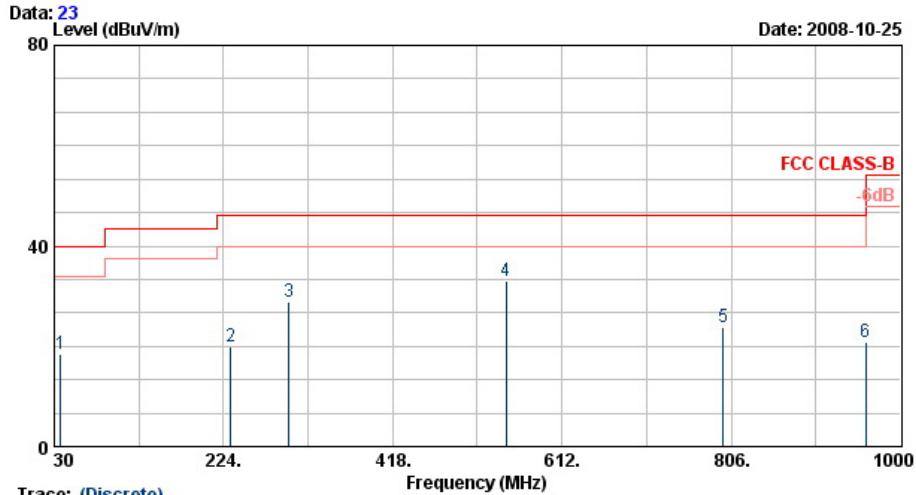

Site : 03CH06-HY
Condition : FCC CLASS-B 3m LP-ANT(951121) HORIZONTAL
Model : FR 800709

	Freq	Level	Over	Limit	Read	Antenna	Cable	Preamp	Ant	Table	Remark
	MHz	dBuV/m	dB	dBuV/m	dBuV	dB/m	dB	dB	cm	deg	
1	37.29	18.35	-21.65	40.00	35.24	14.56	0.30	31.75	---	---	Peak
2	232.50	19.95	-26.05	46.00	39.97	11.24	0.70	31.97	---	---	Peak
3	298.65	28.74	-17.26	46.00	46.99	13.19	0.70	32.14	---	---	Peak
4 @	547.80	33.06	-12.94	46.00	46.25	17.92	1.00	32.12	100	265	Peak
5	797.00	23.69	-22.31	46.00	34.87	19.79	1.20	32.17	---	---	Peak
6	960.10	20.84	-33.16	54.00	29.87	20.96	1.30	31.28	---	---	Peak



Test Mode :	Mode 4	Temperature :	27~28°C
Test Channel :	01	Relative Humidity :	47~48%
Test Engineer :	Mac Lin and Andrew Hsiao	Polarization :	Vertical

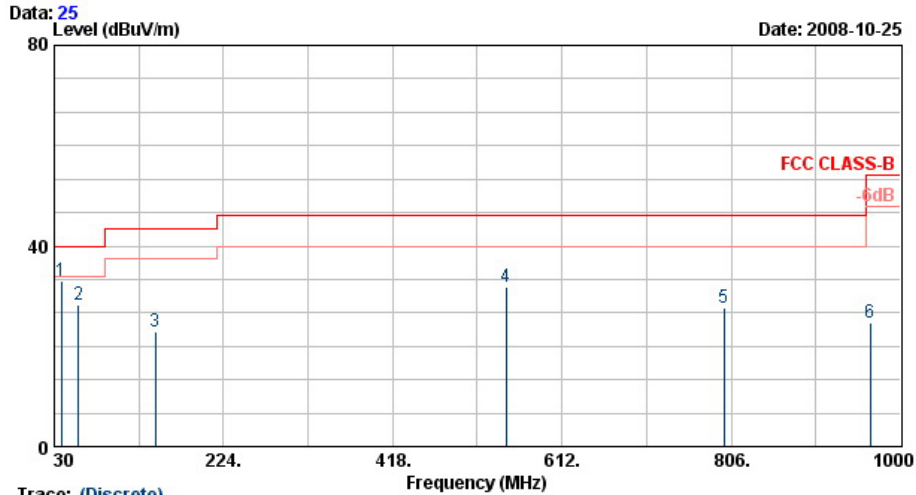

Trace: (Discrete)
Site : 03CH06-HY
Condition : FCC CLASS-B 3m LP-ANT(051121) VERTICAL
Model : FR 800709

	Freq	Level	Over	Limit	Read	Antenna	Cable	Preamp	Ant	Table	Remark
	MHz	dBuV/m	dB	dBuV/m	dBuV	dB/m	dB	dB	cm	deg	
1 @	38.37	32.94	-7.06	40.00	50.32	14.03	0.30	31.72	100	335	Peak
2 @	57.81	28.15	-11.85	40.00	52.83	6.91	0.40	31.99	---	---	Peak
3 @	146.10	23.02	-20.48	43.50	43.81	10.35	0.56	31.70	---	---	Peak
4 @	547.80	31.96	-14.04	46.00	45.15	17.92	1.00	32.12	---	---	Peak
5 @	797.70	27.70	-18.30	46.00	38.88	19.79	1.20	32.17	---	---	Peak
6 @	965.70	24.72	-29.28	54.00	33.63	21.00	1.30	31.20	---	---	Peak



Test Mode :	Mode 5	Temperature :	27~28°C
Test Channel :	01	Relative Humidity :	47~48%
Test Engineer :	Mac Lin and Andrew Hsiao	Polarization :	Horizontal

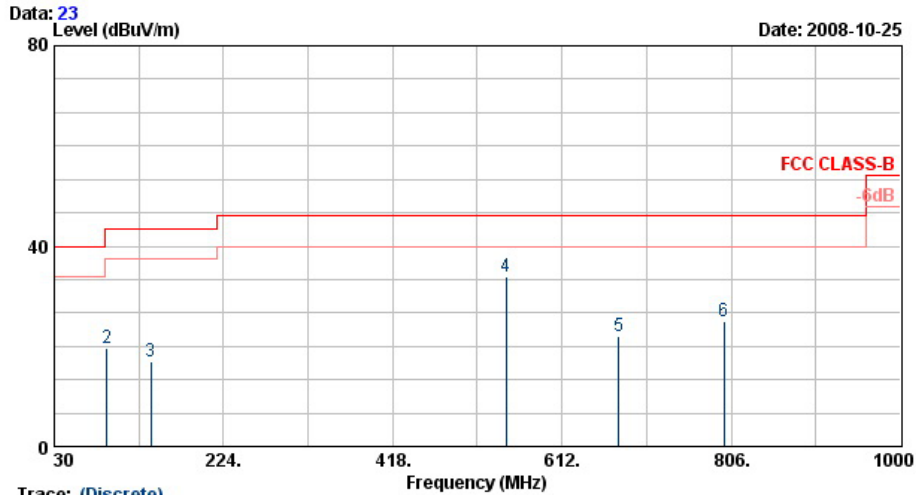

Trace: (Discrete)
 Site : 03CH06-HY
 Condition : FCC CLASS-B 3m LF-ANT(951121) HORIZONTAL
 Model : FR 800709

	Freq	Level	Over Limit	Limit Line	Read Level	Antenna Factor	Cable Loss	Preamp Factor	Ant Pos	Table Pos	Remark
	MHz	dBuV/m	dB	dBuV/m	dBuV	dB/m	dB	dB	cm	deg	
1	30.27	16.25	-23.75	40.00	27.85	19.66	0.30	31.56	---	---	Peak
2	89.94	19.70	-23.80	43.50	42.30	9.03	0.50	32.13	---	---	Peak
3	140.97	17.02	-26.48	43.50	37.98	10.26	0.51	31.73	---	---	Peak
4 @	547.80	33.81	-12.19	46.00	47.00	17.92	1.00	32.12	100	285	Peak
5	677.30	22.10	-23.90	46.00	34.44	18.79	1.07	32.20	---	---	Peak
6	797.70	24.89	-21.11	46.00	36.07	19.79	1.20	32.17	---	---	Peak



Test Mode :	Mode 5	Temperature :	27~28°C
Test Channel :	01	Relative Humidity :	47~48%
Test Engineer :	Mac Lin and Andrew Hsiao	Polarization :	Vertical

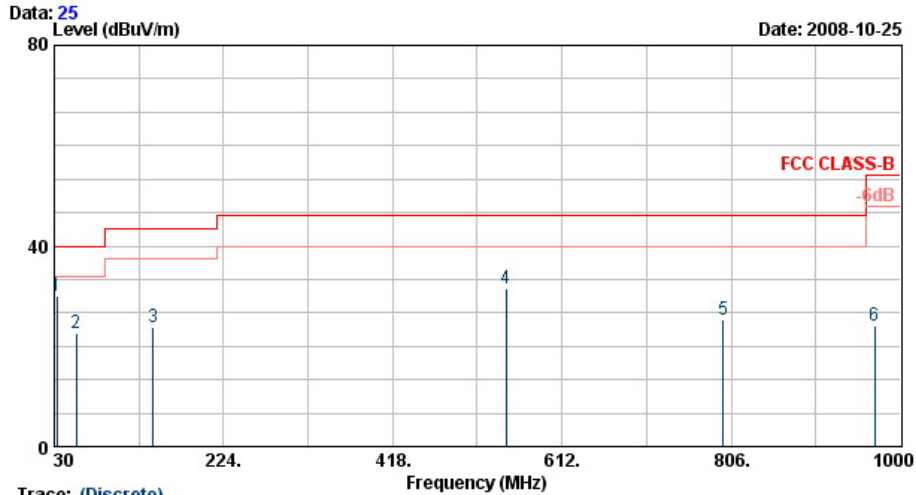

Site : 03CH06-HY
Condition : FCC CLASS-B 3m LP-ANT(051121) VERTICAL
Model : FR 800709

	Freq	Level	Over	Limit	ReadAntenna	Cable	Preamp	Ant	Table		
	MHz	dBuV/m	dB	dBuV/m	dBuV	dB/m	dB	dB	cm	deg	
1 @	32.70	30.18	-9.82	40.00	44.06	17.54	0.30	31.72	100	332	Peak
2	55.38	22.67	-17.33	40.00	46.82	7.35	0.40	31.90	---	---	Peak
3	143.13	23.67	-19.83	43.50	44.54	10.30	0.54	31.71	---	---	Peak
4	547.80	31.59	-14.41	46.00	44.79	17.92	1.00	32.12	---	---	Peak
5	797.00	25.17	-20.83	46.00	36.35	19.79	1.20	32.17	---	---	Peak
6	970.60	24.00	-30.00	54.00	32.81	21.03	1.30	31.14	---	---	Peak



Test Mode :	Mode 6	Temperature :	27~28°C
Test Channel :	06	Relative Humidity :	47~48%
Test Engineer :	Mac Lin and Andrew Hsiao	Polarization :	Horizontal

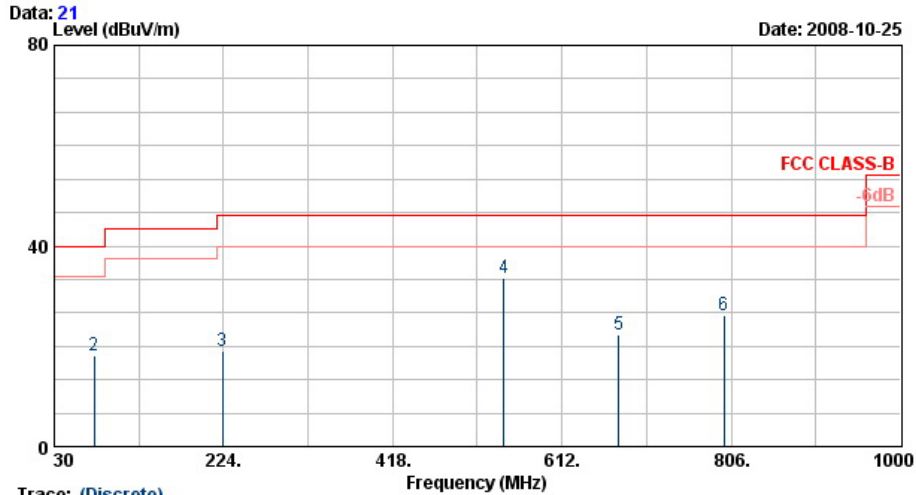

Trace: (Discrete)
Site : 03CH06-HY
Condition : FCC CLASS-B 3m LP-ANT(951121) HORIZONTAL
Model : FR 800709

	Freq	Level	Over	Limit	Read	Antenna	Cable	Preamp	Ant	Table	Remark
	MHz	dBuV/m	dB	dBuV/m	dBuV	dB/m	dB	dB	cm	deg	
1	30.54	16.85	-23.15	40.00	29.21	18.95	0.30	31.61	---	---	Peak
2	76.17	18.26	-21.74	40.00	42.42	7.29	0.43	31.88	---	---	Peak
3	223.05	19.17	-26.83	46.00	39.72	10.67	0.70	31.93	---	---	Peak
4 @	545.70	33.51	-12.49	46.00	46.72	17.90	1.00	32.12	100	256	Peak
5	677.30	22.18	-23.82	46.00	34.52	18.79	1.07	32.20	---	---	Peak
6	797.70	26.04	-19.96	46.00	37.22	19.79	1.20	32.17	---	---	Peak



Test Mode :	Mode 6	Temperature :	27~28°C
Test Channel :	06	Relative Humidity :	47~48%
Test Engineer :	Mac Lin and Andrew Hsiao	Polarization :	Vertical

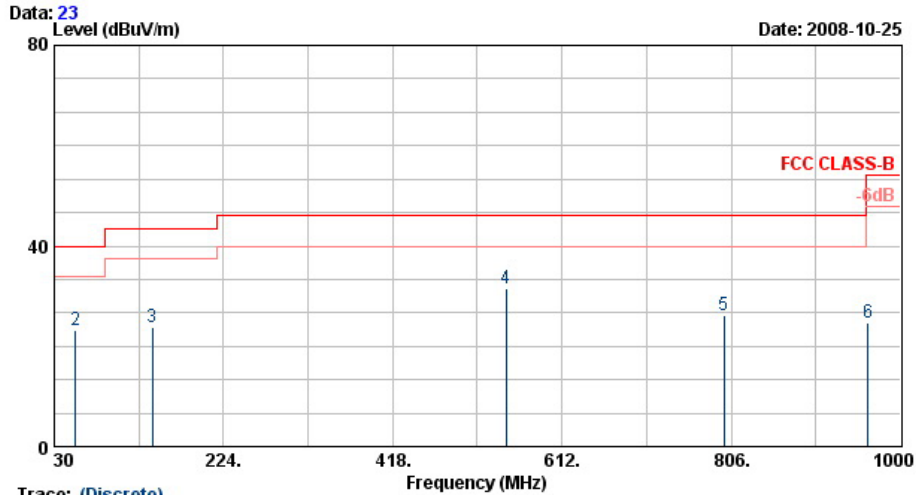

Trace: (Discrete)
Site : 03CH06-HY
Condition : FCC CLASS-B 3m LP-ANT(051121) VERTICAL
Model : FR 800709

	Freq	Level	Over	Limit	Read	Antenna	Cable	Preamp	Ant	Table	
	MHz	dBuV/m	dB	dBuV/m	dBuV	dB/m	dB	dB	cm	deg	Remark
1 @	30.00	28.79	-11.21	40.00	40.39	19.66	0.30	31.56	100	305	Peak
2	54.30	23.25	-16.75	40.00	47.29	7.50	0.38	31.92	---	---	Peak
3	142.86	23.86	-19.64	43.50	44.76	10.29	0.53	31.72	---	---	Peak
4	547.80	31.42	-14.58	46.00	44.62	17.92	1.00	32.12	---	---	Peak
5	797.70	26.31	-19.69	46.00	37.49	19.79	1.20	32.17	---	---	Peak
6	962.90	24.66	-29.34	54.00	33.62	20.98	1.30	31.24	---	---	Peak



Test Mode :	Mode 7	Temperature :	27~28°C
Test Channel :	11	Relative Humidity :	47~48%
Test Engineer :	Mac Lin and Andrew Hsiao	Polarization :	Horizontal

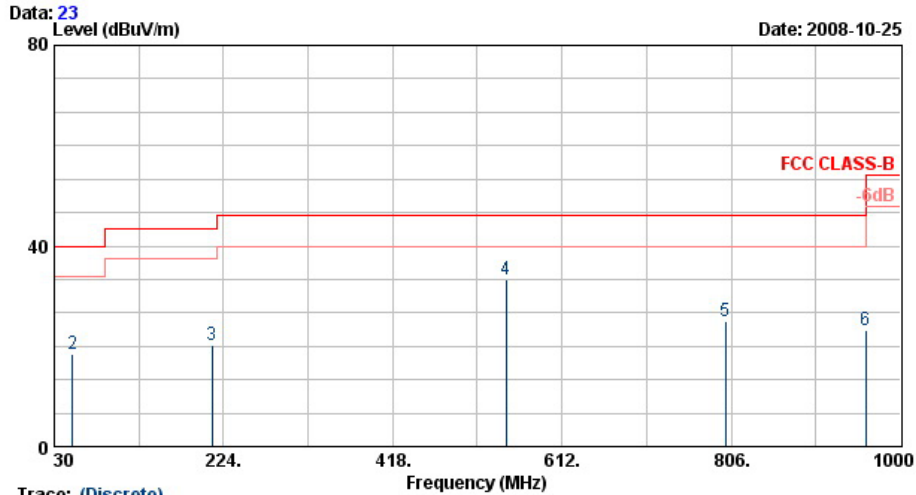

Trace: (Discrete)
Site : 03CH06-HY
Condition : FCC CLASS-B 3m LP-ANT(951121) HORIZONTAL
Model : FR 800709

	Freq	Level	Over	Limit	Read	Antenna	Cable	Preamp	Ant	Table	Remark
	MHz	dBuV/m	dB	dBuV/m	dBuV	dB/m	dB	dB	cm	deg	
1	30.81	17.50	-22.50	40.00	29.86	18.95	0.30	31.61	---	---	Peak
2	51.33	18.47	-21.53	40.00	42.20	7.93	0.32	31.99	---	---	Peak
3	210.90	20.32	-23.18	43.50	42.01	9.93	0.60	32.22	---	---	Peak
4 @	547.80	33.40	-12.60	46.00	46.59	17.92	1.00	32.12	100	257	Peak
5	799.80	24.98	-21.02	46.00	36.14	19.82	1.20	32.18	---	---	Peak
6	960.10	23.10	-30.90	54.00	32.13	20.96	1.30	31.28	---	---	Peak



Test Mode :	Mode 7	Temperature :	27~28°C
Test Channel :	11	Relative Humidity :	47~48%
Test Engineer :	Mac Lin and Andrew Hsiao	Polarization :	Vertical

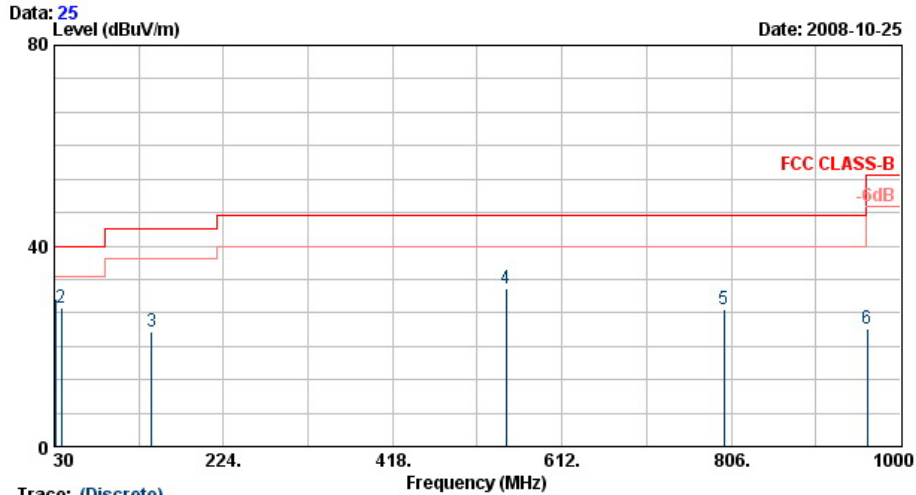

Trace: (Discrete)
Site : 03CH06-HY
Condition : FCC CLASS-B 3m LP-ANT(051121) VERTICAL
Model : FR 800709

	Freq	Level	Over	Limit	Read	Antenna	Cable	Preamp	Ant	Table	
	MHz	dBuV/m	dB	dBuV/m	dBuV	dB/m	dB	dB	cm	deg	Remark
1 @	31.62	29.54	-10.46	40.00	42.66	18.25	0.30	31.67	100	332	Peak
2 @	38.37	27.61	-12.39	40.00	45.00	14.03	0.30	31.72	---	---	Peak
3	141.78	22.76	-20.74	43.50	43.69	10.28	0.52	31.72	---	---	Peak
4	547.80	31.63	-14.37	46.00	44.82	17.92	1.00	32.12	---	---	Peak
5	797.70	27.23	-18.77	46.00	38.41	19.79	1.20	32.17	---	---	Peak
6	962.20	23.42	-30.58	54.00	32.41	20.97	1.30	31.26	---	---	Peak



Test Mode :	Mode 8	Temperature :	27~28°C
Test Channel :	01	Relative Humidity :	47~48%
Test Engineer :	Mac Lin and Andrew Hsiao	Polarization :	Horizontal

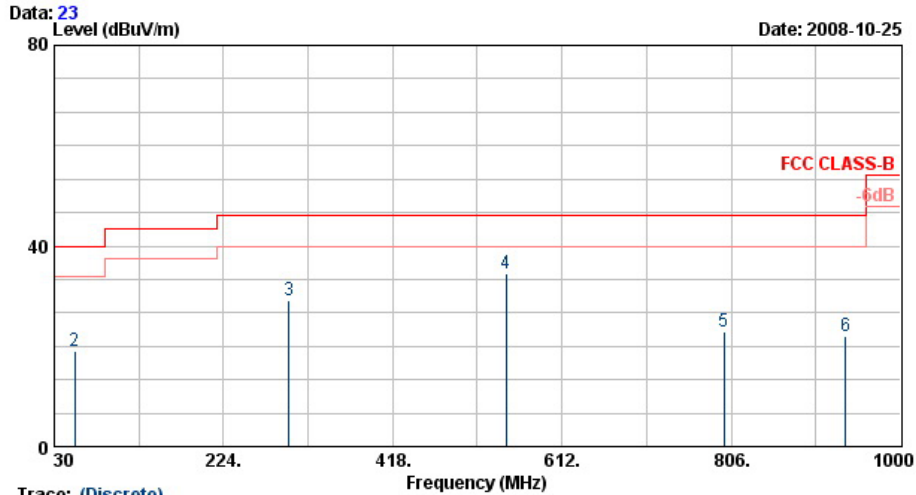

Site : 03CH06-HY
Condition : FCC CLASS-B 3m LP-ANT(951121) HORIZONTAL
Model : FR 800709

	Freq	Level	Over	Limit	ReadAntenna	Cable	Preamp	Ant	Table	Remark	
	MHz	dBuV/m	dB	dBuV/m	dBuV	dB/m	dB	dB	cm	deg	
1	30.00	23.36	-16.64	40.00	34.96	19.66	0.30	31.56	---	---	Peak
2	53.49	19.16	-20.84	40.00	43.11	7.64	0.36	31.94	---	---	Peak
3	298.65	29.20	-16.80	46.00	47.45	13.19	0.70	32.14	---	---	Peak
4 @	547.80	34.36	-11.64	46.00	47.55	17.92	1.00	32.12	100	285	Peak
5	797.70	22.97	-23.03	46.00	34.15	19.79	1.20	32.17	---	---	Peak
6	937.00	21.89	-24.11	46.00	31.39	20.79	1.20	31.49	---	---	Peak



Test Mode :	Mode 8	Temperature :	27~28°C
Test Channel :	01	Relative Humidity :	47~48%
Test Engineer :	Mac Lin and Andrew Hsiao	Polarization :	Vertical

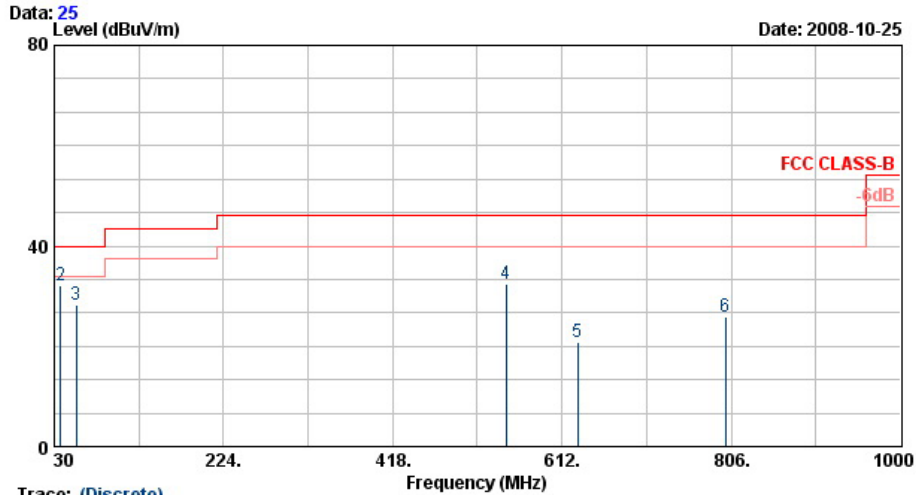

Trace: (Discrete)
Site : 03CH06-HY
Condition : FCC CLASS-B 3m LP-ANT(051121) VERTICAL
Model : FR 800709

	Freq	Level	Over	Limit	Read	Antenna	Cable	Preamp	Ant	Table	Remark
	MHz	dBuV/m	dB	dBuV/m	dBuV	dB/m	dB	dB	cm	deg	
1 @	30.81	28.60	-11.40	40.00	40.96	18.95	0.30	31.61	---	---	Peak
2 @	37.29	32.21	-7.79	40.00	49.10	14.56	0.30	31.75	100	335	Peak
3	55.38	28.28	-11.72	40.00	52.43	7.35	0.40	31.90	---	---	Peak
4	547.80	32.32	-13.68	46.00	45.51	17.92	1.00	32.12	---	---	Peak
5	629.70	20.93	-25.07	46.00	33.33	18.59	1.01	32.00	---	---	Peak
6	799.80	25.79	-20.21	46.00	36.95	19.82	1.20	32.18	---	---	Peak



3.6.6 Test Result of Radiated Emission ≥ 1 GHz

Test Mode :	Mode 1	Temperature :	27~28°C
Test Channel :	01	Relative Humidity :	47~48%
Test Engineer :	Mac Lin and Andrew Hsiao	Polarization :	Horizontal
Remark :	#3 and #4 are Fundamental Signals		

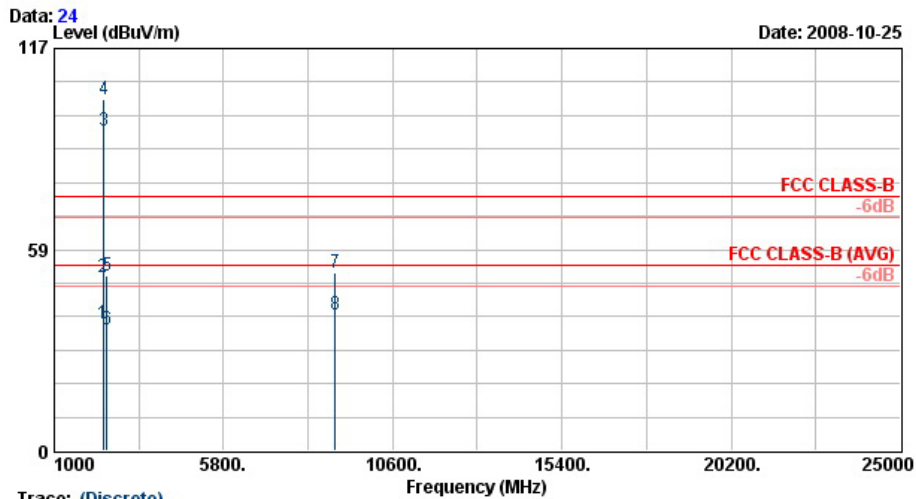

Trace: (Discrete)
 Site : 03CH06-HY
 Condition : FCC CLASS-B 3m SHF-EHF HORN HORIZONTAL
 Model : FR 800709

	Freq	Level	Over	Limit	ReadAntenna	Cable	Preamp	Ant	Table	Remark
	MHz	dBuV/m	Limit	Line	Level	Loss	Factor	Pos	Pos	
			dB	dBuV/m	dBuV	dB	dB	cm	deg	
1	2386.57	36.87	-17.13	54.00	36.65	31.98	3.92	35.68	131	44 Average
2	2386.57	50.24	-23.76	74.00	50.02	31.98	3.92	35.68	100	0 Peak
3 @	2412.00	93.28			93.01	32.00	3.95	35.68	131	44 Average
4 @	2412.00	102.06			101.79	32.00	3.95	35.68	100	0 Peak
5	2494.00	50.71	-23.29	74.00	50.26	32.10	4.05	35.70	100	0 Peak
6	2494.00	35.17	-18.83	54.00	34.72	32.10	4.05	35.70	131	44 Average
7	8973.00	51.65	-22.35	74.00	44.30	36.17	7.77	36.59	100	0 Peak
8	8973.00	39.46	-14.54	54.00	32.11	36.17	7.77	36.59	100	340 Average



Test Mode :	Mode 1	Temperature :	27~28°C
Test Channel :	01	Relative Humidity :	47~48%
Test Engineer :	Mac Lin and Andrew Hsiao	Polarization :	Vertical
Remark :	#3 and #4 are Fundamental Signals		

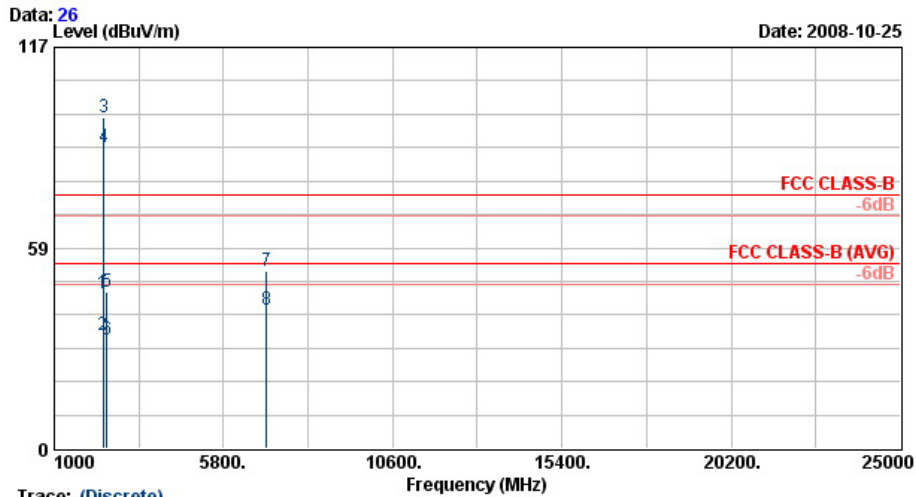

Site : 03CH06-HY
 Condition : FCC CLASS-B 3m SHF-EHF HORN VERTICAL
 Model : FR 800709

Trace: (Discrete)

	Freq	Level	Over Limit	Limit Line	Read Level	Antenna Factor	Cable Loss	Preamp Factor	Ant Pos	Table Pos	Remark
	MHz	dBuV/m	dB	dBuV/m	dBuV	dB/m	dB	dB	cm	deg	
1	2389.42	45.36	-28.64	74.00	45.14	31.98	3.92	35.68	100	0	Peak
2	2389.42	32.95	-21.05	54.00	32.73	31.98	3.92	35.68	185	53	Average
3 @	2412.00	96.46			96.19	32.00	3.95	35.68	100	0	Peak
4 @	2412.00	87.88			87.61	32.00	3.95	35.68	185	53	Average
5	2486.00	45.63	-28.37	74.00	45.19	32.08	4.05	35.70	100	0	Peak
6	2486.00	31.92	-22.08	54.00	31.49	32.08	4.05	35.70	185	53	Average
7	7017.00	51.86	-22.14	74.00	45.08	35.69	7.10	36.01	100	0	Peak
8	7017.00	40.30	-13.70	54.00	33.52	35.69	7.10	36.01	100	68	Average



Test Mode :	Mode 2	Temperature :	27~28°C
Test Channel :	06	Relative Humidity :	47~48%
Test Engineer :	Mac Lin and Andrew Hsiao	Polarization :	Horizontal
Remark :	#3 and #4 are Fundamental Signals		

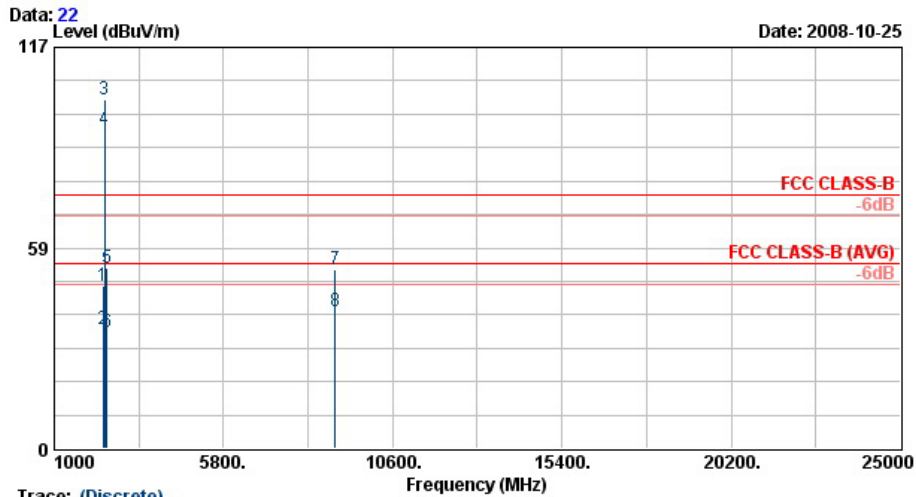

Trace: (Discrete)

Site : 03CH06-HY
 Condition : FCC CLASS-B 3m SHF-EHF HORN HORIZONTAL
 Model : FR 800709

	Freq	Level	Over Limit	Limit Line	Read Level	Antenna Factor	Cable Loss	Preamp Factor	Ant Pos	Table Pos	Remark
	MHz	dBuV/m	dB	dBuV/m	dBuV	dB/m	dB	dB	cm	deg	
1	2388.00	47.47	-26.53	74.00	47.25	31.98	3.92	35.68	100	0	Peak
2	2388.00	34.64	-19.36	54.00	34.42	31.98	3.92	35.68	128	43	Average
3 @	2437.00	101.80			101.48	32.02	3.99	35.69	100	0	Peak
4 @	2437.00	93.29			92.95	32.04	3.99	35.69	128	43	Average
5	2500.00	52.62	-21.38	74.00	52.17	32.10	4.05	35.70	100	0	Peak
6	2500.00	33.90	-20.10	54.00	33.45	32.10	4.05	35.70	128	43	Average
7	8973.00	52.14	-21.86	74.00	44.79	36.17	7.77	36.59	100	0	Peak
8	8973.00	39.94	-14.06	54.00	32.59	36.17	7.77	36.59	100	58	Average



Test Mode :	Mode 2	Temperature :	27~28°C
Test Channel :	06	Relative Humidity :	47~48%
Test Engineer :	Mac Lin and Andrew Hsiao	Polarization :	Vertical
Remark :	#3 and #4 are Fundamental Signals		

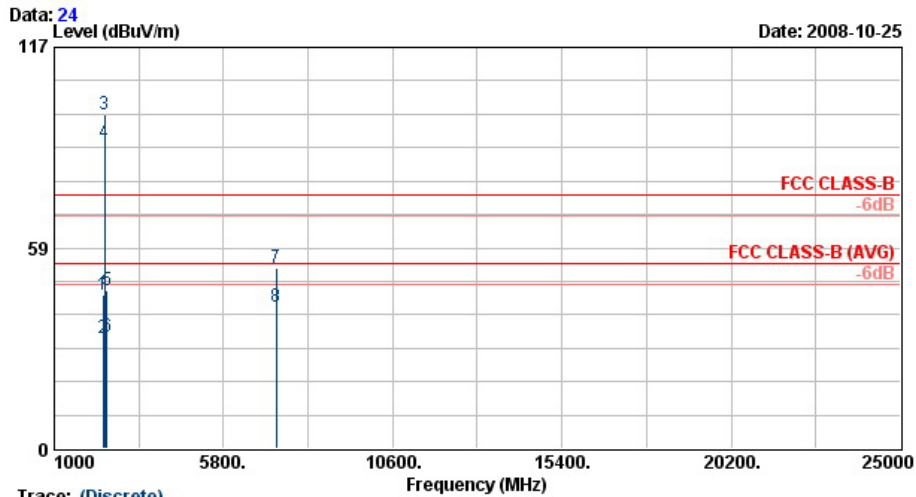

Site : 03CH06-HY
Condition : FCC CLASS-B 3m SHF-EHF HORN VERTICAL
Model : FR 800709

	Freq	Level	Over	Limit	Read	Antenna	Cable	Preamp	Ant	Table	Remark
	MHz	dBuV/m	Limit	Line	Level	Factor	Loss	Factor	Pos	Pos	
			dB	dBuV/m	dBuV	dB/m	dB	dB	cm	deg	
1	2390.00	44.68	-29.32	74.00	44.47	31.98	3.92	35.68	100	0	Peak
2	2390.00	32.14	-21.86	54.00	31.92	31.98	3.92	35.68	184	13	Average
3 @	2437.00	97.59			97.26	32.04	3.99	35.69	100	0	Peak
4 @	2437.00	89.09			88.75	32.04	3.99	35.69	184	13	Average
5	2500.00	46.06	-27.94	74.00	45.61	32.10	4.05	35.70	100	0	Peak
6	2500.00	32.43	-21.57	54.00	31.98	32.10	4.05	35.70	184	13	Average
7	7305.00	52.84	-21.16	74.00	46.18	35.58	7.20	36.12	100	0	Peak
8 @	7305.00	41.27	-12.73	54.00	34.61	35.58	7.20	36.12	100	127	Average



Test Mode :	Mode 3	Temperature :	27~28°C
Test Channel :	11	Relative Humidity :	47~48%
Test Engineer :	Mac Lin and Andrew Hsiao	Polarization :	Horizontal
Remark :	#3 and #4 are Fundamental Signals		

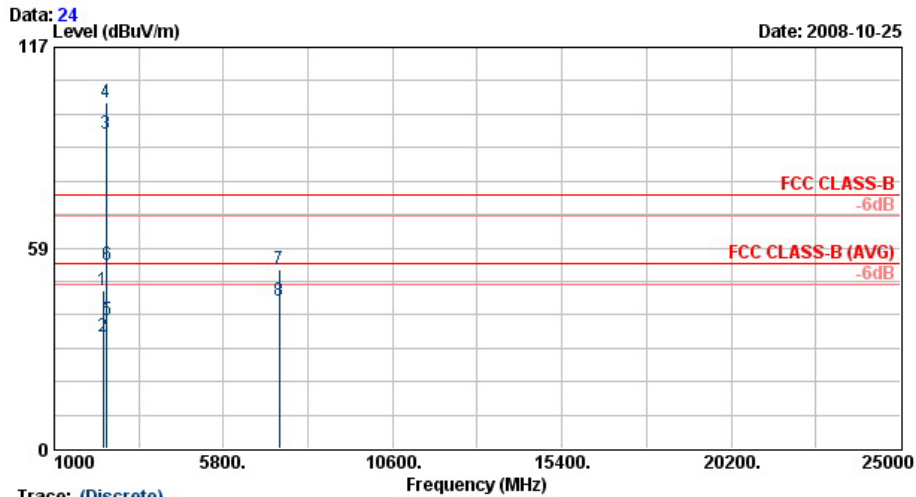

Trace: (Discrete)

Site : 03CH06-HY
 Condition : FCC CLASS-B 3m SHF-EHF HORN HORIZONTAL
 Model : FR 800709

	Freq	Level	Over Limit	Limit Line	Read Level	Antenna Factor	Cable Loss	Preamp Factor	Ant Pos	Table Pos	Remark
	MHz	dBuV/m	dB	dBuV/m	dBuV	dB/m	dB	dB	cm	deg	
1	2380.00	46.21	-27.79	74.00	46.01	31.96	3.92	35.68	100	0	Peak
2	2380.00	32.76	-21.24	54.00	32.56	31.96	3.92	35.68	128	58	Average
3 @	2462.00	91.70			91.31	32.06	4.02	35.69	128	58	Average
4 @	2462.00	100.80			100.41	32.06	4.02	35.69	100	0	Peak
5	2488.41	37.34	-16.67	54.00	36.88	32.10	4.05	35.70	128	58	Average
6	2488.41	53.61	-20.40	74.00	53.15	32.10	4.05	35.70	100	0	Peak
7	7386.00	52.38	-21.62	74.00	45.77	35.54	7.23	36.16	100	0	Peak
8 @	7386.00	43.11	-10.89	54.00	36.49	35.54	7.23	36.15	175	167	Average



Test Mode :	Mode 3	Temperature :	27~28°C
Test Channel :	11	Relative Humidity :	47~48%
Test Engineer :	Mac Lin and Andrew Hsiao	Polarization :	Vertical
Remark :	#3 and #4 are Fundamental Signals		

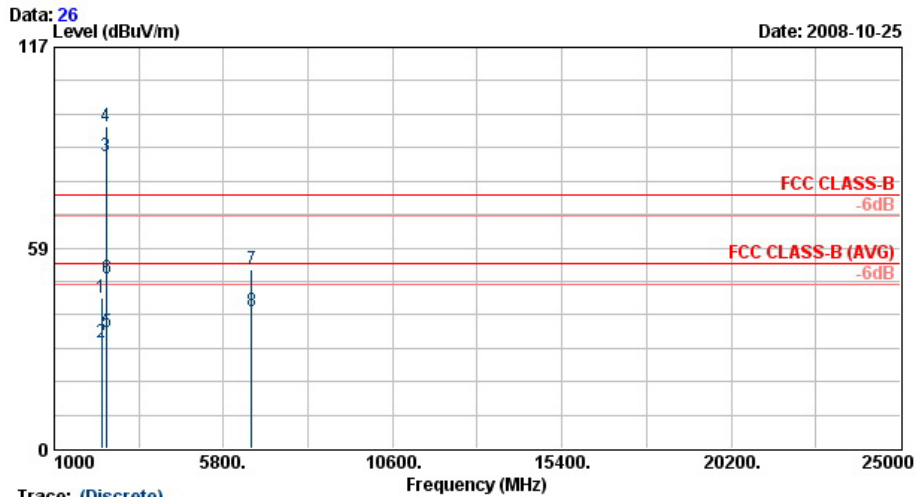

Site : 03CH06-HY
 Condition : FCC CLASS-B 3m SHF-EHF HORN VERTICAL
 Model : FR 800709

Trace: (Discrete)

	Freq	Level	Over	Limit	Read	Antenna	Cable	Preamp	Ant	Table	Remark
	MHz	dBuV/m	dB	dBuV/m	dBuV	dB/m	dB	dB	cm	deg	
1	2348.00	43.95	-30.05	74.00	43.85	31.91	3.86	35.67	100	0	Peak
2	2348.00	30.78	-23.22	54.00	30.68	31.91	3.86	35.67	100	291	Average
3 @	2462.00	85.19			84.80	32.06	4.02	35.69	100	291	Average
4 @	2462.00	94.09			93.71	32.06	4.02	35.69	100	0	Peak
5	2487.65	33.90	-20.11	54.00	33.44	32.10	4.05	35.70	100	291	Average
6	2487.65	49.63	-24.38	74.00	49.17	32.10	4.05	35.70	100	0	Peak
7	6606.00	52.04	-21.96	74.00	45.52	35.54	6.90	35.92	100	0	Peak
8	6606.00	39.89	-14.11	54.00	33.37	35.54	6.90	35.92	100	214	Average



Test Mode :	Mode 4	Temperature :	27~28°C
Test Channel :	01	Relative Humidity :	47~48%
Test Engineer :	Mac Lin and Andrew Hsiao	Polarization :	Horizontal
Remark :	#3 and #4 are Fundamental Signals		

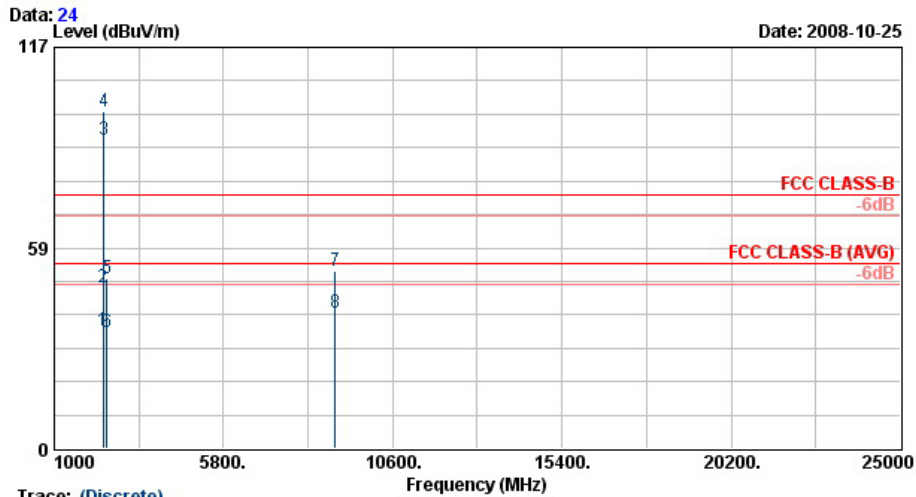

Trace: (Discrete)

Site : 03CH06-HY
 Condition : FCC CLASS-B 3m SHF-EHF HORN HORIZONTAL
 Model : FR 800709

	Freq	Level	Over Limit	Limit Line	Read Level	Antenna Factor	Cable Loss	Preamp Factor	Ant Pos	Table Pos	Remark
	MHz	dBuV/m	dB	dBuV/m	dBuV	dB/m	dB	dB	cm	deg	
1	2386.57	34.29	-19.71	54.00	34.07	31.98	3.92	35.68	129	45	Average
2	2386.57	47.02	-26.98	74.00	46.80	31.98	3.92	35.68	100	0	Peak
3 @	2412.00	89.83			89.56	32.00	3.95	35.68	129	45	Average
4 @	2412.00	98.33			98.06	32.00	3.95	35.68	100	0	Peak
5	2494.00	49.61	-24.39	74.00	49.16	32.10	4.05	35.70	100	0	Peak
6	2494.00	33.95	-20.05	54.00	33.50	32.10	4.05	35.70	129	45	Average
7	8970.00	51.93	-22.07	74.00	44.58	36.17	7.77	36.59	100	0	Peak
8	8970.00	39.63	-14.37	54.00	32.28	36.17	7.77	36.59	100	55	Average



Test Mode :	Mode 4	Temperature :	27~28°C
Test Channel :	01	Relative Humidity :	47~48%
Test Engineer :	Mac Lin and Andrew Hsiao	Polarization :	Vertical
Remark :	#3 and #4 are Fundamental Signals		

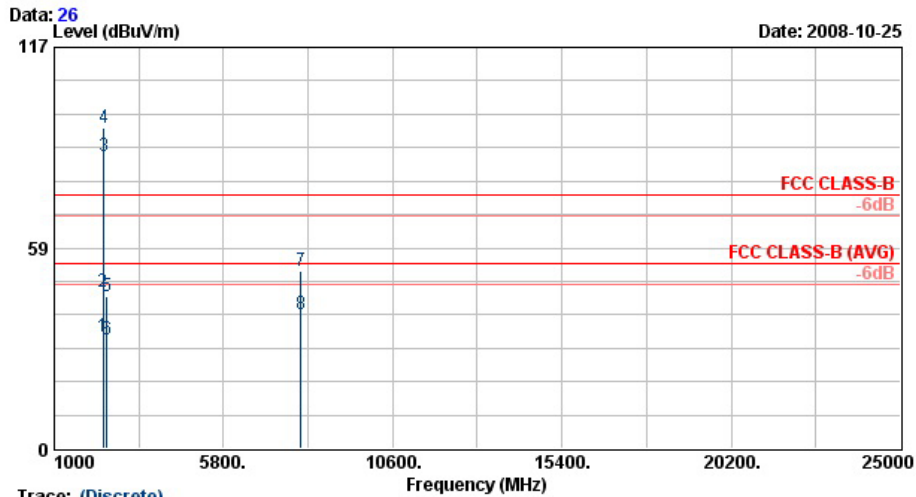

Trace: (Discrete)

Site : 03CH06-HY
Condition : FCC CLASS-B 3m SHF-EHF HORN VERTICAL
Model : FR 800709

	Freq	Level	Over Limit	Limit Line	Read Level	Antenna Factor	Cable Loss	Preamp Factor	Ant Pos	Table Pos	Remark
	MHz	dBuV/m	dB	dBuV/m	dBuV	dB/m	dB	dB	cm	deg	
1	2382.01	32.62	-21.38	54.00	32.42	31.96	3.92	35.68	135	50	Average
2	2382.01	45.56	-28.44	74.00	45.36	31.96	3.92	35.68	100	0	Peak
3 @	2412.00	85.45			85.18	32.00	3.95	35.68	135	50	Average
4 @	2412.00	93.63			93.37	32.00	3.95	35.68	100	0	Peak
5	2492.00	44.40	-29.60	74.00	43.95	32.10	4.05	35.70	100	0	Peak
6	2492.00	31.75	-22.25	54.00	31.30	32.10	4.05	35.70	135	50	Average
7	7986.00	51.55	-22.45	74.00	44.64	35.69	7.51	36.30	100	0	Peak
8	7986.00	39.25	-14.75	54.00	32.34	35.69	7.51	36.30	100	249	Average



Test Mode :	Mode 5	Temperature :	27~28°C
Test Channel :	01	Relative Humidity :	47~48%
Test Engineer :	Mac Lin and Andrew Hsiao	Polarization :	Horizontal
Remark :	#3 and #4 are Fundamental Signals		

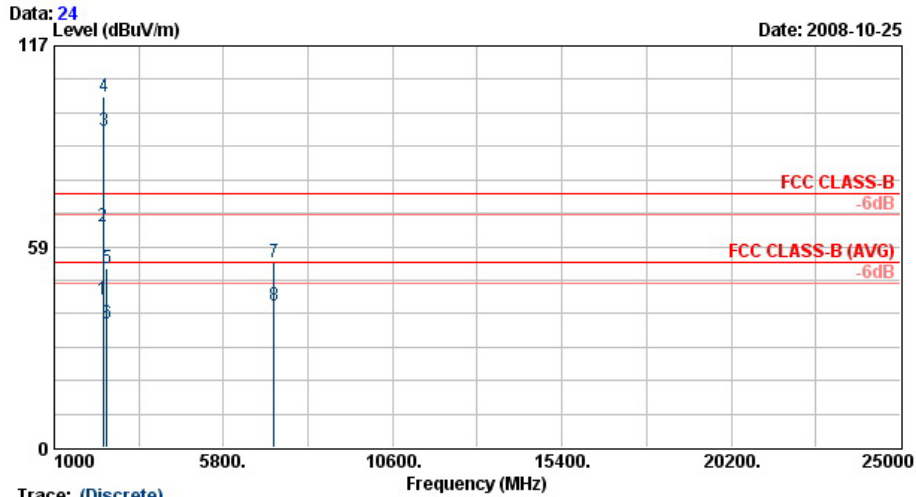

Trace: (Discrete)
 Site : 03CH06-HY
 Condition : FCC CLASS-B 3m SHF-EHF HORN HORIZONTAL
 Model : FR 800709

	Freq	Level	Over Limit	Limit Line	Read Level	Antenna Factor	Cable Loss	Preamp Factor	Ant Pos	Table Pos	Remark
	MHz	dBuV/m	dB	dBuV/m	dBuV	dB/m	dB	dB	cm	deg	
1 @	2388.85	43.05	-10.95	54.00	42.83	31.98	3.92	35.68	130	46	Average
2 @	2388.85	64.52	-9.48	74.00	64.30	31.98	3.92	35.68	100	0	Peak
3 @	2412.00	92.15			91.88	32.00	3.95	35.68	130	46	Average
4 @	2412.00	102.09			101.82	32.00	3.95	35.68	100	0	Peak
5	2494.00	52.35	-21.65	74.00	51.90	32.10	4.05	35.70	100	0	Peak
6	2494.00	36.27	-17.73	54.00	35.82	32.10	4.05	35.70	130	46	Average
7	7236.00	53.80	-20.20	74.00	47.11	35.60	7.18	36.09	100	0	Peak
8	7236.00	41.52	-12.48	54.00	34.84	35.60	7.18	36.10	168	134	Average



Test Mode :	Mode 5	Temperature :	27~28°C
Test Channel :	01	Relative Humidity :	47~48%
Test Engineer :	Mac Lin and Andrew Hsiao	Polarization :	Vertical
Remark :	#3 and #4 are Fundamental Signals		

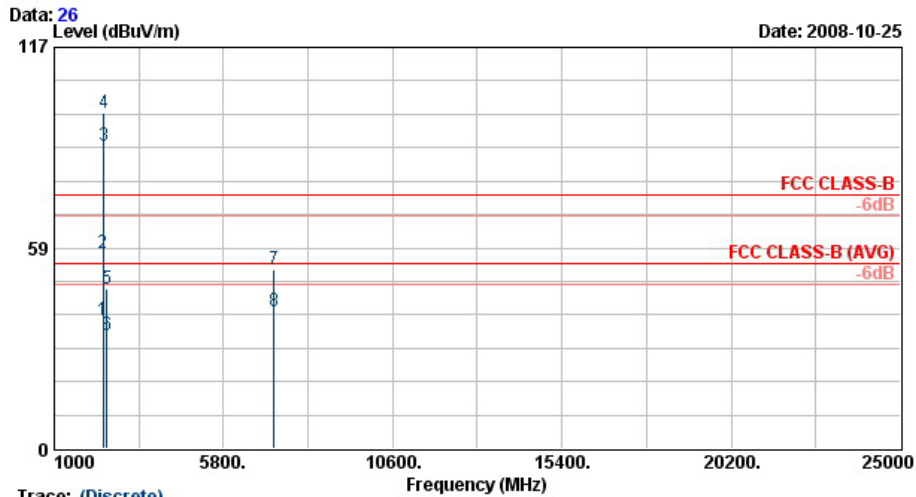

Trace: (Discrete)

Site : 03CH06-HY
Condition : FCC CLASS-B 3m SHF-EHF HORN VERTICAL
Model : FR 800709

	Freq	Level	Over	Limit	Read	Antenna	Cable	Preamp	Ant	Table	Remark
	MHz	dBuV/m	Limit	Line	Level	Factor	Loss	Factor	Pos	Pos	
			dB	dBuV/m	dBuV	dB/m	dB	dB	cm	deg	
1	2388.85	37.28	-16.72	54.00	37.06	31.98	3.92	35.68	182	26	Average
2	2388.85	56.94	-17.06	74.00	56.72	31.98	3.92	35.68	100	0	Peak
3 @	2412.00	88.20			87.93	32.00	3.95	35.68	182	26	Average
4 @	2412.00	97.95			97.71	32.00	3.92	35.68	100	0	Peak
5	2492.00	46.59	-27.41	74.00	46.14	32.10	4.05	35.70	100	0	Peak
6	2492.00	33.16	-20.84	54.00	32.71	32.10	4.05	35.70	182	26	Average
7	7236.00	52.30	-21.70	74.00	45.61	35.60	7.18	36.09	100	0	Peak
8	7236.00	40.17	-13.83	54.00	33.49	35.60	7.18	36.10	100	256	Average



Test Mode :	Mode 6	Temperature :	27~28°C
Test Channel :	06	Relative Humidity :	47~48%
Test Engineer :	Mac Lin and Andrew Hsiao	Polarization :	Horizontal
Remark :	#3 and #4 are Fundamental Signals		

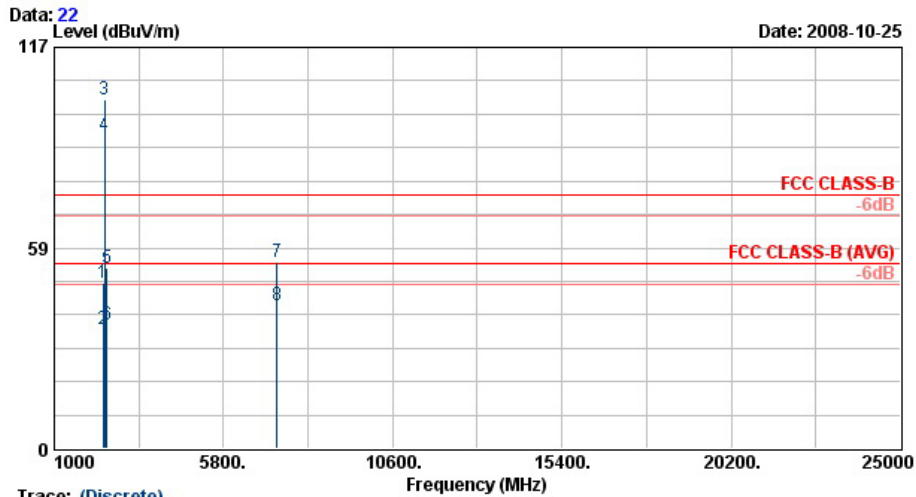

Trace: (Discrete)
Site : 03CH06-HY
Condition : FCC CLASS-B 3m SHF-EHF HORN HORIZONTAL
Model : FR 800709

	Freq	Level	Over Limit	Limit Line	Read Level	Antenna Factor	Cable Loss	Preamp Factor	Ant Pos	Table Pos	Remark
	MHz	dBuV/m	dB	dBuV/m	dBuV	dB/m	dB	dB	cm	deg	
1	2382.00	48.45	-25.55	74.00	48.25	31.96	3.92	35.68	100	0	Peak
2	2382.00	34.87	-19.13	54.00	34.67	31.96	3.92	35.68	129	43	Average
3 @	2437.00	101.68			101.37	32.02	3.99	35.69	100	0	Peak
4 @	2437.00	91.44			91.10	32.04	3.99	35.69	129	43	Average
5	2492.00	52.71	-21.29	74.00	52.26	32.10	4.05	35.70	100	0	Peak
6	2492.00	36.12	-17.88	54.00	35.67	32.10	4.05	35.70	129	43	Average
7	7311.00	54.26	-19.74	74.00	47.61	35.58	7.20	36.13	100	0	Peak
8 @	7311.00	41.75	-12.25	54.00	35.09	35.58	7.20	36.12	100	119	Average



Test Mode :	Mode 6	Temperature :	27~28°C
Test Channel :	06	Relative Humidity :	47~48%
Test Engineer :	Mac Lin and Andrew Hsiao	Polarization :	Vertical
Remark :	#3 and #4 are Fundamental Signals		

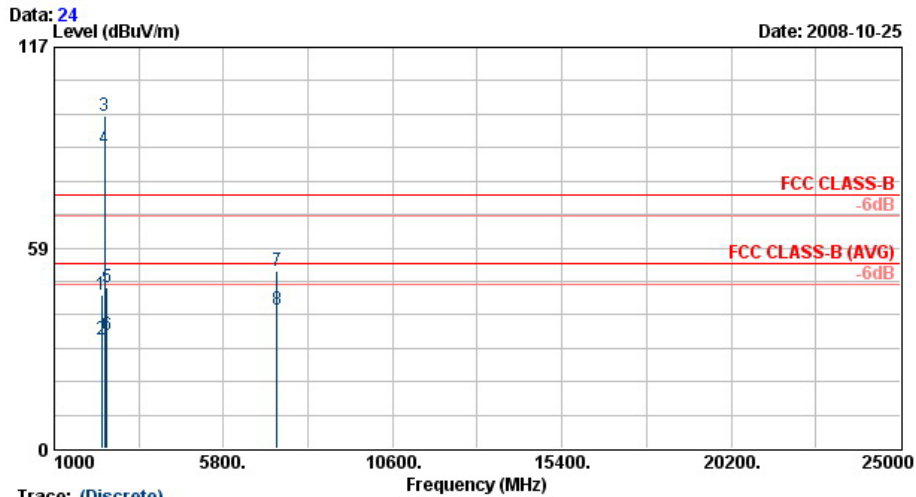

Site : 03CH06-HY
Condition : FCC CLASS-B 3m SHF-EHF HORN VERTICAL
Model : FR 800709

	Freq	Level	Over Limit	Limit Line	Read Level	Antenna Factor	Cable Loss	Preamp Factor	Ant Pos	Table Pos	Remark
	MHz	dBuV/m	dB	dBuV/m	dBuV	dB/m	dB	dB	cm	deg	
1	2350.00	44.60	-29.40	74.00	44.50	31.91	3.86	35.67	100	0	Peak
2	2350.00	31.74	-22.26	54.00	31.64	31.91	3.86	35.67	180	28	Average
3 @	2437.00	97.14			96.80	32.04	3.99	35.69	100	0	Peak
4 @	2437.00	87.22			86.88	32.04	3.99	35.69	180	28	Average
5	2492.00	47.02	-26.98	74.00	46.57	32.10	4.05	35.70	100	0	Peak
6	2492.00	33.11	-20.89	54.00	32.66	32.10	4.05	35.70	180	28	Average
7	7311.00	51.78	-22.22	74.00	45.13	35.58	7.20	36.13	100	0	Peak
8	7311.00	40.37	-13.63	54.00	33.71	35.58	7.20	36.12	100	220	Average



Test Mode :	Mode 7	Temperature :	27~28°C
Test Channel :	11	Relative Humidity :	47~48%
Test Engineer :	Mac Lin and Andrew Hsiao	Polarization :	Horizontal
Remark :	#3 and #4 are Fundamental Signals		

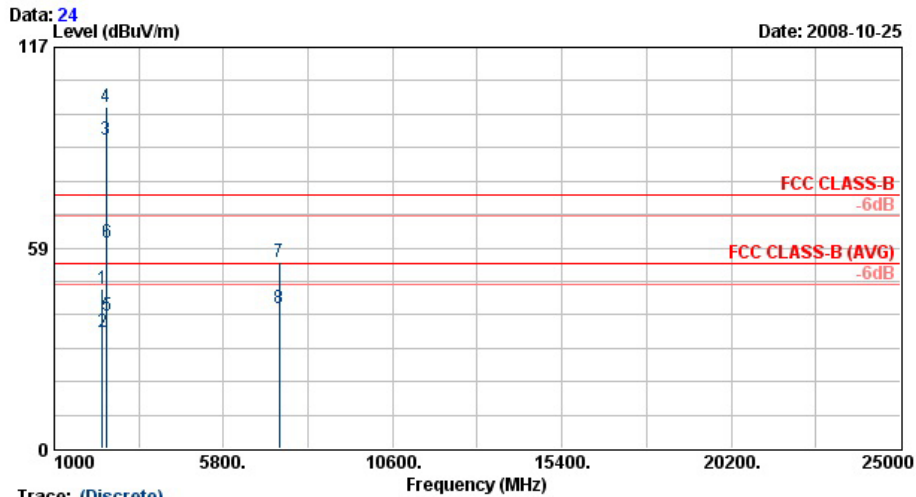

Trace: (Discrete)

Site : 03CH06-HY
Condition : FCC CLASS-B 3m SHF-EHF HORN HORIZONTAL
Model : FR 800709

	Freq	Level	Over Limit	Limit Line	Read Level	Antenna Factor	Cable Loss	Preamp Factor	Ant Pos	Table Pos	Remark
	MHz	dBuV/m	dB	dBuV/m	dBuV	dB/m	dB	dB	cm	deg	
1	2358.00	46.45	-27.55	74.00	46.30	31.93	3.89	35.67	100	0	Peak
2	2358.00	33.82	-20.18	54.00	33.67	31.93	3.89	35.67	156	42	Average
3 @	2462.00	89.89			89.50	32.06	4.02	35.69	156	42	Average
4 @	2462.00	99.74			99.35	32.06	4.02	35.69	100	0	Peak
5	2483.85	38.81	-15.19	54.00	38.38	32.08	4.05	35.70	156	42	Average
6	2483.85	60.07	-13.93	74.00	59.64	32.08	4.05	35.70	100	0	Peak
7	7386.00	54.28	-19.72	74.00	47.66	35.54	7.23	36.15	100	0	Peak
8	7386.00	40.80	-13.20	54.00	34.18	35.54	7.23	36.15	100	130	Average



Test Mode :	Mode 7	Temperature :	27~28°C
Test Channel :	11	Relative Humidity :	47~48%
Test Engineer :	Mac Lin and Andrew Hsiao	Polarization :	Vertical
Remark :	#3 and #4 are Fundamental Signals		

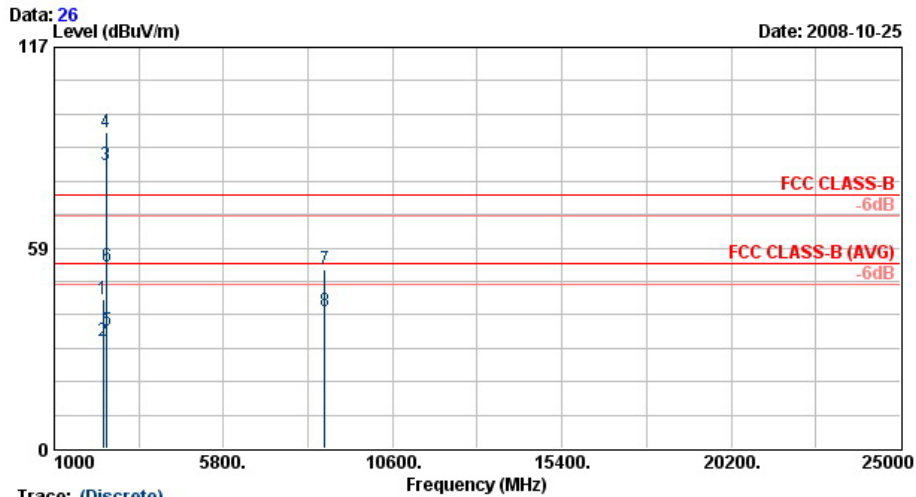

Site : 03CH06-HY
 Condition : FCC CLASS-B 3m SHF-EHF HORN VERTICAL
 Model : FR 800709

	Trace: (Discrete)	Site	Condition	Model	Freq	Level	Over Limit	Limit Line	Read Level	Antenna Factor	Cable Loss	Preamp Factor	Ant Pos	Table Pos	Remark
					MHz	dBuV/m	dB	dBuV/m	dBuV	dB/m	dB	dB	cm	deg	
1					2390.00	43.47	-30.53	74.00	43.25	31.98	3.92	35.68	100	0	Peak
2					2390.00	31.30	-22.70	54.00	31.08	31.98	3.92	35.68	100	290	Average
3 @					2462.00	82.49			82.10	32.06	4.02	35.69	100	290	Average
4 @					2462.00	92.40			92.02	32.06	4.02	35.70	100	0	Peak
5					2483.50	34.51	-19.49	54.00	34.08	32.08	4.05	35.70	100	290	Average
6					2483.50	53.11	-20.89	74.00	52.68	32.08	4.05	35.70	100	0	Peak
7					8673.00	52.30	-21.70	74.00	45.42	35.87	7.42	36.41	100	0	Peak
8					8673.00	40.16	-13.84	54.00	33.28	35.87	7.42	36.41	100	183	Average



Test Mode :	Mode 8	Temperature :	27~28°C
Test Channel :	01	Relative Humidity :	47~48%
Test Engineer :	Mac Lin and Andrew Hsiao	Polarization :	Horizontal
Remark :	#3 and #4 are Fundamental Signals		

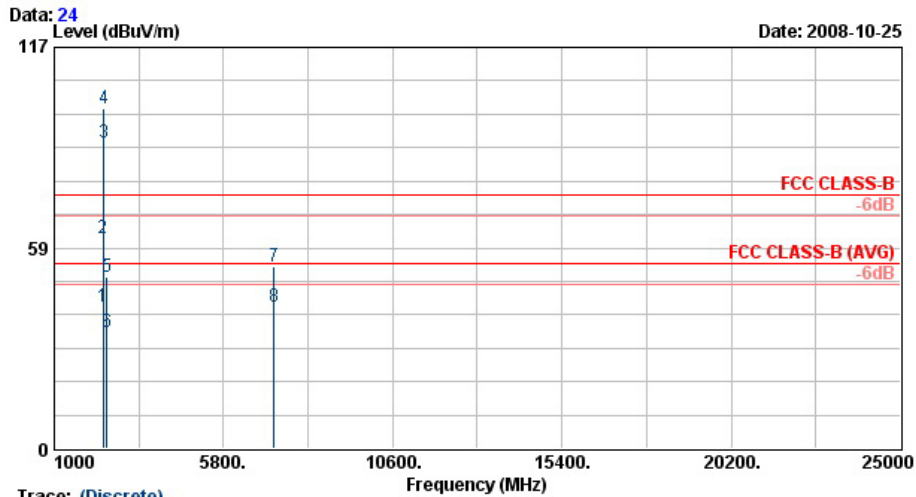

Site : 03CH06-HY
Condition : FCC CLASS-B 3m SHF-EHF HORN HORIZONTAL
Model : FR 800709

	Freq	Level	Over Limit	Limit Line	Read Level	Antenna Factor	Cable Loss	Preamp Factor	Ant Pos	Table Pos	Remark
	MHz	dBuV/m	dB	dBuV/m	dBuV	dB/m	dB	dB	cm	deg	
1	2388.85	41.32	-12.68	54.00	41.10	31.98	3.92	35.68	129	44	Average
2	2388.85	61.14	-12.86	74.00	60.92	31.98	3.92	35.68	100	0	Peak
3 @	2412.00	88.97			88.70	32.00	3.95	35.68	129	44	Average
4 @	2412.00	98.98			98.71	32.00	3.95	35.68	100	0	Peak
5	2494.00	49.88	-24.12	74.00	49.43	32.10	4.05	35.70	100	0	Peak
6	2494.00	34.07	-19.93	54.00	33.62	32.10	4.05	35.70	129	44	Average
7	7236.00	53.26	-20.74	74.00	46.57	35.60	7.18	36.09	100	0	Peak
8	7236.00	41.35	-12.65	54.00	34.67	35.60	7.18	36.10	100	67	Average



Test Mode :	Mode 8	Temperature :	27~28°C
Test Channel :	01	Relative Humidity :	47~48%
Test Engineer :	Mac Lin and Andrew Hsiao	Polarization :	Vertical
Remark :	#3 and #4 are Fundamental Signals		

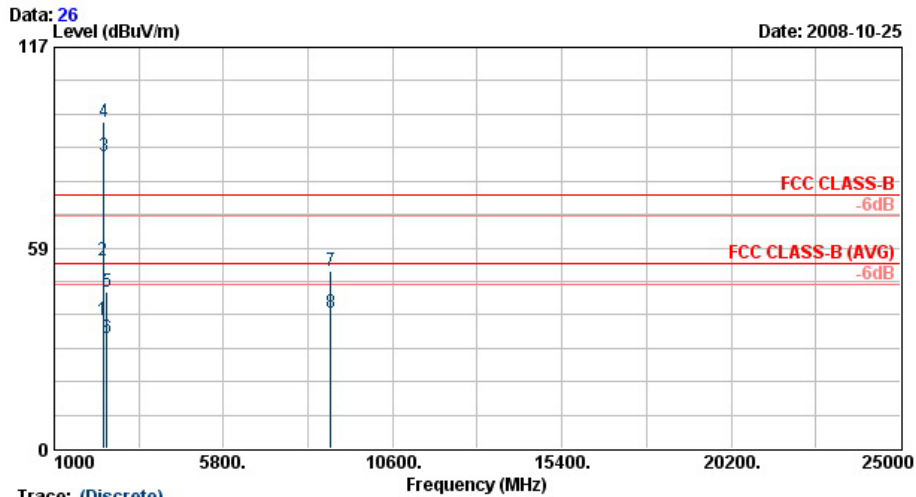

Trace: (Discrete)

Site : 03CH06-HY
 Condition : FCC CLASS-B 3m SHF-EHF HORN VERTICAL
 Model : FR 800709

	Freq	Level	Over Limit	Limit Line	Read Level	Antenna Factor	Cable Loss	Preamp Factor	Ant Pos	Table Pos	Remark
	MHz	dBuV/m	dB	dBuV/m	dBuV	dB/m	dB	dB	cm	deg	
1	2388.85	37.27	-16.73	54.00	37.05	31.98	3.92	35.68	106	43	Average
2	2388.85	54.92	-19.08	74.00	54.70	31.98	3.92	35.68	100	0	Peak
3 @	2412.00	85.30			85.03	32.00	3.95	35.68	106	43	Average
4 @	2412.00	95.18			94.95	32.00	3.92	35.68	100	0	Peak
5	2494.00	45.53	-28.47	74.00	45.08	32.10	4.05	35.70	100	0	Peak
6	2494.00	31.97	-22.03	54.00	31.52	32.10	4.05	35.70	106	43	Average
7	8841.00	51.57	-22.43	74.00	44.41	36.03	7.62	36.50	100	0	Peak
8	8841.00	39.44	-14.56	54.00	32.28	36.03	7.62	36.50	100	199	Average



3.7 Antenna Requirements

3.7.1 Standard Applicable

If directional gain of transmitting antennas is greater than 6dBi, the power shall be reduced by the same level in dB comparing to gain minus 6dBi. For the fixed point-to-point operation, the power shall be reduced by one dB for every 3 dB that the directional gain of the antenna exceeds 6 dBi.

The use of a permanently attached antenna or of an antenna that uses a unique coupling to the intentional radiator shall be considered sufficient to comply with the FCC rule.

3.7.2 Antenna Connected Construction

The antennas type used in this product is PIFA antenna without connector and it is considered to meet antenna requirement.

3.7.3 Antenna Gain

The antenna peak gain of EUT is less than 6 dBi. Therefore, it is not necessary to reduce maximum peak output power limit.

4 List of Measuring Equipments

Instrument	Manufacturer	Model No.	Serial No.	Characteristics	Calibration Date	Due Date	Remark
Spectrum Analyzer	R&S	FSP40	100055	9KHz~40GHz	Jun. 26, 2008	Jun. 25, 2009	Conducted (TH02-HY)
Power Meter	Agilent	E4416A	GB41292344	N/A	Feb. 21, 2008	Feb. 20, 2009	Conducted (TH02-HY)
Power Sensor	Agilent	E9327A	US40441548	N/A	Feb. 21, 2008	Feb. 20, 2009	Conducted (TH02-HY)
EMI Receiver	R&S	ESCS 30	100356	9kHz – 2.75GHz	Aug. 01, 2008	Jul. 31, 2009	Conduction (CO05-HY)
Two-LISN	R&S	ENV216	11-100081	9kHz – 30MHz	Dec. 06, 2007	Dec. 05, 2008	Conduction (CO05-HY)
Two-LISN	R&S	ENV216	11-100080	9kHz – 30MHz	Dec. 06, 2007	Dec. 05, 2008	Conduction (CO05-HY)
AC Power Source	APC	APC-1000W	N/A	N/A	N/A	N/A	Conduction (CO05-HY)
Spectrum Analyzer	Agilent	E4408B	MY44211030	9KHz-26.5GHz	Oct. 24, 2008	Oct. 23, 2009	Radiation (03CH06-HY)
Spectrum Analyzer	R&S	FSP40	100057	9KHz-40GHz	Oct. 16, 2008	Oct. 15, 2009	Radiation (03CH06-HY)
EMI Test Receiver	R&S	ESVS10	834468/003	20MHz-1000MHz	Apr. 24, 2008	Apr. 23, 2009	Radiation (03CH06-HY)
Bilog Antenna	SCHAFFNER	CBL6112B	2885	30MHz -2GHz	Dec. 01, 2007	Nov. 30, 2008	Radiation (03CH06-HY)
Double Ridge Horn Antenna	EMCO	3117	00066583	1G~18GHz	Aug. 18, 2008	Aug. 17, 2009	Radiation (03CH06-HY)
Double Ridge Horn Antenna	Training Research	AF-0801	95119	8G~18G	Oct. 28, 2008	Oct. 27, 2009	Radiation (03CH06-HY)
SHF-EHF Horn	SCHWARZBECK	BBHA 9170	9170-251	14G - 40GHz	Oct. 16, 2008	Oct. 15, 2009	Radiation (03CH06-HY)
Pre Amplifier	Agilent	8449B	3008A01917	1G - 26.5GHz	Nov. 22, 2007	Nov. 21, 2008	Radiation (03CH06-HY)
Pre Amplifier	Agilent	310N	186713	9KHz~1GHz	Apr. 21, 2008	Apr. 20, 2009	Radiation (03CH06-HY)

5 Uncertainty of Evaluation

Uncertainty of Conducted Emission Measurement (150kHz ~ 30MHz)

Contribution	Uncertainty of x_i		$u(x_i)$
	dB	Probability Distribution	
Receiver reading	0.10	Normal(k=2)	0.05
Cable loss	0.10	Normal(k=2)	0.05
AMN insertion loss	2.50	Rectangular	0.63
Receiver Spec	1.50	Rectangular	0.43
Site imperfection	1.39	Rectangular	0.80
Mismatch	+0.34/-0.35	U-shape	0.24
Combined standard uncertainty Uc(y)	1.13		
Measuring uncertainty for a level of confidence of 95% U=2Uc(y)	2.26		

Uncertainty of Radiated Emission Measurement (30MHz ~ 1000MHz)

Contribution	Uncertainty of x_i		$u(x_i)$
	dB	Probability Distribution	
Receiver reading	0.41	Normal(k=2)	0.21
Antenna factor calibration	0.83	Normal(k=2)	0.42
Cable loss calibration	0.25	Normal(k=2)	0.13
Pre Amplifier Gain calibration	0.27	Normal(k=2)	0.14
RCV/SPA specification	2.50	Rectangular	0.72
Antenna Factor Interpolation for Frequency	1.00	Rectangular	0.29
Site imperfection	1.43	Rectangular	0.83
Mismatch	+0.39/-0.41	U-shaped	0.28
Combined standard uncertainty Uc(y)	1.27		
Measuring uncertainty for a level of confidence of 95% U=2Uc(y)	2.54		



Uncertainty of Radiated Emission Measurement (1GHz ~ 40GHz)

Contribution	Uncertainty of x_i		$u(x_i)$	C_i	$C_i * u(x_i)$
	dB	Probability Distribution			
Receiver reading	±0.10	Normal(k=1)	0.10	1	0.10
Antenna factor calibration	±1.70	Normal(k=2)	0.85	1	0.85
Cable loss calibration	±0.50	Normal(k=2)	0.25	1	0.25
Receiver Correction	±2.00	Rectangular	1.15	1	1.15
Antenna Factor Directional	±1.50	Rectangular	0.87	1	0.87
Site imperfection	±2.80	Triangular	1.14	1	1.14
Mismatch Receiver VSWR $\Gamma_1 = 0.197$ Antenna VSWR $\Gamma_2 = 0.194$ Uncertainty = $20 \log(1 - \Gamma_1 * \Gamma_2)$	+0.34/-0.35	U-shaped	0.244	1	0.244
Combined standard uncertainty $U_c(y)$	2.36				
Measuring uncertainty for a level of confidence of 95% $U = 2U_c(y)$	4.72				

6 Certification of TAF Accreditation



Certificate No. : L1190-070110

財團法人全國認證基金會
Taiwan Accreditation Foundation

Certificate of Accreditation

This is to certify that

Sporton International Inc.
EMC & Wireless Communications Laboratory
No.52, Hwa Ya 1st Rd., Hwa Ya Technology Park, Kwei-Shan Hsiang, Tao Yuan Hsien,
Taiwan, R.O.C.

is accredited in respect of laboratory

Accreditation Criteria	: ISO/IEC 17025:2005
Accreditation Number	: 1190
Originally Accredited	: December 15, 2003
Effective Period	: January 10, 2007 to January 09, 2010
Accredited Scope	: Testing Field, see described in the Appendix Accreditation Program for Designated Testing Laboratory
Specific Accreditation Program	: for Commodities Inspection Accreditation Program for Telecommunication Equipment Testing Laboratory

Jay-San Chen

Jay-San Chen
President, Taiwan Accreditation Foundation
Date : January 10, 2007

PI, total 9 pages

The Appendix forms an integral part of this Certificate, which shall be invalid when used without the Appendix.



Appendix A. Photographs of EUT

Please refer to Sporton report number EP800709 as below.