

## U.S. Dual Band Antenna

Tyco Electronics P/N: 1513247-1



### Features

- Small and lightweight
- No tuning components
- Available in tape and reel or tray packing for automatic mounting

### Mechanical

Size	38.1 x 15.3 x 1.6 mm
Weight	1 g
Mounting	tab mounted with plated through holes

### Electrical

Frequency Range	824–894 MHz; 1850–1990 MHz
Peak Gain	0 dBi; +1dBi
VSWR	less than 2.3:1; less than 1.7:1
Polarization	linear
Power Handling	10 Watt cw
Feed Point Impedance	50 Ohms

### Legend

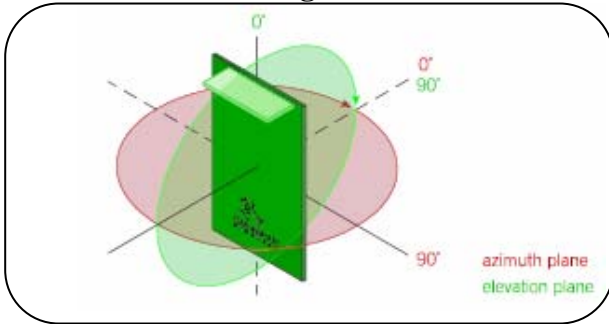

### Dimensions

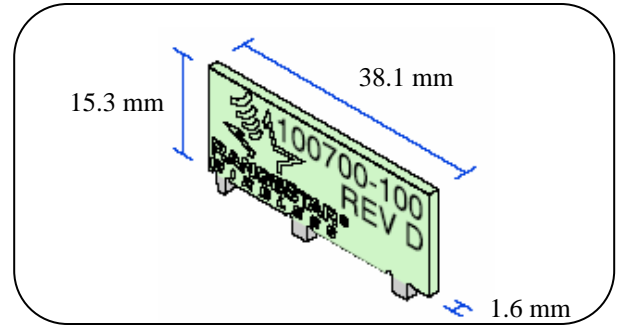

800 MHz Band (AMPS)

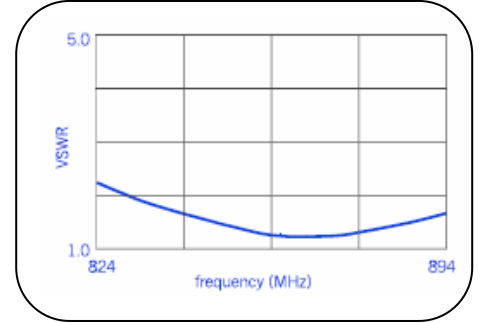
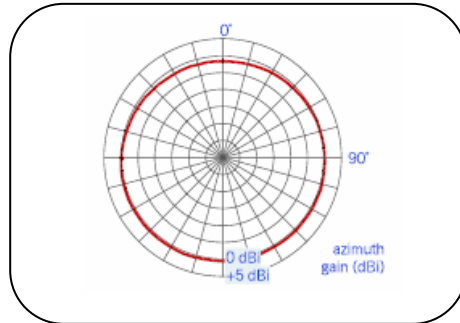
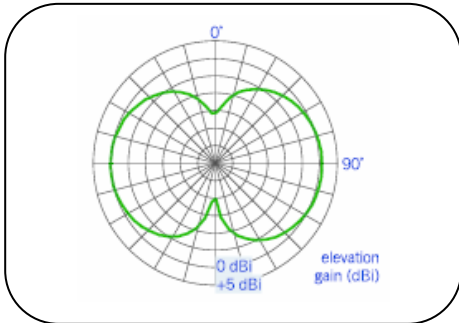

1900 MHz Band (PCS)

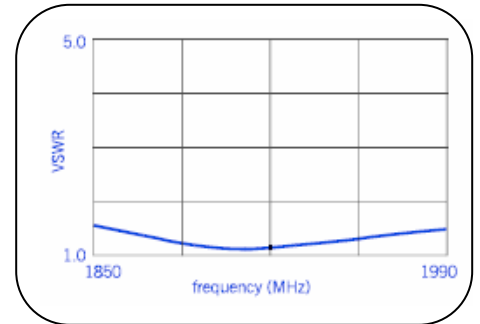
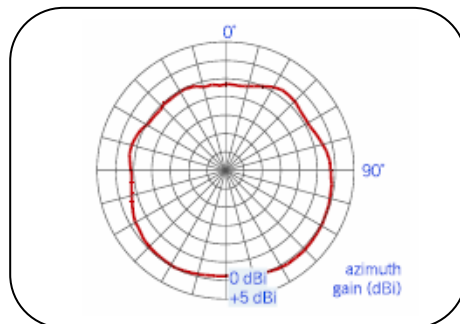
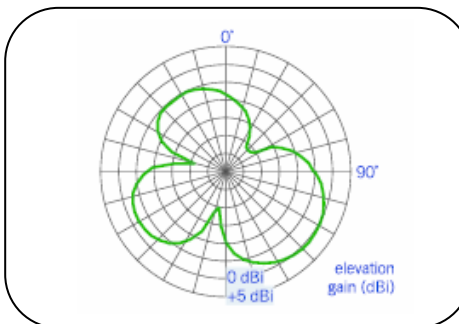



Nomad US Antenna