

## Partial FCC Test Report

### (PART 27)

**Report No.:** RF180709C05B-7

**FCC ID:** S9E-EM7455

**Test Model:** EM7455

**Received Date:** Jul. 09, 2018

**Test Date:** Aug. 02, 2018 ~ Aug. 07, 2018

**Issued Date:** Aug. 28, 2018

**Applicant:** Trimble Navigation Limited

**Address:** 345 SW Avery Ave Corvallis, Oregon, United States, 97333

**Issued By:** Bureau Veritas Consumer Products Services (H.K.) Ltd., Taoyuan Branch

**Lab Address:** No. 47-2, 14th Ling, Chia Pau Vil., Lin Kou Dist., New Taipei City, Taiwan ( R.O.C )

**Test Location (1):** No. 19, Hwa Ya 2nd Rd, Wen Hwa Vil, Kwei Shan Dist., Taoyuan City 33383, Taiwan (R.O.C)

**Test Location (2):** No.215, Sec. 3, Beixin Rd., Xindian Dist., New Taipei City 231, Taiwan, R.O.C

**FCC Registration /  
Designation Number:** 427177 / TW0011



This report is for your exclusive use. Any copying or replication of this report to or for any other person or entity, or use of our name or trademark, is permitted only with our prior written permission. This report sets forth our findings solely with respect to the test samples identified herein. The results set forth in this report are not indicative or representative of the quality or characteristics of the lot from which a test sample was taken or any similar or identical product unless specifically and expressly noted. Our report includes all of the tests requested by you and the results thereof based upon the information that you provided to us. You have 60 days from date of issuance of this report to notify us of any material error or omission caused by our negligence, provided, however, that such notice shall be in writing and shall specifically address the issue you wish to raise. A failure to raise such issue within the prescribed time shall constitute your unqualified acceptance of the completeness of this report, the tests conducted and the correctness of the report contents. Unless specific mention, the uncertainty of measurement has been explicitly taken into account to declare the compliance or non-compliance to the specification. The report must not be used by the client to claim product certification, approval, or endorsement by TAF or any government agencies

## Table of Contents

<b>Release Control Record .....</b>	<b>3</b>
<b>1 Certificate of Conformity .....</b>	<b>4</b>
<b>2 Summary of Test Results.....</b>	<b>5</b>
2.1 Measurement Uncertainty.....	7
2.2 Test Site and Instruments .....	8
<b>3 General Information .....</b>	<b>9</b>
3.1 General Description of EUT .....	9
3.2 Configuration of System under Test.....	11
3.2.1 Description of Support Units.....	11
3.3 Test Mode Applicability and Tested Channel Detail .....	12
3.4 EUT Operating Conditions .....	14
3.5 General Description of Applied Standards.....	14
<b>4 Test Types and Results .....</b>	<b>15</b>
4.1 Output Power Measurement.....	15
4.1.1 Limits of Output Power Measurement .....	15
4.1.2 Test Procedures.....	15
4.1.3 Test Setup.....	16
4.1.4 Test Results .....	17
4.2 Radiated Emission Measurement.....	25
4.2.1 Limits of Radiated Emission Measurement .....	25
4.2.2 Test Procedure .....	25
4.2.3 Deviation from Test Standard .....	25
4.2.4 Test Setup.....	26
4.2.5 Test Results .....	27
<b>5 Pictures of Test Arrangements.....</b>	<b>77</b>
<b>Appendix – Information on the Testing Laboratories .....</b>	<b>78</b>

### Release Control Record

Issue No.	Description	Date Issued
RF180709C05B-7	Original Release	Aug. 28, 2018

## 1 Certificate of Conformity

**Product:** Wireless Modules  
**Brand:** Trimble  
**Test Model:** EM7455  
**Sample Status:** Engineering Sample  
**Applicant:** Trimble Navigation Limited  
**Test Date:** Aug. 02, 2018 ~ Aug. 07, 2018  
**Standards:** FCC Part 27, Subpart C, H, F, L

The above equipment has been tested by **Bureau Veritas Consumer Products Services (H.K.) Ltd., Taoyuan Branch**, and found compliance with the requirement of the above standards. The test record, data evaluation & Equipment Under Test (EUT) configurations represented herein are true and accurate accounts of the measurements of the sample's RF characteristics under the conditions specified in this report.

**Prepared by :** , **Date:** Aug. 28, 2018  
Ivonne Wu / Supervisor

**Approved by :** , **Date:** Aug. 28, 2018  
Dylan Chiou / Project Engineer

## 2 Summary of Test Results

Applied Standard: FCC Part 27 & Part 2 (WCDMA)			
FCC Clause	Test Item	Result	Remarks
2.1046 27.50(d)(4)	Equivalent Isotropic Radiated Power	Pass	Meet the requirement of limit.
2.1047	Modulation characteristics	Pass	Meet the requirement
2.1055 27.54	Frequency Stability	N/A	Refer to Note
2.1049 27.53(h)	Occupied Bandwidth	N/A	Refer to Note
27.50(d)(5)	Peak to Average Ratio	N/A	Refer to Note
27.53(h)	Band Edge Measurements	N/A	Refer to Note
2.1051 27.53(h)	Conducted Spurious Emissions	N/A	Refer to Note
2.1053 27.53(h)	Radiated Spurious Emissions	Pass	Meet the requirement of limit. Minimum passing margin is -32.13 dB at 5257.80 MHz.

Note: Only test item of E.I.R.P. and Radiated Spurious Emissions tests were performed for this addendum. For other test data, refer to module report No.: B15W50341-FCC-RF\_Rev1.

Applied Standard: FCC Part 27 & Part 2 (LTE 4)			
FCC Clause	Test Item	Result	Remarks
2.1046 27.50(d)(4)	Maximum Peak Output Power	Pass	Meet the requirement of limit.
2.1047	Modulation characteristics	Pass	Meet the requirement
2.1055 27.54	Frequency Stability	N/A	Refer to Note
2.1049 27.53(h)	Occupied Bandwidth	N/A	Refer to Note
27.50(d)(5)	Peak to Average Ratio	N/A	Refer to Note
27.53(h)	Band Edge Measurements	N/A	Refer to Note
2.1051 27.53(h)	Conducted Spurious Emissions	N/A	Refer to Note
2.1053 27.53(h)	Radiated Spurious Emissions	Pass	Meet the requirement of limit. Minimum passing margin is -31.69 dB at 3440.00 MHz.

Note: Only test item of E.I.R.P. and Radiated Spurious Emissions tests were performed for this addendum. For other test data, refer to module report No.: B15W50341-FCC-RF\_Rev1.

<b>Applied Standard: FCC Part 27 &amp; Part 2 (LTE 12)</b>			
<b>FCC Clause</b>	<b>Test Item</b>	<b>Result</b>	<b>Remarks</b>
2.1046 27.50(c)(10)	Maximum Peak Output Power	Pass	Meet the requirement of limit.
2.1047	Modulation Characteristics	N/A	Refer to Note
2.1055 27.54	Frequency Stability	N/A	Refer to Note
2.1049 27.53(g)	Occupied Bandwidth	N/A	Refer to Note
27.50(d)(5)	Peak to Average Ratio	N/A	Refer to Note
27.53(g)	Band Edge Measurements	N/A	Refer to Note
2.1051 27.53(g)	Conducted Spurious Emissions	N/A	Refer to Note
2.1053 27.53(g)	Radiated Spurious Emissions	Pass	Meet the requirement of limit. Minimum passing margin is -31.01 dB at 2112.00 MHz.

Note: Only test item of E.R.P. and Radiated Spurious Emissions tests were performed for this addendum. For other test data, refer to module report No.: B15W50341-FCC-RF\_Rev1.

<b>Applied Standard: FCC Part 27 &amp; Part 2 (LTE 13)</b>			
<b>FCC Clause</b>	<b>Test Item</b>	<b>Result</b>	<b>Remarks</b>
2.1046 27.50(b)(10)	Maximum Peak Output Power	Pass	Meet the requirement of limit.
2.1047	Modulation Characteristics	N/A	Refer to Note
2.1055 27.54	Frequency Stability	N/A	Refer to Note
2.1049 27.53(g)	Occupied Bandwidth	N/A	Refer to Note
27.50(d)(5)	Peak to Average Ratio	N/A	Refer to Note
27.53(g)	Band Edge Measurements	N/A	Refer to Note
2.1051 27.53(g)	Conducted Spurious Emissions	N/A	Refer to Note
2.1053 27.53(g)(f)	Radiated Spurious Emissions	Pass	Meet the requirement of limit. Minimum passing margin is -8.05 dB at 1564.00 MHz.

Note: Only test item of E.R.P. and Radiated Spurious Emissions tests were performed for this addendum. For other test data, refer to module report No.: B15W50341-FCC-RF\_Rev1.

## 2.1 Measurement Uncertainty

Where relevant, the following measurement uncertainty levels have been estimated for tests performed on the EUT as specified in CISPR 16-4-2:

Measurement	Frequency	Expanded Uncertainty (k=2) ( $\pm$ )
Radiated Emissions up to 1 GHz	30 MHz ~ 200 MHz	2.0153 dB
	200 MHz ~ 1000 MHz	2.0224 dB
Radiated Emissions above 1 GHz	1 GHz ~ 18 GHz	1.0121 dB
	18 GHz ~ 40 GHz	1.1508 dB

## 2.2 Test Site and Instruments

Description & Manufacturer	Model No.	Serial No.	Date of Calibration	Due Date of Calibration
Test Receiver Agilent Technologies	N9010A	MY52220314	Nov. 24, 2017	Nov. 23, 2018
Spectrum Analyzer ROHDE & SCHWARZ	FSU43	101261	Jan. 11, 2018	Jan. 10, 2019
HORN Antenna ETS-Lindgren	3117	00143293	Dec. 13, 2017	Dec. 12, 2018
BILOG Antenna SCHWARZBECK	VULB 9168	9168-616	Dec. 14, 2017	Dec. 13, 2018
Fixed Attenuator Mini-Circuits	00801A1GGAM02Y	NA	May 17, 2018	May 16, 2019
MXG Vector signal generator Agilent	N5182B	MY53050430	Oct. 24, 2017	Oct. 23, 2018
Preamplifier Agilent	310N	187226	Jun. 19, 2018	Jun. 18, 2019
Preamplifier Agilent	83017A	MY39501357	Jun. 19, 2018	Jun. 18, 2019
RF signal cable ETS-LINDGREN	5D-FB	Cable-CH1-01(RF C-SMS-100-SMS- 120+RFC-SMS-1 00-SMS-400)	Jun. 19, 2018	Jun. 18, 2019
RF signal cable ETS-LINDGREN	8D-FB	Cable-CH1-02(RF C-SMS-100-SMS- 24)	Jun. 19, 2018	Jun. 18, 2019
Boresight Antenna Fixture	FBA-01	FBA-SIP01	NA	NA
Software BV ADT	E3 8.130425b	NA	NA	NA
Antenna Tower MF	NA	NA	NA	NA
Turn Table MF	NA	NA	NA	NA
Antenna Tower & Turn Table Controller MF	MF-7802	NA	NA	NA
Communications Tester-Wireless Agilent	8960 Series 10	MY53201073	Jun. 28, 2017	Jun. 27, 2019
Radio Communication Analyzer Anritsu	MT8820C	6201010284	Dec. 28, 2017	Dec. 27, 2018

- Note: 1. The calibration interval of the above test instruments is 12 / 24 months and the calibrations are traceable to NML/ROC and NIST/USA.
2. The test was performed in HsinTien Chamber 1.
3. The horn antenna and preamplifier (model: 83017A) are used only for the measurement of emission frequency above 1 GHz if tested.
4. The IC Site Registration No. is IC7450I-1.



### 3 General Information

#### 3.1 General Description of EUT

<b>Product</b>	Wireless Modules	
<b>Brand</b>	Trimble	
<b>Test Model</b>	EM7455	
<b>Status of EUT</b>	Engineering Sample	
<b>Power Supply Rating</b>	19 Vdc (Adapter) 7.27 Vdc (Battery)	
<b>Modulation Type</b>	WCDMA	QPSK
	LTE	QPSK, 16QAM
<b>Frequency Range</b>	WCDMA	1712.4 ~ 1752.6 MHz
	LTE Band 4 (Channel Bandwidth: 1.4 MHz)	1710.7 ~ 1754.3 MHz
	LTE Band 4 (Channel Bandwidth: 3 MHz)	1711.5 ~ 1753.5 MHz
	LTE Band 4 (Channel Bandwidth: 5 MHz)	1712.5 ~ 1752.5 MHz
	LTE Band 4 (Channel Bandwidth: 10 MHz)	1715.0 ~ 1750.0 MHz
	LTE Band 4 (Channel Bandwidth: 15 MHz)	1717.5 ~ 1747.5 MHz
	LTE Band 4 (Channel Bandwidth: 20 MHz)	1720.0 ~ 1745.0 MHz
	LTE Band 12 (Channel Bandwidth: 1.4 MHz)	699.7 ~ 715.3 MHz
	LTE Band 12 (Channel Bandwidth: 3 MHz)	700.5 ~ 714.5 MHz
	LTE Band 12 (Channel Bandwidth: 5 MHz)	701.5 ~ 713.5 MHz
	LTE Band 12 (Channel Bandwidth: 10 MHz)	704.0 ~ 711.0 MHz
	LTE Band 13 (Channel Bandwidth: 5 MHz)	779.5 ~ 784.5 MHz
	LTE Band 13 (Channel Bandwidth: 10 MHz)	782.0 MHz
<b>Max. ERP Power</b>	LTE Band 12 (Channel Bandwidth: 1.4 MHz)	221.26 mW
	LTE Band 12 (Channel Bandwidth: 3 MHz)	233.83 mW
	LTE Band 12 (Channel Bandwidth: 5 MHz)	220.34 mW
	LTE Band 12 (Channel Bandwidth: 10 MHz)	248.71 mW
	LTE Band 13 (Channel Bandwidth: 5 MHz)	177.87 mW
	LTE Band 13 (Channel Bandwidth: 10 MHz)	181.01 mW
<b>Max. EIRP Power</b>	WCDMA	288.07 mW
	LTE Band 4 (Channel Bandwidth: 1.4 MHz)	285.76 mW
	LTE Band 4 (Channel Bandwidth: 3 MHz)	307.96 mW
	LTE Band 4 (Channel Bandwidth: 5 MHz)	314.41 mW
	LTE Band 4 (Channel Bandwidth: 10 MHz)	303.88 mW
	LTE Band 4 (Channel Bandwidth: 15 MHz)	290.47 mW
	LTE Band 4 (Channel Bandwidth: 20 MHz)	318.79 mW
<b>Antenna Type</b>	Coupling Antenna	
<b>Antenna Gain</b>	WCDMA	1.04 dBi (Main) / -2.17 dBi (Aux.)
	LTE Band 4	1.04 dBi (Main) / -2.17 dBi (Aux.)
	LTE Band 12	1.33 dBi (Main) / 1.03 dBi (Aux.)
	LTE Band 13	-2.73 dBi (Main) / 0.29 dBi (Aux.)
<b>Accessory Device</b>	Refer to Note as below	
<b>Data Cable Supplied</b>	Refer to Note as below	

Note:

1. The EUT is authorized for use in specified End-product. Please refer to below for more details.

Product	Brand Name	Model Name
Handheld PC	Trimble	121600

2. The end-product contains following accessory devices.

Product	Brand	Model	Description
Adapter	DELTA Electronics, INC.	ADP-90MD H	I/P: 100-240 Vac, 50-60 Hz, 1.5 A O/P: 19 Vdc, 4.74 A 1.75m shielded cable with 1 core
Battery	Trimble	121300	7.27 Vdc, 3150 mAh, 22.9Wh
BT/WLAN Module	AzureWave	AW-CB260NF	--

3. The above EUT information is declared by manufacturer and for more detailed features description, please refers to the manufacturer's specifications or user's manual.

### 3.2 Configuration of System under Test

#### <Radiated Emission Test>

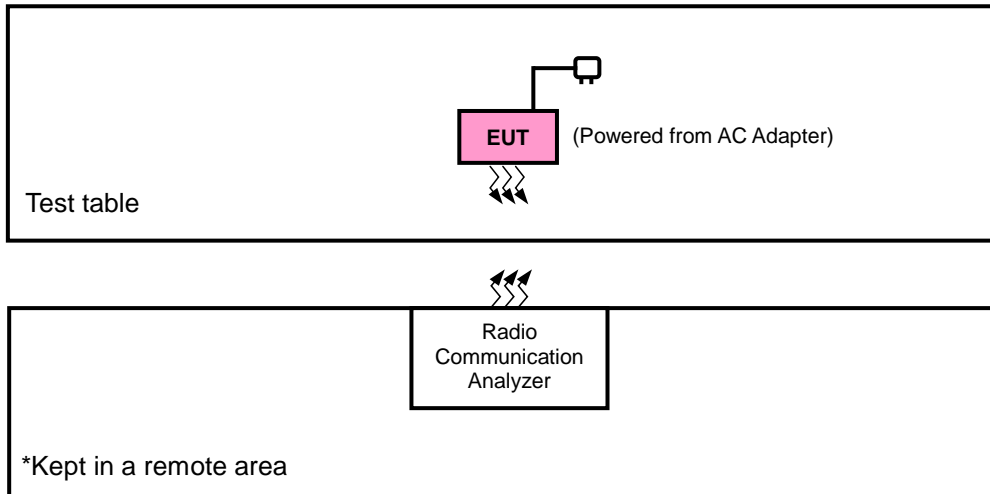

#### <E.R.P. / E.I.R.P. Test>

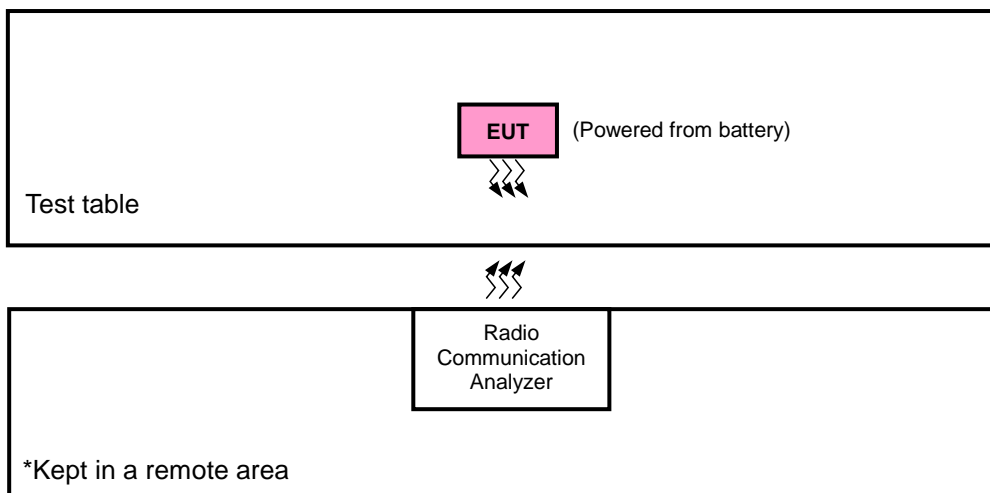

#### 3.2.1 Description of Support Units

The EUT has been tested as an independent unit together with other necessary accessories or support units.

### 3.3 Test Mode Applicability and Tested Channel Detail

Pre-Scan has been conducted to determine the worst-case mode from all possible combinations between available modulations, data rates, XYZ axis, and antenna ports

The worst case was found when positioned as the table below. Following channel(s) was (were) selected for the final test as listed below:

Band	ERP / EIRP	Radiated Emission
WCDMA	X-plane	X-axis
LTE Band 4	X-plane	Z-axis
LTE Band 12	Z-plane	X-axis
LTE Band 13	X-plane	Y-axis

#### WCDMA

EUT Configure Mode	Test Item	Available Channel	Tested Channel	Mode
-	EIRP	1312 to 1513	1312, 1413, 1513	WCDMA
-	Radiated Emission	1312 to 1513	1312, 1413, 1513	WCDMA

#### LTE Band 4

EUT Configure Mode	Test Item	Available Channel	Tested Channel	Channel Bandwidth	Modulation	Mode
-	EIRP	19957 to 20393	19957, 20175, 20393	1.4 MHz	QPSK, 16QAM	1 RB / 0 RB Offset
		19965 to 20385	19965, 20175, 20385	3 MHz	QPSK, 16QAM	1 RB / 0 RB Offset
		19975 to 20375	19975, 20175, 20375	5 MHz	QPSK, 16QAM	1 RB / 0 RB Offset
		20000 to 20350	20000, 20175, 20350	10 MHz	QPSK, 16QAM	1 RB / 0 RB Offset
		20025 to 20325	20025, 20175, 20325	15 MHz	QPSK, 16QAM	1 RB / 0 RB Offset
		20050 to 20300	20050, 20175, 20300	20 MHz	QPSK, 16QAM	1 RB / 0 RB Offset
-	Radiated Emission	19957 to 20393	19957, 20175, 20393	1.4 MHz	QPSK	1 RB / 0 RB Offset
		19975 to 20375	19975, 20175, 20375	5 MHz	QPSK	1 RB / 0 RB Offset
		20050 to 20300	20050, 20175, 20300	20 MHz	QPSK	1 RB / 0 RB Offset

**Note:** This device was tested under all bandwidths, RB configurations and modulations. The worst case was found in QPSK modulation.

### LTE Band 12

EUT Configure Mode	Test Item	Available Channel	Tested Channel	Channel Bandwidth	Modulation	Mode
-	ERP	23017 to 23173	23017, 23095, 23173	1.4 MHz	QPSK, 16QAM	1 RB / 0 RB Offset
		23025 to 23165	23025, 23095, 23165	3 MHz	QPSK, 16QAM	1 RB / 0 RB Offset
		23035 to 23155	23035, 23095, 23155	5 MHz	QPSK, 16QAM	1 RB / 0 RB Offset
		23060 to 23130	23060, 23095, 23130	10 MHz	QPSK, 16QAM	1 RB / 0 RB Offset
-	Radiated Emission	23017 to 23173	23017, 23095, 23173	1.4 MHz	QPSK	1 RB / 0 RB Offset
		23035 to 23155	23035, 23095, 23155	5 MHz	QPSK	1 RB / 0 RB Offset
		23060 to 23130	23060, 23095, 23130	10 MHz	QPSK	1 RB / 0 RB Offset

**Note:** This device was tested under all bandwidths, RB configurations and modulations. The worst case was found in QPSK modulation.

### LTE Band 13

EUT Configure Mode	Test Item	Available Channel	Tested Channel	Channel Bandwidth	Modulation	Mode
-	ERP	23205 to 23255	23205, 23230, 23255	5 MHz	QPSK, 16QAM	1 RB / 0 RB Offset
		23230	23230	10 MHz	QPSK, 16QAM	1 RB / 0 RB Offset
-	Radiated Emission	23205 to 23255	23205, 23230, 23255	5 MHz	QPSK	1 RB / 0 RB Offset
		23230	23230	10 MHz	QPSK	1 RB / 0 RB Offset

**Note:** This device was tested under all bandwidths, RB configurations and modulations. The worst case was found in QPSK modulation.

### Test Condition:

Test Item	Environmental Conditions	Input Power	Tested By
ERP / EIRP	25 deg. C, 65 % RH	120 Vac, 60 Hz	Karl Lee
Radiated Emission	25 deg. C, 65 % RH	120 Vac, 60 Hz	Karl Lee

### **3.4 EUT Operating Conditions**

The EUT makes a call to the communication simulator. The communication simulator station system controlled a EUT to export maximum output power under transmission mode and specific channel frequency

### **3.5 General Description of Applied Standards**

The EUT is a RF Product. According to the specifications of the manufacturer, it must comply with the requirements of the following standards:

**FCC 47 CFR Part 2**

**FCC 47 CFR Part 27**

**KDB 971168 D01 Power Meas License Digital Systems v03r01**

**ANSI/TIA/EIA-603-E 2016**

**ANSI 63.26-2015**

**Note:** All test items have been performed and recorded as per the above standards.

## 4 Test Types and Results

### 4.1 Output Power Measurement

#### 4.1.1 Limits of Output Power Measurement

Fixed, mobile, and portable (hand-held) stations operating in the 1710–1755 MHz band are limited to 1 watt EIRP.

Portable stations (hand-held devices) operating in the 698-787 MHz band are limited to 3 watts ERP

#### 4.1.2 Test Procedures

##### **EIRP / ERP Measurement:**

- a. All measurements were done at low, middle and high operational frequency range. RBW and VBW is 5 MHz for WCDMA and 10 MHz for LTE mode.
- b. Substitution method is used for E.I.R.P measurement. In the semi-anechoic chamber, EUT placed on the 0.8 m (below or equal 1 GHz) and/or 1.5 m (above 1 GHz) height of Turn Table, rotated the table around 360 degrees to search the maximum radiation power and receiver antenna shall be rotated vertical and horizontal polarization and moved height from 1 m to 4 m to find the maximum polar radiated power. The “Read Value” is the spectrum reading the maximum power value.
- c. The substitution horn antenna is substituted for EUT at the same position and signals generator export the CW signal to the substitution antenna via a tx cable. Rotated the Turn Table and moved receiving antenna to find the maximum radiation power. Adjust output power level of S.G to get a Value of spectrum reading equal to “Read Value” of step b. Record the power level of S.G.
- d.  $EIRP = \text{Output power level of S.G} - \text{TX cable loss} + \text{Antenna gain of substitution horn}$ . E.R.P power can be calculated form E.I.R.P power by subtracting the gain of dipole,  $E.R.P \text{ power} = E.I.R.P \text{ power} - 2.15 \text{ dB}$ .

4.1.3 Test Setup

**EIRP / ERP Measurement:**

**<Radiated Emission below or equal 1 GHz>**

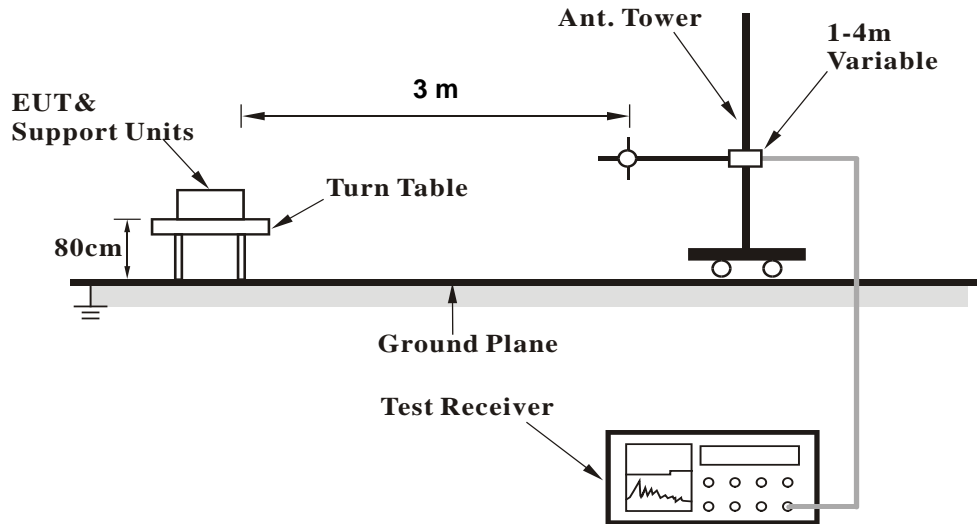

**<Radiated Emission above 1 GHz>**

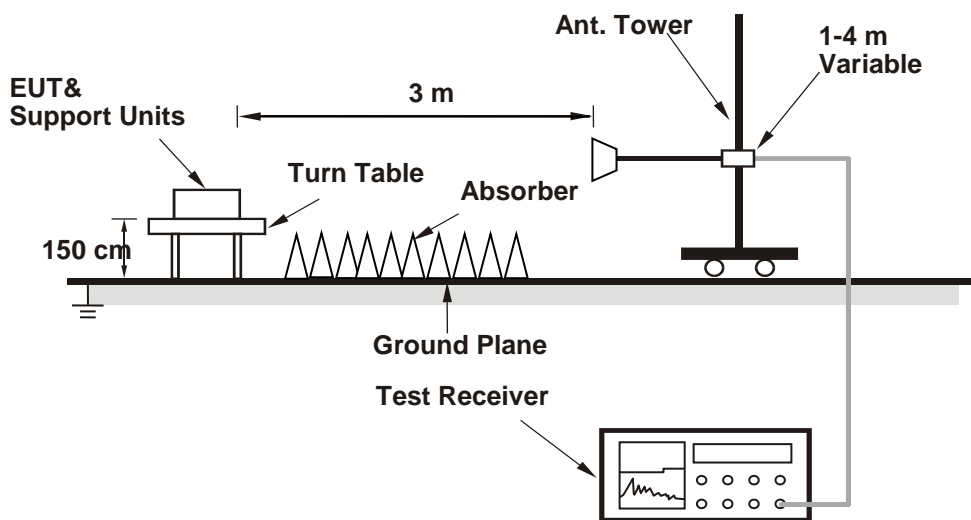

For the actual test configuration, please refer to the attached file (Test Setup Photo).



4.1.4 Test Results

ERP Power (dBm)

LTE Band 12							
Channel Bandwidth: 1.4 MHz / QPSK							
Plane	Channel	Frequency (MHz)	Reading (dBm)	Correction Factor (dB)	ERP (dBm)	ERP (mW)	Polarization (H/V)
Z	23017	699.7	-7.12	32.719	23.45	221.26	H
	23095	707.5	-7.50	32.736	23.09	203.52	
	23173	715.3	-7.01	32.591	23.43	220.34	
	23017	699.7	-9.51	32.69	21.03	126.77	V
	23095	707.5	-9.14	32.81	21.52	141.91	
	23173	715.3	-9.20	32.74	21.39	137.72	
Channel Bandwidth: 1.4 MHz / 16QAM							
Z	23017	699.7	-8.14	32.719	22.43	174.86	H
	23095	707.5	-8.20	32.736	22.39	173.22	
	23173	715.3	-7.89	32.591	22.55	179.93	
	23017	699.7	-9.85	32.69	20.69	117.22	V
	23095	707.5	-9.75	32.81	20.91	123.31	
	23173	715.3	-10.23	32.74	20.36	108.64	

Note: ERP (dBm) = Reading (dBm) + Correction Factor (dB) – 2.15

LTE Band 12							
Channel Bandwidth: 3 MHz / QPSK							
Plane	Channel	Frequency (MHz)	Reading (dBm)	Correction Factor (dB)	ERP (dBm)	ERP (mW)	Polarization (H/V)
Z	23025	700.5	-6.88	32.719	23.69	233.83	H
	23095	707.5	-7.12	32.736	23.46	221.92	
	23165	714.5	-7.08	32.591	23.36	216.82	
	23025	700.5	-9.11	32.69	21.43	138.93	V
	23095	707.5	-9.62	32.81	21.04	127.06	
	23165	714.5	-9.52	32.74	21.07	127.94	
Channel Bandwidth: 3 MHz / 16QAM							
Z	23025	700.5	-8.23	32.719	22.34	171.36	H
	23095	707.5	-8.14	32.736	22.45	175.63	
	23165	714.5	-7.95	32.591	22.49	177.46	
	23025	700.5	-10.52	32.69	20.02	100.46	V
	23095	707.5	-10.36	32.81	20.30	107.15	
	23165	714.5	-10.51	32.74	20.08	101.86	

Note: ERP (dBm) = Reading (dBm) + Correction Factor (dB) – 2.15

LTE Band 12							
Channel Bandwidth: 5 MHz / QPSK							
Plane	Channel	Frequency (MHz)	Reading (dBm)	Correction Factor (dB)	ERP (dBm)	ERP (mW)	Polarization (H/V)
Z	23035	701.5	-7.51	32.719	23.06	202.26	H
	23095	707.5	-7.52	32.736	23.07	202.58	
	23155	713.5	-7.01	32.591	23.43	220.34	
	23035	701.5	-9.32	32.69	21.22	132.43	V
	23095	707.5	-9.66	32.81	21.00	125.89	
	23155	713.5	-9.51	32.74	21.08	128.23	
Channel Bandwidth: 5 MHz / 16QAM							
Z	23035	701.5	-8.52	32.719	22.05	160.29	H
	23095	707.5	-8.01	32.736	22.58	180.97	
	23155	713.5	-8.42	32.591	22.02	159.26	
	23035	701.5	-10.25	32.69	20.29	106.91	V
	23095	707.5	-10.32	32.81	20.34	108.14	
	23155	713.5	-10.16	32.74	20.43	110.41	

Note: ERP (dBm) = Reading (dBm) + Correction Factor (dB) – 2.15

LTE Band 12							
Channel Bandwidth: 10 MHz / QPSK							
Plane	Channel	Frequency (MHz)	Reading (dBm)	Correction Factor (dB)	ERP (dBm)	ERP (mW)	Polarization (H/V)
Z	23060	704.0	-6.62	32.727	23.96	248.71	H
	23095	707.5	-7.15	32.739	23.44	220.75	
	23130	711.0	-7.01	32.728	23.57	227.40	
	23060	704.0	-9.56	32.75	21.04	127.06	V
	23095	707.5	-9.01	32.81	21.65	146.22	
	23130	711.0	-9.53	32.84	21.16	130.62	
Channel Bandwidth: 10 MHz / 16QAM							
Z	23060	704.0	-7.56	32.727	23.02	200.31	H
	23095	707.5	-8.52	32.739	22.07	161.03	
	23130	711.0	-8.01	32.728	22.57	180.63	
	23060	704.0	-10.23	32.75	20.37	108.89	V
	23095	707.5	-10.56	32.81	20.10	102.33	
	23130	711.0	-10.35	32.84	20.34	108.14	

Note: ERP (dBm) = Reading (dBm) + Correction Factor (dB) – 2.15

LTE Band 13							
Channel Bandwidth: 5 MHz / QPSK							
Plane	Channel	Frequency (MHz)	Reading (dBm)	Correction Factor (dB)	ERP (dBm)	ERP (mW)	Polarization (H/V)
X	23205	779.5	-8.12	32.771	22.50	177.87	H
	23230	782.0	-8.53	32.741	22.06	160.73	
	23255	784.5	-8.42	32.854	22.28	169.20	
	23205	779.5	-10.52	32.5	19.83	96.16	V
	23230	782.0	-10.63	32.52	19.74	94.19	
	23255	784.5	-10.75	32.62	19.72	93.76	
Channel Bandwidth: 5 MHz / 16QAM							
X	23205	779.5	-9.56	32.771	21.06	127.67	H
	23230	782.0	-9.01	32.741	21.58	143.91	
	23255	784.5	-8.98	32.854	21.72	148.73	
	23205	779.5	-12.33	32.5	18.02	63.39	V
	23230	782.0	-11.85	32.52	18.52	71.12	
	23255	784.5	-11.76	32.62	18.71	74.25	

Note: ERP (dBm) = Reading (dBm) + Correction Factor (dB) – 2.15

LTE Band 13							
Channel Bandwidth: 10 MHz / QPSK							
Plane	Channel	Frequency (MHz)	Reading (dBm)	Correction Factor (dB)	ERP (dBm)	ERP (mW)	Polarization (H/V)
X	23230	782.0	-8.01	32.737	22.58	181.01	H
	23230	782.0	-10.52	32.52	19.85	96.61	V
Channel Bandwidth: 10 MHz / 16QAM							
X	23230	782.0	-8.75	32.737	21.84	152.65	H
	23230	782.0	-12.10	32.52	18.27	67.14	V

Note: ERP (dBm) = Reading (dBm) + Correction Factor (dB) – 2.15

**EIRP Power (dBm)**

WCDMA							
Plane	Channel	Frequency (MHz)	Reading (dBm)	Correction Factor (dB)	EIRP (dBm)	EIRP (mW)	Polarization (H/V)
X	1312	1712.4	-17.89	42.49	24.59	288.07	H
	1413	1732.6	-18.21	42.33	24.12	258.05	
	1513	1752.6	-17.60	42.10	24.50	281.84	
	1312	1712.4	-23.58	42.99	19.41	87.30	V
	1413	1732.6	-23.13	42.74	19.61	91.41	
	1513	1752.6	-22.87	42.21	19.34	85.90	

Note: EIRP (dBm) = Reading (dBm) + Correction Factor (dB)

LTE Band 4							
Channel Bandwidth: 1.4 MHz / QPSK							
Plane	Channel	Frequency (MHz)	Reading (dBm)	Correction Factor (dB)	EIRP (dBm)	EIRP (mW)	Polarization (H/V)
X	19957	1710.7	-17.99	42.49	24.50	281.51	H
	20175	1732.5	-18.10	42.33	24.23	264.67	
	20393	1754.3	-17.54	42.10	24.56	285.76	
	19957	1710.7	-21.20	42.99	21.79	151.01	V
	20175	1732.5	-20.89	42.74	21.85	153.11	
	20393	1754.3	-20.81	42.21	21.40	138.04	
Channel Bandwidth: 1.4 MHz / 16QAM							
X	19957	1710.7	-18.99	42.49	23.50	223.61	H
	20175	1732.5	-18.57	42.33	23.76	237.52	
	20393	1754.3	-19.10	42.10	23.00	199.53	
	19957	1710.7	-22.11	42.99	20.88	122.41	V
	20175	1732.5	-21.89	42.74	20.85	121.62	
	20393	1754.3	-21.75	42.21	20.46	111.17	

Note: EIRP (dBm) = Reading (dBm) + Correction Factor (dB)

LTE Band 4							
Channel Bandwidth: 3 MHz / QPSK							
Plane	Channel	Frequency (MHz)	Reading (dBm)	Correction Factor (dB)	EIRP (dBm)	EIRP (mW)	Polarization (H/V)
X	19965	1711.5	-17.60	42.49	24.89	307.96	H
	20175	1732.5	-17.60	42.33	24.73	297.10	
	20385	1753.5	-17.81	42.10	24.29	268.53	
	19965	1711.5	-21.21	42.99	21.78	150.66	V
	20175	1732.5	-20.96	42.74	21.78	150.66	
	20385	1753.5	-20.85	42.21	21.36	136.74	
Channel Bandwidth: 3 MHz / 16QAM							
X	19965	1711.5	-18.54	42.49	23.95	248.03	H
	20175	1732.5	-18.44	42.33	23.89	244.74	
	20385	1753.5	-18.65	42.10	23.45	221.31	
	19965	1711.5	-22.42	42.99	20.57	114.02	V
	20175	1732.5	-22.54	42.74	20.20	104.71	
	20385	1753.5	-21.88	42.21	20.33	107.89	

Note: EIRP (dBm) = Reading (dBm) + Correction Factor (dB)

LTE Band 4							
Channel Bandwidth: 5 MHz / QPSK							
Plane	Channel	Frequency (MHz)	Reading (dBm)	Correction Factor (dB)	EIRP (dBm)	EIRP (mW)	Polarization (H/V)
X	19975	1712.5	-17.51	42.49	24.98	314.41	H
	20175	1732.5	-17.61	42.33	24.72	296.28	
	20375	1752.5	-17.43	42.10	24.67	293.09	
	19975	1712.5	-21.23	42.99	21.76	149.97	V
	20175	1732.5	-21.66	42.74	21.08	128.23	
	20375	1752.5	-20.84	42.21	21.37	137.09	
Channel Bandwidth: 5 MHz / 16QAM							
X	19975	1712.5	-18.62	42.49	23.87	243.50	H
	20175	1732.5	-18.41	42.33	23.92	246.43	
	20375	1752.5	-18.75	42.10	23.35	216.27	
	19975	1712.5	-22.65	42.99	20.34	108.14	V
	20175	1732.5	-21.90	42.74	20.84	121.34	
	20375	1752.5	-21.55	42.21	20.66	116.41	

Note: EIRP (dBm) = Reading (dBm) + Correction Factor (dB)

LTE Band 4							
Channel Bandwidth: 10 MHz / QPSK							
Plane	Channel	Frequency (MHz)	Reading (dBm)	Correction Factor (dB)	EIRP (dBm)	EIRP (mW)	Polarization (H/V)
X	20000	1715.0	-17.66	42.49	24.83	303.88	H
	20175	1732.5	-17.95	42.33	24.38	273.97	
	20350	1750.0	-17.84	42.10	24.26	266.69	
	20000	1715.0	-21.36	42.99	21.63	145.55	V
	20175	1732.5	-20.91	42.74	21.83	152.41	
	20350	1750.0	-20.95	42.21	21.26	133.66	
Channel Bandwidth: 10 MHz / 16QAM							
X	20000	1715.0	-18.75	42.49	23.73	236.10	H
	20175	1732.5	-18.65	42.33	23.68	233.18	
	20350	1750.0	-18.27	42.10	23.84	241.82	
	20000	1715.0	-22.54	42.99	20.45	110.92	V
	20175	1732.5	-21.95	42.74	20.79	119.95	
	20350	1750.0	-21.86	42.21	20.35	108.34	

Note: EIRP (dBm) = Reading (dBm) + Correction Factor (dB)

LTE Band 4							
Channel Bandwidth: 15 MHz / QPSK							
Plane	Channel	Frequency (MHz)	Reading (dBm)	Correction Factor (dB)	EIRP (dBm)	EIRP (mW)	Polarization (H/V)
X	20025	1717.5	-17.85	42.49	24.63	290.47	H
	20175	1732.5	-17.81	42.33	24.52	282.94	
	20325	1747.5	-17.94	42.10	24.16	260.50	
	20025	1717.5	-21.59	42.99	21.40	138.04	V
	20175	1732.5	-21.11	42.74	21.63	145.48	
	20325	1747.5	-20.84	42.21	21.37	137.09	
Channel Bandwidth: 15 MHz / 16QAM							
X	20025	1717.5	-18.80	42.49	23.69	233.61	H
	20175	1732.5	-19.32	42.33	23.01	199.85	
	20325	1747.5	-18.77	42.10	23.34	215.53	
	20025	1717.5	-22.50	42.99	20.49	111.94	V
	20175	1732.5	-21.90	42.74	20.85	121.48	
	20325	1747.5	-22.12	42.21	20.09	102.00	

Note: EIRP (dBm) = Reading (dBm) + Correction Factor (dB)

LTE Band 4							
Channel Bandwidth: 20 MHz / QPSK							
Plane	Channel	Frequency (MHz)	Reading (dBm)	Correction Factor (dB)	EIRP (dBm)	EIRP (mW)	Polarization (H/V)
X	20050	1720.0	-17.45	42.49	25.04	318.79	H
	20175	1732.5	-17.54	42.33	24.79	301.09	
	20300	1745.0	-17.85	42.10	24.25	266.32	
	20050	1720.0	-21.23	42.99	21.76	149.97	V
	20175	1732.5	-20.95	42.74	21.79	151.01	
	20300	1745.0	-20.88	42.21	21.33	135.85	
Channel Bandwidth: 20 MHz / 16QAM							
X	20050	1720.0	-18.35	42.49	24.14	259.12	H
	20175	1732.5	-18.66	42.33	23.67	232.65	
	20300	1745.0	-18.71	42.10	23.39	218.27	
	20050	1720.0	-22.62	42.99	20.37	108.89	V
	20175	1732.5	-21.99	42.74	20.75	118.85	
	20300	1745.0	-22.21	42.21	20.00	100.00	

Note: EIRP (dBm) = Reading (dBm) + Correction Factor (dB)



## 4.2 Radiated Emission Measurement

### 4.2.1 Limits of Radiated Emission Measurement

- a. The power of any emission outside a licensee's frequency block shall be attenuated below the transmitter power (P) by at least  $43 + 10 \log (P)$  dB. The limit of emission is equal to -13 dBm.
- b. For operations in the 775-788 MHz, emissions in the band 1559-1610 MHz shall be limited to -70 dBW/MHz. The limit of emissions is equal to -40 dBm.

### 4.2.2 Test Procedure

- a. Substitution method is used for E.I.R.P measurement. In the semi-anechoic chamber, EUT placed on the 0.8 m (below or equal 1 GHz) and/or 1.5 m (above 1 GHz) height of Turn Table, rotated the table around 360 degrees to search the maximum radiation power and receiver antenna shall be rotated vertical and horizontal polarization and moved height from 1 m to 4 m to find the maximum polar radiated power. The "Read Value" is the spectrum reading the maximum power value.
- b. The substitution horn antenna is substituted for EUT at the same position and signals generator export the CW signal to the substitution antenna via a TX cable. Rotated the Turn Table and moved receiving antenna to find the maximum radiation power. Adjust output power level of S.G to get a Value of spectrum reading equal to "Read Value" of step a. Record the power level of S.G.
- c.  $EIRP = \text{Output power level of S.G} - \text{TX cable loss} + \text{Antenna gain of substitution horn}$ .
- d. E.R.P power can be calculated form E.I.R.P power by subtracting the gain of dipole,  $E.R.P \text{ power} = E.I.R.P \text{ power} - 2.15 \text{ dB}$ .

**Note:** The resolution bandwidth of spectrum analyzer is 1 MHz and the video bandwidth is 3 MHz.

### 4.2.3 Deviation from Test Standard

No deviation.

4.2.4 Test Setup

<Radiated Emission below or equal 1 GHz>

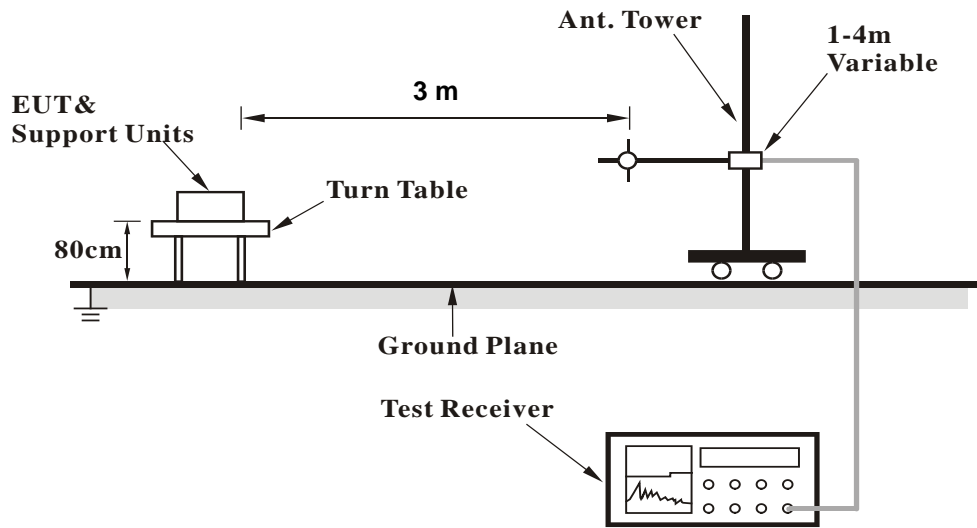

<Radiated Emission above 1 GHz>

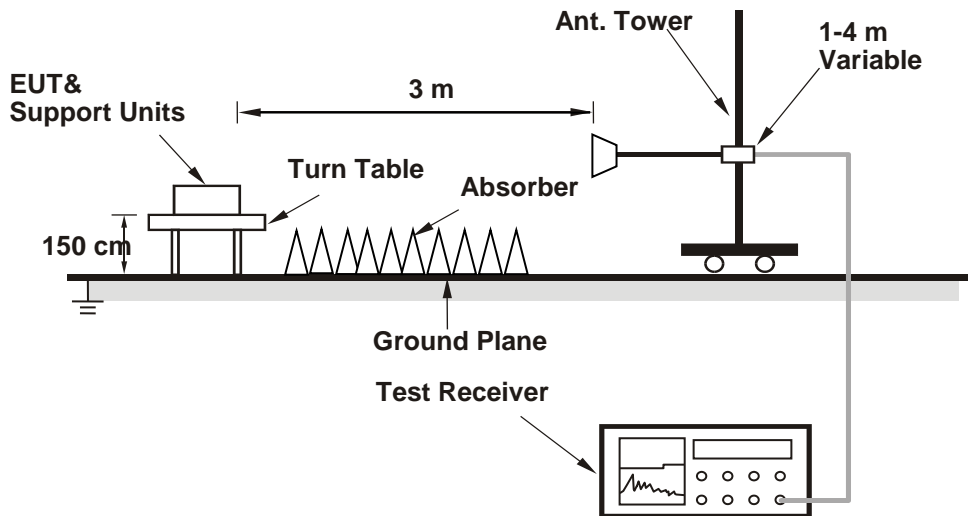

For the actual test configuration, please refer to the attached file (Test Setup Photo).

4.2.5 Test Results

WCDMA:  
Low Channel



Bureau Veritas Consumer Products Services Ltd., Taoyuan Branch

A D T

Data: 9

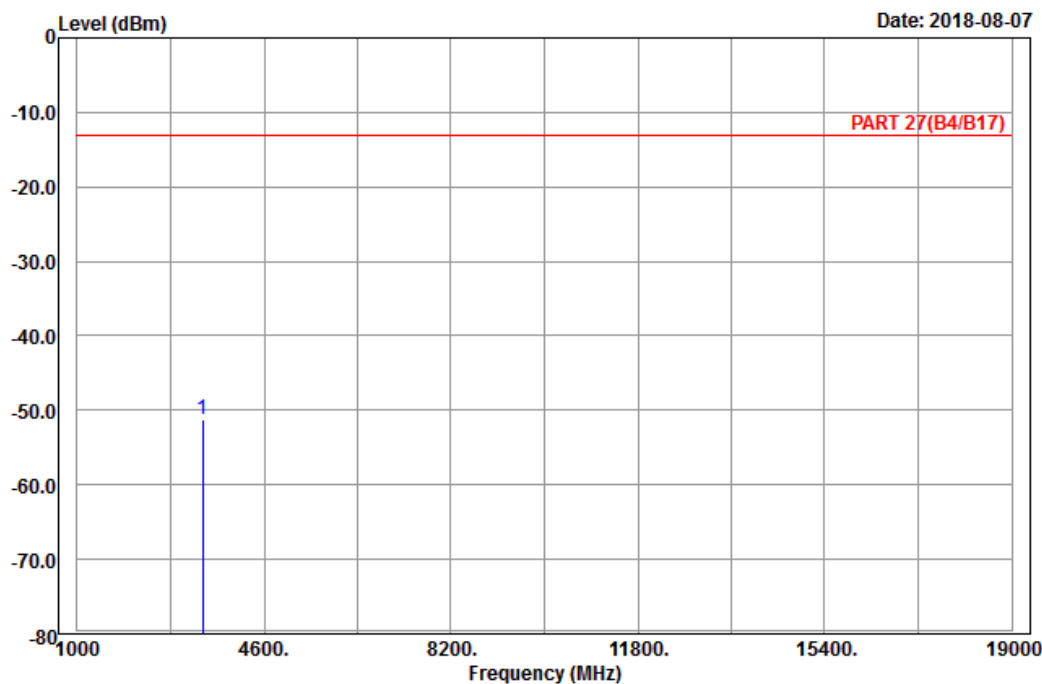

Site : 966 chamber 1  
Condition: PART 27(B4/B17) Horizontal  
Remark : Band IV\_Link\_CH1312  
Tested by: Karl Lee

	Freq	Level	Read Level	Limit Line	Over Limit	Factor	Remark
	MHz	dBm	dBm	dBm	dB	dB	
1	pp 3424.80	-51.14	-65.51	-13.00	-38.14	14.37	Peak



Bureau Veritas Consumer Products Services Ltd., Taoyuan Branch

A D T

Data: 10

Date: 2018-08-07

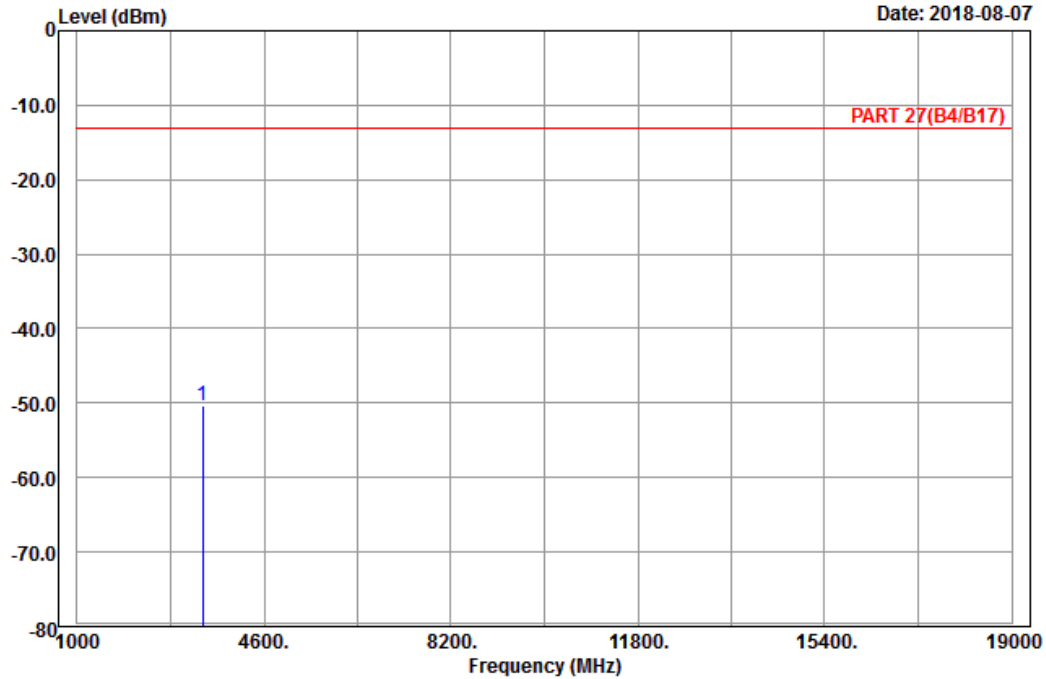

Site : 966 chamber 1  
 Condition: PART 27(B4/B17) Vertical  
 Remark : Band IV\_Link\_CH1312  
 Tested by: Karl Lee

	Freq	Level	Read Level	Limit Line	Over Limit	Factor	Remark
	MHz	dBm	dBm	dBm	dB	dB	
1	pp 3424.80	-50.25	-64.62	-13.00	-37.25	14.37	Peak

Middle Channel



Bureau Veritas Consumer Products Services Ltd., Taoyuan Branch

A D T

Data: 9

Date: 2018-08-07

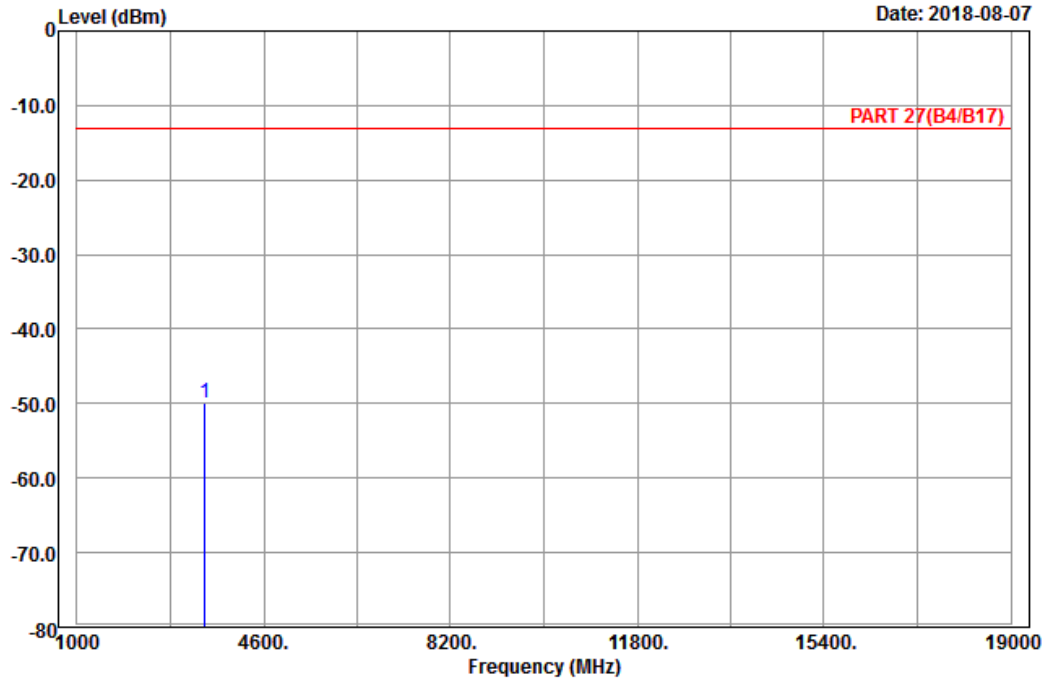

Site : 966 chamber 1  
 Condition: PART 27(B4/B17) Horizontal  
 Remark : Band IV\_Link\_CH1413  
 Tested by: Karl Lee

	Freq	Level	Read Level	Limit Line	Over Limit	Factor	Remark
	MHz	dBm	dBm	dBm	dB	dB	
1	pp 3465.20	-49.98	-64.32	-13.00	-36.98	14.34	Peak



Bureau Veritas Consumer Products Services Ltd., Taoyuan Branch

A D T

Data: 10

Date: 2018-08-07

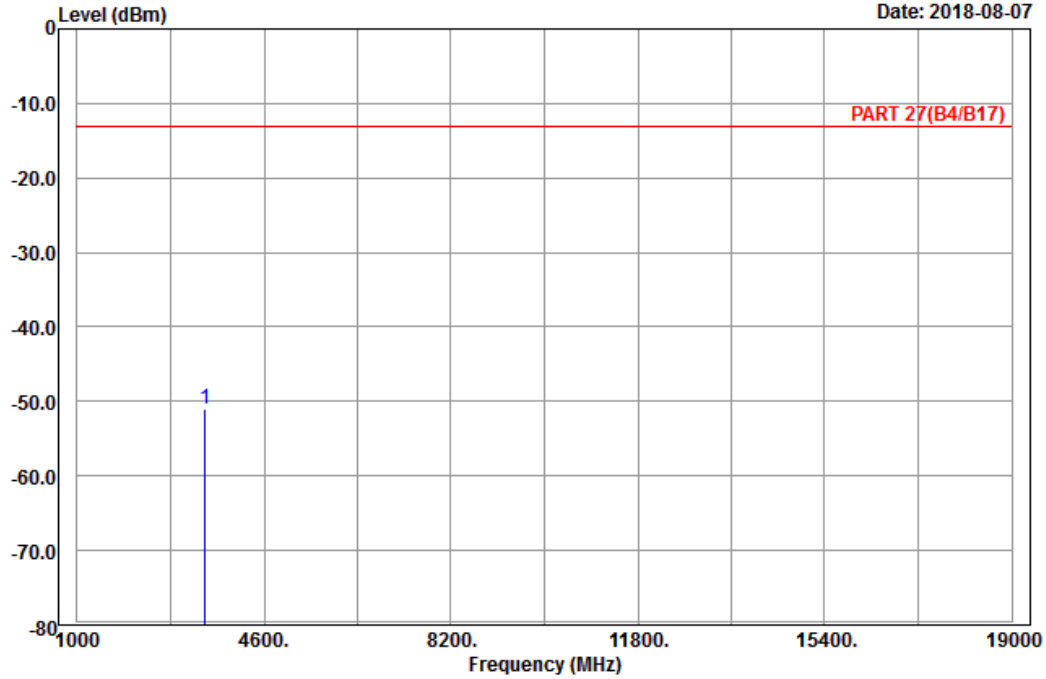

Site : 966 chamber 1  
 Condition: PART 27(B4/B17) Vertical  
 Remark : Band IV\_Link\_CH1413  
 Tested by: Karl Lee

	Freq	Level	Read Level	Limit Line	Over Limit	Factor	Remark
	MHz	dBm	dBm	dBm	dB	dB	
1 pp	3465.20	-50.95	-65.29	-13.00	-37.95	14.34	Peak

# High Channel



Bureau Veritas Consumer Products Services Ltd., Taoyuan Branch

A D T

Data: 13

Date: 2018-08-07

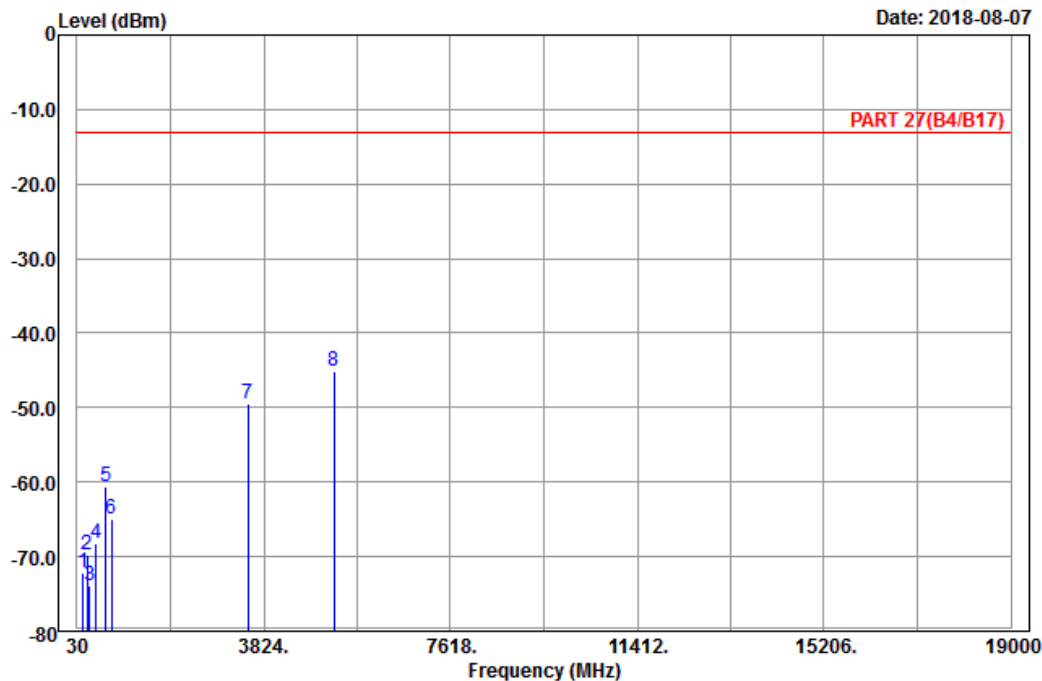

Site : 966 chamber 1  
 Condition: PART 27(B4/B17) Horizontal  
 Remark : Band IV\_Link\_CH1513  
 Tested by: Karl Lee

	Freq	Level	Read Level	Limit Line	Over Limit	Factor	Remark
	MHz	dBm	dBm	dBm	dB	dB	
1	159.60	-72.09	-64.42	-13.00	-59.09	-7.67	Peak
2	234.39	-69.71	-63.99	-13.00	-56.71	-5.72	Peak
3	283.26	-73.98	-68.17	-13.00	-60.98	-5.81	Peak
4	424.60	-68.25	-64.96	-13.00	-55.25	-3.29	Peak
5	610.10	-60.68	-61.00	-13.00	-47.68	0.32	Peak
6	731.90	-64.92	-63.94	-13.00	-51.92	-0.98	Peak
7	3505.20	-49.40	-63.68	-13.00	-36.40	14.28	Peak
8 pp	5257.80	-45.13	-65.33	-13.00	-32.13	20.20	Peak



Bureau Veritas Consumer Products Services Ltd., Taoyuan Branch

A D T

Data: 14

Date: 2018-08-07

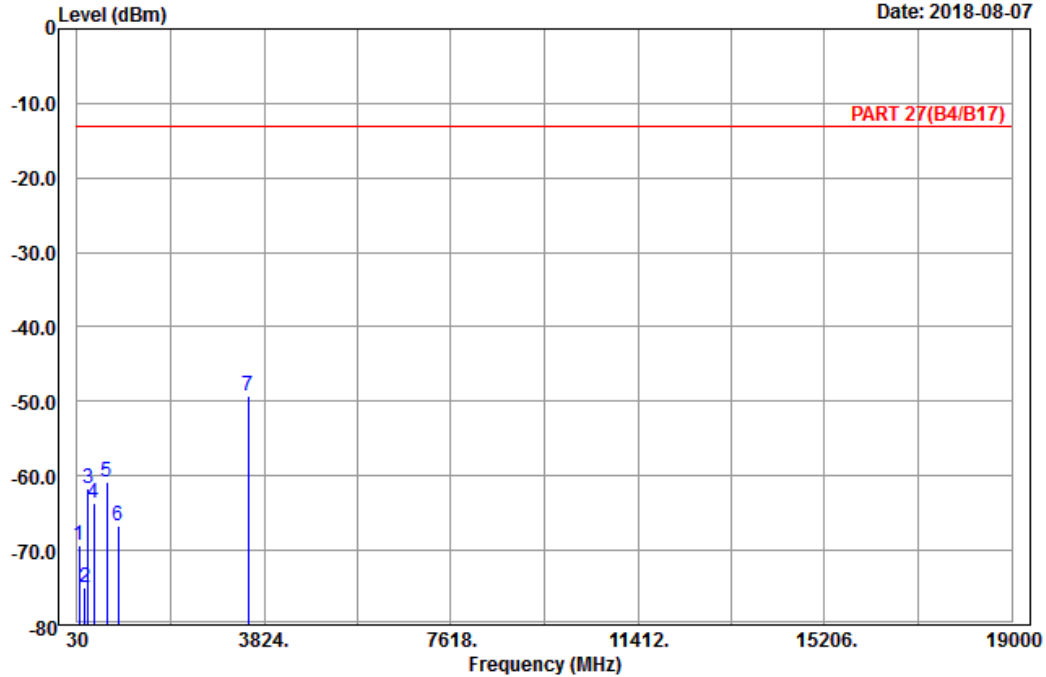

Site : 966 chamber 1  
 Condition: PART 27(B4/B17) Vertical  
 Remark : Band IV\_Link\_CH1513  
 Tested by: Karl Lee

	Freq	Level	Read Level	Limit Line	Over Limit	Factor	Remark
	MHz	dBm	dBm	dBm	dB	dB	
1	79.14	-69.30	-57.45	-13.00	-56.30	-11.85	Peak
2	189.30	-75.00	-69.28	-13.00	-62.00	-5.72	Peak
3	254.91	-61.73	-56.18	-13.00	-48.73	-5.55	Peak
4	366.50	-63.63	-59.13	-13.00	-50.63	-4.50	Peak
5	632.50	-60.74	-60.80	-13.00	-47.74	0.06	Peak
6	870.50	-66.77	-68.80	-13.00	-53.77	2.03	Peak
7 pp	3505.20	-49.22	-63.50	-13.00	-36.22	14.28	Peak



LTE Band 4  
 Channel Bandwidth: 1.4 MHz / QPSK  
 Low Channel



Bureau Veritas Consumer Products Services Ltd., Taoyuan Branch

A D T

Data: 9

Date: 2018-08-04

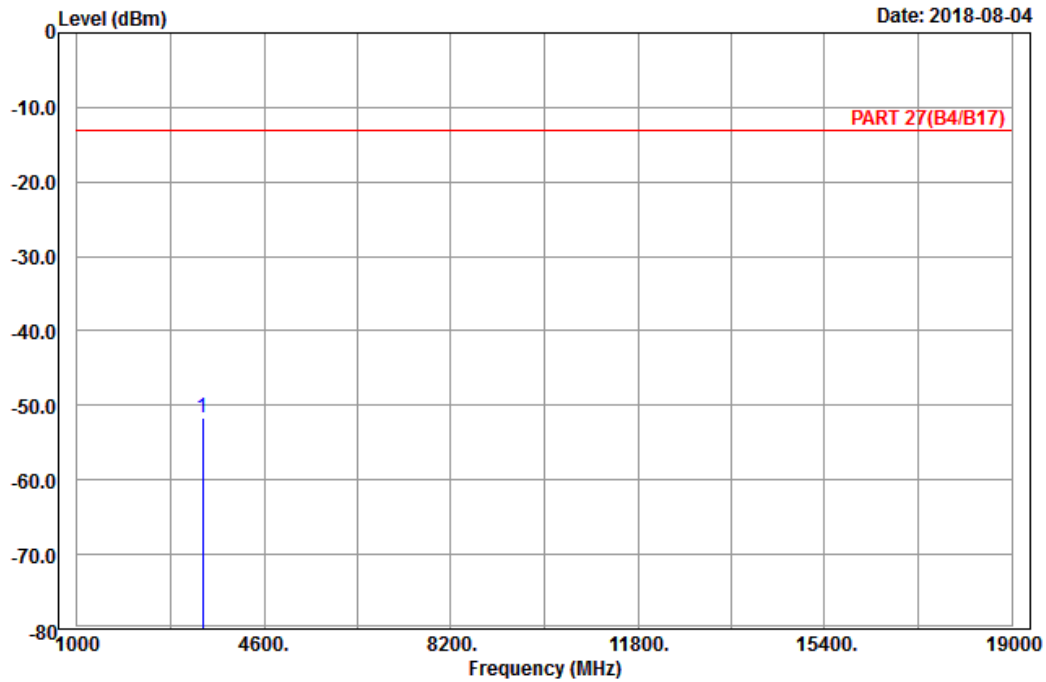

Site : 966 chamber 1  
 Condition: PART 27(B4/B17) Horizontal  
 Remark : LTE\_Band 4\_Link\_CH19957  
 Tested by: Karl Lee

	Read	Limit	Over			
Freq	Level	Level	Line	Limit	Factor	Remark
MHz	dBm	dBm	dBm	dB	dB	
1 pp 3421.40	-51.69	-66.06	-13.00	-38.69	14.37	Peak



Bureau Veritas Consumer Products Services Ltd., Taoyuan Branch

A D T

Data: 10

Date: 2018-08-04

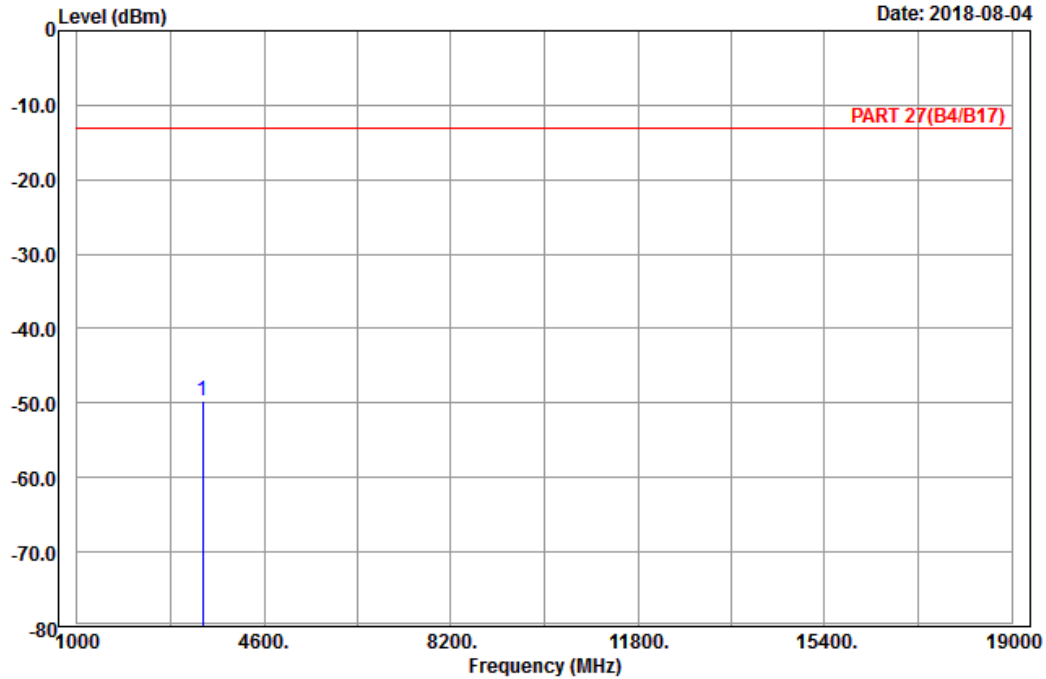

Site : 966 chamber 1  
 Condition: PART 27(B4/B17) Vertical  
 Remark : LTE\_Band 4\_Link\_CH19957  
 Tested by: Karl Lee

	Freq	Level	Read Level	Limit Line	Over Limit	Factor	Remark
	MHz	dBm	dBm	dBm	dB	dB	
1 pp	3421.40	-49.62	-63.99	-13.00	-36.62	14.37	Peak

Middle Channel



Bureau Veritas Consumer Products Services Ltd., Taoyuan Branch

A D T

Data: 9

Date: 2018-08-04

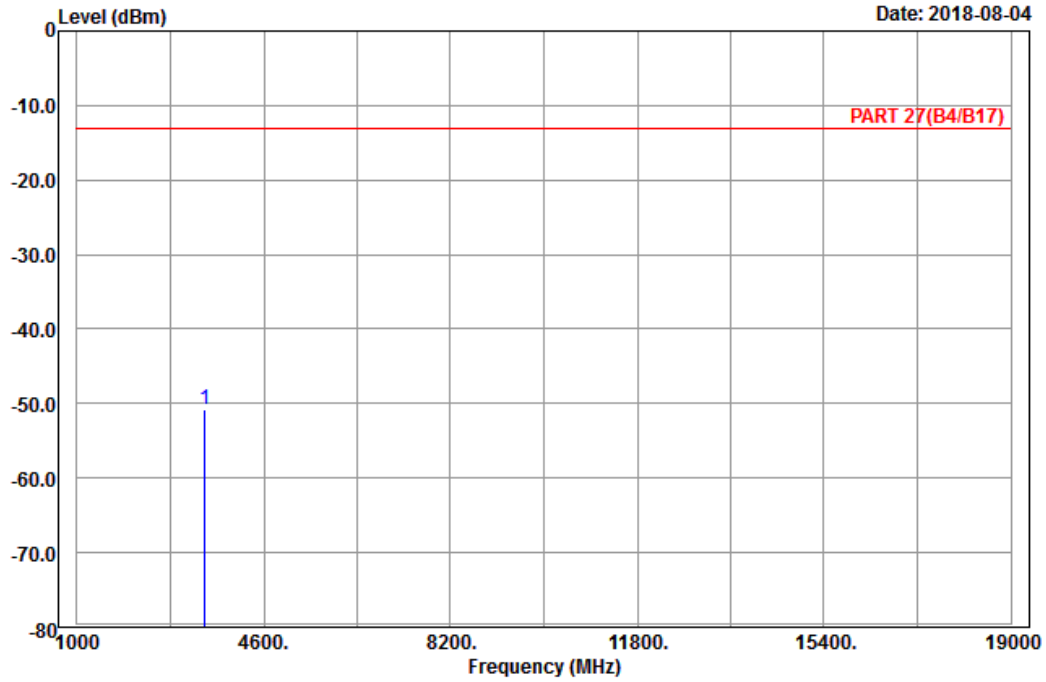

Site : 966 chamber 1  
 Condition: PART 27(B4/B17) Horizontal  
 Remark : LTE\_Band 4\_Link\_CH20175  
 Tested by: Karl Lee

	Freq	Level	Read Level	Limit Line	Over Limit	Factor	Remark
	MHz	dBm	dBm	dBm	dB	dB	
1	pp 3465.00	-50.68	-65.02	-13.00	-37.68	14.34	Peak



Bureau Veritas Consumer Products Services Ltd., Taoyuan Branch

A D T

Data: 10

Date: 2018-08-04

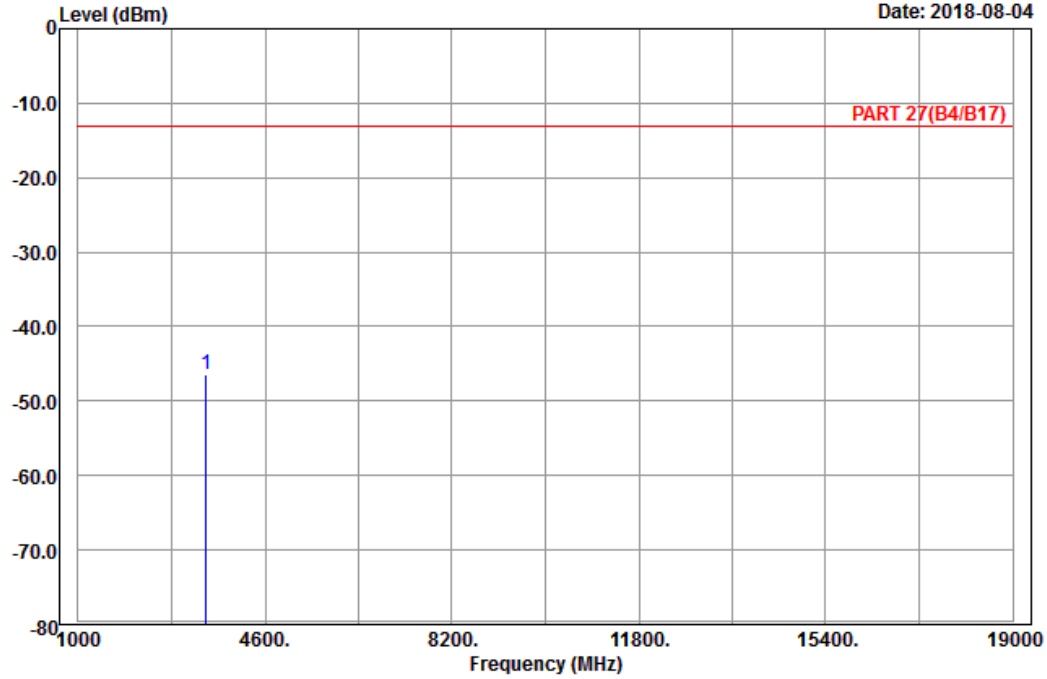

Site : 966 chamber 1  
 Condition: PART 27(B4/B17) Vertical  
 Remark : LTE\_Band 4\_Link\_CH20175  
 Tested by: Karl Lee

	Freq	Level	Read Level	Limit Line	Over Limit	Factor	Remark
	MHz	dBm	dBm	dBm	dB	dB	
1	pp 3465.00	-46.36	-60.70	-13.00	-33.36	14.34	Peak

High Channel



Bureau Veritas Consumer Products Services Ltd., Taoyuan Branch

A D T

Data: 9

Date: 2018-08-04

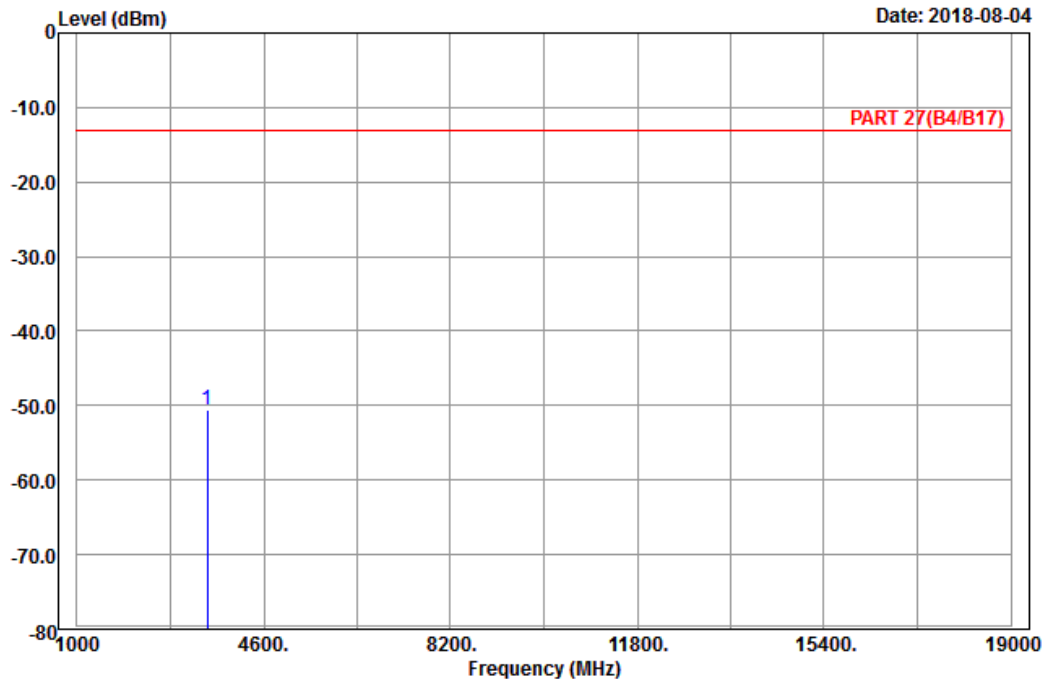

Site : 966 chamber 1  
 Condition: PART 27(B4/B17) Horizontal  
 Remark : LTE\_Band 4\_Link\_CH20393  
 Tested by: Karl Lee

	Read	Limit	Over			
Freq	Level	Level	Line	Limit	Factor	Remark
MHz	dBm	dBm	dBm	dB	dB	
1 pp 3508.60	-50.52	-64.80	-13.00	-37.52	14.28	Peak



Bureau Veritas Consumer Products Services Ltd., Taoyuan Branch

A D T

Data: 10

Date: 2018-08-04

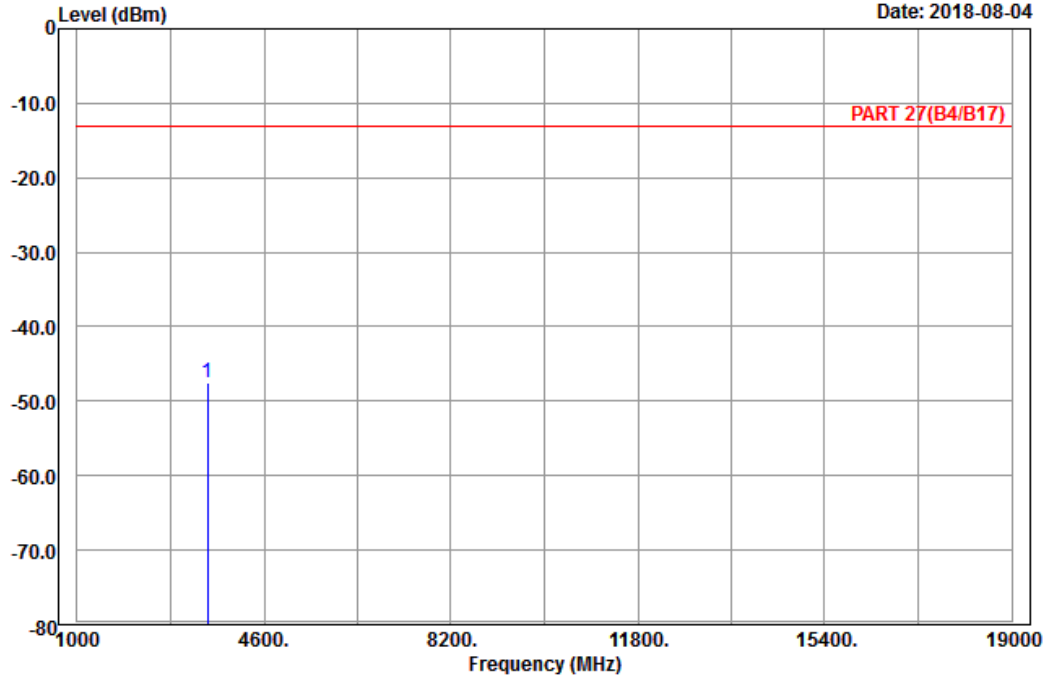

Site : 966 chamber 1  
 Condition: PART 27(B4/B17) Vertical  
 Remark : LTE\_Band 4\_Link\_CH20393  
 Tested by: Karl Lee

	Freq	Level	Read Level	Limit Line	Over Limit	Factor	Remark
	MHz	dBm	dBm	dBm	dB	dB	
1	pp 3508.60	-47.62	-61.90	-13.00	-34.62	14.28	Peak

Channel Bandwidth: 5 MHz / QPSK  
Low Channel



Bureau Veritas Consumer Products Services Ltd., Taoyuan Branch

A D T

Data: 9

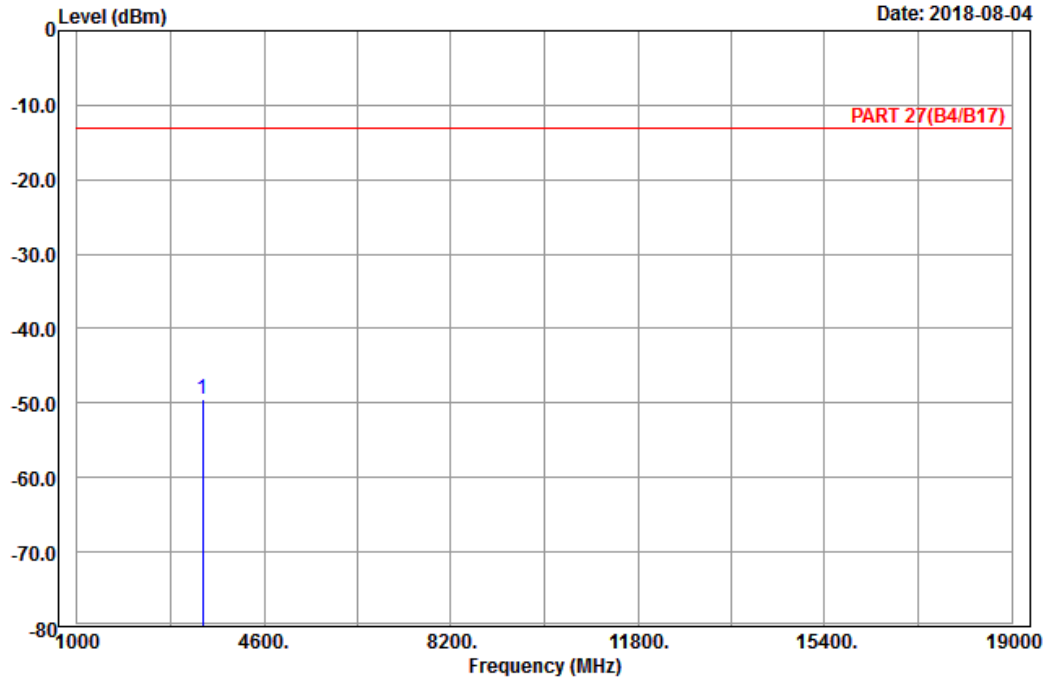

Site : 966 chamber 1  
Condition: PART 27(B4/B17) Horizontal  
Remark : LTE\_Band 4\_Link\_CH19975  
Tested by: Karl Lee

	Freq	Level	Read Level	Limit Line	Over Limit	Factor	Remark
	MHz	dBm	dBm	dBm	dB	dB	
1	pp 3425.00	-49.59	-63.96	-13.00	-36.59	14.37	Peak



Bureau Veritas Consumer Products Services Ltd., Taoyuan Branch

A D T

Data: 10

Date: 2018-08-04

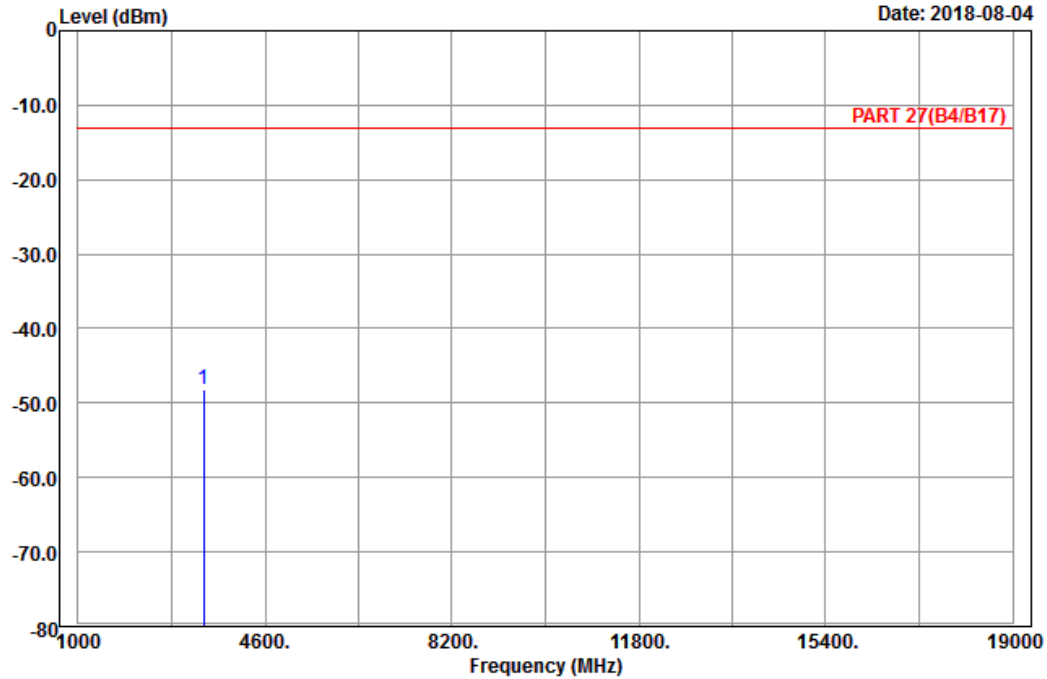

Site : 966 chamber 1  
 Condition: PART 27(B4/B17) Vertical  
 Remark : LTE\_Band 4\_Link\_CH19975  
 Tested by: Karl Lee

	Freq	Level	Read Level	Limit Line	Over Limit	Factor	Remark
	MHz	dBm	dBm	dBm	dB	dB	
1 pp	3425.00	-48.23	-62.60	-13.00	-35.23	14.37	Peak



Middle Channel



Bureau Veritas Consumer Products Services Ltd., Taoyuan Branch

A D T

Data: 9

Date: 2018-08-03

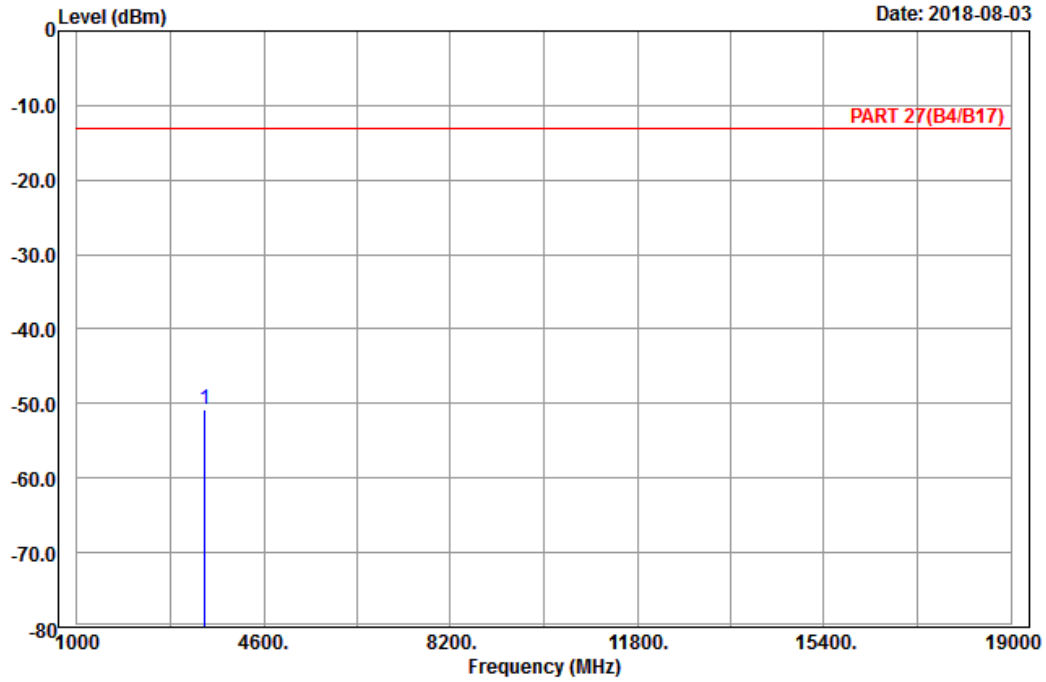

Site : 966 chamber 1  
 Condition: PART 27(B4/B17) Horizontal  
 Remark : LTE\_Band 4\_Link\_CH20175  
 Tested by: Karl Lee

	Read	Limit	Over			
Freq	Level	Level	Line	Limit	Factor	Remark
MHz	dBm	dBm	dBm	dB	dB	
1 pp 3465.00	-50.69	-65.03	-13.00	-37.69	14.34	Peak



Bureau Veritas Consumer Products Services Ltd., Taoyuan Branch

A D T

Data: 10

Date: 2018-08-03

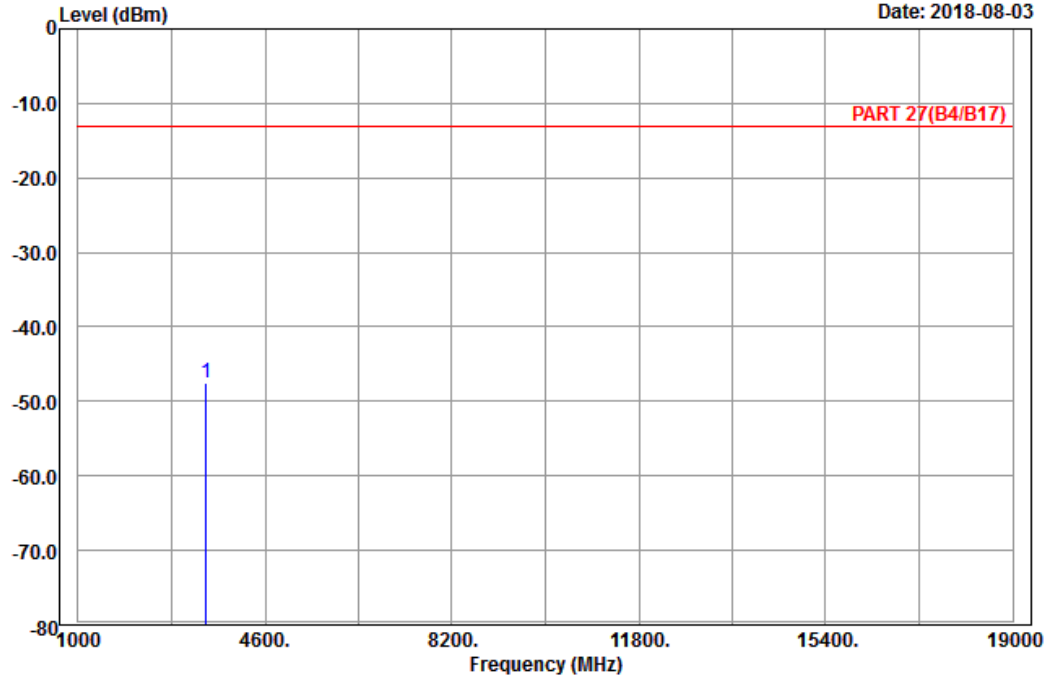

Site : 966 chamber 1  
 Condition: PART 27(B4/B17) Vertical  
 Remark : LTE\_Band 4\_Link\_CH20175  
 Tested by: Karl Lee

	Freq	Level	Read Level	Limit Line	Over Limit	Factor	Remark
	MHz	dBm	dBm	dBm	dB	dB	
1	pp 3465.00	-47.44	-61.78	-13.00	-34.44	14.34	Peak

High Channel



Bureau Veritas Consumer Products Services Ltd., Taoyuan Branch

A D T

Data: 9

Date: 2018-08-04

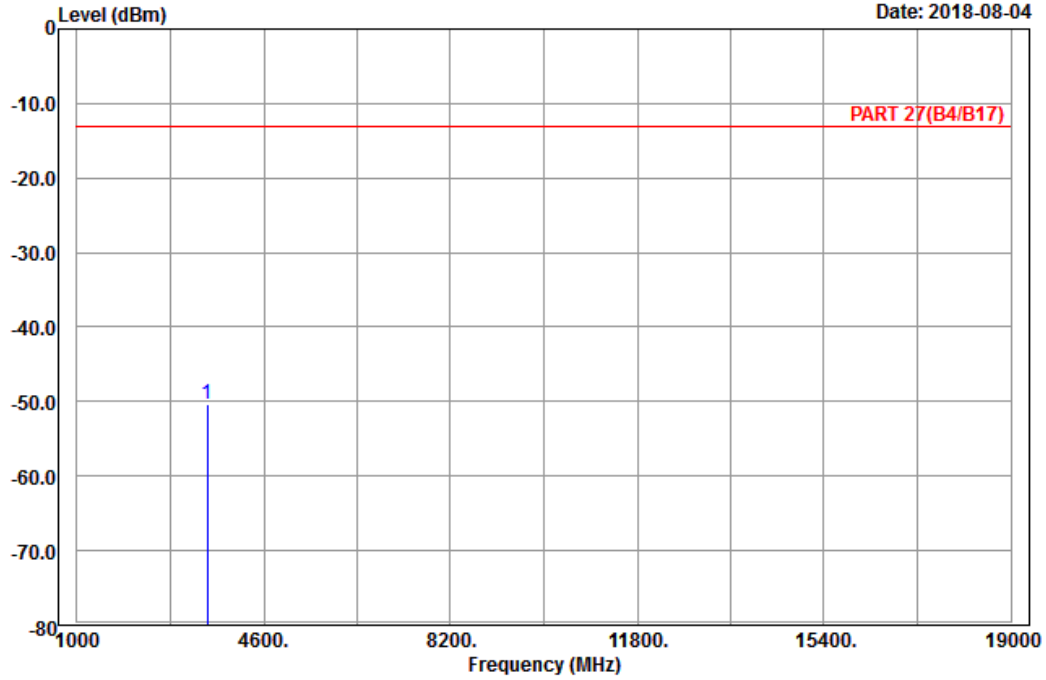

Site : 966 chamber 1  
 Condition: PART 27(B4/B17) Horizontal  
 Remark : LTE\_Band 4\_Link\_CH20375  
 Tested by: Karl Lee

	Freq	Level	Read Level	Limit Line	Over Limit	Factor	Remark
	MHz	dBm	dBm	dBm	dB	dB	
1	pp 3505.00	-50.42	-64.70	-13.00	-37.42	14.28	Peak



Bureau Veritas Consumer Products Services Ltd., Taoyuan Branch

A D T

Data: 10

Date: 2018-08-04

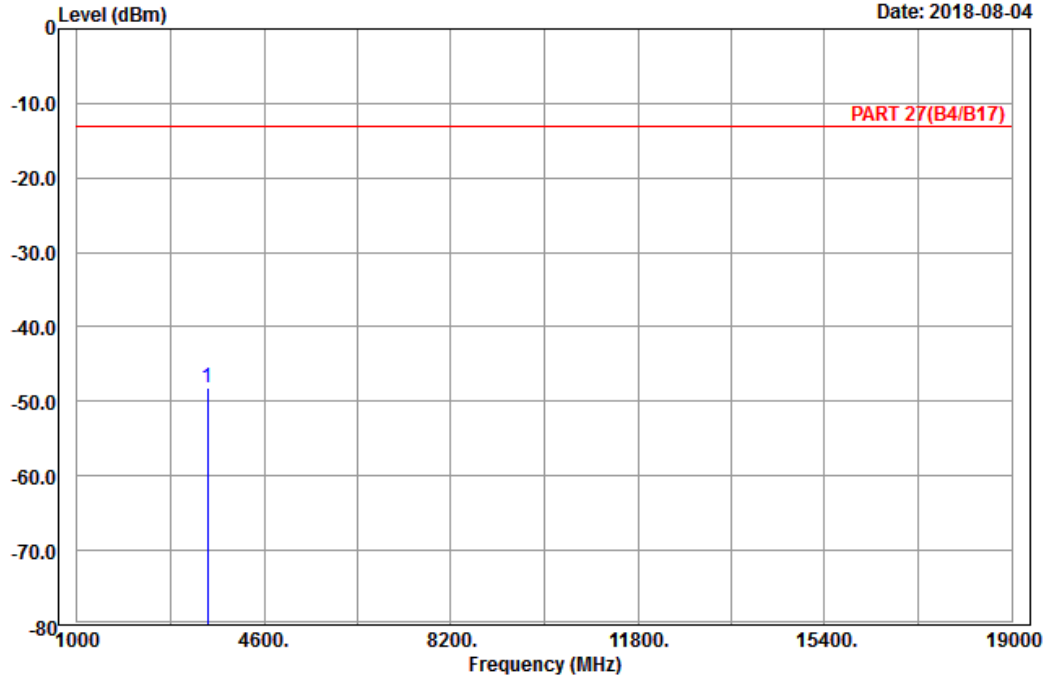

Site : 966 chamber 1  
 Condition: PART 27(B4/B17) Vertical  
 Remark : LTE\_Band 4\_Link\_CH20375  
 Tested by: Karl Lee

	Freq	Level	Read Level	Limit Line	Over Limit	Factor	Remark
	MHz	dBm	dBm	dBm	dB	dB	
1	pp 3505.00	-48.24	-62.52	-13.00	-35.24	14.28	Peak

Channel Bandwidth: 20 MHz / QPSK  
Low Channel



Bureau Veritas Consumer Products Services Ltd., Taoyuan Branch

A D T

Data: 13

Date: 2018-08-03

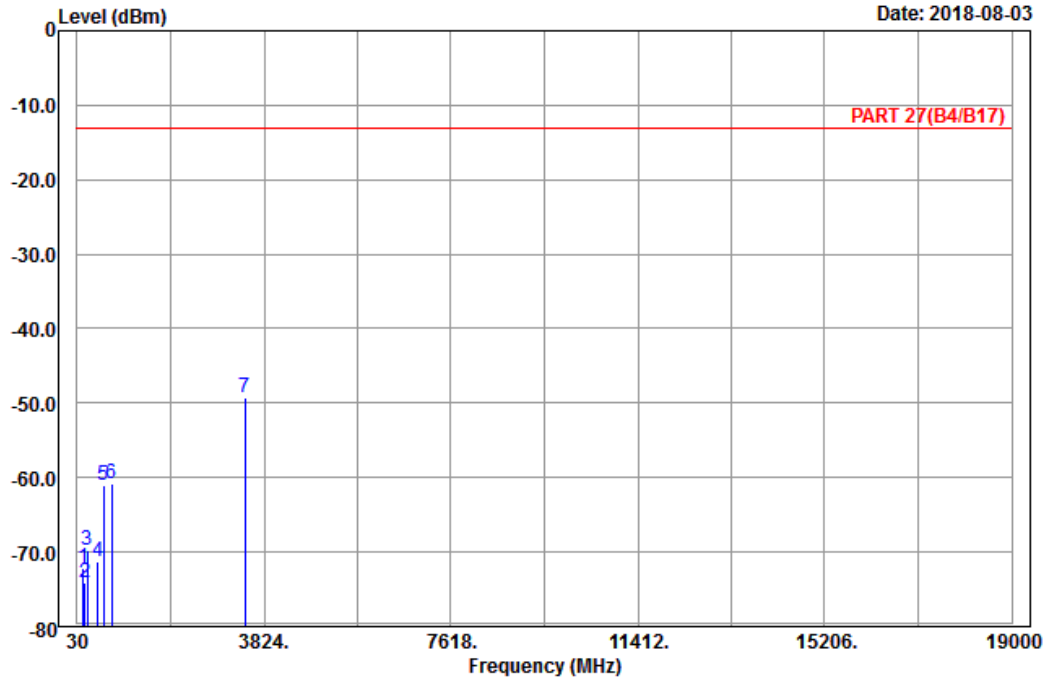

Site : 966 chamber 1  
Condition: PART 27(B4/B17) Horizontal  
Remark : LTE\_Band 4\_Link\_CH20050  
Tested by: Karl Lee

	Freq	Level	Read Level	Limit Line	Over Limit	Factor	Remark
	MHz	dBm	dBm	dBm	dB	dB	
1	160.14	-72.17	-64.50	-13.00	-59.17	-7.67	Peak
2	188.22	-74.10	-68.40	-13.00	-61.10	-5.70	Peak
3	237.36	-69.83	-64.15	-13.00	-56.83	-5.68	Peak
4	455.40	-71.35	-67.34	-13.00	-58.35	-4.01	Peak
5	559.00	-61.09	-59.79	-13.00	-48.09	-1.30	Peak
6	728.40	-60.85	-59.94	-13.00	-47.85	-0.91	Peak
7 pp	3440.00	-49.22	-63.57	-13.00	-36.22	14.35	Peak



Bureau Veritas Consumer Products Services Ltd., Taoyuan Branch

A D T

Data: 14

Date: 2018-08-03

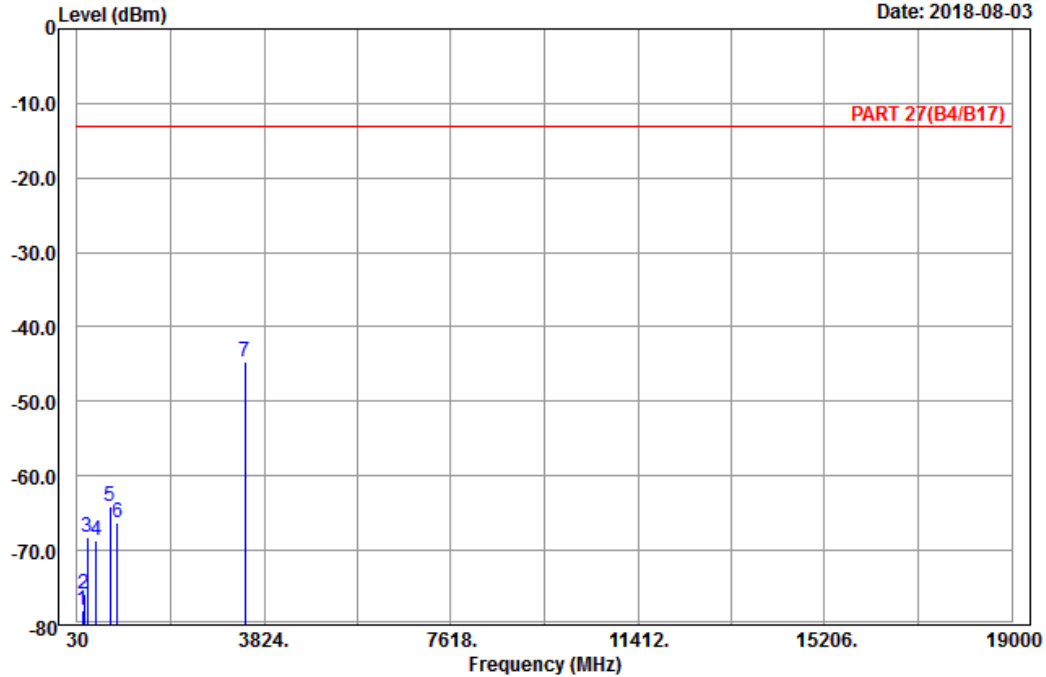

Site : 966 chamber 1  
 Condition: PART 27(B4/B17) Vertical  
 Remark : LTE\_Band 4\_Link\_CH20050  
 Tested by: Karl Lee

	Freq	Level	Read Level	Limit Line	Over Limit	Factor	Remark
	MHz	dBm	dBm	dBm	dB	dB	
1	138.00	-77.97	-70.29	-13.00	-64.97	-7.68	Peak
2	174.18	-75.83	-69.64	-13.00	-62.83	-6.19	Peak
3	244.11	-68.18	-62.59	-13.00	-55.18	-5.59	Peak
4	409.90	-68.66	-65.69	-13.00	-55.66	-2.97	Peak
5	694.10	-64.10	-63.75	-13.00	-51.10	-0.35	Peak
6	842.50	-66.26	-67.79	-13.00	-53.26	1.53	Peak
7 pp	3440.00	-44.69	-59.04	-13.00	-31.69	14.35	Peak

Middle Channel



Bureau Veritas Consumer Products Services Ltd., Taoyuan Branch

A D T

Data: 9

Date: 2018-08-03

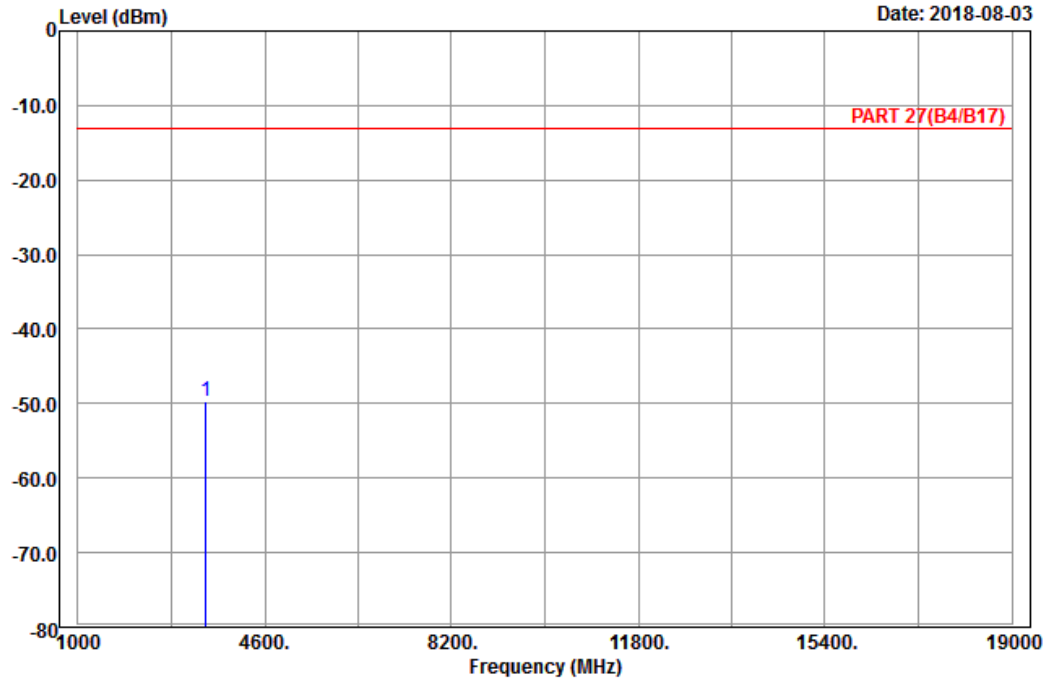

Site : 966 chamber 1  
 Condition: PART 27(B4/B17) Horizontal  
 Remark : LTE\_Band 4\_Link\_CH20175  
 Tested by: Karl Lee

	Read	Limit	Over			
Freq	Level	Level	Line	Limit	Factor	Remark
MHz	dBm	dBm	dBm	dB	dB	
1 pp 3465.00	-49.81	-64.15	-13.00	-36.81	14.34	Peak



Bureau Veritas Consumer Products Services Ltd., Taoyuan Branch

A D T

Data: 10

Date: 2018-08-03

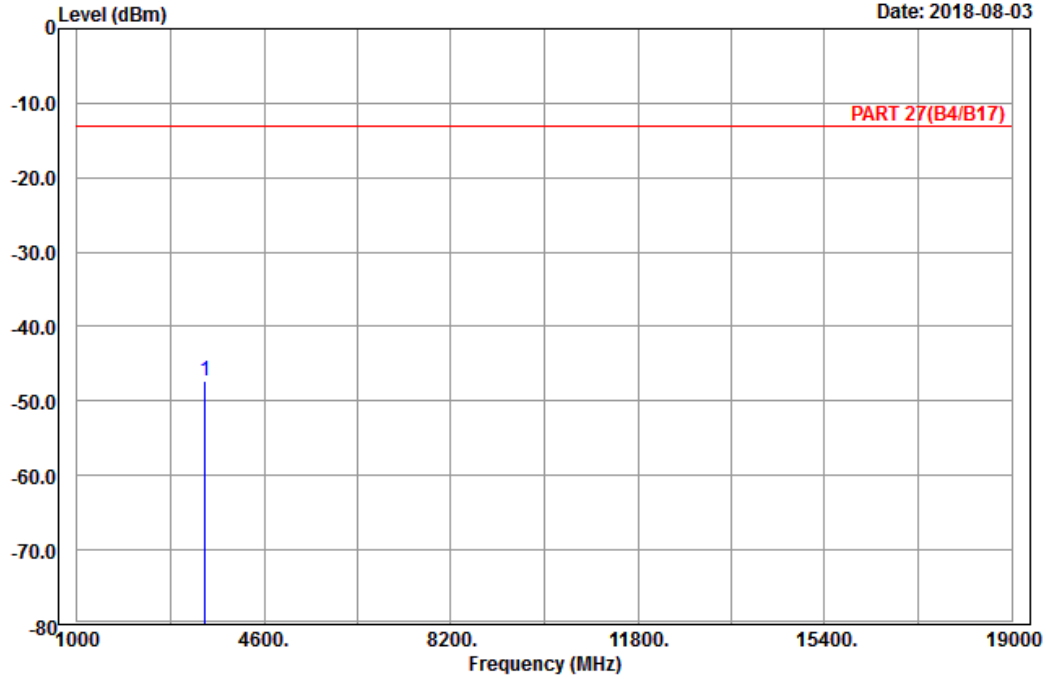

Site : 966 chamber 1  
 Condition: PART 27(B4/B17) Vertical  
 Remark : LTE\_Band 4\_Link\_CH20175  
 Tested by: Karl Lee

	Freq	Level	Read Level	Limit Line	Over Limit	Factor	Remark
	MHz	dBm	dBm	dBm	dB	dB	
1	pp 3465.00	-47.38	-61.72	-13.00	-34.38	14.34	Peak



High Channel



Bureau Veritas Consumer Products Services Ltd., Taoyuan Branch

A D T

Data: 9

Date: 2018-08-03

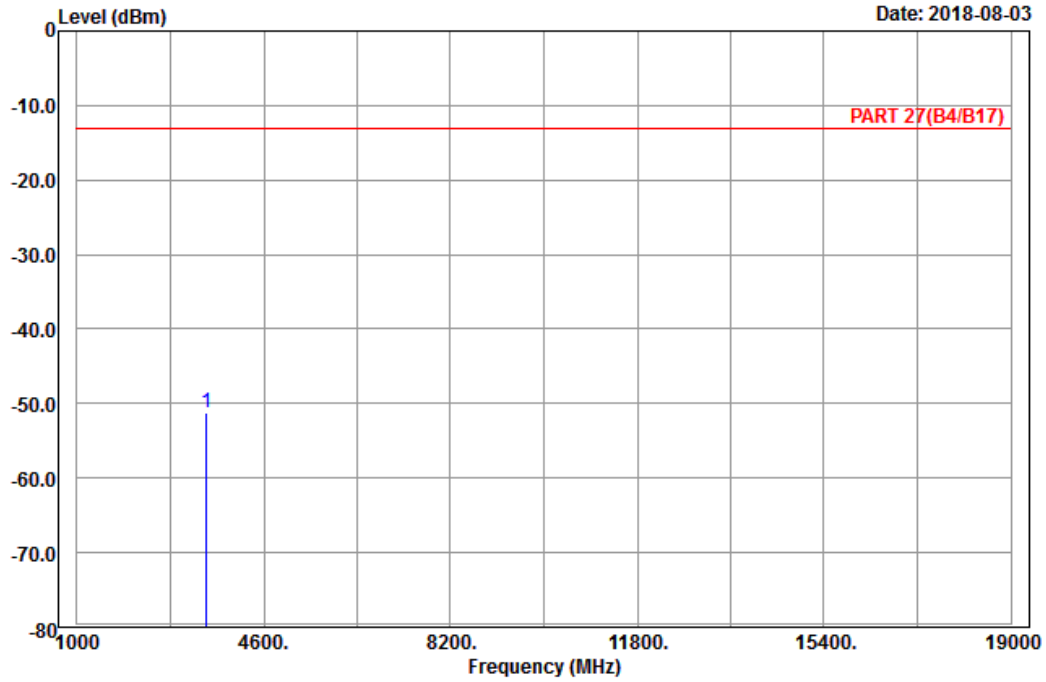

Site : 966 chamber 1  
 Condition: PART 27(B4/B17) Horizontal  
 Remark : LTE\_Band 4\_Link\_CH20300  
 Tested by: Karl Lee

	Freq	Level	Read Level	Limit Line	Over Limit	Factor	Remark
	MHz	dBm	dBm	dBm	dB	dB	
1	pp 3490.00	-51.21	-65.52	-13.00	-38.21	14.31	Peak



Bureau Veritas Consumer Products Services Ltd., Taoyuan Branch

A D T

Data: 10

Date: 2018-08-03

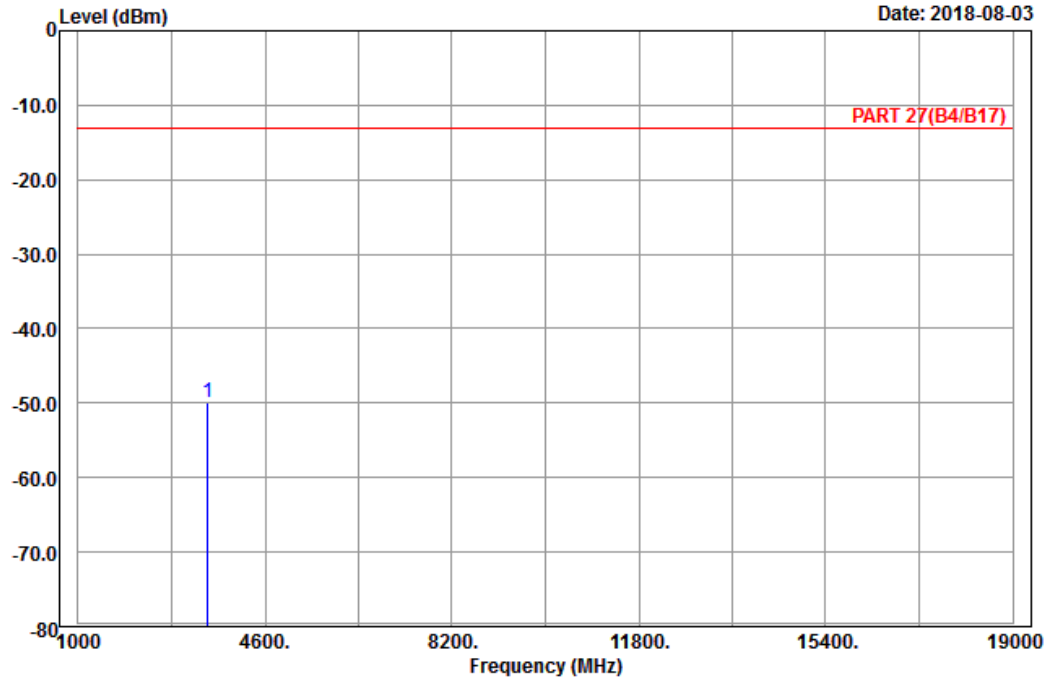

Site : 966 chamber 1  
 Condition: PART 27(B4/B17) Vertical  
 Remark : LTE\_Band 4\_Link\_CH20300  
 Tested by: Karl Lee

	Freq	Level	Read Level	Limit Line	Over Limit	Factor	Remark
	MHz	dBm	dBm	dBm	dB	dB	
1	pp 3490.00	-49.99	-64.30	-13.00	-36.99	14.31	Peak

LTE Band 12  
Channel Bandwidth: 1.4 MHz / QPSK  
Low Channel



Bureau Veritas Consumer Products Services Ltd., Taoyuan Branch

A D T

Data: 5

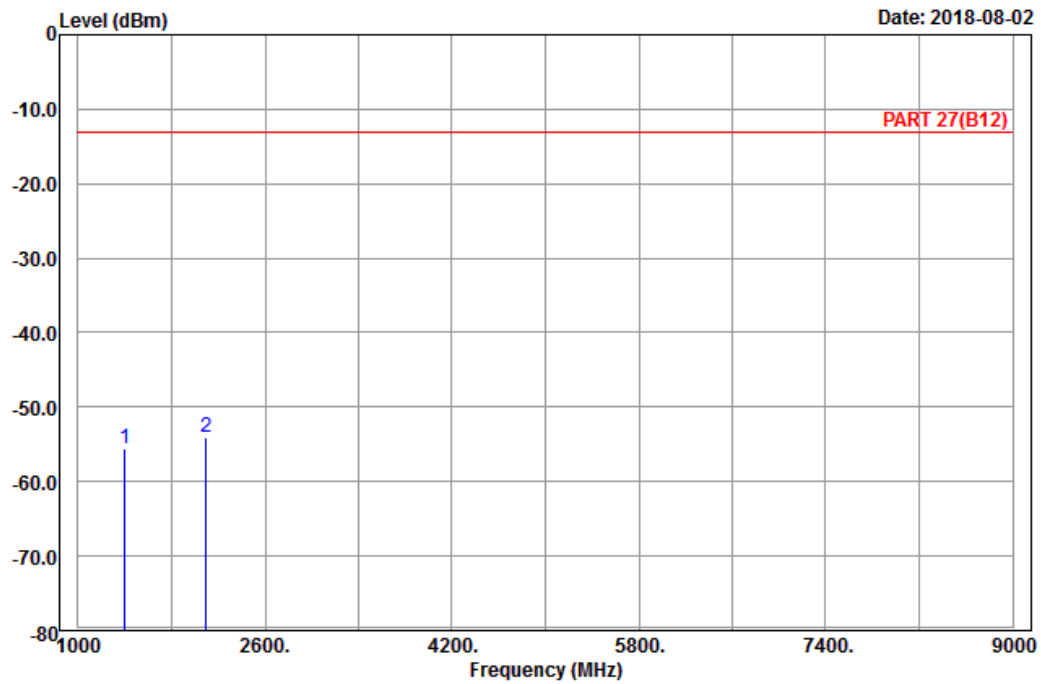

Site : 966 chamber 1  
Condition: PART 27(B12) Horizontal  
Remark : LTE\_Band 12\_Link\_CH23017  
Tested by: Karl Lee

	Read	Limit	Over				
Freq	Level	Level	Line	Limit	Factor	Remark	
MHz	dBm	dBm	dBm	dB	dB		
1	1399.40	-55.64	-61.74	-13.00	-42.64	6.10	Peak
2 pp	2099.10	-54.08	-65.01	-13.00	-41.08	10.93	Peak



A D T

Data: 6

Date: 2018-08-02

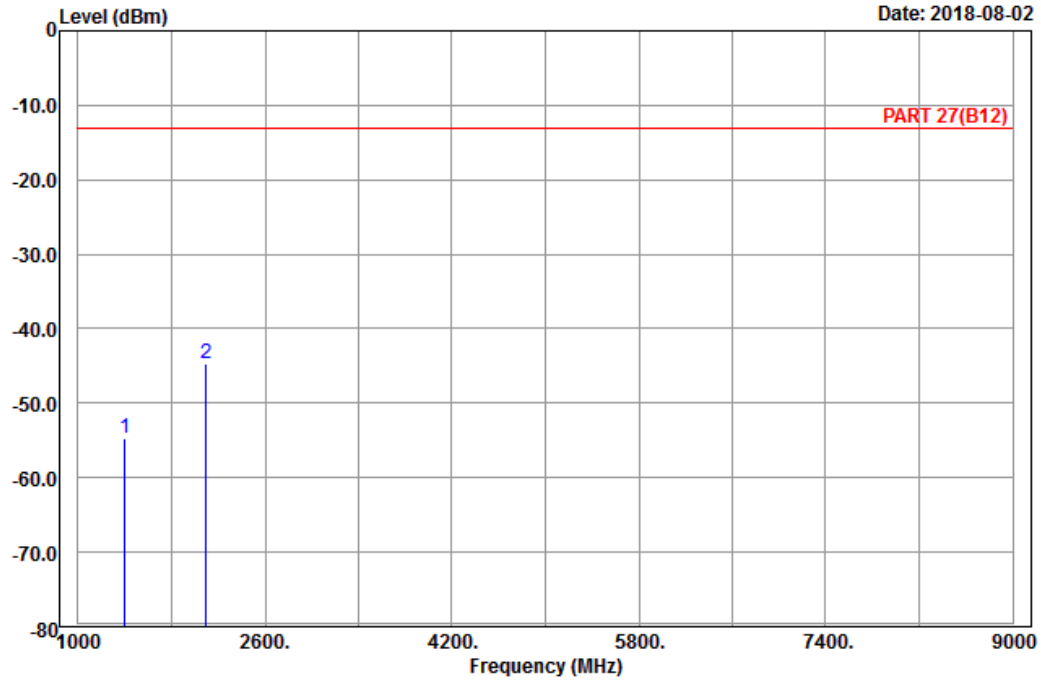

Site : 966 chamber 1  
 Condition: PART 27(B12) Vertical  
 Remark : LTE\_Band 12\_Link\_CH23017  
 Tested by: Karl Lee

	Freq	Level	Read Level	Limit Line	Over Limit	Factor	Remark
	MHz	dBm	dBm	dBm	dB	dB	
1	1399.40	-54.68	-60.78	-13.00	-41.68	6.10	Peak
2 pp	2099.10	-44.73	-55.66	-13.00	-31.73	10.93	Peak

Middle Channel



Bureau Veritas Consumer Products Services Ltd., Taoyuan Branch

A D T

Data: 5

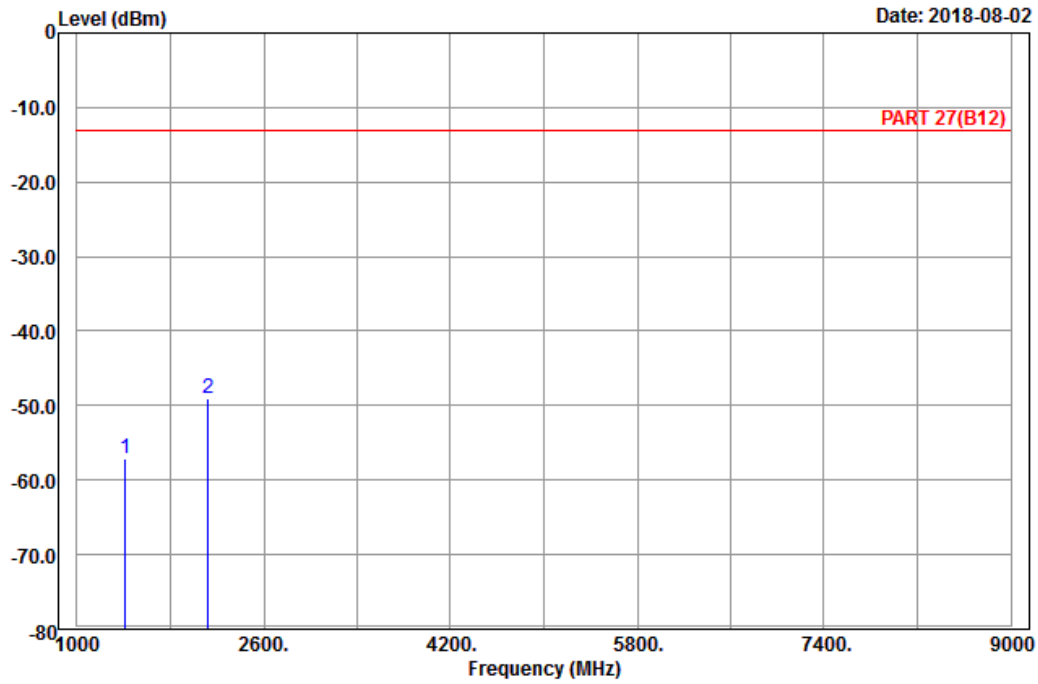

Site : 966 chamber 1  
 Condition: PART 27(B12) Horizontal  
 Remark : LTE\_Band 12\_Link\_CH23095  
 Tested by: Karl Lee

	Freq	Level	Read Level	Limit Line	Over Limit	Factor	Remark
	MHz	dBm	dBm	dBm	dB	dB	
1	1415.00	-57.01	-63.37	-13.00	-44.01	6.36	Peak
2 pp	2122.50	-49.01	-60.12	-13.00	-36.01	11.11	Peak



A D T

Data: 6

Date: 2018-08-02

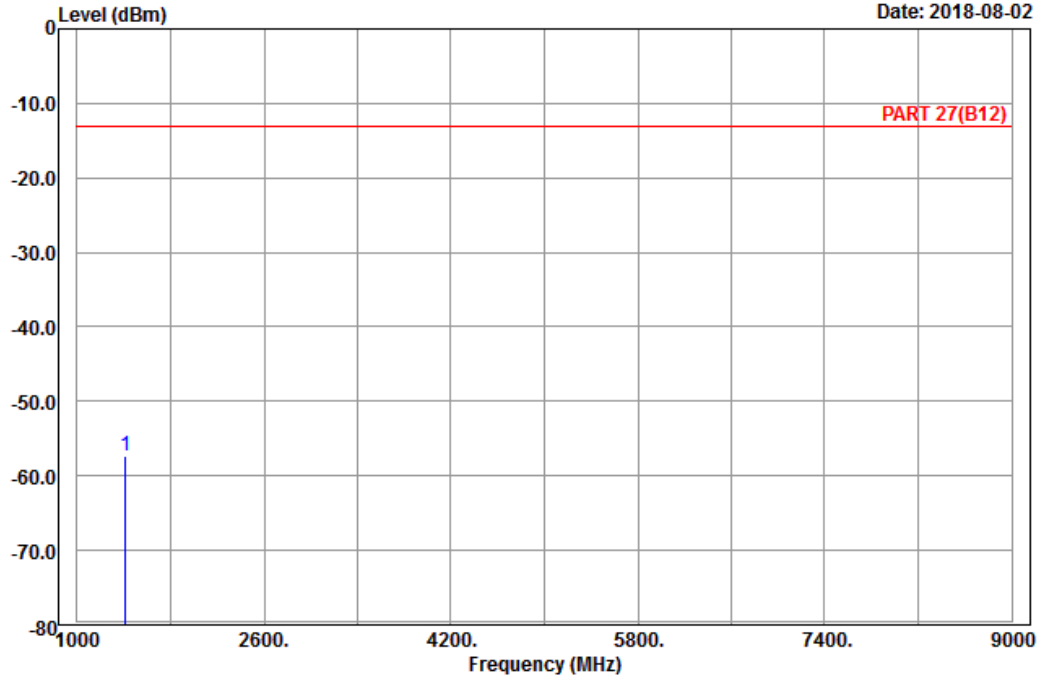

Site : 966 chamber 1  
 Condition: PART 27(B12) Vertical  
 Remark : LTE\_Band 12\_Link\_CH23095  
 Tested by: Karl Lee

	Freq	Level	Read Level	Limit Line	Over Limit	Factor	Remark
	MHz	dBm	dBm	dBm	dB	dB	
1	pp 1415.00	-57.25	-63.61	-13.00	-44.25	6.36	Peak

High Channel



Bureau Veritas Consumer Products Services Ltd., Taoyuan Branch

A D T

Data: 5

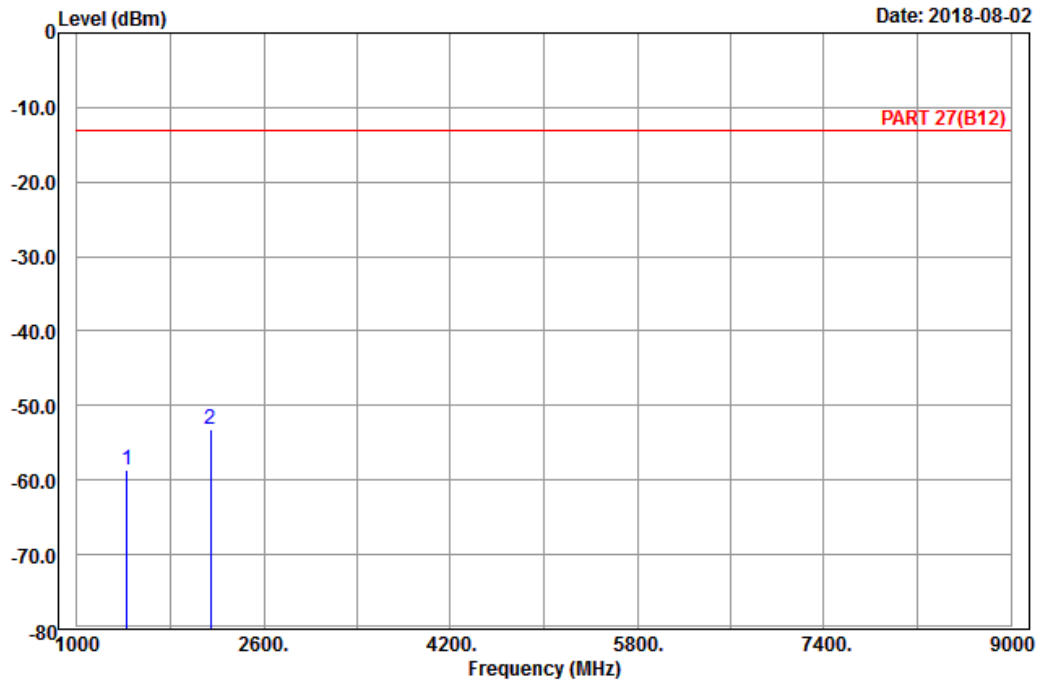

Site : 966 chamber 1  
 Condition: PART 27(B12) Horizontal  
 Remark : LTE\_Band 12\_Link\_CH23173  
 Tested by: Karl Lee

	Freq	Level	Read Level	Limit Line	Over Limit	Factor	Remark
	MHz	dBm	dBm	dBm	dB	dB	
1	1430.60	-58.65	-64.89	-13.00	-45.65	6.24	Peak
2 pp	2145.90	-53.10	-64.35	-13.00	-40.10	11.25	Peak



A D T

Data: 6

Date: 2018-08-02

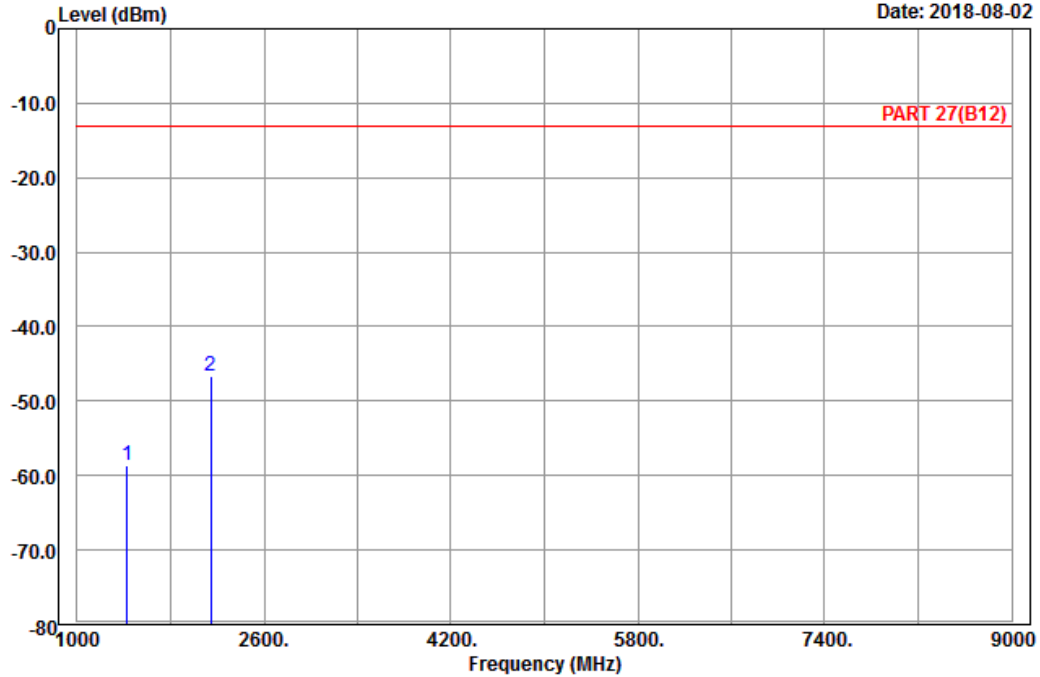

Site : 966 chamber 1  
 Condition: PART 27(B12) Vertical  
 Remark : LTE\_Band 12\_Link\_CH23173  
 Tested by: Karl Lee

	Freq	Level	Read Level	Limit Line	Over Limit	Factor	Remark
	MHz	dBm	dBm	dBm	dB	dB	
1	1430.60	-58.54	-64.78	-13.00	-45.54	6.24	Peak
2 pp	2145.90	-46.62	-57.87	-13.00	-33.62	11.25	Peak



Channel Bandwidth: 5 MHz / QPSK  
Low Channel



Bureau Veritas Consumer Products Services Ltd., Taoyuan Branch

A D T

Data: 5

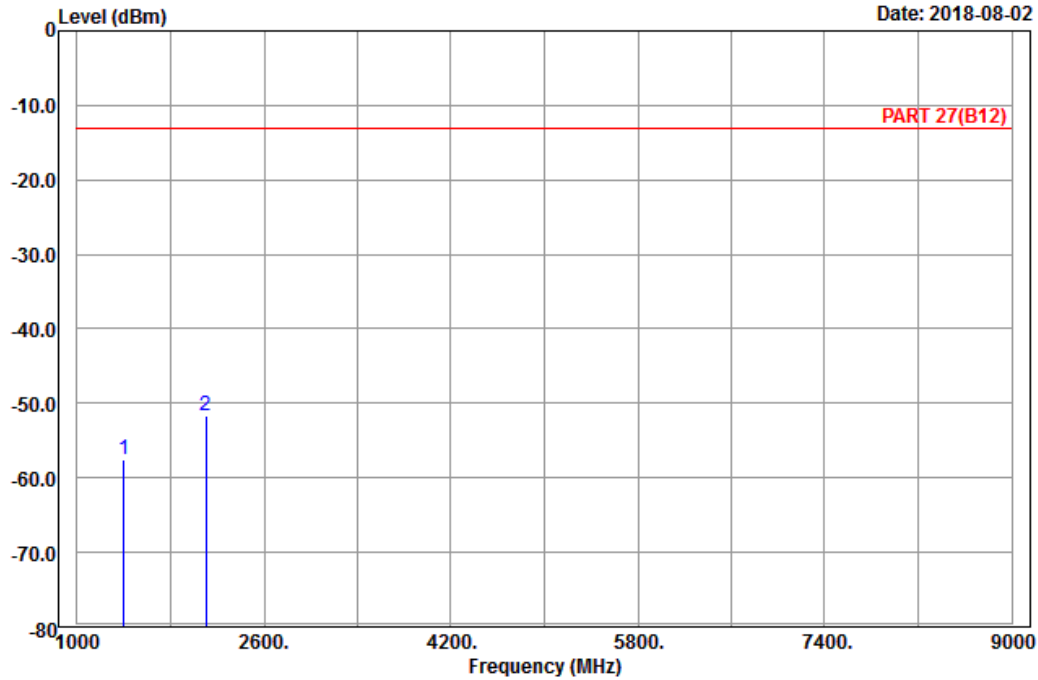

Site : 966 chamber 1  
Condition: PART 27(B12) Horizontal  
Remark : LTE\_Band 12\_Link\_CH23035  
Tested by: Karl Lee

	Freq	Level	Read Level	Limit Line	Over Limit	Factor	Remark
	MHz	dBm	dBm	dBm	dB	dB	
1	1403.00	-57.64	-63.74	-13.00	-44.64	6.10	Peak
2	pp 2104.50	-51.62	-62.55	-13.00	-38.62	10.93	Peak



Bureau Veritas Consumer Products Services Ltd., Taoyuan Branch

A D T

Data: 6

Date: 2018-08-02

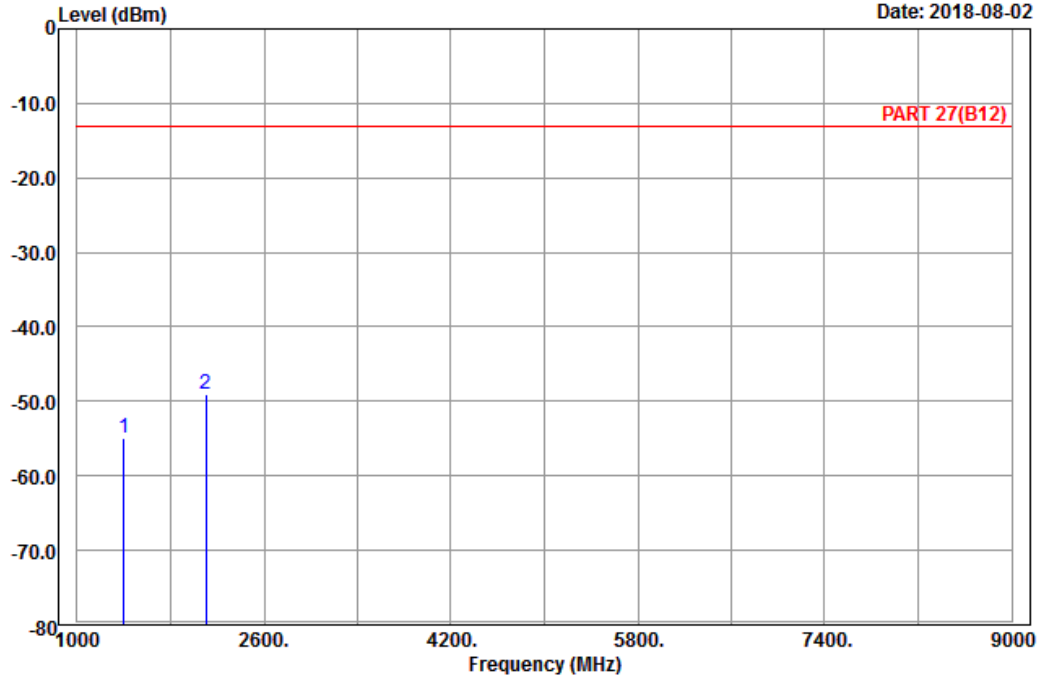

Site : 966 chamber 1  
 Condition: PART 27(B12) Vertical  
 Remark : LTE\_Band 12\_Link\_CH23035  
 Tested by: Karl Lee

	Freq	Level	Read Level	Limit Line	Over Limit	Factor	Remark
	MHz	dBm	dBm	dBm	dB	dB	
1	1403.00	-54.94	-61.04	-13.00	-41.94	6.10	Peak
2 pp	2104.50	-48.94	-59.87	-13.00	-35.94	10.93	Peak

Middle Channel



Bureau Veritas Consumer Products Services Ltd., Taoyuan Branch

A D T

Data: 5

Date: 2018-08-02

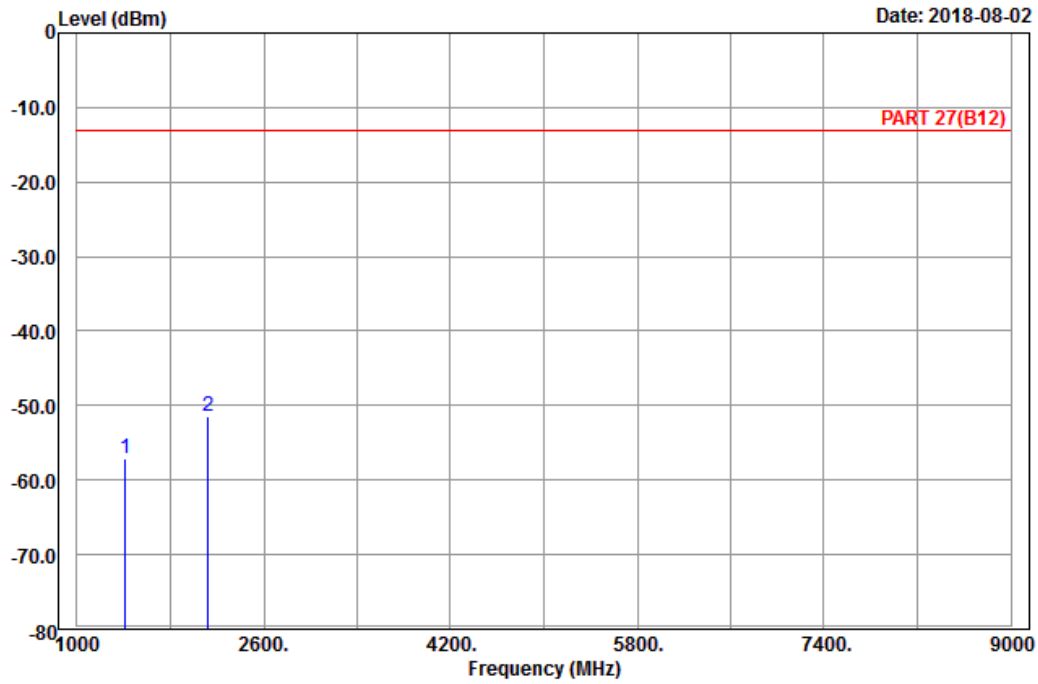

Site : 966 chamber 1  
 Condition: PART 27(B12) Horizontal  
 Remark : LTE\_Band 12\_Link\_CH23095  
 Tested by: Karl Lee

	Freq	Level	Read Level	Limit Line	Over Limit	Factor	Remark
	MHz	dBm	dBm	dBm	dB	dB	
1	1415.00	-57.10	-63.46	-13.00	-44.10	6.36	Peak
2 pp	2122.50	-51.51	-62.62	-13.00	-38.51	11.11	Peak



A D T

Data: 6

Date: 2018-08-02

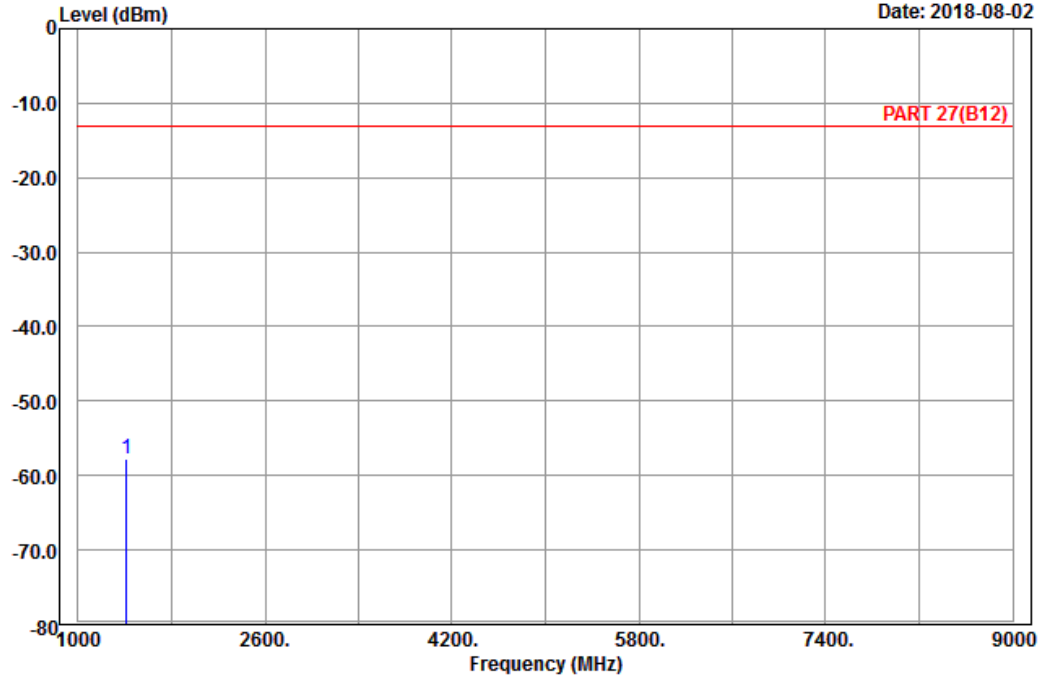

Site : 966 chamber 1  
 Condition: PART 27(B12) Vertical  
 Remark : LTE\_Band 12\_Link\_CH23095  
 Tested by: Karl Lee

	Freq	Level	Read Level	Limit Line	Over Limit	Factor	Remark
	MHz	dBm	dBm	dBm	dB	dB	
1	pp 1415.00	-57.70	-64.06	-13.00	-44.70	6.36	Peak

High Channel



Bureau Veritas Consumer Products Services Ltd., Taoyuan Branch

A D T

Data: 5

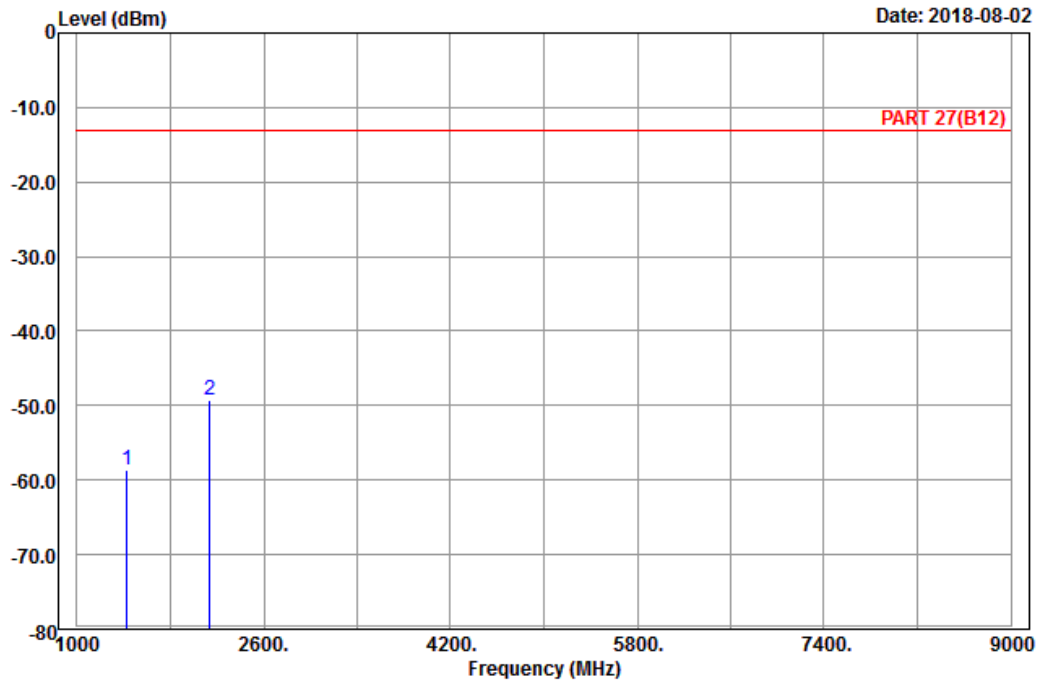

Site : 966 chamber 1  
 Condition: PART 27(B12) Horizontal  
 Remark : LTE\_Band 12\_Link\_CH23155  
 Tested by: Karl Lee

	Freq	Level	Read Level	Limit Line	Over Limit	Factor	Remark
	MHz	dBm	dBm	dBm	dB	dB	
1	1427.00	-58.57	-64.81	-13.00	-45.57	6.24	Peak
2 pp	2140.50	-49.29	-60.57	-13.00	-36.29	11.28	Peak



A D T

Data: 6

Date: 2018-08-02

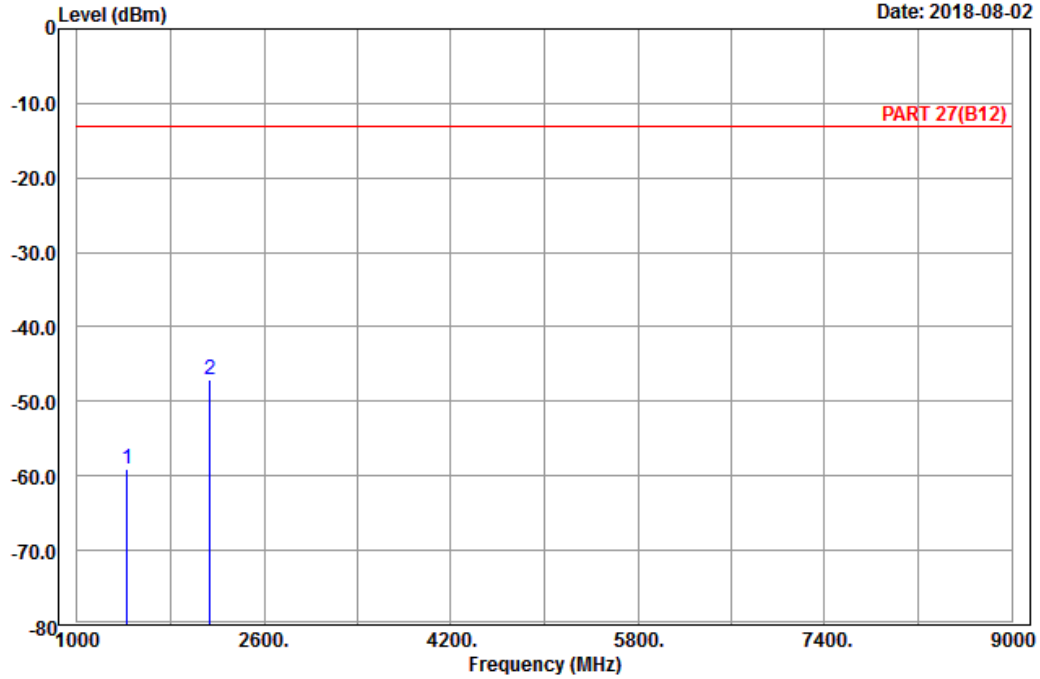

Site : 966 chamber 1  
 Condition: PART 27(B12) Vertical  
 Remark : LTE\_Band 12\_Link\_CH23155  
 Tested by: Karl Lee

	Freq	Level	Read Level	Limit Line	Over Limit	Factor	Remark
	MHz	dBm	dBm	dBm	dB	dB	
1	1427.00	-59.06	-65.30	-13.00	-46.06	6.24	Peak
2 pp	2140.50	-47.06	-58.34	-13.00	-34.06	11.28	Peak

Channel Bandwidth: 10 MHz / QPSK  
Low Channel



Bureau Veritas Consumer Products Services Ltd., Taoyuan Branch

A D T

Data: 9

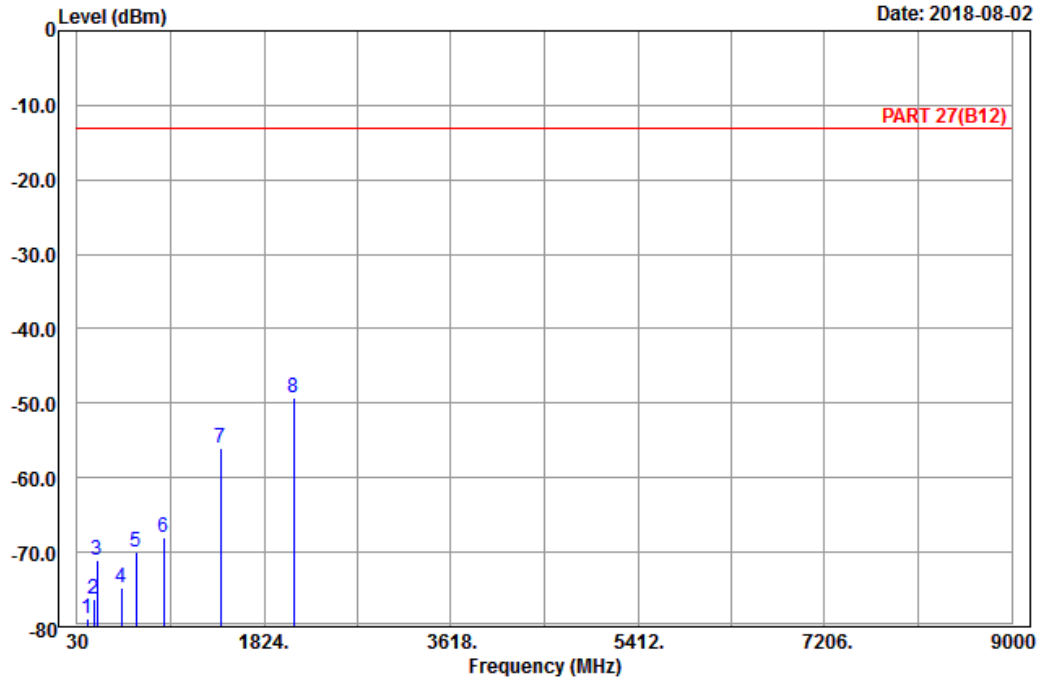

Site : 966 chamber 1  
Condition: PART 27(B12) Horizontal  
Remark : LTE\_Band 12\_Link\_CH23060  
Tested by: Karl Lee

	Freq	Level	Read Level	Limit Line	Over Limit	Factor	Remark
	MHz	dBm	dBm	dBm	dB	dB	
1	127.47	-78.91	-71.08	-13.00	-65.91	-7.83	Peak
2	187.14	-76.34	-70.65	-13.00	-63.34	-5.69	Peak
3	220.08	-71.08	-65.17	-13.00	-58.08	-5.91	Peak
4	456.80	-74.72	-70.68	-13.00	-61.72	-4.04	Peak
5	594.70	-69.98	-70.17	-13.00	-56.98	0.19	Peak
6	862.80	-67.94	-69.78	-13.00	-54.94	1.84	Peak
7	1408.00	-56.01	-62.37	-13.00	-43.01	6.36	Peak
8 pp	2112.00	-49.18	-60.29	-13.00	-36.18	11.11	Peak



Bureau Veritas Consumer Products Services Ltd., Taoyuan Branch

A D T

Data: 10

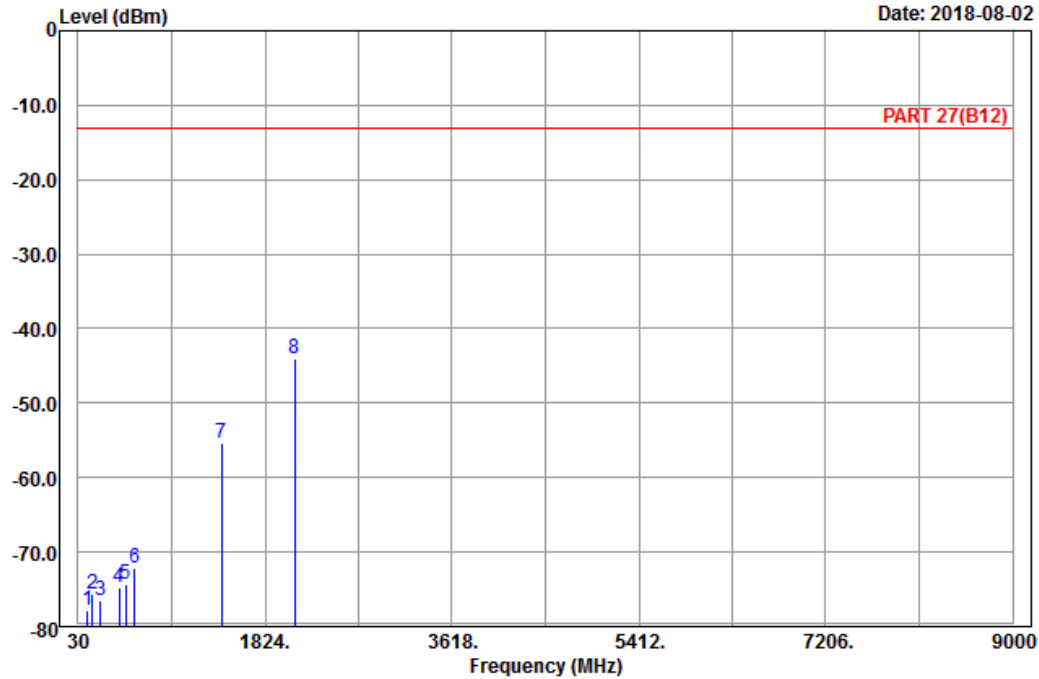

Site : 966 chamber 1  
 Condition: PART 27(B12) Vertical  
 Remark : LTE\_Band 12\_Link\_CH23060  
 Tested by: Karl Lee

	Freq	Level	Read Level	Limit Line	Over Limit	Factor	Remark
	MHz	dBm	dBm	dBm	dB	dB	
1	121.26	-77.91	-69.72	-13.00	-64.91	-8.19	Peak
2	168.24	-75.59	-68.79	-13.00	-62.59	-6.80	Peak
3	247.08	-76.48	-70.93	-13.00	-63.48	-5.55	Peak
4	426.00	-74.80	-71.49	-13.00	-61.80	-3.31	Peak
5	484.80	-74.36	-69.52	-13.00	-61.36	-4.84	Peak
6	573.70	-72.26	-71.60	-13.00	-59.26	-0.66	Peak
7	1408.00	-55.46	-61.82	-13.00	-42.46	6.36	Peak
8 pp	2112.00	-44.01	-55.12	-13.00	-31.01	11.11	Peak



Middle Channel



Bureau Veritas Consumer Products Services Ltd., Taoyuan Branch

A D T

Data: 5

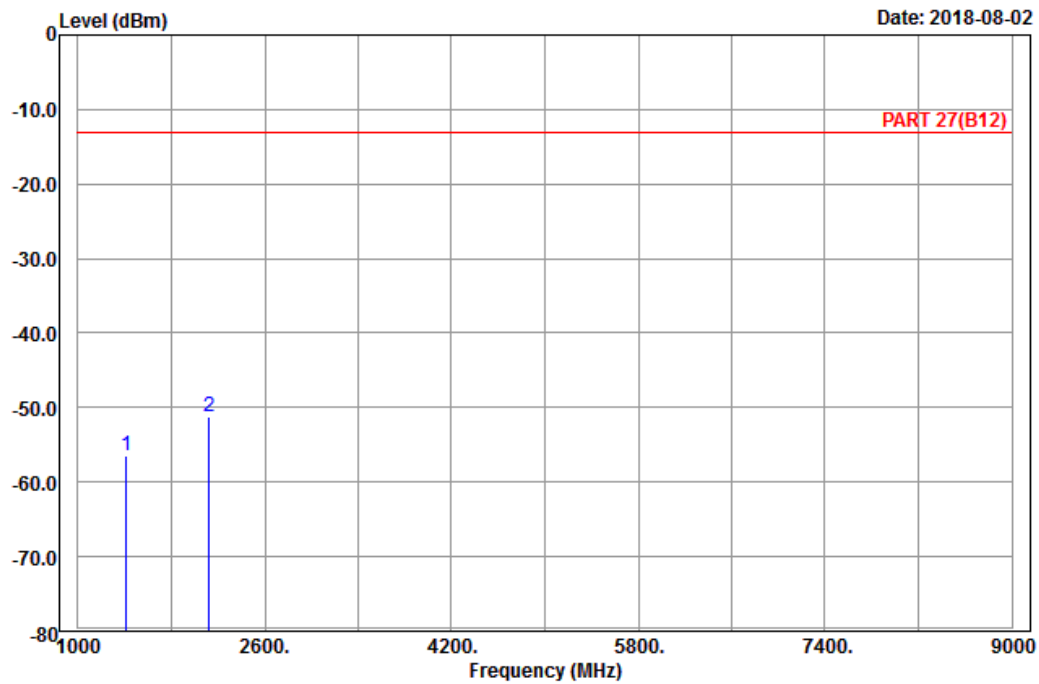

Site : 966 chamber 1  
 Condition: PART 27(B12) Horizontal  
 Remark : LTE\_Band 12\_Link\_CH23095  
 Tested by: Karl Lee

	Freq	Level	Read Level	Limit Line	Over Limit	Factor	Remark
	MHz	dBm	dBm	dBm	dB	dB	
1	1415.00	-56.46	-62.82	-13.00	-43.46	6.36	Peak
2 pp	2122.50	-51.14	-62.25	-13.00	-38.14	11.11	Peak



Bureau Veritas Consumer Products Services Ltd., Taoyuan Branch

A D T

Data: 6

Date: 2018-08-02

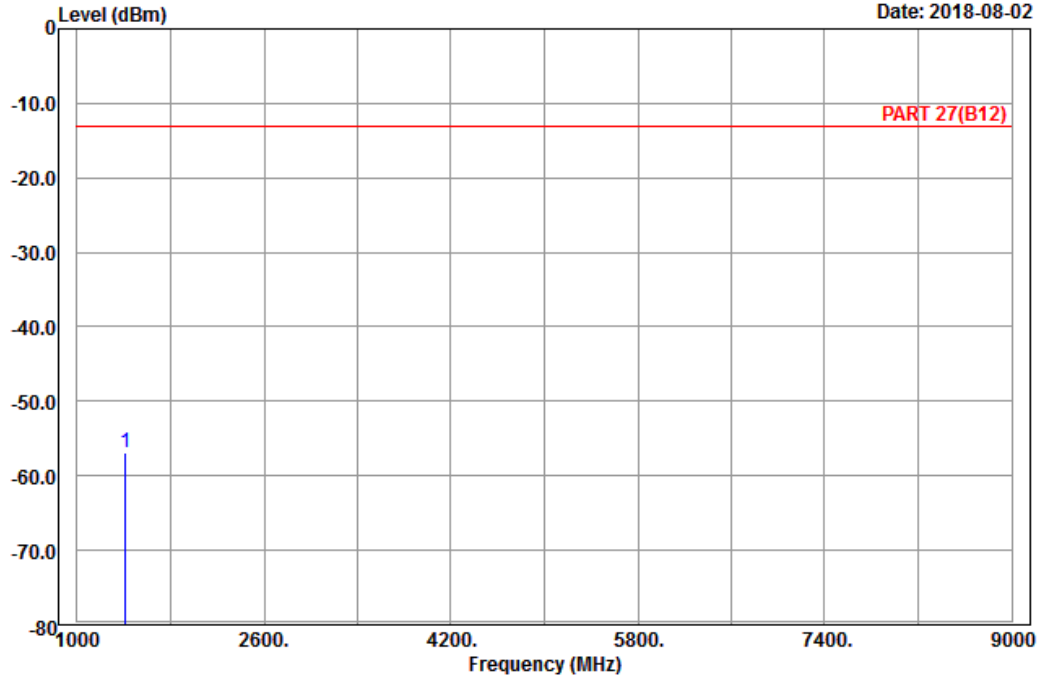

Site : 966 chamber 1  
 Condition: PART 27(B12) Vertical  
 Remark : LTE\_Band 12\_Link\_CH23095  
 Tested by: Karl Lee

	Freq	Level	Read Level	Limit Line	Over Limit	Factor	Remark
	MHz	dBm	dBm	dBm	dB	dB	
1	pp 1415.00	-56.79	-63.15	-13.00	-43.79	6.36	Peak

High Channel



Bureau Veritas Consumer Products Services Ltd., Taoyuan Branch

A D T

Data: 5

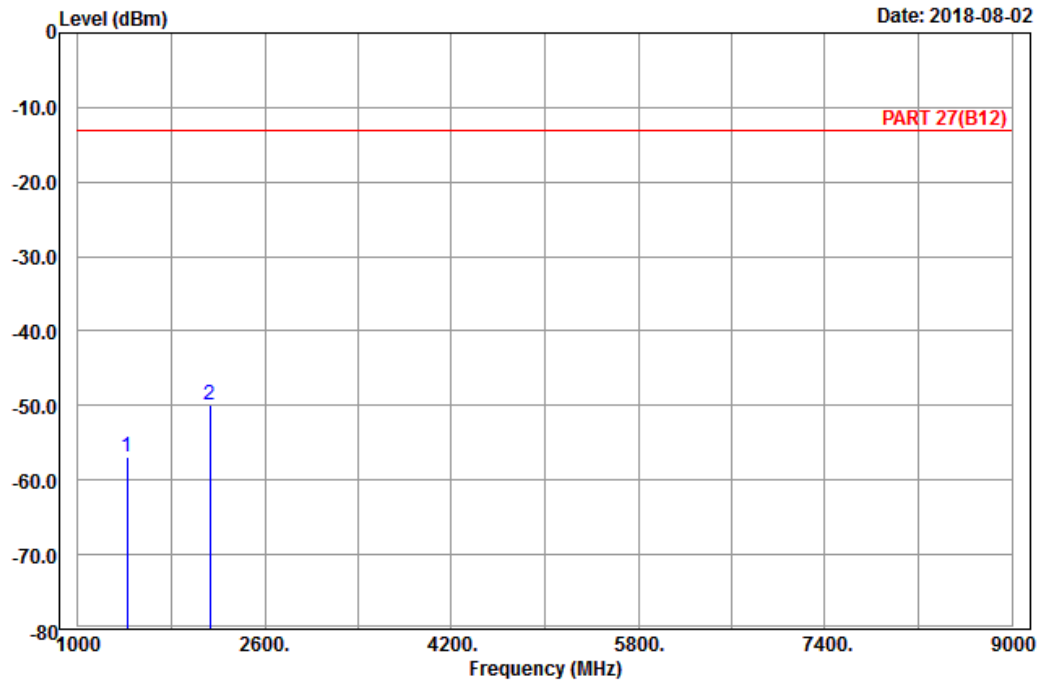

Site : 966 chamber 1  
 Condition: PART 27(B12) Horizontal  
 Remark : LTE\_Band 12\_Link\_CH23130  
 Tested by: Karl Lee

	Freq	Level	Read Level	Limit Line	Over Limit	Factor	Remark
	MHz	dBm	dBm	dBm	dB	dB	
1	1422.00	-56.96	-63.32	-13.00	-43.96	6.36	Peak
2 pp	2133.00	-49.96	-61.24	-13.00	-36.96	11.28	Peak



A D T

Data: 6

Date: 2018-08-02

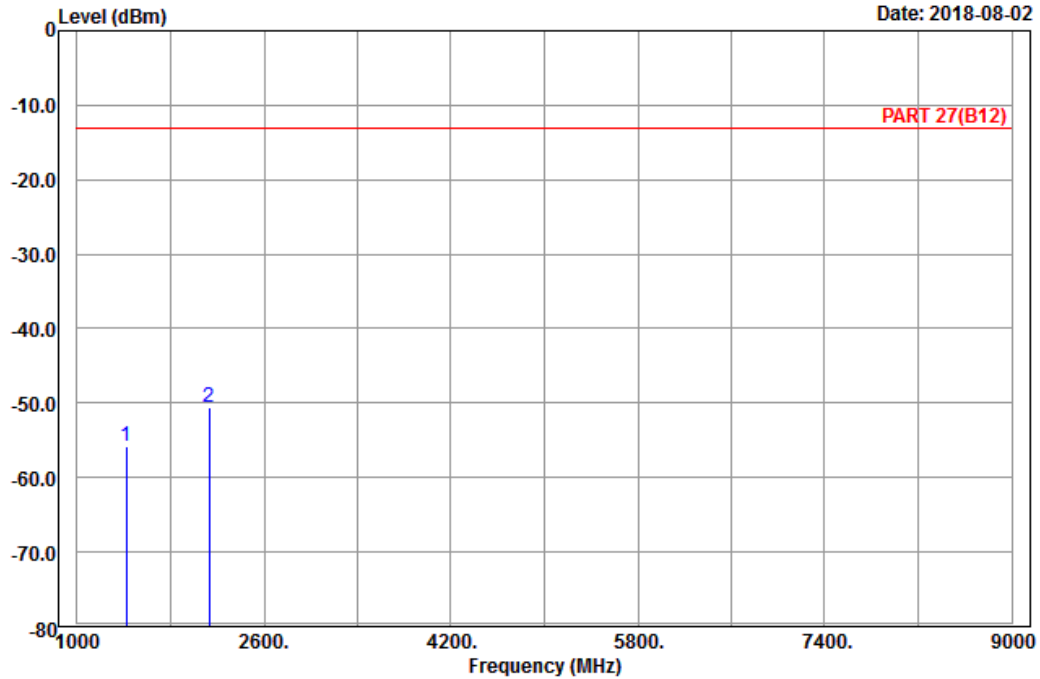

Site : 966 chamber 1  
 Condition: PART 27(B12) Vertical  
 Remark : LTE\_Band 12\_Link\_CH23130  
 Tested by: Karl Lee

	Freq	Level	Read Level	Limit Line	Over Limit	Factor	Remark
	MHz	dBm	dBm	dBm	dB	dB	
1	1422.00	-55.90	-62.26	-13.00	-42.90	6.36	Peak
2 pp	2133.00	-50.67	-61.95	-13.00	-37.67	11.28	Peak

LTE Band 13  
Channel Bandwidth: 5 MHz / QPSK  
Low Channel



Bureau Veritas Consumer Products Services Ltd., Taoyuan Branch

A D T

Data: 5

Date: 2018-08-02

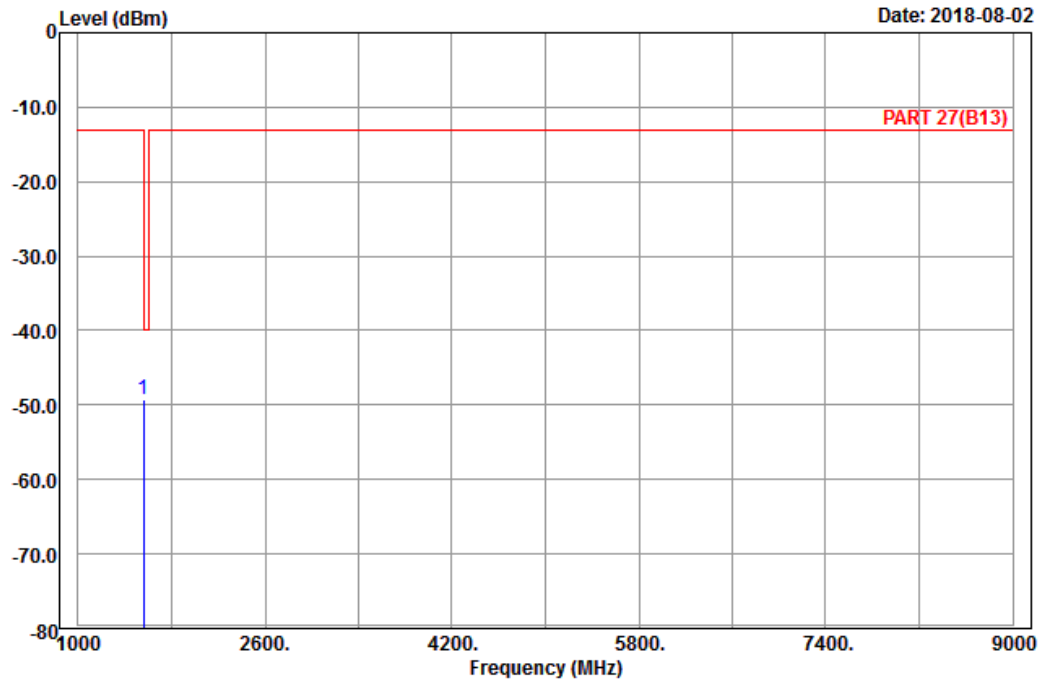

Site : 966 chamber 1  
Condition: PART 27(B13) Horizontal  
Remark : LTE\_Band 13\_Link\_CH23205  
Tested by: Karl Lee

	Read	Limit	Over			
Freq	Level	Level	Line	Limit	Factor	Remark
MHz	dBm	dBm	dBm	dB	dB	
1 pp 1559.00	-49.24	-56.10	-40.00	-9.24	6.86	Peak



Bureau Veritas Consumer Products Services Ltd., Taoyuan Branch

A D T

Data: 6

Date: 2018-08-02

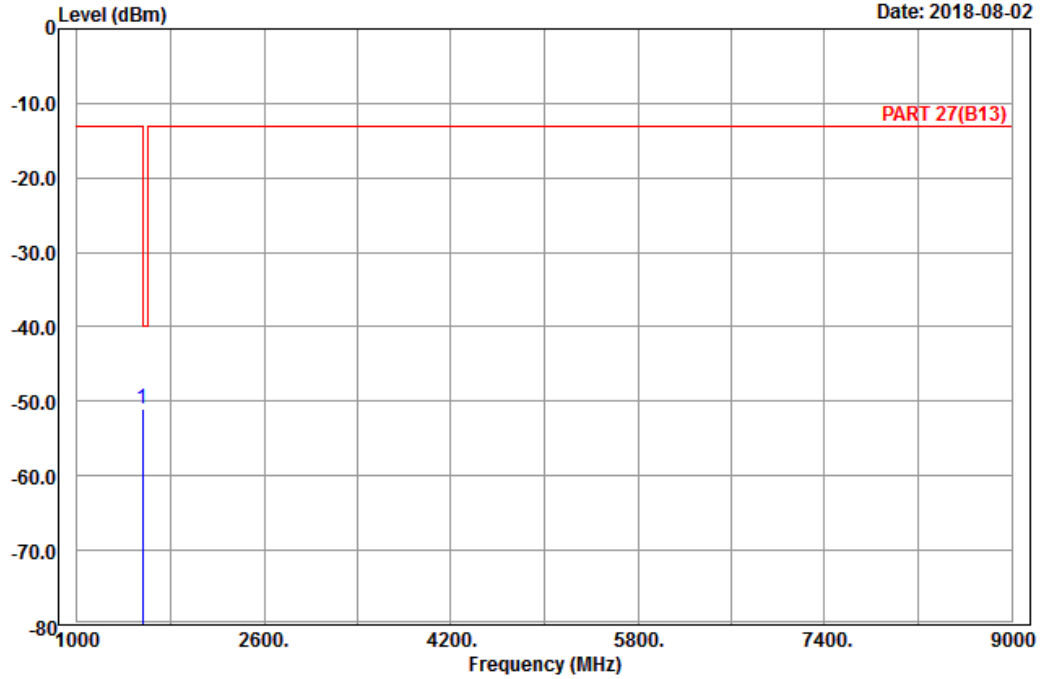

Site : 966 chamber 1  
 Condition: PART 27(B13) Vertical  
 Remark : LTE\_Band 13\_Link\_CH23205  
 Tested by: Karl Lee

	Freq	Level	Read Level	Limit Line	Over Limit	Factor	Remark
	MHz	dBm	dBm	dBm	dB	dB	
1	pp 1559.00	-51.11	-57.97	-40.00	-11.11	6.86	Peak

Middle Channel



Bureau Veritas Consumer Products Services Ltd., Taoyuan Branch

A D T

Data: 5

Date: 2018-08-02

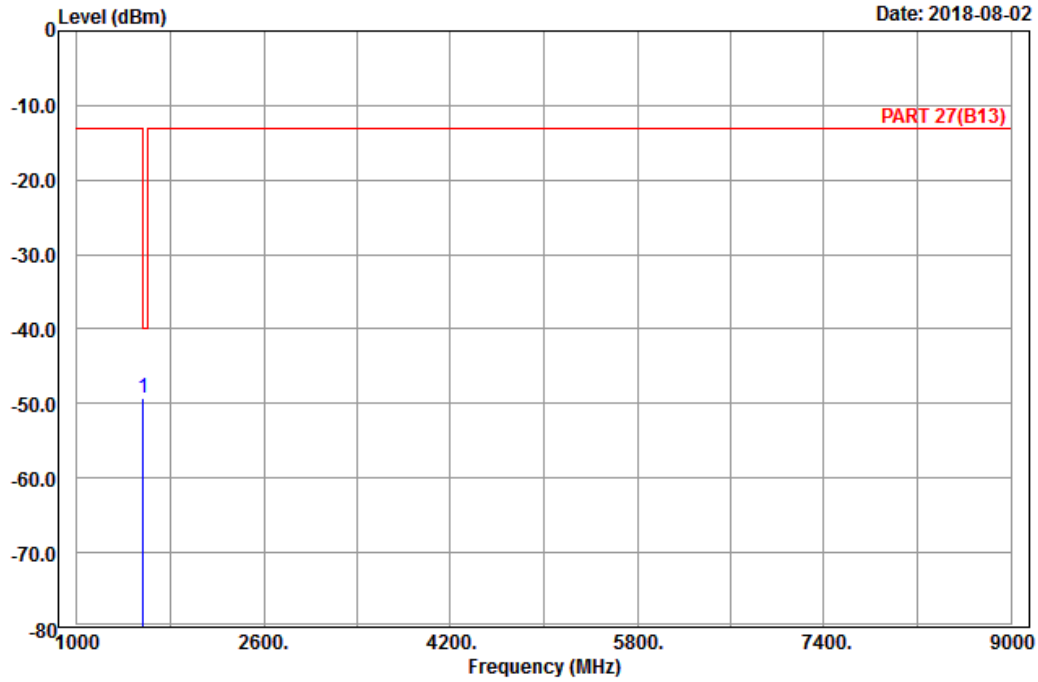

Site : 966 chamber 1  
 Condition: PART 27(B13) Horizontal  
 Remark : LTE\_Band 13\_Link\_CH23230  
 Tested by: Karl Lee

	Freq	Level	Read Level	Limit Line	Over Limit	Factor	Remark
	MHz	dBm	dBm	dBm	dB	dB	
1	pp 1564.00	-49.19	-56.05	-40.00	-9.19	6.86	Peak



Bureau Veritas Consumer Products Services Ltd., Taoyuan Branch

A D T

Data: 6

Date: 2018-08-02

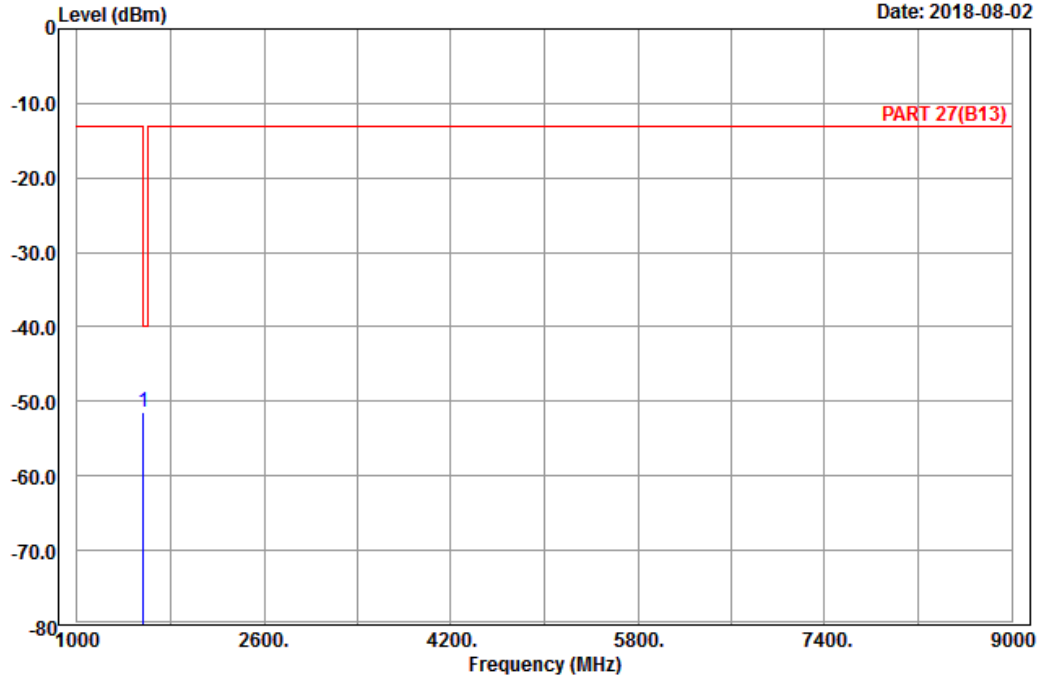

Site : 966 chamber 1  
 Condition: PART 27(B13) Vertical  
 Remark : LTE\_Band 13\_Link\_CH23230  
 Tested by: Karl Lee

	Freq	Level	Read Level	Limit Line	Over Limit	Factor	Remark
	MHz	dBm	dBm	dBm	dB	dB	
1	pp 1564.00	-51.40	-58.26	-40.00	-11.40	6.86	Peak



High Channel



Bureau Veritas Consumer Products Services Ltd., Taoyuan Branch

A D T

Data: 5

Date: 2018-08-03

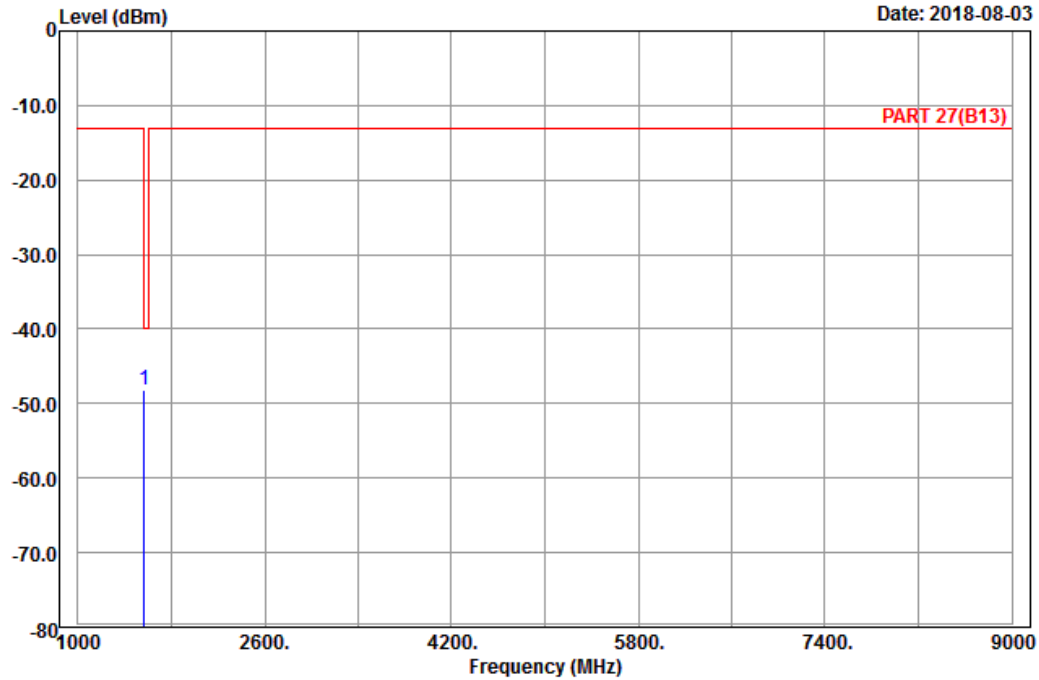

Site : 966 chamber 1  
 Condition: PART 27(B13) Horizontal  
 Remark : LTE\_Band 13\_Link\_CH23255  
 Tested by: Karl Lee

	Read	Limit	Over			
Freq	Level	Level	Line	Limit	Factor	Remark
MHz	dBm	dBm	dBm	dB	dB	
1 pp 1569.00	-48.11	-55.15	-40.00	-8.11	7.04	Peak



A D T

Data: 6

Date: 2018-08-03

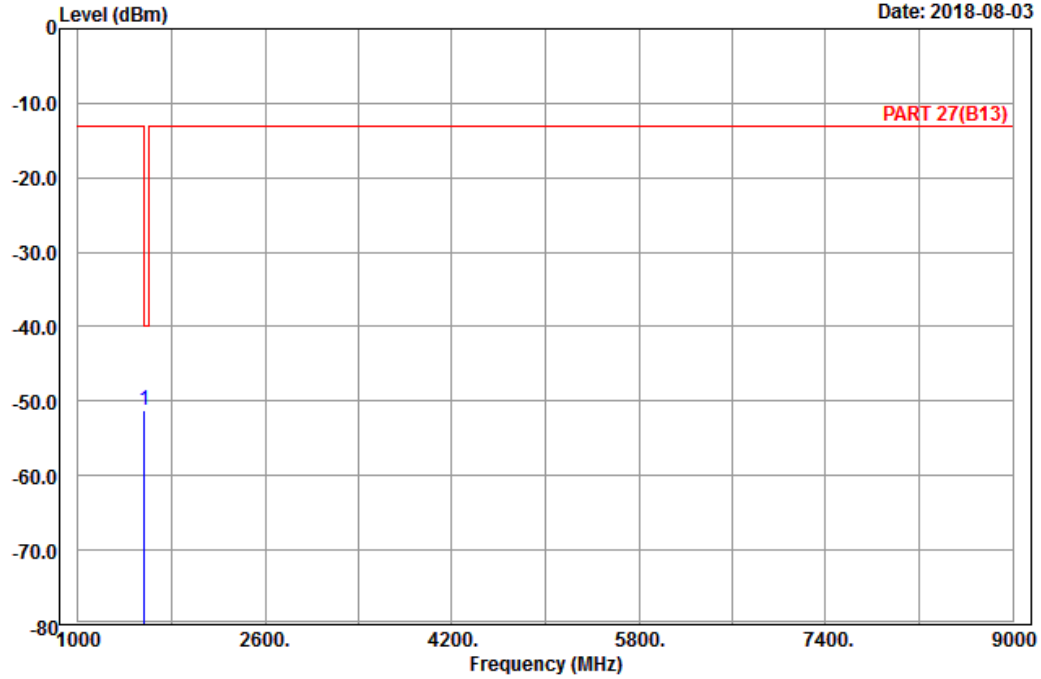

Site : 966 chamber 1  
 Condition: PART 27(B13) Vertical  
 Remark : LTE\_Band 13\_Link\_CH23255  
 Tested by: Karl Lee

	Freq	Level	Read Level	Limit Line	Over Limit	Factor	Remark
	MHz	dBm	dBm	dBm	dB	dB	
1	pp 1569.00	-51.14	-58.18	-40.00	-11.14	7.04	Peak

Channel Bandwidth: 10 MHz / QPSK  
Middle Channel



Bureau Veritas Consumer Products Services Ltd., Taoyuan Branch

A D T

Data: 9

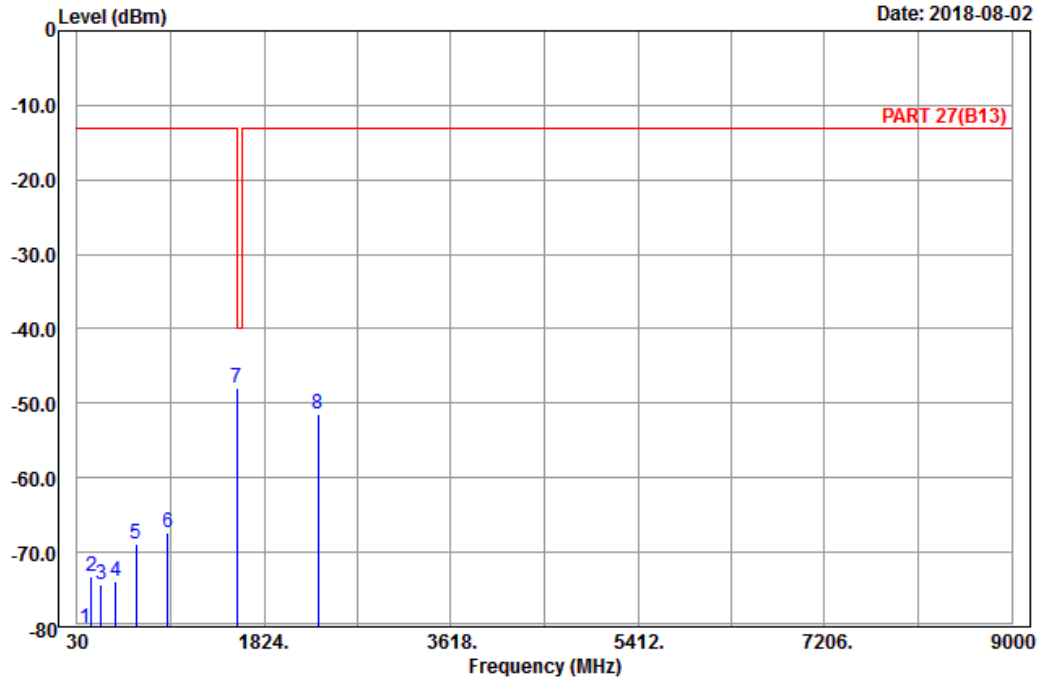

Site : 966 chamber 1  
Condition: PART 27(B13) Horizontal  
Remark : LTE\_Band 13\_Link\_CH23230  
Tested by: Karl Lee

	Freq	Level	Read Level	Limit Line	Over Limit	Factor	Remark
	MHz	dBm	dBm	dBm	dB	dB	
1	108.30	-80.13	-71.06	-13.00	-67.13	-9.07	Peak
2	164.73	-73.22	-66.03	-13.00	-60.22	-7.19	Peak
3	263.55	-74.42	-68.79	-13.00	-61.42	-5.63	Peak
4	403.60	-73.86	-71.03	-13.00	-60.86	-2.83	Peak
5	598.20	-68.84	-69.19	-13.00	-55.84	0.35	Peak
6	900.60	-67.37	-70.30	-13.00	-54.37	2.93	Peak
7 pp	1564.00	-48.05	-54.91	-40.00	-8.05	6.86	Peak
8	2346.00	-51.44	-62.38	-13.00	-38.44	10.94	Peak



Bureau Veritas Consumer Products Services Ltd., Taoyuan Branch

A D T

Data: 10

Date: 2018-08-02

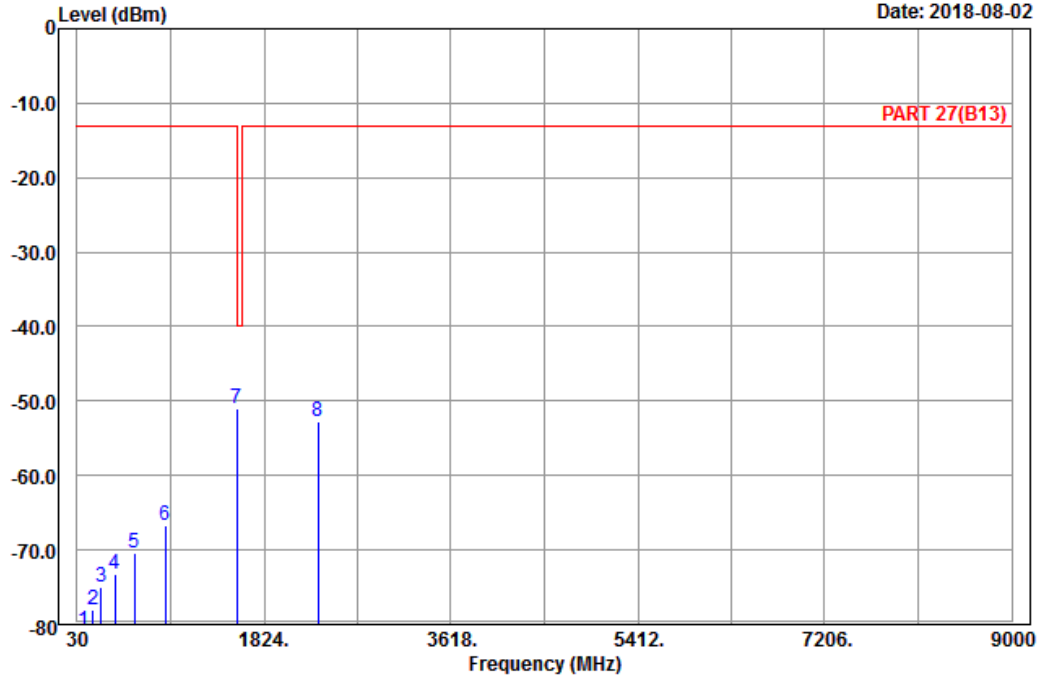

Site : 966 chamber 1  
 Condition: PART 27(B13) Vertical  
 Remark : LTE\_Band 13\_Link\_CH23230  
 Tested by: Karl Lee

	Freq	Level	Read Level	Limit Line	Over Limit	Factor	Remark
	MHz	dBm	dBm	dBm	dB	dB	
1	98.04	-80.80	-70.57	-13.00	-67.80	-10.23	Peak
2	185.52	-77.94	-72.29	-13.00	-64.94	-5.65	Peak
3	261.66	-74.89	-69.28	-13.00	-61.89	-5.61	Peak
4	395.90	-73.19	-70.24	-13.00	-60.19	-2.95	Peak
5	579.30	-70.36	-69.90	-13.00	-57.36	-0.46	Peak
6	878.90	-66.66	-68.94	-13.00	-53.66	2.28	Peak
7 pp	1564.00	-50.91	-57.77	-40.00	-10.91	6.86	Peak
8	2346.00	-52.80	-63.74	-13.00	-39.80	10.94	Peak

## 5 Pictures of Test Arrangements

Please refer to the attached file (Test Setup Photo).

## Appendix – Information on the Testing Laboratories

We, Bureau Veritas Consumer Products Services (H.K.) Ltd., Taoyuan Branch, were founded in 1988 to provide our best service in EMC, Radio, Telecom and Safety consultation. Our laboratories are FCC recognized accredited test firms and accredited according to ISO/IEC 17025.

If you have any comments, please feel free to contact us at the following:

**Linko EMC/RF Lab**

Tel: 886-2-26052180

Fax: 886-2-26051924

**Hsin Chu EMC/RF/Telecom Lab**

Tel: 886-3-6668565

Fax: 886-3-6668323

**Hwa Ya EMC/RF/Safety**

Tel: 886-3-3183232

Fax: 886-3-3270892

**Email:** [service.adt@tw.bureauveritas.com](mailto:service.adt@tw.bureauveritas.com)

**Web Site:** [www.bureauveritas-adt.com](http://www.bureauveritas-adt.com)

The address and road map of all our labs can be found in our web site also.

--- END ---