

# FCC SAR Test Report

**Report No.** : SA170927C14  
**Applicant** : Trimble Navigation Limited  
**Address** : 345 SW Avery Ave Corvallis, Oregon, United States, 97333  
**Product** : Radio Module  
**FCC ID** : S9E-EM7455  
**Brand** : Trimble  
**Model No.** : EM7455  
**Standards** : FCC 47 CFR Part 2 (2.1093), IEEE C95.1:1992, IEEE Std 1528:2013  
 KDB 865664 D01 v01r04, KDB 865664 D02 v01r02  
 KDB 248227 D01 v02r02, KDB 447498 D01 v06,  
 KDB 941225 D01 v03r01, KDB 941225 D05 v02r05  
**Sample Received Date** : Sep. 27, 2017  
**Date of Testing** : Oct. 19, 2017 ~ Oct. 28, 2017  
**Lab Address** : No. 47-2, 14th Ling, Chia Pau Vil., Lin Kou Dist., New Taipei City, Taiwan, R.O.C.  
**Test Location** : No. 19, Hwa Ya 2nd Rd, Wen Hwa Vil, Kwei Shan Dist., Taoyuan City 33383, Taiwan (R.O.C)

**CERTIFICATION:** The above equipment have been tested by **Bureau Veritas Consumer Products Services (H.K.) Ltd., Taoyuan Branch – Lin Kou Laboratories**, and found compliance with the requirement of the above standards. The test record, data evaluation & Equipment Under Test (EUT) configurations represented herein are true and accurate accounts of the measurements of the sample’s SAR characteristics under the conditions specified in this report. It should not be reproduced except in full, without the written approval of our laboratory. The client should not use it to claim product certification, approval, or endorsement by TAF or any government agencies.

**Prepared By :** Rona Chen  
 Rona Chen / Specialist

**Approved By :** Eli Hsu  
 Eli Hsu / Senior Engineer



FCC Accredited No.: TW0003

This report is for your exclusive use. Any copying or replication of this report to or for any other person or entity, or use of our name or trademark, is permitted only with our prior written permission. This report sets forth our findings solely with respect to the test samples identified herein. The results set forth in this report are not indicative or representative of the quality or characteristics of the lot from which a test sample was taken or any similar or identical product unless specifically and expressly noted. Our report includes all of the tests requested by you and the results thereof based upon the information that you provided to us. You have 60 days from date of issuance of this report to notify us of any material error or omission caused by our negligence, provided, however, that such notice shall be in writing and shall specifically address the issue you wish to raise. A failure to raise such issue within the prescribed time shall constitute your unqualified acceptance of the completeness of this report, the tests conducted and the correctness of the report contents. Unless specific mention, the uncertainty of measurement has been explicitly taken into account to declare the compliance or non-compliance to the specification.

## Table of Contents

Release Control Record .....	3
1. Summary of Maximum SAR Value .....	4
2. Description of Equipment Under Test .....	5
3. SAR Measurement System .....	6
3.1 Definition of Specific Absorption Rate (SAR) .....	6
3.2 SPEAG DASY52 System .....	6
3.2.1 Robot.....	7
3.2.2 Probes.....	8
3.2.3 Data Acquisition Electronics (DAE) .....	8
3.2.4 Phantoms .....	9
3.2.5 Device Holder.....	10
3.2.6 System Validation Dipoles.....	10
3.2.7 Tissue Simulating Liquids.....	11
3.3 SAR System Verification .....	14
3.4 SAR Measurement Procedure .....	15
3.4.1 Area & Zoom Scan Procedure .....	15
3.4.2 Volume Scan Procedure.....	15
3.4.3 Power Drift Monitoring.....	16
3.4.4 Spatial Peak SAR Evaluation .....	16
3.4.5 SAR Averaged Methods .....	16
4. SAR Measurement Evaluation .....	17
4.1 EUT Configuration and Setting.....	17
4.2 EUT Testing Position .....	23
4.2.1 SAR Test Exclusion Evaluations .....	23
4.3 Tissue Verification .....	27
4.4 System Validation.....	27
4.5 System Verification.....	28
4.6 Maximum Output Power.....	29
4.6.1 Maximum Target Conducted Power .....	29
4.6.2 Measured Conducted Power Result.....	32
4.7 SAR Testing Results .....	44
4.7.1 SAR Test Reduction Considerations .....	44
4.7.2 SAR Results for Extremity Exposure Condition (Test Separation Distance is 0 mm) .....	46
4.7.3 SAR Measurement Variability.....	48
4.7.4 Simultaneous Multi-band Transmission Evaluation .....	48
5. Calibration of Test Equipment.....	58
6. Measurement Uncertainty.....	59
7. Information on the Testing Laboratories.....	63
Appendix A. SAR Plots of System Verification	
Appendix B. SAR Plots of SAR Measurement	
Appendix C. Calibration Certificate for Probe and Dipole	
Appendix D. Photographs of EUT and Setup	



**1. Summary of Maximum SAR Value**

Equipment Class	Mode	Highest SAR-10g Extremity Tested at 0 mm (W/kg)
PCB	WCDMA II	0.95
	WCDMA IV	0.82
	WCDMA V	0.67
	LTE 2	1.03
	LTE 4	0.89
	LTE 5	0.71
	LTE 7	1.14
	LTE 12	0.41
	LTE 13	0.32
	LTE 25	0.90
	LTE 26	0.58
	LTE 30	0.60
LTE 41	0.89	
DTS	2.4G WLAN	1.08
NII	5.3G WLAN	0.34
	5.6G WLAN	0.54
	5.8G WLAN	0.42
DSS	Bluetooth	0.02
Highest Simultaneous Transmission SAR		Extremity
		2.14

**Note:**

1. The SAR criteria (**Head & Body: SAR-1g 1.6 W/kg, and Extremity: SAR-10g 4.0 W/kg**) for general population / uncontrolled exposure is specified in FCC 47 CFR part 2 (2.1093) and ANSI/IEEE C95.1-1992.

## 2. Description of Equipment Under Test

<b>EUT Type</b>	Radio Module
<b>FCC ID</b>	S9E-EM7455
<b>Brand Name</b>	Trimble
<b>Model Name</b>	EM7455
<b>Tx Frequency Bands (Unit: MHz)</b>	WCDMA Band II : 1852.4 ~ 1907.6 WCDMA Band IV : 1712.4 ~ 1752.6 WCDMA Band V : 826.4 ~ 846.6 LTE Band 2 : 1850.7 ~ 1909.3 (BW: 1.4M, 3M, 5M, 10M, 15M, 20M) LTE Band 4 : 1710.7 ~ 1754.3 (BW: 1.4M, 3M, 5M, 10M, 15M, 20M) LTE Band 5 : 824.7 ~ 848.3 (BW: 1.4M, 3M, 5M, 10M) LTE Band 7 : 2502.5 ~ 2567.5 (BW: 5M, 10M, 15M, 20M) LTE Band 12 : 699.7 ~ 715.3 (BW: 1.4M, 3M, 5M, 10M) LTE Band 13 : 779.5 ~ 784.5 (BW: 5M, 10M) LTE Band 25 : 1850.7 ~ 1914.3 (BW: 1.4M, 3M, 5M, 10M, 15M, 20M) LTE Band 26 : 814.7 ~ 848.3 (BW: 1.4M, 3M, 5M, 10M, 15M) LTE Band 29 : 717 ~ 728 (Rx only) LTE Band 30 : 2307.5 ~ 2312.5 (BW: 5M, 10M) LTE Band 41 : 2498.5 ~ 2687.5 (BW: 5M, 10M, 15M, 20M)
<b>Uplink Modulations</b>	WCDMA : QPSK LTE : QPSK, 16QAM
<b>Maximum Tune-up Conducted Power (Unit: dBm)</b>	Please refer to section 4.6.1 of this report
<b>Antenna Type</b>	PIFA Antenna
<b>EUT Stage</b>	Production Unit

**Note:**

1. The EUT is authorized for use in specific End-product. Please refer to below for more details.

Product	Brand Name	Model Name
Handheld PC	Trimble	121300

2. The End-product may collocate with following module.

Product	Brand Name	Model Name
WiFi / BT Module	Qualcomm Atheros	QCNFA364A
Specification of WLAN Module		
<b>Tx Frequency Bands (Unit: MHz)</b>	WLAN : 2412 ~ 2462, 5180 ~ 5240, 5260 ~ 5320, 5500 ~ 5700, 5745 ~ 5825 Bluetooth : 2402 ~ 2480	
<b>Uplink Modulations</b>	802.11b : DSSS 802.11a/g/n/ac : OFDM Bluetooth : GFSK, π/4-DQPSK, 8-DPSK	
<b>Maximum Tune-up Conducted Power (Unit: dBm)</b>	Please refer to section 4.6.1 of this report.	

3. The above EUT information is declared by manufacturer and for more detailed features description please refers to the manufacturer's specifications or User's Manual.

**List of Accessory of End-product:**

<b>Battery</b>	<b>Brand Name</b>	Trimble
	<b>Model Name</b>	121300
	<b>Power Rating</b>	7.27Vdc, 3150mAh, 22.9Wh
	<b>Type</b>	Li-ion
<b>WLAN / BT Module</b>	<b>Brand Name</b>	Qualcomm Atheros
	<b>Model Name</b>	QCNFA364A

### **3. SAR Measurement System**

#### **3.1 Definition of Specific Absorption Rate (SAR)**

SAR is related to the rate at which energy is absorbed per unit mass in an object exposed to a radio field. The SAR distribution in a biological body is complicated and is usually carried out by experimental techniques or numerical modeling. The standard recommends limits for two tiers of groups, occupational/controlled and general population/uncontrolled, based on a person's awareness and ability to exercise control over his or her exposure. In general, occupational/controlled exposure limits are higher than the limits for general population/uncontrolled.

The SAR definition is the time derivative (rate) of the incremental energy (dW) absorbed by (dissipated in) an incremental mass (dm) contained in a volume element (dv) of a given density ( $\rho$ ). The equation description is as below:

$$\text{SAR} = \frac{d}{dt} \left( \frac{dW}{dm} \right) = \frac{d}{dt} \left( \frac{dW}{\rho dv} \right)$$

SAR is expressed in units of Watts per kilogram (W/kg)

SAR measurement can be related to the electrical field in the tissue by

$$\text{SAR} = \frac{\sigma |E|^2}{\rho}$$

Where:  $\sigma$  is the conductivity of the tissue,  $\rho$  is the mass density of the tissue and E is the RMS electrical field strength.

#### **3.2 SPEAG DASY52 System**

DASY52 system consists of high precision robot, probe alignment sensor, phantom, robot controller, controlled measurement server and near-field probe. The robot includes six axes that can move to the precision position of the DASY52 software defined. The DASY52 software can define the area that is detected by the probe. The robot is connected to controlled box. Controlled measurement server is connected to the controlled robot box. The DAE includes amplifier, signal multiplexing, AD converter, offset measurement and surface detection. It is connected to the Electro-optical coupler (ECO). The ECO performs the conversion from the optical into digital electric signal of the DAE and transfers data to the PC.

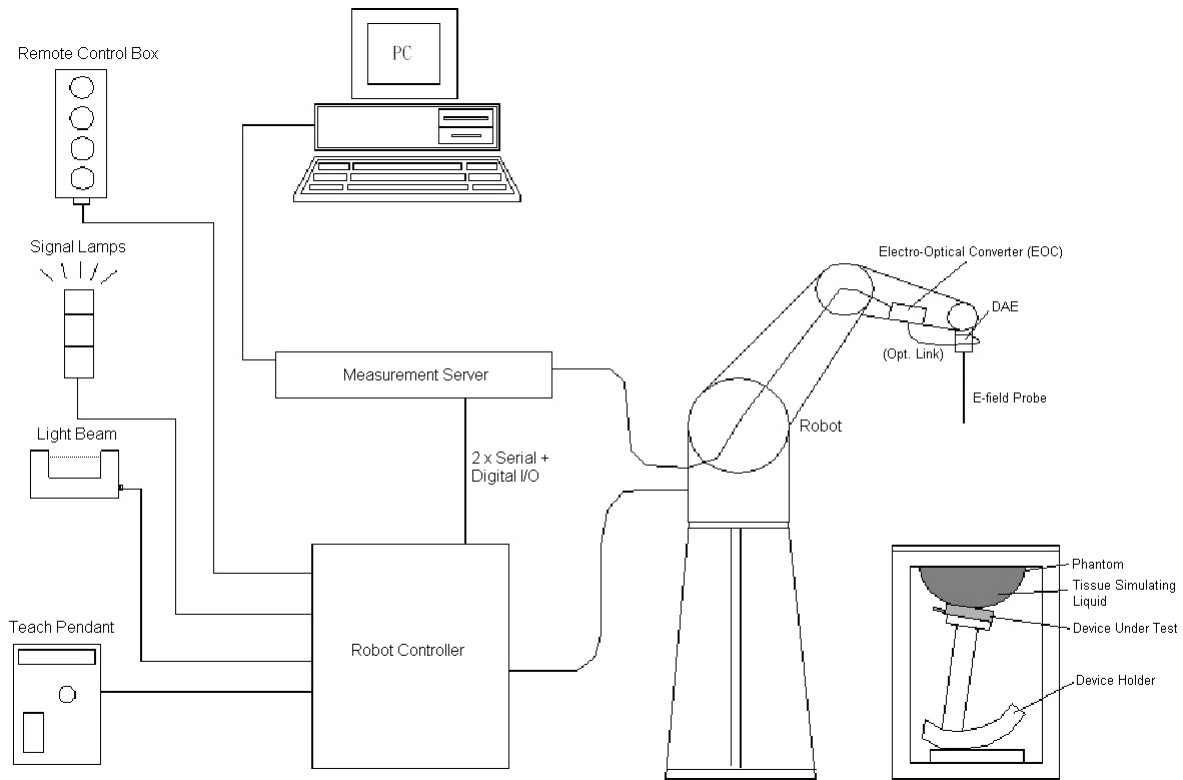

**Fig-3.1 SPEAG DASY52 System Setup**

**3.2.1 Robot**

The DASY52 systems use the high precision robots from Stäubli SA (France). For the 6-axis controller system, the robot controller version of CS8c from Stäubli is used. The Stäubli robot series have many features that are important for our application:

- High precision (repeatability  $\pm 0.035$  mm)
- High reliability (industrial design)
- Jerk-free straight movements
- Low ELF interference (the closed metallic construction shields against motor control fields)





**Fig-3.2 SPEAG DASY52 System**

## FCC SAR Test Report

### 3.2.2 Probes

The SAR measurement is conducted with the dosimetric probe. The probe is specially designed and calibrated for use in liquid with high permittivity. The dosimetric probe has special calibration in liquid at different frequency.

<b>Model</b>	EX3DV4	
<b>Construction</b>	Symmetrical design with triangular core. Built-in shielding against static charges. PEEK enclosure material (resistant to organic solvents, e.g., DGBE).	
<b>Frequency</b>	10 MHz to 6 GHz Linearity: $\pm 0.2$ dB	
<b>Directivity</b>	$\pm 0.3$ dB in HSL (rotation around probe axis) $\pm 0.5$ dB in tissue material (rotation normal to probe axis)	
<b>Dynamic Range</b>	10 $\mu$ W/g to 100 mW/g Linearity: $\pm 0.2$ dB (noise: typically $< 1$ $\mu$ W/g)	
<b>Dimensions</b>	Overall length: 337 mm (Tip: 20 mm) Tip diameter: 2.5 mm (Body: 12 mm) Typical distance from probe tip to dipole centers: 1 mm	

<b>Model</b>	ES3DV3	
<b>Construction</b>	Symmetrical design with triangular core. Interleaved sensors. Built-in shielding against static charges. PEEK enclosure material (resistant to organic solvents, e.g., DGBE).	
<b>Frequency</b>	10 MHz to 4 GHz Linearity: $\pm 0.2$ dB	
<b>Directivity</b>	$\pm 0.2$ dB in HSL (rotation around probe axis) $\pm 0.3$ dB in tissue material (rotation normal to probe axis)	
<b>Dynamic Range</b>	5 $\mu$ W/g to 100 mW/g Linearity: $\pm 0.2$ dB	
<b>Dimensions</b>	Overall length: 337 mm (Tip: 20 mm) Tip diameter: 3.9 mm (Body: 12 mm) Distance from probe tip to dipole centers: 2.0 mm	

<b>Model</b>	ET3DV6	
<b>Construction</b>	Symmetrical design with triangular core Built-in optical fiber for surface detection system. Built-in shielding against static charges. PEEK enclosure material (resistant to organic solvents, e.g., DGBE)	
<b>Frequency</b>	10 MHz to 2.3 GHz; Linearity: $\pm 0.2$ dB	
<b>Directivity</b>	$\pm 0.2$ dB in TSL (rotation around probe axis) $\pm 0.4$ dB in TSL (rotation normal to probe axis)	
<b>Dynamic Range</b>	5 $\mu$ W/g to 100 mW/g; Linearity: $\pm 0.2$ dB	
<b>Dimensions</b>	Overall length: 337 mm (Tip: 16 mm) Tip diameter: 6.8 mm (Body: 12 mm) Distance from probe tip to dipole centers: 2.7 mm	

### 3.2.3 Data Acquisition Electronics (DAE)

<b>Model</b>	DAE3, DAE4	
<b>Construction</b>	Signal amplifier, multiplexer, A/D converter and control logic. Serial optical link for communication with DASY embedded system (fully remote controlled). Two step probe touch detector for mechanical surface detection and emergency robot stop.	
<b>Measurement Range</b>	-100 to +300 mV (16 bit resolution and two range settings: 4mV, 400mV)	
<b>Input Offset Voltage</b>	$< 5\mu$ V (with auto zero)	
<b>Input Bias Current</b>	$< 50$ fA	
<b>Dimensions</b>	60 x 60 x 68 mm	



# FCC SAR Test Report

## 3.2.4 Phantoms

<b>Model</b>	Twin SAM	
<b>Construction</b>	The shell corresponds to the specifications of the Specific Anthropomorphic Mannequin (SAM) phantom defined in IEEE 1528 and IEC 62209-1. It enables the dosimetric evaluation of left and right hand phone usage as well as body mounted usage at the flat phantom region. A cover prevents evaporation of the liquid. Reference markings on the phantom allow the complete setup of all predefined phantom positions and measurement grids by teaching three points with the robot.	
<b>Material</b>	Vinylester, glass fiber reinforced (VE-GF)	
<b>Shell Thickness</b>	2 ± 0.2 mm (6 ± 0.2 mm at ear point)	
<b>Dimensions</b>	Length: 1000 mm Width: 500 mm Height: adjustable feet	
<b>Filling Volume</b>	approx. 25 liters	

<b>Model</b>	ELI	
<b>Construction</b>	Phantom for compliance testing of handheld and body-mounted wireless devices in the frequency range of 30 MHz to 6 GHz. ELI is fully compatible with the IEC 62209-2 standard and all known tissue simulating liquids. ELI has been optimized regarding its performance and can be integrated into our standard phantom tables. A cover prevents evaporation of the liquid. Reference markings on the phantom allow installation of the complete setup, including all predefined phantom positions and measurement grids, by teaching three points. The phantom is compatible with all SPEAG dosimetric probes and dipoles.	
<b>Material</b>	Vinylester, glass fiber reinforced (VE-GF)	
<b>Shell Thickness</b>	2.0 ± 0.2 mm (bottom plate)	
<b>Dimensions</b>	Major axis: 600 mm Minor axis: 400 mm	
<b>Filling Volume</b>	approx. 30 liters	

# FCC SAR Test Report

## 3.2.5 Device Holder

<b>Model</b>	Mounting Device	
<b>Construction</b>	In combination with the Twin SAM Phantom or ELI4, the Mounting Device enables the rotation of the mounted transmitter device in spherical coordinates. Rotation point is the ear opening point. Transmitter devices can be easily and accurately positioned according to IEC, IEEE, FCC or other specifications. The device holder can be locked for positioning at different phantom sections (left head, right head, flat).	
<b>Material</b>	POM	

<b>Model</b>	Laptop Extensions Kit	
<b>Construction</b>	Simple but effective and easy-to-use extension for Mounting Device that facilitates the testing of larger devices according to IEC 62209-2 (e.g., laptops, cameras, etc.). It is lightweight and fits easily on the upper part of the Mounting Device in place of the phone positioner.	
<b>Material</b>	POM, Acrylic glass, Foam	

## 3.2.6 System Validation Dipoles

<b>Model</b>	D-Serial	
<b>Construction</b>	Symmetrical dipole with 1/4 balun. Enables measurement of feed point impedance with NWA. Matched for use near flat phantoms filled with tissue simulating solutions.	
<b>Frequency</b>	750 MHz to 5800 MHz	
<b>Return Loss</b>	> 20 dB	
<b>Power Capability</b>	> 100 W (f < 1GHz), > 40 W (f > 1GHz)	

### 3.2.7 Tissue Simulating Liquids

For SAR measurement of the field distribution inside the phantom, the phantom must be filled with homogeneous tissue simulating liquid to a depth of at least 15 cm. For head SAR testing, the liquid height from the ear reference point (ERP) of the phantom to the liquid top surface is larger than 15 cm. For body SAR testing, the liquid height from the center of the flat phantom to the liquid top surface is larger than 15 cm. The nominal dielectric values of the tissue simulating liquids in the phantom and the tolerance of 5% are listed in Table-3.1.

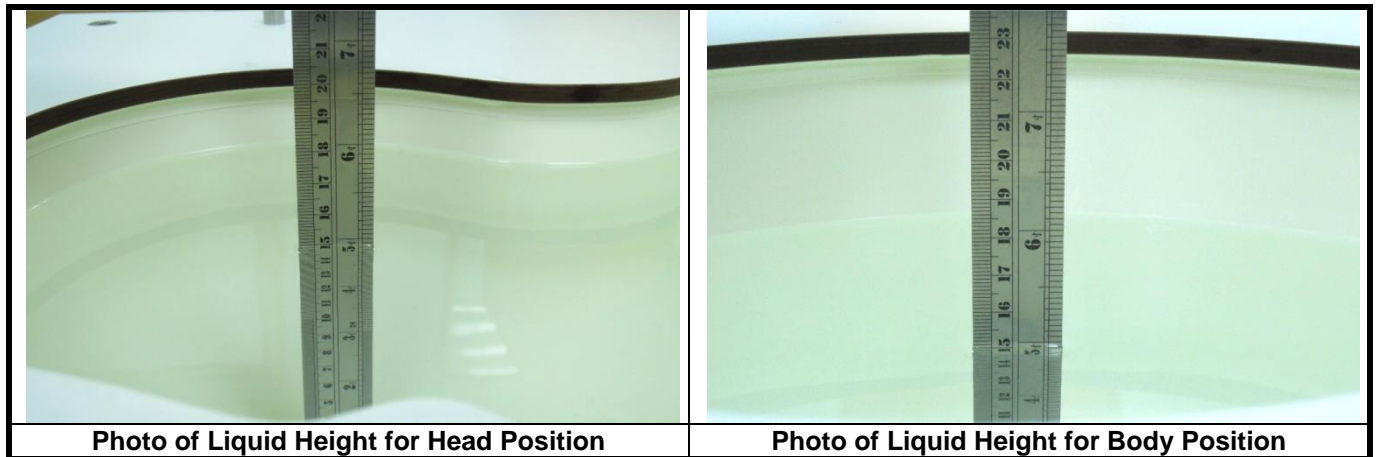

The dielectric properties of the head tissue simulating liquids are defined in IEEE 1528, and KDB 865664 D01 Appendix A. For the body tissue simulating liquids, the dielectric properties are defined in KDB 865664 D01 Appendix A. The dielectric properties of the tissue simulating liquids were verified prior to the SAR evaluation using a dielectric assessment kit and a network analyzer.

**Table-3.1 Targets of Tissue Simulating Liquid**

Frequency (MHz)	Target Permittivity	Range of $\pm 5\%$	Target Conductivity	Range of $\pm 5\%$
<b>For Head</b>				
750	41.9	39.8 ~ 44.0	0.89	0.85 ~ 0.93
835	41.5	39.4 ~ 43.6	0.90	0.86 ~ 0.95
900	41.5	39.4 ~ 43.6	0.97	0.92 ~ 1.02
1450	40.5	38.5 ~ 42.5	1.20	1.14 ~ 1.26
1640	40.3	38.3 ~ 42.3	1.29	1.23 ~ 1.35
1750	40.1	38.1 ~ 42.1	1.37	1.30 ~ 1.44
1800	40.0	38.0 ~ 42.0	1.40	1.33 ~ 1.47
1900	40.0	38.0 ~ 42.0	1.40	1.33 ~ 1.47
2000	40.0	38.0 ~ 42.0	1.40	1.33 ~ 1.47
2300	39.5	37.5 ~ 41.5	1.67	1.59 ~ 1.75
2450	39.2	37.2 ~ 41.2	1.80	1.71 ~ 1.89
2600	39.0	37.1 ~ 41.0	1.96	1.86 ~ 2.06
3500	37.9	36.0 ~ 39.8	2.91	2.76 ~ 3.06
5200	36.0	34.2 ~ 37.8	4.66	4.43 ~ 4.89
5300	35.9	34.1 ~ 37.7	4.76	4.52 ~ 5.00
5500	35.6	33.8 ~ 37.4	4.96	4.71 ~ 5.21
5600	35.5	33.7 ~ 37.3	5.07	4.82 ~ 5.32
5800	35.3	33.5 ~ 37.1	5.27	5.01 ~ 5.53
<b>For Body</b>				
750	55.5	52.7 ~ 58.3	0.96	0.91 ~ 1.01
835	55.2	52.4 ~ 58.0	0.97	0.92 ~ 1.02
900	55.0	52.3 ~ 57.8	1.05	1.00 ~ 1.10
1450	54.0	51.3 ~ 56.7	1.30	1.24 ~ 1.37
1640	53.8	51.1 ~ 56.5	1.40	1.33 ~ 1.47
1750	53.4	50.7 ~ 56.1	1.49	1.42 ~ 1.56
1800	53.3	50.6 ~ 56.0	1.52	1.44 ~ 1.60
1900	53.3	50.6 ~ 56.0	1.52	1.44 ~ 1.60
2000	53.3	50.6 ~ 56.0	1.52	1.44 ~ 1.60
2300	52.9	50.3 ~ 55.5	1.81	1.72 ~ 1.90
2450	52.7	50.1 ~ 55.3	1.95	1.85 ~ 2.05
2600	52.5	49.9 ~ 55.1	2.16	2.05 ~ 2.27
3500	51.3	48.7 ~ 53.9	3.31	3.14 ~ 3.48
5200	49.0	46.6 ~ 51.5	5.30	5.04 ~ 5.57
5300	48.9	46.5 ~ 51.3	5.42	5.15 ~ 5.69
5500	48.6	46.2 ~ 51.0	5.65	5.37 ~ 5.93
5600	48.5	46.1 ~ 50.9	5.77	5.48 ~ 6.06
5800	48.2	45.8 ~ 50.6	6.00	5.70 ~ 6.30

## FCC SAR Test Report

The following table gives the recipes for tissue simulating liquids.

**Table-3.2 Recipes of Tissue Simulating Liquid**

Tissue Type	Bactericide	DGBE	HEC	NaCl	Sucrose	Triton X-100	Water	Diethylene Glycol Mono-hexylether
H750	0.2	-	0.2	1.5	56.0	-	42.1	-
H835	0.2	-	0.2	1.5	57.0	-	41.1	-
H900	0.2	-	0.2	1.4	58.0	-	40.2	-
H1450	-	43.3	-	0.6	-	-	56.1	-
H1640	-	45.8	-	0.5	-	-	53.7	-
H1750	-	47.0	-	0.4	-	-	52.6	-
H1800	-	44.5	-	0.3	-	-	55.2	-
H1900	-	44.5	-	0.2	-	-	55.3	-
H2000	-	44.5	-	0.1	-	-	55.4	-
H2300	-	44.9	-	0.1	-	-	55.0	-
H2450	-	45.0	-	0.1	-	-	54.9	-
H2600	-	45.1	-	0.1	-	-	54.8	-
H3500	-	8.0	-	0.2	-	20.0	71.8	-
H5G	-	-	-	-	-	17.2	65.5	17.3
B750	0.2	-	0.2	0.8	48.8	-	50.0	-
B835	0.2	-	0.2	0.9	48.5	-	50.2	-
B900	0.2	-	0.2	0.9	48.2	-	50.5	-
B1450	-	34.0	-	0.3	-	-	65.7	-
B1640	-	32.5	-	0.3	-	-	67.2	-
B1750	-	31.0	-	0.2	-	-	68.8	-
B1800	-	29.5	-	0.4	-	-	70.1	-
B1900	-	29.5	-	0.3	-	-	70.2	-
B2000	-	30.0	-	0.2	-	-	69.8	-
B2300	-	31.0	-	0.1	-	-	68.9	-
B2450	-	31.4	-	0.1	-	-	68.5	-
B2600	-	31.8	-	0.1	-	-	68.1	-
B3500	-	28.8	-	0.1	-	-	71.1	-
B5G	-	-	-	-	-	10.7	78.6	10.7

### 3.3 SAR System Verification

The system check verifies that the system operates within its specifications. It is performed daily or before every SAR measurement. The system check uses normal SAR measurements in the flat section of the phantom with a matched dipole at a specified distance. The system verification setup is shown as below.

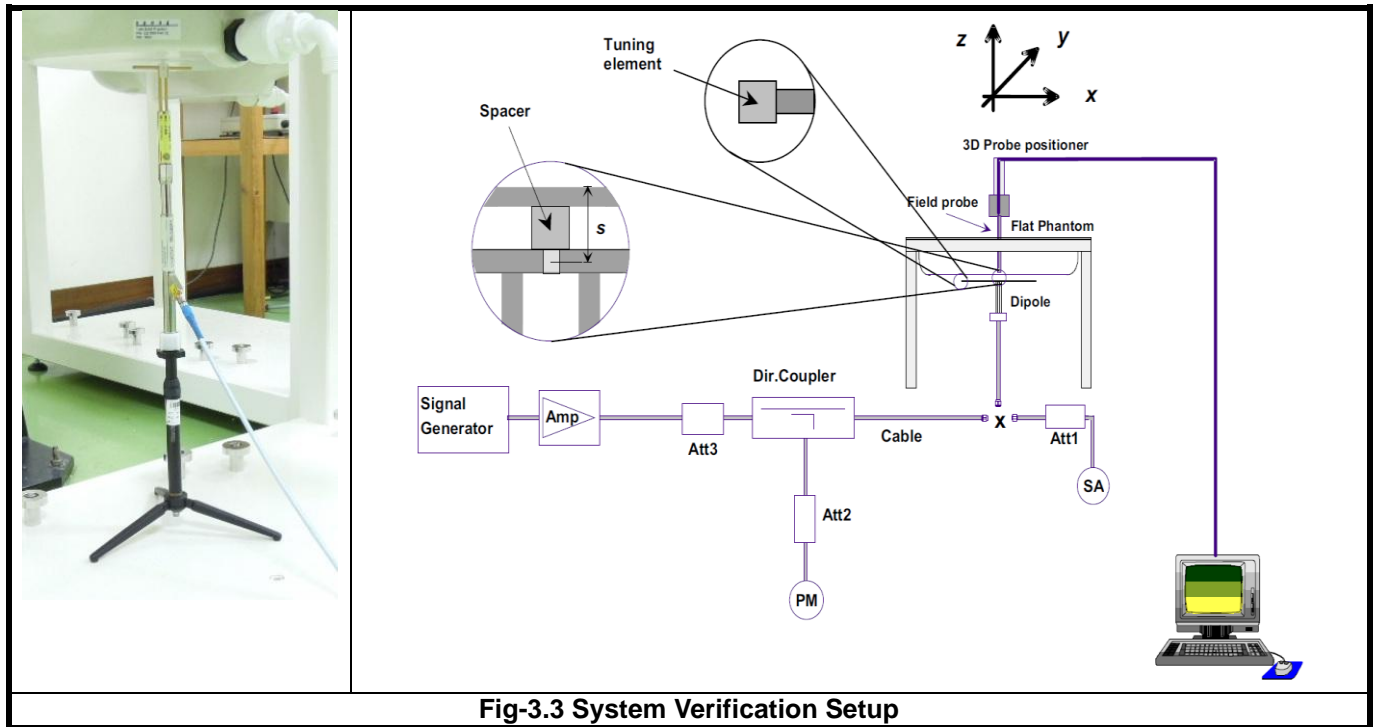

**Fig-3.3 System Verification Setup**

The validation dipole is placed beneath the flat phantom with the specific spacer in place. The distance spacer is touch the phantom surface with a light pressure at the reference marking and be oriented parallel to the long side of the phantom. The spectrum analyzer measures the forward power at the location of the system check dipole connector. The signal generator is adjusted for the desired forward power (250 mW is used for 700 MHz to 3 GHz, 100 mW is used for 3.5 GHz to 6 GHz) at the dipole connector and the power meter is read at that level. After connecting the cable to the dipole, the signal generator is readjusted for the same reading at power meter.

After system check testing, the SAR result will be normalized to 1W forward input power and compared with the reference SAR value derived from validation dipole certificate report. The deviation of system check should be within 10 %.

**3.4 SAR Measurement Procedure**

According to the SAR test standard, the recommended procedure for assessing the peak spatial-average SAR value consists of the following steps:

- (a) Power reference measurement
- (b) Area scan
- (c) Zoom scan
- (d) Power drift measurement

The SAR measurement procedures for each of test conditions are as follows:

- (a) Make EUT to transmit maximum output power
- (b) Measure conducted output power through RF cable
- (c) Place the EUT in the specific position of phantom
- (d) Perform SAR testing steps on the DASY system
- (e) Record the SAR value

**3.4.1 Area & Zoom Scan Procedure**

First Area Scan is used to locate the approximate location(s) of the local peak SAR value(s). The measurement grid within an Area Scan is defined by the grid extent, grid step size and grid offset. Next, in order to determine the EM field distribution in a three-dimensional spatial extension, Zoom Scan is required. The Zoom Scan is performed around the highest E-field value to determine the averaged SAR-distribution over 10 g. According to KDB 865664 D01, the resolution for Area and Zoom scan is specified in the table below.

Items	<= 2 GHz	2-3 GHz	3-4 GHz	4-5 GHz	5-6 GHz
Area Scan ( $\Delta x, \Delta y$ )	<= 15 mm	<= 12 mm	<= 12 mm	<= 10 mm	<= 10 mm
Zoom Scan ( $\Delta x, \Delta y$ )	<= 8 mm	<= 5 mm	<= 5 mm	<= 4 mm	<= 4 mm
Zoom Scan ( $\Delta z$ )	<= 5 mm	<= 5 mm	<= 4 mm	<= 3 mm	<= 2 mm
Zoom Scan Volume	>= 30 mm	>= 30 mm	>= 28 mm	>= 25 mm	>= 22 mm

**Note:**

When zoom scan is required and report SAR is <= 1.4 W/kg, the zoom scan resolution of  $\Delta x / \Delta y$  (2-3GHz: <= 8 mm, 3-4GHz: <= 7 mm, 4-6GHz: <= 5 mm) may be applied.

**3.4.2 Volume Scan Procedure**

The volume scan is used for assess overlapping SAR distributions for antennas transmitting in different frequency bands. It is equivalent to an oversized zoom scan used in standalone measurements. The measurement volume will be used to enclose all the simultaneous transmitting antennas. For antennas transmitting simultaneously in different frequency bands, the volume scan is measured separately in each frequency band. In order to sum correctly to compute the 1g aggregate SAR, the EUT remain in the same test position for all measurements and all volume scan use the same spatial resolution and grid spacing. When all volume scan were completed, the software, SEMCAD postprocessor can combine and subsequently superpose these measurement data to calculating the multiband SAR.

### 3.4.3 Power Drift Monitoring

All SAR testing is under the EUT install full charged battery and transmit maximum output power. In DASY measurement software, the power reference measurement and power drift measurement procedures are used for monitoring the power drift of EUT during SAR test. Both these procedures measure the field at a specified reference position before and after the SAR testing. The software will calculate the field difference in dB. If the power drift more than 5%, the SAR will be retested.

### 3.4.4 Spatial Peak SAR Evaluation

The procedure for spatial peak SAR evaluation has been implemented according to the test standard. It can be conducted for 1g and 10g, as well as for user-specific masses. The DASY software includes all numerical procedures necessary to evaluate the spatial peak SAR value.

The base for the evaluation is a "cube" measurement. The measured volume must include the 1g and 10g cubes with the highest averaged SAR values. For that purpose, the center of the measured volume is aligned to the interpolated peak SAR value of a previously performed area scan.

The entire evaluation of the spatial peak values is performed within the post-processing engine (SEMCAD). The system always gives the maximum values for the 1g and 10g cubes. The algorithm to find the cube with highest averaged SAR is divided into the following stages:

- (a) Extraction of the measured data (grid and values) from the Zoom Scan
- (b) Calculation of the SAR value at every measurement point based on all stored data (A/D values and measurement parameters)
- (c) Generation of a high-resolution mesh within the measured volume
- (d) Interpolation of all measured values from the measurement grid to the high-resolution grid
- (e) Extrapolation of the entire 3-D field distribution to the phantom surface over the distance from sensor to surface
- (f) Calculation of the averaged SAR within masses of 1g and 10g

### 3.4.5 SAR Averaged Methods

In DASY, the interpolation and extrapolation are both based on the modified Quadratic Shepard's method. The interpolation scheme combines a least-square fitted function method and a weighted average method which are the two basic types of computational interpolation and approximation.

Extrapolation routines are used to obtain SAR values between the lowest measurement points and the inner phantom surface. The extrapolation distance is determined by the surface detection distance and the probe sensor offset. The uncertainty increases with the extrapolation distance. To keep the uncertainty within 1% for the 1 g and 10 g cubes, the extrapolation distance should not be larger than 5 mm.



## 4. SAR Measurement Evaluation

### 4.1 EUT Configuration and Setting

#### <Connections between EUT and System Simulator>

For WWAN SAR testing, the EUT was linked and controlled by base station emulator. Communication between the EUT and the emulator was established by air link. The distance between the EUT and the communicating antenna of the emulator is larger than 50 cm and the output power radiated from the emulator antenna is at least 30 dB smaller than the output power of EUT. The EUT was set from the emulator to radiate maximum output power during SAR testing.

#### <Considerations Related to WCDMA for Setup and Testing>

##### Release 5 HSDPA Data Devices

The 3G SAR test reduction procedure is applied to body SAR with 12.2 kbps RMC as the primary mode. Otherwise, body SAR for HSDPA is measured using an FRC with H-Set 1 in Sub-test 1 and a 12.2 kbps RMC configured in Test Loop Mode 1, for the highest reported SAR configuration in 12.2 kbps RMC without HSDPA. HSDPA is configured according to the applicable UE category of a test device. The number of HS-DSCH / HS-PDSCHs, HARQ processes, minimum inter-TTI interval, transport block sizes and RV coding sequence are defined by the H-set. To maintain a consistent test configuration and stable transmission conditions, QPSK is used in the H-set for SAR testing. HS-DPCCH should be configured with a CQI feedback cycle of 4 ms and a CQI repetition factor of 2 to maintain a constant rate of active CQI slots. DPCCH and DPDCH gain factors ( $\beta_c$ ,  $\beta_d$ ), and HS-DPCCH power offset parameters ( $\Delta_{ACK}$ ,  $\Delta_{NACK}$ ,  $\Delta_{CQI}$ ) are set according to values indicated in below. The CQI value is determined by the UE category, transport block size, number of HS-PDSCHs and modulation used in the H-set.

Sub-test	$\beta_c$	$\beta_d$	$\beta_d$ (SF)	$\beta_d/\beta_c$	$\beta_{HS}^{(1)(2)}$	CM <sup>(3)</sup> (dB)	MPR <sup>(3)</sup> (dB)
1	2/15	15/15	64	2/15	4/15	0.0	0.0
2	12/15 <sup>(4)</sup>	15/15 <sup>(4)</sup>	64	12/15 <sup>(4)</sup>	24/15	1.0	0.0
3	15/15	8/15	64	15/8	30/15	1.5	0.5
4	15/15	4/15	64	15/4	30/15	1.5	0.5

Note 1:  $\Delta_{ACK}$ ,  $\Delta_{NACK}$  and  $\Delta_{CQI} = 30/15$  with  $\beta_{HS} = 30/15 * \beta_c$ .  
 Note 2: For the HS-DPCCH power mask requirement test in clause 5.2C, 5.7A, and the Error Vector Magnitude (EVM) with HS-DPCCH test in clause 5.13.1A, and HSDPA EVM with phase discontinuity in clause 5.13.1AA,  $\Delta_{ACK}$  and  $\Delta_{NACK} = 30/15$  with  $\beta_{HS} = 30/15 * \beta_c$ , and  $\Delta_{CQI} = 24/15$  with  $\beta_{HS} = 24/15 * \beta_c$ .  
 Note 3: CM = 1 for  $\beta_d/\beta_c = 12/15$ ,  $\beta_{HS}/\beta_c = 24/15$ . For all other combinations of DPDCH, DPCCH and HS-DPCCH the MPR is based on the relative CM difference. This is applicable for only UEs that support HSDPA in release 6 and later releases.  
 Note 4: For subtest 2 the  $\beta_d/\beta_c$  ratio of 12/15 for the TFC during the measurement period (TF1, TF0) is achieved by setting the signalled gain factors for the reference TFC (TF1, TF0) to  $\beta_c = 11/15$  and  $\beta_d = 15/15$ .

# FCC SAR Test Report

## Release 6 HSUPA Data Devices

The 3G SAR test reduction procedure is applied to body SAR with 12.2 kbps RMC as the primary mode. Otherwise, body SAR for HSPA is measured with E-DCH Sub-test 5, using H-Set 1 and QPSK for FRC and a 12.2 kbps RMC configured in Test Loop Mode 1 and power control algorithm 2, according to the highest reported body SAR configuration in 12.2 kbps RMC without HSPA. When VOIP applies to head exposure, the 3G SAR test reduction procedure is applied with 12.2 kbps RMC as the primary mode. Otherwise, the same HSPA configuration used for body SAR measurements are applied to head exposure testing. Due to inner loop power control requirements in HSPA, a communication test set is required for output power and SAR tests. The 12.2 kbps RMC, FRC H-set 1 and E-DCH configurations for HSPA are configured according to the  $\beta$  values indicated in below.

Sub-test	$\beta_c$	$\beta_d$	$\beta_d$ (SF)	$\beta_c / \beta_d$	$\beta_{HS}^{(1)}$	$\beta_{ec}$	$\beta_{ed}^{(4)(5)}$	$\beta_{ed}$ (SF)	$\beta_{ed}$ (Codes)	CM <sup>(2)</sup> (dB)	MPR <sup>(2)(6)</sup> (dB)	AG <sup>(5)</sup> Index	E-TFCI
1	11/15 <sup>(3)</sup>	15/15 <sup>(3)</sup>	64	11/15 <sup>(3)</sup>	22/15	209/225	1309/225	4	1	1.0	0.0	20	75
2	6/15	15/15	64	6/15	12/15	12/15	94/75	4	1	3.0	2.0	12	67
3	15/15	9/15	64	15/9	30/15	30/15	$\beta_{ed1}: 47/15$ $\beta_{ed2}: 47/15$	4 4	2	2.0	1.0	15	92
4	2/15	15/15	64	2/15	4/15	2/15	56/75	4	1	3.0	2.0	17	71
5	15/15	0	-	-	5/15	5/15	47/15	4	1	1.0	0.0	12	67

Note 1: For sub-test 1 to 4,  $\Delta_{ACK}$ ,  $\Delta_{NACK}$  and  $\Delta_{CQI} = 30/15$  with  $\beta_{HS} = 30/15 * \beta_c$ . For sub-test 5,  $\Delta_{ACK}$ ,  $\Delta_{NACK}$  and  $\Delta_{CQI} = 5/15$  with  $\beta_{HS} = 5/15 * \beta_c$ .  
 Note 2: CM = 1 for  $\beta_c/\beta_d = 12/15$ ,  $\beta_{HS}/\beta_c = 24/15$ . For all other combinations of DPDCH, DPCCH, HS-DPCCH, E-DPDCH and E-DPCCH the MPR is based on the relative CM difference.  
 Note 3: For subtest 1 the  $\beta_c/\beta_d$  ratio of 11/15 for the TFC during the measurement period (TF1, TF0) is achieved by setting the signalled gain factors for the reference TFC (TF1, TF1) to  $\beta_c = 10/15$  and  $\beta_d = 15/15$ .  
 Note 4: In case of testing by UE using E-DPDCH Physical Layer category 1, Sub-test 3 is omitted according to TS25.306 Table 5.1g.  
 Note 5:  $\beta_{ed}$  can not be set directly; it is set by Absolute Grant Value.  
 Note 6: For subtests 2, 3 and 4, UE may perform E-DPDCH power scaling at max power which could results in slightly smaller MPR values.

## <Considerations Related to LTE for Setup and Testing>

This device contains LTE transmitter which follows 3GPP standards, is category 3, supports both QPSK and 16QAM modulations, and supported LTE band and channel bandwidth is listed in below. The output power was tested per 3GPP TS 36.521-1 maximum transmit procedures for both QPSK and 16QAM modulation. The results please refer to section 4.6 of this report.

EUT Supported LTE Band and Channel Bandwidth						
LTE Band	BW 1.4 MHz	BW 3 MHz	BW 5 MHz	BW 10 MHz	BW 15 MHz	BW 20 MHz
2	V	V	V	V	V	V
4	V	V	V	V	V	V
5	V	V	V	V		
7			V	V	V	V
12	V	V	V	V		
13			V	V		
14			V	V		
25	V	V	V	V	V	V
26	V	V	V	V	V	
30			V	V		
41			V	V	V	V

The LTE maximum power reduction (MPR) in accordance with 3GPP TS 36.101 is active all times during LTE operation. The allowed MPR for the maximum output power is specified in below.

Modulation	Channel Bandwidth / RB Configurations						LTE MPR Setting (dB)
	BW 1.4 MHz	BW 3 MHz	BW 5 MHz	BW 10 MHz	BW 15 MHz	BW 20 MHz	
QPSK	> 5	> 4	> 8	> 12	> 16	> 18	1
16QAM	<= 5	<= 4	<= 8	<= 12	<= 16	<= 18	1
16QAM	> 5	> 4	> 8	> 12	> 16	> 18	2

**Note:** MPR is according to the standard and implemented in the circuit (mandatory).

In addition, the device is compliant with additional maximum power reduction (A-MPR) requirements defined in 3GPP TS 36.101 section 6.2.4 that was disabled for all FCC compliance testing.

During LTE SAR testing, the related parameters of operating band, channel bandwidth, uplink channel number, modulation type, and RB was set in base station simulator. When the EUT has registered and communicated to base station simulator, the simulator set to make EUT transmitting the maximum radiated power.

## TDD-LTE Setup Configurations

According to KDB 941225 D05, SAR testing for TDD-LTE device must be tested using a fixed periodic duty factor according to the highest transmission duty factor implemented for the device and supported by the defined 3GPP TDD-LTE configurations. The TDD-LTE of this device supports frame structure type 2 defined in 3GPP TS 36.211 section 4.2, and the frame structure configuration can be referred to below.

# FCC SAR Test Report

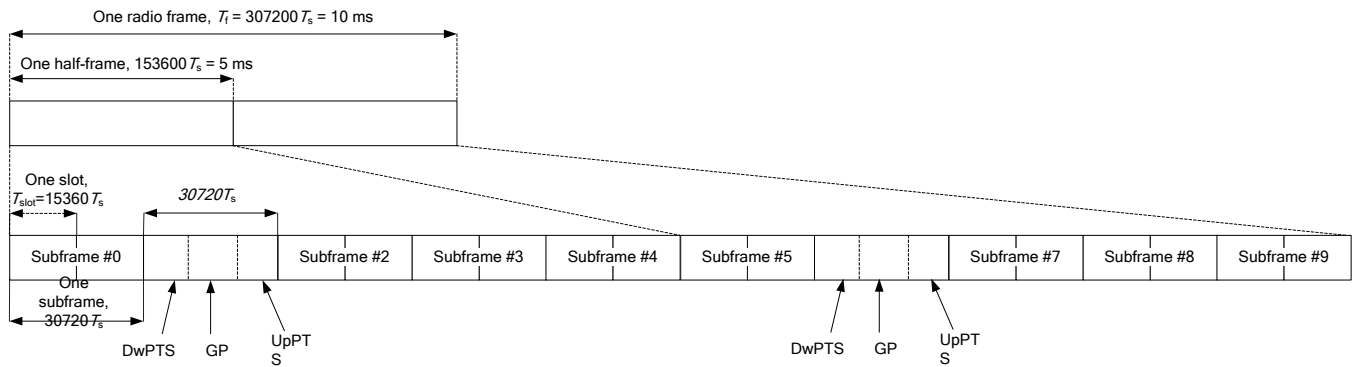

3GPP TS 36.211 Figure 4.2-1: Frame Structure Type 2

Special Subframe Configuration	Normal Cyclic Prefix in Downlink			Extended Cyclic Prefix in Downlink		
	DwPTS	UpPTS		DwPTS	UpPTS	
		Normal Cyclic Prefix in Uplink	Extended Cyclic Prefix in Uplink		Normal Cyclic Prefix in Uplink	Extended Cyclic Prefix in Uplink
0	6592 · Ts	2192 · Ts	2560 · Ts	7680 · Ts	2192 · Ts	2560 · Ts
1	19760 · Ts			20480 · Ts		
2	21952 · Ts			23040 · Ts		
3	24144 · Ts			25600 · Ts		
4	26336 · Ts			7680 · Ts		
5	6592 · Ts	4384 · Ts	5120 · Ts	20480 · Ts	4384 · Ts	5120 · Ts
6	19760 · Ts			23040 · Ts		
7	21952 · Ts			12800 · Ts		
8	24144 · Ts			-		
9	13168 · Ts	-	-	-	-	-

3GPP TS 36.211 Table 4.2-1: Configuration of Special Subframe

Uplink-Downlink Configuration	Downlink-to-Uplink Switch-Point Periodicity	Subframe Number										
		0	1	2	3	4	5	6	7	8	9	
0	5 ms	D	S	U	U	U	D	S	U	U	U	
1	5 ms	D	S	U	U	D	D	S	U	U	D	
2	5 ms	D	S	U	D	D	D	S	U	D	D	
3	10 ms	D	S	U	U	U	D	D	D	D	D	
4	10 ms	D	S	U	U	D	D	D	D	D	D	
5	10 ms	D	S	U	D	D	D	D	D	D	D	
6	5 ms	D	S	U	U	U	D	S	U	U	D	

3GPP TS 36.211 Table 4.2-2: Uplink-Downlink Configurations

The variety of different TD-LTE uplink-downlink configurations allows a network operator to allocate the network's capacity between uplink and downlink traffic to meet the needs of the network. The uplink duty cycle of these seven configurations can readily be computed and shown in below.

UL-DL Configuration	0	1	2	3	4	5	6
Highest Duty-Cycle	63.33%	43.33%	23.33%	31.67%	21.67%	11.67%	53.33%

### <Considerations Related to WLAN for Setup and Testing>

In general, various vendor specific external test software and chipset based internal test modes are typically used for SAR measurement. These chipset based test mode utilities are generally hardware and manufacturer dependent, and often include substantial flexibility to reconfigure or reprogram a device. A Wi-Fi device must be configured to transmit continuously at the required data rate, channel bandwidth and signal modulation, using the highest transmission duty factor supported by the test mode tools for SAR measurement. The test frequencies established using test mode must correspond to the actual channel frequencies. When 802.11 frame gaps are accounted for in the transmission, a maximum transmission duty factor of 92 - 96% is typically achievable in most test mode configurations. A minimum transmission duty factor of 85% is required to avoid certain hardware and device implementation issues related to wide range SAR scaling. In addition, a periodic transmission duty factor is required for current generation SAR systems to measure SAR correctly. The reported SAR must be scaled to 100% transmission duty factor to determine compliance at the maximum tune-up tolerance limit.

According to KDB 248227 D01, this device has installed WLAN engineering testing software which can provide continuous transmitting RF signal. During WLAN SAR testing, this device was operated to transmit continuously at the maximum transmission duty with specified transmission mode, operating frequency, lowest data rate, and maximum output power.

### Initial Test Configuration

An initial test configuration is determined for OFDM transmission modes in 2.4 GHz and 5 GHz bands according to the channel bandwidth, modulation and data rate combination(s) with the highest maximum output power specified for production units in each standalone and aggregated frequency band. When the same maximum power is specified for multiple transmission modes in a frequency band, the largest channel bandwidth, lowest order modulation, lowest data rate and lowest order 802.11a/g/n/ac mode is used for SAR measurement, on the highest measured output power channel in the initial test configuration, for each frequency band.

### Subsequent Test Configuration

SAR measurement requirements for the remaining 802.11 transmission mode configurations that have not been tested in the initial test configuration are determined separately for each standalone and aggregated frequency band, in each exposure condition, according to the maximum output power specified for production units. Additional power measurements may be required to determine if SAR measurements are required for subsequent highest output power channels in a subsequent test configuration. When the highest reported SAR for the initial test configuration according to the initial test position or fixed exposure position requirements, is adjusted by the ratio of the subsequent test configuration to initial test configuration specified maximum output power and the adjusted SAR is  $\leq 1.2$  W/kg, SAR is not required for that subsequent test configuration.

### **SAR Test Configuration and Channel Selection**

When multiple channel bandwidth configurations in a frequency band have the same specified maximum output power, the initial test configuration is using largest channel bandwidth, lowest order modulation, lowest data rate, and lowest order 802.11 mode (i.e., 802.11a is chosen over 802.11n then 802.11ac or 802.11g is chosen over 802.11n). After an initial test configuration is determined, if multiple test channels have the same measured maximum output power, the channel chosen for SAR measurement is determined according to the following.

- 1) The channel closest to mid-band frequency is selected for SAR measurement.
- 2) For channels with equal separation from mid-band frequency; for example, high and low channels or two mid-band channels, the higher frequency (number) channel is selected for SAR measurement.

### **Test Reduction for U-NII-1 (5.2 GHz) and U-NII-2A (5.3 GHz) Bands**

For devices that operate in both U-NII bands using the same transmitter and antenna(s), SAR test reduction is determined according to the following.

- 1) When the same maximum output power is specified for both bands, begin SAR measurement in U-NII-2A band by applying the OFDM SAR requirements. If the highest reported SAR for a test configuration is  $\leq 1.2$  W/kg, SAR is not required for U-NII-1 band for that configuration (802.11 mode and exposure condition).
- 2) When different maximum output power is specified for the bands, begin SAR measurement in the band with higher specified maximum output power. The highest reported SAR for the tested configuration is adjusted by the ratio of lower to higher specified maximum output power for the two bands. When the adjusted SAR is  $\leq 1.2$  W/kg, SAR is not required for the band with lower maximum output power in that test configuration.

### **<Considerations Related to Bluetooth for Setup and Testing>**

This device has installed Bluetooth engineering testing software which can provide continuous transmitting RF signal. During Bluetooth SAR testing, this device was operated to transmit continuously at the maximum transmission duty with specified transmission mode, operating frequency, lowest data rate, and maximum output power.

## **4.2 EUT Testing Position**

This hand-held device was test on the extremity exposure conditions. Extremity SAR was tested on the Rear Face, Top Side, and Left Side positions for WWAN antenna, and Rear Face, Top Side, and Right Side positions for WLAN antenna. In these positions, the separation distance between EUT and phantom is 0 cm.

### **4.2.1 SAR Test Exclusion Evaluations**

This device is designed to operate in the hands. It cannot be supported by body and has no body-worn accessory. Considering above, the hand-held device applied to population/uncontrolled extremity exposure condition. According to KDB 447498 D01, the SAR test exclusion was evaluated based on the shortest separation distance between each antenna and surfaces listed in below.

# FCC SAR Test Report

Tx Antenna	Tx Interface	Frequency (MHz)	Test Position	Minimum Separation Distance (mm)	Maximum Output Power		Calculated Threshold Value	Extremity 10g-SAR Test Require?	
					(dBm)	(mW)			
Cellular	WCDMA II	1907.6	Top Side	23.5	24.0	251.19	14.75 (> 7.5)	YES	
			Bottom Side	178.7			1558 (> Power)	No	
			Left Side	4.2			82.54 (> 7.5)	YES	
			Right Side	185.2			1623 (> Power)	No	
	WCDMA IV	1752.6	1752.6	Rear Face	18.7	24.0	251.19	18.54 (> 7.5)	YES
				Top Side	23.5			14.14 (> 7.5)	YES
				Bottom Side	178.7			1570 (> Power)	No
				Left Side	4.2			79.12 (> 7.5)	YES
	WCDMA V	846.6	846.6	Right Side	185.2	24.0	251.19	1635 (> Power)	No
				Rear Face	18.7			17.77 (> 7.5)	YES
				Top Side	23.5			9.83 (> 7.5)	YES
				Bottom Side	178.7			1133 (> Power)	No
	LTE 2	1909.3	1909.3	Left Side	4.2	24.0	251.19	54.99 (> 7.5)	YES
				Right Side	185.2			1170 (> Power)	No
				Rear Face	18.7			12.35 (> 7.5)	YES
				Top Side	23.5			14.76 (> 7.5)	YES
	LTE 4	1754.3	1754.3	Bottom Side	178.7	24.0	251.19	1558 (> Power)	No
				Left Side	4.2			82.58 (> 7.5)	YES
				Right Side	185.2			1623 (> Power)	No
				Rear Face	18.7			18.55 (> 7.5)	YES
	LTE 5	848.3	848.3	Top Side	23.5	24.0	251.19	14.15 (> 7.5)	YES
				Bottom Side	178.7			1570 (> Power)	No
				Left Side	4.2			79.15 (> 7.5)	YES
				Right Side	185.2			1635 (> Power)	No
	LTE 7	2567.5	2567.5	Rear Face	18.7	23.0	199.53	17.78 (> 7.5)	YES
				Top Side	23.5			9.84 (> 7.5)	YES
				Bottom Side	178.7			1134 (> Power)	No
				Left Side	4.2			55.04 (> 7.5)	YES
	LTE 12	715.3	715.3	Right Side	185.2	24.0	251.19	1171 (> Power)	No
				Rear Face	18.7			12.36 (> 7.5)	YES
				Top Side	23.5			13.64 (> 7.5)	YES
				Bottom Side	178.7			1521 (> Power)	No
	LTE 13	784.5	784.5	Left Side	4.2	24.0	251.19	76.3 (> 7.5)	YES
				Right Side	185.2			1586 (> Power)	No
				Rear Face	18.7			17.14 (> 7.5)	YES
				Top Side	23.5			9.03 (> 7.5)	YES
	LTE 25	1914.3	1914.3	Bottom Side	178.7	24.0	251.19	1057 (> Power)	No
				Left Side	4.2			50.54 (> 7.5)	YES
				Right Side	185.2			1088 (> Power)	No
				Rear Face	18.7			11.35 (> 7.5)	YES
	LTE 26	848.3	848.3	Top Side	23.5	24.0	251.19	9.46 (> 7.5)	YES
				Bottom Side	178.7			1096 (> Power)	No
				Left Side	4.2			52.93 (> 7.5)	YES
				Right Side	185.2			1130 (> Power)	No
	LTE 30	2312.5	2312.5	Rear Face	18.7	23.0	199.53	11.89 (> 7.5)	YES
				Top Side	23.5			14.78 (> 7.5)	YES
				Bottom Side	178.7			1558 (> Power)	No
				Left Side	4.2			82.69 (> 7.5)	YES
LTE 41	2687.5	2687.5	Right Side	185.2	23.0	199.53	1623 (> Power)	No	
			Rear Face	18.7			18.57 (> 7.5)	YES	
			Top Side	23.5			9.84 (> 7.5)	YES	
			Bottom Side	178.7			1134 (> Power)	No	
LTE 41	2687.5	2687.5	Left Side	4.2	23.0	199.53	55.04 (> 7.5)	YES	
			Right Side	185.2			1171 (> Power)	No	
			Rear Face	18.7			12.36 (> 7.5)	YES	
			Top Side	23.5			12.94 (> 7.5)	YES	
LTE 41	2687.5	2687.5	Bottom Side	178.7	23.0	199.53	1533 (> Power)	No	
			Left Side	4.2			72.41 (> 7.5)	YES	
			Right Side	185.2			1598 (> Power)	No	
			Rear Face	18.7			16.26 (> 7.5)	YES	
LTE 41	2687.5	2687.5	Top Side	23.5	23.0	199.53	13.95 (> 7.5)	YES	
			Bottom Side	178.7			1515 (> Power)	No	
			Left Side	4.2			78.06 (> 7.5)	YES	
			Right Side	185.2			1580 (> Power)	No	
LTE 41	2687.5	2687.5	Rear Face	18.7	23.0	199.53	17.53 (> 7.5)	YES	



# FCC SAR Test Report

<QCNA364A>

Tx Antenna	Tx Interface	Frequency (MHz)	Test Position	Minimum Separation Distance (mm)	Maximum Output Power		Calculated Threshold Value	Extremity 10g-SAR Test Require?
					(dBm)	(mW)		
WLAN 0	WLAN 2.4G	2462	Top Side	23.5	20.5	112.2	7.48 (< 7.5)	No
			Bottom Side	176.6			1504 (> Power)	No
			Left Side	191.68			1655 (> Power)	No
			Right Side	4.2			41.84 (> 7.5)	YES
			Rear Face	18.7			9.4 (> 7.5)	YES
	WLAN 5.2G	5240	Top Side	23.5	15.0	31.62	3.12 (< 7.5)	No
			Bottom Side	176.6			1429 (> Power)	No
			Left Side	191.68			1580 (> Power)	No
			Right Side	4.2			17.44 (> 7.5)	YES
	WLAN 5.3G	5320	Top Side	23.5	19.0	79.43	3.92 (< 7.5)	No
			Bottom Side	176.6			7.75 (> 7.5)	YES
			Left Side	191.68			1428 (> Power)	No
			Right Side	4.2			1579 (> Power)	No
	WLAN 5.6G	5700	Top Side	23.5	19.0	79.43	43.38 (> 7.5)	YES
			Bottom Side	176.6			9.74 (> 7.5)	YES
			Left Side	191.68			8.03 (> 7.5)	YES
			Right Side	4.2			1423 (> Power)	No
	WLAN 5.8G	5825	Top Side	23.5	19.0	79.43	1573 (> Power)	No
			Bottom Side	176.6			44.91 (> 7.5)	YES
			Left Side	191.68			10.09 (> 7.5)	YES
Right Side			4.2	8.11 (> 7.5)			YES	
WLAN 1	WLAN 2.4G	2462	Top Side	123.6	20.5	112.2	1421 (> Power)	No
			Bottom Side	165.3			1572 (> Power)	No
			Left Side	157.9			45.4 (> 7.5)	YES
			Right Side	34.2			10.2 (> 7.5)	YES
			Rear Face	17.7			974 (> Power)	No
	WLAN 5.2G	5240	Top Side	123.6	15.0	31.62	1391 (> Power)	No
			Bottom Side	165.3			1317 (> Power)	No
			Left Side	157.9			5.14 (< 7.5)	No
			Right Side	34.2			9.93 (> 7.5)	YES
	WLAN 5.3G	5320	Top Side	123.6	19.0	79.43	899 (> Power)	No
			Bottom Side	165.3			1316 (> Power)	No
			Left Side	157.9			1242 (> Power)	No
			Right Side	34.2			2.14 (< 7.5)	No
	WLAN 5.6G	5700	Top Side	123.6	19.0	79.43	4.14 (< 7.5)	No
			Bottom Side	165.3			898 (> Power)	No
			Left Side	157.9			1315 (> Power)	No
			Right Side	34.2			1241 (> Power)	No
	WLAN 5.8G	5825	Top Side	123.6	19.0	79.43	5.33 (< 7.5)	No
			Bottom Side	165.3			10.29 (> 7.5)	YES
			Left Side	157.9			893 (> Power)	No
Right Side			34.2	1310 (> Power)			No	
Bluetooth	2480	Top Side	123.6	7.0	5.01	1236 (> Power)	No	
		Bottom Side	165.3			5.51 (< 7.5)	No	
		Left Side	157.9			10.66 (> 7.5)	YES	
		Right Side	34.2			891 (> Power)	No	
		Rear Face	17.7			1308 (> Power)	No	

# FCC SAR Test Report

Tx Antenna	Tx Interface	Frequency (MHz)	Test Position	Minimum Separation Distance (mm)	Maximum Output Power		Calculated Threshold Value	Extremity 10g-SAR Test Require?	
					(dBm)	(mW)			
WLAN 0+1	WLAN 2.4G	2462	Top Side	23.5	23.5	223.87	14.96 (> 7.5)	YES	
			Bottom Side	176.6			1504 (> Power)	No	
			Left Side	191.68			1655 (> Power)	No	
			Right Side	4.2			83.68 (> 7.5)	YES	
	WLAN 5.2G	5240	5320	Rear Face	18.7	18	63.1	18.8 (> 7.5)	YES
				Top Side	23.5			6.14 (< 7.5)	No
				Bottom Side	176.6			1429 (> Power)	No
				Left Side	191.68			1580 (> Power)	No
	WLAN 5.3G	5320	5700	Right Side	4.2	22.0	158.49	34.34 (> 7.5)	YES
				Rear Face	18.7			7.71 (> 7.5)	YES
				Top Side	23.5			15.51 (> 7.5)	YES
				Bottom Side	176.6			1428 (> Power)	No
	WLAN 5.6G	5700	5825	Left Side	191.68	22.0	158.49	1579 (> Power)	No
				Right Side	4.2			86.77 (> 7.5)	YES
				Rear Face	18.7			19.49 (> 7.5)	YES
				Top Side	23.5			16.05 (> 7.5)	YES
	WLAN 5.8G	5825	5825	Bottom Side	176.6	22.0	158.49	1423 (> Power)	No
				Left Side	191.68			1573 (> Power)	No
				Right Side	4.2			89.81 (> 7.5)	YES
				Rear Face	18.7			20.17 (> 7.5)	YES
WLAN 5.8G	5825	5825	Top Side	23.5	22.0	158.49	16.23 (> 7.5)	YES	
			Bottom Side	176.6			1421 (> Power)	No	
			Left Side	191.68			1572 (> Power)	No	
			Right Side	4.2			90.79 (> 7.5)	YES	
WLAN 5.8G	5825	5825	Rear Face	18.7	22.0	158.49	20.39 (> 7.5)	YES	

Note: When the separation distance is  $\leq 50$  mm, the SAR test is not required for the calculated threshold value  $\leq 7.5$ . When the separation distance is  $> 50$  mm, the SAR test is not required for the calculated threshold power  $>$  maximum output power.

# FCC SAR Test Report

## 4.3 Tissue Verification

The measuring results for tissue simulating liquid are shown as below.

Test Date	Tissue Type	Frequency (MHz)	Liquid Temp. (°C)	Measured Conductivity (σ)	Measured Permittivity (ε <sub>r</sub> )	Target Conductivity (σ)	Target Permittivity (ε <sub>r</sub> )	Conductivity Deviation (%)	Permittivity Deviation (%)
Oct. 28, 2017	Extremity	750	23.2	0.959	56.412	0.96	55.5	-0.10	1.64
Oct. 28, 2017	Extremity	835	23.3	1.017	57.276	0.97	55.2	4.85	3.76
Oct. 28, 2017	Extremity	1750	23.3	1.435	52.026	1.49	53.4	-3.69	-2.57
Oct. 28, 2017	Extremity	1900	23.2	1.584	51.609	1.52	53.3	4.21	-3.17
Oct. 28, 2017	Extremity	2300	23.1	1.854	51.508	1.81	52.9	2.43	-2.63
Oct. 28, 2017	Extremity	2600	23.2	2.188	50.649	2.16	52.5	1.30	-3.53

### <QCNA364A>

Test Date	Tissue Type	Frequency (MHz)	Liquid Temp. (°C)	Measured Conductivity (σ)	Measured Permittivity (ε <sub>r</sub> )	Target Conductivity (σ)	Target Permittivity (ε <sub>r</sub> )	Conductivity Deviation (%)	Permittivity Deviation (%)
Oct. 20, 2017	Extremity	2450	23.3	1.969	51.420	1.95	52.7	0.97	-2.43
Oct. 28, 2017	Extremity	2450	23.3	2.016	51.637	1.95	52.7	3.38	-2.02
Oct. 28, 2017	Extremity	5250	23.4	5.381	49.124	5.36	48.9	0.39	0.46
Oct. 28, 2017	Extremity	5600	23.4	5.884	48.452	5.77	48.5	1.98	-0.10
Oct. 28, 2017	Extremity	5800	23.4	6.141	47.955	6.00	48.2	2.35	-0.51

#### Note:

The dielectric properties of the tissue simulating liquid must be measured within 24 hours before the SAR testing and within ±5% of the target values. Liquid temperature during the SAR testing must be within ±2 °C.

## 4.4 System Validation

The SAR measurement system was validated according to procedures in KDB 865664 D01. The validation status in tabulated summary is as below.

Test Date	Probe S/N	Calibration Point		Measured Conductivity (σ)	Measured Permittivity (ε <sub>r</sub> )	Validation for CW			Validation for Modulation		
						Sensitivity Range	Probe Linearity	Probe Isotropy	Modulation Type	Duty Factor	PAR
Oct. 28, 2017	3971	Extremity	750	0.959	56.412	Pass	Pass	Pass	N/A	N/A	N/A
Oct. 28, 2017	3971	Extremity	835	1.017	57.276	Pass	Pass	Pass	N/A	N/A	N/A
Oct. 28, 2017	3971	Extremity	1750	1.435	52.026	Pass	Pass	Pass	N/A	N/A	N/A
Oct. 28, 2017	3971	Extremity	1900	1.584	51.609	Pass	Pass	Pass	N/A	N/A	N/A
Oct. 28, 2017	3971	Extremity	2300	1.854	51.508	Pass	Pass	Pass	N/A	N/A	N/A
Oct. 28, 2017	3971	Extremity	2600	2.188	50.649	Pass	Pass	Pass	N/A	N/A	N/A

### <QCNA364A>

Test Date	Probe S/N	Calibration Point		Measured Conductivity (σ)	Measured Permittivity (ε <sub>r</sub> )	Validation for CW			Validation for Modulation		
						Sensitivity Range	Probe Linearity	Probe Isotropy	Modulation Type	Duty Factor	PAR
Oct. 20, 2017	3971	Extremity	2450	1.969	51.420	Pass	Pass	Pass	N/A	N/A	N/A
Oct. 28, 2017	7375	Extremity	2450	2.016	51.637	Pass	Pass	Pass	OFDM	N/A	Pass
Oct. 19, 2017	7375	Extremity	5250	5.381	49.124	Pass	Pass	Pass	OFDM	N/A	Pass
Oct. 19, 2017	7375	Extremity	5600	5.884	48.452	Pass	Pass	Pass	OFDM	N/A	Pass
Oct. 19, 2017	7375	Extremity	5800	6.141	47.955	Pass	Pass	Pass	OFDM	N/A	Pass

**4.5 System Verification**

The measuring result for system verification is tabulated as below.

Test Date	Mode	Frequency (MHz)	1W Target SAR-10g (W/kg)	Measured SAR-10g (W/kg)	Normalized to 1W SAR-10g (W/kg)	Deviation (%)	Dipole S/N	Probe S/N	DAE S/N
Oct. 28, 2017	Extremity	750	5.72	1.41	5.64	-1.40	1013	3971	1431
Oct. 28, 2017	Extremity	835	6.28	1.55	6.20	-1.27	4d121	3971	1431
Oct. 28, 2017	Extremity	1750	19.80	4.92	19.68	-0.61	1055	3971	1431
Oct. 28, 2017	Extremity	1900	21.10	5.33	21.32	1.04	5d036	3971	1431
Oct. 28, 2017	Extremity	2300	23.20	5.95	23.80	2.59	1004	3971	1431
Oct. 28, 2017	Extremity	2600	24.30	5.61	22.44	-7.65	1020	3971	1431

**<QCNA364A>**

Test Date	Mode	Frequency (MHz)	1W Target SAR-10g (W/kg)	Measured SAR-10g (W/kg)	Normalized to 1W SAR-10g (W/kg)	Deviation (%)	Dipole S/N	Probe S/N	DAE S/N
Oct. 20, 2017	Extremity	2450	23.40	5.46	21.84	-6.67	737	3971	1431
Oct. 28, 2017	Extremity	2450	23.40	5.64	22.56	-3.59	737	7375	579
Oct. 28, 2017	Extremity	5250	21.30	2.17	21.70	1.88	1019	7375	579
Oct. 28, 2017	Extremity	5600	22.30	2.08	20.80	-6.73	1019	7375	579
Oct. 28, 2017	Extremity	5800	21.30	2.24	22.40	5.16	1019	7375	579

**Note:**

Comparing to the reference SAR value provided by SPEAG, the validation data should be within its specification of 10 %. The result indicates the system check can meet the variation criterion and the plots can be referred to Appendix A of this report.

## FCC SAR Test Report

### 4.6 Maximum Output Power

#### 4.6.1 Maximum Target Conducted Power

The maximum conducted average power (Unit: dBm) including tune-up tolerance is shown as below.

Mode	WCDMA Band II	WCDMA Band IV	WCDMA Band V
RMC 12.2K	24.0	24.0	24.0
HSDPA	23.0	23.0	23.0
HSUPA	22.0	22.0	22.0

Mode	LTE 2	LTE 4	LTE 5	LTE 7
Maximum Target Power	24.0	24.0	24.0	23.0

Mode	LTE 12	LTE 13	LTE 25	LTE 26
Maximum Target Power	24.0	24.0	24.0	24.0

Mode	LTE 30	LTE 41
Maximum Target Power	23.0	23.0

# FCC SAR Test Report

<QCNFA364A>

Mode	2.4G WLAN
802.11b	Ant-0 / Ant-1 Ch01: 20.0 Ch02-10: 20.5 Ch11: 20.0  Ant-0+1 Ch01: 23.0 Ch06: 23.5 Ch11: 23.0
802.11g	Ant-0 / Ant-1 Ch01: 17.0 Ch02:18.0 Ch03-10: 19.5 Ch11: 16.0  Ant-0+1 Ch01: 20.0 Ch02:21.0 Ch03-10: 22.5 Ch11: 19.0
802.11n HT20	Ant-0 / Ant-1 Ch01:17.0 Ch02-10:19.5 Ch11:16.0  Ant-0+1 Ch01: 20.0 Ch02-10: 22.5 Ch11: 19.0
802.11n HT40	Ant-0 / Ant-1 Ch03:13.0 Ch04:15.0 Ch05-07:18.5 Ch08:14.5 Ch09: 12.0  Ant-0+1 Ch03:16.0 Ch04:18.0 Ch05-07:22.5 Ch08:17.5 Ch09: 15.0

# FCC SAR Test Report

Mode	5.2G WLAN	5.3G WLAN	5.6G WLAN	5.8G WLAN
802.11a	Ant-0 / Ant-1: 15.0  Ant-0+1: 18.0	Ant-0 / Ant-1 Ch52-60: 19.0 Ch64: 17.0  Ant-0+1 Ch52-60: 22.0 Ch64: 20.0	Ant-0 / Ant-1 Ch100: 17.0 Ch104-136: 19.0 Ch140: 16.5 Ch144: 19.0 Ant-0+1: Ch100: 20.0 Ch104-136: 22.0 Ch140: 19.5 Ch144: 22.0	Ant-0 / Ant-1 Ch149: 17.0 Ch153-165: 19.0  Ant-0+1 Ch149: 20.0 Ch153-165: 22.0
802.11n HT20	Ant-0 / Ant-1: 15.0  Ant-0+1: 18.0	Ant-0 / Ant-1 Ch52-60: 19.0 Ch64: 17.0  Ant-0+1 Ch52-60: 22.0 Ch64: 20.0	Ant-0 / Ant-1 Ch100: 17.0 Ch104-136: 19.0 Ch140: 16.0 Ch144: 19.0 Ant-0+1: Ch100: 20.0 Ch104-136: 22.0 Ch140: 19.0 Ch144: 22.0	Ant-0 / Ant-1 Ch149: 17.0 Ch153-165: 19.0  Ant-0+1 Ch149: 20.0 Ch153-165: 22.0
802.11n HT40	Ant-0 / Ant-1: 15.0  Ant-0+1: 18.0	Ant-0 / Ant-1 Ch54: 19.0 Ch62: 17.0 Ant-0+1 Ch54: 22.0 Ch62: 20.0	Ant-0 / Ant-1 Ch102: 17.0 Ch110-142: 19.0 Ant-0+1 Ch102: 20.0 Ch110-142: 22.0	Ant-0 / Ant-1 Ch151: 14.5 Ch159: 19.0 Ant-0+1 Ch151: 17.5 Ch159: 22.0
802.11ac VHT80	Ant-0 / Ant-1: 15.0  Ant-0+1: 18.0	Ant-0 / Ant-1: 14.0  Ant-0+1: 17.0	Ant-0 / Ant-1 Ch106: 14.5 Ch138: 18.0 Ant-0+1: Ch106: 17.5 Ch138: 21.0	Ant-0 / Ant-1: 14.0  Ant-0+1: 17.0

Mode	2.4G Bluetooth
Bluetooth DH	Ch00:5.0 Ch39-78:7.0
Bluetooth LE	3.0

# FCC SAR Test Report

## 4.6.2 Measured Conducted Power Result

The measuring conducted average power (Unit: dBm) is shown as below.

Band Channel	WCDMA Band II			WCDMA Band IV			WCDMA Band V			3GPP MPR (dB)
	9262	9400	9538	1312	1413	1513	4132	4182	4233	
Frequency (MHz)	1852.4	1880.0	1907.6	1712.4	1732.6	1752.6	826.4	836.4	846.6	
RMC 12.2K	22.86	22.87	22.82	22.99	22.95	22.98	22.80	22.83	22.86	-
HSDPA Subtest-1	21.80	21.81	21.76	21.70	21.64	21.65	21.62	21.65	21.68	0
HSDPA Subtest-2	21.82	21.83	21.78	21.75	21.69	21.70	21.65	21.68	21.71	0
HSDPA Subtest-3	21.30	21.31	21.26	21.25	21.19	21.20	21.15	21.18	21.21	0.5
HSDPA Subtest-4	21.29	21.30	21.25	21.24	21.18	21.19	21.14	21.17	21.20	0.5
HSUPA Subtest-1	21.48	21.49	21.42	21.50	21.44	21.45	21.38	21.41	21.44	0
HSUPA Subtest-2	20.85	20.86	20.81	20.85	20.79	20.80	20.69	20.72	20.75	2
HSUPA Subtest-3	20.44	20.45	20.40	20.43	20.37	20.38	20.35	20.38	20.41	1
HSUPA Subtest-4	20.70	20.71	20.66	20.73	20.67	20.68	20.94	20.97	21.00	2
HSUPA Subtest-5	21.89	21.90	21.85	21.86	21.80	21.81	21.77	21.80	21.83	0



# FCC SAR Test Report

LTE Band 2										
BW (MHz)	RB Size	RB Offset	QPSK				16QAM			
			Low CH 18700	Mid CH 18900	High CH 19100	3GPP MPR (dB)	Low CH 18607	Mid CH 18900	High CH 19193	3GPP MPR (dB)
			1860.0 MHz	1880.0 MHz	1900.0 MHz		1850.7 MHz	1880.0 MHz	1909.3 MHz	
20	1	0	22.96	23.01	22.98	0	21.99	22.04	22.01	1
	1	50	22.87	22.92	22.89	0	21.90	21.95	21.92	1
	1	99	22.66	22.71	22.68	0	21.69	21.74	21.71	1
	50	0	21.99	22.04	22.01	1	21.02	21.07	21.04	2
	50	25	21.97	22.02	21.99	1	21.00	21.05	21.02	2
	50	50	21.92	21.97	21.94	1	20.95	21.00	20.97	2
100	0	21.91	21.96	21.93	1	20.94	20.99	20.96	2	
BW (MHz)	RB Size	RB Offset	QPSK				16QAM			
			Low CH 18675	Mid CH 18900	High CH 19125	3GPP MPR (dB)	Low CH 18675	Mid CH 18900	High CH 19125	3GPP MPR (dB)
			1857.5 MHz	1880.0 MHz	1902.5 MHz		1857.5 MHz	1880.0 MHz	1902.5 MHz	
15	1	0	22.91	22.96	22.93	0	21.94	21.99	21.96	1
	1	37	22.82	22.87	22.84	0	21.85	21.90	21.87	1
	1	74	22.61	22.66	22.63	0	21.64	21.69	21.66	1
	36	0	21.94	21.99	21.96	1	20.97	21.02	20.99	2
	36	19	21.92	21.97	21.94	1	20.95	21.00	20.97	2
	36	39	21.87	21.92	21.89	1	20.90	20.95	20.92	2
75	0	21.86	21.91	21.88	1	20.89	20.94	20.91	2	
BW (MHz)	RB Size	RB Offset	QPSK				16QAM			
			Low CH 18650	Mid CH 18900	High CH 19150	3GPP MPR (dB)	Low CH 18650	Mid CH 18900	High CH 19150	3GPP MPR (dB)
			1855.0 MHz	1880.0 MHz	1905.0 MHz		1855.0 MHz	1880.0 MHz	1905.0 MHz	
10	1	0	22.85	22.90	22.87	0	21.88	21.93	21.90	1
	1	24	22.76	22.81	22.78	0	21.79	21.84	21.81	1
	1	49	22.55	22.60	22.57	0	21.58	21.63	21.60	1
	25	0	21.88	21.93	21.90	1	20.91	20.96	20.93	2
	25	12	21.86	21.91	21.88	1	20.89	20.94	20.91	2
	25	25	21.81	21.86	21.83	1	20.84	20.89	20.86	2
50	0	21.80	21.85	21.82	1	20.83	20.88	20.85	2	
BW (MHz)	RB Size	RB Offset	QPSK				16QAM			
			Low CH 18625	Mid CH 18900	High CH 19175	3GPP MPR (dB)	Low CH 18625	Mid CH 18900	High CH 19175	3GPP MPR (dB)
			1852.5 MHz	1880.0 MHz	1907.5 MHz		1852.5 MHz	1880.0 MHz	1907.5 MHz	
5	1	0	22.82	22.87	22.84	0	21.85	21.90	21.87	1
	1	12	22.73	22.78	22.75	0	21.76	21.81	21.78	1
	1	24	22.52	22.57	22.54	0	21.55	21.60	21.57	1
	12	0	21.85	21.90	21.87	1	20.88	20.93	20.90	2
	12	6	21.83	21.88	21.85	1	20.86	20.91	20.88	2
	12	13	21.78	21.83	21.80	1	20.81	20.86	20.83	2
25	0	21.77	21.82	21.79	1	20.80	20.85	20.82	2	
BW (MHz)	RB Size	RB Offset	QPSK				16QAM			
			Low CH 18615	Mid CH 18900	High CH 19185	3GPP MPR (dB)	Low CH 18615	Mid CH 18900	High CH 19185	3GPP MPR (dB)
			1851.5 MHz	1880.0 MHz	1908.5 MHz		1851.5 MHz	1880.0 MHz	1908.5 MHz	
3	1	0	22.77	22.82	22.79	0	21.80	21.85	21.82	1
	1	7	22.68	22.73	22.70	0	21.71	21.76	21.73	1
	1	14	22.47	22.52	22.49	0	21.50	21.55	21.52	1
	8	0	21.80	21.85	21.82	1	20.83	20.88	20.85	2
	8	3	21.78	21.83	21.80	1	20.81	20.86	20.83	2
	8	7	21.73	21.78	21.75	1	20.76	20.81	20.78	2
15	0	21.72	21.77	21.74	1	20.75	20.80	20.77	2	
BW (MHz)	RB Size	RB Offset	QPSK				16QAM			
			Low CH 18607	Mid CH 18900	High CH 19193	3GPP MPR (dB)	Low CH 18607	Mid CH 18900	High CH 19193	3GPP MPR (dB)
			1850.7 MHz	1880.0 MHz	1909.3 MHz		1850.7 MHz	1880.0 MHz	1909.3 MHz	
1.4	1	0	22.73	22.78	22.75	0	21.76	21.81	21.78	1
	1	2	22.64	22.69	22.66	0	21.67	21.72	21.69	1
	1	5	22.43	22.48	22.45	0	21.46	21.51	21.48	1
	3	0	22.08	22.13	22.10	0	21.11	21.16	21.13	1
	3	1	22.06	22.11	22.08	0	21.09	21.14	21.11	1
	3	3	22.01	22.06	22.03	0	21.04	21.09	21.06	1
6	0	21.68	21.73	21.70	1	20.71	20.76	20.73	2	

# FCC SAR Test Report

LTE Band 4										
BW (MHz)	RB Size	RB Offset	QPSK				16QAM			
			Low CH 20050	Mid CH 20175	High CH 20300	3GPP MPR (dB)	Low CH 20050	Mid CH 20175	High CH 20300	3GPP MPR (dB)
			1720.0 MHz	1732.5 MHz	1745.0 MHz		1720.0 MHz	1732.5 MHz	1745.0 MHz	
20	1	0	23.19	23.23	23.20	0	22.27	22.31	22.28	1
	1	50	23.12	23.16	23.13	0	22.20	22.24	22.21	1
	1	99	22.88	22.92	22.89	0	21.96	22.00	21.97	1
	50	0	22.14	22.18	22.15	1	21.22	21.26	21.23	2
	50	25	22.12	22.16	22.13	1	21.20	21.24	21.21	2
	50	50	22.09	22.13	22.10	1	21.17	21.21	21.18	2
100	0	22.04	22.08	22.05	1	21.12	21.16	21.13	2	
BW (MHz)	RB Size	RB Offset	QPSK				16QAM			
			Low CH 20025	Mid CH 20175	High CH 20325	3GPP MPR (dB)	Low CH 20025	Mid CH 20175	High CH 20325	3GPP MPR (dB)
			1717.5 MHz	1732.5 MHz	1747.5 MHz		1717.5 MHz	1732.5 MHz	1747.5 MHz	
15	1	0	23.16	23.20	23.17	0	22.24	22.28	22.25	1
	1	37	23.09	23.13	23.10	0	22.17	22.21	22.18	1
	1	74	22.85	22.89	22.86	0	21.93	21.97	21.94	1
	36	0	22.11	22.15	22.12	1	21.19	21.23	21.20	2
	36	19	22.09	22.13	22.10	1	21.17	21.21	21.18	2
	36	39	22.06	22.10	22.07	1	21.14	21.18	21.15	2
75	0	22.01	22.05	22.02	1	21.09	21.13	21.10	2	
BW (MHz)	RB Size	RB Offset	QPSK				16QAM			
			Low CH 20000	Mid CH 20175	High CH 20350	3GPP MPR (dB)	Low CH 20000	Mid CH 20175	High CH 20350	3GPP MPR (dB)
			1715.0 MHz	1732.5 MHz	1750.0 MHz		1715.0 MHz	1732.5 MHz	1750.0 MHz	
10	1	0	23.12	23.16	23.13	0	22.20	22.24	22.21	1
	1	24	23.05	23.09	23.06	0	22.13	22.17	22.14	1
	1	49	22.81	22.85	22.82	0	21.89	21.93	21.90	1
	25	0	22.07	22.11	22.08	1	21.15	21.19	21.16	2
	25	12	22.05	22.09	22.06	1	21.13	21.17	21.14	2
	25	25	22.02	22.06	22.03	1	21.10	21.14	21.11	2
50	0	21.97	22.01	21.98	1	21.05	21.09	21.06	2	
BW (MHz)	RB Size	RB Offset	QPSK				16QAM			
			Low CH 19975	Mid CH 20175	High CH 20375	3GPP MPR (dB)	Low CH 19975	Mid CH 20175	High CH 20375	3GPP MPR (dB)
			1712.5 MHz	1732.5 MHz	1752.5 MHz		1712.5 MHz	1732.5 MHz	1752.5 MHz	
5	1	0	23.06	23.10	23.07	0	22.14	22.18	22.15	1
	1	12	22.99	23.03	23.00	0	22.07	22.11	22.08	1
	1	24	22.75	22.79	22.76	0	21.83	21.87	21.84	1
	12	0	22.01	22.05	22.02	1	21.09	21.13	21.10	2
	12	6	21.99	22.03	22.00	1	21.07	21.11	21.08	2
	12	13	21.96	22.00	21.97	1	21.04	21.08	21.05	2
25	0	21.91	21.95	21.92	1	20.99	21.03	21.00	2	
BW (MHz)	RB Size	RB Offset	QPSK				16QAM			
			Low CH 19965	Mid CH 20175	High CH 20385	3GPP MPR (dB)	Low CH 19965	Mid CH 20175	High CH 20385	3GPP MPR (dB)
			1711.5 MHz	1732.5 MHz	1753.5 MHz		1711.5 MHz	1732.5 MHz	1753.5 MHz	
3	1	0	23.02	23.06	23.03	0	22.10	22.14	22.11	1
	1	7	22.95	22.99	22.96	0	22.03	22.07	22.04	1
	1	14	22.71	22.75	22.72	0	21.79	21.83	21.80	1
	8	0	21.97	22.01	21.98	1	21.05	21.09	21.06	2
	8	3	21.95	21.99	21.96	1	21.03	21.07	21.04	2
	8	7	21.92	21.96	21.93	1	21.00	21.04	21.01	2
15	0	21.87	21.91	21.88	1	20.95	20.99	20.96	2	
BW (MHz)	RB Size	RB Offset	QPSK				16QAM			
			Low CH 19957	Mid CH 20175	High CH 20393	3GPP MPR (dB)	Low CH 19957	Mid CH 20175	High CH 20393	3GPP MPR (dB)
			1710.7 MHz	1732.5 MHz	1754.3 MHz		1710.7 MHz	1732.5 MHz	1754.3 MHz	
1.4	1	0	22.97	23.01	22.98	0	22.05	22.09	22.06	1
	1	2	22.90	22.94	22.91	0	21.98	22.02	21.99	1
	1	5	22.66	22.70	22.67	0	21.74	21.78	21.75	1
	3	0	22.05	22.09	22.06	0	21.13	21.17	21.14	1
	3	1	22.03	22.07	22.04	0	21.11	21.15	21.12	1
	3	3	22.01	22.04	22.01	0	21.08	21.12	21.09	1
6	0	21.82	21.86	21.83	1	20.90	20.94	20.91	2	

# FCC SAR Test Report

LTE Band 5											
BW (MHz)	RB Size	RB Offset	QPSK				3GPP MPR (dB)	16QAM			
			Low CH 20450	Mid CH 20525	High CH 20600	Low CH 20450		Mid CH 20525	High CH 20600	3GPP MPR (dB)	
			829.0 MHz	836.5 MHz	844.0 MHz	829.0 MHz		836.5 MHz	844.0 MHz		
10	1	0	22.80	22.87	22.91	0	21.85	21.92	21.96	1	
	1	24	22.77	22.84	22.88	0	21.82	21.89	21.93	1	
	1	49	22.69	22.76	22.80	0	21.74	21.81	21.85	1	
	25	0	21.73	21.80	21.84	1	20.78	20.85	20.89	2	
	25	12	21.76	21.83	21.87	1	20.81	20.88	20.92	2	
	25	25	21.66	21.73	21.77	1	20.71	20.78	20.82	2	
50	0	21.75	21.82	21.86	1	20.80	20.87	20.91	2		
BW (MHz)	RB Size	RB Offset	QPSK				3GPP MPR (dB)	16QAM			
			Low CH 20425	Mid CH 20525	High CH 20625	Low CH 20425		Mid CH 20525	High CH 20625	3GPP MPR (dB)	
			826.5 MHz	836.5 MHz	846.5 MHz	826.5 MHz		836.5 MHz	846.5 MHz		
5	1	0	22.76	22.83	22.87	0	21.81	21.88	21.92	1	
	1	12	22.73	22.80	22.84	0	21.78	21.85	21.89	1	
	1	24	22.65	22.72	22.76	0	21.70	21.77	21.81	1	
	12	0	21.69	21.76	21.80	1	20.74	20.81	20.85	2	
	12	6	21.72	21.79	21.83	1	20.77	20.84	20.88	2	
	12	13	21.62	21.69	21.73	1	20.67	20.74	20.78	2	
25	0	21.71	21.78	21.82	1	20.76	20.83	20.87	2		
BW (MHz)	RB Size	RB Offset	QPSK				3GPP MPR (dB)	16QAM			
			Low CH 20415	Mid CH 20525	High CH 20635	Low CH 20415		Mid CH 20525	High CH 20635	3GPP MPR (dB)	
			825.5 MHz	836.5 MHz	847.5 MHz	825.5 MHz		836.5 MHz	847.5 MHz		
3	1	0	22.73	22.80	22.84	0	21.78	21.85	21.89	1	
	1	7	22.70	22.77	22.81	0	21.75	21.82	21.86	1	
	1	14	22.62	22.69	22.73	0	21.67	21.74	21.78	1	
	8	0	21.66	21.73	21.77	1	20.71	20.78	20.82	2	
	8	3	21.69	21.76	21.80	1	20.74	20.81	20.85	2	
	8	7	21.59	21.66	21.70	1	20.64	20.71	20.75	2	
15	0	21.68	21.75	21.79	1	20.73	20.80	20.84	2		
BW (MHz)	RB Size	RB Offset	QPSK				3GPP MPR (dB)	16QAM			
			Low CH 20407	Mid CH 20525	High CH 20643	Low CH 20407		Mid CH 20525	High CH 20643	3GPP MPR (dB)	
			824.7 MHz	836.5 MHz	848.3 MHz	824.7 MHz		836.5 MHz	848.3 MHz		
1.4	1	0	22.67	22.74	22.78	0	21.72	21.79	21.83	1	
	1	2	22.64	22.71	22.75	0	21.69	21.76	21.80	1	
	1	5	22.56	22.63	22.67	0	21.61	21.68	21.72	1	
	3	0	22.08	22.15	22.19	0	21.13	21.20	21.24	1	
	3	1	22.11	22.18	22.22	0	21.16	21.23	21.27	1	
	3	3	22.01	22.08	22.12	0	21.06	21.13	21.17	1	
6	0	21.62	21.69	21.73	1	20.67	20.74	20.78	2		

# FCC SAR Test Report

LTE Band 7											
BW (MHz)	RB Size	RB Offset	QPSK				3GPP MPR (dB)	16QAM			
			Low CH 20850	Mid CH 21100	High CH 21350	Low CH 20850		Mid CH 21100	High CH 21350	3GPP MPR (dB)	
			2510.0 MHz	2535.0 MHz	2560.0 MHz	2510.0 MHz		2535.0 MHz	2560.0 MHz		
20	1	0	22.81	22.88	22.43	0	21.87	21.94	21.49	1	
	1	50	22.78	22.85	22.40	0	21.84	21.91	21.46	1	
	1	99	22.16	22.23	21.78	0	21.22	21.29	20.84	1	
	50	0	21.90	21.97	21.52	1	20.96	20.99	20.58	2	
	50	25	21.84	21.91	21.46	1	20.90	20.97	20.52	2	
	50	50	21.60	21.67	21.22	1	20.66	20.73	20.28	2	
100	0	21.71	21.78	21.33	1	20.77	20.84	20.39	2		
BW (MHz)	RB Size	RB Offset	QPSK				3GPP MPR (dB)	16QAM			
			Low CH 20825	Mid CH 21100	High CH 21375	Low CH 20825		Mid CH 21100	High CH 21375	3GPP MPR (dB)	
			2507.5 MHz	2535.0 MHz	2562.5 MHz	2507.5 MHz		2535.0 MHz	2562.5 MHz		
15	1	0	22.78	22.85	22.40	0	21.84	21.91	21.46	1	
	1	37	22.75	22.82	22.37	0	21.81	21.88	21.43	1	
	1	74	22.13	22.20	21.75	0	21.19	21.26	20.81	1	
	36	0	21.87	21.94	21.49	1	20.93	20.96	20.55	2	
	36	19	21.81	21.88	21.43	1	20.87	20.94	20.49	2	
	36	39	21.57	21.64	21.19	1	20.63	20.70	20.25	2	
	75	0	21.68	21.75	21.30	1	20.74	20.81	20.36	2	
BW (MHz)	RB Size	RB Offset	QPSK				3GPP MPR (dB)	16QAM			
			Low CH 20800	Mid CH 21100	High CH 21400	Low CH 20800		Mid CH 21100	High CH 21400	3GPP MPR (dB)	
			2505.0 MHz	2535.0 MHz	2565.0 MHz	2505.0 MHz		2535.0 MHz	2565.0 MHz		
10	1	0	22.72	22.79	22.34	0	21.78	21.85	21.40	1	
	1	24	22.69	22.76	22.31	0	21.75	21.82	21.37	1	
	1	49	22.07	22.14	21.69	0	21.13	21.20	20.75	1	
	25	0	21.81	21.88	21.43	1	20.87	20.90	20.49	2	
	25	12	21.75	21.82	21.37	1	20.81	20.88	20.43	2	
	25	25	21.51	21.58	21.13	1	20.57	20.64	20.19	2	
	50	0	21.62	21.69	21.24	1	20.68	20.75	20.30	2	
BW (MHz)	RB Size	RB Offset	QPSK				3GPP MPR (dB)	16QAM			
			Low CH 20775	Mid CH 21100	High CH 21425	Low CH 20775		Mid CH 21100	High CH 21425	3GPP MPR (dB)	
			2502.5 MHz	2535.0 MHz	2567.5 MHz	2502.5 MHz		2535.0 MHz	2567.5 MHz		
5	1	0	22.68	22.75	22.30	0	21.74	21.81	21.36	1	
	1	12	22.65	22.72	22.27	0	21.71	21.78	21.33	1	
	1	24	22.03	22.10	21.65	0	21.09	21.16	20.71	1	
	12	0	21.77	21.84	21.39	1	20.83	20.86	20.45	2	
	12	6	21.71	21.78	21.33	1	20.77	20.84	20.39	2	
	12	13	21.47	21.54	21.09	1	20.53	20.60	20.15	2	
	25	0	21.58	21.65	21.20	1	20.64	20.71	20.26	2	

# FCC SAR Test Report

LTE Band 12											
BW (MHz)	RB Size	RB Offset	QPSK				3GPP MPR (dB)	16QAM			
			Low CH 23060	Mid CH 23095	High CH 23130	Low CH 23060		Mid CH 23095	High CH 23130	3GPP MPR (dB)	
			704.0 MHz	707.5 MHz	711.0 MHz	704.0 MHz		707.5 MHz	711.0 MHz		
10	1	0	23.34	23.37	23.23	0	22.39	22.42	22.28	1	
	1	24	23.12	23.15	23.01	0	22.17	22.20	22.06	1	
	1	49	23.16	23.19	23.05	0	22.21	22.24	22.10	1	
	25	0	22.14	22.17	22.03	1	21.19	21.22	21.08	2	
	25	12	22.11	22.14	22.00	1	21.16	21.19	21.05	2	
	25	25	22.08	22.11	21.97	1	21.13	21.16	21.02	2	
50	0	22.11	22.14	22.00	1	21.16	21.19	21.05	2		
BW (MHz)	RB Size	RB Offset	QPSK				3GPP MPR (dB)	16QAM			
			Low CH 23035	Mid CH 23095	High CH 23155	Low CH 23035		Mid CH 23095	High CH 23155	3GPP MPR (dB)	
			701.5 MHz	707.5 MHz	713.5 MHz	701.5 MHz		707.5 MHz	713.5 MHz		
5	1	0	23.30	23.33	23.19	0	22.35	22.38	22.24	1	
	1	12	23.08	23.11	22.97	0	22.13	22.16	22.02	1	
	1	24	23.12	23.15	23.01	0	22.17	22.20	22.06	1	
	12	0	22.10	22.13	21.99	1	21.15	21.18	21.04	2	
	12	6	22.07	22.10	21.96	1	21.12	21.15	21.01	2	
	12	13	22.04	22.07	21.93	1	21.09	21.12	20.98	2	
25	0	22.07	22.10	21.96	1	21.12	21.15	21.01	2		
BW (MHz)	RB Size	RB Offset	QPSK				3GPP MPR (dB)	16QAM			
			Low CH 23025	Mid CH 23095	High CH 23165	Low CH 23025		Mid CH 23095	High CH 23165	3GPP MPR (dB)	
			700.5 MHz	707.5 MHz	714.5 MHz	700.5 MHz		707.5 MHz	714.5 MHz		
3	1	0	23.27	23.30	23.16	0	22.32	22.35	22.21	1	
	1	7	23.05	23.08	22.94	0	22.10	22.13	21.99	1	
	1	14	23.09	23.12	22.98	0	22.14	22.17	22.03	1	
	8	0	22.07	22.10	21.96	1	21.12	21.15	21.01	2	
	8	3	22.04	22.07	21.93	1	21.09	21.12	20.98	2	
	8	7	22.01	22.04	21.90	1	21.06	21.09	20.95	2	
15	0	22.04	22.07	21.93	1	21.09	21.12	20.98	2		
BW (MHz)	RB Size	RB Offset	QPSK				3GPP MPR (dB)	16QAM			
			Low CH 23017	Mid CH 23095	High CH 23173	Low CH 23017		Mid CH 23095	High CH 23173	3GPP MPR (dB)	
			699.7 MHz	707.5 MHz	715.3 MHz	699.7 MHz		707.5 MHz	715.3 MHz		
1.4	1	0	23.23	23.26	23.12	0	22.28	22.31	22.17	1	
	1	2	23.01	23.04	22.90	0	22.06	22.09	21.95	1	
	1	5	23.05	23.08	22.94	0	22.10	22.13	21.99	1	
	3	0	22.03	22.06	22.07	0	21.08	21.11	21.07	1	
	3	1	22.40	22.03	22.04	0	21.45	21.08	21.04	1	
	3	3	22.02	22.04	22.01	0	21.07	21.05	21.01	1	
6	0	22.00	22.03	21.89	1	21.05	21.08	20.94	2		

# FCC SAR Test Report

LTE Band 13										
BW (MHz)	RB Size	RB Offset	QPSK				16QAM			
			Mid CH 23230	782.0 MHz	3GPP MPR (dB)	Mid CH 23230	782.0 MHz	3GPP MPR (dB)		
10	1	0		22.98		0		22.04		1
	1	24		22.06		0		21.12		1
	1	49		22.85		0		21.91		1
	25	0		21.93		1		20.99		2
	25	12		21.92		1		20.98		2
	25	25		21.91		1		20.97		2
	50	0		22.05		1		21.11		2
BW (MHz)	RB Size	RB Offset	QPSK				16QAM			
			Low CH 23205	Mid CH 23230	High CH 23255	3GPP MPR (dB)	Low CH 23205	Mid CH 23230	High CH 23255	3GPP MPR (dB)
5	1	0	779.5 MHz	782.0 MHz	784.5 MHz	0	779.5 MHz	782.0 MHz	784.5 MHz	1
	1	12	22.15	22.80	22.93	0	21.22	21.87	22.00	1
	1	24	22.11	22.76	22.89	0	21.18	21.83	21.96	1
	1	0	22.04	22.69	22.82	0	21.11	21.76	21.89	1
	12	0	21.26	21.81	21.94	1	20.33	20.88	21.01	2
	12	6	21.25	21.80	21.93	1	20.32	20.87	21.00	2
	12	13	21.09	21.64	21.77	1	20.16	20.71	20.84	2
25	0	21.27	21.82	21.95	1	20.34	20.89	21.02	2	

# FCC SAR Test Report

LTE Band 25										
BW (MHz)	RB Size	RB Offset	QPSK				16QAM			
			Low CH 26140	Mid CH 26365	High CH 26590	3GPP MPR (dB)	Low CH 26140	Mid CH 26365	High CH 26590	3GPP MPR (dB)
			1860.0 MHz	1882.5 MHz	1905.0 MHz		1860.0 MHz	1882.5 MHz	1905.0 MHz	
20	1	0	23.12	23.01	23.17	0	22.19	22.08	22.24	1
	1	50	23.06	22.95	23.11	0	22.13	22.02	22.18	1
	1	99	22.68	22.57	22.73	0	21.75	21.64	21.80	1
	50	0	22.08	21.97	22.13	1	21.15	21.04	21.20	2
	50	25	21.93	21.82	21.98	1	21.00	20.89	21.05	2
	50	50	21.75	21.64	21.80	1	20.82	20.71	20.87	2
	100	0	21.96	21.85	22.01	1	21.03	20.92	21.08	2
BW (MHz)	RB Size	RB Offset	QPSK				16QAM			
			Low CH 26115	Mid CH 26365	High CH 26615	3GPP MPR (dB)	Low CH 26115	Mid CH 26365	High CH 26615	3GPP MPR (dB)
			1857.5 MHz	1882.5 MHz	1907.5 MHz		1857.5 MHz	1882.5 MHz	1907.5 MHz	
15	1	0	23.08	22.97	23.13	0	22.15	22.04	22.20	1
	1	37	23.02	22.91	23.07	0	22.09	21.98	22.14	1
	1	74	22.64	22.53	22.69	0	21.71	21.60	21.76	1
	36	0	22.04	21.93	22.09	1	21.11	21.00	21.16	2
	36	19	21.89	21.78	21.94	1	20.96	20.85	21.01	2
	36	39	21.71	21.60	21.76	1	20.78	20.67	20.83	2
	75	0	21.92	21.81	21.97	1	20.99	20.88	21.04	2
BW (MHz)	RB Size	RB Offset	QPSK				16QAM			
			Low CH 26090	Mid CH 26365	High CH 26640	3GPP MPR (dB)	Low CH 26090	Mid CH 26365	High CH 26640	3GPP MPR (dB)
			1855.0 MHz	1882.5 MHz	1910.0 MHz		1855.0 MHz	1882.5 MHz	1910.0 MHz	
10	1	0	23.05	22.94	23.10	0	22.12	22.01	22.17	1
	1	24	22.99	22.88	23.04	0	22.06	21.95	22.11	1
	1	49	22.61	22.50	22.66	0	21.68	21.57	21.73	1
	25	0	22.01	21.90	22.06	1	21.08	20.97	21.13	2
	25	12	21.86	21.75	21.91	1	20.93	20.82	20.98	2
	25	25	21.68	21.57	21.73	1	20.75	20.64	20.80	2
	50	0	21.89	21.78	21.94	1	20.96	20.85	21.01	2
BW (MHz)	RB Size	RB Offset	QPSK				16QAM			
			Low CH 26065	Mid CH 26365	High CH 26665	3GPP MPR (dB)	Low CH 26065	Mid CH 26365	High CH 26665	3GPP MPR (dB)
			1852.5 MHz	1882.5 MHz	1912.5 MHz		1852.5 MHz	1882.5 MHz	1912.5 MHz	
5	1	0	23.00	22.89	23.05	0	22.07	21.96	22.12	1
	1	12	22.94	22.83	22.99	0	22.01	21.90	22.06	1
	1	24	22.56	22.45	22.61	0	21.63	21.52	21.68	1
	12	0	21.96	21.85	22.01	1	21.03	20.92	21.08	2
	12	6	21.81	21.70	21.86	1	20.88	20.77	20.93	2
	12	13	21.63	21.52	21.68	1	20.70	20.59	20.75	2
	25	0	21.84	21.73	21.89	1	20.91	20.80	20.96	2
BW (MHz)	RB Size	RB Offset	QPSK				16QAM			
			Low CH 26055	Mid CH 26365	High CH 26675	3GPP MPR (dB)	Low CH 26055	Mid CH 26365	High CH 26675	3GPP MPR (dB)
			1851.5 MHz	1882.5 MHz	1913.5 MHz		1851.5 MHz	1882.5 MHz	1913.5 MHz	
3	1	0	22.96	22.85	23.01	0	22.03	21.92	22.08	1
	1	7	22.90	22.79	22.95	0	21.97	21.86	22.02	1
	1	14	22.52	22.41	22.57	0	21.59	21.48	21.64	1
	8	0	21.92	21.81	21.97	1	20.99	20.88	21.04	2
	8	3	21.77	21.66	21.82	1	20.84	20.73	20.89	2
	8	7	21.59	21.48	21.64	1	20.66	20.55	20.71	2
	15	0	21.80	21.69	21.85	1	20.87	20.76	20.92	2
BW (MHz)	RB Size	RB Offset	QPSK				16QAM			
			Low CH 26047	Mid CH 26365	High CH 26683	3GPP MPR (dB)	Low CH 26047	Mid CH 26365	High CH 26683	3GPP MPR (dB)
			1850.7 MHz	1882.5 MHz	1914.3 MHz		1850.7 MHz	1882.5 MHz	1914.3 MHz	
1.4	1	0	22.92	22.81	22.97	0	21.99	21.88	22.04	1
	1	2	22.86	22.75	22.91	0	21.93	21.82	21.98	1
	1	5	22.48	22.37	22.53	0	21.55	21.44	21.60	1
	3	0	22.57	22.34	22.50	0	21.52	21.41	21.57	1
	3	1	22.30	22.19	22.35	0	21.37	21.26	21.42	1
	3	3	22.12	22.01	22.17	0	21.19	21.08	21.24	1
	6	0	21.76	21.65	21.81	1	20.83	20.72	20.88	2

# FCC SAR Test Report

LTE Band 26										
BW (MHz)	RB Size	RB Offset	QPSK				16QAM			
			Low CH 26765	Mid CH 26865	High CH 26965	3GPP MPR (dB)	Low CH 26765	Mid CH 26865	High CH 26965	3GPP MPR (dB)
			821.5 MHz	831.5 MHz	841.5 MHz		821.5 MHz	831.5 MHz	841.5 MHz	
15	1	0	22.97	22.90	23.04	0	22.04	21.97	22.11	1
	1	37	22.87	22.80	22.94	0	21.94	21.87	22.01	1
	1	74	22.71	22.64	22.78	0	21.78	21.71	21.85	1
	36	0	22.01	21.94	22.08	1	21.08	21.01	21.15	2
	36	19	21.98	21.91	22.05	1	21.05	20.98	21.12	2
	36	39	21.80	21.73	21.87	1	20.87	20.80	20.94	2
	75	0	22.00	21.93	22.07	1	21.07	21.00	21.14	2
BW (MHz)	RB Size	RB Offset	QPSK				16QAM			
			Low CH 26740	Mid CH 26865	High CH 26990	3GPP MPR (dB)	Low CH 26740	Mid CH 26865	High CH 26990	3GPP MPR (dB)
			819.0 MHz	831.5 MHz	844.0 MHz		819.0 MHz	831.5 MHz	844.0 MHz	
10	1	0	22.93	22.86	23.00	0	22.00	21.93	22.07	1
	1	24	22.83	22.76	22.90	0	21.90	21.83	21.97	1
	1	49	22.67	22.60	22.74	0	21.74	21.67	21.81	1
	25	0	21.97	21.90	22.04	1	21.04	20.97	21.11	2
	25	12	21.94	21.87	22.01	1	21.01	20.94	21.08	2
	25	25	21.76	21.69	21.83	1	20.83	20.76	20.90	2
	50	0	21.96	21.89	22.03	1	21.03	20.96	21.10	2
BW (MHz)	RB Size	RB Offset	QPSK				16QAM			
			Low CH 26715	Mid CH 26865	High CH 27015	3GPP MPR (dB)	Low CH 26715	Mid CH 26865	High CH 27015	3GPP MPR (dB)
			816.5 MHz	831.5 MHz	846.5 MHz		816.5 MHz	831.5 MHz	846.5 MHz	
5	1	0	22.87	22.80	22.94	0	21.94	21.87	22.01	1
	1	12	22.77	22.70	22.84	0	21.84	21.77	21.91	1
	1	24	22.61	22.54	22.68	0	21.68	21.61	21.75	1
	12	0	21.91	21.84	21.98	1	20.98	20.91	21.05	2
	12	6	21.88	21.81	21.95	1	20.95	20.88	21.02	2
	12	13	21.70	21.63	21.77	1	20.77	20.70	20.84	2
	25	0	21.90	21.83	21.97	1	20.97	20.90	21.04	2
BW (MHz)	RB Size	RB Offset	QPSK				16QAM			
			Low CH 26705	Mid CH 26865	High CH 27025	3GPP MPR (dB)	Low CH 26705	Mid CH 26865	High CH 27025	3GPP MPR (dB)
			815.5 MHz	831.5 MHz	847.5 MHz		815.5 MHz	831.5 MHz	847.5 MHz	
3	1	0	22.83	22.76	22.90	0	21.90	21.83	21.97	1
	1	7	22.73	22.66	22.80	0	21.80	21.73	21.87	1
	1	14	22.57	22.50	22.64	0	21.64	21.57	21.71	1
	8	0	21.87	21.80	21.94	1	20.94	20.87	21.01	2
	8	3	21.84	21.77	21.91	1	20.91	20.84	20.98	2
	8	7	21.66	21.59	21.73	1	20.73	20.66	20.80	2
	15	0	21.86	21.79	21.93	1	20.93	20.86	21.00	2
BW (MHz)	RB Size	RB Offset	QPSK				16QAM			
			Low CH 26697	Mid CH 26865	High CH 27033	3GPP MPR (dB)	Low CH 26697	Mid CH 26865	High CH 27033	3GPP MPR (dB)
			814.7 MHz	831.5 MHz	848.3 MHz		814.7 MHz	831.5 MHz	848.3 MHz	
1.4	1	0	22.78	22.71	22.85	0	21.85	21.78	21.92	1
	1	2	22.68	22.61	22.75	0	21.75	21.68	21.82	1
	1	5	22.52	22.45	22.59	0	21.59	21.52	21.66	1
	3	0	22.29	22.22	22.36	0	21.29	21.22	21.36	1
	3	1	22.26	22.19	22.33	0	21.26	21.19	21.33	1
	3	3	22.08	22.01	22.15	0	21.08	21.01	21.15	1
	6	0	21.81	21.74	21.88	1	20.88	20.81	20.95	2



# FCC SAR Test Report

LTE Band 30										
BW (MHz)	RB Size	RB Offset	QPSK				16QAM			
			Mid CH 27710 MHz			3GPP MPR (dB)	Mid CH 27710 MHz			3GPP MPR (dB)
10	1	0	21.85			0	20.91			1
	1	24	21.60			0	20.66			1
	1	49	21.24			0	20.30			1
	25	0	20.63			1	19.69			2
	25	12	20.61			1	19.67			2
	25	25	20.44			1	19.50			2
	50	0	20.55			1	19.61			2
BW (MHz)	RB Size	RB Offset	QPSK				16QAM			
			Low CH 27685 MHz	Mid CH 27710 MHz	High CH 27735 MHz	3GPP MPR (dB)	Low CH 27685 MHz	Mid CH 27710 MHz	High CH 27735 MHz	3GPP MPR (dB)
5	1	0	21.66	21.63	21.74	0	20.70	20.67	20.78	1
	1	12	21.60	21.57	21.68	0	20.64	20.61	20.72	1
	1	24	21.48	21.45	21.56	0	20.52	20.49	20.60	1
	12	0	20.65	20.62	20.73	1	19.69	19.66	19.77	2
	12	6	20.63	20.60	20.71	1	19.67	19.64	19.75	2
	12	13	20.45	20.42	20.53	1	19.49	19.46	19.57	2
	25	0	20.58	20.55	20.66	1	19.62	19.59	19.70	2

# FCC SAR Test Report

LTE Band 41 (Power Class 3)															
BW (MHz)	RB Size	RB Offset	QPSK						16QAM						
			L-CH 39750	M-CH 40185	M-CH 40620	M-CH 41055	H-CH 41490	3GPP MPR (dB)	L-CH 39750	M-CH 40185	M-CH 40620	M-CH 41055	H-CH 41490	3GPP MPR (dB)	
			2506.0 MHz	2549.5 MHz	2593.0 MHz	2636.5 MHz	2680.0 MHz		2506.0 MHz	2549.5 MHz	2593.0 MHz	2636.5 MHz	2680.0 MHz		
20	1	0	21.68	22.72	22.75	22.36	21.35	0	20.72	21.76	21.79	21.40	20.39	1	
	1	50	21.63	22.67	22.70	22.31	21.30	0	20.67	21.71	21.74	21.35	20.34	1	
	1	99	21.25	22.29	22.32	21.93	21.23	0	20.29	21.33	21.36	20.97	20.27	1	
	50	0	20.88	21.92	21.95	21.56	20.55	1	19.92	20.96	20.99	20.60	19.59	2	
	50	25	20.91	21.95	21.98	21.59	20.58	1	19.95	20.99	20.97	20.63	19.62	2	
	50	50	20.65	21.69	21.72	21.33	20.32	1	19.69	20.73	20.76	20.37	19.36	2	
100	0	20.83	21.87	21.90	21.51	20.50	1	19.87	20.91	20.94	20.55	19.54	2		
BW (MHz)	RB Size	RB Offset	QPSK						16QAM						
			L-CH 39725	M-CH 40173	M-CH 40620	M-CH 41068	H-CH 41515	3GPP MPR (dB)	L-CH 39725	M-CH 40173	M-CH 40620	M-CH 41068	H-CH 41515	3GPP MPR (dB)	
			2503.5 MHz	2548.3 MHz	2593.0 MHz	2637.8 MHz	2682.5 MHz		2503.5 MHz	2548.3 MHz	2593.0 MHz	2637.8 MHz	2682.5 MHz		
15	1	0	21.64	22.68	22.71	22.32	21.31	0	20.68	21.72	21.75	21.36	20.35	1	
	1	37	21.59	22.63	22.66	22.27	21.26	0	20.63	21.67	21.70	21.31	20.30	1	
	1	74	21.21	22.25	22.28	21.89	21.19	0	20.25	21.29	21.32	20.93	20.23	1	
	36	0	20.84	21.88	21.91	21.52	20.51	1	19.88	20.92	20.95	20.56	19.55	2	
	36	19	20.87	21.91	21.94	21.55	20.54	1	19.91	20.95	20.93	20.59	19.58	2	
	36	39	20.61	21.65	21.68	21.29	20.28	1	19.65	20.69	20.72	20.33	19.32	2	
75	0	20.79	21.83	21.86	21.47	20.46	1	19.83	20.87	20.90	20.51	19.50	2		
BW (MHz)	RB Size	RB Offset	QPSK						16QAM						
			L-CH 39700	M-CH 40160	M-CH 40620	M-CH 41080	H-CH 41540	3GPP MPR (dB)	L-CH 39700	M-CH 40160	M-CH 40620	M-CH 41080	H-CH 41540	3GPP MPR (dB)	
			2501.0 MHz	2547.0 MHz	2593.0 MHz	2639.0 MHz	2685.0 MHz		2501.0 MHz	2547.0 MHz	2593.0 MHz	2639.0 MHz	2685.0 MHz		
10	1	0	21.61	22.65	22.68	22.29	21.28	0	20.69	21.73	21.76	21.37	20.36	1	
	1	24	21.56	22.60	22.63	22.24	21.23	0	20.64	21.68	21.71	21.32	20.31	1	
	1	49	21.18	22.22	22.25	21.86	21.16	0	20.26	21.30	21.33	20.94	20.24	1	
	25	0	20.81	21.85	21.88	21.49	20.48	1	19.89	20.93	20.96	20.57	19.56	2	
	25	12	20.84	21.88	21.91	21.52	20.51	1	19.92	20.96	20.94	20.60	19.59	2	
	25	25	20.58	21.62	21.65	21.26	20.25	1	19.66	20.70	20.73	20.34	19.33	2	
50	0	20.76	21.80	21.83	21.44	20.43	1	19.84	20.88	20.91	20.52	19.51	2		
BW (MHz)	RB Size	RB Offset	QPSK						16QAM						
			L-CH 39675	M-CH 40148	M-CH 40620	M-CH 41093	H-CH 41565	3GPP MPR (dB)	L-CH 39675	M-CH 40148	M-CH 40620	M-CH 41093	H-CH 41565	3GPP MPR (dB)	
			2498.5 MHz	2545.8 MHz	2593.0 MHz	2640.3 MHz	2687.5 MHz		2498.5 MHz	2545.8 MHz	2593.0 MHz	2640.3 MHz	2687.5 MHz		
5	1	0	21.55	22.59	22.62	22.23	21.22	0	20.63	21.67	21.70	21.31	20.30	1	
	1	12	21.50	22.54	22.57	22.18	21.17	0	20.58	21.62	21.65	21.26	20.25	1	
	1	24	21.12	22.16	22.19	21.80	21.10	0	20.20	21.24	21.27	20.88	20.18	1	
	12	0	20.75	21.79	21.82	21.43	20.42	1	19.83	20.87	20.90	20.51	19.50	2	
	12	6	20.78	21.82	21.85	21.46	20.45	1	19.86	20.90	20.88	20.54	19.53	2	
	12	13	20.52	21.56	21.59	21.20	20.19	1	19.60	20.64	20.67	20.28	19.27	2	
25	0	20.70	21.74	21.77	21.38	20.37	1	19.78	20.82	20.85	20.46	19.45	2		

# FCC SAR Test Report

## <QCNA364A>

### <WLAN 2.4G>

Mode	802.11b		
Channel / Frequency (MHz)	1 (2412)	6 (2437)	11 (2462)
Average Power (Ant-0)	19.78	20.32	19.98
Average Power (Ant-1)	19.63	20.24	19.81
Average Power (Ant-0 + Ant-1)	22.95	23.31	22.94

### <WLAN 5.3G>

Mode	802.11n (HT40)	
Channel / Frequency (MHz)	54 (5270)	62 (5310)
Average Power (Ant-0)	18.88	16.84
Average Power (Ant-1)	18.73	16.87
Average Power (Ant-0 + Ant-1)	21.85	19.91

### <WLAN 5.6G>

Mode	802.11n (HT40)					
Channel / Frequency (MHz)	102 (5510)	110 (5550)	118 (5590)	126 (5630)	134 (5670)	142 (5710)
Average Power (Ant-0)	16.91	18.92	18.88	18.82	18.97	18.92
Average Power (Ant-1)	16.86	18.79	18.75	18.89	18.91	18.76
Average Power (Ant-0 + Ant-1)	19.97	21.91	21.75	21.81	21.93	21.88

### <WLAN 5.8G>

Mode	802.11n (HT40)	
Channel / Frequency (MHz)	151 (5755)	159 (5795)
Average Power (Ant-0)	14.35	18.95
Average Power (Ant-1)	14.35	18.86
Average Power (Ant-0 + Ant-1)	17.47	21.94

### <Bluetooth>

Mode	Bluetooth		
Channel / Frequency (MHz)	0 (2402)	39 (2441)	78 (2480)
Average Power	4.31	5.10	5.52

Mode	Bluetooth LE		
Channel / Frequency (MHz)	0 (2402)	19 (2440)	39 (2480)
Average Power	1.52	1.85	2.03

## 4.7 SAR Testing Results

### 4.7.1 SAR Test Reduction Considerations

#### <KDB 447498 D01, General RF Exposure Guidance>

Testing of other required channels within the operating mode of a frequency band is not required when the reported SAR for the mid-band or highest output power channel is:

- (1)  $\leq 0.8$  W/kg or 2.0 W/kg, for 1-g or 10-g respectively, when the transmission band is  $\leq 100$  MHz
- (2)  $\leq 0.6$  W/kg or 1.5 W/kg, for 1-g or 10-g respectively, when the transmission band is between 100 MHz and 200 MHz
- (3)  $\leq 0.4$  W/kg or 1.0 W/kg, for 1-g or 10-g respectively, when the transmission band is  $\geq 200$  MHz

#### <KDB 941225 D01, 3G SAR Measurement Procedures>

The mode tested for SAR is referred to as the primary mode. The equivalent modes considered for SAR test reduction are denoted as secondary modes. Both primary and secondary modes must be in the same frequency band. When the maximum output power and tune-up tolerance specified for production units in a secondary mode is  $\leq 1/4$  dB higher than the primary mode or when the highest reported SAR of the primary mode is scaled by the ratio of specified maximum output power and tune-up tolerance of secondary to primary mode and the adjusted SAR is  $\leq 1.2$  W/kg, SAR measurement is not required for the secondary mode.

#### <KDB 941225 D05, SAR Evaluation Considerations for LTE Devices>

##### (1) QPSK with 1 RB and 50% RB allocation

Start with the largest channel bandwidth and measure SAR, using the RB offset and required test channel combination with the highest maximum output power among RB offsets at the upper edge, middle and lower edge of each required test channel. When the reported SAR is  $\leq 0.8$  W/kg, testing of the remaining RB offset configurations and required test channels is not required; otherwise, SAR is required for the remaining required test channels and only for the RB offset configuration with the highest output power for that channel. When the reported SAR of a required test channel is  $> 1.45$  W/kg, SAR is required for all three RB offset configurations for that required test channel.

##### (2) QPSK with 100% RB allocation

SAR is not required when the highest maximum output power for 100% RB allocation is less than the highest maximum output power in 50% and 1 RB allocations and the highest reported SAR for 1 RB and 50% RB allocation are  $\leq 0.8$  W/kg. Otherwise, SAR is measured for the highest output power channel; and if the reported SAR is  $> 1.45$  W/kg, the remaining required test channels must also be tested.

##### (3) Higher order modulations

SAR is required only when the highest maximum output power for the configuration in the higher order modulation is  $> 1/2$  dB higher than the same configuration in QPSK or when the reported SAR for the QPSK configuration is  $> 1.45$  W/kg.

##### (4) Other channel bandwidth

SAR is required when the highest maximum output power of the smaller channel bandwidth is  $> 1/2$  dB higher than the equivalent channel configurations in the largest channel bandwidth configuration or the reported SAR of a configuration for the largest channel bandwidth is  $> 1.45$  W/kg.

### <KDB 248227 D01, SAR Guidance for Wi-Fi Transmitters>

- (1) For handsets operating next to ear, hotspot mode or mini-tablet configurations, the initial test position procedures were applied. The test position with the highest extrapolated peak SAR will be used as the initial test position. When the reported SAR of initial test position is  $\leq 0.4$  W/kg, SAR testing for remaining test positions is not required. Otherwise, SAR is evaluated at the subsequent highest peak SAR positions until the reported SAR result is  $\leq 0.8$  W/kg or all test positions are measured.
- (2) For WLAN 2.4 GHz, the highest measured maximum output power channel for DSSS was selected for SAR measurement. When the reported SAR is  $\leq 0.8$  W/kg, no further SAR testing is required. Otherwise, SAR is evaluated at the next highest measured output power channel. When any reported SAR is  $> 1.2$  W/kg, SAR is required for the third channel. For OFDM modes (802.11g/n), SAR is not required when the highest reported SAR for DSSS is adjusted by the ratio of OFDM to DSSS specified maximum output power and it is  $\leq 1.2$  W/kg.
- (3) For WLAN 5 GHz, the initial test configuration was selected according to the transmission mode with the highest maximum output power. When the reported SAR of initial test configuration is  $> 0.8$  W/kg, SAR is required for the subsequent highest measured output power channel until the reported SAR result is  $\leq 1.2$  W/kg or all required channels are measured. For other transmission modes, SAR is not required when the highest reported SAR for initial test configuration is adjusted by the ratio of subsequent test configuration to initial test configuration specified maximum output power and it is  $\leq 1.2$  W/kg.
- (4) For WLAN MIMO mode, the power-based standalone SAR test exclusion or the sum of SAR provision in KDB 447498 to determine simultaneous transmission SAR test exclusion should be applied. Otherwise, SAR for MIMO mode will be measured with all applicable antennas transmitting simultaneously at the specified maximum output power of MIMO operation.

# FCC SAR Test Report

## 4.7.2 SAR Results for Extremity Exposure Condition (Test Separation Distance is 0 mm)

Plot No.	Band	Mode	Test Position	Ch.	Max. Tune-up Power (dBm)	Measured Conducted Power (dBm)	Scaling Factor	Power Drift (dB)	Measured SAR-10g (W/kg)	Scaled SAR-10g (W/kg)
01	WCDMA II	RMC12.2K	Rear Face	9400	24.0	22.87	1.30	0.01	0.561	0.73
	WCDMA II	RMC12.2K	Left Side	9400	24.0	22.87	1.30	-0.17	0.736	<b>0.95</b>
	WCDMA II	RMC12.2K	Top Side	9400	24.0	22.87	1.30	0.08	0.157	0.20
02	WCDMA IV	RMC12.2K	Rear Face	1312	24.0	22.99	1.26	0.03	0.559	0.71
	WCDMA IV	RMC12.2K	Left Side	1312	24.0	22.99	1.26	-0.16	0.646	<b>0.82</b>
	WCDMA IV	RMC12.2K	Top Side	1312	24.0	22.99	1.26	0.13	0.125	0.16
03	WCDMA V	RMC12.2K	Rear Face	4233	24.0	22.86	1.30	0.05	0.501	0.65
	WCDMA V	RMC12.2K	Left Side	4233	24.0	22.86	1.30	-0.15	0.516	<b>0.67</b>
	WCDMA V	RMC12.2K	Top Side	4233	24.0	22.86	1.30	-0.11	0.056	0.07

Plot No.	Band	Mode	Test Position	Ch.	RB#	RB Offset	Max. Tune-up Power (dBm)	Measured Conducted Power (dBm)	Scaling Factor	Power Drift (dB)	Measured SAR-10g (W/kg)	Scaled SAR-10g (W/kg)
04	LTE 2	QPSK20M	Rear Face	18900	1	0	24.0	23.01	1.26	0.05	0.592	0.74
	LTE 2	QPSK20M	Left Side	18900	1	0	24.0	23.01	1.26	-0.15	0.822	<b>1.03</b>
	LTE 2	QPSK20M	Top Side	18900	1	0	24.0	23.01	1.26	-0.11	0.193	0.24
	LTE 2	QPSK20M	Rear Face	18900	50	0	23.0	22.04	1.25	-0.17	0.485	0.60
	LTE 2	QPSK20M	Left Side	18900	50	0	23.0	22.04	1.25	0.02	0.659	0.82
	LTE 2	QPSK20M	Top Side	18900	50	0	23.0	22.04	1.25	0.01	0.151	0.19
05	LTE 4	QPSK20M	Rear Face	20175	1	0	24.0	23.23	1.19	0.08	0.675	0.81
	LTE 4	QPSK20M	Left Side	20175	1	0	24.0	23.23	1.19	-0.12	0.746	<b>0.89</b>
	LTE 4	QPSK20M	Top Side	20175	1	0	24.0	23.23	1.19	-0.11	0.133	0.16
	LTE 4	QPSK20M	Rear Face	20175	50	0	23.0	22.18	1.21	0.15	0.533	0.64
	LTE 4	QPSK20M	Left Side	20175	50	0	23.0	22.18	1.21	0.02	0.545	0.66
	LTE 4	QPSK20M	Top Side	20175	50	0	23.0	22.18	1.21	0.07	0.115	0.14
06	LTE 5	QPSK10M	Rear Face	20600	1	0	24.0	22.91	1.29	0.08	0.509	0.65
	LTE 5	QPSK10M	Left Side	20600	1	0	24.0	22.91	1.29	-0.12	0.553	<b>0.71</b>
	LTE 5	QPSK10M	Top Side	20600	1	0	24.0	22.91	1.29	-0.11	0.079	0.10
	LTE 5	QPSK10M	Rear Face	20600	25	12	23.0	21.87	1.30	0.05	0.423	0.55
	LTE 5	QPSK10M	Left Side	20600	25	12	23.0	21.87	1.30	0.11	0.453	0.59
	LTE 5	QPSK10M	Top Side	20600	25	12	23.0	21.87	1.30	-0.07	0.055	0.07
07	LTE 7	QPSK20M	Rear Face	21100	1	0	23.0	22.88	1.03	0.15	0.403	0.41
	LTE 7	QPSK20M	Left Side	21100	1	0	23.0	22.88	1.03	-0.18	1.11	<b>1.14</b>
	LTE 7	QPSK20M	Top Side	21100	1	0	23.0	22.88	1.03	-0.17	0.152	0.16
	LTE 7	QPSK20M	Rear Face	21100	50	0	22.0	21.97	1.01	0.05	0.348	0.35
	LTE 7	QPSK20M	Left Side	21100	50	0	22.0	21.97	1.01	0.06	1.02	1.03
	LTE 7	QPSK20M	Top Side	21100	50	0	22.0	21.97	1.01	0.02	0.120	0.12
	LTE 7	QPSK20M	Left Side	20850	1	0	23.0	22.81	1.04	0.14	1.05	1.10
08	LTE 12	QPSK10M	Rear Face	23095	1	0	24.0	23.37	1.16	0.12	0.257	0.30
	LTE 12	QPSK10M	Left Side	23095	1	0	24.0	23.37	1.16	-0.13	0.357	<b>0.41</b>
	LTE 12	QPSK10M	Top Side	23095	1	0	24.0	23.37	1.16	-0.15	0.082	0.09
	LTE 12	QPSK10M	Rear Face	23095	25	0	23.0	22.17	1.21	-0.17	0.198	0.24
	LTE 12	QPSK10M	Left Side	23095	25	0	23.0	22.17	1.21	0.11	0.288	0.35
	LTE 12	QPSK10M	Top Side	23095	25	0	23.0	22.17	1.21	0.05	0.061	0.07
09	LTE 13	QPSK10M	Rear Face	23230	1	0	24.0	22.98	1.26	0.08	0.193	0.24
	LTE 13	QPSK10M	Left Side	23230	1	0	24.0	22.98	1.26	-0.16	0.255	<b>0.32</b>
	LTE 13	QPSK10M	Top Side	23230	1	0	24.0	22.98	1.26	-0.01	0.058	0.07
	LTE 13	QPSK10M	Rear Face	23230	25	0	23.0	21.93	1.28	-0.05	0.141	0.18
	LTE 13	QPSK10M	Left Side	23230	25	0	23.0	21.93	1.28	-0.08	0.206	0.26
	LTE 13	QPSK10M	Top Side	23230	25	0	23.0	21.93	1.28	0.15	0.043	0.06
10	LTE 25	QPSK20M	Rear Face	26590	1	0	24.0	23.17	1.21	0.11	0.536	0.65
	LTE 25	QPSK20M	Left Side	26590	1	0	24.0	23.17	1.21	-0.18	0.746	<b>0.90</b>
	LTE 25	QPSK20M	Top Side	26590	1	0	24.0	23.17	1.21	-0.11	0.157	0.19
	LTE 25	QPSK20M	Rear Face	26590	50	0	23.0	22.13	1.22	-0.05	0.427	0.52
	LTE 25	QPSK20M	Left Side	26590	50	0	23.0	22.13	1.22	-0.07	0.379	0.46
	LTE 25	QPSK20M	Top Side	26590	50	0	23.0	22.13	1.22	-0.13	0.125	0.15

# FCC SAR Test Report

Plot No.	Band	Mode	Test Position	Ch.	RB#	RB Offset	Max. Tune-up Power (dBm)	Measured Conducted Power (dBm)	Scaling Factor	Power Drift (dB)	Measured SAR-10g (W/kg)	Scaled SAR-10g (W/kg)
11	LTE 26	QPSK15M	Rear Face	26965	1	0	24.0	23.04	1.25	0.01	0.398	0.50
	LTE 26	QPSK15M	Left Side	26965	1	0	24.0	23.04	1.25	-0.15	0.467	<b>0.58</b>
	LTE 26	QPSK15M	Top Side	26965	1	0	24.0	23.04	1.25	0.07	0.091	0.11
	LTE 26	QPSK15M	Rear Face	26965	36	0	23.0	22.08	1.24	-0.11	0.329	0.41
	LTE 26	QPSK15M	Left Side	26965	36	0	23.0	22.08	1.24	-0.15	0.451	0.56
	LTE 26	QPSK15M	Top Side	26965	36	0	23.0	22.08	1.24	0.08	0.067	0.08
12	LTE 30	QPSK10M	Rear Face	27710	1	0	23.0	21.85	1.30	0.15	0.196	0.26
	LTE 30	QPSK10M	Left Side	27710	1	0	23.0	21.85	1.30	-0.17	0.459	<b>0.60</b>
	LTE 30	QPSK10M	Top Side	27710	1	0	23.0	21.85	1.30	-0.11	0.122	0.16
	LTE 30	QPSK10M	Rear Face	27710	25	0	22.0	20.63	1.37	-0.07	0.151	0.21
	LTE 30	QPSK10M	Left Side	27710	25	0	22.0	20.63	1.37	0.11	0.363	0.50
	LTE 30	QPSK10M	Top Side	27710	25	0	22.0	20.63	1.37	0.02	0.097	0.13
13	LTE 41	QPSK20M	Rear Face	40620	1	0	23.0	22.75	1.06	0.05	0.277	0.29
	LTE 41	QPSK20M	Left Side	40620	1	0	23.0	22.75	1.06	-0.1	0.837	<b>0.89</b>
	LTE 41	QPSK20M	Top Side	40620	1	0	23.0	22.75	1.06	-0.11	0.156	0.17
	LTE 41	QPSK20M	Rear Face	40620	50	25	22.0	21.98	1.00	0.07	0.275	0.28
	LTE 41	QPSK20M	Left Side	40620	50	25	22.0	21.98	1.00	0.15	0.833	0.84
	LTE 41	QPSK20M	Top Side	40620	50	25	22.0	21.98	1.00	0.16	0.153	0.15

## <QCNA364A>

Plot No.	Band	Mode	Test Position	Ch.	Tx Antenna	Max. Tune-up Power (dBm)	Measured Conducted Power (dBm)	Scaling Factor	Power Drift (dB)	Measured SAR-10g (W/kg)	Scaled SAR-10g (W/kg)	
14	2.4G WLAN	802.11b	Rear Face	6	0	20.5	20.32	1.04	0.1	0.408	0.43	
	2.4G WLAN	802.11b	Right Side	6	0	20.5	20.32	1.04	-0.14	1	1.04	
	2.4G WLAN	802.11b	Top Side	6	0	20.5	20.32	1.04	-0.13	0.078	0.08	
	2.4G WLAN	802.11b	Rear Face	6	1	20.5	20.24	1.06	0.04	0.026	0.03	
	2.4G WLAN	802.11b	Right Side	6	1	20.5	20.24	1.06	0.02	0.043	0.05	
	2.4G WLAN	802.11b	Rear Face	6	0+1	23.5	23.31	1.04	-0.16	0.522	0.55	
	2.4G WLAN	802.11b	Right Side	6	0+1	23.5	23.31	1.04	-0.09	1.03	<b>1.08</b>	
	2.4G WLAN	802.11b	Top Side	6	0+1	23.5	23.31	1.04	-0.07	0.072	0.08	
	2.4G WLAN	802.11b	Right Side	1	0+1	23.0	22.95	1.01	0.12	0.874	0.88	
	2.4G WLAN	802.11b	Right Side	11	0+1	23.0	22.94	1.01	-0.05	0.973	0.99	
15	5.3G WLAN	802.11n HT40	Rear Face	54	0	19.0	18.88	1.03	0.01	0.158	0.16	
	5.3G WLAN	802.11n HT40	Right Side	54	0	19.0	18.88	1.03	0.14	0.32	0.33	
	5.3G WLAN	802.11n HT40	Top Side	54	0	19.0	18.88	1.03	-0.06	0.242	0.25	
	5.3G WLAN	802.11n HT40	Rear Face	54	1	19.0	18.73	1.06	-0.1	0.096	0.10	
	5.3G WLAN	802.11n HT40	Right Side	54	1	19.0	18.73	1.06	0.18	0.139	0.15	
	5.3G WLAN	802.11n HT40	Rear Face	54	0+1	22.0	21.85	1.04	-0.08	0.178	0.18	
	5.3G WLAN	802.11n HT40	Right Side	54	0+1	22.0	21.85	1.04	0.04	0.324	<b>0.34</b>	
	5.3G WLAN	802.11n HT40	Top Side	54	0+1	22.0	21.85	1.04	0.06	0.256	0.26	
	16	5.6G WLAN	802.11n HT40	Rear Face	134	0	19.0	18.97	1.01	0.03	0.124	0.12
		5.6G WLAN	802.11n HT40	Right Side	134	0	19.0	18.97	1.01	0.05	0.308	0.31
5.6G WLAN		802.11n HT40	Top Side	134	0	19.0	18.97	1.01	-0.05	0.104	0.10	
5.6G WLAN		802.11n HT40	Rear Face	134	1	19.0	18.91	1.02	0.03	0.071	0.07	
5.6G WLAN		802.11n HT40	Right Side	134	1	19.0	18.91	1.02	0.16	0.1	0.10	
5.6G WLAN		802.11n HT40	Rear Face	134	0+1	22.0	21.93	1.02	-0.14	0.17	0.17	
5.6G WLAN		802.11n HT40	Right Side	134	0+1	22.0	21.93	1.02	-0.03	0.415	0.42	
5.6G WLAN		802.11n HT40	Top Side	134	0+1	22.0	21.93	1.02	0.08	0.53	<b>0.54</b>	
17		5.8G WLAN	802.11n HT40	Rear Face	159	0	19.0	18.95	1.01	-0.05	0.12	0.12
		5.8G WLAN	802.11n HT40	Right Side	159	0	19.0	18.95	1.01	0.01	0.27	0.27
	5.8G WLAN	802.11n HT40	Top Side	159	0	19.0	18.95	1.01	0.11	0.406	0.41	
	5.8G WLAN	802.11n HT40	Rear Face	159	1	19.0	18.86	1.03	0.04	0.069	0.07	
	5.8G WLAN	802.11n HT40	Right Side	159	1	19.0	18.86	1.03	0.1	0.099	0.10	
	5.8G WLAN	802.11n HT40	Rear Face	159	0+1	22.0	21.94	1.01	-0.11	0.129	0.13	
	5.8G WLAN	802.11n HT40	Right Side	159	0+1	22.0	21.94	1.01	-0.06	0.303	0.31	
	5.8G WLAN	802.11n HT40	Top Side	159	0+1	22.0	21.94	1.01	0.07	0.419	<b>0.42</b>	

# FCC SAR Test Report

Plot No.	Band	Test Position	Ch.	Max. Tune-up Power (dBm)	Measured Conducted Power (dBm)	Scaling Factor	Power Drift (dB)	Measured SAR-10g (W/kg)	Scaled SAR-10g (W/kg)
18	Bluetooth	Rear Face	39	7.0	5.10	1.55	-0.14	0.011	<b>0.02</b>

### 4.7.3 SAR Measurement Variability

According to KDB 865664 D01, SAR measurement variability was assessed for each frequency band, which is determined by the SAR probe calibration point and tissue-equivalent medium used for the device measurements. When both head and body tissue-equivalent media are required for SAR measurements in a frequency band, the variability measurement procedures should be applied to the tissue medium with the highest measured SAR, using the highest measured SAR configuration for that tissue-equivalent medium. Alternatively, if the highest measured SAR for both head and body tissue-equivalent media are  $\leq 1.45$  W/kg and the ratio of these highest SAR values, i.e., largest divided by smallest value, is  $\leq 1.10$ , the highest SAR configuration for either head or body tissue-equivalent medium may be used to perform the repeated measurement. These additional measurements are repeated after the completion of all measurements requiring the same head or body tissue-equivalent medium in a frequency band. The test device should be returned to ambient conditions (normal room temperature) with the battery fully charged before it is re-mounted on the device holder for the repeated measurement(s) to minimize any unexpected variations in the repeated results.

Since all the measured SAR are less than 0.8 W/kg, the repeated measurement is not required.

### 4.7.4 Simultaneous Multi-band Transmission Evaluation

#### <Possibilities of Simultaneous Transmission>

The simultaneous transmission possibilities for this device are listed as below.

Simultaneous TX Combination	Capable Transmit Configurations	Extremity Exposure Condition
1	WCDMA + WiFi 2.4GHz	Yes
2	WCDMA + WiFi 5GHz	Yes
3	WCDMA + BT	Yes
4	LTE + WiFi 2.4GHz	Yes
5	LTE + WiFi 5GHz	Yes
6	LTE + BT	Yes
7	WLAN 2.4G + BT (WiFi and BT can transmit simultaneously in the different antenna.)	Yes
8	WLAN 5G + BT (WiFi and BT can transmit simultaneously in the different antenna )	Yes

**Note :** The WLAN 2.4G and WLAN 5G cannot transmit simultaneously.



# FCC SAR Test Report

## <Estimated SAR Calculation>

According to KDB 447498 D01, when standalone SAR test exclusion applies to an antenna that transmits simultaneously with other antennas, the standalone SAR was estimated according to following formula to result in substantially conservative SAR values of  $\leq 0.4$  W/kg to determine simultaneous transmission SAR test exclusion.

$$\text{Estimated SAR} = \frac{\text{Max. Tune up Power}_{(mW)}}{\text{Min. Test Separation Distance}_{(mm)}} \times \frac{\sqrt{f_{(GHz)}}}{7.5}$$

If the minimum test separation distance is  $< 5$  mm, a distance of 5 mm is used for estimated SAR calculation. When the test separation distance is  $> 50$  mm, the 0.4 W/kg is used for SAR-1g.

Mode / Band	Frequency (GHz)	Max. Tune-up Power (dBm)	Test Position	Separation Distance (mm)	Estimated 10g SAR (W/kg)
WCDMA II	1.9076	24.0	Extremity	0	1
WCDMA IV	1.7526	24.0	Extremity	0	1
WCDMA V	0.8466	24.0	Extremity	0	1
LTE 2	1.9093	24.0	Extremity	0	1
LTE 4	1.7543	24.0	Extremity	0	1
LTE 5	0.8483	24.0	Extremity	0	1
LTE 7	2.5675	23.0	Extremity	0	1
LTE 12	0.7153	24.0	Extremity	0	1
LTE 13	0.7845	24.0	Extremity	0	1
LTE 25	1.9143	24.0	Extremity	0	1
LTE 26	0.8483	24.0	Extremity	0	1
LTE 30	2.3125	23.0	Extremity	0	1
LTE 41	2.6875	23.0	Extremity	0	1

## <QC NFA364A>

Mode / Band	Frequency (GHz)	Max. Tune-up Power (dBm)	Test Position	Separation Distance (mm)	Estimated 10g SAR (W/kg)
WLAN (DTS)	2.462	23.5	Extremity	0	1
WLAN (NII)	5.24	18.0	Extremity	0	1
WLAN (NII)	5.32	22.0	Extremity	0	1
WLAN (NII)	5.7	22.0	Extremity	0	1
WLAN (NII)	5.825	22.0	Extremity	0	1
BT (DSS)	2.48	7.0	Extremity	0	0.08

### Note:

1. The separation distance is determined from the outer housing of the EUT to the user.
2. When standalone SAR testing is not required, an estimated SAR can be applied to determine simultaneous transmission SAR test exclusion.

# FCC SAR Test Report

## <SAR Summation Analysis>

Simultaneous transmission SAR test exclusion is determined for each operating configuration and exposure condition according to the reported standalone SAR of each applicable simultaneous transmitting antenna. When the sum of SAR<sub>1g</sub> of all simultaneously transmitting antennas in an operating mode and exposure condition combination is within the SAR limit (SAR<sub>1g</sub> 1.6 W/kg), the simultaneous transmission SAR is not required. When the sum of SAR<sub>1g</sub> is greater than the SAR limit (SAR<sub>1g</sub> 1.6 W/kg), SAR test exclusion is determined by the SPLSR.

No.	Conditions (SAR1 + SAR2)	Exposure Condition	Test Position	Max. SAR1	Max. SAR2	SAR Summation	SPLSR Analysis
1	WCDMA II + WLAN (DTS)	Extremity	Rear Face	0.73	0.55	1.28	Σ SAR < 4.0, Not required
			Left Side	0.95	1.00	1.95	Σ SAR < 4.0, Not required
			Right Side	1.00	1.08	2.08	Σ SAR < 4.0, Not required
			Top Side	0.20	0.08	0.28	Σ SAR < 4.0, Not required
			Bottom Side	1.00	1.00	2.00	Σ SAR < 4.0, Not required
2	WCDMA II + WLAN (NII)	Extremity	Rear Face	0.73	0.18	0.91	Σ SAR < 4.0, Not required
			Left Side	0.95	1.00	1.95	Σ SAR < 4.0, Not required
			Right Side	1.00	0.42	1.42	Σ SAR < 4.0, Not required
			Top Side	0.20	0.54	0.74	Σ SAR < 4.0, Not required
			Bottom Side	1.00	1.00	2.00	Σ SAR < 4.0, Not required
3	WCDMA II + BT (DSS)	Extremity	Rear Face	0.73	0.02	0.75	Σ SAR < 4.0, Not required
			Left Side	0.95	0.08	1.03	Σ SAR < 4.0, Not required
			Right Side	1.00	0.08	1.08	Σ SAR < 4.0, Not required
			Top Side	0.20	0.08	0.28	Σ SAR < 4.0, Not required
			Bottom Side	1.00	0.08	1.08	Σ SAR < 4.0, Not required

# FCC SAR Test Report

No.	Conditions (SAR1 + SAR2)	Exposure Condition	Test Position	Max. SAR1	Max. SAR2	SAR Summation	SPLSR Analysis
4	WCDMA IV + WLAN (DTS)	Extremity	Rear Face	0.71	0.55	1.26	$\Sigma$ SAR < 4.0, Not required
			Left Side	0.82	1.00	1.82	$\Sigma$ SAR < 4.0, Not required
			Right Side	1.00	1.08	2.08	$\Sigma$ SAR < 4.0, Not required
			Top Side	0.16	0.08	0.24	$\Sigma$ SAR < 4.0, Not required
			Bottom Side	1.00	1.00	2.00	$\Sigma$ SAR < 4.0, Not required
5	WCDMA IV + WLAN (NII)	Extremity	Rear Face	0.71	0.18	0.89	$\Sigma$ SAR < 4.0, Not required
			Left Side	0.82	1.00	1.82	$\Sigma$ SAR < 4.0, Not required
			Right Side	1.00	0.42	1.42	$\Sigma$ SAR < 4.0, Not required
			Top Side	0.16	0.54	0.70	$\Sigma$ SAR < 4.0, Not required
			Bottom Side	1.00	1.00	2.00	$\Sigma$ SAR < 4.0, Not required
6	WCDMA IV + BT (DSS)	Extremity	Rear Face	0.71	0.02	0.73	$\Sigma$ SAR < 4.0, Not required
			Left Side	0.82	0.08	0.90	$\Sigma$ SAR < 4.0, Not required
			Right Side	1.00	0.08	1.08	$\Sigma$ SAR < 4.0, Not required
			Top Side	0.16	0.08	0.24	$\Sigma$ SAR < 4.0, Not required
			Bottom Side	1.00	0.08	1.08	$\Sigma$ SAR < 4.0, Not required

No.	Conditions (SAR1 + SAR2)	Exposure Condition	Test Position	Max. SAR1	Max. SAR2	SAR Summation	SPLSR Analysis
7	WCDMA V + WLAN (DTS)	Extremity	Rear Face	0.65	0.55	1.20	$\Sigma$ SAR < 4.0, Not required
			Left Side	0.67	1.00	1.67	$\Sigma$ SAR < 4.0, Not required
			Right Side	1.00	1.08	2.08	$\Sigma$ SAR < 4.0, Not required
			Top Side	0.07	0.08	0.15	$\Sigma$ SAR < 4.0, Not required
			Bottom Side	1.00	1.00	2.00	$\Sigma$ SAR < 4.0, Not required
8	WCDMA V + WLAN (NII)	Extremity	Rear Face	0.65	0.18	0.83	$\Sigma$ SAR < 4.0, Not required
			Left Side	0.67	1.00	1.67	$\Sigma$ SAR < 4.0, Not required
			Right Side	1.00	0.42	1.42	$\Sigma$ SAR < 4.0, Not required
			Top Side	0.07	0.54	0.61	$\Sigma$ SAR < 4.0, Not required
			Bottom Side	1.00	1.00	2.00	$\Sigma$ SAR < 4.0, Not required
9	WCDMA V + BT (DSS)	Extremity	Rear Face	0.65	0.02	0.67	$\Sigma$ SAR < 4.0, Not required
			Left Side	0.67	0.08	0.75	$\Sigma$ SAR < 4.0, Not required
			Right Side	1.00	0.08	1.08	$\Sigma$ SAR < 4.0, Not required
			Top Side	0.07	0.08	0.15	$\Sigma$ SAR < 4.0, Not required
			Bottom Side	1.00	0.08	1.08	$\Sigma$ SAR < 4.0, Not required

# FCC SAR Test Report

No.	Conditions (SAR1 + SAR2)	Exposure Condition	Test Position	Max. SAR1	Max. SAR2	SAR Summation	SPLSR Analysis
10	LTE 2 + WLAN (DTS)	Extremity	Rear Face	0.74	0.55	1.29	$\Sigma$ SAR < 4.0, Not required
			Left Side	1.03	1.00	2.03	$\Sigma$ SAR < 4.0, Not required
			Right Side	1.00	1.08	2.08	$\Sigma$ SAR < 4.0, Not required
			Top Side	0.24	0.08	0.32	$\Sigma$ SAR < 4.0, Not required
			Bottom Side	1.00	1.00	2.00	$\Sigma$ SAR < 4.0, Not required
11	LTE 2 + WLAN (NII)	Extremity	Rear Face	0.74	0.18	0.92	$\Sigma$ SAR < 4.0, Not required
			Left Side	1.03	1.00	2.03	$\Sigma$ SAR < 4.0, Not required
			Right Side	1.00	0.42	1.42	$\Sigma$ SAR < 4.0, Not required
			Top Side	0.24	0.54	0.78	$\Sigma$ SAR < 4.0, Not required
			Bottom Side	1.00	1.00	2.00	$\Sigma$ SAR < 4.0, Not required
12	LTE 2 + BT (DSS)	Extremity	Rear Face	0.74	0.02	0.76	$\Sigma$ SAR < 4.0, Not required
			Left Side	1.03	0.08	1.11	$\Sigma$ SAR < 4.0, Not required
			Right Side	1.00	0.08	1.08	$\Sigma$ SAR < 4.0, Not required
			Top Side	0.24	0.08	0.32	$\Sigma$ SAR < 4.0, Not required
			Bottom Side	1.00	0.08	1.08	$\Sigma$ SAR < 4.0, Not required

No.	Conditions (SAR1 + SAR2)	Exposure Condition	Test Position	Max. SAR1	Max. SAR2	SAR Summation	SPLSR Analysis
13	LTE 4 + WLAN (DTS)	Extremity	Rear Face	0.81	0.55	1.36	$\Sigma$ SAR < 4.0, Not required
			Left Side	0.89	1.00	1.89	$\Sigma$ SAR < 4.0, Not required
			Right Side	1.00	1.08	2.08	$\Sigma$ SAR < 4.0, Not required
			Top Side	0.16	0.08	0.24	$\Sigma$ SAR < 4.0, Not required
			Bottom Side	1.00	1.00	2.00	$\Sigma$ SAR < 4.0, Not required
14	LTE 4 + WLAN (NII)	Extremity	Rear Face	0.81	0.18	0.99	$\Sigma$ SAR < 4.0, Not required
			Left Side	0.89	1.00	1.89	$\Sigma$ SAR < 4.0, Not required
			Right Side	1.00	0.42	1.42	$\Sigma$ SAR < 4.0, Not required
			Top Side	0.16	0.54	0.70	$\Sigma$ SAR < 4.0, Not required
			Bottom Side	1.00	1.00	2.00	$\Sigma$ SAR < 4.0, Not required
15	LTE 4 + BT (DSS)	Extremity	Rear Face	0.81	0.02	0.83	$\Sigma$ SAR < 4.0, Not required
			Left Side	0.89	0.08	0.97	$\Sigma$ SAR < 4.0, Not required
			Right Side	1.00	0.08	1.08	$\Sigma$ SAR < 4.0, Not required
			Top Side	0.16	0.08	0.24	$\Sigma$ SAR < 4.0, Not required
			Bottom Side	1.00	0.08	1.08	$\Sigma$ SAR < 4.0, Not required

# FCC SAR Test Report

No.	Conditions (SAR1 + SAR2)	Exposure Condition	Test Position	Max. SAR1	Max. SAR2	SAR Summation	SPLSR Analysis
16	LTE 5 + WLAN (DTS)	Extremity	Rear Face	0.65	0.55	1.20	$\Sigma$ SAR < 4.0, Not required
			Left Side	0.71	1.00	1.71	$\Sigma$ SAR < 4.0, Not required
			Right Side	1.00	1.08	2.08	$\Sigma$ SAR < 4.0, Not required
			Top Side	0.10	0.08	0.18	$\Sigma$ SAR < 4.0, Not required
			Bottom Side	1.00	1.00	2.00	$\Sigma$ SAR < 4.0, Not required
17	LTE 5 + WLAN (NII)	Extremity	Rear Face	0.65	0.18	0.83	$\Sigma$ SAR < 4.0, Not required
			Left Side	0.71	1.00	1.71	$\Sigma$ SAR < 4.0, Not required
			Right Side	1.00	0.42	1.42	$\Sigma$ SAR < 4.0, Not required
			Top Side	0.10	0.54	0.64	$\Sigma$ SAR < 4.0, Not required
			Bottom Side	1.00	1.00	2.00	$\Sigma$ SAR < 4.0, Not required
18	LTE 5 + BT (DSS)	Extremity	Rear Face	0.65	0.02	0.67	$\Sigma$ SAR < 4.0, Not required
			Left Side	0.71	0.08	0.79	$\Sigma$ SAR < 4.0, Not required
			Right Side	1.00	0.08	1.08	$\Sigma$ SAR < 4.0, Not required
			Top Side	0.10	0.08	0.18	$\Sigma$ SAR < 4.0, Not required
			Bottom Side	1.00	0.08	1.08	$\Sigma$ SAR < 4.0, Not required

No.	Conditions (SAR1 + SAR2)	Exposure Condition	Test Position	Max. SAR1	Max. SAR2	SAR Summation	SPLSR Analysis
19	LTE 7 + WLAN (DTS)	Extremity	Rear Face	0.41	0.55	0.96	$\Sigma$ SAR < 4.0, Not required
			Left Side	1.14	1.00	2.14	$\Sigma$ SAR < 4.0, Not required
			Right Side	1.00	1.08	2.08	$\Sigma$ SAR < 4.0, Not required
			Top Side	0.16	0.08	0.24	$\Sigma$ SAR < 4.0, Not required
			Bottom Side	1.00	1.00	2.00	$\Sigma$ SAR < 4.0, Not required
20	LTE 7 + WLAN (NII)	Extremity	Rear Face	0.41	0.18	0.59	$\Sigma$ SAR < 4.0, Not required
			Left Side	1.14	1.00	2.14	$\Sigma$ SAR < 4.0, Not required
			Right Side	1.00	0.42	1.42	$\Sigma$ SAR < 4.0, Not required
			Top Side	0.16	0.54	0.70	$\Sigma$ SAR < 4.0, Not required
			Bottom Side	1.00	1.00	2.00	$\Sigma$ SAR < 4.0, Not required
21	LTE 7 + BT (DSS)	Extremity	Rear Face	0.41	0.02	0.43	$\Sigma$ SAR < 4.0, Not required
			Left Side	1.14	0.08	1.22	$\Sigma$ SAR < 4.0, Not required
			Right Side	1.00	0.08	1.08	$\Sigma$ SAR < 4.0, Not required
			Top Side	0.16	0.08	0.24	$\Sigma$ SAR < 4.0, Not required
			Bottom Side	1.00	0.08	1.08	$\Sigma$ SAR < 4.0, Not required

# FCC SAR Test Report

No.	Conditions (SAR1 + SAR2)	Exposure Condition	Test Position	Max. SAR1	Max. SAR2	SAR Summation	SPLSR Analysis
22	LTE 12 + WLAN (DTS)	Extremity	Rear Face	0.30	0.55	0.85	$\Sigma$ SAR < 4.0, Not required
			Left Side	0.41	1.00	1.41	$\Sigma$ SAR < 4.0, Not required
			Right Side	1.00	1.08	2.08	$\Sigma$ SAR < 4.0, Not required
			Top Side	0.09	0.08	0.17	$\Sigma$ SAR < 4.0, Not required
			Bottom Side	1.00	1.00	2.00	$\Sigma$ SAR < 4.0, Not required
23	LTE 12 + WLAN (NII)	Extremity	Rear Face	0.30	0.18	0.48	$\Sigma$ SAR < 4.0, Not required
			Left Side	0.41	1.00	1.41	$\Sigma$ SAR < 4.0, Not required
			Right Side	1.00	0.42	1.42	$\Sigma$ SAR < 4.0, Not required
			Top Side	0.09	0.54	0.63	$\Sigma$ SAR < 4.0, Not required
			Bottom Side	1.00	1.00	2.00	$\Sigma$ SAR < 4.0, Not required
24	LTE 12 + BT (DSS)	Extremity	Rear Face	0.30	0.02	0.32	$\Sigma$ SAR < 4.0, Not required
			Left Side	0.41	0.08	0.49	$\Sigma$ SAR < 4.0, Not required
			Right Side	1.00	0.08	1.08	$\Sigma$ SAR < 4.0, Not required
			Top Side	0.09	0.08	0.17	$\Sigma$ SAR < 4.0, Not required
			Bottom Side	1.00	0.08	1.08	$\Sigma$ SAR < 4.0, Not required

No.	Conditions (SAR1 + SAR2)	Exposure Condition	Test Position	Max. SAR1	Max. SAR2	SAR Summation	SPLSR Analysis
25	LTE 13 + WLAN (DTS)	Extremity	Rear Face	0.24	0.55	0.79	$\Sigma$ SAR < 4.0, Not required
			Left Side	0.32	1.00	1.32	$\Sigma$ SAR < 4.0, Not required
			Right Side	1.00	1.08	2.08	$\Sigma$ SAR < 4.0, Not required
			Top Side	0.07	0.08	0.15	$\Sigma$ SAR < 4.0, Not required
			Bottom Side	1.00	1.00	2.00	$\Sigma$ SAR < 4.0, Not required
26	LTE 13 + WLAN (NII)	Extremity	Rear Face	0.24	0.18	0.42	$\Sigma$ SAR < 4.0, Not required
			Left Side	0.32	1.00	1.32	$\Sigma$ SAR < 4.0, Not required
			Right Side	1.00	0.42	1.42	$\Sigma$ SAR < 4.0, Not required
			Top Side	0.07	0.54	0.61	$\Sigma$ SAR < 4.0, Not required
			Bottom Side	1.00	1.00	2.00	$\Sigma$ SAR < 4.0, Not required
27	LTE 13 + BT (DSS)	Extremity	Rear Face	0.24	0.02	0.26	$\Sigma$ SAR < 4.0, Not required
			Left Side	0.32	0.08	0.40	$\Sigma$ SAR < 4.0, Not required
			Right Side	1.00	0.08	1.08	$\Sigma$ SAR < 4.0, Not required
			Top Side	0.07	0.08	0.15	$\Sigma$ SAR < 4.0, Not required
			Bottom Side	1.00	0.08	1.08	$\Sigma$ SAR < 4.0, Not required

# FCC SAR Test Report

No.	Conditions (SAR1 + SAR2)	Exposure Condition	Test Position	Max. SAR1	Max. SAR2	SAR Summation	SPLSR Analysis
28	LTE 25 + WLAN (DTS)	Extremity	Rear Face	0.65	0.55	1.20	$\Sigma$ SAR < 4.0, Not required
			Left Side	0.90	1.00	1.90	$\Sigma$ SAR < 4.0, Not required
			Right Side	1.00	1.08	2.08	$\Sigma$ SAR < 4.0, Not required
			Top Side	0.19	0.08	0.27	$\Sigma$ SAR < 4.0, Not required
			Bottom Side	1.00	1.00	2.00	$\Sigma$ SAR < 4.0, Not required
29	LTE 25 + WLAN (NII)	Extremity	Rear Face	0.65	0.18	0.83	$\Sigma$ SAR < 4.0, Not required
			Left Side	0.90	1.00	1.90	$\Sigma$ SAR < 4.0, Not required
			Right Side	1.00	0.42	1.42	$\Sigma$ SAR < 4.0, Not required
			Top Side	0.19	0.54	0.73	$\Sigma$ SAR < 4.0, Not required
			Bottom Side	1.00	1.00	2.00	$\Sigma$ SAR < 4.0, Not required
30	LTE 25 + BT (DSS)	Extremity	Rear Face	0.65	0.02	0.67	$\Sigma$ SAR < 4.0, Not required
			Left Side	0.90	0.08	0.98	$\Sigma$ SAR < 4.0, Not required
			Right Side	1.00	0.08	1.08	$\Sigma$ SAR < 4.0, Not required
			Top Side	0.19	0.08	0.27	$\Sigma$ SAR < 4.0, Not required
			Bottom Side	1.00	0.08	1.08	$\Sigma$ SAR < 4.0, Not required

No.	Conditions (SAR1 + SAR2)	Exposure Condition	Test Position	Max. SAR1	Max. SAR2	SAR Summation	SPLSR Analysis
31	LTE 26 + WLAN (DTS)	Extremity	Rear Face	0.50	0.55	1.05	$\Sigma$ SAR < 4.0, Not required
			Left Side	0.58	1.00	1.58	$\Sigma$ SAR < 4.0, Not required
			Right Side	1.00	1.08	2.08	$\Sigma$ SAR < 4.0, Not required
			Top Side	0.11	0.08	0.19	$\Sigma$ SAR < 4.0, Not required
			Bottom Side	1.00	1.00	2.00	$\Sigma$ SAR < 4.0, Not required
32	LTE 26 + WLAN (NII)	Extremity	Rear Face	0.50	0.18	0.68	$\Sigma$ SAR < 4.0, Not required
			Left Side	0.58	1.00	1.58	$\Sigma$ SAR < 4.0, Not required
			Right Side	1.00	0.42	1.42	$\Sigma$ SAR < 4.0, Not required
			Top Side	0.11	0.54	0.65	$\Sigma$ SAR < 4.0, Not required
			Bottom Side	1.00	1.00	2.00	$\Sigma$ SAR < 4.0, Not required
33	LTE 26 + BT (DSS)	Extremity	Rear Face	0.50	0.02	0.52	$\Sigma$ SAR < 4.0, Not required
			Left Side	0.58	0.08	0.66	$\Sigma$ SAR < 4.0, Not required
			Right Side	1.00	0.08	1.08	$\Sigma$ SAR < 4.0, Not required
			Top Side	0.11	0.08	0.19	$\Sigma$ SAR < 4.0, Not required
			Bottom Side	1.00	0.08	1.08	$\Sigma$ SAR < 4.0, Not required

# FCC SAR Test Report

No.	Conditions (SAR1 + SAR2)	Exposure Condition	Test Position	Max. SAR1	Max. SAR2	SAR Summation	SPLSR Analysis
34	LTE 30 + WLAN (DTS)	Extremity	Rear Face	0.26	0.55	0.81	$\Sigma$ SAR < 4.0, Not required
			Left Side	0.60	1.00	1.60	$\Sigma$ SAR < 4.0, Not required
			Right Side	1.00	1.08	2.08	$\Sigma$ SAR < 4.0, Not required
			Top Side	0.16	0.08	0.24	$\Sigma$ SAR < 4.0, Not required
			Bottom Side	1.00	1.00	2.00	$\Sigma$ SAR < 4.0, Not required
35	LTE 30 + WLAN (NII)	Extremity	Rear Face	0.26	0.18	0.44	$\Sigma$ SAR < 4.0, Not required
			Left Side	0.60	1.00	1.60	$\Sigma$ SAR < 4.0, Not required
			Right Side	1.00	0.42	1.42	$\Sigma$ SAR < 4.0, Not required
			Top Side	0.16	0.54	0.70	$\Sigma$ SAR < 4.0, Not required
			Bottom Side	1.00	1.00	2.00	$\Sigma$ SAR < 4.0, Not required
36	LTE 30 + BT (DSS)	Extremity	Rear Face	0.26	0.02	0.28	$\Sigma$ SAR < 4.0, Not required
			Left Side	0.60	0.08	0.68	$\Sigma$ SAR < 4.0, Not required
			Right Side	1.00	0.08	1.08	$\Sigma$ SAR < 4.0, Not required
			Top Side	0.16	0.08	0.24	$\Sigma$ SAR < 4.0, Not required
			Bottom Side	1.00	0.08	1.08	$\Sigma$ SAR < 4.0, Not required

No.	Conditions (SAR1 + SAR2)	Exposure Condition	Test Position	Max. SAR1	Max. SAR2	SAR Summation	SPLSR Analysis
37	LTE 41 + WLAN (DTS)	Extremity	Rear Face	0.29	0.55	0.84	$\Sigma$ SAR < 4.0, Not required
			Left Side	0.89	1.00	1.89	$\Sigma$ SAR < 4.0, Not required
			Right Side	1.00	1.08	2.08	$\Sigma$ SAR < 4.0, Not required
			Top Side	0.17	0.08	0.25	$\Sigma$ SAR < 4.0, Not required
			Bottom Side	1.00	1.00	2.00	$\Sigma$ SAR < 4.0, Not required
38	LTE 41 + WLAN (NII)	Extremity	Rear Face	0.29	0.18	0.47	$\Sigma$ SAR < 4.0, Not required
			Left Side	0.89	1.00	1.89	$\Sigma$ SAR < 4.0, Not required
			Right Side	1.00	0.42	1.42	$\Sigma$ SAR < 4.0, Not required
			Top Side	0.17	0.54	0.71	$\Sigma$ SAR < 4.0, Not required
			Bottom Side	1.00	1.00	2.00	$\Sigma$ SAR < 4.0, Not required
39	LTE 41 + BT (DSS)	Extremity	Rear Face	0.29	0.02	0.31	$\Sigma$ SAR < 4.0, Not required
			Left Side	0.89	0.08	0.97	$\Sigma$ SAR < 4.0, Not required
			Right Side	1.00	0.08	1.08	$\Sigma$ SAR < 4.0, Not required
			Top Side	0.17	0.08	0.25	$\Sigma$ SAR < 4.0, Not required
			Bottom Side	1.00	0.08	1.08	$\Sigma$ SAR < 4.0, Not required



# FCC SAR Test Report

No.	Conditions (SAR1 + SAR2)	Exposure Condition	Test Position	Max. SAR1	Max. SAR2	SAR Summation	SPLSR Analysis
40	WLAN (DTS) + BT (DSS)	Extremity	Rear Face	0.55	0.02	0.57	$\Sigma$ SAR < 4.0, Not required
			Left Side	1.00	0.08	1.08	$\Sigma$ SAR < 4.0, Not required
			Right Side	1.08	0.08	1.16	$\Sigma$ SAR < 4.0, Not required
			Top Side	0.08	0.08	0.16	$\Sigma$ SAR < 4.0, Not required
			Bottom Side	1.00	0.08	1.08	$\Sigma$ SAR < 4.0, Not required
41	WLAN (NII) + BT (DSS)	Extremity	Rear Face	0.18	0.02	0.20	$\Sigma$ SAR < 4.0, Not required
			Left Side	1.00	0.08	1.08	$\Sigma$ SAR < 4.0, Not required
			Right Side	0.42	0.08	0.50	$\Sigma$ SAR < 4.0, Not required
			Top Side	0.54	0.08	0.62	$\Sigma$ SAR < 4.0, Not required
			Bottom Side	1.00	0.08	1.08	$\Sigma$ SAR < 4.0, Not required

Test Engineer : Eric Wu, and Isaac Liao

## 5. Calibration of Test Equipment

Equipment	Manufacturer	Model	SN	Cal. Date	Cal. Interval
System Validation Dipole	SPEAG	D750V3	1013	Aug. 21, 2017	1 Year
System Validation Dipole	SPEAG	D835V2	4d121	Aug. 21, 2017	1 Year
System Validation Dipole	SPEAG	D1750V2	1055	Aug. 21, 2017	1 Year
System Validation Dipole	SPEAG	D1900V2	5d036	Jan. 23, 2017	1 Year
System Validation Dipole	SPEAG	D2300V2	1004	Jan. 25, 2017	1 Year
System Validation Dipole	SPEAG	D2600V2	1020	Aug. 17, 2017	1 Year
System Validation Dipole	SPEAG	D2450V2	737	Aug. 17, 2017	1 Year
System Validation Dipole	SPEAG	D5GHzV2	1019	Aug. 23, 2017	1 Year
Dosimetric E-Field Probe	SPEAG	EX3DV4	3971	Mar. 24, 2017	1 Year
Dosimetric E-Field Probe	SPEAG	EX3DV4	7375	Dec. 08, 2016	1 Year
Data Acquisition Electronics	SPEAG	DAE4	1431	Mar. 20, 2017	1 Year
Data Acquisition Electronics	SPEAG	DAE3	579	Aug. 17, 2017	1 Year
Spectrum Analyzer	R&S	FSL6	102006	Mar. 27, 2017	1 Year
ENA Series Network Analyzer	Agilent	E5071C	MY46214281	Jun. 09, 2017	1 Year
MXG Analog Signal Generator	Agilent	N5181A	MY50143868	Jul. 10, 2017	1 Year
Vector Signal Generator	Anritsu	MG3710A	6201599977	Mar. 27, 2017	1 Year
Power Meter	Anritsu	ML2495A	1218009	Jul. 12, 2017	1 Year
Power Sensor	Anritsu	MA2411B	1207252	Jul. 12, 2017	1 Year
Thermometer	YFE	YF-160A	130504591	Mar. 24, 2017	1 Year
Power Amplifier	AR	5S1G4	0339656	Sep. 15, 2017	1 Year
Power Amplifier	mini-circuits	ZVE-8G	05770420A	Sep. 15, 2017	1 Year
Attenuator	MTJ	MTJ6011-03	N/A	Sep. 15, 2017	1 Year
Attenuator	Woken	00800A1G01L-10	N/A	Sep. 15, 2017	1 Year
Directional Coupler	Woken	0110A05602O-10	11122702	Sep. 15, 2017	1 Year

## 6. Measurement Uncertainty

Source of Uncertainty	Uncertainty (± %)	Probability Distribution	Divisor	Ci (1g)	Ci (10g)	Standard Uncertainty (± %, 1g)	Standard Uncertainty (± %, 10g)	Vi
<b>Measurement System</b>								
Probe Calibration	6.0	Normal	1	1	1	6.0	6.0	∞
Axial Isotropy	4.7	Rectangular	√3	√0.5	√0.5	1.9	1.9	∞
Hemispherical Isotropy	9.6	Rectangular	√3	√0.5	√0.5	3.9	3.9	∞
Boundary Effect	1.0	Rectangular	√3	1	1	0.6	0.6	∞
Linearity	4.7	Rectangular	√3	1	1	2.7	2.7	∞
Detection Limits	0.25	Rectangular	√3	1	1	0.14	0.14	∞
Probe Modulation Response	3.5	Rectangular	√3	1	1	2.0	2.0	∞
Readout Electronics	0.3	Normal	1	1	1	0.3	0.3	∞
Response Time	0.0	Rectangular	√3	1	1	0.0	0.0	∞
Integration Time	1.7	Rectangular	√3	1	1	1.0	1.0	∞
RF Ambient Conditions – Noise	3.0	Rectangular	√3	1	1	1.7	1.7	∞
RF Ambient Conditions – Reflections	3.0	Rectangular	√3	1	1	1.7	1.7	∞
Probe Positioner Mechanical Tolerance	0.4	Rectangular	√3	1	1	0.2	0.2	∞
Probe Positioning with Respect to Phantom	2.9	Rectangular	√3	1	1	1.7	1.7	∞
Post-processing	2.0	Rectangular	√3	1	1	1.2	1.2	∞
<b>Test Sample Related</b>								
Test Sample Positioning	3.9 / 2.06	Normal	1	1	1	3.9	2.1	35
Device Holder Uncertainty	2.9 / 4.1	Normal	1	1	1	2.9	4.1	11
Power Drift of Measurement	5.0	Rectangular	√3	1	1	2.9	2.9	∞
Power Scaling	0.0	Rectangular	√3	1	1	0.0	0.0	∞
<b>Phantom and Setup</b>								
Phantom Uncertainty (Shape and Thickness Tolerances)	6.1	Rectangular	√3	1	1	3.5	3.5	∞
Liquid Conductivity ( Temperature Uncertainty)	3.24	Rectangular	√3	0.78	0.71	1.5	1.3	∞
Liquid Conductivity (Measured)	2.88	Normal	1	0.78	0.71	2.2	2.0	43
Liquid Permittivity (Temperature Uncertainty)	1.13	Rectangular	√3	0.23	0.26	0.2	0.2	∞
Liquid Permittivity (Measured)	2.50	Normal	1	0.23	0.26	0.6	0.7	54
<b>Combined Standard Uncertainty</b>						± 11.4 %	± 11.2 %	
<b>Expanded Uncertainty (K=2)</b>						± 22.8 %	± 22.4 %	

Head SAR Uncertainty Budget for Frequency Range of 300 MHz to 3 GHz

# FCC SAR Test Report

Source of Uncertainty	Uncertainty (± %)	Probability Distribution	Divisor	C <sub>i</sub> (1g)	C <sub>i</sub> (10g)	Standard Uncertainty (± %, 1g)	Standard Uncertainty (± %, 10g)	V <sub>i</sub>
<b>Measurement System</b>								
Probe Calibration	6.55	Normal	1	1	1	6.55	6.55	∞
Axial Isotropy	4.7	Rectangular	√3	0.7	0.7	1.9	1.9	∞
Hemispherical Isotropy	9.6	Rectangular	√3	0.7	0.7	3.9	3.9	∞
Boundary Effect	2.0	Rectangular	√3	1	1	1.2	1.2	∞
Linearity	4.7	Rectangular	√3	1	1	2.7	2.7	∞
Detection Limits	0.25	Rectangular	√3	1	1	0.14	0.14	∞
Probe Modulation Response	3.5	Rectangular	√3	1	1	2.0	2.0	∞
Readout Electronics	0.3	Normal	1	1	1	0.3	0.3	∞
Response Time	0.0	Rectangular	√3	1	1	0.0	0.0	∞
Integration Time	1.7	Rectangular	√3	1	1	1.0	1.0	∞
RF Ambient Conditions – Noise	3.0	Rectangular	√3	1	1	1.7	1.7	∞
RF Ambient Conditions – Reflections	3.0	Rectangular	√3	1	1	1.7	1.7	∞
Probe Positioner Mechanical Tolerance	0.4	Rectangular	√3	1	1	0.2	0.2	∞
Probe Positioning with Respect to Phantom	6.7	Rectangular	√3	1	1	3.9	3.9	∞
Post-processing	4.0	Rectangular	√3	1	1	2.3	2.3	∞
<b>Test Sample Related</b>								
Test Sample Positioning	3.9 / 2.06	Normal	1	1	1	3.9	2.1	35
Device Holder Uncertainty	2.9 / 4.1	Normal	1	1	1	2.9	4.1	11
Power Drift of Measurement	5.0	Rectangular	√3	1	1	2.9	2.9	∞
Power Scaling	0.0	Rectangular	√3	1	1	0.0	0.0	∞
<b>Phantom and Setup</b>								
Phantom Uncertainty (Shape and Thickness Tolerances)	6.6	Rectangular	√3	1	1	3.8	3.8	∞
Liquid Conductivity ( Temperature Uncertainty)	3.24	Rectangular	√3	0.78	0.71	1.5	1.3	∞
Liquid Conductivity (Measured)	2.88	Normal	1	0.78	0.71	2.2	2.0	43
Liquid Permittivity (Temperature Uncertainty)	1.13	Rectangular	√3	0.23	0.26	0.2	0.2	∞
Liquid Permittivity (Measured)	2.50	Normal	1	0.23	0.26	0.6	0.7	54
<b>Combined Standard Uncertainty</b>						± 12.5 %	± 12.3 %	
<b>Expanded Uncertainty (K=2)</b>						± 25.0 %	± 24.6 %	

## Head SAR Uncertainty Budget for Frequency Range of 3 GHz to 6 GHz

# FCC SAR Test Report

Source of Uncertainty	Uncertainty (± %)	Probability Distribution	Divisor	Ci (1g)	Ci (10g)	Standard Uncertainty (± %, 1g)	Standard Uncertainty (± %, 10g)	Vi
<b>Measurement System</b>								
Probe Calibration	6.0	Normal	1	1	1	6.0	6.0	∞
Axial Isotropy	4.7	Rectangular	√3	√0.5	√0.5	1.9	1.9	∞
Hemispherical Isotropy	9.6	Rectangular	√3	√0.5	√0.5	3.9	3.9	∞
Boundary Effect	1.0	Rectangular	√3	1	1	0.6	0.6	∞
Linearity	4.7	Rectangular	√3	1	1	2.7	2.7	∞
Detection Limits	0.25	Rectangular	√3	1	1	0.14	0.14	∞
Probe Modulation Response	3.5	Rectangular	√3	1	1	2.0	2.0	∞
Readout Electronics	0.3	Normal	1	1	1	0.3	0.3	∞
Response Time	0.0	Rectangular	√3	1	1	0.0	0.0	∞
Integration Time	1.7	Rectangular	√3	1	1	1.0	1.0	∞
RF Ambient Conditions – Noise	3.0	Rectangular	√3	1	1	1.7	1.7	∞
RF Ambient Conditions – Reflections	3.0	Rectangular	√3	1	1	1.7	1.7	∞
Probe Positioner Mechanical Tolerance	0.4	Rectangular	√3	1	1	0.2	0.2	∞
Probe Positioning with Respect to Phantom	2.9	Rectangular	√3	1	1	1.7	1.7	∞
Post-processing	2.0	Rectangular	√3	1	1	1.2	1.2	∞
<b>Test Sample Related</b>								
Test Sample Positioning	4.38 / 1.35	Normal	1	1	1	4.4	1.4	29
Device Holder Uncertainty	2.9 / 4.1	Normal	1	1	1	2.9	4.1	11
Power Drift of Measurement	5.0	Rectangular	√3	1	1	2.9	2.9	∞
Power Scaling	0.0	Rectangular	√3	1	1	0.0	0.0	∞
<b>Phantom and Setup</b>								
Phantom Uncertainty (Shape and Thickness Tolerances)	7.2	Rectangular	√3	1	1	4.2	4.2	∞
Liquid Conductivity ( Temperature Uncertainty)	3.24	Rectangular	√3	0.78	0.71	1.5	1.3	∞
Liquid Conductivity (Measured)	2.88	Normal	1	0.78	0.71	2.2	2.0	43
Liquid Permittivity (Temperature Uncertainty)	1.13	Rectangular	√3	0.23	0.26	0.2	0.2	∞
Liquid Permittivity (Measured)	2.50	Normal	1	0.23	0.26	0.6	0.7	54
<b>Combined Standard Uncertainty</b>						± 11.8 %	± 11.3 %	
<b>Expanded Uncertainty (K=2)</b>						± 23.6 %	± 22.6 %	

## Body SAR Uncertainty Budget for Frequency Range of 300 MHz to 3 GHz

# FCC SAR Test Report

Source of Uncertainty	Uncertainty (± %)	Probability Distribution	Divisor	C <sub>i</sub> (1g)	C <sub>i</sub> (10g)	Standard Uncertainty (± %, 1g)	Standard Uncertainty (± %, 10g)	V <sub>i</sub>
<b>Measurement System</b>								
Probe Calibration	6.55	Normal	1	1	1	6.55	6.55	∞
Axial Isotropy	4.7	Rectangular	√3	0.7	0.7	1.9	1.9	∞
Hemispherical Isotropy	9.6	Rectangular	√3	0.7	0.7	3.9	3.9	∞
Boundary Effect	2.0	Rectangular	√3	1	1	1.2	1.2	∞
Linearity	4.7	Rectangular	√3	1	1	2.7	2.7	∞
Detection Limits	0.25	Rectangular	√3	1	1	0.14	0.14	∞
Probe Modulation Response	3.5	Rectangular	√3	1	1	2.0	2.0	∞
Readout Electronics	0.3	Normal	1	1	1	0.3	0.3	∞
Response Time	0.0	Rectangular	√3	1	1	0.0	0.0	∞
Integration Time	1.7	Rectangular	√3	1	1	1.0	1.0	∞
RF Ambient Conditions – Noise	3.0	Rectangular	√3	1	1	1.7	1.7	∞
RF Ambient Conditions – Reflections	3.0	Rectangular	√3	1	1	1.7	1.7	∞
Probe Positioner Mechanical Tolerance	0.4	Rectangular	√3	1	1	0.2	0.2	∞
Probe Positioning with Respect to Phantom	6.7	Rectangular	√3	1	1	3.9	3.9	∞
Post-processing	4.0	Rectangular	√3	1	1	2.3	2.3	∞
<b>Test Sample Related</b>								
Test Sample Positioning	4.38 / 1.35	Normal	1	1	1	4.4	1.4	29
Device Holder Uncertainty	2.9 / 4.1	Normal	1	1	1	2.9	4.1	11
Power Drift of Measurement	5.0	Rectangular	√3	1	1	2.9	2.9	∞
Power Scaling	0.0	Rectangular	√3	1	1	0.0	0.0	∞
<b>Phantom and Setup</b>								
Phantom Uncertainty (Shape and Thickness Tolerances)	7.6	Rectangular	√3	1	1	4.4	4.4	∞
Liquid Conductivity ( Temperature Uncertainty)	3.24	Rectangular	√3	0.78	0.71	1.5	1.3	∞
Liquid Conductivity (Measured)	2.88	Normal	1	0.78	0.71	2.2	2.0	43
Liquid Permittivity (Temperature Uncertainty)	1.13	Rectangular	√3	0.23	0.26	0.2	0.2	∞
Liquid Permittivity (Measured)	2.50	Normal	1	0.23	0.26	0.6	0.7	54
<b>Combined Standard Uncertainty</b>						± 12.8 %	± 12.4 %	
<b>Expanded Uncertainty (K=2)</b>						± 25.6 %	± 24.8 %	

**Body SAR Uncertainty Budget for Frequency Range of 3 GHz to 6 GHz**

## **7. Information on the Testing Laboratories**

We, Bureau Veritas Consumer Products Services (H.K.) Ltd., Taoyuan Branch, were founded in 1988 to provide our best service in EMC, Radio, Telecom and Safety consultation. Our laboratories are accredited and approved according to ISO/IEC 17025.

If you have any comments, please feel free to contact us at the following:

**Taiwan HwaYa EMC/RF/Safety/Telecom Lab:**

Add: No. 19, Hwa Ya 2nd Rd, Wen Hwa Vil., Kwei Shan Hsiang, Taoyuan Hsien 333, Taiwan, R.O.C.

Tel: 886-3-318-3232

Fax: 886-3-327-0892

**Taiwan LinKo EMC/RF Lab:**

Add: No. 47-2, 14th Ling, Chia Pau Vil., Linkou Dist., New Taipei City 244, Taiwan, R.O.C.

Tel: 886-2-2605-2180

Fax: 886-2-2605-1924

**Taiwan HsinChu EMC/RF Lab:**

Add: E-2, No.1, Li Hsin 1<sup>st</sup> Road, Hsinchu Science Park, Hsinchu City 30078, Taiwan, R.O.C.

Tel: 886-3-593-5343

Fax: 886-3-593-5342

**Email:** [service.adt@tw.bureauveritas.com](mailto:service.adt@tw.bureauveritas.com)

**Web Site:** [www.adt.com.tw](http://www.adt.com.tw)

The road map of all our labs can be found in our web site also.

---END---

## Appendix A. SAR Plots of System Verification

The plots for system verification with largest deviation for each SAR system combination are shown as follows.



### System Check\_B750\_171028

**DUT: Dipole 750 MHz; Type: D750V3; SN: 1013**

Communication System: CW; Frequency: 750 MHz; Duty Cycle: 1:1

Medium: B06T09N1\_1028 Medium parameters used:  $f = 750 \text{ MHz}$ ;  $\sigma = 0.959 \text{ S/m}$ ;  $\epsilon_r = 56.412$ ;  $\rho = 1000 \text{ kg/m}^3$

Ambient Temperature : 23.7 °C ; Liquid Temperature : 23.2 °C

DASY5 Configuration:

- Probe: EX3DV4 - SN3971; ConvF(10.61, 10.61, 10.61); Calibrated: 2017/03/24;
- Sensor-Surface: 1.4mm (Mechanical Surface Detection)
- Electronics: DAE4 Sn1431; Calibrated: 2017/03/20
- Phantom: ELI Phantom\_1043; Type: QDOVA; Serial:
- Measurement SW: DASY52, Version 52.8 (8); SEMCAD X Version 14.6.10 (7373)

**Pin=250mW/Area Scan (61x81x1):** Interpolated grid:  $dx=1.500 \text{ mm}$ ,  $dy=1.500 \text{ mm}$   
Maximum value of SAR (interpolated) = 2.85 W/kg

**Pin=250mW/Zoom Scan (5x5x7)/Cube 0:** Measurement grid:  $dx=8\text{mm}$ ,  $dy=8\text{mm}$ ,  $dz=5\text{mm}$   
Reference Value = 56.61 V/m; Power Drift = -0.02 dB  
Peak SAR (extrapolated) = 3.18 W/kg  
**SAR(1 g) = 2.12 W/kg; SAR(10 g) = 1.41 W/kg**  
Maximum value of SAR (measured) = 2.82 W/kg

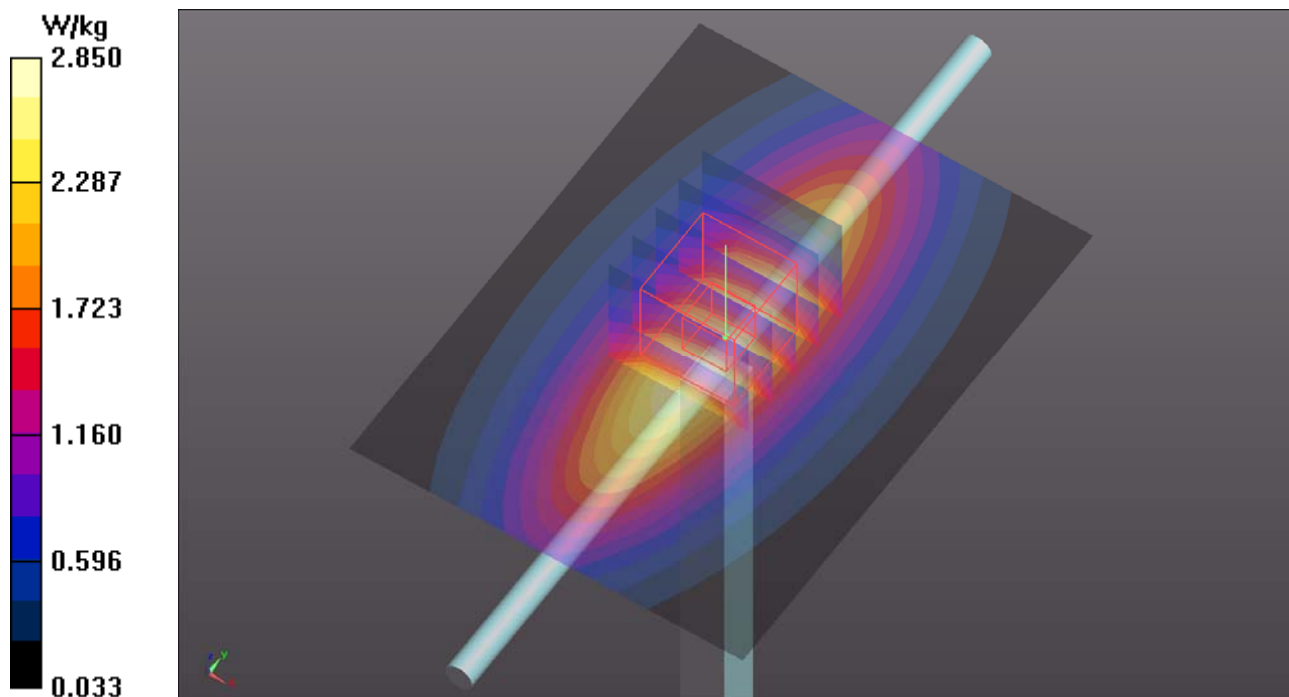

### System Check\_B835\_171028

**DUT: Dipole 835 MHz; Type: D835V2; SN: 4d121**

Communication System: CW; Frequency: 835 MHz; Duty Cycle: 1:1

Medium: B07T10N1\_1028 Medium parameters used:  $f = 835 \text{ MHz}$ ;  $\sigma = 1.017 \text{ S/m}$ ;  $\epsilon_r = 57.276$ ;  $\rho = 1000 \text{ kg/m}^3$

Ambient Temperature :  $23.8 \text{ }^\circ\text{C}$  ; Liquid Temperature :  $23.3 \text{ }^\circ\text{C}$

DASY5 Configuration:

- Probe: EX3DV4 - SN3971; ConvF(10.52, 10.52, 10.52); Calibrated: 2017/03/24;
- Sensor-Surface: 1.4mm (Mechanical Surface Detection)
- Electronics: DAE4 Sn1431; Calibrated: 2017/03/20
- Phantom: ELI Phantom\_1043; Type: QDOVA;
- Measurement SW: DASY52, Version 52.8 (8); SEMCAD X Version 14.6.10 (7373)

**Pin=250mW/Area Scan (61x61x1):** Interpolated grid:  $dx=1.500 \text{ mm}$ ,  $dy=1.500 \text{ mm}$   
Maximum value of SAR (interpolated) =  $3.18 \text{ W/kg}$

**Pin=250mW/Zoom Scan (5x5x7)/Cube 0:** Measurement grid:  $dx=8\text{mm}$ ,  $dy=8\text{mm}$ ,  $dz=5\text{mm}$   
Reference Value =  $51.95 \text{ V/m}$ ; Power Drift =  $-0.13 \text{ dB}$   
Peak SAR (extrapolated) =  $3.60 \text{ W/kg}$   
**SAR(1 g) =  $2.38 \text{ W/kg}$ ; SAR(10 g) =  $1.55 \text{ W/kg}$**   
Maximum value of SAR (measured) =  $3.19 \text{ W/kg}$

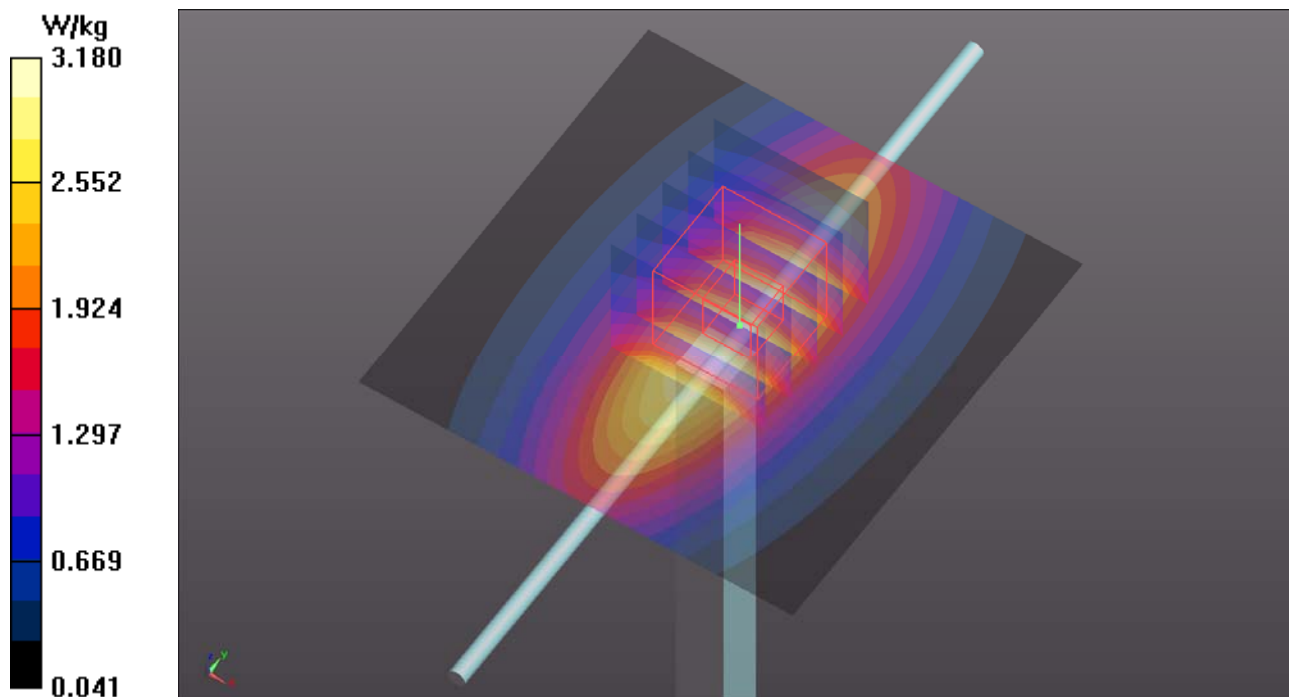

### System Check\_B1750\_171028

**DUT: Dipole 1750 MHz; Type: D1750V2; SN: 1055**

Communication System: CW; Frequency: 1750 MHz; Duty Cycle: 1:1

Medium: B16T20N1\_1028 Medium parameters used:  $f = 1750$  MHz;  $\sigma = 1.435$  S/m;  $\epsilon_r = 52.026$ ;  $\rho = 1000$  kg/m<sup>3</sup>

Ambient Temperature : 23.8 °C ; Liquid Temperature : 23.3 °C

DASY5 Configuration:

- Probe: EX3DV4 - SN3971; ConvF(8.51, 8.51, 8.51); Calibrated: 2017/03/24;
- Sensor-Surface: 1.4mm (Mechanical Surface Detection)
- Electronics: DAE4 Sn1431; Calibrated: 2017/03/20
- Phantom: ELI Phantom\_1245; Type: QDOVA;
- Measurement SW: DASY52, Version 52.8 (8); SEMCAD X Version 14.6.10 (7373)

**Pin=250mW/Area Scan (61x61x1):** Interpolated grid: dx=1.500 mm, dy=1.500 mm  
Maximum value of SAR (interpolated) = 13.2 W/kg

**Pin=250mW/Zoom Scan (5x5x7)/Cube 0:** Measurement grid: dx=8mm, dy=8mm, dz=5mm  
Reference Value = 95.30 V/m; Power Drift = 0.02 dB  
Peak SAR (extrapolated) = 15.8 W/kg  
**SAR(1 g) = 9.1 W/kg; SAR(10 g) = 4.92 W/kg**  
Maximum value of SAR (measured) = 12.7 W/kg

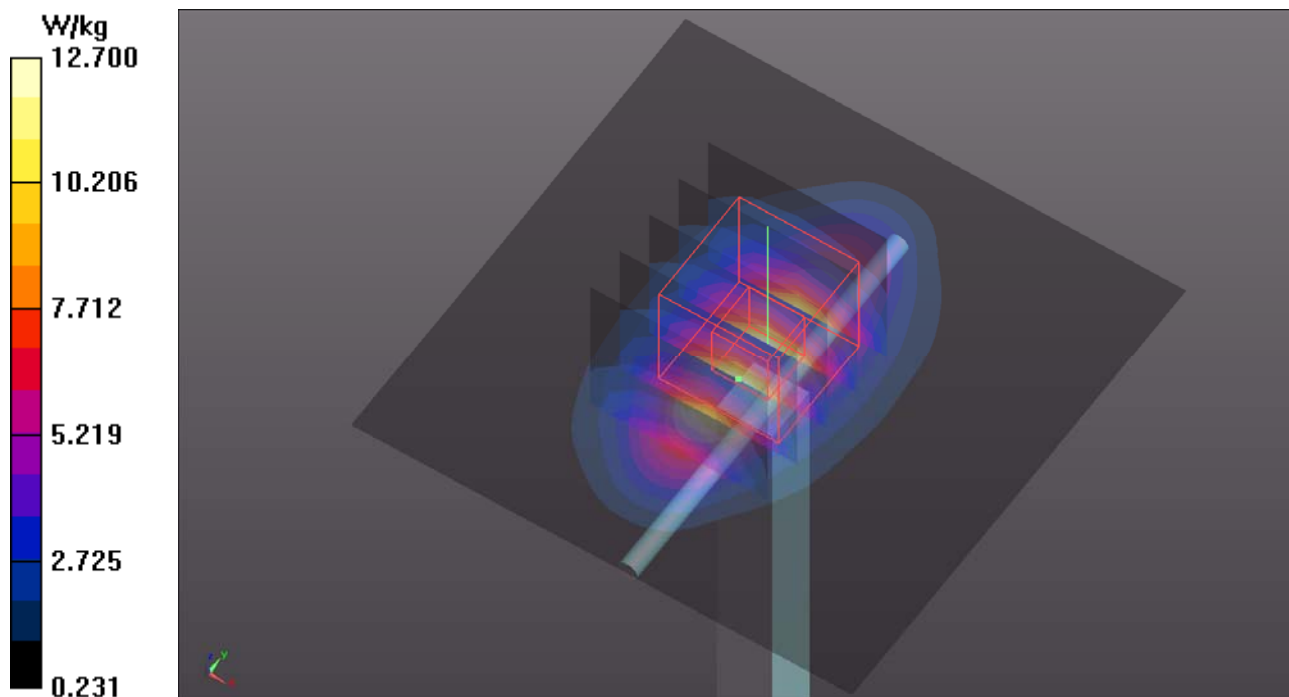

### System Check\_B1900\_171028

**DUT: Dipole 1900 MHz; Type: D1900V2; SN: 5d036**

Communication System: CW; Frequency: 1900 MHz; Duty Cycle: 1:1

Medium: B16T20N1\_1028 Medium parameters used:  $f = 1900$  MHz;  $\sigma = 1.584$  S/m;  $\epsilon_r = 51.609$ ;  $\rho = 1000$  kg/m<sup>3</sup>

Ambient Temperature : 23.7 °C ; Liquid Temperature : 23.2 °C

DASY5 Configuration:

- Probe: EX3DV4 - SN3971; ConvF(8.26, 8.26, 8.26); Calibrated: 2017/03/24;
- Sensor-Surface: 1.4mm (Mechanical Surface Detection)
- Electronics: DAE4 Sn1431; Calibrated: 2017/03/20
- Phantom: ELI Phantom\_1245; Type: QDOVA;
- Measurement SW: DASY52, Version 52.8 (8); SEMCAD X Version 14.6.10 (7373)

**Pin=250mW/Area Scan (61x61x1):** Interpolated grid: dx=1.500 mm, dy=1.500 mm  
Maximum value of SAR (interpolated) = 14.8 W/kg

**Pin=250mW/Zoom Scan (5x5x7)/Cube 0:** Measurement grid: dx=8mm, dy=8mm, dz=5mm  
Reference Value = 96.96 V/m; Power Drift = 0.01 dB  
Peak SAR (extrapolated) = 18.3 W/kg  
**SAR(1 g) = 10.2 W/kg; SAR(10 g) = 5.33 W/kg**  
Maximum value of SAR (measured) = 14.6 W/kg

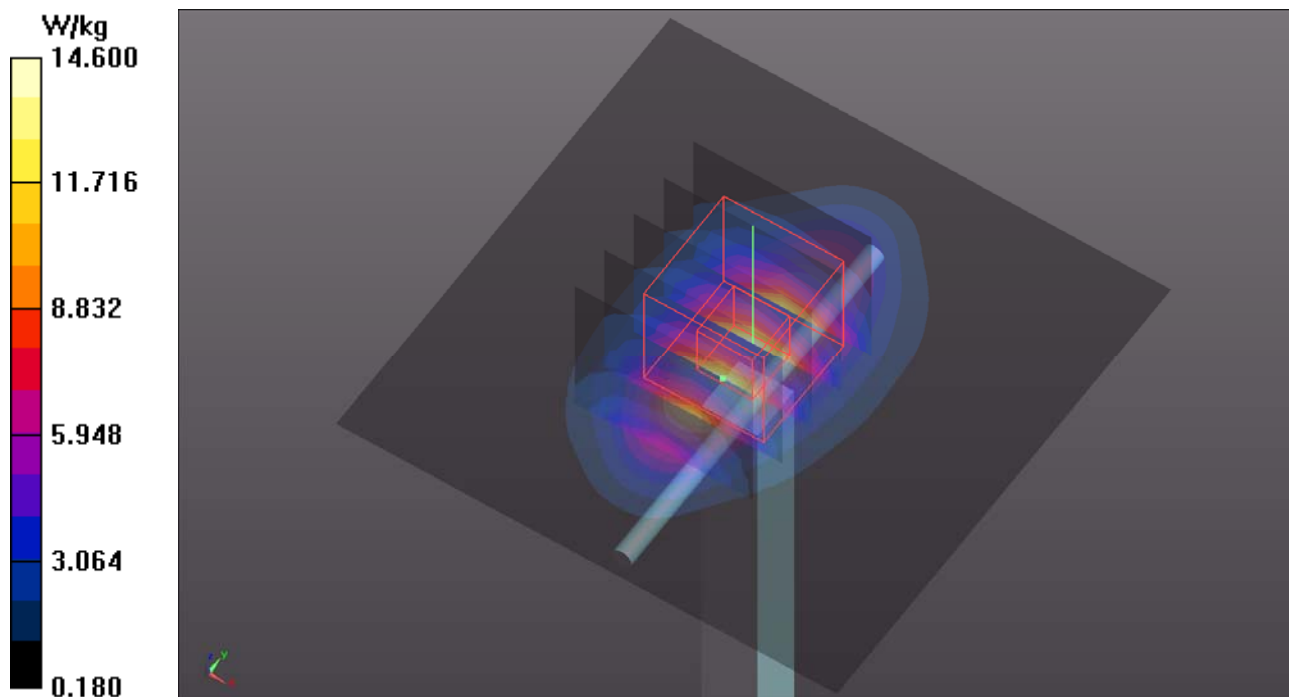

### System Check\_B2300\_171028

**DUT: Dipole 2300 MHz; Type: D2300V2; SN: 1004**

Communication System: CW; Frequency: 2300 MHz; Duty Cycle: 1:1

Medium: B19T27N5\_1028 Medium parameters used:  $f = 2300$  MHz;  $\sigma = 1.854$  S/m;  $\epsilon_r = 51.508$ ;  $\rho = 1000$  kg/m<sup>3</sup>

Ambient Temperature : 23.6 °C ; Liquid Temperature : 23.1 °C

DASY5 Configuration:

- Probe: EX3DV4 - SN3971; ConvF(7.85, 7.85, 7.85); Calibrated: 2017/03/24;
- Sensor-Surface: 1.4mm (Mechanical Surface Detection)
- Electronics: DAE4 Sn1431; Calibrated: 2017/03/20
- Phantom: ELI Phantom\_1043; Type: QDOVA;
- Measurement SW: DASY52, Version 52.8 (8); SEMCAD X Version 14.6.10 (7373)

**Pin=250mW/Area Scan (81x81x1):** Interpolated grid: dx=1.200 mm, dy=1.200 mm  
Maximum value of SAR (interpolated) = 18.3 W/kg

**Pin=250mW/Zoom Scan (7x7x7)/Cube 0:** Measurement grid: dx=5mm, dy=5mm, dz=5mm  
Reference Value = 100.2 V/m; Power Drift = 0.02 dB  
Peak SAR (extrapolated) = 23.7 W/kg  
**SAR(1 g) = 12.2 W/kg; SAR(10 g) = 5.95 W/kg**  
Maximum value of SAR (measured) = 18.2 W/kg

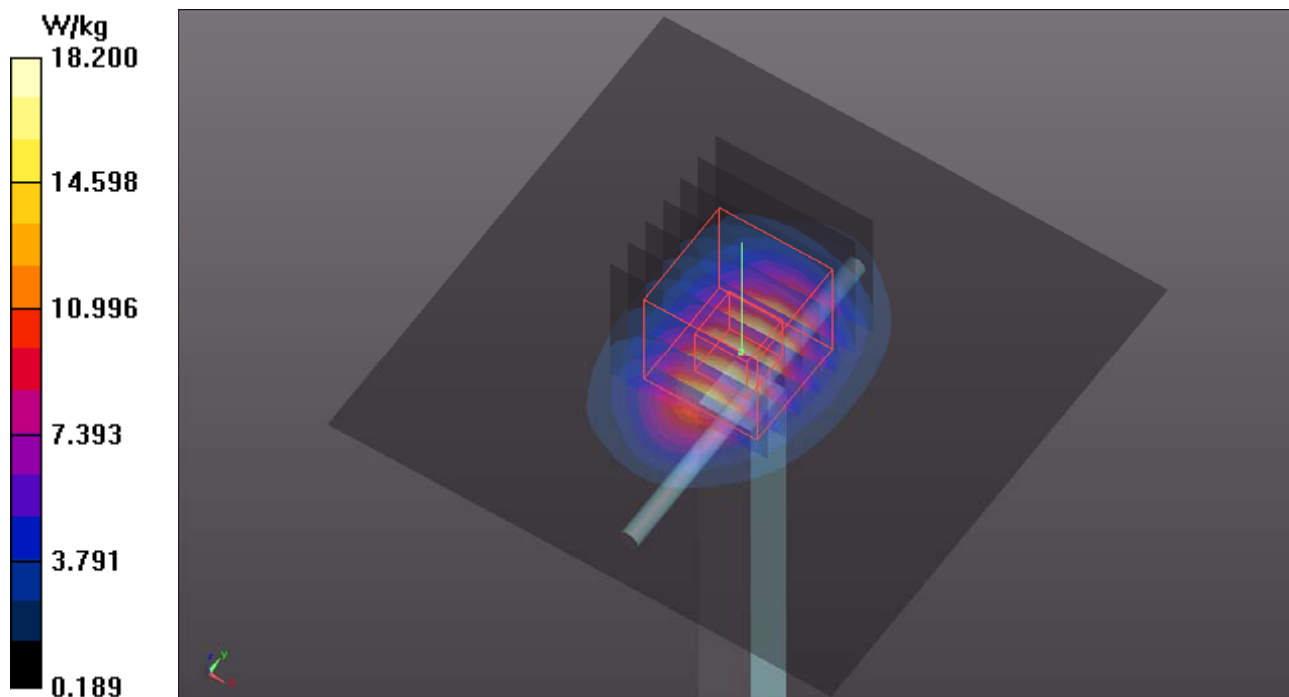

## System Check\_B2600\_171028

**DUT: Dipole 2600 MHz; Type: D2600V2; SN: 1020**

Communication System: CW; Frequency: 2600 MHz; Duty Cycle: 1:1

Medium: B19T27N5\_1028 Medium parameters used:  $f = 2600$  MHz;  $\sigma = 2.188$  S/m;  $\epsilon_r = 50.649$ ;  $\rho = 1000$  kg/m<sup>3</sup>

Ambient Temperature : 23.7 °C ; Liquid Temperature : 23.2 °C

DASY5 Configuration:

- Probe: EX3DV4 - SN3971; ConvF(7.32, 7.32, 7.32); Calibrated: 2017/03/24;
- Sensor-Surface: 1.4mm (Mechanical Surface Detection)
- Electronics: DAE4 Sn1431; Calibrated: 2017/03/20
- Phantom: ELI Phantom\_1043; Type: QDOVA;
- Measurement SW: DASY52, Version 52.8 (8); SEMCAD X Version 14.6.10 (7373)

**Pin=250mW/Area Scan (81x81x1):** Interpolated grid: dx=1.200 mm, dy=1.200 mm

Maximum value of SAR (interpolated) = 21.8 W/kg

**Pin=250mW/Zoom Scan (7x7x7)/Cube 0:** Measurement grid: dx=5mm, dy=5mm, dz=5mm

Reference Value = 102.3 V/m; Power Drift = -0.09 dB

Peak SAR (extrapolated) = 27.6 W/kg

**SAR(1 g) = 12.6 W/kg; SAR(10 g) = 5.61 W/kg**

Maximum value of SAR (measured) = 21.9 W/kg

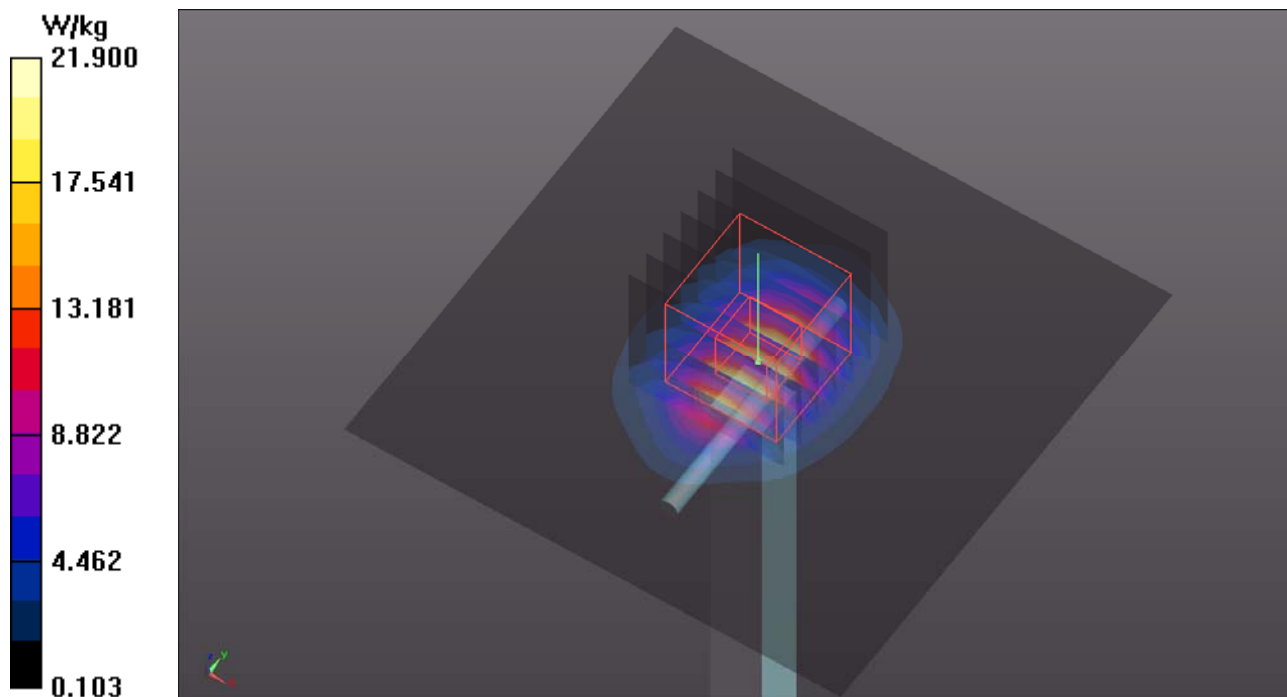

### System Check\_B2450\_171020

**DUT: Dipole 2450 MHz; Type: D2450V2; SN: 737**

Communication System: CW; Frequency: 2450 MHz; Duty Cycle: 1:1

Medium: B19T27N5\_1020 Medium parameters used:  $f = 2450$  MHz;  $\sigma = 1.969$  S/m;  $\epsilon_r = 51.42$ ;  $\rho = 1000$  kg/m<sup>3</sup>

Ambient Temperature : 23.5 °C ; Liquid Temperature : 23.3 °C

DASY5 Configuration:

- Probe: EX3DV4 - SN3971; ConvF(7.67, 7.67, 7.67); Calibrated: 2017/03/24;
- Sensor-Surface: 306mm (Mechanical Surface Detection)
- Electronics: DAE4 Sn1431; Calibrated: 2017/03/20
- Phantom: ELI Phantom\_1245; Type: QDOVA;
- Measurement SW: DASY52, Version 52.8 (8); SEMCAD X Version 14.6.10 (7373)

**Pin=250mW/Area Scan (81x81x1):** Interpolated grid: dx=1.200 mm, dy=1.200 mm  
Maximum value of SAR (interpolated) = 17.8 W/kg

**Pin=250mW/Zoom Scan (7x7x7)/Cube 0:** Measurement grid: dx=5mm, dy=5mm, dz=5mm  
Reference Value = 95.70 V/m; Power Drift = 0.02 dB  
Peak SAR (extrapolated) = 23.6 W/kg  
**SAR(1 g) = 11.7 W/kg; SAR(10 g) = 5.46 W/kg**  
Maximum value of SAR (measured) = 17.7 W/kg

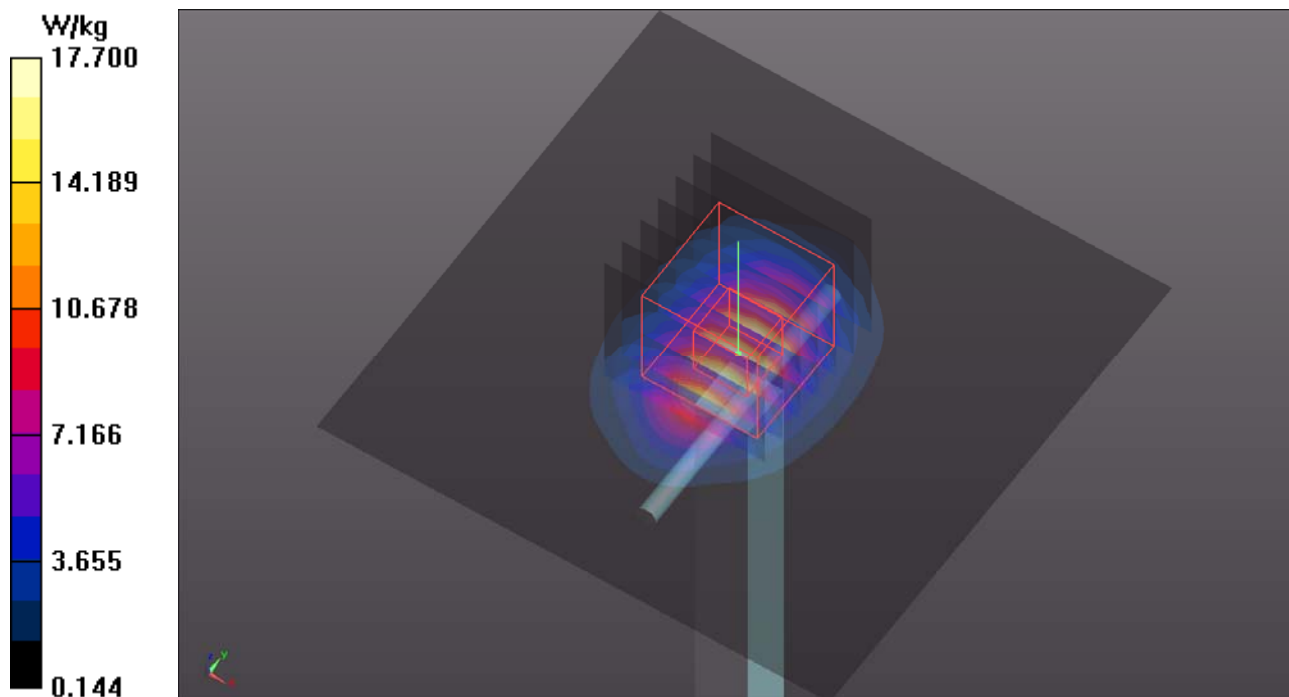

### System Check\_B5250\_171028

**DUT: Dipole 5 GHz; Type: D5GHzV2; SN: 1019**

Communication System: CW; Frequency: 5250 MHz; Duty Cycle: 1:1

Medium: B34T60N1\_1028 Medium parameters used:  $f = 5250$  MHz;  $\sigma = 5.381$  S/m;  $\epsilon_r = 49.124$ ;  $\rho = 1000$  kg/m<sup>3</sup>

Ambient Temperature : 23.8 °C ; Liquid Temperature : 23.3 °C

DASY5 Configuration:

- Probe: EX3DV4 - SN7375; ConvF(4.82, 4.82, 4.82); Calibrated: 2016/11/16;
- Sensor-Surface: 1.4mm (Mechanical Surface Detection)
- Electronics: DAE3 Sn579; Calibrated: 2017/08/17
- Phantom: ELI Phantom\_1206; Type: QDOVA;
- Measurement SW: DASY52, Version 52.8 (8); SEMCAD X Version 14.6.10 (7373)

**Pin=100mW/Area Scan (91x91x1):** Interpolated grid: dx=1.000 mm, dy=1.000 mm  
Maximum value of SAR (interpolated) = 16.9 W/kg

**Pin=100mW/Zoom Scan (7x7x12)/Cube 0:** Measurement grid: dx=4mm, dy=4mm, dz=2mm  
Reference Value = 55.60 V/m; Power Drift = -0.14 dB  
Peak SAR (extrapolated) = 30.5 W/kg  
**SAR(1 g) = 7.54 W/kg; SAR(10 g) = 2.17 W/kg**  
Maximum value of SAR (measured) = 19.0 W/kg

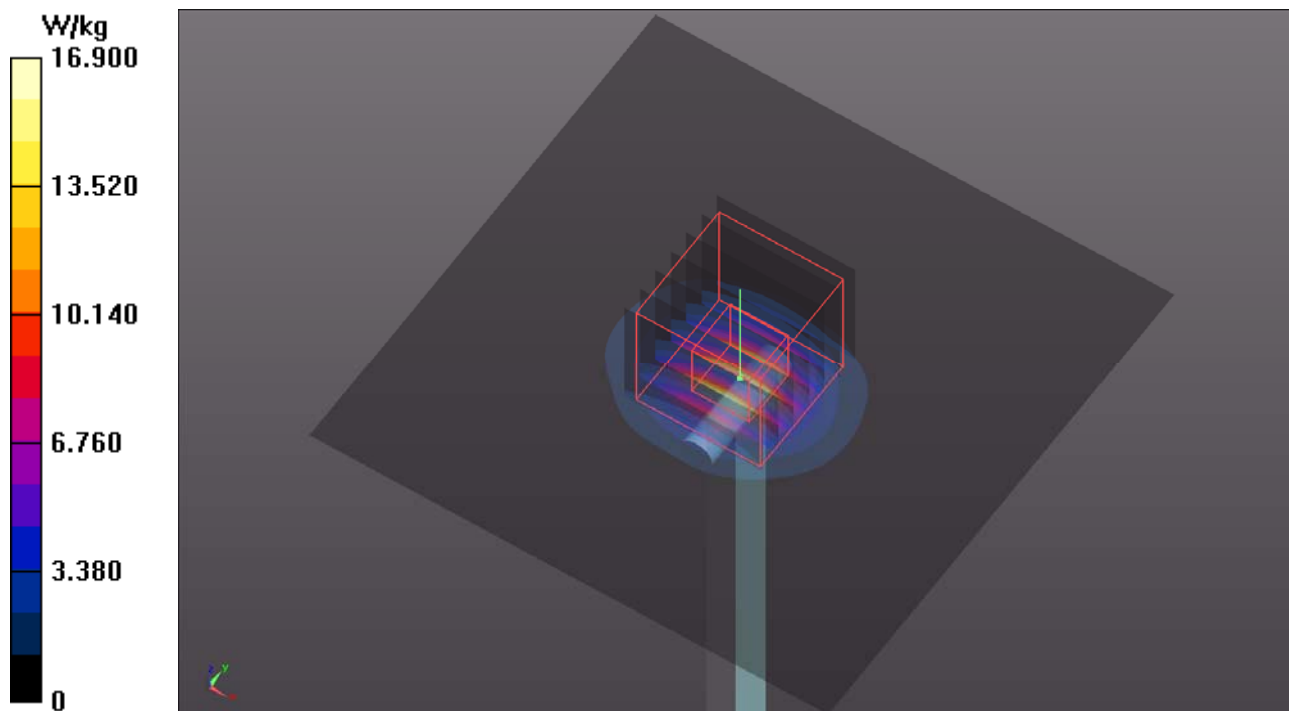



### System Check\_B5600\_171028

**DUT: Dipole 5 GHz; Type: D5GHzV2; SN: 1019**

Communication System: CW; Frequency: 5600 MHz; Duty Cycle: 1:1

Medium: B34T60N1\_1028 Medium parameters used:  $f = 5600$  MHz;  $\sigma = 5.884$  S/m;  $\epsilon_r = 48.452$ ;  $\rho = 1000$  kg/m<sup>3</sup>

Ambient Temperature : 23.8 °C ; Liquid Temperature : 23.3 °C

DASY5 Configuration:

- Probe: EX3DV4 - SN7375; ConvF(3.99, 3.99, 3.99); Calibrated: 2016/12/08;
- Sensor-Surface: 1.4mm (Mechanical Surface Detection)
- Electronics: DAE3 Sn579; Calibrated: 2017/08/17
- Phantom: ELI Phantom\_1206; Type: QDOVA;
- Measurement SW: DASY52, Version 52.8 (8); SEMCAD X Version 14.6.10 (7373)

**Pin=100mW/Area Scan (91x91x1):** Interpolated grid: dx=1.000 mm, dy=1.000 mm  
Maximum value of SAR (interpolated) = 15.4 W/kg

**Pin=100mW/Zoom Scan (7x7x12)/Cube 0:** Measurement grid: dx=4mm, dy=4mm, dz=2mm  
Reference Value = 56.15 V/m; Power Drift = 0.09 dB  
Peak SAR (extrapolated) = 33.7 W/kg  
**SAR(1 g) = 7.52 W/kg; SAR(10 g) = 2.08 W/kg**  
Maximum value of SAR (measured) = 16.2 W/kg

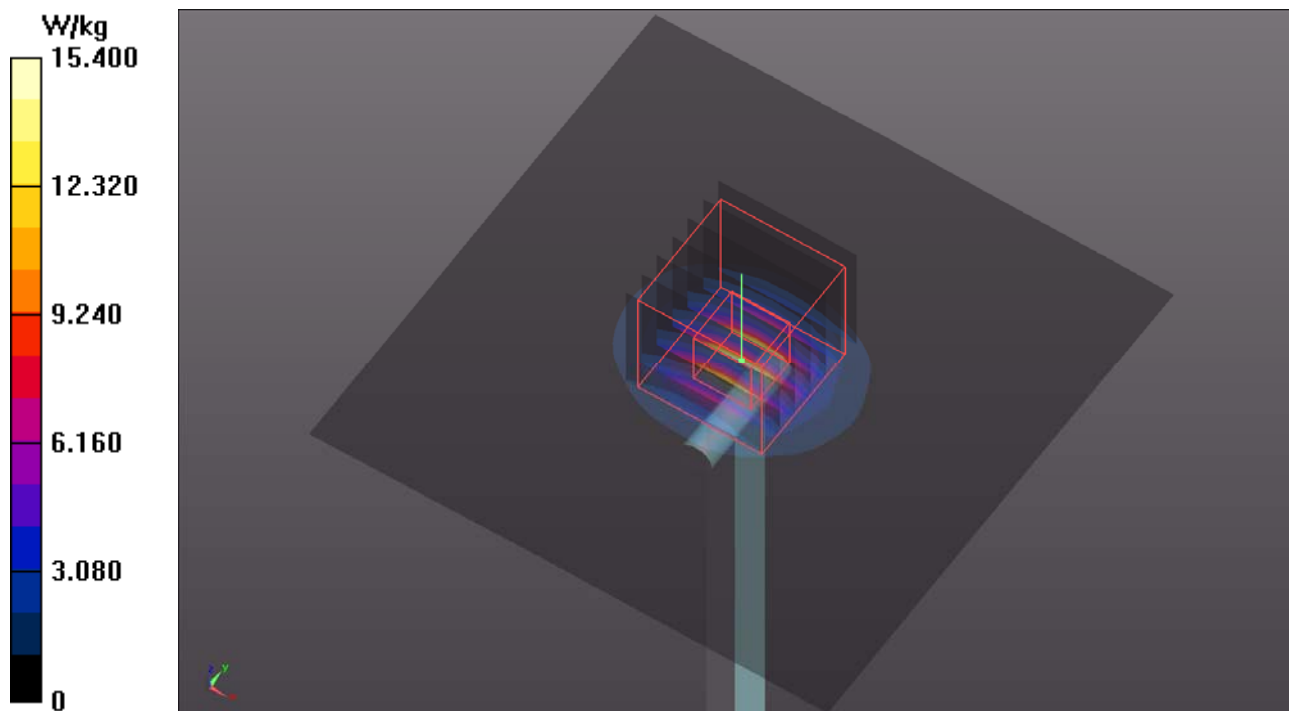

### System Check\_B5800\_171028

**DUT: Dipole 5 GHz; Type: D5GHzV2; SN: 1019**

Communication System: CW; Frequency: 5800 MHz; Duty Cycle: 1:1

Medium: B34T60N1\_1028 Medium parameters used:  $f = 5800$  MHz;  $\sigma = 6.141$  S/m;  $\epsilon_r = 47.955$ ;  $\rho = 1000$  kg/m<sup>3</sup>

Ambient Temperature : 23.8 °C ; Liquid Temperature : 23.3 °C

DASY5 Configuration:

- Probe: EX3DV4 - SN7375; ConvF(4.08, 4.08, 4.08); Calibrated: 2016/12/08;
- Sensor-Surface: 1.4mm (Mechanical Surface Detection)
- Electronics: DAE3 Sn579; Calibrated: 2017/08/17
- Phantom: ELI Phantom\_1206; Type: QDOVA;
- Measurement SW: DASY52, Version 52.8 (8); SEMCAD X Version 14.6.10 (7373)

**Pin=100mW/Area Scan (91x91x1):** Interpolated grid: dx=1.000 mm, dy=1.000 mm  
Maximum value of SAR (interpolated) = 19.3 W/kg

**Pin=100mW/Zoom Scan (7x7x12)/Cube 0:** Measurement grid: dx=4mm, dy=4mm, dz=2mm  
Reference Value = 58.13 V/m; Power Drift = -0.08 dB  
Peak SAR (extrapolated) = 35.7 W/kg  
**SAR(1 g) = 7.93 W/kg; SAR(10 g) = 2.24 W/kg**  
Maximum value of SAR (measured) = 21.0 W/kg

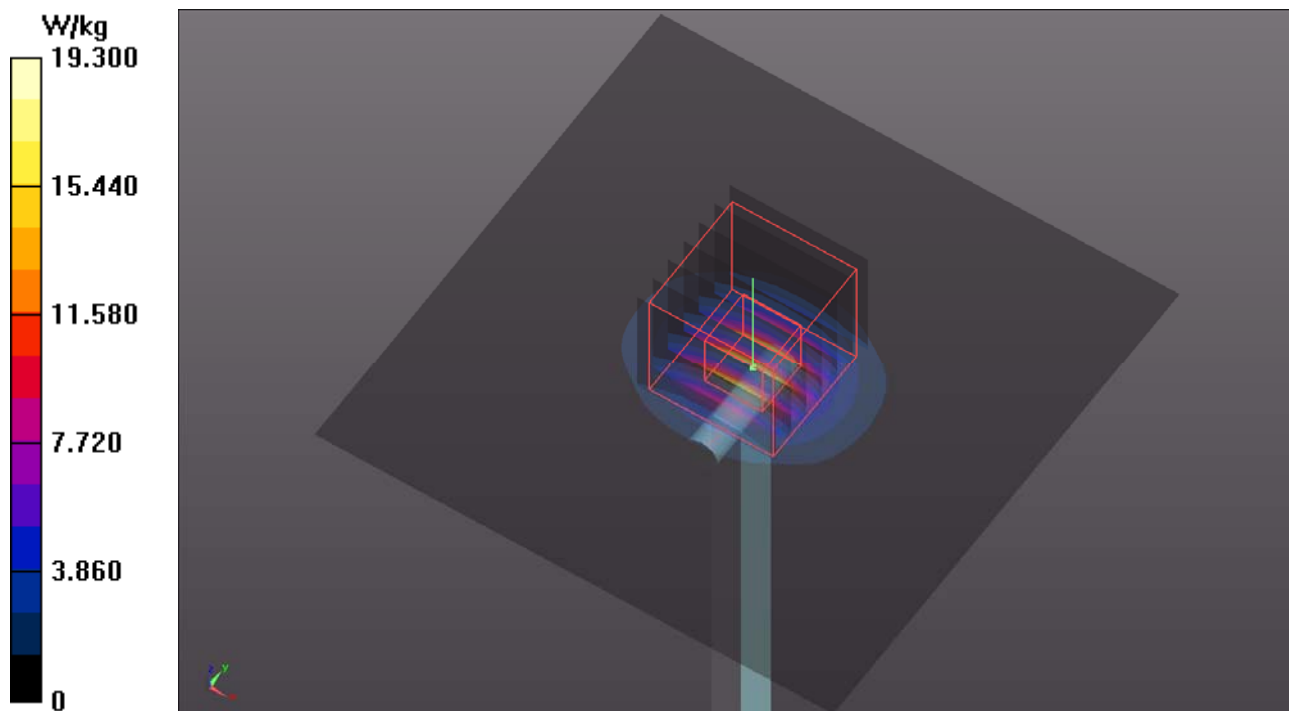

### Appendix B. SAR Plots of SAR Measurement

The SAR plots for highest measured SAR in each exposure configuration, wireless mode and frequency band combination, and measured SAR > 1.5 W/kg are shown as follows.

### P01 WCDMA II\_RMC12.2K\_Left Side\_0cm\_Ch9400

**DUT: 170927C14**

Communication System: WCDMA; Frequency: 1880 MHz; Duty Cycle: 1:1

Medium: B16T20N1\_1028 Medium parameters used:  $f = 1880$  MHz;  $\sigma = 1.563$  S/m;  $\epsilon_r = 51.654$ ;  $\rho = 1000$  kg/m<sup>3</sup>

Ambient Temperature : 23.7 °C ; Liquid Temperature : 23.2 °C

DASY5 Configuration:

- Probe: EX3DV4 - SN3971; ConvF(8.26, 8.26, 8.26); Calibrated: 2017/03/24;
- Sensor-Surface: 1.4mm (Mechanical Surface Detection)
- Electronics: DAE4 Sn1431; Calibrated: 2017/03/20
- Phantom: ELI Phantom\_1245; Type: QDOVA;
- Measurement SW: DASY52, Version 52.8 (8); SEMCAD X Version 14.6.10 (7373)

- **Area Scan (51x211x1):** Interpolated grid: dx=1.500 mm, dy=1.500 mm

Maximum value of SAR (interpolated) = 2.58 W/kg

- **Zoom Scan (5x5x7)/Cube 0:** Measurement grid: dx=8mm, dy=8mm, dz=5mm

Reference Value = 36.69 V/m; Power Drift = -0.17 dB

Peak SAR (extrapolated) = 3.26 W/kg

**SAR(1 g) = 1.55 W/kg; SAR(10 g) = 0.736 W/kg**

Maximum value of SAR (measured) = 2.69 W/kg

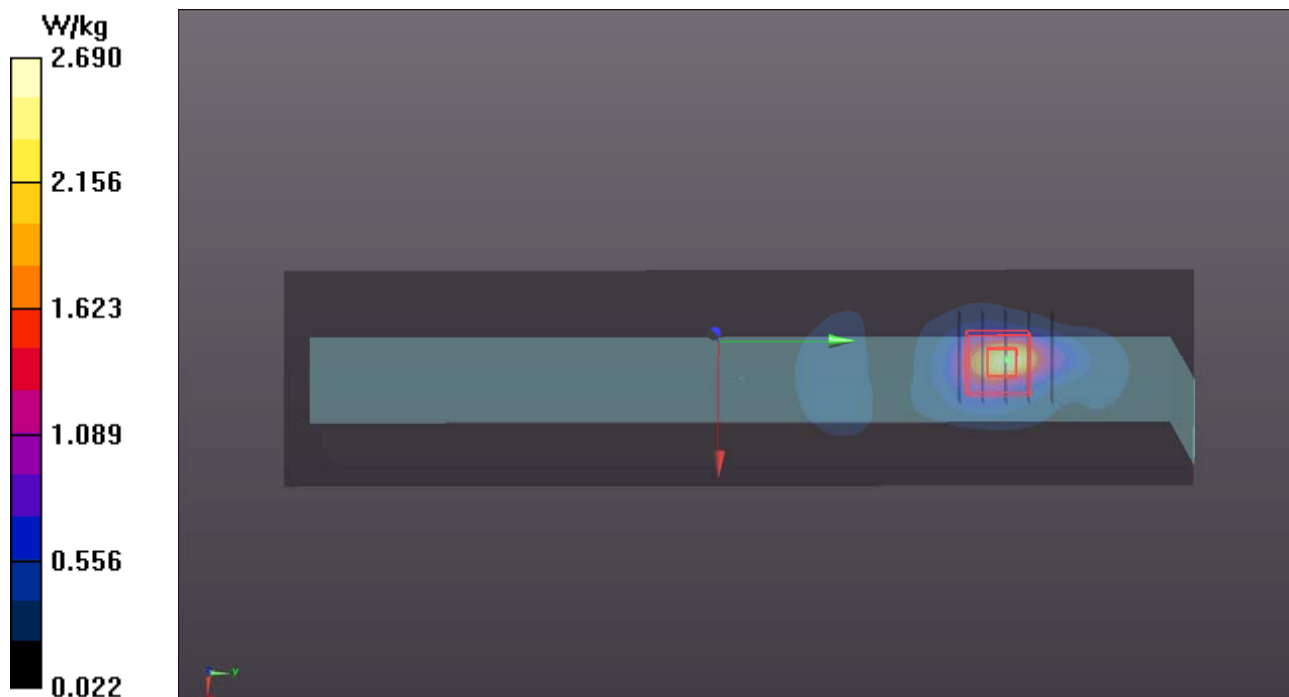

## P02 WCDMA IV\_RMC12.2K\_Left Side\_0cm\_Ch1312

**DUT: 170927C14**

Communication System: WCDMA; Frequency: 1712.4 MHz; Duty Cycle: 1:1

Medium: B16T20N1\_1028 Medium parameters used:  $f = 1712.4$  MHz;  $\sigma = 1.399$  S/m;  $\epsilon_r = 52.15$ ;  $\rho = 1000$  kg/m<sup>3</sup>

Ambient Temperature : 23.7 °C ; Liquid Temperature : 23.2 °C

DASY5 Configuration:

- Probe: EX3DV4 - SN3971; ConvF(8.51, 8.51, 8.51); Calibrated: 2017/03/24;
- Sensor-Surface: 1.4mm (Mechanical Surface Detection)
- Electronics: DAE4 Sn1431; Calibrated: 2017/03/20
- Phantom: ELI Phantom\_1245; Type: QDOVA;
- Measurement SW: DASY52, Version 52.8 (8); SEMCAD X Version 14.6.10 (7373)

- **Area Scan (51x211x1):** Interpolated grid: dx=1.500 mm, dy=1.500 mm

Maximum value of SAR (interpolated) = 1.97 W/kg

- **Zoom Scan (5x5x7)/Cube 0:** Measurement grid: dx=8mm, dy=8mm, dz=5mm

Reference Value = 34.23 V/m; Power Drift = -0.16 dB

Peak SAR (extrapolated) = 2.52 W/kg

**SAR(1 g) = 1.28 W/kg; SAR(10 g) = 0.646 W/kg**

Maximum value of SAR (measured) = 2.12 W/kg

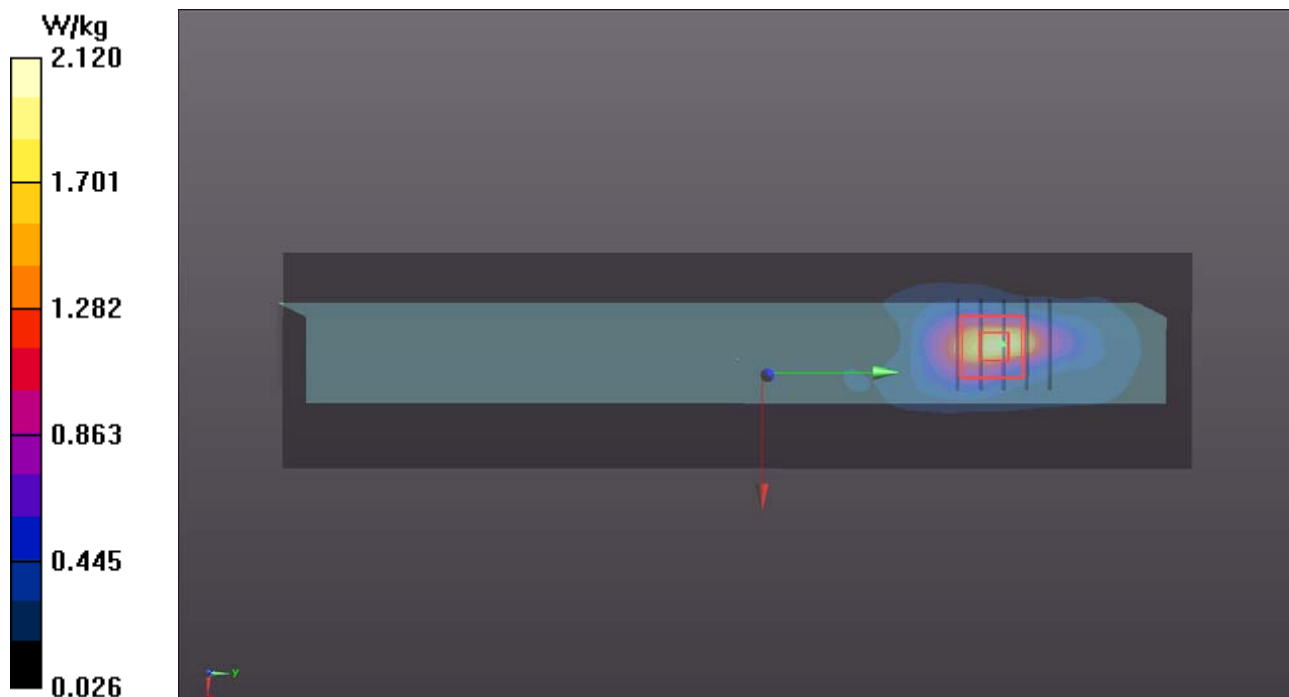

### P03 WCDMA V\_RMC12.2K\_Left Side\_0cm\_Ch4233

**DUT: 170927C14**

Communication System: WCDMA; Frequency: 846.6 MHz; Duty Cycle: 1:1

Medium: B07T10N1\_1028 Medium parameters used:  $f = 847$  MHz;  $\sigma = 1.029$  S/m;  $\epsilon_r = 57.163$ ;  $\rho = 1000$  kg/m<sup>3</sup>

Ambient Temperature : 23.7 °C ; Liquid Temperature : 23.2 °C

DASY5 Configuration:

- Probe: EX3DV4 - SN3971; ConvF(10.52, 10.52, 10.52); Calibrated: 2017/03/24;
- Sensor-Surface: 1.4mm (Mechanical Surface Detection)
- Electronics: DAE4 Sn1431; Calibrated: 2017/03/20
- Phantom: ELI Phantom\_1043; Type: QDOVA;
- Measurement SW: DASY52, Version 52.8 (8); SEMCAD X Version 14.6.10 (7373)

- **Area Scan (51x211x1):** Interpolated grid: dx=1.500 mm, dy=1.500 mm

Maximum value of SAR (interpolated) = 1.50 W/kg

- **Zoom Scan (5x5x7)/Cube 0:** Measurement grid: dx=8mm, dy=8mm, dz=5mm

Reference Value = 34.26 V/m; Power Drift = -0.15 dB

Peak SAR (extrapolated) = 2.62 W/kg

**SAR(1 g) = 1.06 W/kg; SAR(10 g) = 0.516 W/kg**

Maximum value of SAR (measured) = 2.04 W/kg

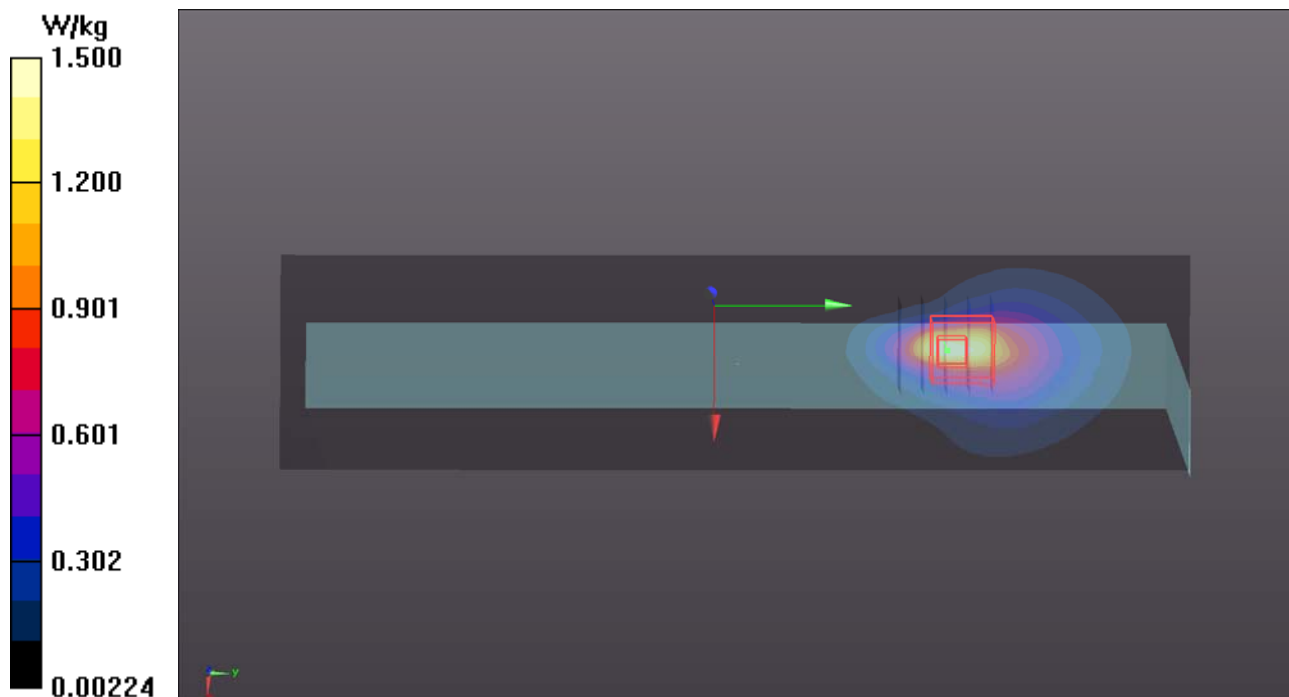

### P04 LTE 2\_QPSK20M\_Left Side\_0cm\_Ch18900\_1RB\_OS0

**DUT: 170927C14**

Communication System: LTE; Frequency: 1880 MHz; Duty Cycle: 1:1

Medium: B16T20N1\_1028 Medium parameters used:  $f = 1880$  MHz;  $\sigma = 1.563$  S/m;  $\epsilon_r = 51.654$ ;  $\rho = 1000$  kg/m<sup>3</sup>

Ambient Temperature : 23.7 °C ; Liquid Temperature : 23.2 °C

DASY5 Configuration:

- Probe: EX3DV4 - SN3971; ConvF(8.26, 8.26, 8.26); Calibrated: 2017/03/24;
- Sensor-Surface: 1.4mm (Mechanical Surface Detection)
- Electronics: DAE4 Sn1431; Calibrated: 2017/03/20
- Phantom: ELI Phantom\_1245; Type: QDOVA;
- Measurement SW: DASY52, Version 52.8 (8); SEMCAD X Version 14.6.10 (7373)

- **Area Scan (51x211x1):** Interpolated grid: dx=1.500 mm, dy=1.500 mm

Maximum value of SAR (interpolated) = 2.65 W/kg

- **Zoom Scan (5x5x7)/Cube 0:** Measurement grid: dx=8mm, dy=8mm, dz=5mm

Reference Value = 37.45 V/m; Power Drift = -0.15 dB

Peak SAR (extrapolated) = 3.42 W/kg

**SAR(1 g) = 1.7 W/kg; SAR(10 g) = 0.822 W/kg**

Maximum value of SAR (measured) = 2.81 W/kg

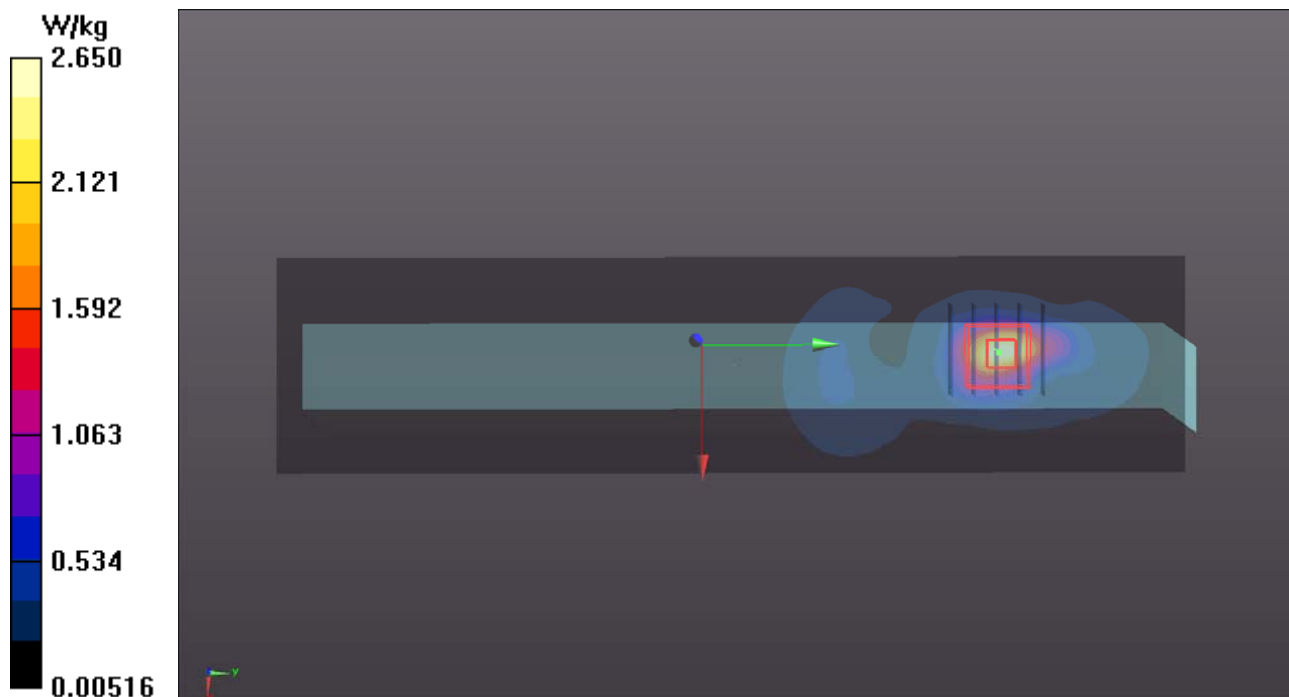

### P05 LTE 4\_QPSK20M\_Left Side\_0cm\_Ch20175\_1RB\_OS0

**DUT: 170927C14**

Communication System: LTE; Frequency: 1732.5 MHz; Duty Cycle: 1:1

Medium: B16T20N1\_1028 Medium parameters used:  $f = 1732.5$  MHz;  $\sigma = 1.417$  S/m;  $\epsilon_r = 52.082$ ;  $\rho = 1000$  kg/m<sup>3</sup>

Ambient Temperature : 23.7 °C ; Liquid Temperature : 23.2 °C

DASY5 Configuration:

- Probe: EX3DV4 - SN3971; ConvF(8.51, 8.51, 8.51); Calibrated: 2017/03/24;
- Sensor-Surface: 1.4mm (Mechanical Surface Detection)
- Electronics: DAE4 Sn1431; Calibrated: 2017/03/20
- Phantom: ELI Phantom\_1245; Type: QDOVA;
- Measurement SW: DASY52, Version 52.8 (8); SEMCAD X Version 14.6.10 (7373)

- **Area Scan (51x211x1):** Interpolated grid: dx=1.500 mm, dy=1.500 mm

Maximum value of SAR (interpolated) = 2.17 W/kg

- **Zoom Scan (5x5x7)/Cube 0:** Measurement grid: dx=8mm, dy=8mm, dz=5mm

Reference Value = 36.01 V/m; Power Drift = -0.12 dB

Peak SAR (extrapolated) = 2.87 W/kg

**SAR(1 g) = 1.47 W/kg; SAR(10 g) = 0.746 W/kg**

Maximum value of SAR (measured) = 2.43 W/kg

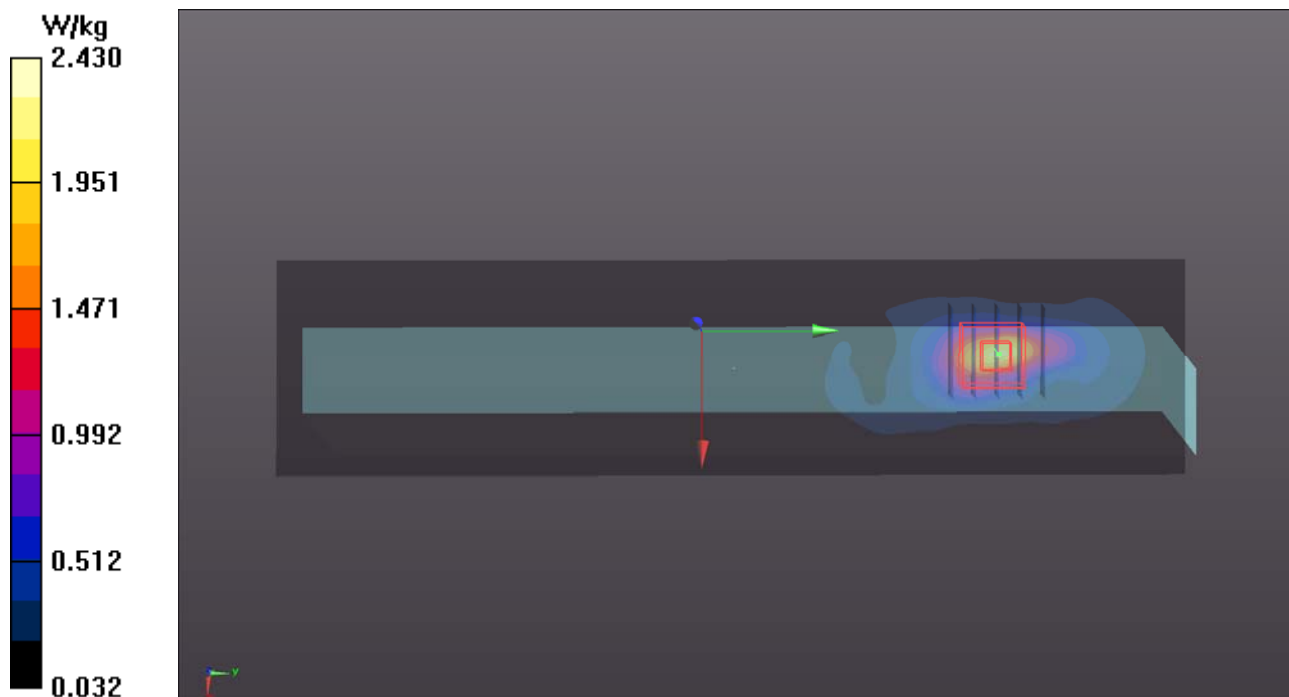



### P06 LTE 5\_QPSK10M\_Left Side\_0cm\_Ch20600\_1RB\_OS0

**DUT: 170927C14**

Communication System: LTE; Frequency: 844 MHz; Duty Cycle: 1:1

Medium: B07T10N1\_1028 Medium parameters used:  $f = 844 \text{ MHz}$ ;  $\sigma = 1.026 \text{ S/m}$ ;  $\epsilon_r = 57.19$ ;  $\rho = 1000 \text{ kg/m}^3$

Ambient Temperature :  $23.8 \text{ }^\circ\text{C}$  ; Liquid Temperature :  $23.3 \text{ }^\circ\text{C}$

DASY5 Configuration:

- Probe: EX3DV4 - SN3971; ConvF(10.52, 10.52, 10.52); Calibrated: 2017/03/24;
- Sensor-Surface: 1.4mm (Mechanical Surface Detection)
- Electronics: DAE4 Sn1431; Calibrated: 2017/03/20
- Phantom: ELI Phantom\_1043; Type: QDOVA;
- Measurement SW: DASY52, Version 52.8 (8); SEMCAD X Version 14.6.10 (7373)

- **Area Scan (51x211x1):** Interpolated grid:  $dx=1.500 \text{ mm}$ ,  $dy=1.500 \text{ mm}$

Maximum value of SAR (interpolated) =  $2.00 \text{ W/kg}$

- **Zoom Scan (5x5x7)/Cube 0:** Measurement grid:  $dx=8\text{mm}$ ,  $dy=8\text{mm}$ ,  $dz=5\text{mm}$

Reference Value =  $40.28 \text{ V/m}$ ; Power Drift =  $-0.12 \text{ dB}$

Peak SAR (extrapolated) =  $2.82 \text{ W/kg}$

**SAR(1 g) =  $1.14 \text{ W/kg}$ ; SAR(10 g) =  $0.553 \text{ W/kg}$**

Maximum value of SAR (measured) =  $2.21 \text{ W/kg}$

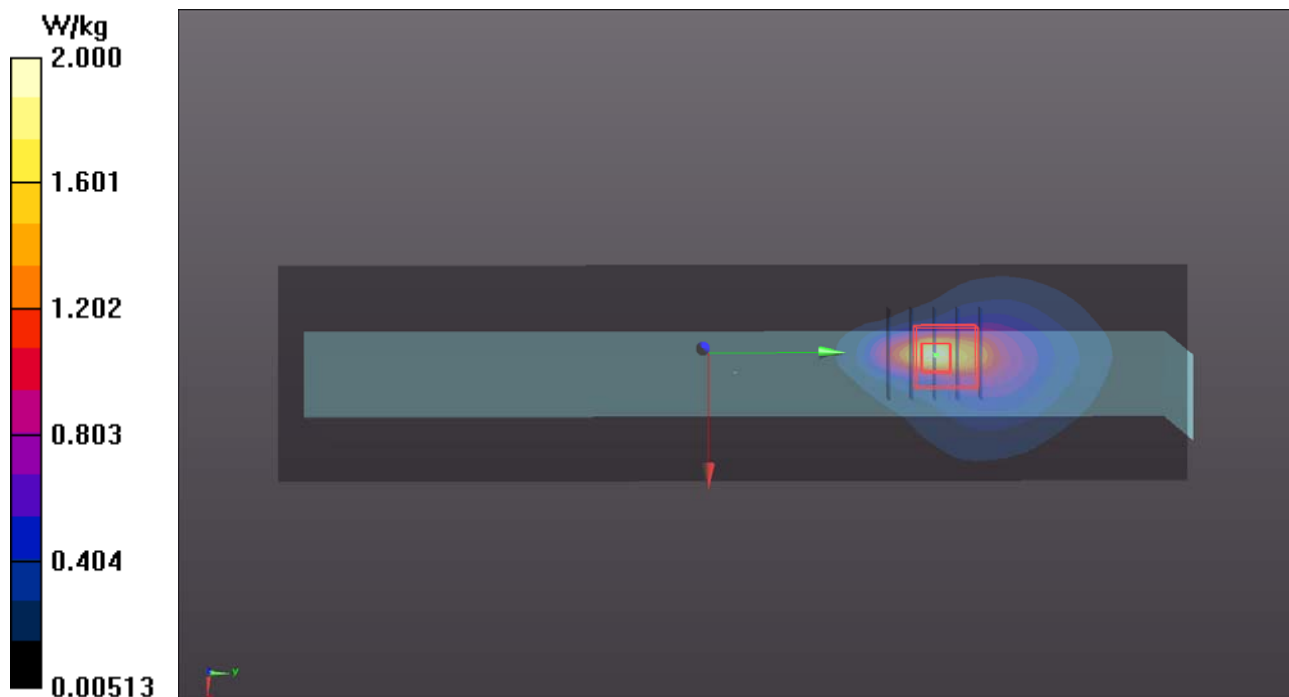

### P07 LTE 7\_QPSK20M\_Left Side\_0cm\_Ch21100\_1RB\_OS0

**DUT: 170927C14**

Communication System: LTE; Frequency: 2535 MHz; Duty Cycle: 1:1

Medium: B19T27N5\_1028 Medium parameters used:  $f = 2535$  MHz;  $\sigma = 2.111$  S/m;  $\epsilon_r = 50.85$ ;  $\rho = 1000$  kg/m<sup>3</sup>

Ambient Temperature : 23.7 °C ; Liquid Temperature : 23.2 °C

DASY5 Configuration:

- Probe: EX3DV4 - SN3971; ConvF(7.32, 7.32, 7.32); Calibrated: 2017/03/24;
- Sensor-Surface: 1.4mm (Mechanical Surface Detection)
- Electronics: DAE4 Sn1431; Calibrated: 2017/03/20
- Phantom: ELI Phantom\_1043; Type: QDOVA;
- Measurement SW: DASY52, Version 52.8 (8); SEMCAD X Version 14.6.10 (7373)

- **Area Scan (51x261x1):** Interpolated grid: dx=1.200 mm, dy=1.200 mm

Maximum value of SAR (interpolated) = 5.57 W/kg

- **Zoom Scan (5x5x7)/Cube 0:** Measurement grid: dx=8mm, dy=8mm, dz=5mm

Reference Value = 45.64 V/m; Power Drift = -0.18 dB

Peak SAR (extrapolated) = 7.80 W/kg

**SAR(1 g) = 2.92 W/kg; SAR(10 g) = 1.11 W/kg**

Maximum value of SAR (measured) = 6.12 W/kg

- **Zoom Scan (5x5x7)/Cube 1:** Measurement grid: dx=8mm, dy=8mm, dz=5mm

Reference Value = 45.64 V/m; Power Drift = -0.18 dB

Peak SAR (extrapolated) = 4.68 W/kg

**SAR(1 g) = 1.99 W/kg; SAR(10 g) = 0.743 W/kg**

Maximum value of SAR (measured) = 3.67 W/kg

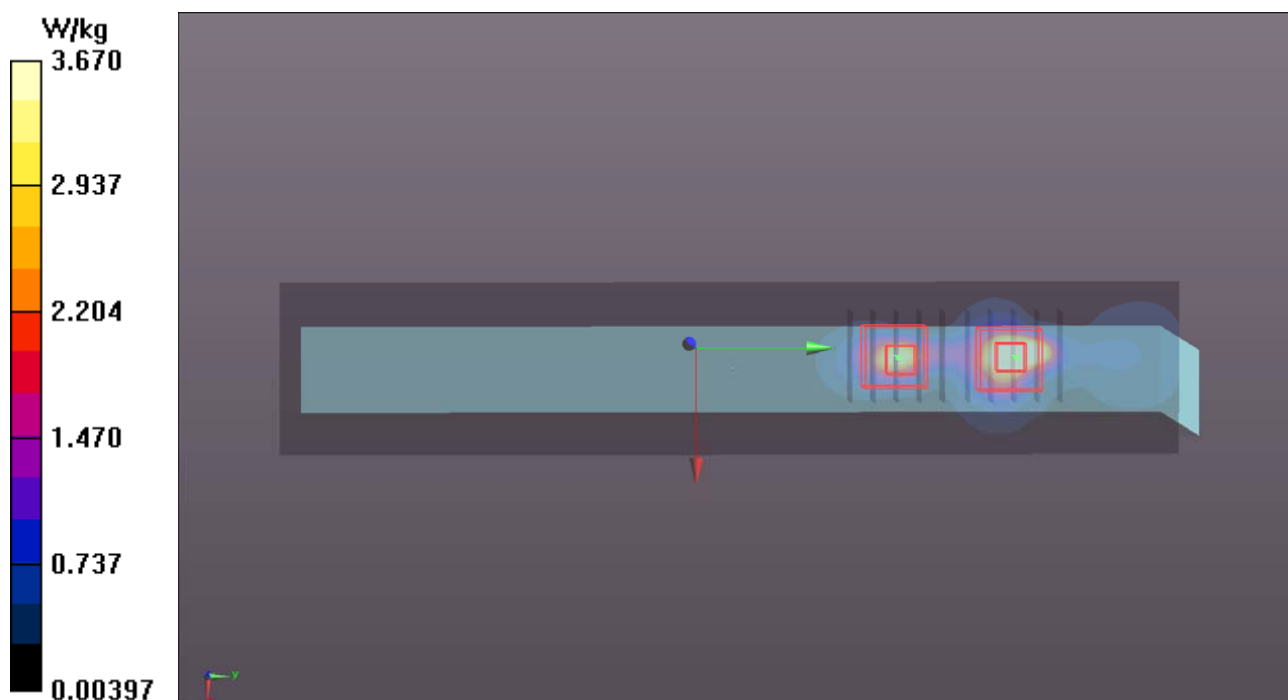

### P08 LTE 12\_QPSK10M\_Left Side\_0cm\_Ch23095\_1RB\_OS0

**DUT: 170927C14**

Communication System: LTE; Frequency: 707.5 MHz; Duty Cycle: 1:1

Medium: B06T09N1\_1028 Medium parameters used:  $f = 707.5 \text{ MHz}$ ;  $\sigma = 0.92 \text{ S/m}$ ;  $\epsilon_r = 56.834$ ;  $\rho = 1000 \text{ kg/m}^3$

Ambient Temperature : 23.8 °C ; Liquid Temperature : 23.3 °C

DASY5 Configuration:

- Probe: EX3DV4 - SN3971; ConvF(10.61, 10.61, 10.61); Calibrated: 2017/03/24;
- Sensor-Surface: 1.4mm (Mechanical Surface Detection)
- Electronics: DAE4 Sn1431; Calibrated: 2017/03/20
- Phantom: ELI Phantom\_1043; Type: QDOVA;
- Measurement SW: DASY52, Version 52.8 (8); SEMCAD X Version 14.6.10 (7373)

- **Area Scan (51x211x1):** Interpolated grid:  $dx=1.500 \text{ mm}$ ,  $dy=1.500 \text{ mm}$

Maximum value of SAR (interpolated) = 1.26 W/kg

- **Zoom Scan (5x5x7)/Cube 0:** Measurement grid:  $dx=8\text{mm}$ ,  $dy=8\text{mm}$ ,  $dz=5\text{mm}$

Reference Value = 34.09 V/m; Power Drift = -0.13 dB

Peak SAR (extrapolated) = 1.83 W/kg

**SAR(1 g) = 0.728 W/kg; SAR(10 g) = 0.357 W/kg**

Maximum value of SAR (measured) = 1.43 W/kg

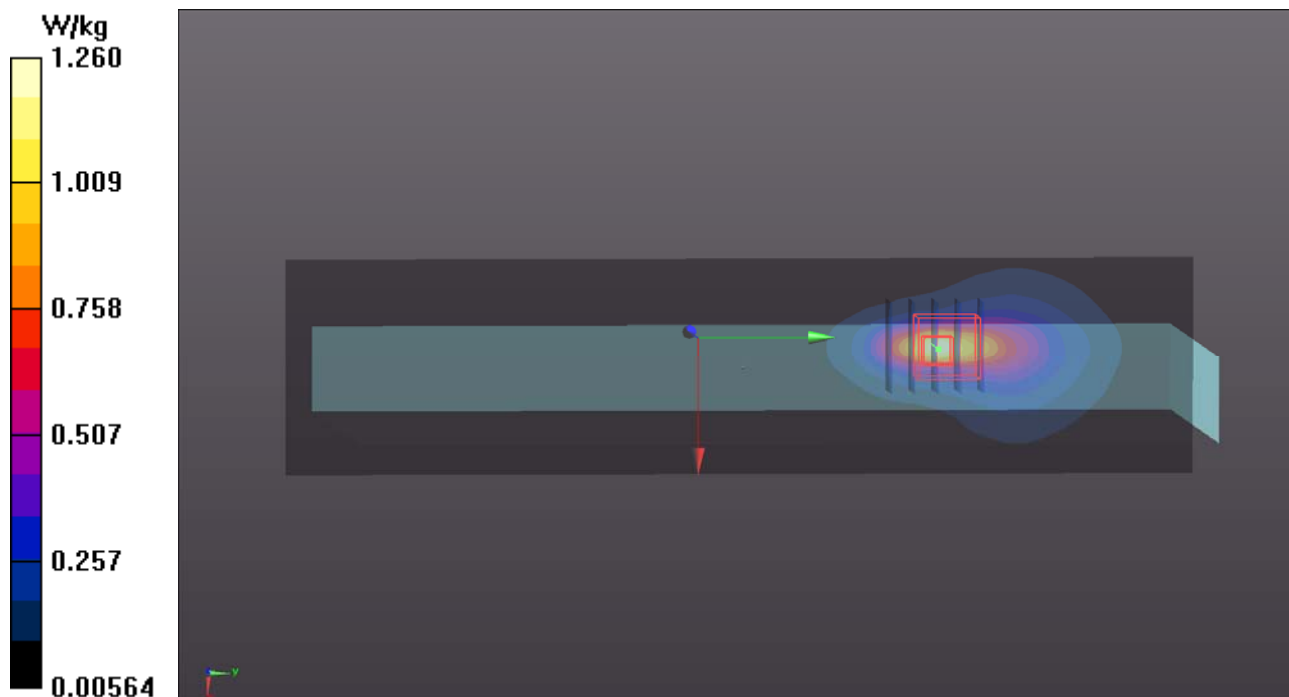

### P09 LTE 13\_QPSK10M\_Left Side\_0cm\_Ch23230\_1RB\_OS0

**DUT: 170927C14**

Communication System: LTE; Frequency: 782 MHz; Duty Cycle: 1:1

Medium: B06T09N1\_1028 Medium parameters used:  $f = 782 \text{ MHz}$ ;  $\sigma = 0.99 \text{ S/m}$ ;  $\epsilon_r = 56.114$ ;  $\rho = 1000 \text{ kg/m}^3$

Ambient Temperature :  $23.7 \text{ }^\circ\text{C}$  ; Liquid Temperature :  $23.2 \text{ }^\circ\text{C}$

DASY5 Configuration:

- Probe: EX3DV4 - SN3971; ConvF(10.61, 10.61, 10.61); Calibrated: 2017/03/24;
- Sensor-Surface: 1.4mm (Mechanical Surface Detection)
- Electronics: DAE4 Sn1431; Calibrated: 2017/03/20
- Phantom: ELI Phantom\_1043; Type: QDOVA;
- Measurement SW: DASY52, Version 52.8 (8); SEMCAD X Version 14.6.10 (7373)

- **Area Scan (51x211x1):** Interpolated grid:  $dx=1.500 \text{ mm}$ ,  $dy=1.500 \text{ mm}$

Maximum value of SAR (interpolated) =  $0.947 \text{ W/kg}$

- **Zoom Scan (5x5x7)/Cube 0:** Measurement grid:  $dx=8\text{mm}$ ,  $dy=8\text{mm}$ ,  $dz=5\text{mm}$

Reference Value =  $28.66 \text{ V/m}$ ; Power Drift =  $-0.16 \text{ dB}$

Peak SAR (extrapolated) =  $1.28 \text{ W/kg}$

**SAR(1 g) =  $0.529 \text{ W/kg}$ ; SAR(10 g) =  $0.255 \text{ W/kg}$**

Maximum value of SAR (measured) =  $0.939 \text{ W/kg}$

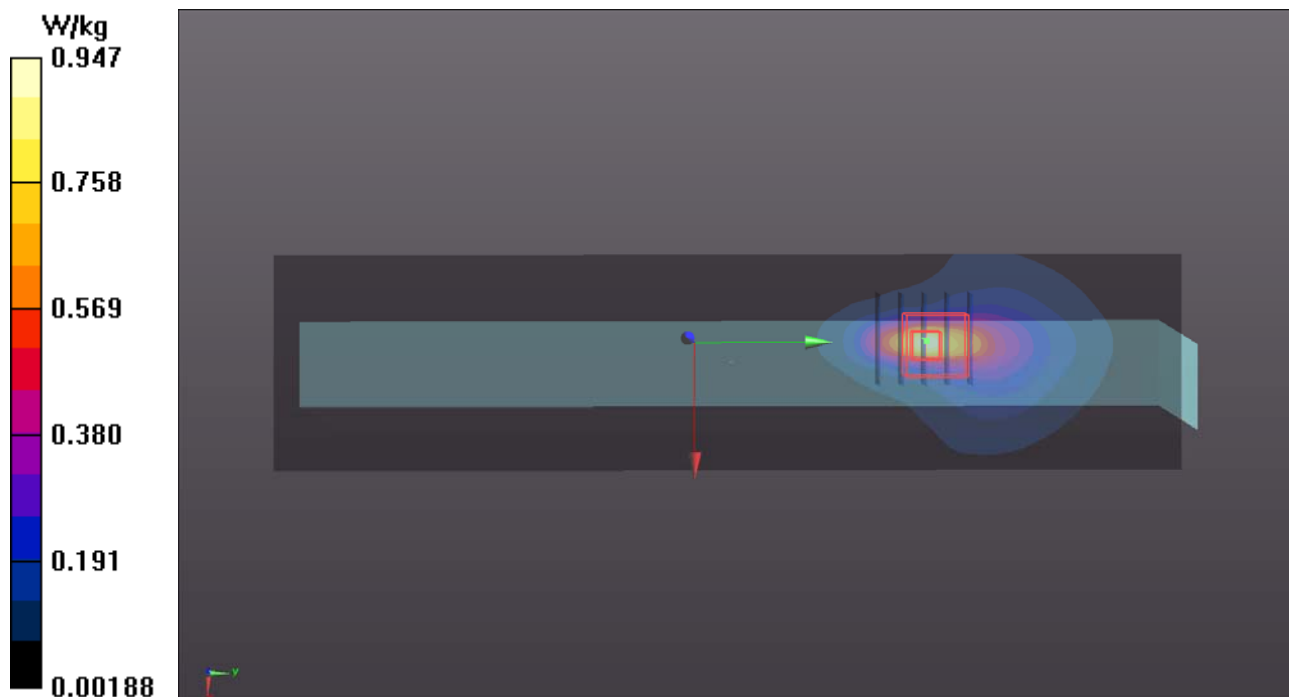

### P10 LTE 25\_QPSK20M\_Left Side\_0cm\_Ch26590\_1RB\_OS0

**DUT: 170927C14**

Communication System: LTE; Frequency: 1905 MHz; Duty Cycle: 1:1

Medium: B16T20N1\_1028 Medium parameters used:  $f = 1905$  MHz;  $\sigma = 1.589$  S/m;  $\epsilon_r = 51.601$ ;  $\rho = 1000$  kg/m<sup>3</sup>

Ambient Temperature : 23.7 °C ; Liquid Temperature : 23.2 °C

DASY5 Configuration:

- Probe: EX3DV4 - SN3971; ConvF(8.26, 8.26, 8.26); Calibrated: 2017/03/24;
- Sensor-Surface: 1.4mm (Mechanical Surface Detection)
- Electronics: DAE4 Sn1431; Calibrated: 2017/03/20
- Phantom: ELI Phantom\_1245; Type: QDOVA;
- Measurement SW: DASY52, Version 52.8 (8); SEMCAD X Version 14.6.10 (7373)

- **Area Scan (51x211x1):** Interpolated grid: dx=1.500 mm, dy=1.500 mm

Maximum value of SAR (interpolated) = 2.46 W/kg

- **Zoom Scan (5x5x7)/Cube 0:** Measurement grid: dx=8mm, dy=8mm, dz=5mm

Reference Value = 35.41 V/m; Power Drift = -0.18 dB

Peak SAR (extrapolated) = 3.22 W/kg

**SAR(1 g) = 1.55 W/kg; SAR(10 g) = 0.746 W/kg**

Maximum value of SAR (measured) = 2.58 W/kg

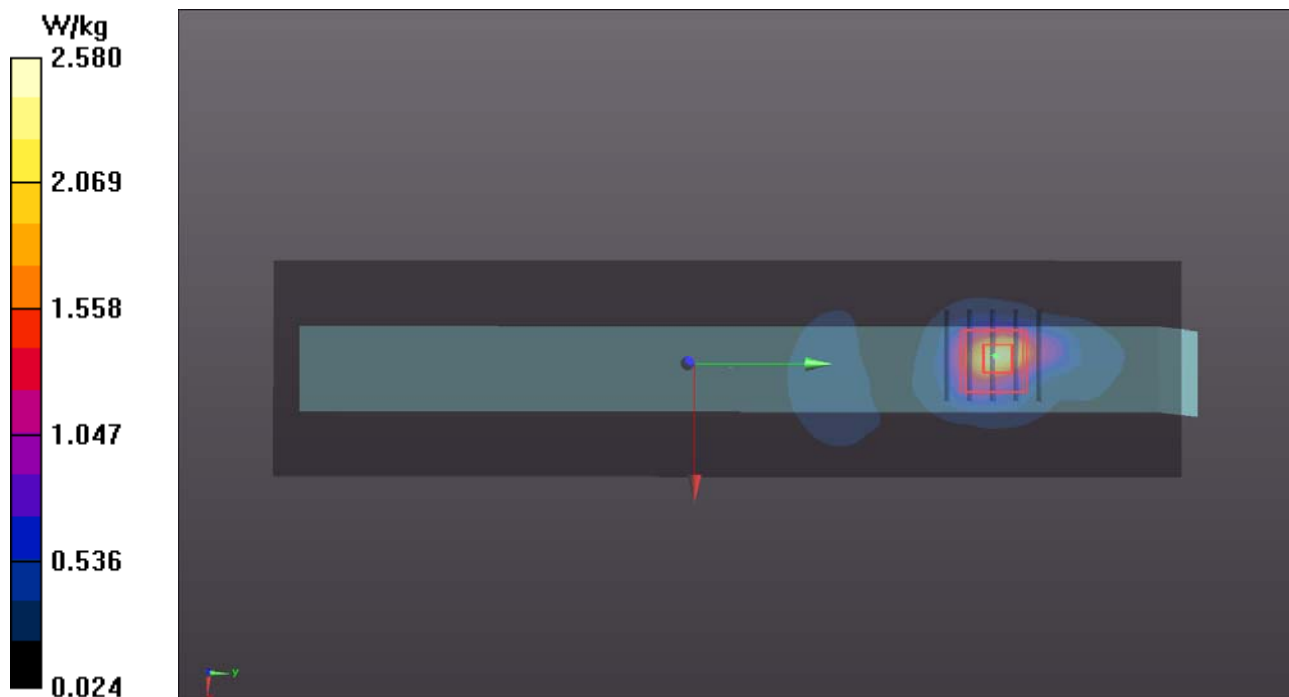

### P11 LTE 26\_QPSK15M\_Left Side\_0cm\_Ch26965\_1RB\_OS0

**DUT: 170927C14**

Communication System: LTE; Frequency: 841.5 MHz; Duty Cycle: 1:1

Medium: B07T10N1\_1028 Medium parameters used:  $f = 841.5$  MHz;  $\sigma = 1.024$  S/m;  $\epsilon_r = 57.218$ ;  $\rho = 1000$  kg/m<sup>3</sup>

Ambient Temperature : 23.7 °C ; Liquid Temperature : 23.2 °C

DASY5 Configuration:

- Probe: EX3DV4 - SN3971; ConvF(10.52, 10.52, 10.52); Calibrated: 2017/03/24;
- Sensor-Surface: 1.4mm (Mechanical Surface Detection)
- Electronics: DAE4 Sn1431; Calibrated: 2017/03/20
- Phantom: ELI Phantom\_1043; Type: QDOVA;
- Measurement SW: DASY52, Version 52.8 (8); SEMCAD X Version 14.6.10 (7373)

- **Area Scan (51x211x1):** Interpolated grid: dx=1.500 mm, dy=1.500 mm

Maximum value of SAR (interpolated) = 1.67 W/kg

- **Zoom Scan (5x5x7)/Cube 0:** Measurement grid: dx=8mm, dy=8mm, dz=5mm

Reference Value = 36.91 V/m; Power Drift = -0.15 dB

Peak SAR (extrapolated) = 2.34 W/kg

**SAR(1 g) = 0.954 W/kg; SAR(10 g) = 0.467 W/kg**

Maximum value of SAR (measured) = 1.85 W/kg

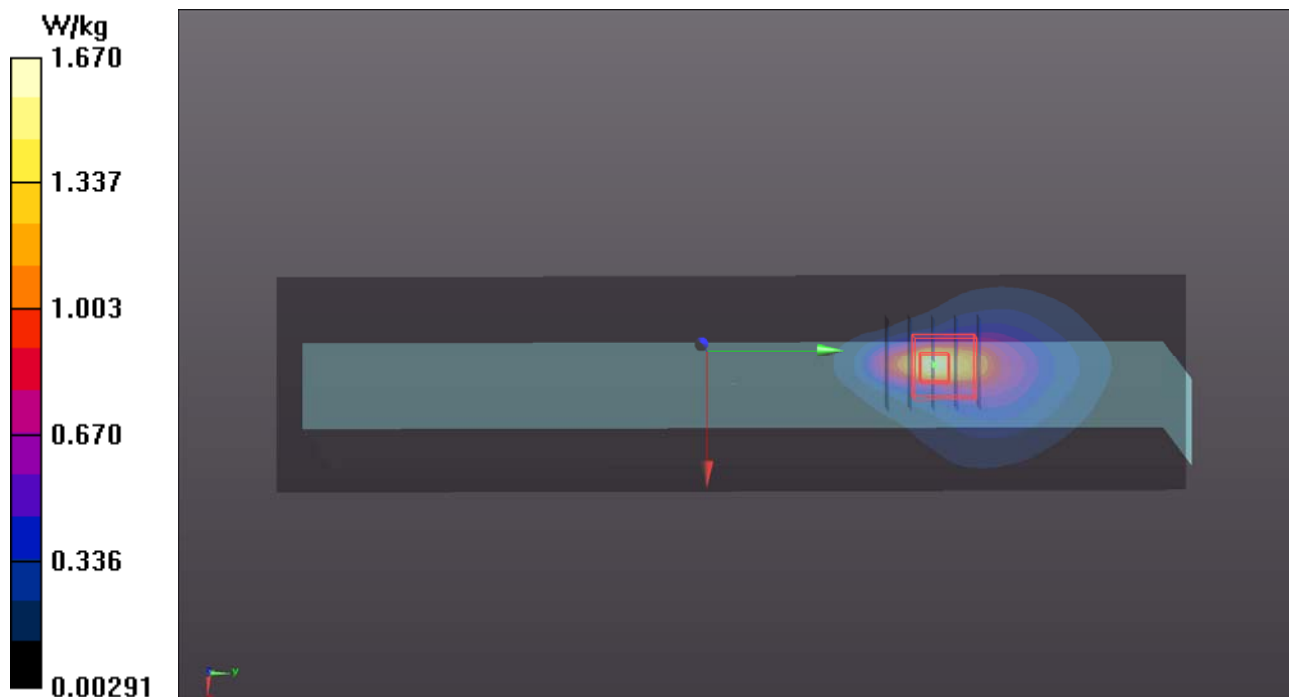

### P12 LTE 30\_QPSK10M\_Left Side\_0cm\_Ch27710\_1RB\_OS0

**DUT: 170927C14**

Communication System: LTE; Frequency: 2310 MHz; Duty Cycle: 1:1

Medium: B19T27N5\_1028 Medium parameters used:  $f = 2310$  MHz;  $\sigma = 1.864$  S/m;  $\epsilon_r = 51.477$ ;  $\rho = 1000$  kg/m<sup>3</sup>

Ambient Temperature : 23.6 °C ; Liquid Temperature : 23.2 °C

DASY5 Configuration:

- Probe: EX3DV4 - SN3971; ConvF(7.85, 7.85, 7.85); Calibrated: 2017/03/24;
- Sensor-Surface: 1.4mm (Mechanical Surface Detection)
- Electronics: DAE4 Sn1431; Calibrated: 2017/03/20
- Phantom: ELI Phantom\_1043; Type: QDOVA;
- Measurement SW: DASY52, Version 52.8 (8); SEMCAD X Version 14.6.10 (7373)

- **Area Scan (51x261x1):** Interpolated grid: dx=1.200 mm, dy=1.200 mm

Maximum value of SAR (interpolated) = 2.02 W/kg

- **Zoom Scan (5x5x7)/Cube 0:** Measurement grid: dx=8mm, dy=8mm, dz=5mm

Reference Value = 28.98 V/m; Power Drift = -0.17 dB

Peak SAR (extrapolated) = 2.55 W/kg

**SAR(1 g) = 1.08 W/kg; SAR(10 g) = 0.459 W/kg**

Maximum value of SAR (measured) = 2.03 W/kg

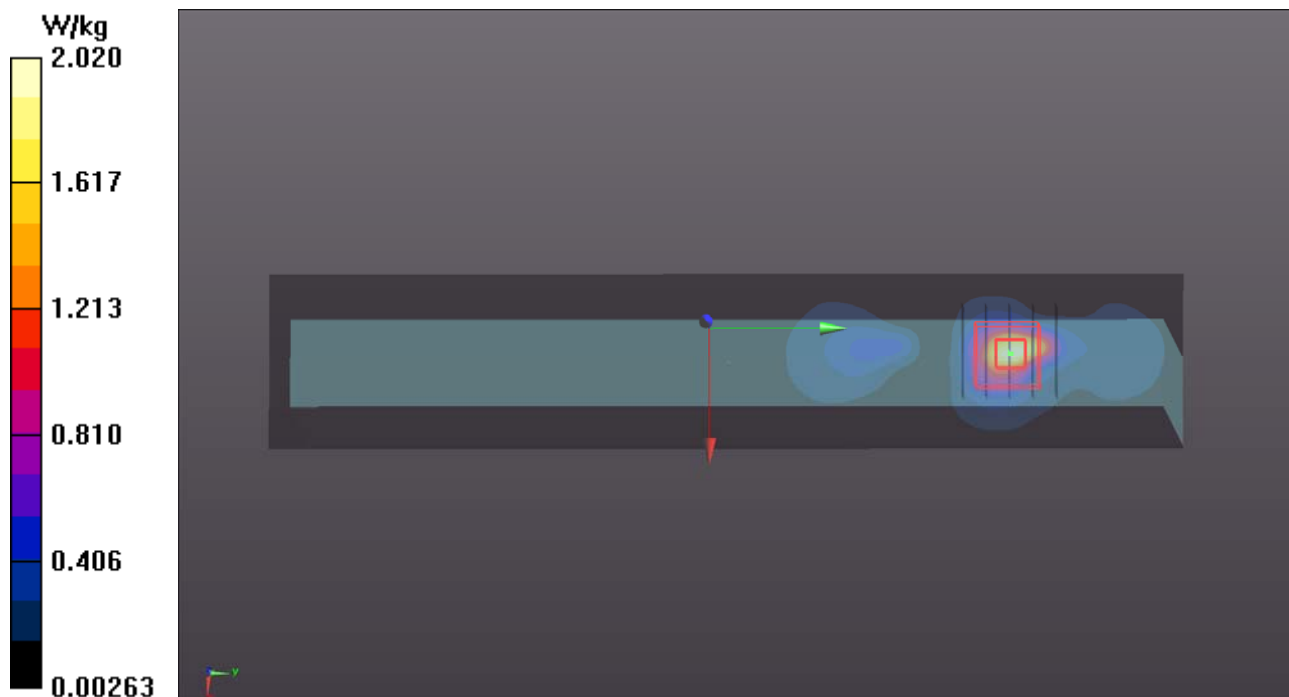

### P13 LTE 41\_QPSK20M\_Left Side\_0cm\_Ch40620\_1RB\_OS0

**DUT: 170927C14**

Communication System: LTE TDD CF0; Frequency: 2593 MHz; Duty Cycle: 1:1.58

Medium: B19T27N5\_1028 Medium parameters used:  $f = 2593$  MHz;  $\sigma = 2.179$  S/m;  $\epsilon_r = 50.665$ ;  $\rho = 1000$  kg/m<sup>3</sup>

Ambient Temperature : 23.7 °C ; Liquid Temperature : 23.2 °C

DASY5 Configuration:

- Probe: EX3DV4 - SN3971; ConvF(7.32, 7.32, 7.32); Calibrated: 2017/03/24;
- Sensor-Surface: 1.4mm (Mechanical Surface Detection)
- Electronics: DAE4 Sn1431; Calibrated: 2017/03/20
- Phantom: ELI Phantom\_1043; Type: QDOVA;
- Measurement SW: DASY52, Version 52.8 (8); SEMCAD X Version 14.6.10 (7373)

- **Area Scan (51x261x1):** Interpolated grid: dx=1.200 mm, dy=1.200 mm

Maximum value of SAR (interpolated) = 4.09 W/kg

- **Zoom Scan (5x5x7)/Cube 0:** Measurement grid: dx=8mm, dy=8mm, dz=5mm

Reference Value = 39.06 V/m; Power Drift = -0.10 dB

Peak SAR (extrapolated) = 5.75 W/kg

**SAR(1 g) = 2.16 W/kg; SAR(10 g) = 0.837 W/kg**

Maximum value of SAR (measured) = 4.45 W/kg

- **Zoom Scan (5x5x7)/Cube 1:** Measurement grid: dx=8mm, dy=8mm, dz=5mm

Reference Value = 39.06 V/m; Power Drift = -0.10 dB

Peak SAR (extrapolated) = 5.09 W/kg

**SAR(1 g) = 2.07 W/kg; SAR(10 g) = 0.762 W/kg**

Maximum value of SAR (measured) = 4.02 W/kg

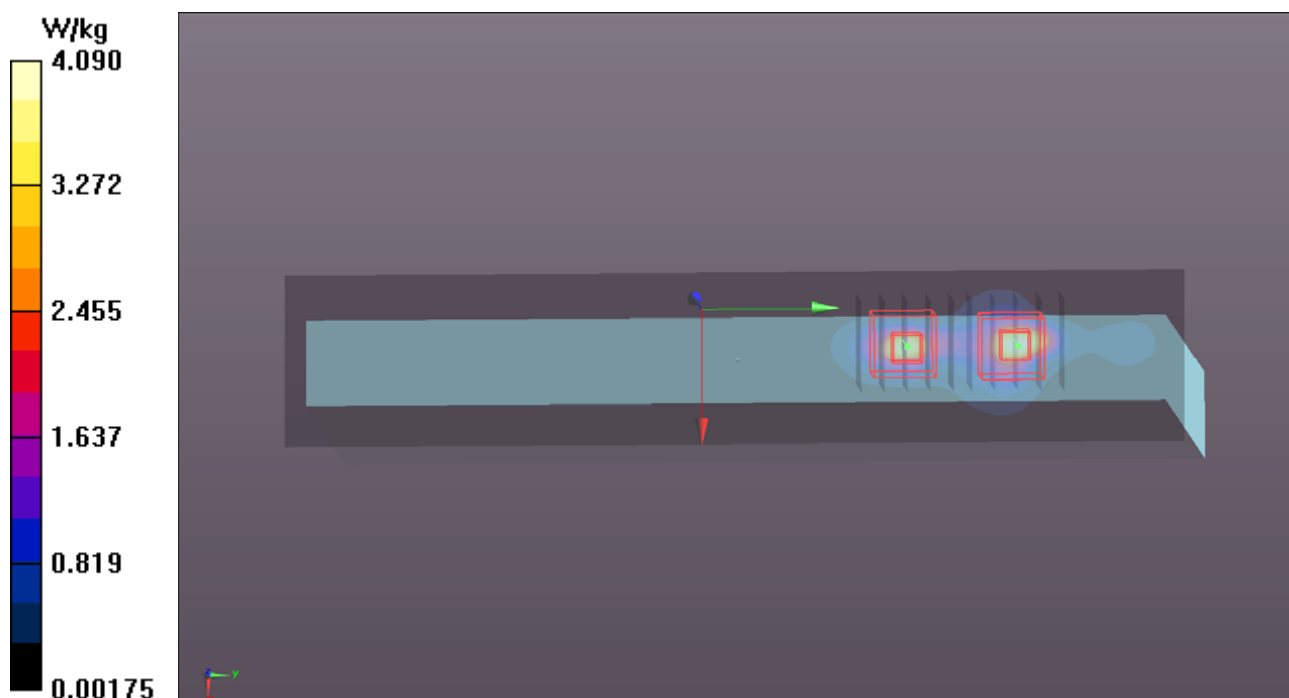



### P14 2.4G WLAN\_802.11b\_Right Side\_0cm\_Ch6\_ANT 0+1

**DUT: 170926C17**

Communication System: WLAN\_2.4G; Frequency: 2437 MHz; Duty Cycle: 1:1

Medium: B19T27N2\_1028 Medium parameters used:  $f = 2437$  MHz;  $\sigma = 2.001$  S/m;  $\epsilon_r = 51.67$ ;  $\rho = 1000$  kg/m<sup>3</sup>

Ambient Temperature : 23.7 °C ; Liquid Temperature : 23.3 °C

DASY5 Configuration:

- Probe: EX3DV4 - SN7375; ConvF(7.33, 7.33, 7.33); Calibrated: 2016/12/08;
- Sensor-Surface: 1.4mm (Mechanical Surface Detection)
- Electronics: DAE3 Sn579; Calibrated: 2017/08/17
- Phantom: ELI Phantom\_1206; Type: QDOVA;
- Measurement SW: DASY52, Version 52.8 (8); SEMCAD X Version 14.6.10 (7373)

- **Area Scan (91x271x1):** Interpolated grid: dx=1.200 mm, dy=1.200 mm

Maximum value of SAR (interpolated) = 1.23 W/kg

- **Zoom Scan (5x5x7)/Cube 0:** Measurement grid: dx=8mm, dy=8mm, dz=5mm

Reference Value = 23.49 V/m; Power Drift = -0.09 dB

Peak SAR (extrapolated) = 6.67 W/kg

**SAR(1 g) = 2.82 W/kg; SAR(10 g) = 1.03 W/kg**

Maximum value of SAR (measured) = 4.14 W/kg

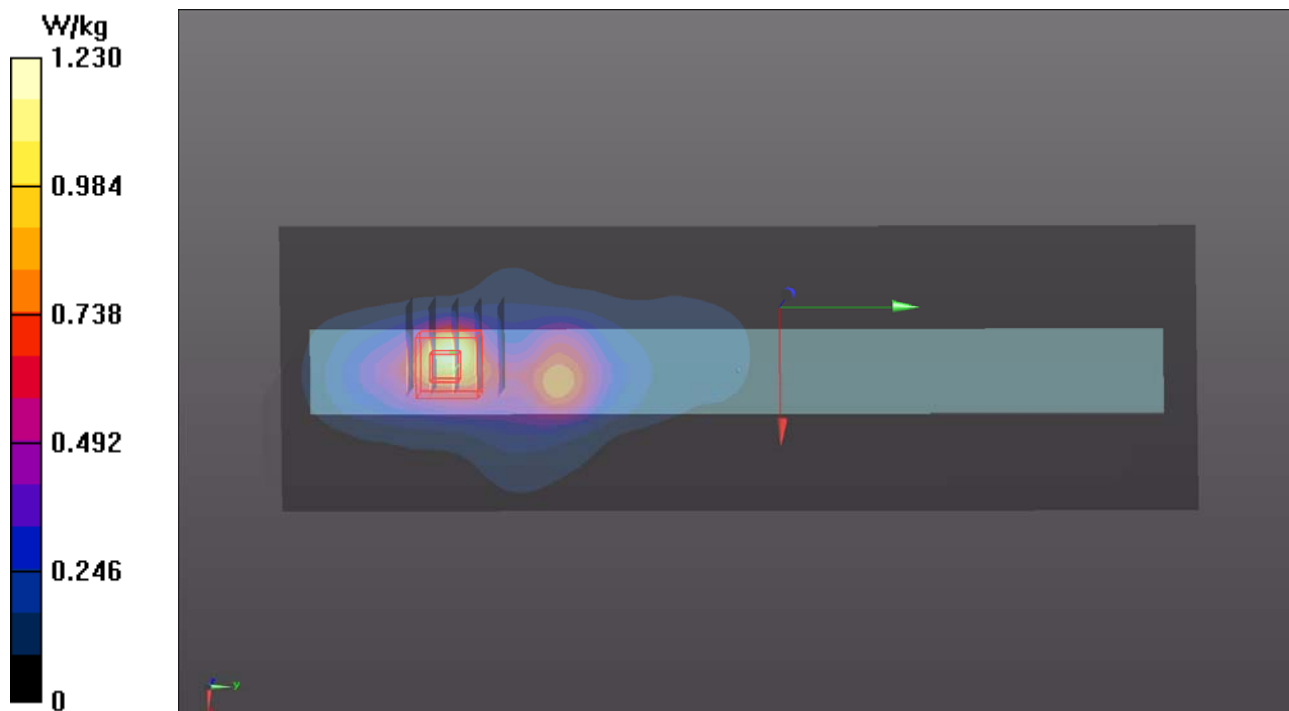

### P15 5.3G WLAN\_802.11n HT40\_Right Side\_0cm\_Ch54\_ANT 0+1

**DUT: 170926C17**

Communication System: WLAN\_5G; Frequency: 5270 MHz; Duty Cycle: 1:1

Medium: B34T60N1\_1028 Medium parameters used:  $f = 5270$  MHz;  $\sigma = 5.41$  S/m;  $\epsilon_r = 49.131$ ;  $\rho = 1000$  kg/m<sup>3</sup>

Ambient Temperature : 23.8 °C ; Liquid Temperature : 23.3 °C

DASY5 Configuration:

- Probe: EX3DV4 - SN7375; ConvF(4.57, 4.57, 4.57); Calibrated: 2016/12/08;
- Sensor-Surface: 1.4mm (Mechanical Surface Detection)
- Electronics: DAE3 Sn579; Calibrated: 2017/08/17
- Phantom: ELI Phantom\_1206; Type: QDOVA;
- Measurement SW: DASY52, Version 52.8 (8); SEMCAD X Version 14.6.10 (7373)

- **Area Scan (101x321x1):** Interpolated grid: dx=1.000 mm, dy=1.000 mm

Maximum value of SAR (interpolated) = 1.82 W/kg

- **Zoom Scan (6x6x12)/Cube 0:** Measurement grid: dx=5mm, dy=5mm, dz=2mm

Reference Value = 17.31 V/m; Power Drift = 0.04 dB

Peak SAR (extrapolated) = 3.67 W/kg

**SAR(1 g) = 0.912 W/kg; SAR(10 g) = 0.324 W/kg**

Maximum value of SAR (measured) = 2.04 W/kg

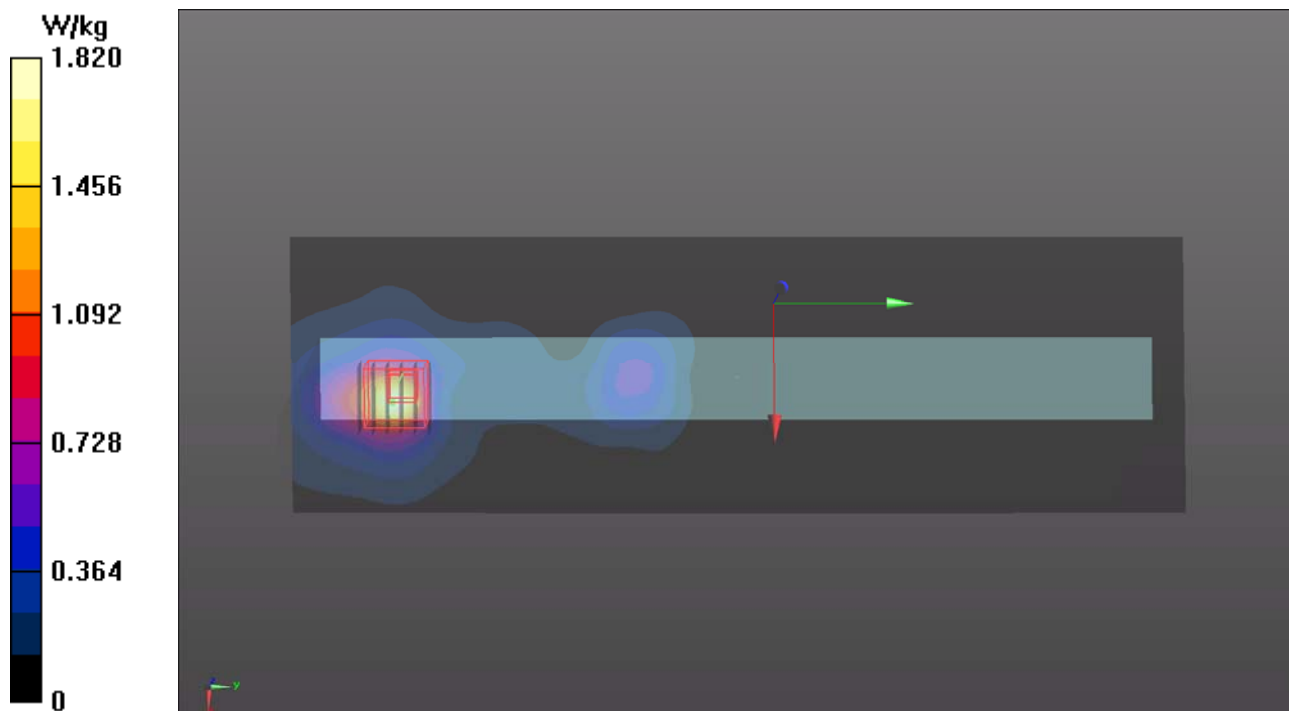

### P16 5.6G WLAN\_802.11n HT40\_Top Side\_0cm\_Ch134\_ANT 0+1

**DUT: 170926C17**

Communication System: WLAN\_5G; Frequency: 5670 MHz; Duty Cycle: 1:1

Medium: B34T60N1\_1028 Medium parameters used:  $f = 5670$  MHz;  $\sigma = 5.926$  S/m;  $\epsilon_r = 48.261$ ;  $\rho = 1000$  kg/m<sup>3</sup>

Ambient Temperature : 23.8 °C ; Liquid Temperature : 23.3 °C

DASY5 Configuration:

- Probe: EX3DV4 - SN7375; ConvF(3.99, 3.99, 3.99); Calibrated: 2016/12/08;
- Sensor-Surface: 1.4mm (Mechanical Surface Detection)
- Electronics: DAE3 Sn579; Calibrated: 2017/08/17
- Phantom: ELI Phantom\_1206; Type: QDOVA;
- Measurement SW: DASY52, Version 52.8 (8); SEMCAD X Version 14.6.10 (7373)

- **Area Scan (101x261x1):** Interpolated grid: dx=1.000 mm, dy=1.000 mm

Maximum value of SAR (interpolated) = 2.37 W/kg

- **Zoom Scan (6x6x12)/Cube 0:** Measurement grid: dx=5mm, dy=5mm, dz=2mm

Reference Value = 16.33 V/m; Power Drift = 0.08 dB

Peak SAR (extrapolated) = 6.45 W/kg

**SAR(1 g) = 1.57 W/kg; SAR(10 g) = 0.530 W/kg**

Maximum value of SAR (measured) = 3.65 W/kg

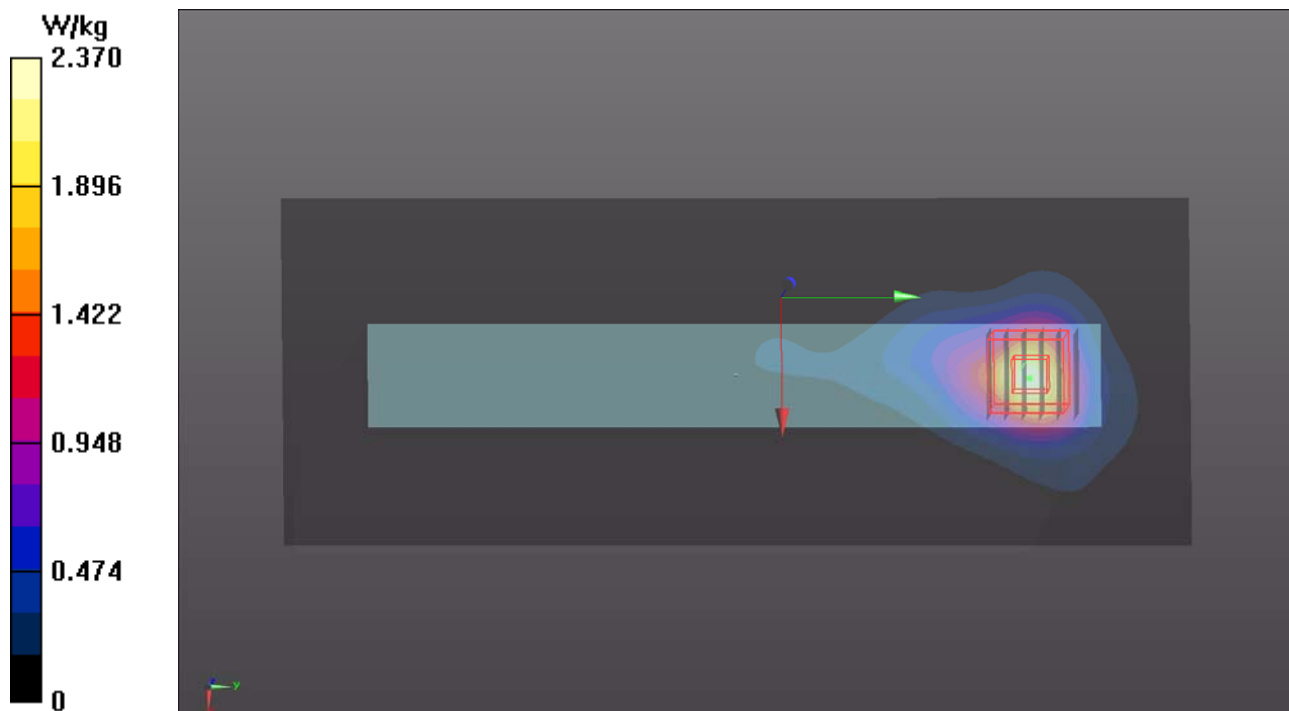

### P17 5.8G WLAN\_802.11n HT40\_Top Side\_0cm\_Ch159\_ANT 0+1

**DUT: 170926C17**

Communication System: WLAN\_5G; Frequency: 5795 MHz; Duty Cycle: 1:1

Medium: B34T60N1\_1028 Medium parameters used:  $f = 5795$  MHz;  $\sigma = 6.122$  S/m;  $\epsilon_r = 47.972$ ;  $\rho = 1000$  kg/m<sup>3</sup>

Ambient Temperature : 23.8 °C ; Liquid Temperature : 23.3 °C

DASY5 Configuration:

- Probe: EX3DV4 - SN7375; ConvF(4.08, 4.08, 4.08); Calibrated: 2016/12/08;
- Sensor-Surface: 1.4mm (Mechanical Surface Detection)
- Electronics: DAE3 Sn579; Calibrated: 2017/08/17
- Phantom: ELI Phantom\_1206; Type: QDOVA;
- Measurement SW: DASY52, Version 52.8 (8); SEMCAD X Version 14.6.10 (7373)

- **Area Scan (101x261x1):** Interpolated grid: dx=1.000 mm, dy=1.000 mm

Maximum value of SAR (interpolated) = 1.92 W/kg

- **Zoom Scan (6x6x12)/Cube 0:** Measurement grid: dx=5mm, dy=5mm, dz=2mm

Reference Value = 15.23 V/m; Power Drift = 0.07 dB

Peak SAR (extrapolated) = 5.18 W/kg

**SAR(1 g) = 1.28 W/kg; SAR(10 g) = 0.419 W/kg**

Maximum value of SAR (measured) = 2.96 W/kg

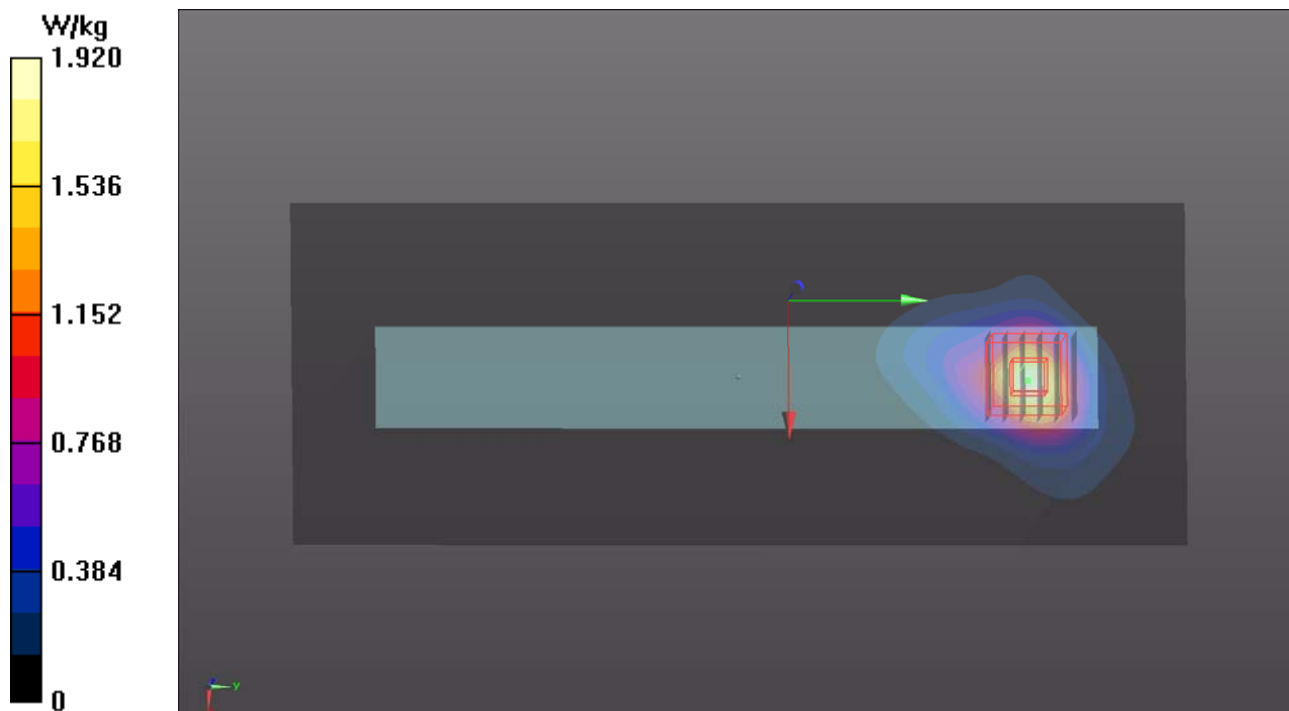

## P18 Bluetooth\_Rear Face\_0cm\_Ch39

**DUT: 170926C17**

Communication System: Bluetooth; Frequency: 2441 MHz; Duty Cycle: 1:1

Medium: B19T27N5\_1020 Medium parameters used:  $f = 2441$  MHz;  $\sigma = 1.957$  S/m;  $\epsilon_r = 51.458$ ;  $\rho = 1000$  kg/m<sup>3</sup>

Ambient Temperature : 23.5 °C ; Liquid Temperature : 23.3 °C

DASY5 Configuration:

- Probe: EX3DV4 - SN3971; ConvF(7.67, 7.67, 7.67); Calibrated: 2017/03/24;
- Sensor-Surface: 1.4mm (Mechanical Surface Detection)
- Electronics: DAE4 Sn1431; Calibrated: 2017/03/20
- Phantom: ELI Phantom\_1245; Type: QDOVA;
- Measurement SW: DASY52, Version 52.8 (8); SEMCAD X Version 14.6.10 (7373)

- **Area Scan (91x151x1):** Interpolated grid: dx=1.200 mm, dy=1.200 mm

Maximum value of SAR (interpolated) = 0.0193 W/kg

- **Zoom Scan (5x5x7)/Cube 0:** Measurement grid: dx=8mm, dy=8mm, dz=5mm

Reference Value = 2.929 V/m; Power Drift = -0.14 dB

Peak SAR (extrapolated) = 0.0320 W/kg

**SAR(1 g) = 0.016 W/kg; SAR(10 g) = 0.011 W/kg**

Maximum value of SAR (measured) = 0.0230 W/kg

