



**FCC Test Report**

FOR:

**Whistle Labs Inc.**

**Model Name:  
Whistle 3**

**Product Description:  
Pet GPS tracker and activity monitor**

**FCC ID: S8W-W03A  
IC ID: 10959A-W03A**

**47 CFR Part 15.247 (DTS)  
RSS-247 Issue 1 & RSS-Gen Issue 4**

**TEST REPORT #: EMC-WHIST-003-16001-15-247-DTS-WLAN**

**DATE: Dec. 14, 2016**



**FCC Recognized**

**A2LA Accredited**

***CETECOM Inc.***

411 Dixon Landing Road • Milpitas, CA 95035 • U.S.A.

Phone: +1 (408) 586 6200 • Fax: +1 (408) 586 6299 • E-mail: [info@cetecom.com](mailto:info@cetecom.com) • <http://www.cetecom.com>  
CETECOM Inc. is a Delaware Corporation with Corporation number: 2905571

**TABLE OF CONTENTS**

**1 Assessment ..... 4**

**2 Administrative Data..... 5**

2.1 Identification of the Testing Laboratory Issuing the Test Report..... 5

2.2 Identification of the Client ..... 5

2.3 Identification of the Manufacturer..... 5

**3 Equipment under Test (EUT) ..... 6**

3.1 Specification of the Equipment under Test ..... 6

3.2 EUT Sample details ..... 7

3.3 Accessory Equipment (AE) details..... 7

3.4 Ancillary Test Equipment (ATE) details ..... 7

3.5 EUT Sample Configuration ..... 7

3.6 Test modes of operation: ..... 8

**4 Subject Of Investigation ..... 9**

**5 Summary of Measurement Results..... 10**

**6 Measurement Uncertainty ..... 11**

6.1 Environmental Conditions During Testing:..... 11

6.2 Dates of Testing:..... 11

6.3 **Additional Test Information.**..... 11

**7 Measurement Procedures ..... 12**

7.1 Radiated Measurement ..... 12

7.2 Sample Calculations for Field Strength Measurements..... 14

7.3 Power Line Conducted Measurement Procedure ..... 14

7.4 RF Conducted Measurement Procedure ..... 15

7.4.1 *Conducted Measurement Setup without companion device.*..... 15

**8 Measurements and Results ..... 16**

8.1 Maximum Conducted (Average) Output Power and EIRP ..... 16

8.1.1 *Limits:* ..... 16

8.1.2 *Test Procedure* ..... 16

8.1.3 *Test Conditions:*..... 16

8.1.4 *Test Result: 2.4 GHz Band*..... 17

8.1.5 *Test Verdict:* ..... 17

8.1.6 *Test Data/plots: 2.4 GHz Band* ..... 18

8.2 Occupied Bandwidth (6 dB & 99%)..... 27

8.2.1 *Limits:* ..... 27

8.2.2 *Test Conditions:*..... 27

8.2.3 *Measurement procedure:*..... 27

8.2.4 *Test Result: 2.4 GHz Band*..... 27

8.2.5 *Measurement Result* ..... 27

8.2.6 *Test Data/plots: 2.4 GHz Band* ..... 28

8.3 Band Edge Compliance – at restricted and non-restricted band edges..... 37

8.3.1 *Limits:* ..... 37

8.3.2 *Test Conditions:*..... 37

8.3.3 *Measurement Procedure:*..... 38

8.3.4 *Measurement Result:* ..... 39

8.4	Test Data/plots: 2.4 GHz Band .....	40
8.4.1	Restricted Band Plots .....	43
8.5	Power Spectral Density .....	49
8.5.1	Selection of applicable test method.....	49
8.5.2	Limits: .....	49
8.5.3	Test Conditions:.....	49
8.5.4	Measurement procedure:.....	49
8.5.5	Test Data: 2.4 GHz Band.....	50
8.5.6	Measurement Result .....	50
8.5.7	Measurement Plots: 2.4 GHz Band.....	51
8.6	Radiated Transmitter Spurious Emissions: .....	60
8.6.1	Measurement according to ANSI C63.10 (2013) .....	60
8.6.2	Limits: .....	60
8.6.3	Test Conditions:.....	61
8.6.4	Measurement procedure:.....	61
8.6.5	Test Result: .....	61
8.6.6	Measurement Result .....	61
8.6.7	Test data/ plots: 2.4 GHz Band.....	62
8.7	<b>AC Power Line Conducted Emissions</b> .....	78
8.7.1	<b>Measurement according to ANSI C63.10 (2013)</b> .....	78
8.7.2	<b>Limits:</b> .....	78
8.7.3	<b>Test conditions and setup:</b> .....	78
8.7.4	<b>Measurement Result:</b> .....	78
8.7.5	<b>Measurement Plots:</b> .....	79
9	<b>EUT Setup Pictures</b> .....	81
10	<b>Test Equipment and Ancillaries used for tests</b> .....	81
11	<b>Revision History</b> .....	82

Date of Report : Dec. 14, 2016

---

**1 Assessment**

The following device was evaluated against the applicable criteria specified in FCC rules Parts 15.247 of Title 47 of the Code of Federal Regulations and

No deviations were ascertained during the course of testing performed.

Company	Description	Model #
Whistle Labs Inc.	Pet GPS tracker and activity monitor	Whistle 3

**Responsible for Testing Laboratory:**

		Franz Engert	
Dec 14, 2016	Compliance	(Compliance Manager)	
Date	Section	Name	Signature

**Responsible for the Report:**

		James Donnellan	
Dec 14, 2016	Compliance	(Sr. EMC Engineer)	
Date	Section	Name	Signature

The test results of this test report relate exclusively to the test item specified in Section 3. CETECOM Inc. USA does not assume responsibility for any conclusions and generalizations drawn from the test results with regard to other specimens or samples of the type of the equipment represented by the test item. The test report may only be reproduced or published in full. Reproduction or publication of extracts from the report requires the prior written approval of CETECOM Inc. USA.

Date of Report : Dec. 14, 2016

---

## 2 Administrative Data

### 2.1 Identification of the Testing Laboratory Issuing the Test Report

<b>Company Name:</b>	CETECOM Inc.
<b>Department:</b>	Compliance
<b>Address:</b>	411 Dixon Landing Road Milpitas, CA 95035 U.S.A.
<b>Telephone:</b>	+1 (408) 586 6200
<b>Fax:</b>	+1 (408) 586 6299
<b>Manager Compliance Services:</b>	Franz Engert
<b>Project Engineer:</b>	Ruther Navarro

### 2.2 Identification of the Client

<b>Applicant's Name:</b>	Whistle Labs INC
<b>Street Address:</b>	1355 Market St. #210.
<b>City/Zip Code</b>	San Francisco, CA, 94103
<b>Country</b>	USA
<b>Contact Name</b>	George Dang
<b>Phone No.</b>	1-973-960-0503
<b>e-mail:</b>	george@whistle.com

### 2.3 Identification of the Manufacturer

<b>Manufacturer's Name:</b>	Whistle Labs INC
<b>Manufacturers Address:</b>	1355 Market St. #210.
<b>City/Zip Code</b>	San Francisco, CA, 94103
<b>Country</b>	USA

Date of Report : Dec. 14, 2016

### 3 Equipment under Test (EUT)

#### 3.1 Specification of the Equipment under Test

<b>Model No:</b>	Whistle 3
<b>HW Version :</b>	EVT 2
<b>SW Version :</b>	0.0.1-C150591-S
<b>FCC-ID :</b>	S8W-W03A
<b>IC-ID:</b>	10959A-W03A
<b>HVIN:</b>	Pet GPS tracker and activity monitor.
<b>PMN:</b>	Whistle 3
<b>Product Description:</b>	A device to track pet location and monitor pet activities.
<b>Regulatory Band:</b>	Nominal band: 2400 – 2483.5 MHz
<b>Channels Used:</b>	2412 MHz (Ch. 1) – 2462 (Ch.11), 11 channels
<b>Type(s) of Modulation:</b>	802.11b/g/n with CCK, DQPSK, DBPSK + DSSS QBSK, BPSK, 16 QAM, 64 QAM + OFDM
<b>Modes of Operation:</b>	Communicates with Smartphone app.
<b>Antenna Type:</b>	FPC Antenna.
<b>Max. Declared Antenna Gain:</b>	Documented antenna gain: 2.4GHz = 1 dBi
<b>Max. Output power + Antenna Gain</b>	16 dBm EIRP (Max Power per Spec 15 db plus 1dbi gain)
<b>Power Supply:</b>	Lit-Ion Battery
<b>Rated Operating Voltage Range:</b>	Vmin: 3.0V / Vnom: 3.7V / Vmax: 4.4V DC
<b>Operating Temperature Range:</b>	Tlow: -20° - Tmax: 60° C
<b>Other Radios included in the Device:</b>	GPS BT LE Cellular
<b>Sample Revision:</b>	<input type="checkbox"/> Prototype; <input type="checkbox"/> Production; <input checked="" type="checkbox"/> Pre-Production

Date of Report : Dec. 14, 2016

## 3.2 EUT Sample details

EUT #	Serial Number	HW Version	SW Version	Notes/Comments
1	W03-000131	EVT 2	0.0.1-C150591-	Radiated Sample
2	W03-00010F	EVT 2	0.0.1-C150591-	Conducted Sample

## 3.3 Accessory Equipment (AE) details

AE #	Type	Model	Manufacturer	Serial Number	Notes
1	USB Charging Dock	N/A	Whistle Labs Inc.	N/A	Used to Charge Device.
2	-	-	-	-	-

## 3.4 Ancillary Test Equipment (ATE) details

ATE #	Type	Model	Manufacturer	SN / PN	Notes
1	Laptop	Latitude	DELL	BW21LQ	Used to Set channel.
2	AC Charger	PE98ED	Amazon	PA-1050-07AZ	5W USB Charger

## 3.5 EUT Sample Configuration

EUT Set-Up #	Combination of AE used for test set up	Comments
1	EUT1 + AE1+ ATE2	The radio of the EUT was stimulated directly in a test mode not accessible by the end user via a USB connection with the ATE1 laptop utilizing a GUI. After which The ATE1 was removed and the EUT transmitted a modulated WiFi signal on a specified channel. To maintain battery power the AE1 and ATE2 was used as needed. The internal antenna was connected.
2	EUT2 +ATE1	The radio of the EUT was stimulated directly in a test mode not accessible by the end user via a USB connection with the ATE1 laptop utilizing a GUI. The EUT transmitted a modulated WiFi signal on a specified channel. The radio transmission was verified with a spectrum analyzer during the course of testing. The measurement equipment was connected to the 50Ohm UFL port of the EUT.

Date of Report : Dec. 14, 2016

---

### 3.6 Test modes of operation:

The below listed worst case test modes of operation have been established from the output power measurement and evaluation of long term test data available to the lab for the different data rates and modulations which are supported by the equipment.

Modes of Operation		Data rate (Mbps)	Modulation Scheme
2.4 GHz	802.11b	1.0	DSSS
	802.11g	6.0	BPSK
	802.11n (20 MHz)	6.5	BPSK

The device was configured with a manufacturer provided test SW, capable of setting the unit in different supported modulation schemes with data rates specified and user selected channels of operation.

The Device was set to continuous framed Tx (burst) mode per test SW and could thus be operated with > 98% duty cycle during testing of 80211b.

The EUT was tested on low, mid and high channels (2.4GHz) in 802.11b, 802.11g, and 802.11n (HT20) modes (n-mode is used with 20 MHz channel bandwidth (HT20) only).



#### 4 Subject Of Investigation

The objective of the measurements applied by Cetecom Inc. was to establish compliance of the EUT as described under Ch. 3 of this Test Report, with the applicable criteria specified in FCC rules Part 15.247 of Title 47 of the Code of Federal Regulations.

This test report is to support a request for new equipment authorization under the FCC ID: S8W-W03A and IC ID: 10959-W03A

All testing was performed on the product referred to in Section 3 as EUT.

Testing procedures are based on ANSI C63.10:2013 for DTS devices and FCC KDB 558074 D01 v03r05, "GUIDANCE FOR PERFORMING COMPLIANCE MEASUREMENTS ON DIGITAL TRANSMISSION SYSTEMS (DTS) OPERATING UNDER §15.247" and

## 5 Summary of Measurement Results

Test Specification	Test Case	Temperature and Voltage Conditions	Mode	Pass	Fail	NA	NP	Result
§15.247(e) RSS-247 5.2(1)	Power Spectral Density	Nominal	802.11b 802.11g 802.11n	■	□	□	□	Complies
§15.247(a)(1) RSS-247 5.2(2)	Emission Bandwidth	Nominal	802.11b 802.11g 802.11n	■	□	□	□	Complies
§15.247(b)(3) RSS-247 5.4(4)	Maximum Peak Conducted Output Power	Nominal	802.11b 802.11g 802.11n	■	□	□	□	Complies
§15.247(d) RSS-Gen 8.9/8.10 RSS-247 5.5	Band edge compliance	Nominal	802.11b 802.11g 802.11n	■	□	□	□	Complies
§15.247(d) RSS-Gen 6.13	TX Spurious emissions-Conducted	Nominal	802.11b 802.11g 802.11n	□	□	□	■	See Note 1
§15.247(d) §15.209(a) RSS-Gen 6.13	TX Spurious emissions-Radiated	Nominal	802.11b 802.11n	■	□	□	□	Complies
§15.207(a) RSS Gen 8.8	AC Conducted Emissions <30MHz	Nominal	802.11b 802.11g 802.11n	■	□	□	□	Complies

NA= Not Applicable; NP= Not Performed.

Note 1: Conducted spurious emissions test against non-restricted band limits is NOT PERFORMED since radiated spurious emissions against more stringent restricted band limits over the complete measurement range (9kHz to 26GHz) has passed.

## 6 Measurement Uncertainty

Where relevant, the following measurement uncertainty levels have been estimated for tests performed on the apparatus, with 95% confidence interval (in dB delta to result), based on a coverage factor k=1.

	Uncertainty in dB radiated <30MHz	Uncertainty in dB radiated 30MHz - 1GHz	Uncertainty in dB radiated > 1GHz
<b>standard deviation k=1</b>	2.48	1.94	2.16
<b>95% confidence interval in dB</b>	4.86	3.79	4.24
<b>95% confidence interval in dB in delta to Result (rounded up to next decimal point)</b>	+/- 2.5 dB	+/- 2.0 dB	+/- 2.3dB

Conducted measurement:

150 kHz to 30 MHz  $\pm 0.7$  dB (LISN)

RF conducted measurement  $\pm 0.5$  dB

According to TR 102 273 a multiplicative propagation of error is assumed for RF measurement systems. For this reason the RMS method is applied to dB values and not to linear values as appropriate for additive propagation of error. Also used: <http://physics.nist.gov/cuu/Uncertainty/typeb.html>. The above calculated uncertainties apply to direct application of the Substitution method. The Substitution method is always used when the EUT comes closer than 3dB to the limit.

### 6.1 Environmental Conditions During Testing:

The following environmental conditions were maintained during the course of testing:

- Ambient Temperature: 20-25°C
- Relative humidity: 40-60%

### 6.2 Dates of Testing:

2016-09-15 to 2016-10-21

### 6.3 Additional Test Information.

Testing is performed according to the guidelines provided in FCC publication (KDB) FCC KDB 558074 D01 V03R05, *GUIDANCE FOR PERFORMING COMPLIANCE MEASUREMENTS ON DIGITAL TRANSMISSION SYSTEMS (DTS) OPERATING UNDER §15.247* and according to relevant parts of ANSI 63.10 (2013) as detailed below.

## 7 Measurement Procedures

### 7.1 Radiated Measurement

The radiated measurement is performed according to:  
ANSI C63.10 (2013)

- The exploratory measurement is accomplished by running sweeps at 1 and 4m antenna heights over the required frequency range with R&S Test-SW EMC32 for both antenna polarizations. During each frequency scan the turntable rotates by no more than 10deg.
- The 10 highest emissions are selected with an automatic algorithm of EMC32 searching for peaks in the noise floor and ensuring that broadband signals are not selected multiple times.
- The maxima are then again maximized through a fine search in frequency domain, maximized in the 360deg range of the turntable, and maximized over antenna height between 1m and 4m and for positioning of the EUT.
- The above procedure is repeated for transmission low mid and high channel.
- In case there are no emissions above noise floor level only the maximum trace is reported as described above.
- The results are split up into up to 4 frequency ranges due to antenna bandwidth restrictions. A magnetic loop is used from 9 kHz to 30 MHz, a Biconilog antenna is used from 30 MHz to 1 GHz, and two different horn antennas are used to cover frequencies up to 40 GHz.

#### Radiated Emissions Test Setup Below 30MHz Measurements

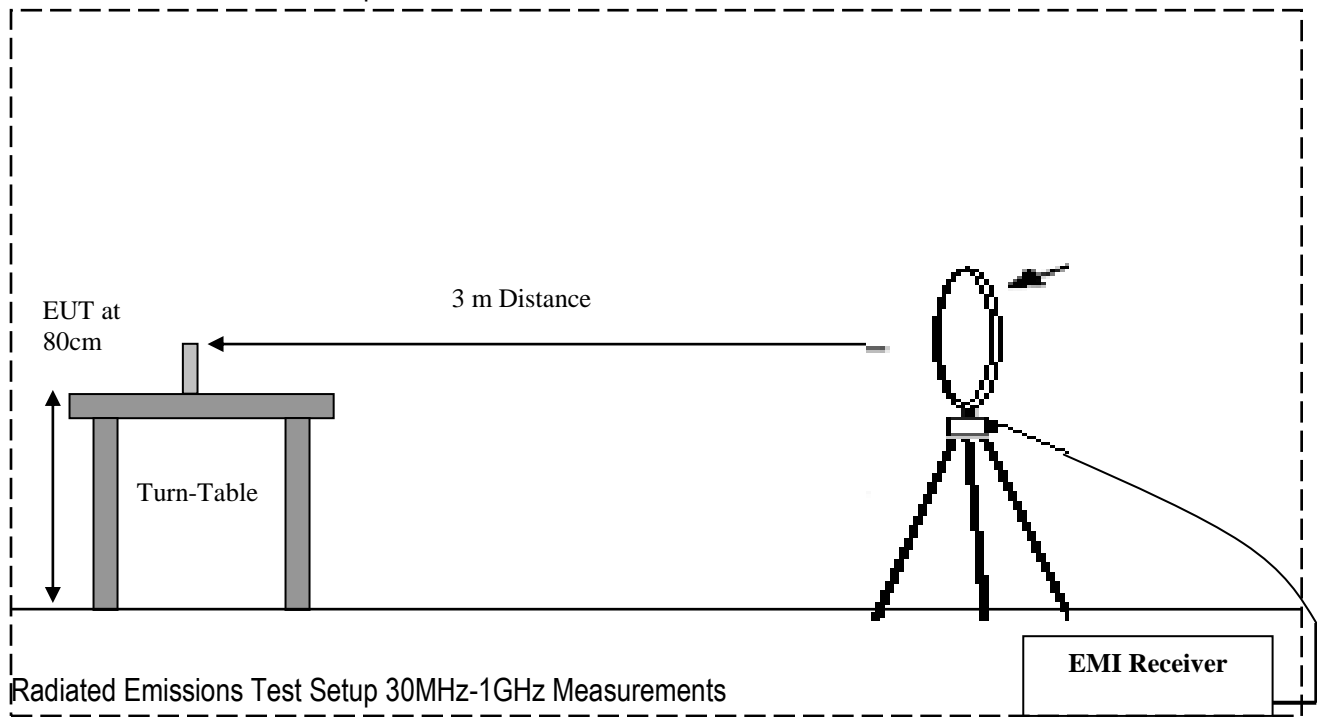

Date of Report : Dec. 14, 2016

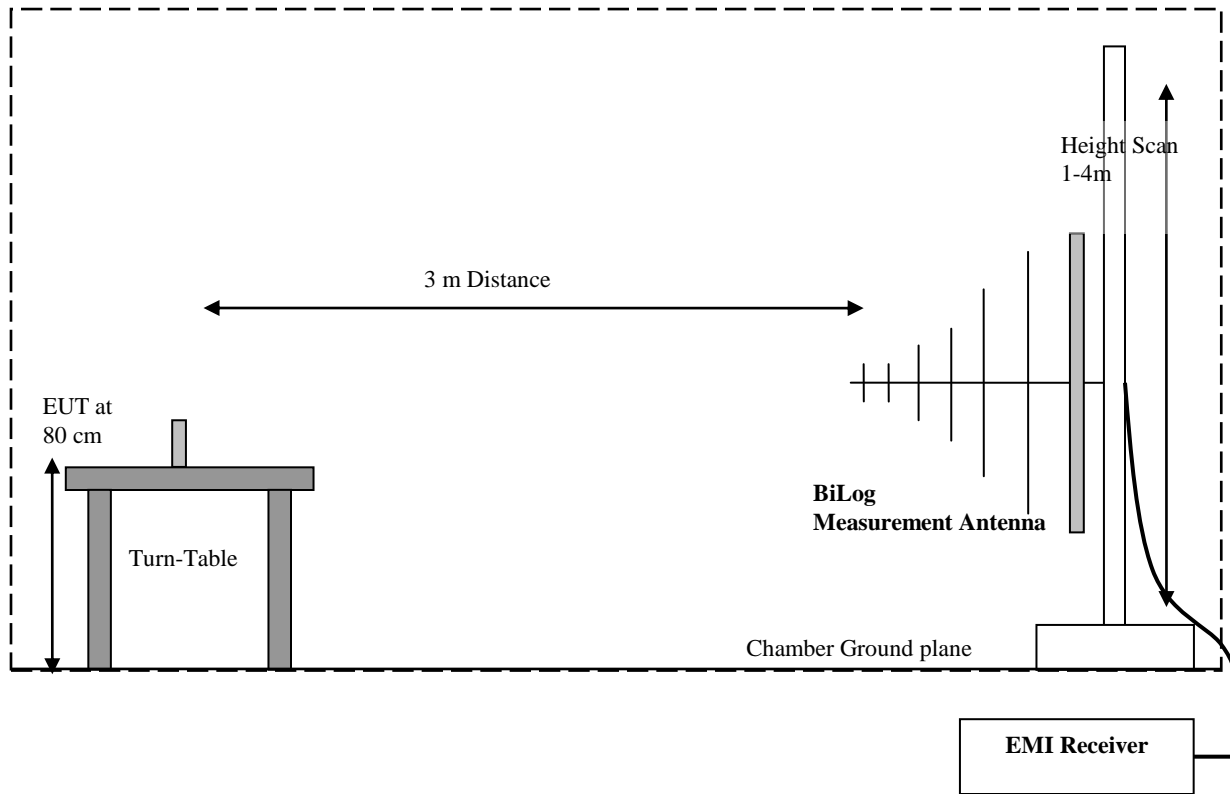

### Radiated Emissions Test Setup Above 1GHz Measurements

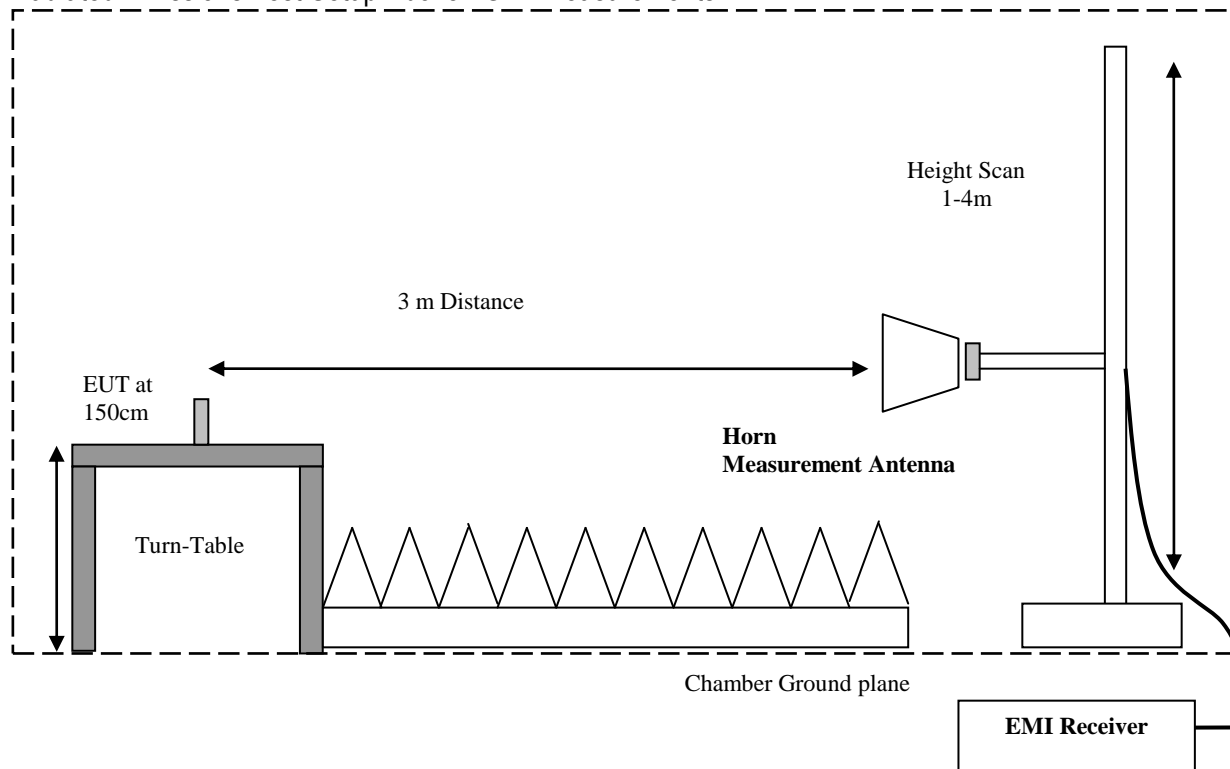

### 7.2 Sample Calculations for Field Strength Measurements

Field Strength is calculated from the Spectrum Analyzer/ Receiver readings, taking into account the following parameters:

1. Measured reading in dBμV
2. Cable Loss between the receiving antenna and SA in dB and
3. Antenna Factor in dB/m

All radiated measurement plots in this report are taken from a test SW that calculates the Field Strength based on the following equation:

$$FS \text{ (dB}\mu\text{V/m)} = \text{Measured Value on SA (dB}\mu\text{V)} - \text{Cable Loss (dB)} + \text{Antenna Factor (dB/m)}$$

Example:

Frequency (MHz)	Measured SA (dBμV)	Cable Loss (dB)	Antenna Factor Correction (dB)	Field Strength Result (dBμV/m)
1000	80.5	3.5	14	98.0

### 7.3 Power Line Conducted Measurement Procedure

AC Power Line conducted emissions measurements performed according to: ANSI C63.4 (2014)

## 7.4 RF Conducted Measurement Procedure

### 7.4.1 Conducted Measurement Setup without companion device

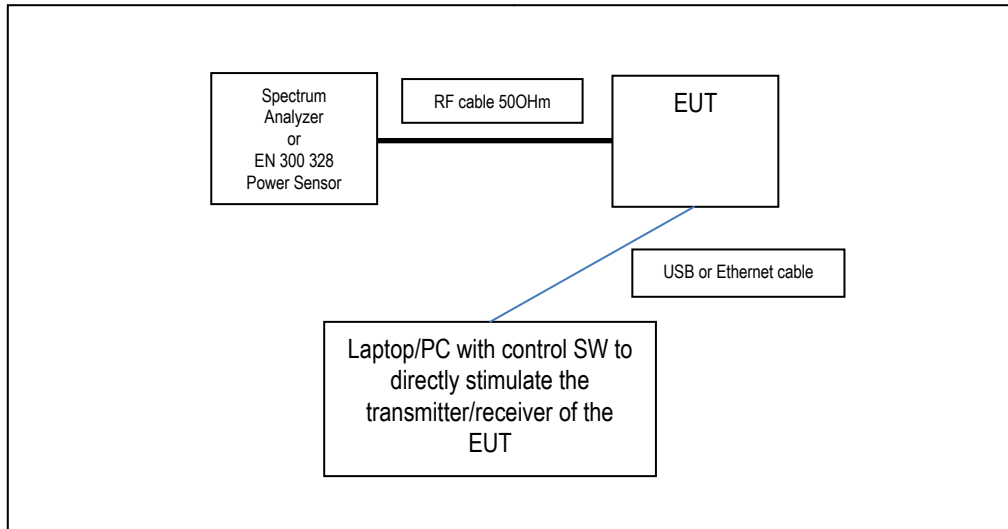

## 8 Measurements and Results

### 8.1 Maximum Conducted (Average) Output Power and EIRP

#### 8.1.1 Limits:

##### Maximum Peak Output Power:

FCC §15.247 (b)(3): 1W

#### 8.1.2 Test Procedure

Duty cycle measurement according to FCC KDB 558074 D01 v03r05 section 6.0.

Power measurement according to FCC KDB 558074 D01 DTS v03r05 section 9.2.2.4 §15.247 permits the maximum (average) conducted output power to be measured. Using Method AVGSA-2 (Trace Averaging across on and off times of the EUT transmission followed by duty cycle correction.)

##### Spectrum Analyzer settings:

##### Maximum Average Output Power

Span ≥ 1.5 times the OBW.

RBW = 1-5 % of the OBW not to exceed 1 MHz

VBW ≥ 3xRBW

Sweep = auto

Detector function = RMS

Trace = Average of 100 traces

Use integrated band power method. Set channel bandwidth ≥ OBW bandwidth of the emission being measured.

OBW values are given in section 7.2

#### 8.1.3 Test Conditions:

Ambient Temperature	EUT Set-Up #	EUT operating mode	Power Input
22.4° C	2	Tx	Laptop



Date of Report : Dec. 14, 2016

8.1.4 Test Result: 2.4 GHz Band

Measured Average Conducted Output Power (dBm)			
	2412 MHz Channel 1	2437 MHz Channel 6	2462 MHz Channel 11
802.11b	12.12	12.61	12.84
802.11g	12.12	12.4	12.15
802.11n /MCS0 (20 MHz)	11.6	11.93	11.29

In addition the Duty cycle for the corresponding modes was as follows based on measurements of the mid channel.

Duty Cycle Measured		
802.11b Channel 6	802.11g Channel 6	802.11n Channel 6
99	97	97

Accounting for Duty Cycle Adjustment for g and n mode

Duty Cycle Adjusted Average Conducted Output Power (dBm)			
Mode	Frequency (MHz)		
	2412 Channel 1	2437 Channel 6	2462 Channel 11
802.11b	12.12	12.61	12.84
802.11g	12.25	12.53	12.28
802.11n /MCS0 (20 MHz)	11.73	12.06	11.42

Add Antenna Gain 1 dBi to get EIRP			
Mode	Frequency (MHz)		
	2412 Channel 1	2437 Channel 6	2462 Channel 11
802.11b	13.12	13.61	13.84
802.11g	13.25	13.53	13.28
802.11n /MCS0 (20 MHz)	12.73	13.06	12.42

8.1.5 Test Verdict:  
Passed

Date of Report : Dec. 14, 2016

8.1.6 Test Data/plots: 2.4 GHz Band  
See plots below.

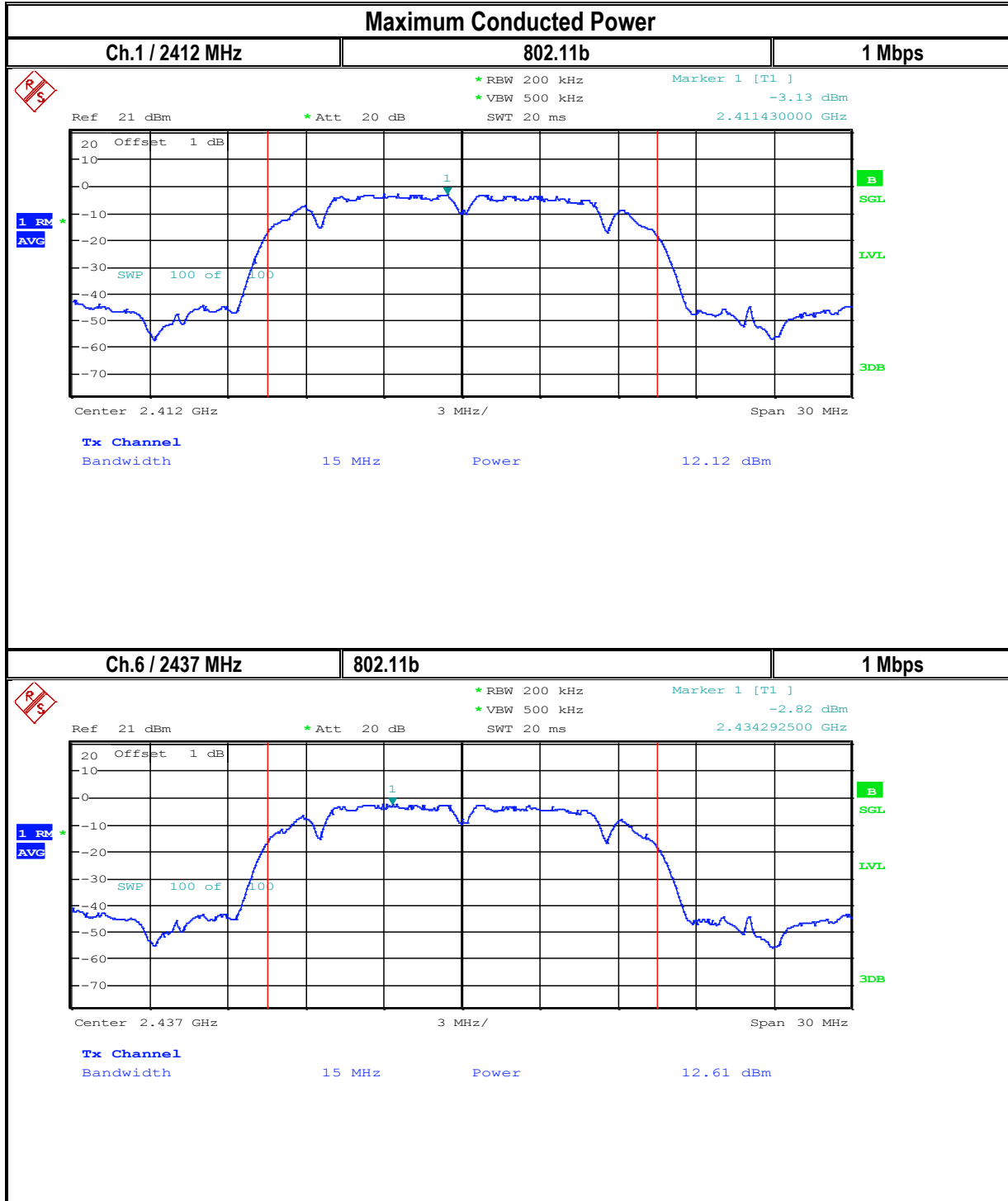

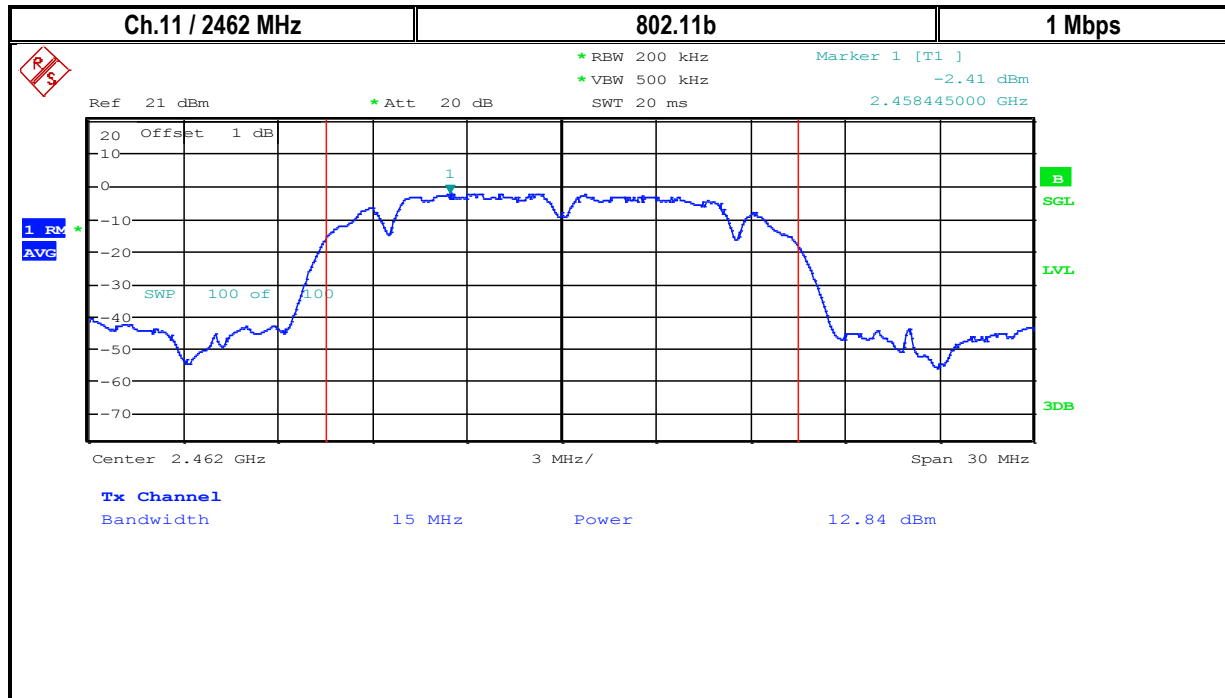

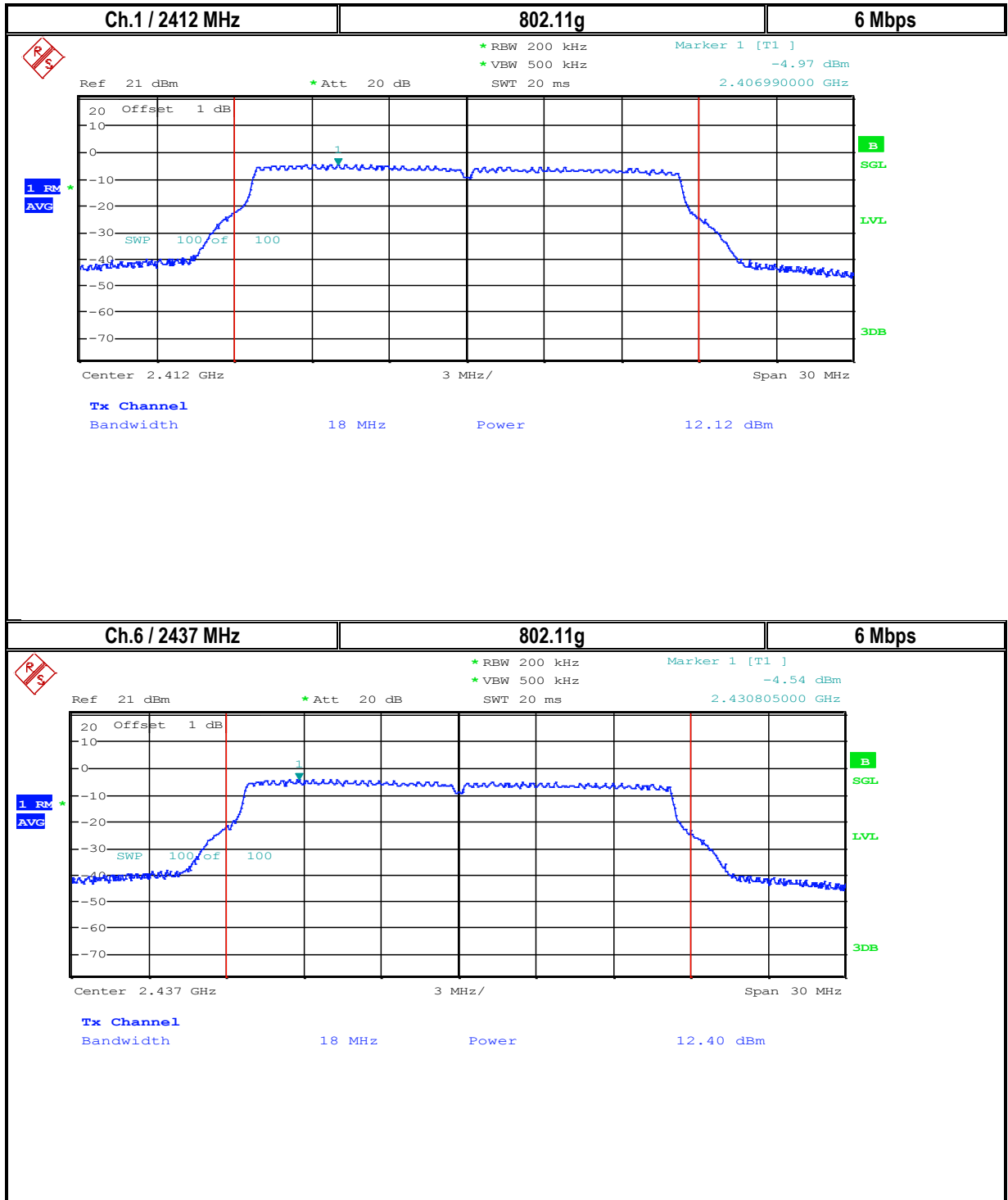

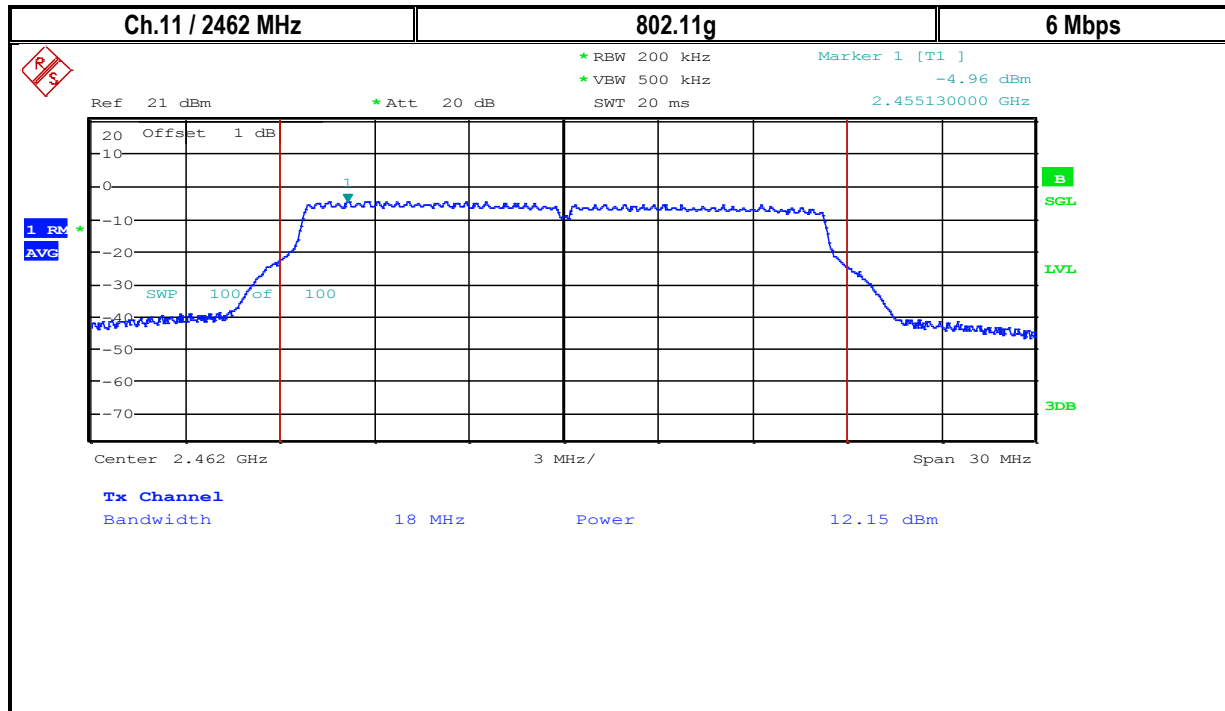

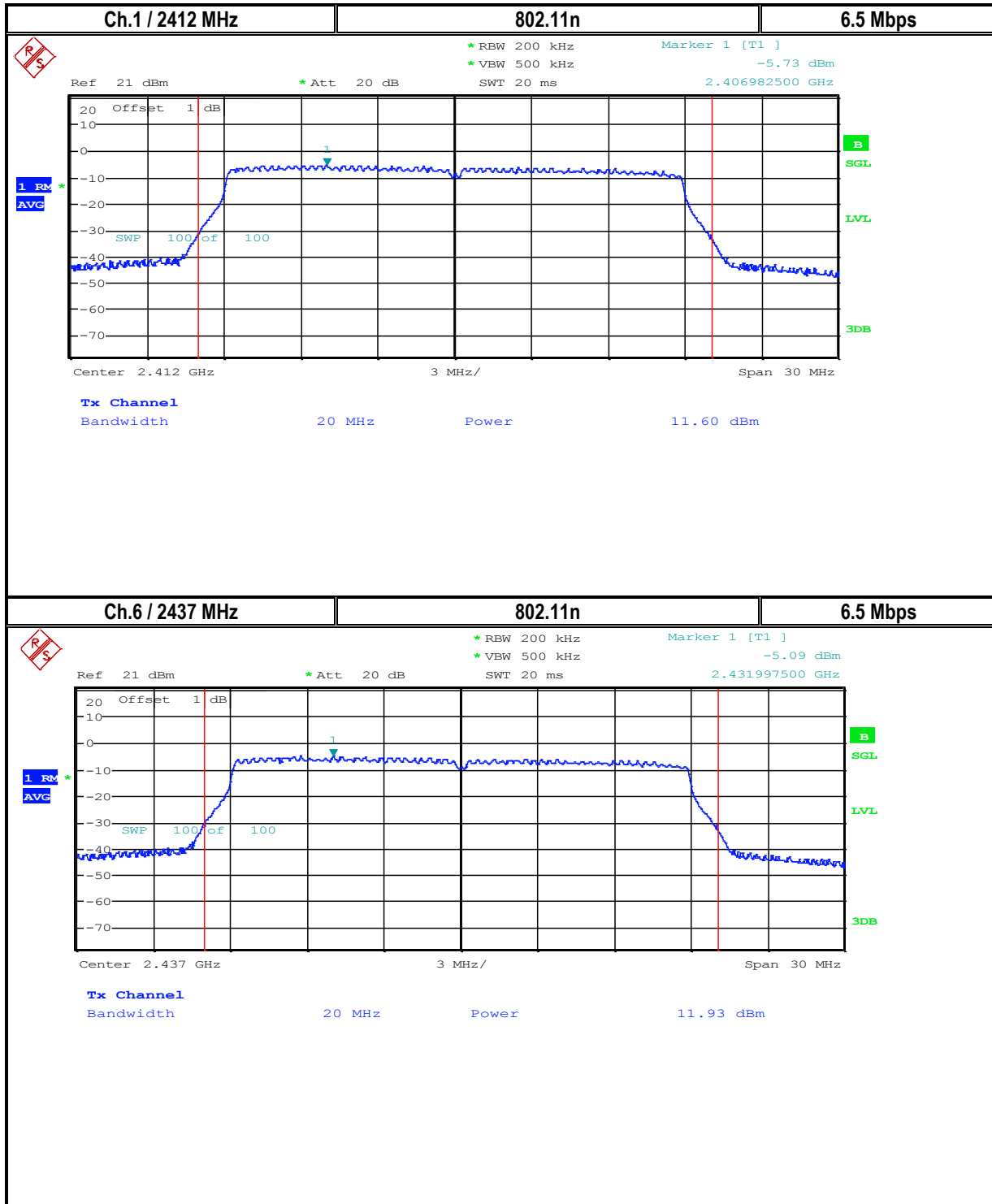

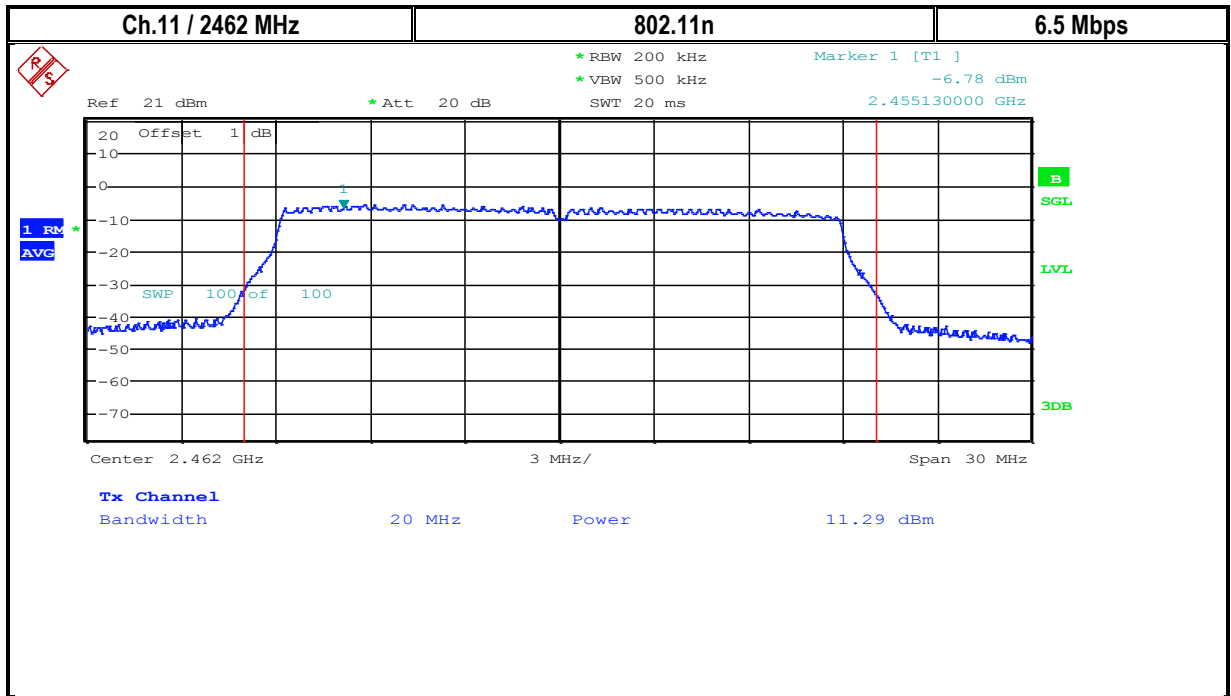

Date of Report : Dec. 14, 2016

Duty Cycle Plots

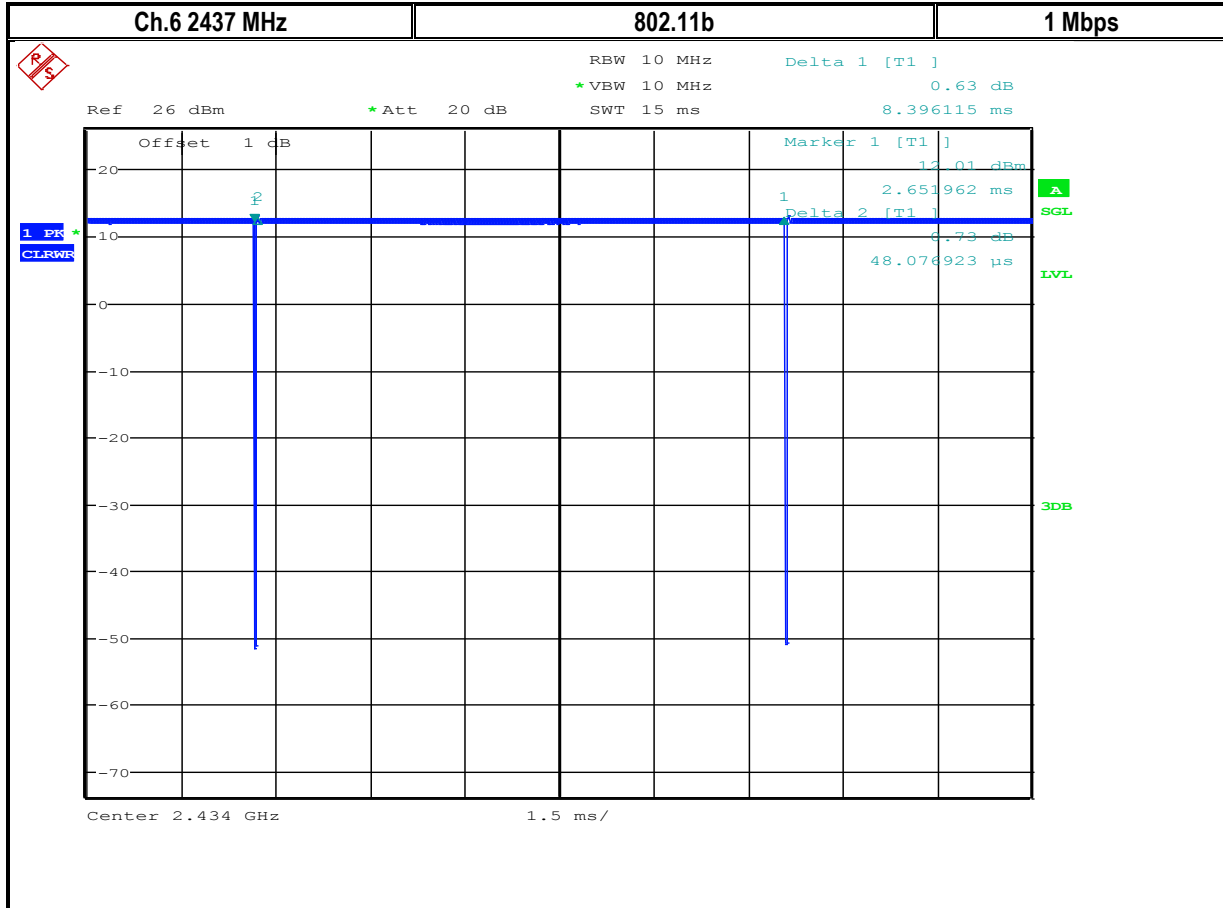



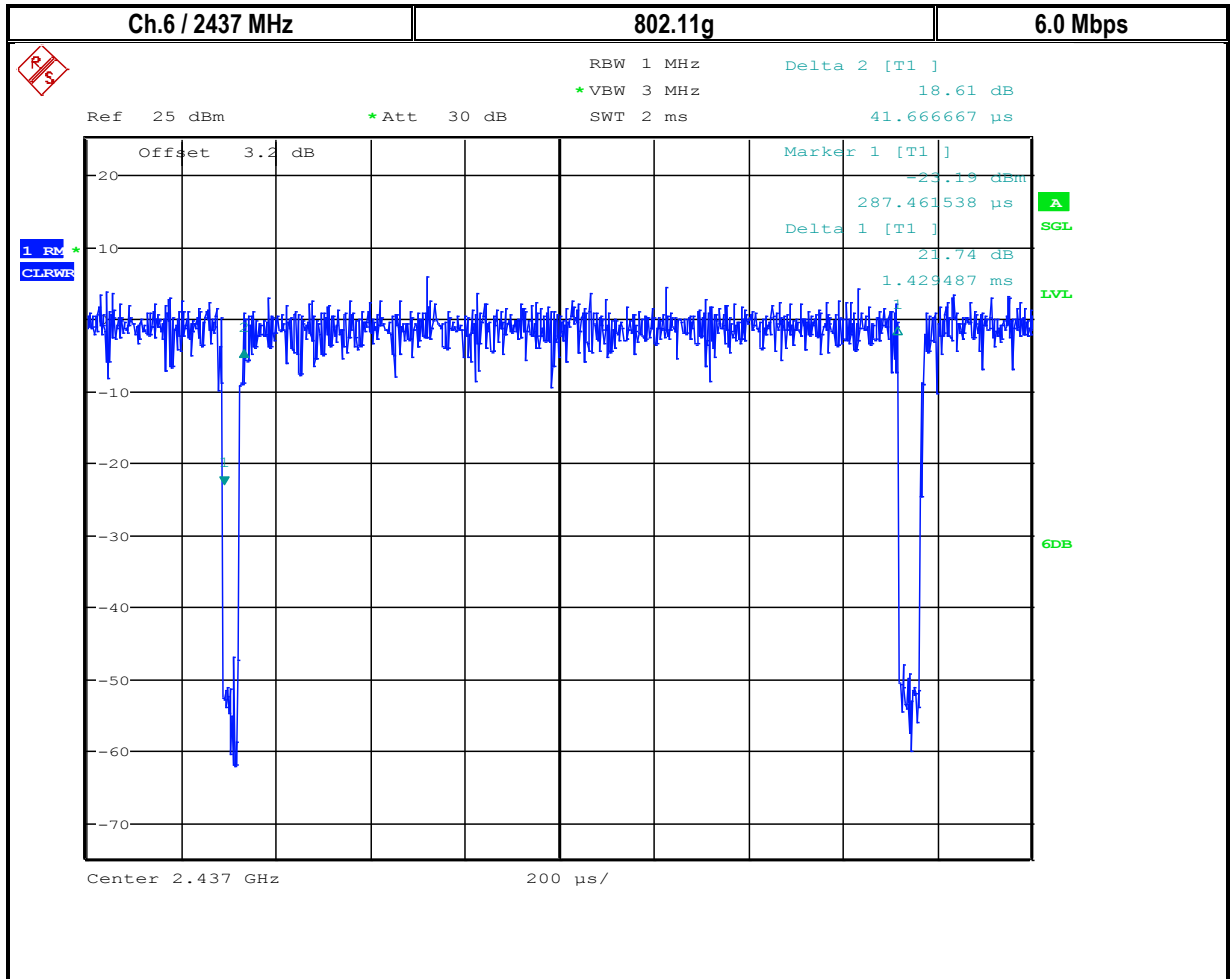

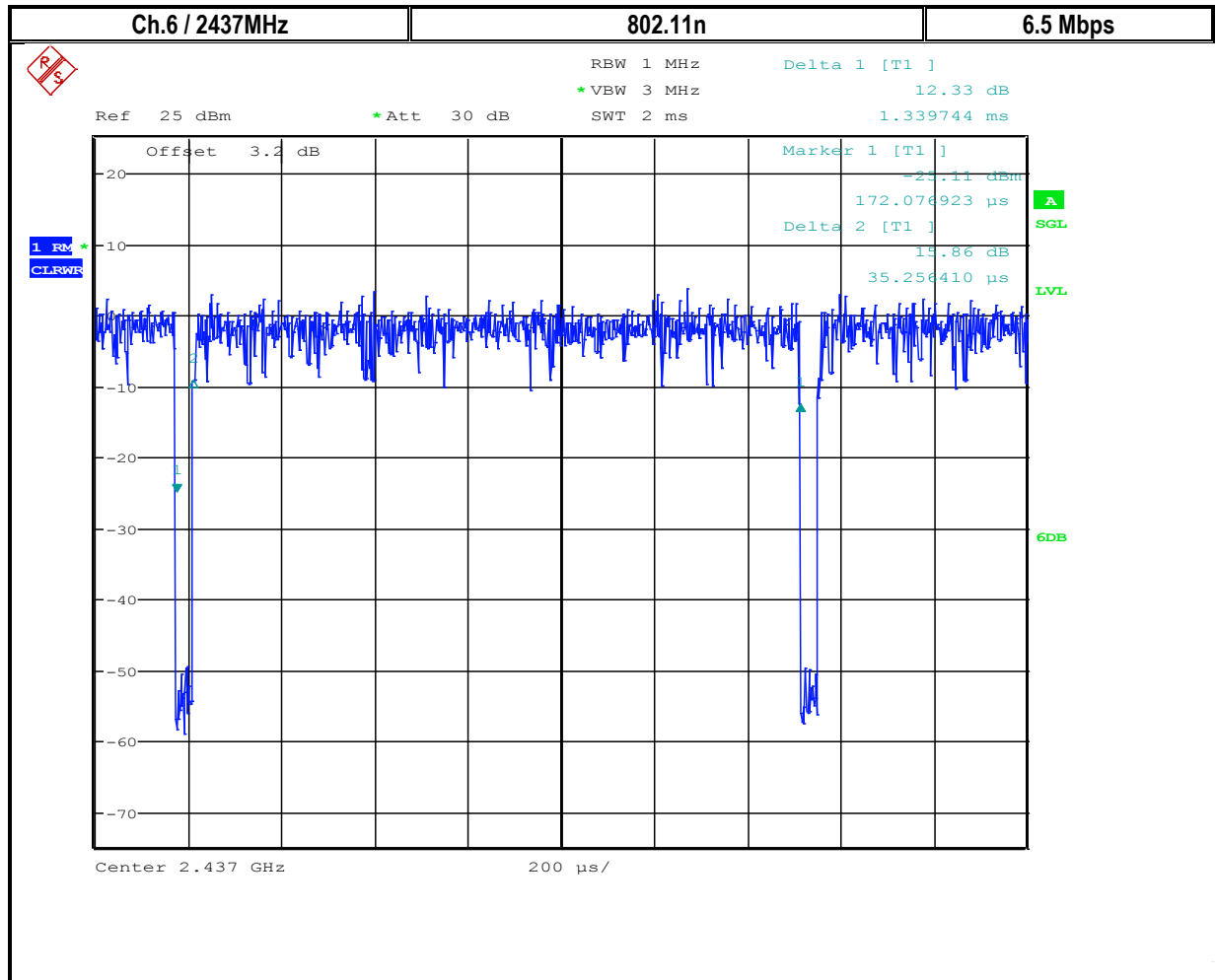

1) T refers to the minimum transmission duration over which the transmitter is ON and is transmitting at its maximum power control level for the tested mode of operation

Mode	T = Min duration Tx is On.
80211.b	8.34 ms
80211.g	1.38 ms
80211.n	1.30 ms

Date of Report : Dec. 14, 2016

---

8.2 Occupied Bandwidth (6 dB & 99%)

8.2.1 Limits:

§15.247 (a)(2)

Systems using digital modulation techniques may operate in the 902–928 MHz, 2400–2483.5 MHz, and 5725–5850 MHz bands. The minimum 6 dB bandwidth shall be at least 500 kHz.

8.2.2 Test Conditions:

Ambient Temperature	EUT Set-Up #	EUT operating mode	Power Input
21.6° C	2	Tx	Laptop

8.2.3 Measurement procedure:

For 6dB according to C63-10-2013 section 6.9.2 Occupied bandwidth Relative Measurement procedure.  
 For 99% according to C63-10-2013 section 6.9.3 power bandwidth (99%) measurement procedure in conjunction with the 99% power bandwidth function of the Spectrum Analyzer.

**Spectrum Analyzer settings:**

Span = 2 to 5 x the occupied BW

RBW = 1% to 5 % of the occupied BW, unless otherwise specified

VBW ≥ 3xRBW, Detector: Peak- Max hold;

Sweep Time: Auto

Allow the trace to stabilize

8.2.4 Test Result: 2.4 GHz Band

Occupied Bandwidth (MHz)						
Mode	Frequency (MHz)					
	2412 Channel 1		2437 Channel 6		2462 Channel 11	
	6dB	99%	6dB	99%	6dB	99%
802.11b	11.01	13.95	10.98	13.98	10.98	13.95
802.11g	16.50	17.64	16.55	17.55	16.47	17.67
802.11n (20MHz)	17.70	18.39	17.82	18.36	17.76	18.39

8.2.5 Measurement Result

Pass.

Date of Report : Dec. 14, 2016

8.2.6 Test Data/plots: 2.4 GHz Band

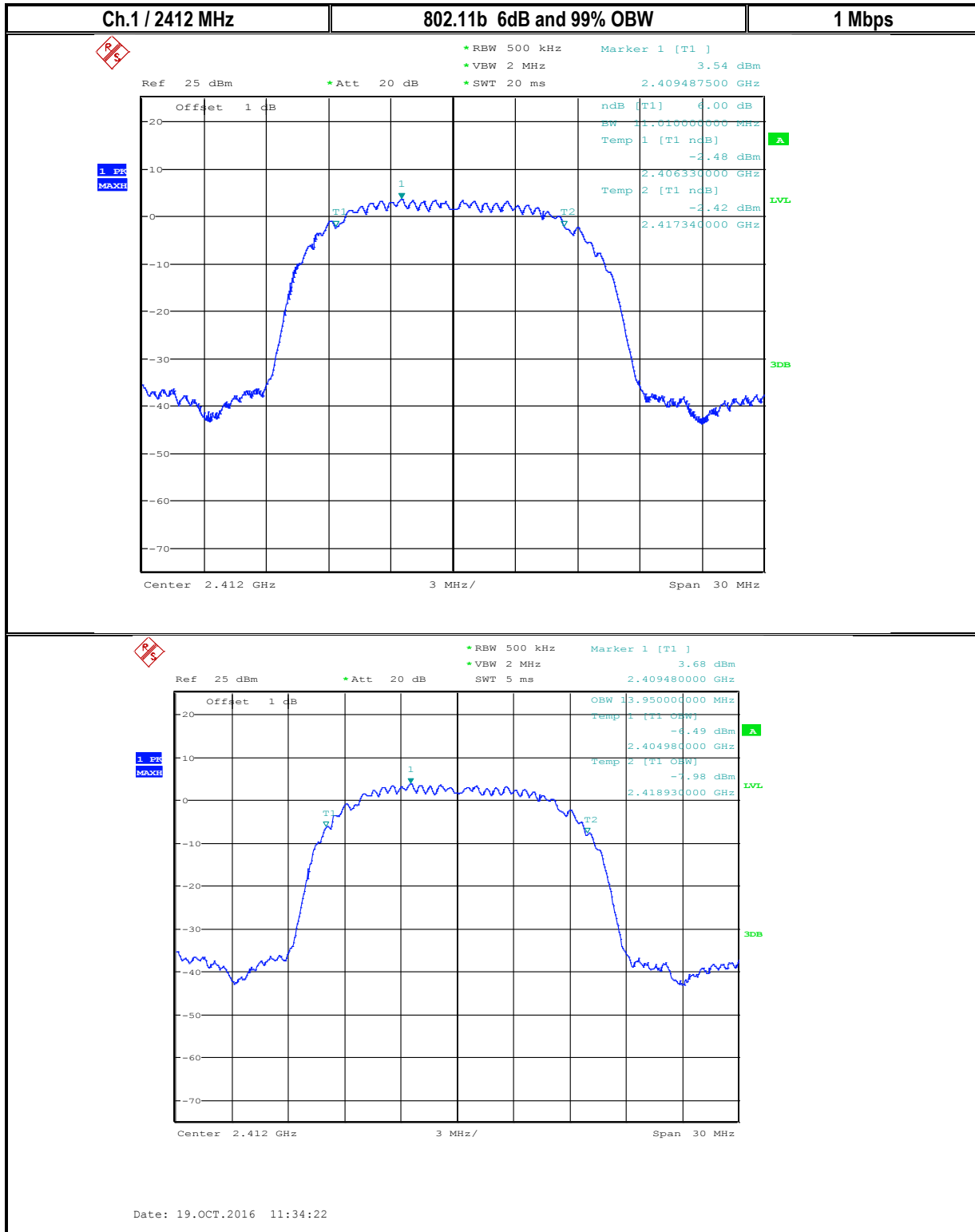

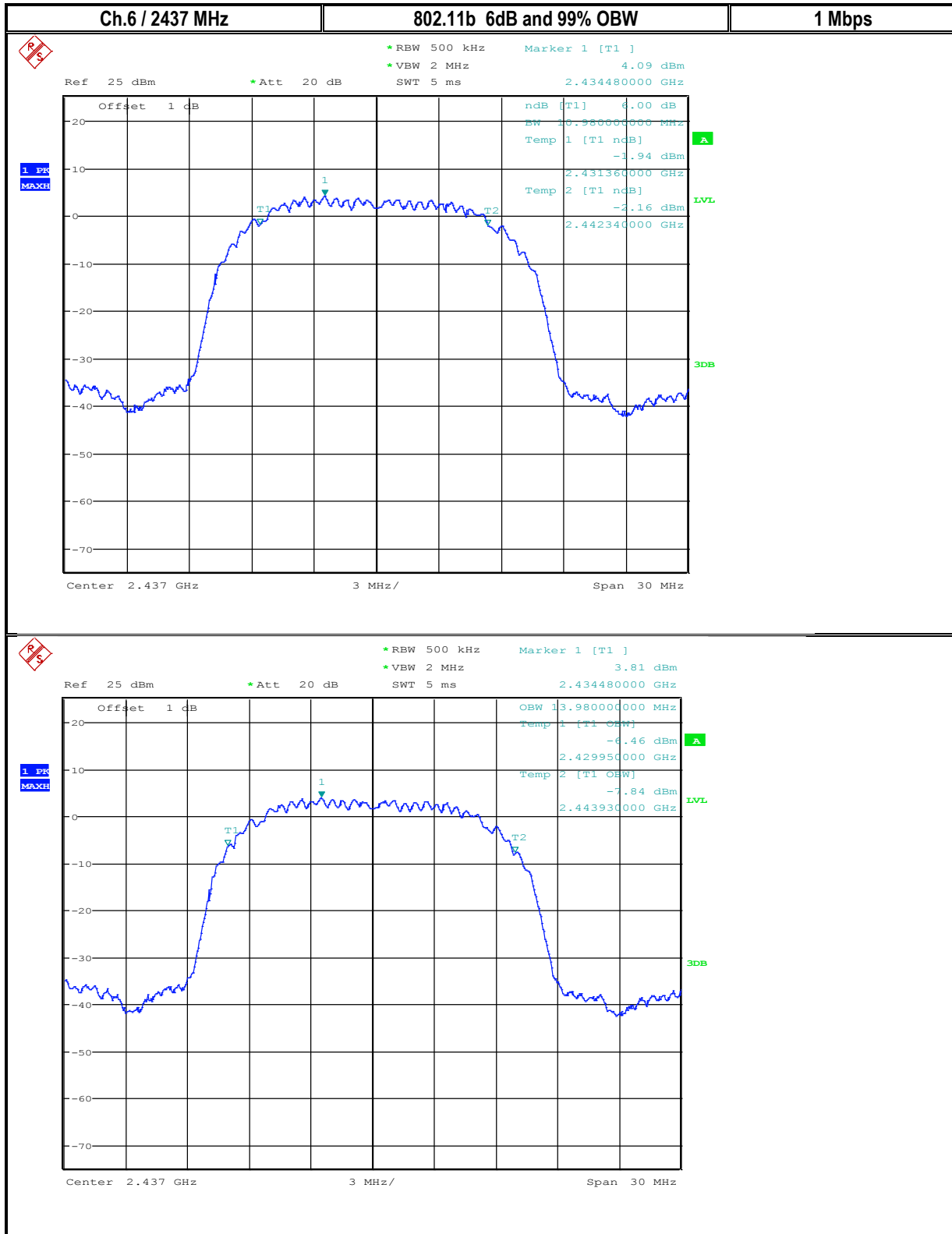

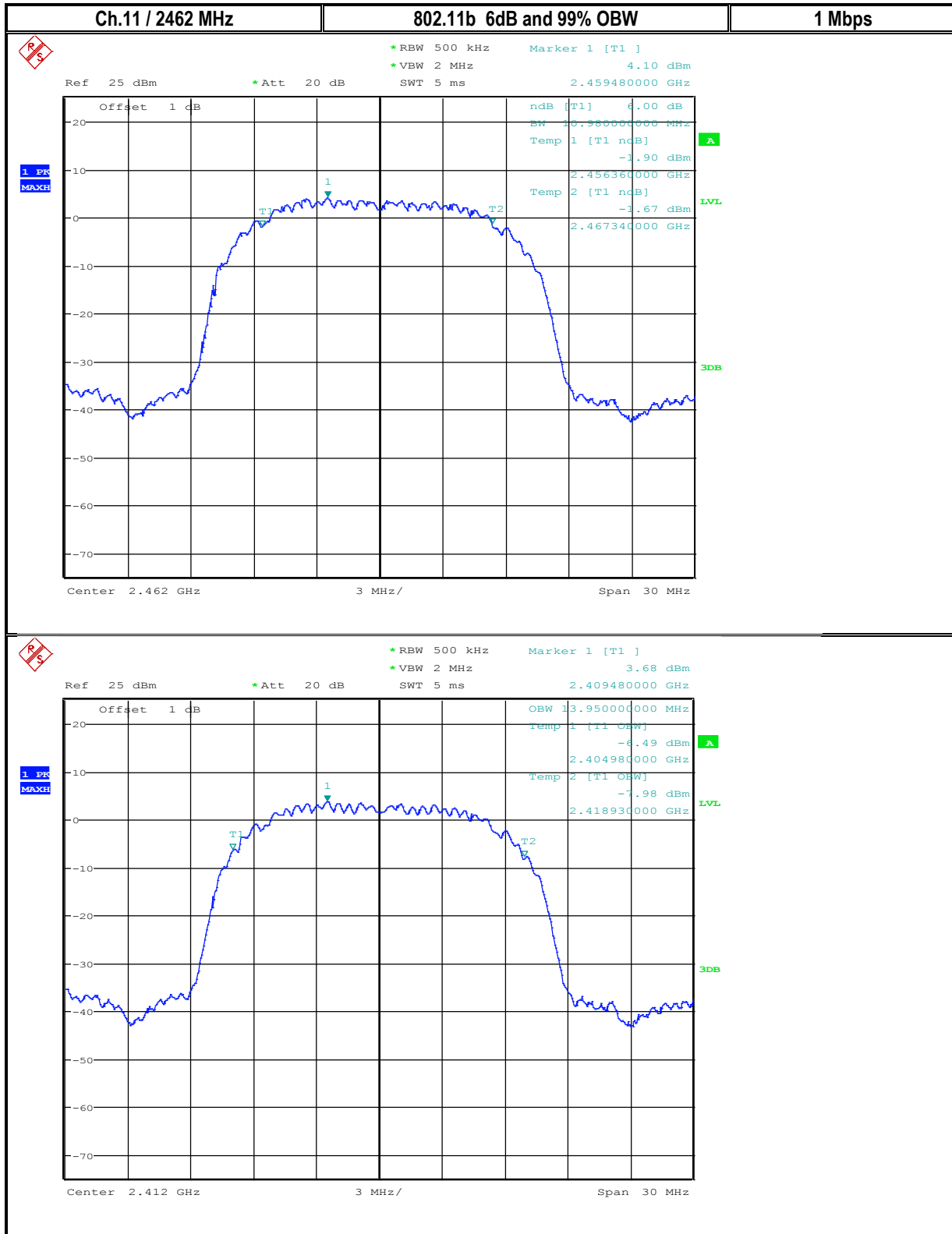

Date of Report : Dec. 14, 2016

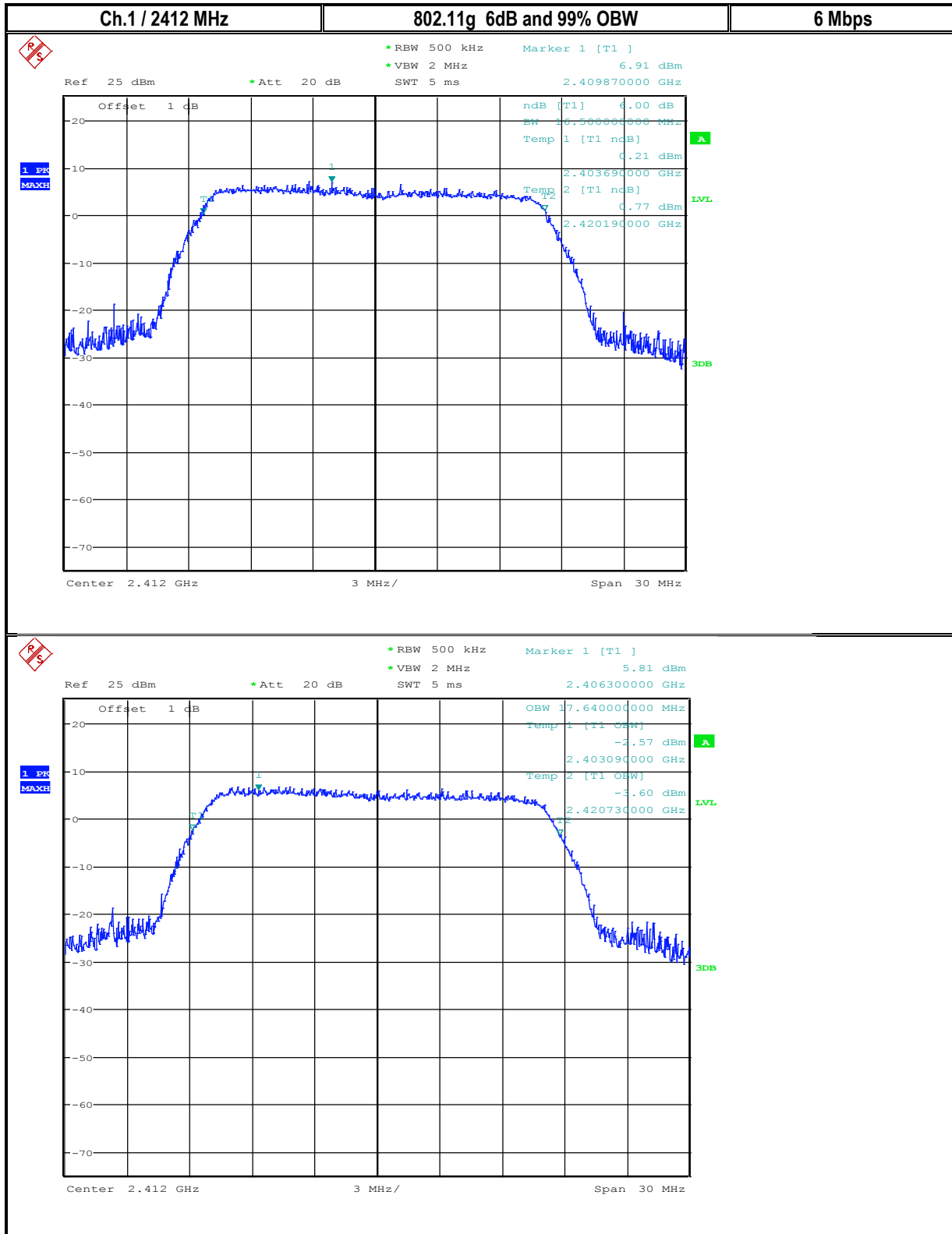

Date of Report : Dec. 14, 2016

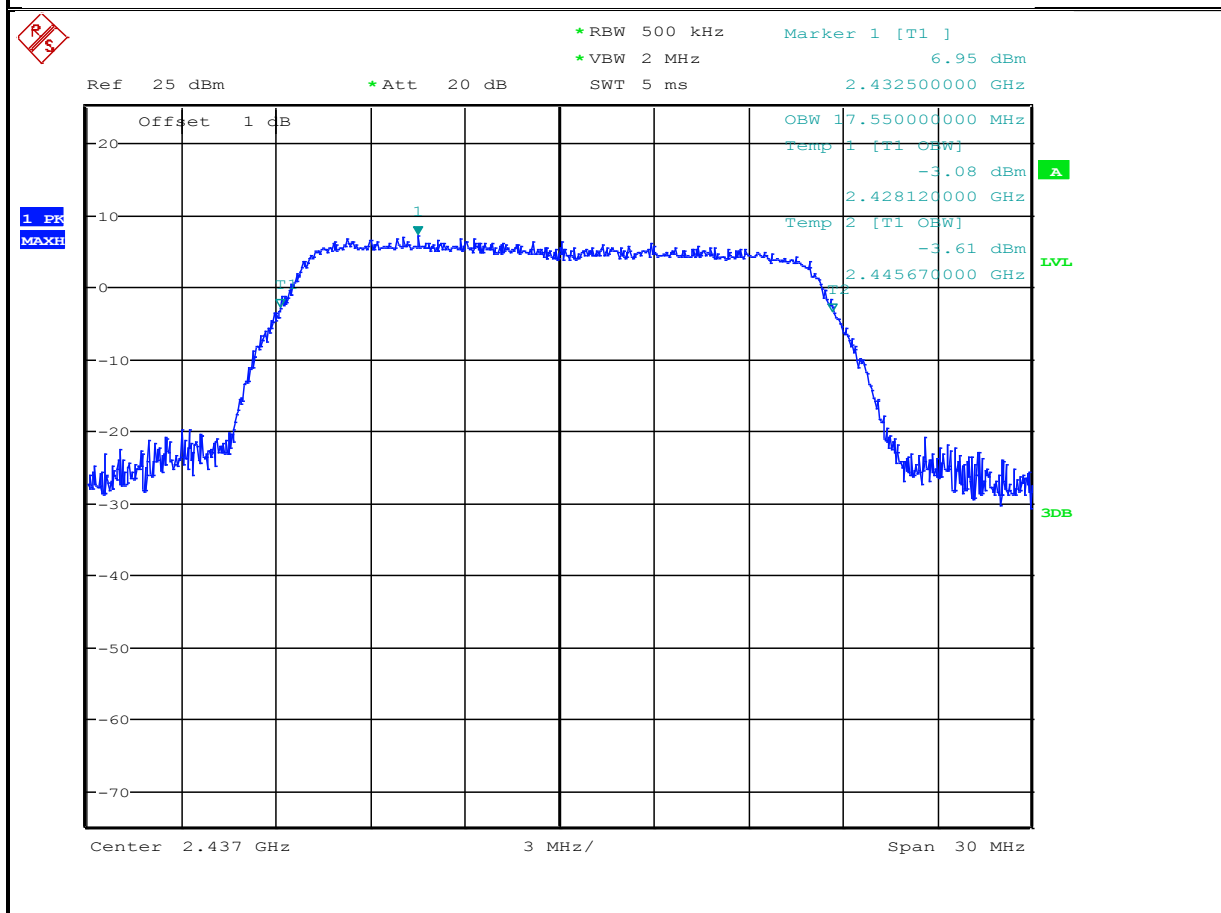
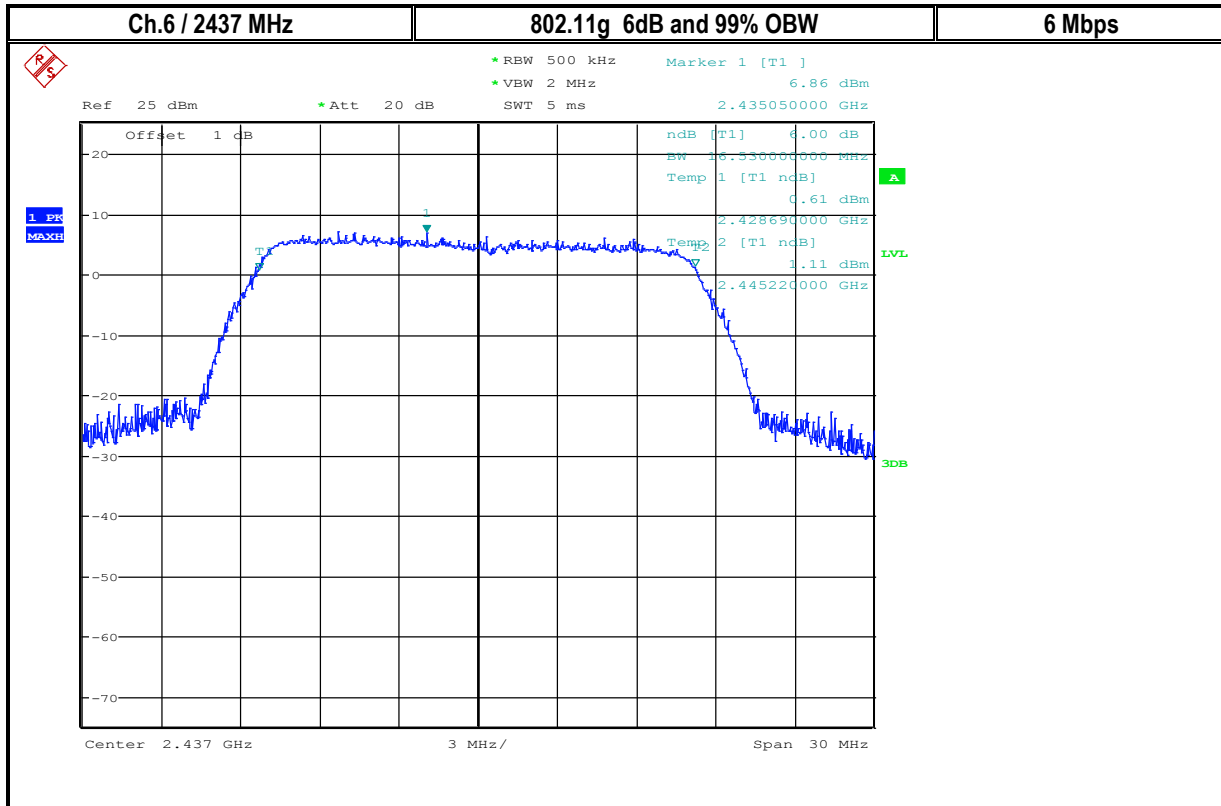



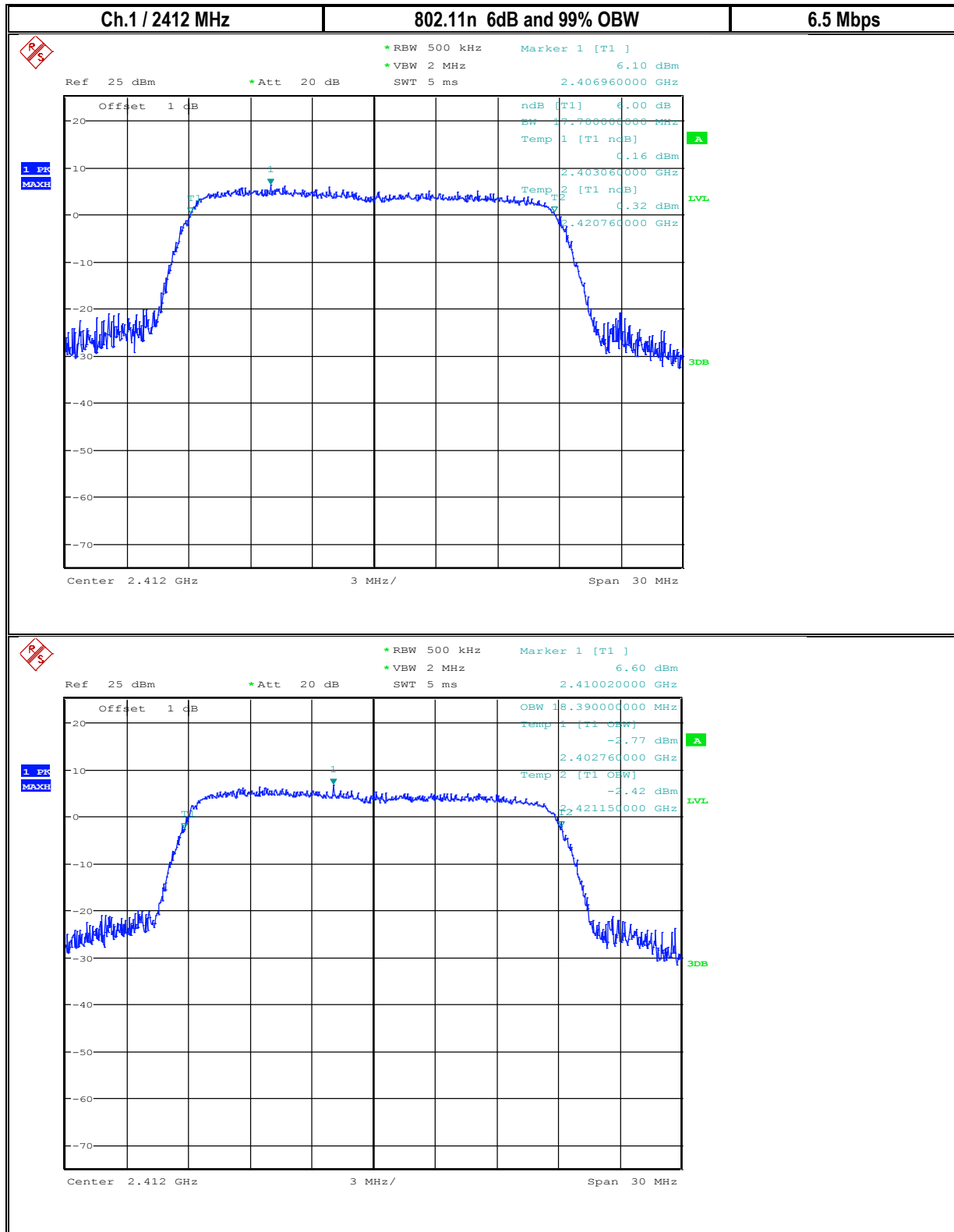

Date of Report : Dec. 14, 2016

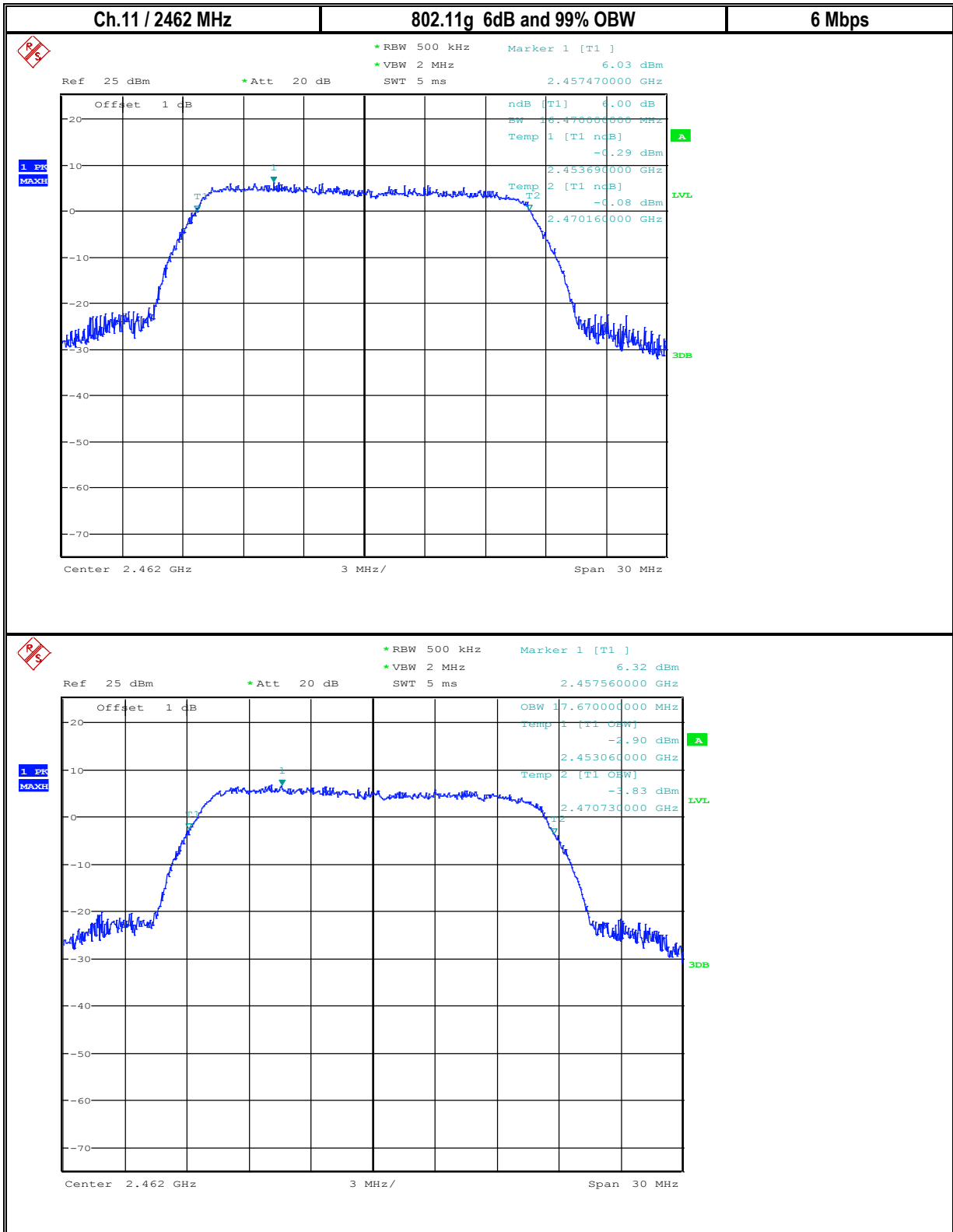

Date of Report : Dec. 14, 2016

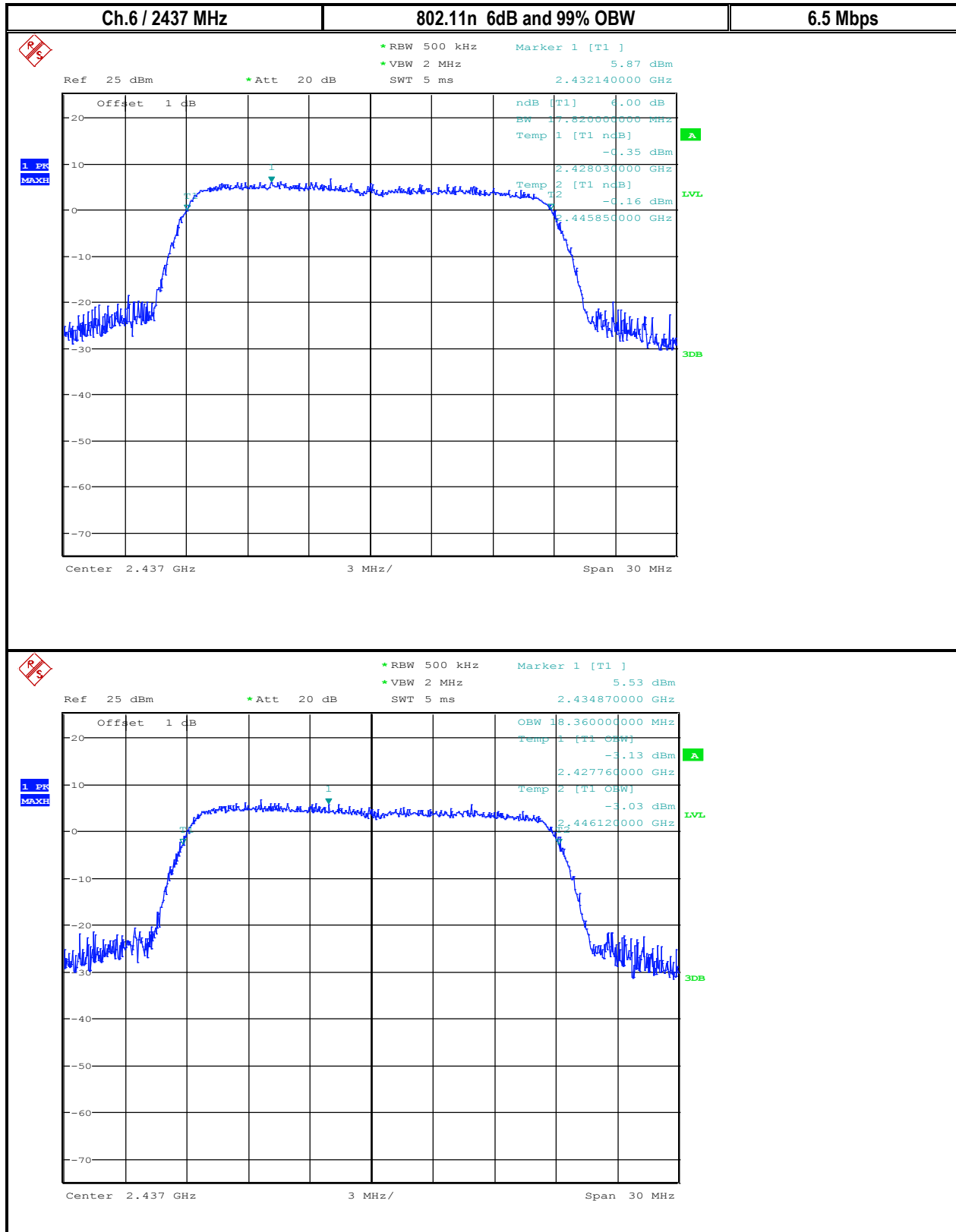

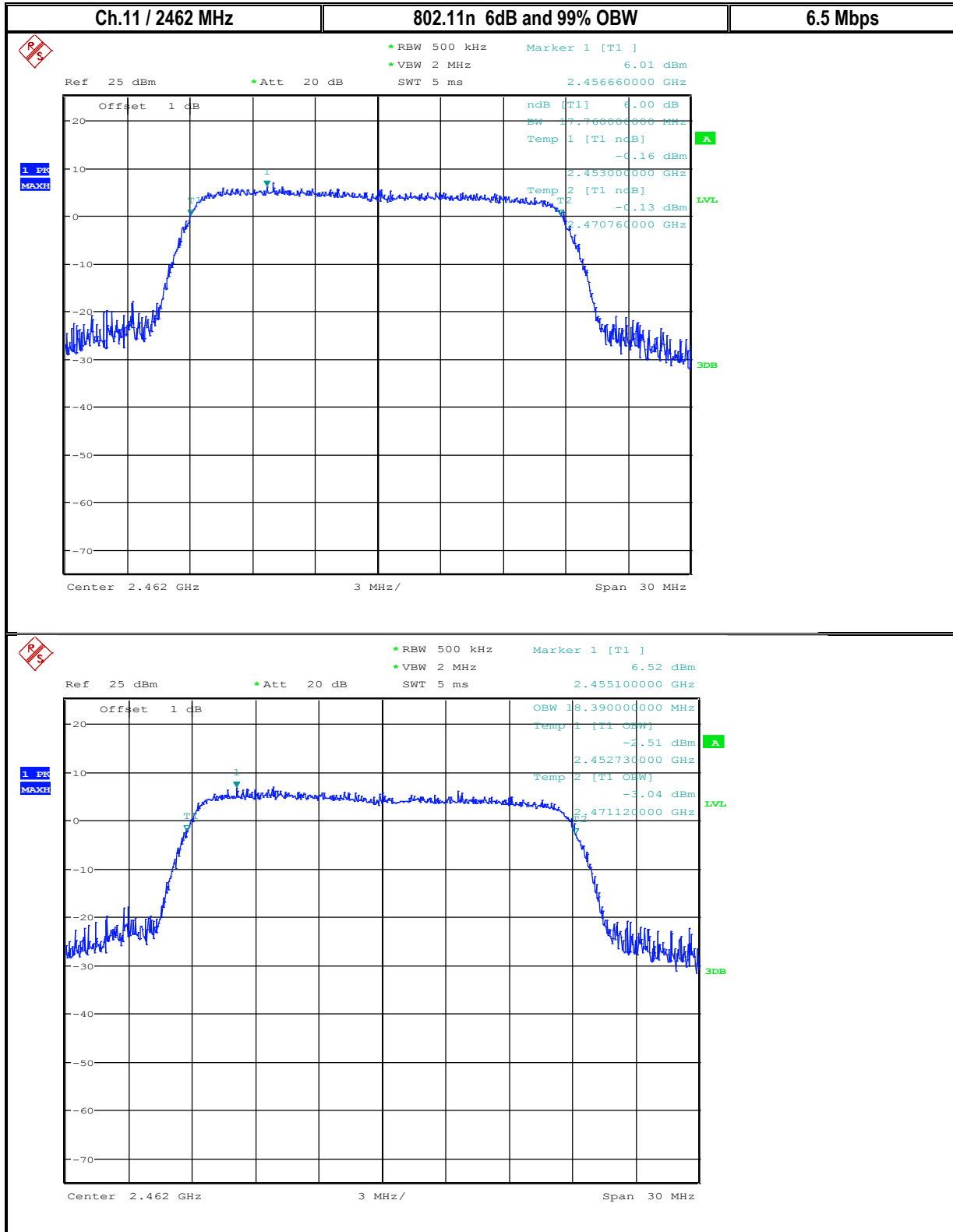

Date of Report : Dec. 14, 2016

### 8.3 Band Edge Compliance – at restricted and non-restricted band edges

#### 8.3.1 Limits:

§15.209/15.205/15.247 (d)

Only spurious emissions are permitted in any of the frequency bands listed below:

\*PEAK LIMIT= 74dBµV/m @3m =-21.23dBm

\*AVG. LIMIT= 54dBµV/m @3m =-41.23dBm

MHz	MHz	MHz	GHz
0.090 - 0.110	16.42 - 16.423	399.9 - 410	4.5 - 5.15
<sup>1</sup> 0.495 - 0.505	16.69475 - 16.69525	608 - 614	5.35 - 5.46
2.1735 - 2.1905	16.80425 - 16.80475	960 - 1240	7.25 - 7.75
4.125 - 4.128	25.5 - 25.67	1300 - 1427	8.025 - 8.5
4.17725 - 4.17775	37.5 - 38.25	1435 - 1626.5	9.0 - 9.2
4.20725 - 4.20775	73 - 74.6	1645.5 - 1646.5	9.3 - 9.5
6.215 - 6.218	74.8 - 75.2	1660 - 1710	10.6 - 12.7
6.26775 - 6.26825	108 - 121.94	1718.8 - 1722.2	13.25 - 13.4
6.31175 - 6.31225	123 - 138	2200 - 2300	14.47 - 14.5
8.291 - 8.294	149.9 - 150.05	2310 - 2390	15.35 - 16.2
8.362 - 8.366	156.52475 - 156.52525	2483.5 - 2500	17.7 - 21.4
8.37625 - 8.38675	156.7 - 156.9	2690 - 2900	22.01 - 23.12
8.41425 - 8.41475	162.0125 - 167.17	3260 - 3267	23.6 - 24.0
12.29 - 12.293	167.72 - 173.2	3332 - 3339	31.2 - 31.8
12.51975 - 12.52025	240 - 285	3345.8 - 3358	36.43 - 36.5
12.57675 - 12.57725	322 - 335.4	3600 - 4400	( <sup>2</sup> )
13.36 - 13.41			

Limits non restricted band §15.247

FCC15.247 (d) In any 100 kHz bandwidth outside the frequency band in which the spread spectrum or digitally modulated intentional radiator is operating, the radio frequency power that is produced by the intentional radiator shall be at least 20 dB below that in the 100 kHz bandwidth within the band that contains the highest level of the desired power, based on either an RF conducted or a radiated measurement, provided the transmitter demonstrates compliance with the peak conducted power limits. If the transmitter complies with the conducted power limits based on the use of RMS averaging over a time interval, as permitted under paragraph (b)(3) of this section, the attenuation required under this paragraph shall be 30 dB instead of 20 dB. Attenuation below the general limits specified in § 15.209(a) is not required. In addition, radiated emissions which fall in the restricted bands, as defined in § 15.205(a), must also comply with the radiated emission limits specified in § 15.209(a). (see §15.205(c)).

#### 8.3.2 Test Conditions:

Ambient Temperature	EUT Set-Up #	EUT operating mode	Power Input
21.4° C	2	Tx	Battery

### 8.3.3 Measurement Procedure:

These measurements are performed according to FCC KDB 558074 D01 DTS Measurement Guidance v03r05.

Per 11.1(b) As maximum conducted (average) output power was used to demonstrate compliance as described in 9.2, then the measured power in any 100 kHz bandwidth outside of the authorized frequency band shall be attenuated by at least 30 dB relative to the maximum in-band peak PSD level in 100 kHz (i.e. -30 dBc).

Measurement method to establish reference

- a) Set instrument center frequency to DTS channel center frequency.
- b) Set the span to  $\geq 1.5$  times the DTS bandwidth.
- c) Set the RBW = 100 kHz.
- d) Set the VBW  $\geq 3 \times$  RBW.
- e) Detector = peak.
- f) Sweep time = auto couple.
- g) Trace mode = max hold.
- h) Allow trace to fully stabilize.
- i) Use the peak marker function to determine the maximum PSD level.

The Lower band edge emissions measured using average power measurements are shown to be -30dBc relative to the reference signal level, and per the KDB, If the peak-detected amplitude can be shown to comply with the average limit, then it is not necessary to perform a separate average measurement.

Since high band edge (2483.5MHz) falls next to the restricted band (2483.5-2500MHz), it is measured as a restricted band. Measurements made according to KDB 558074 D01 Section 12.2.5.2 Trace averaging across on and off times of the EUT transmissions followed by duty cycle correction.

Date of Report : Dec. 14, 2016

8.3.4 Measurement Result:

Plot #	EUT operating mode	Band Edge	Band Edge Delta (dBc)	Limit (dBc) in case average output power measured	Result
1	802.11b	Lower, non-restricted	-38.64	-30	Pass
2	802.11g	Lower, non-restricted	-36.96	-30	Pass
3	802.11n	Lower, non-restricted	-37.67	-30	Pass

Plot #	EUT operating mode	Band Edge	Measured value	Corrected by Duty Cycle Correction Factor (dBm)	Corrected by Antenna Gain (1 dBi)	Limit (dBm)	Result
4	802.11b	Upper restricted average	-51.36	-51.36	-50.36	-41.23 avg	Pass
5	802.11g	Upper restricted Average	-49.67	-49.54	-48.54	-41.23 avg	Pass
6	802.11n	Upper restricted average	-49.2	-49.07	-48.07	-41.23 avg	Pass
7	802.11b	Upper restricted Peak	-43.04	-43.04	-42.04	-21.23 Peak	Pass
8	802.11g	Upper restricted Peak	-30.3	-30.17	-29.17	-21.23 Peak	Pass
9	802.11n	Upper restricted Peak	-30.9	-30.77	-29.77	-21.23 Peak	Pass

Date of Report : Dec. 14, 2016

8.4 Test Data/plots: 2.4 GHz Band

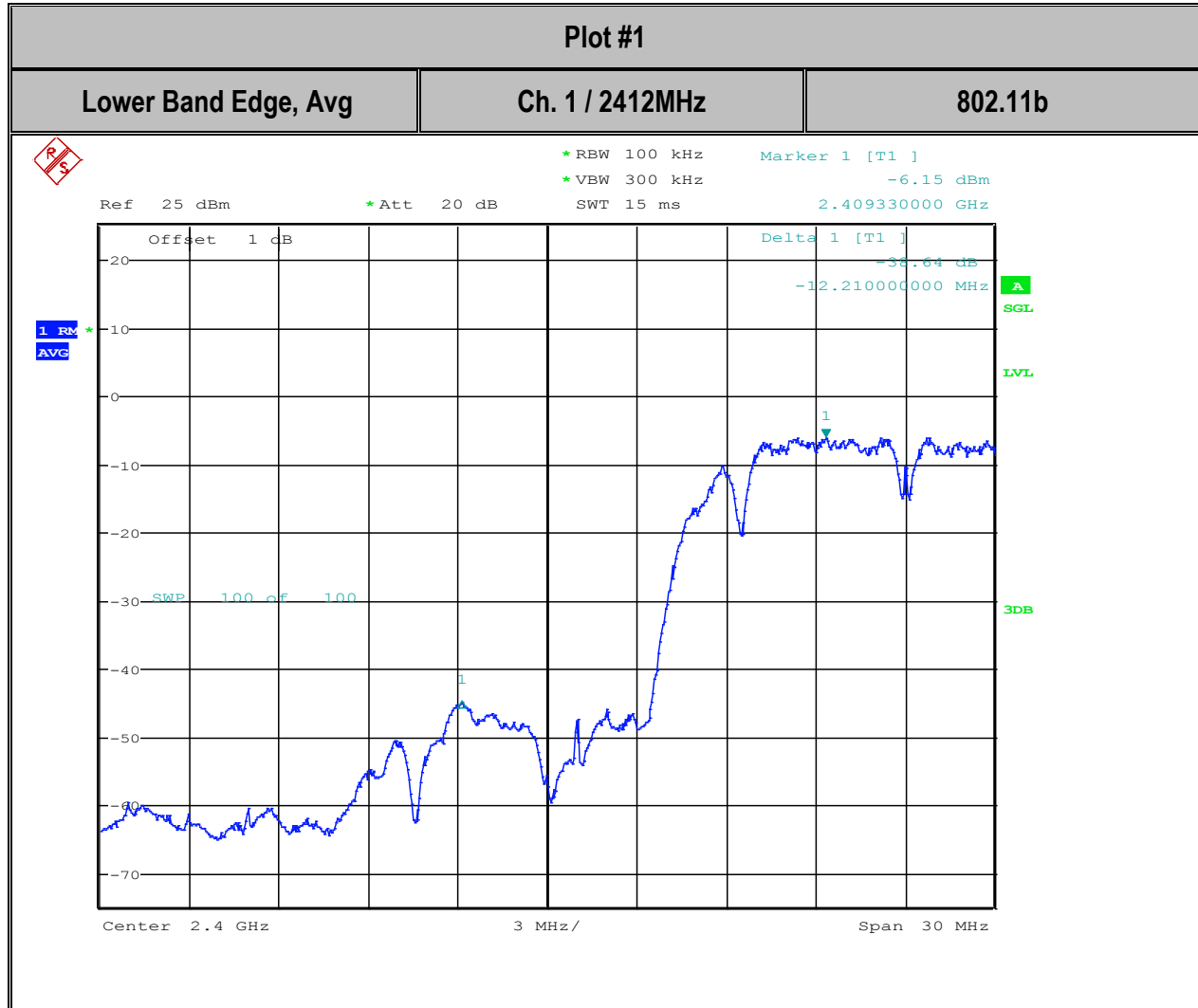



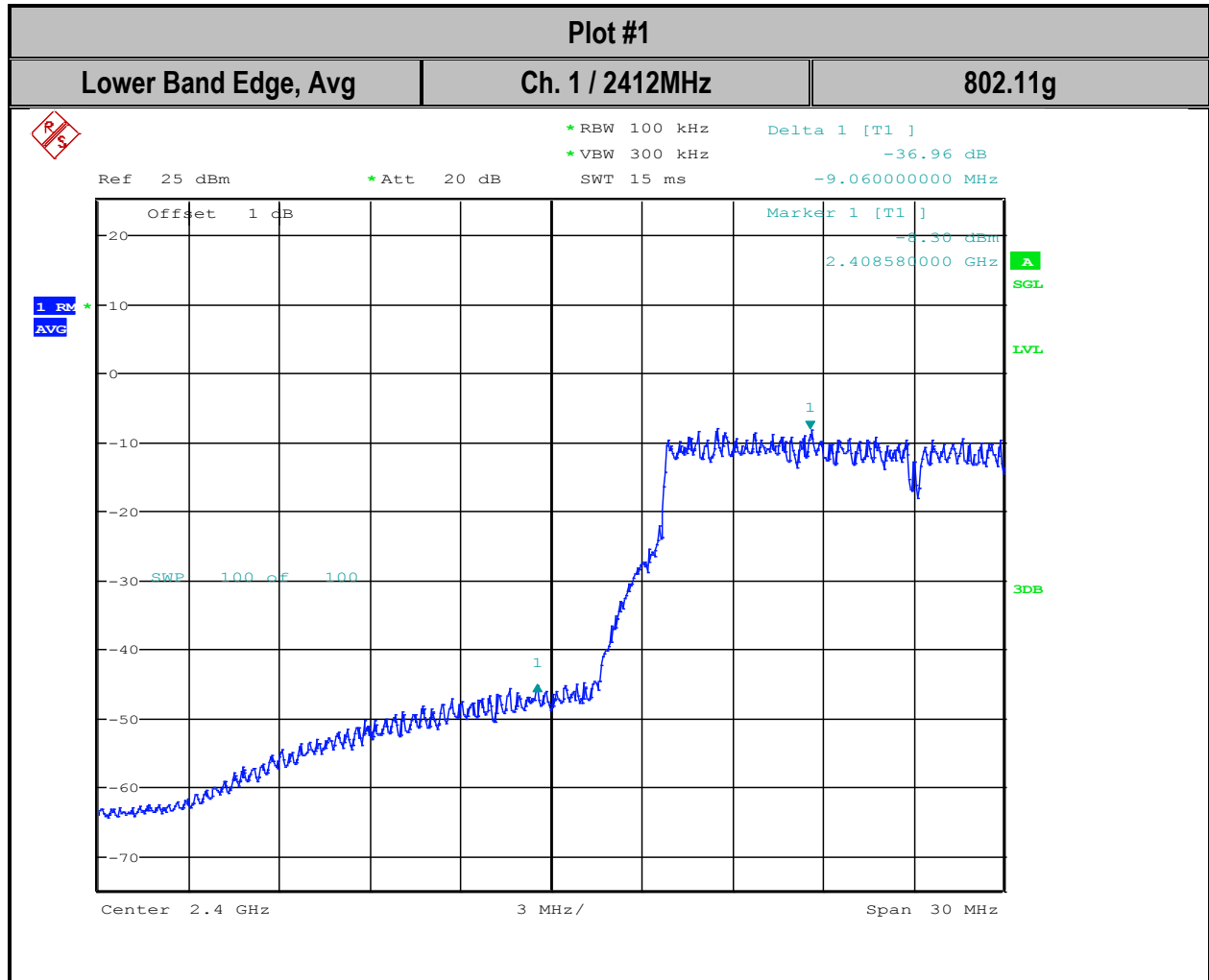

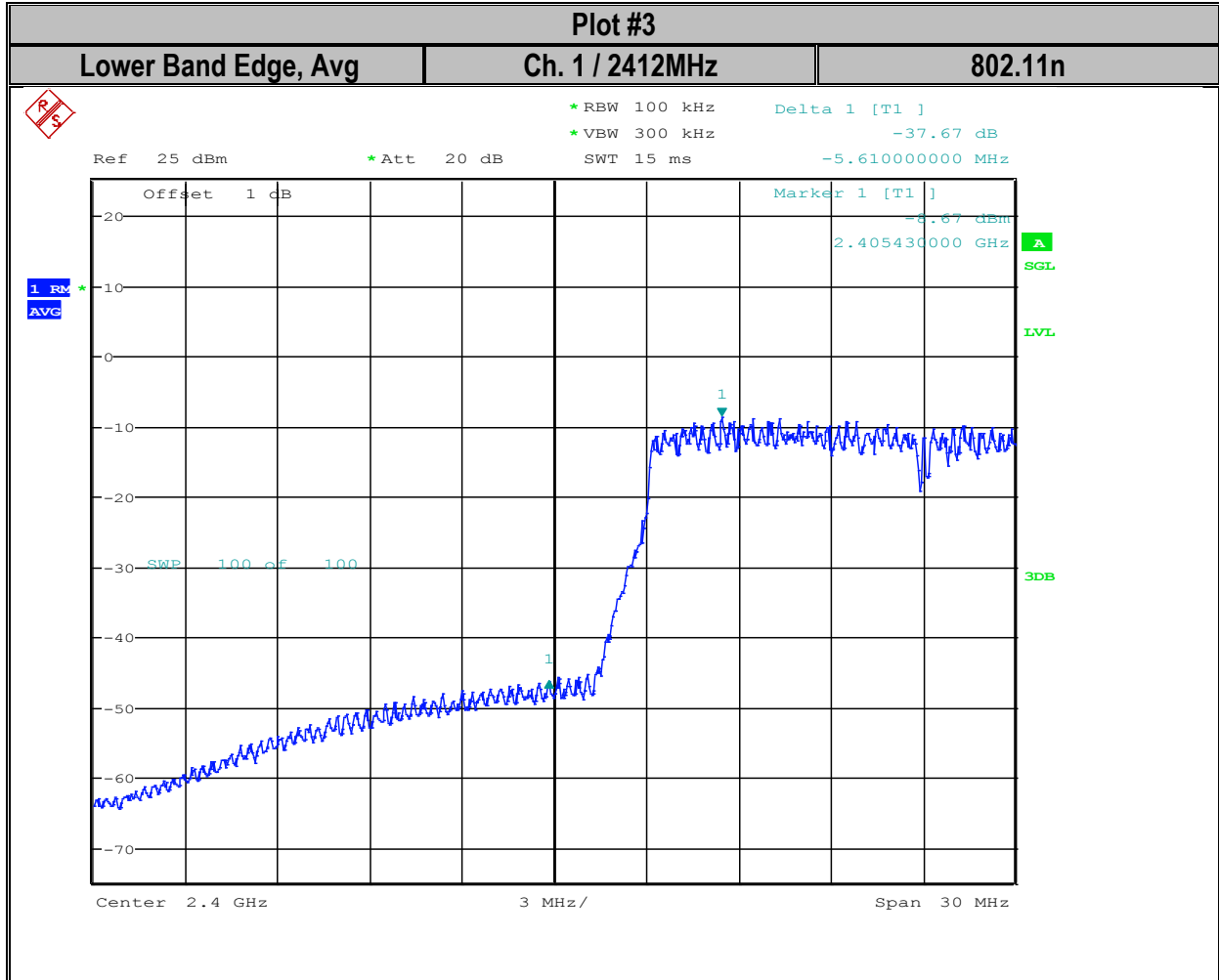

8.4.1 Restricted Band Plots

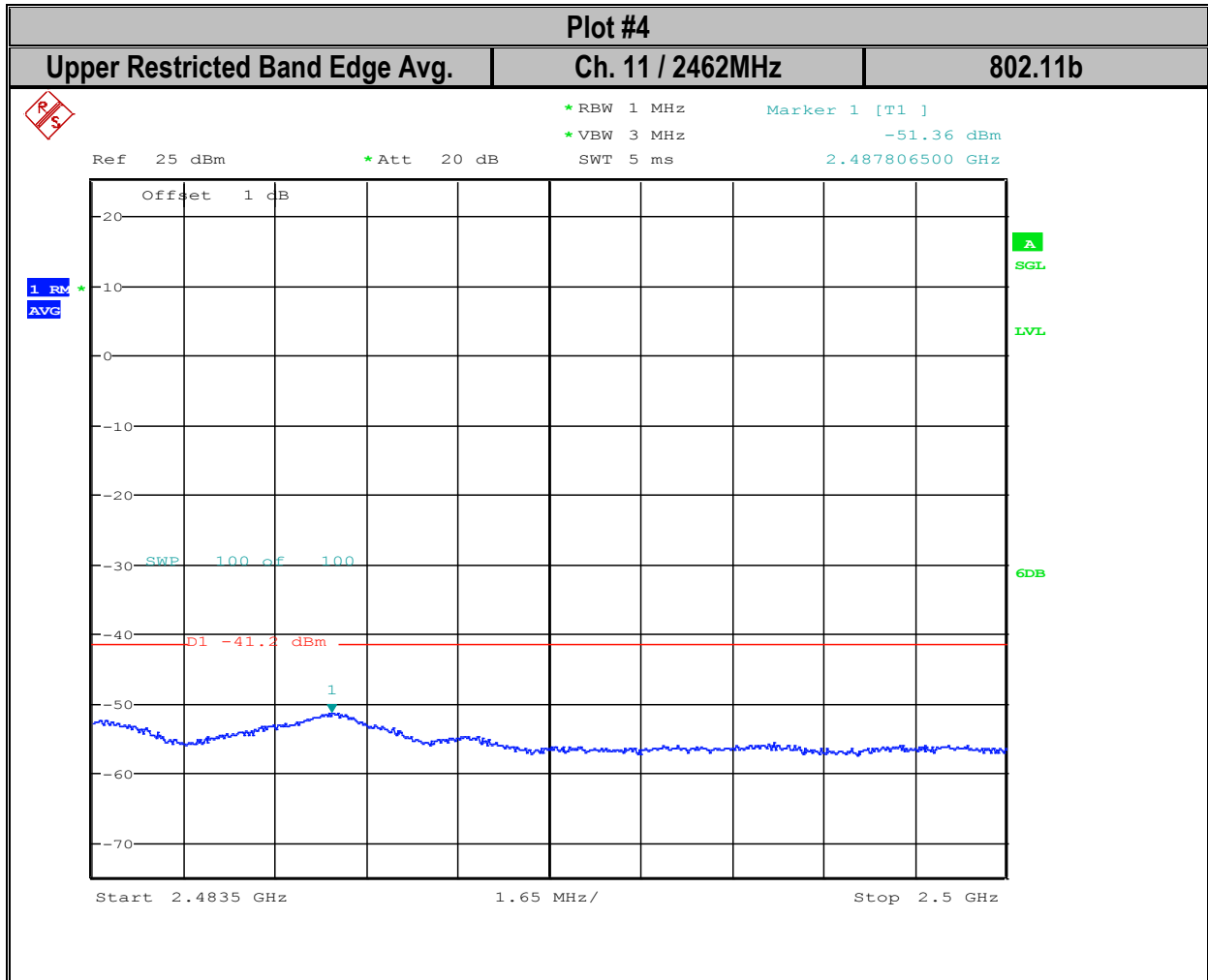

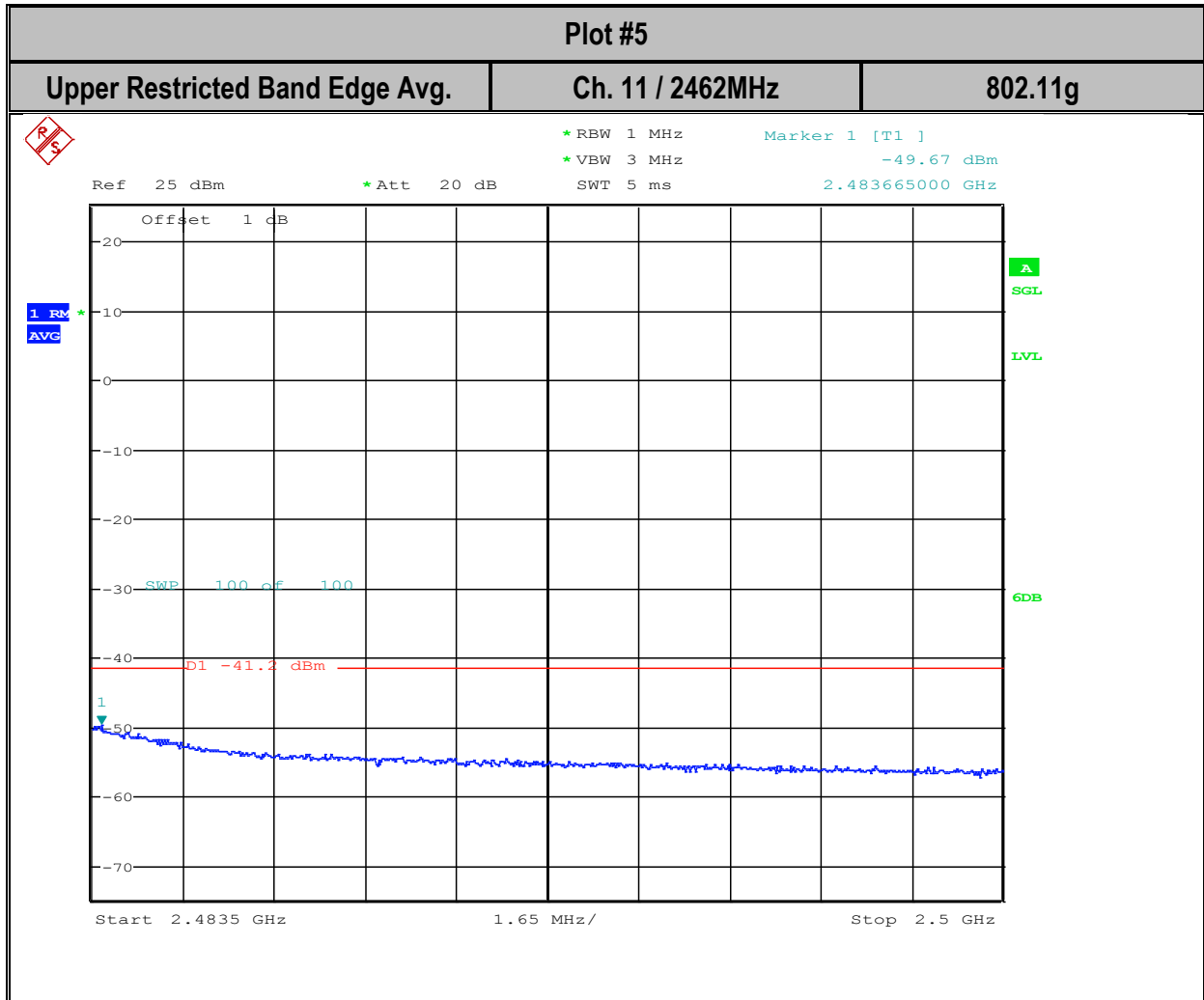

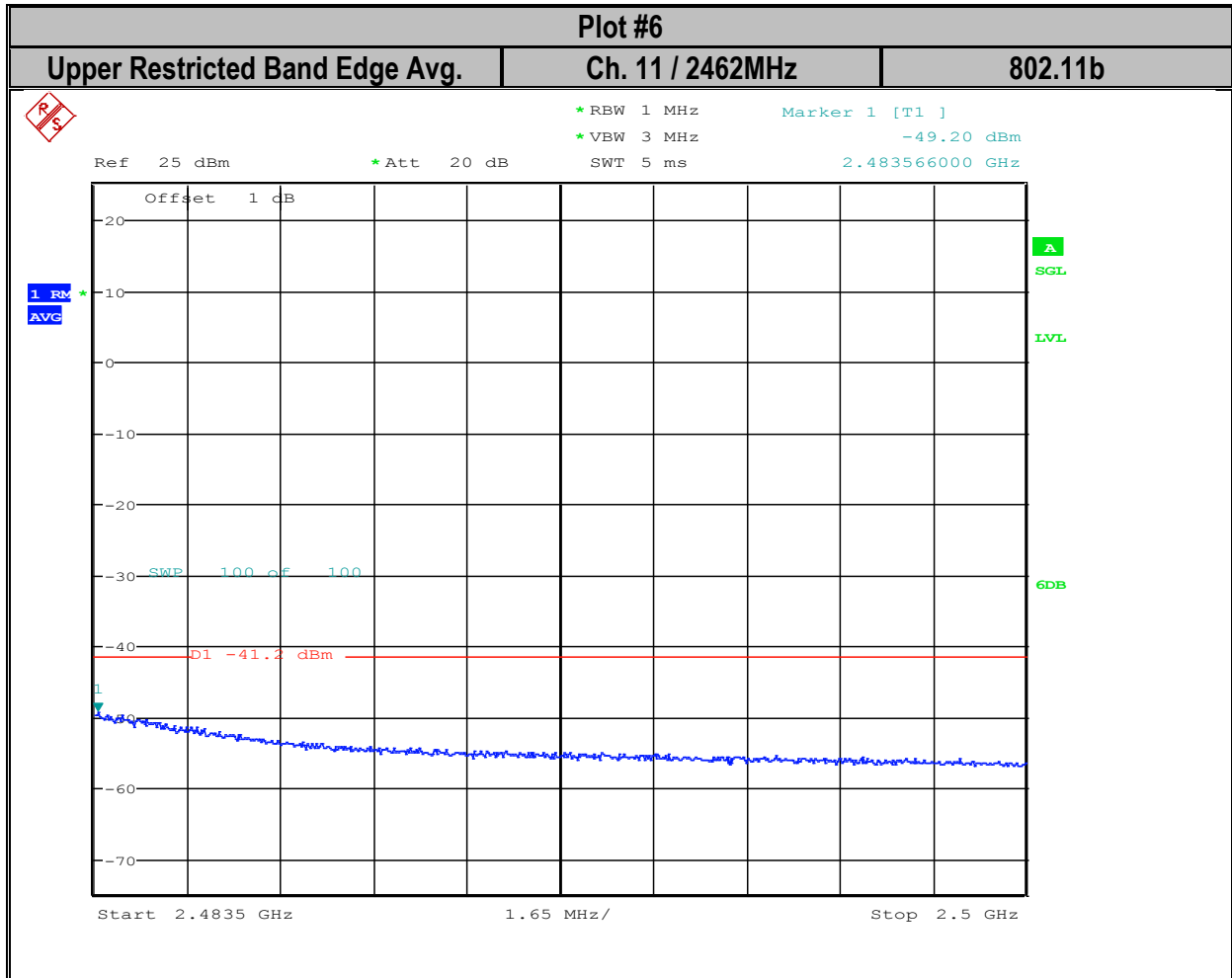

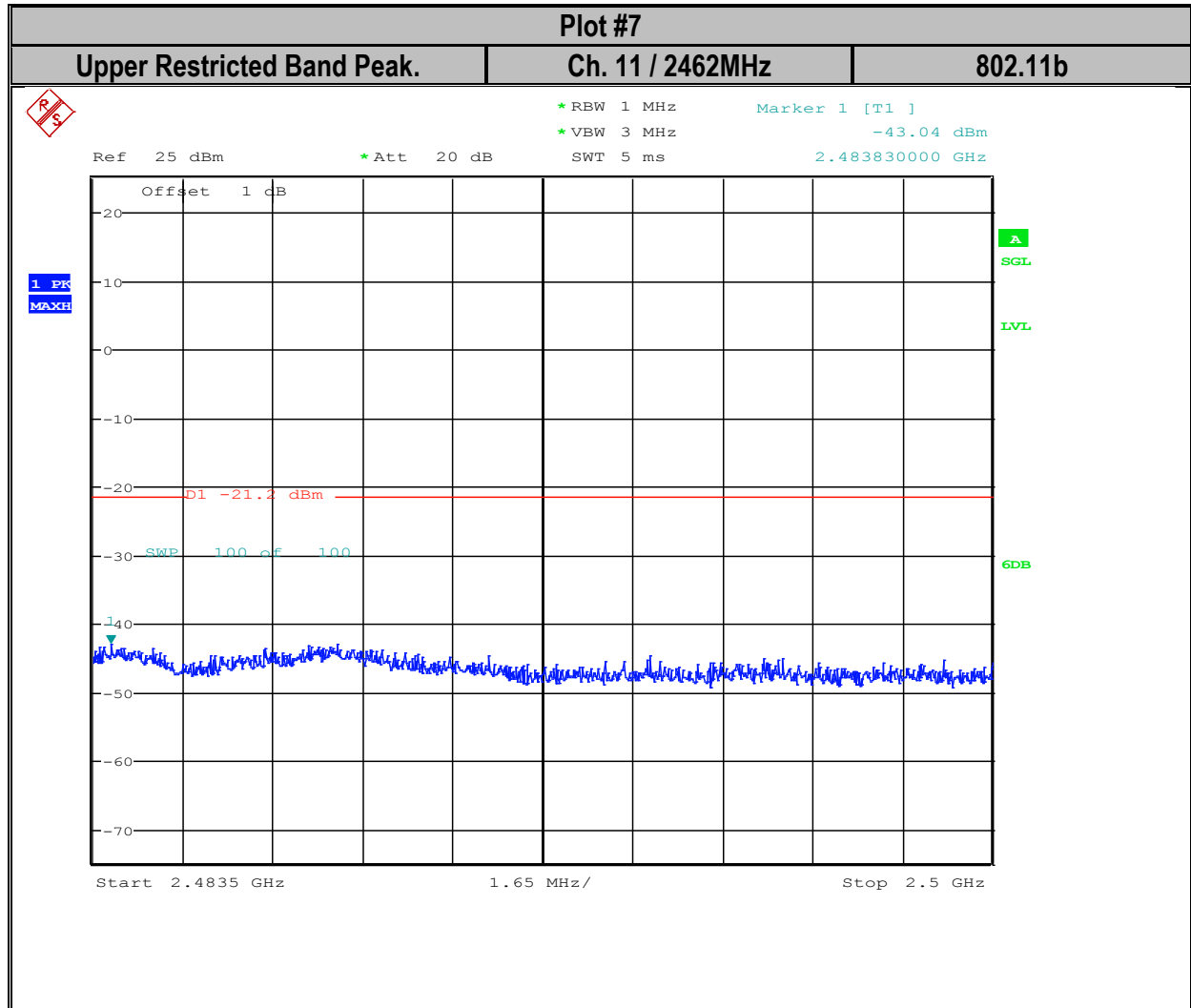

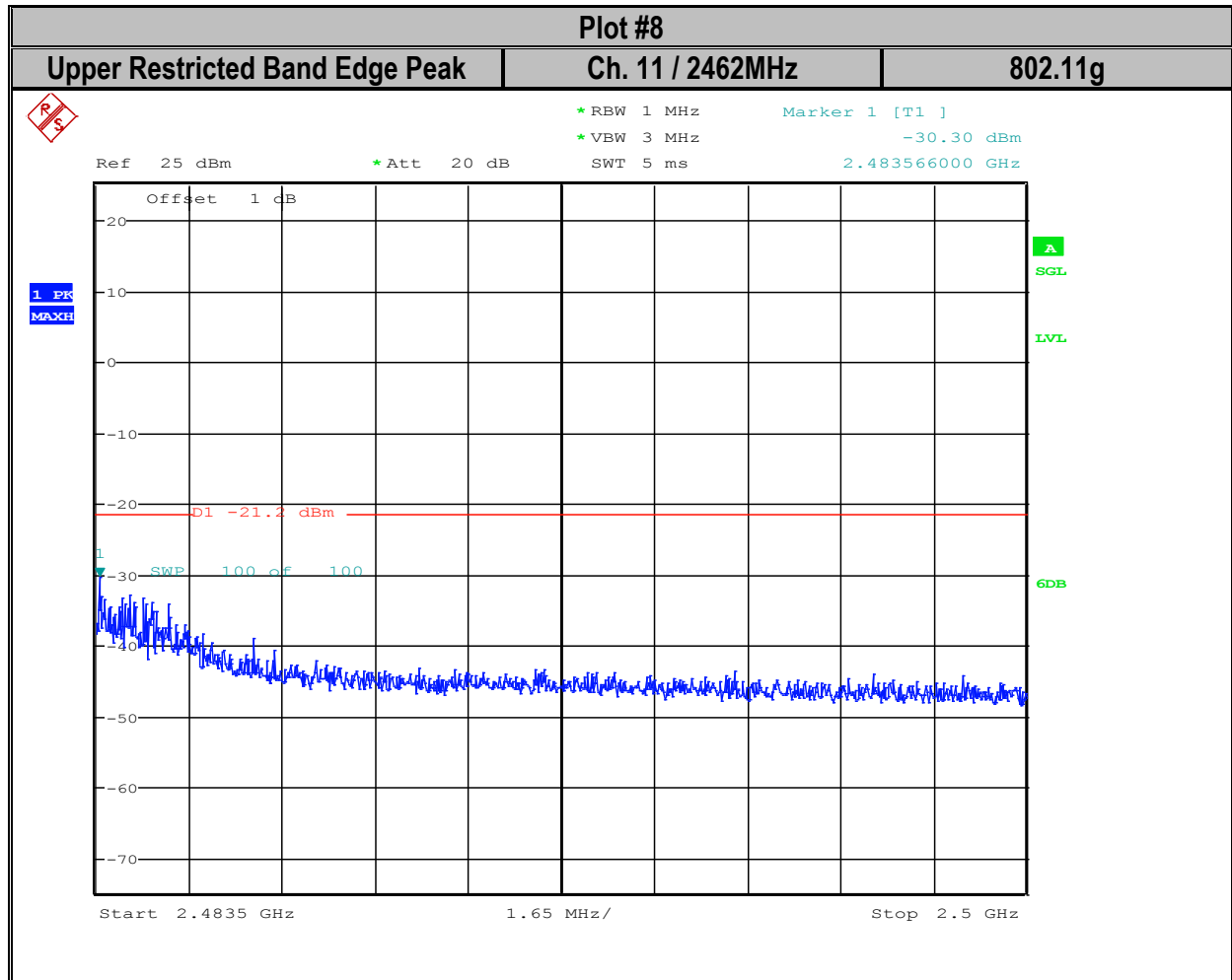

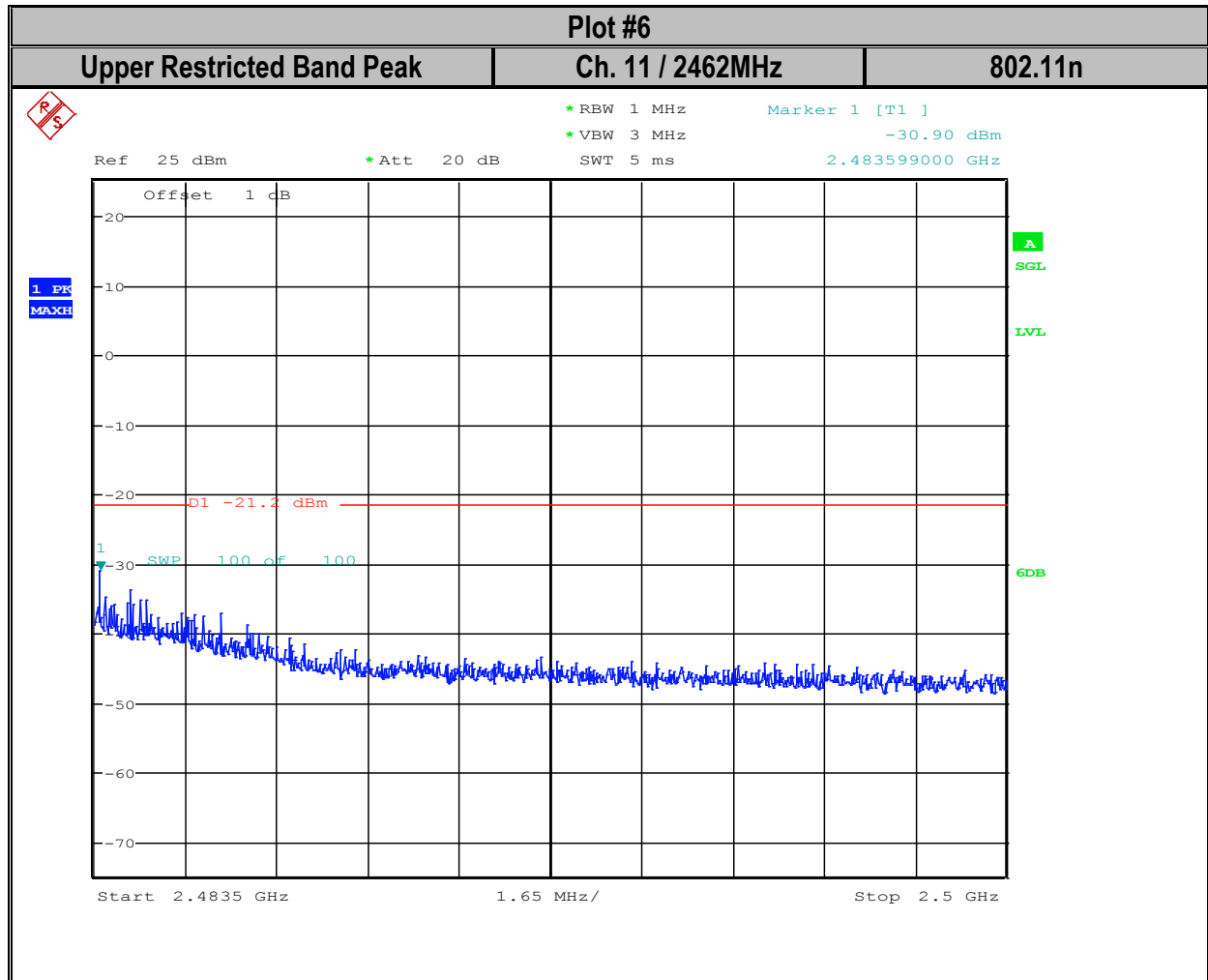



Date of Report : Dec. 14, 2016

---

8.5 Power Spectral Density

8.5.1 Selection of applicable test method

The DTS rules specify a conducted PSD limit within the DTS bandwidth during any time interval of continuous transmission. Such specifications require that the same method as used to determine the conducted output power shall also be used to determine the power spectral density

Hence method selected was per KDB 558074 v03r05 Section 10.5. Method AVGPSD-2 (trace averaging across on and off times of the EUT transmissions, followed by duty cycle correction

8.5.2 Limits:

§ 15.247 (e) For digitally modulated systems, the peak power spectral density conducted from the intentional radiator to the antenna shall not be greater than 8dBm in any 3 kHz band during any time interval of continuous transmission.

8.5.3 Test Conditions:

Ambient Temperature	EUT Set-Up #	EUT operating mode	Power Input
23.6 ° C	2	Tx	Battery

8.5.4 Measurement procedure:

Measurement according to FCC KDB 558074 D01 DTS v03r05 section 10.2

1. Set analyzer center frequency to DTS channel center frequency.
2. Set the span to at least 1.5 x the OBW
3. Set the RBW  $3 \text{ kHz} \leq \text{RBW} \leq 100 \text{ kHz}$ . =3 kHz,
4. VBW  $\geq 3 \times \text{RBW}$  and sweep time = auto.
5. Detector = power averaging (RMS) or sample detector (when RMS not available).
6. Employ trace averaging (RMS) mode over a minimum of 100 traces.
7. Use the peak marker function to determine the maximum amplitude level
8. Duty Cycle Correction
9. Compare with limits

Date of Report : Dec. 14, 2016

**8.5.5 Test Data: 2.4 GHz Band**

Conducted Power Spectral Density (dBm)			
Mode	Frequency (MHz)		
	2412 Channel 1	2437 Channel 6	2462 Channel 11
802.11b	0.27	0.67	-0.03
802.11g	-4.00	-3.57	-3.59
802.11n	-3.80	-4.28	-3.41

DC Correction Power Spectral Density (dBm)				
Mode	Frequency (MHz)			
	2412 Channel 1	2437 Channel 6	2462 Channel 11	Limit
802.11b	0.27	0.67	-0.03	8 dBm
802.11g	-3.87	-3.44	-3.46	8 dBm
802.11n	-3.67	-4.15	-3.28	8 dBm

8.5.6 Measurement Result  
Pass.

Date of Report : Dec. 14, 2016

### 8.5.7 Measurement Plots: 2.4 GHz Band Power Spectral Density 802.11b 2412 MHz

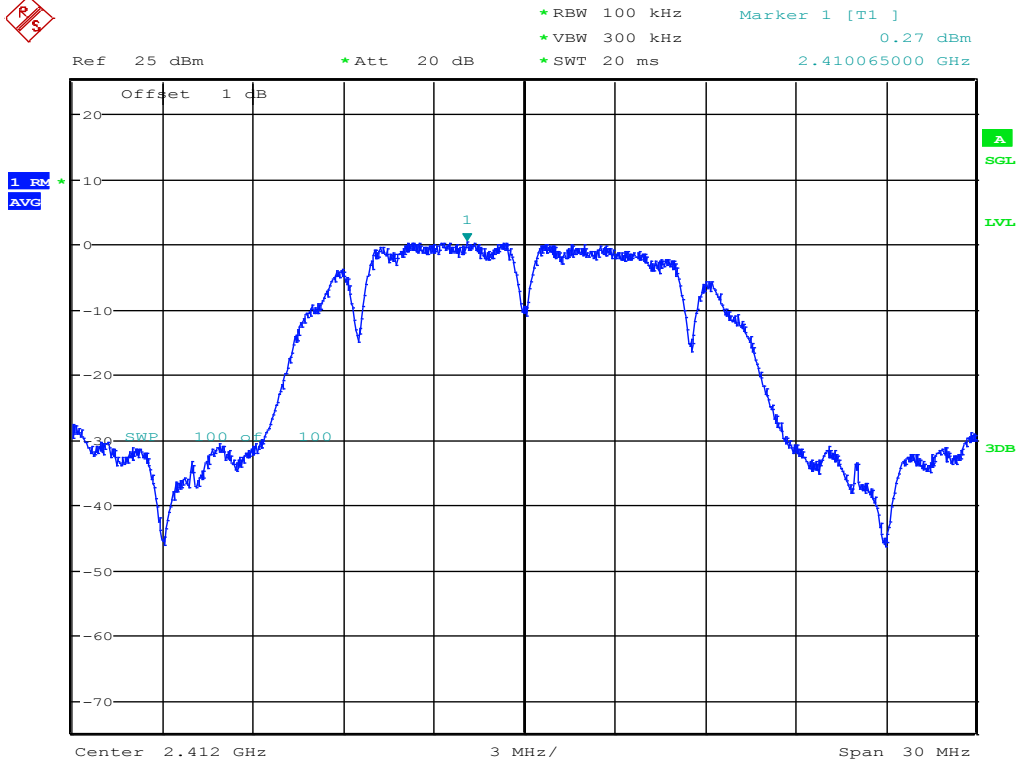

### Power Spectral Density 802.11b 2437 MHz

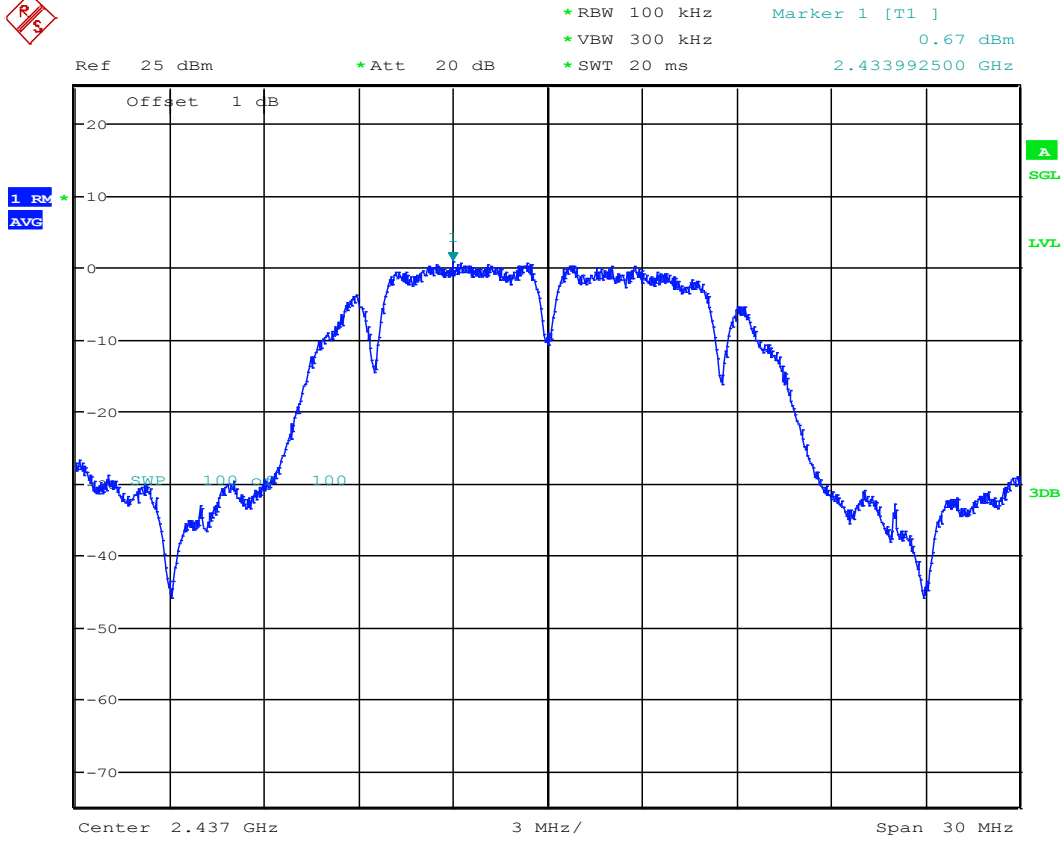

### Power Spectral Density 802.11b 2462 MHz

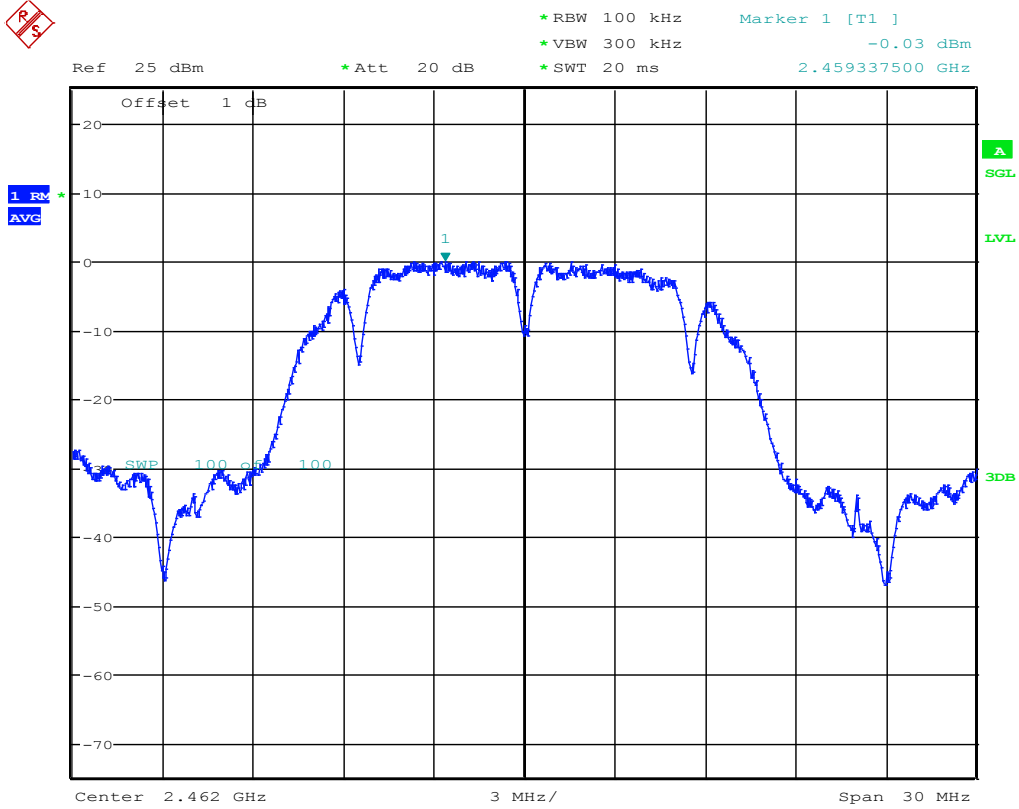

Date of Report : Dec. 14, 2016

### Power Spectral Density 802.11g 2412 MHz

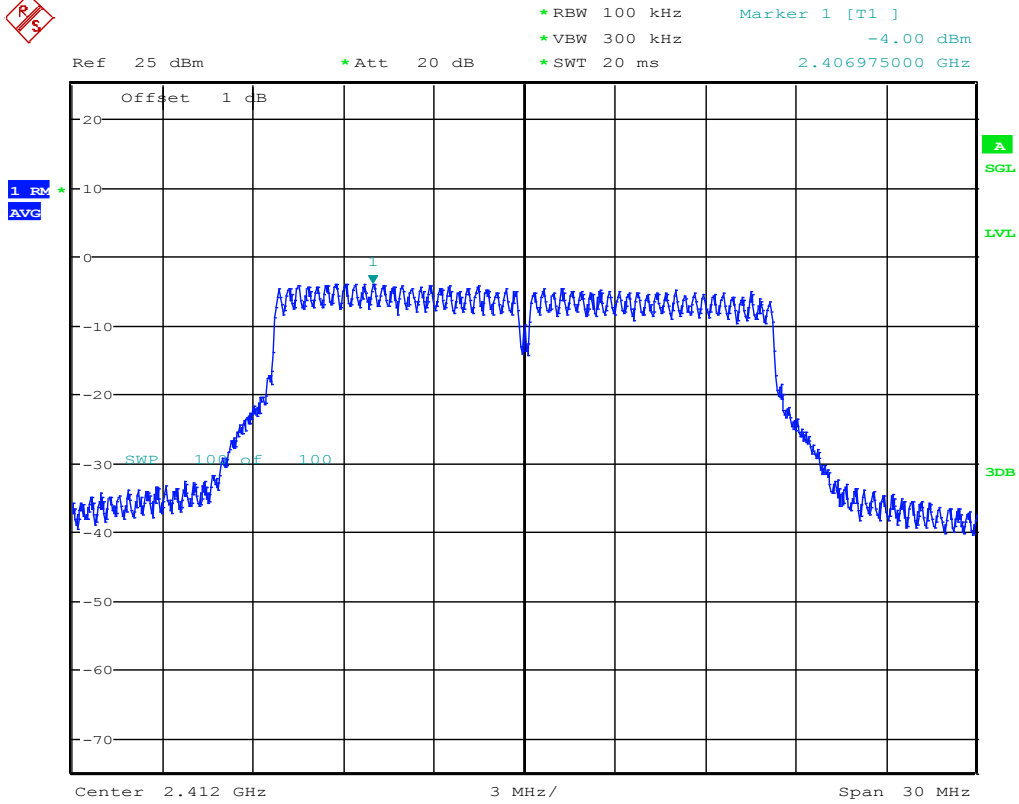

Date of Report : Dec. 14, 2016

### Power Spectral Density 802.11g 2437 MHz

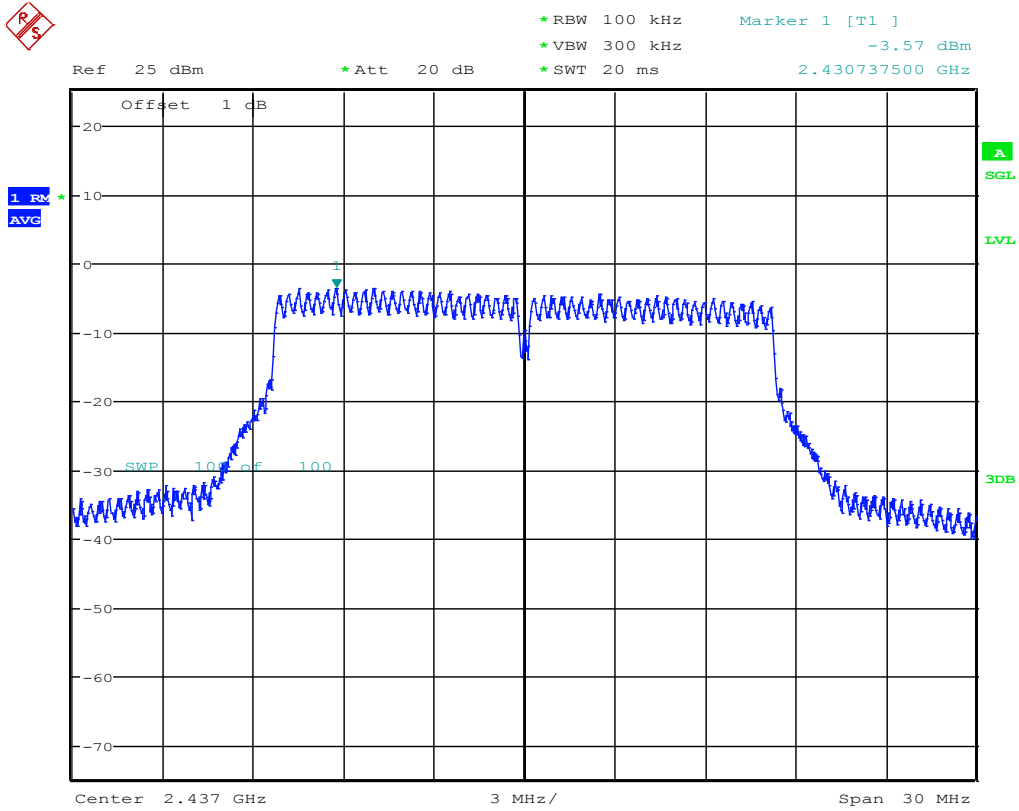

### Power Spectral Density 802.11g 2462 MHz

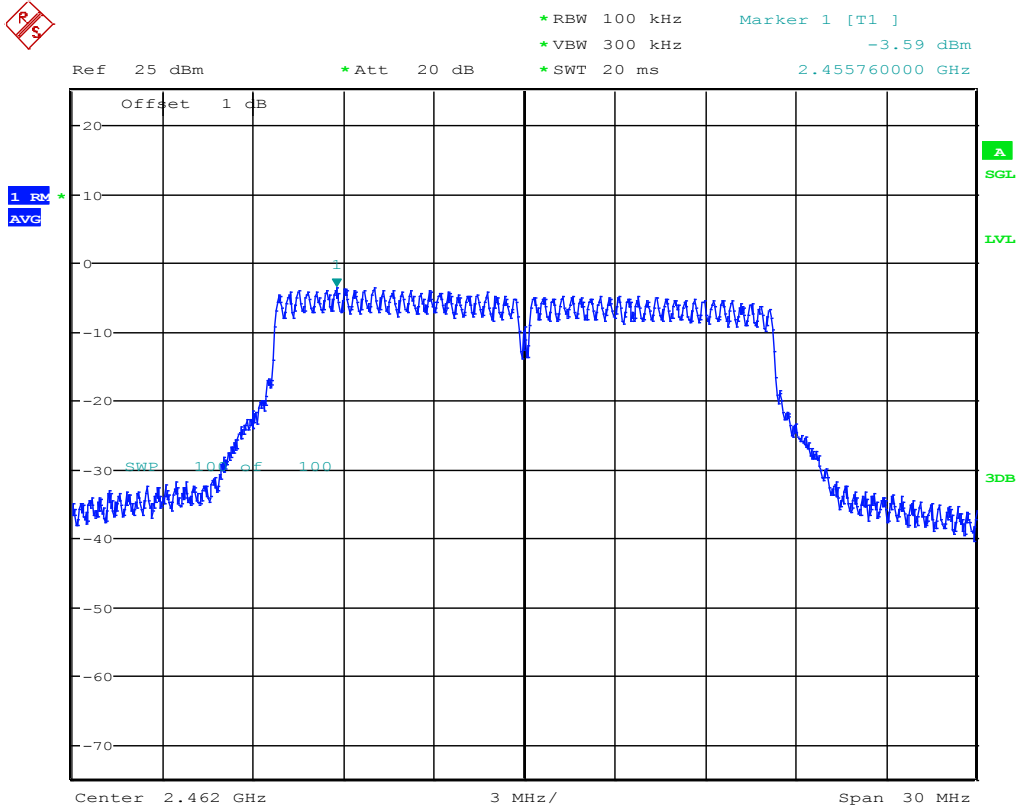



**Power Spectral Density 802.11n -MCS0 (20MHz) 2412 MHz**

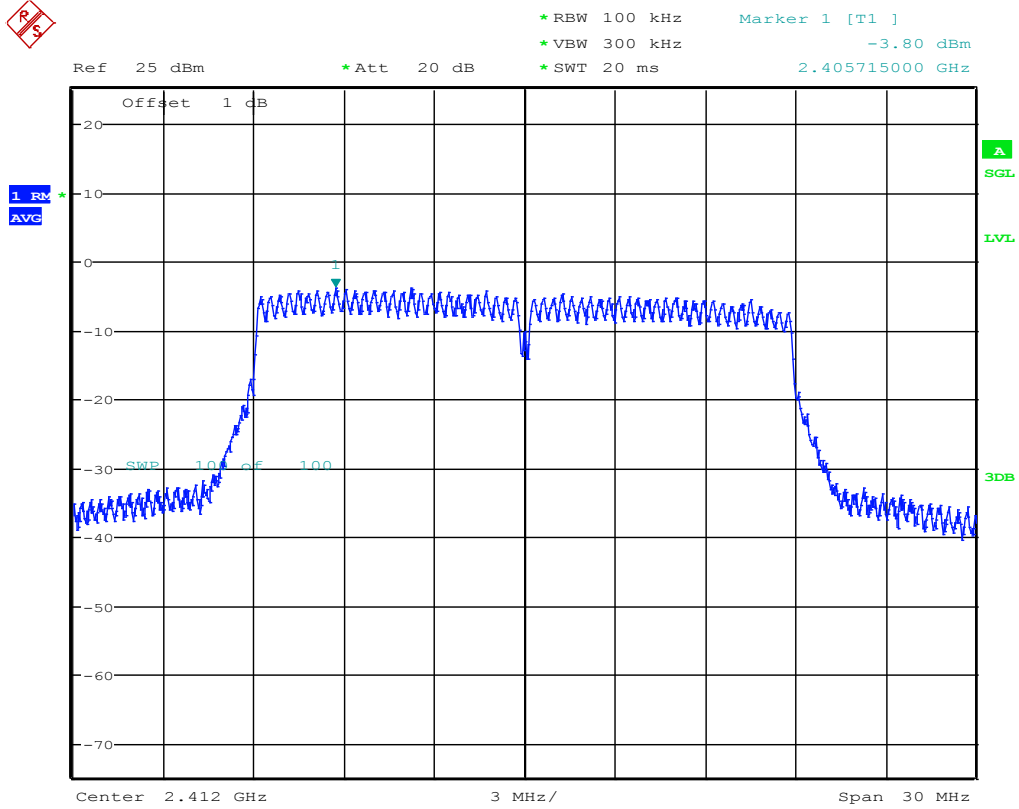

**Power Spectral Density 802.11n -MCS0 (20MHz) 2437 MHz**

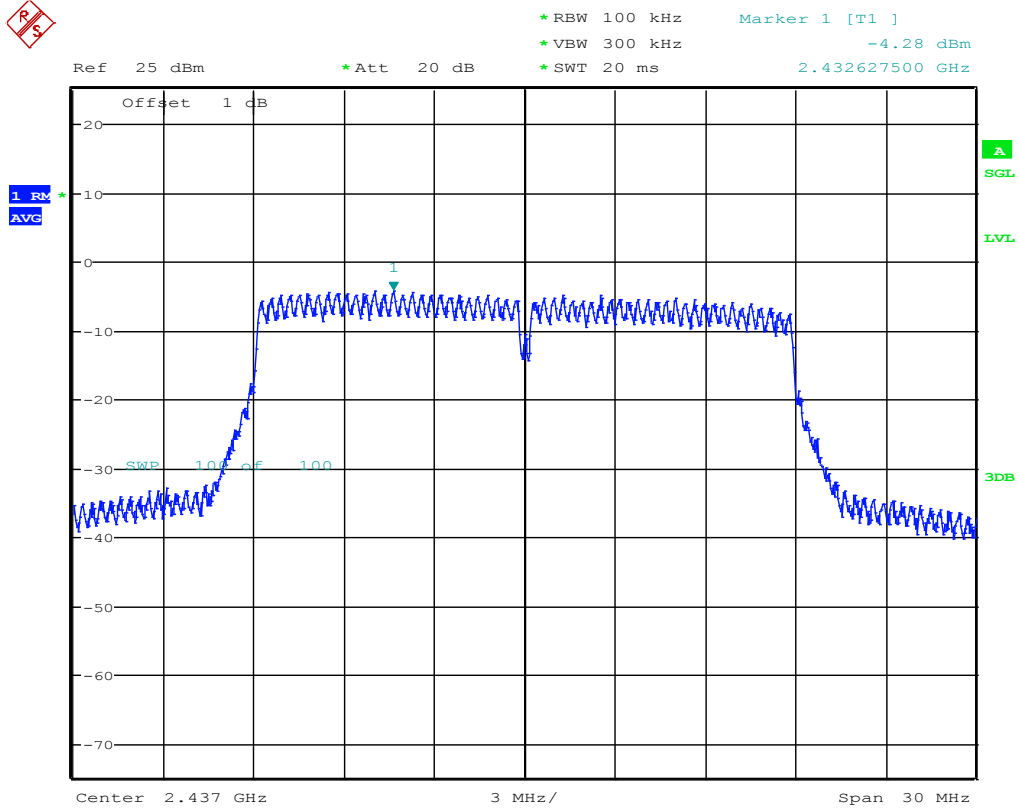

**Power Spectral Density 802.11n -MCS0 (20MHz) 2462 MHz**

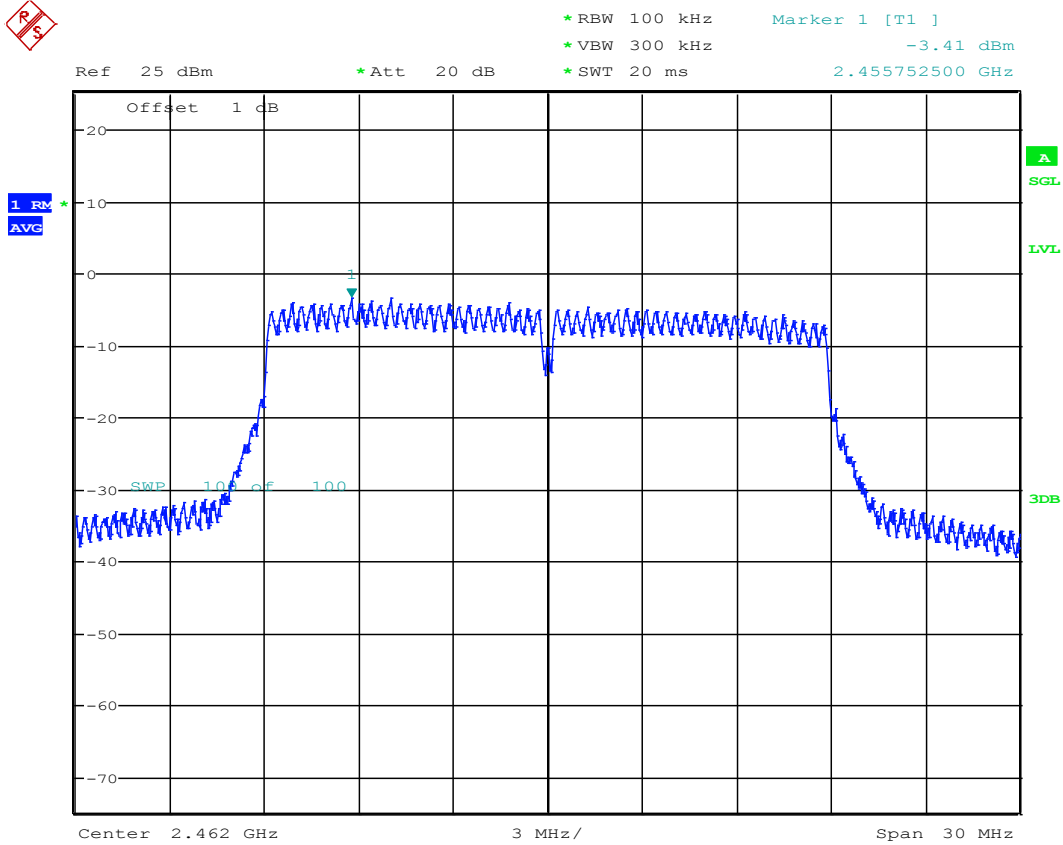

Date of Report : Dec. 14, 2016

8.6 Radiated Transmitter Spurious Emissions:

8.6.1 Measurement Procedure

Measurements according to ANSI C63.10 (2013)

Analyzer Settings:

Frequency = 9 KHz – 30 MHz

RBW = 9 KHz,

Detector: Peak

Frequency = 30 MHz – 1 GHz

Detector = Peak / Quasi-Peak ,

RBW=120 KHz (<1GHz)

Frequency > 1 GHz

Detector = Peak / Average,

RBW= 1MHz

Plots reported here represent the worst case emissions for horizontal and vertical antenna polarizations and orientations of the EUT. Unless mentioned otherwise, the emissions outside the limit lines in the plots are from the transmit signal.

8.6.2 Limits:

§15.247/15.205/15.209

Only spurious emissions are permitted in any of the frequency bands listed below:

MHz	MHz	MHz	GHz
0.090 - 0.110	16.42 - 16.423	399.9 - 410	4.5 - 5.15
<sup>1</sup> 0.495 - 0.505	16.69475 - 16.69525	608 - 614	5.35 - 5.46
2.1735 - 2.1905	16.80425 - 16.80475	960 - 1240	7.25 - 7.75
4.125 - 4.128	25.5 - 25.67	1300 - 1427	8.025 - 8.5
4.17725 - 4.17775	37.5 - 38.25	1435 - 1626.5	9.0 - 9.2
4.20725 - 4.20775	73 - 74.6	1645.5 - 1646.5	9.3 - 9.5
6.215 - 6.218	74.8 - 75.2	1660 - 1710	10.6 - 12.7
6.26775 - 6.26825	108 - 121.94	1718.8 - 1722.2	13.25 - 13.4
6.31175 - 6.31225	123 - 138	2200 - 2300	14.47 - 14.5
8.291 - 8.294	149.9 - 150.05	2310 - 2390	15.35 - 16.2
8.362 - 8.366	156.52475 - 156.52525	2483.5 - 2500	17.7 - 21.4
8.37625 - 8.38675	156.7 - 156.9	2690 - 2900	22.01 - 23.12
8.41425 - 8.41475	162.0125 - 167.17	3260 - 3267	23.6 - 24.0
12.29 - 12.293	167.72 - 173.2	3332 - 3339	31.2 - 31.8
12.51975 - 12.52025	240 - 285	3345.8 - 3358	36.43 - 36.5
12.57675 - 12.57725	322 - 335.4	3600 - 4400	( <sup>2</sup> )
13.36 - 13.41			

Radiated emissions which fall in the restricted bands, as defined in §15.205(a), must also comply with the radiated emission limits specified in §15.209(a) (see §15.205(c)).

\*PEAK LIMIT= 74dBµV/m and

\*AVG. LIMIT= 54dBµV/m

Date of Report : Dec. 14, 2016

Table 1:

Frequency of emission (MHz)	Field strength (μV/m)
30–88	100 (40dBμV/m)
88–216	150 (43.5 dBμV/m)
216–960	200 (46 dBμV/m)
Above 960	500 (54 dBμV/m, average) (Peak limit: 54 dBμV/m,)

Table 2:

Frequency of emission (MHz)	Field strength (μV/m)	Measurement Distance (m)
0.009–0.490	2400/F(kHz)	300
0.490–1.705	24000/F(kHz)	30
1.705–30.0	30	30

8.6.3 Test Conditions:

Ambient Temperature	EUT Set-Up #	EUT operating mode	Power Input
23.4° C	1	Tx	Battery

8.6.4 Measurement procedure:

Measurement according to ANSI C63.10:2013 (also refer to section 6.1 in this test report)

8.6.5 Test Result:

Unless mentioned otherwise, the emissions outside the limit lines in the plots are from the transmit signal.

Plots reported here represent the worst case emissions for horizontal and vertical antenna polarizations and orientations of the EUT.

8.6.6 Measurement Result

Pass.

Date of Report : Dec. 14, 2016

8.6.7 Test data/ plots: 2.4 GHz Band

**Transmitter Radiated Spurious Emission: Ch Mid- 9kHz – 30MHz- 802.11b-mode**

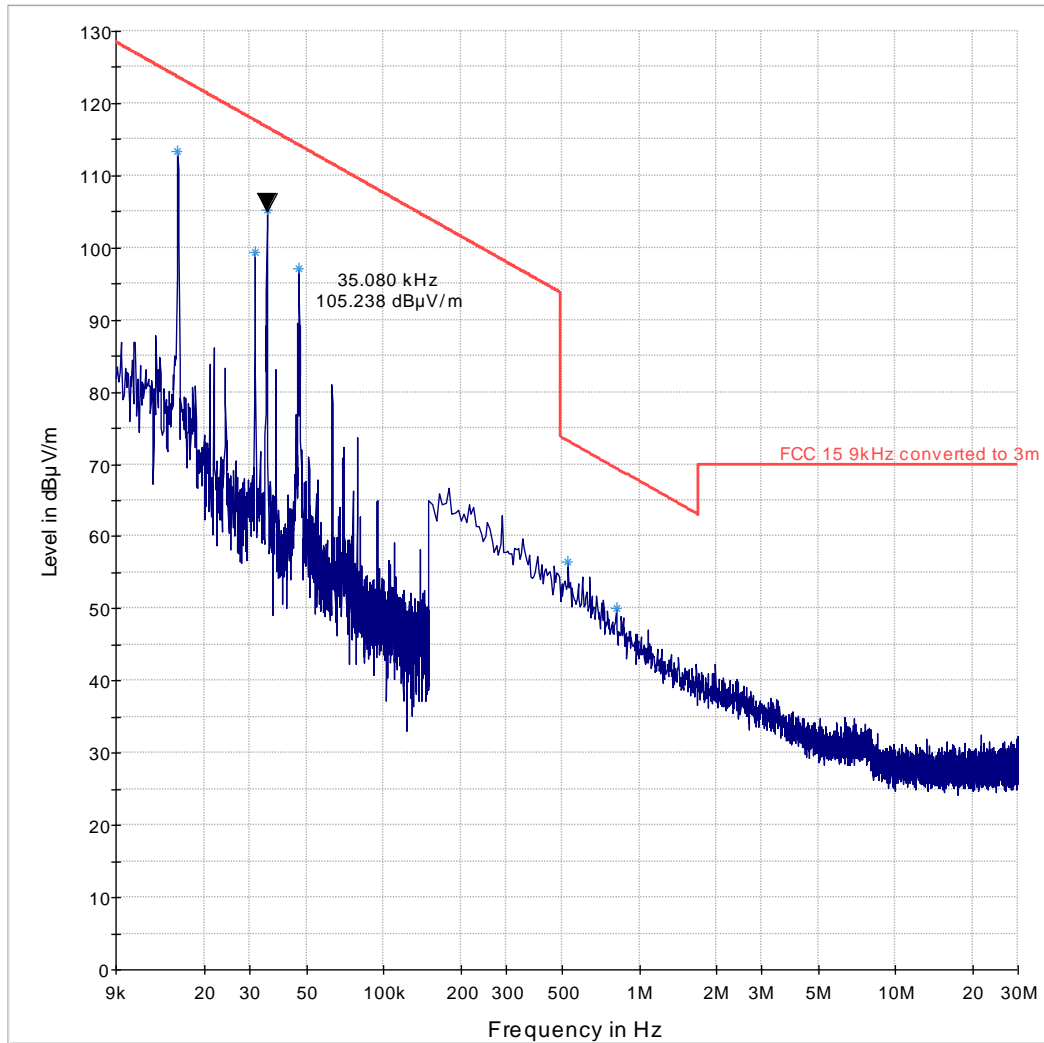

— FCC 15 9kHz converted to 3m — Preview Result 1-PK+ \* Data Reduction Result 1 [1]-PK+

**Transmitter Radiated Spurious Emission: Ch Low- 30 MHz – 1GHz- 802.11b-mode**

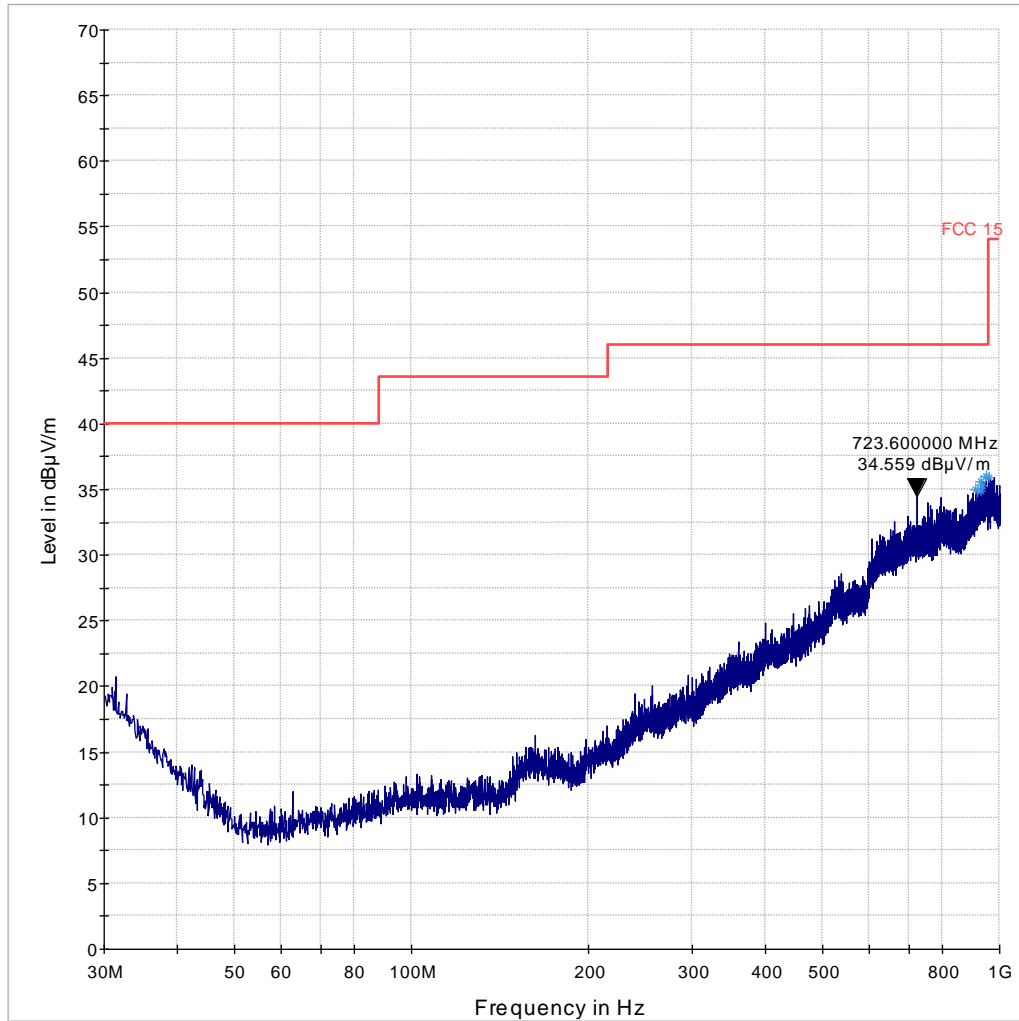

— FCC 15    — Preview Result 1-PK+    \* Data Reduction Result 1 [2]-PK+

**Transmitter Radiated Spurious Emission: Ch Mid- 30 MHz – 1GHz- 802.11b-mode**

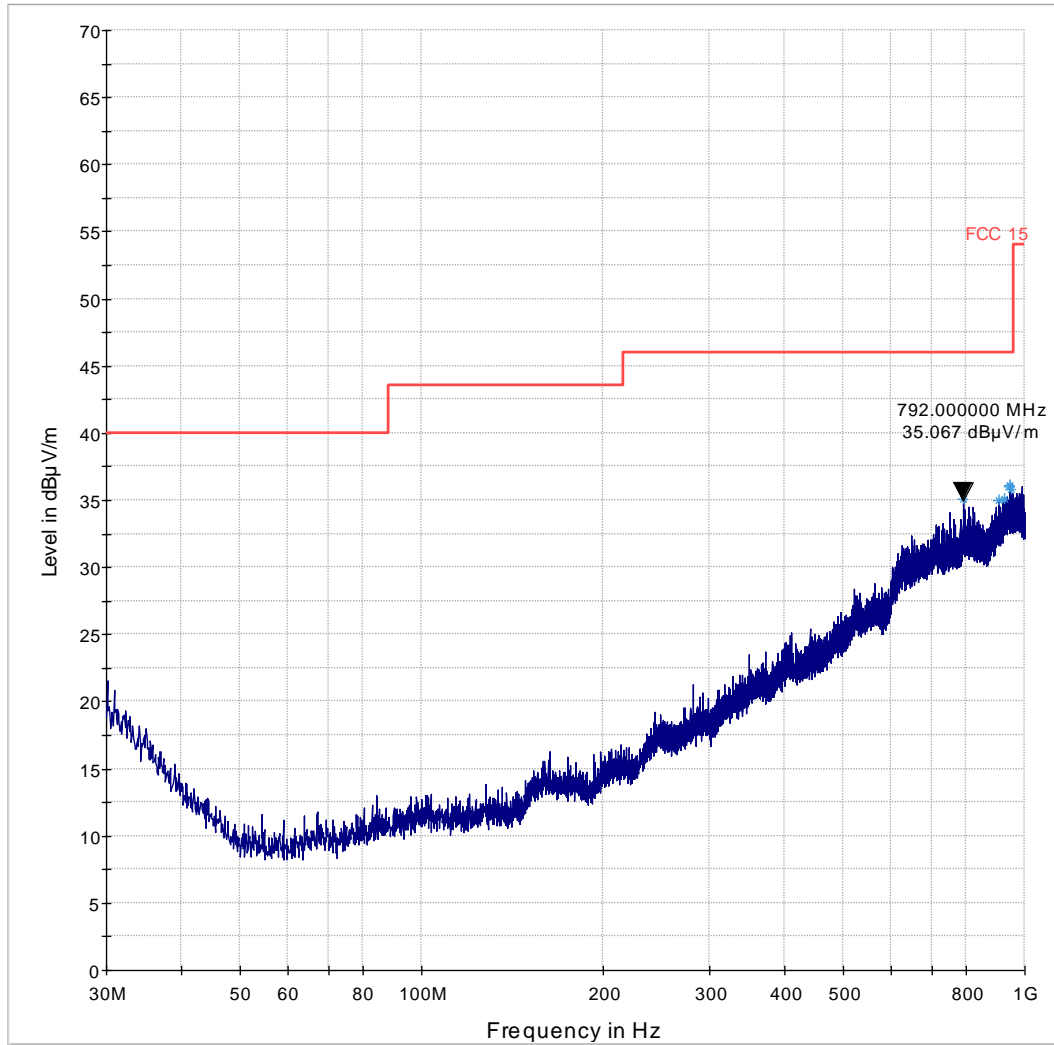

— FCC 15    — Preview Result 1-PK+    \* Data Reduction Result 1 [2]-PK+



**Transmitter Radiated Spurious Emission: Ch High- 30 MHz – 1GHz- 802.11b-mode**

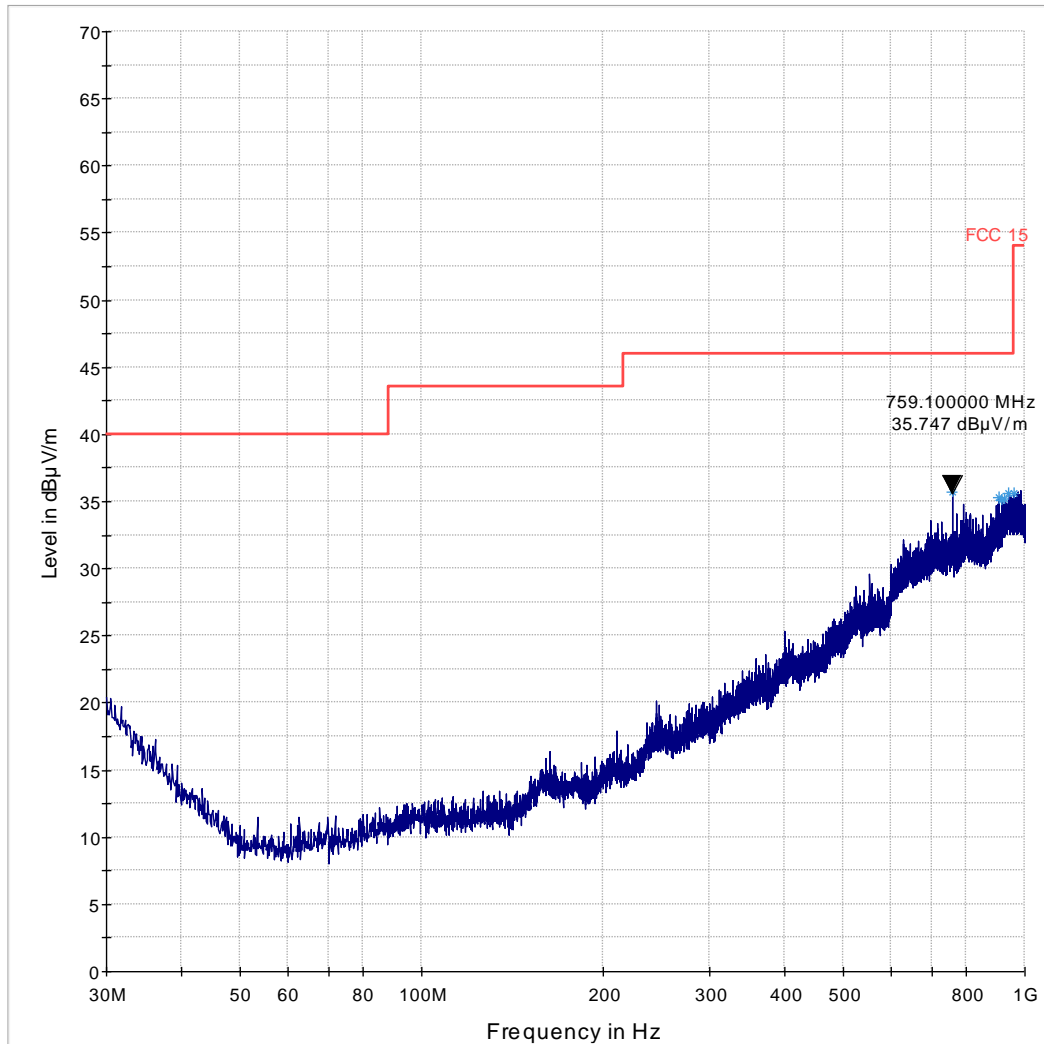

— FCC 15    — Preview Result 1-PK+    \* Data Reduction Result 1 [2]-PK+

**Transmitter Radiated Spurious Emission: Ch Low- 1GHz – 3GHz- 802.11b-mode**

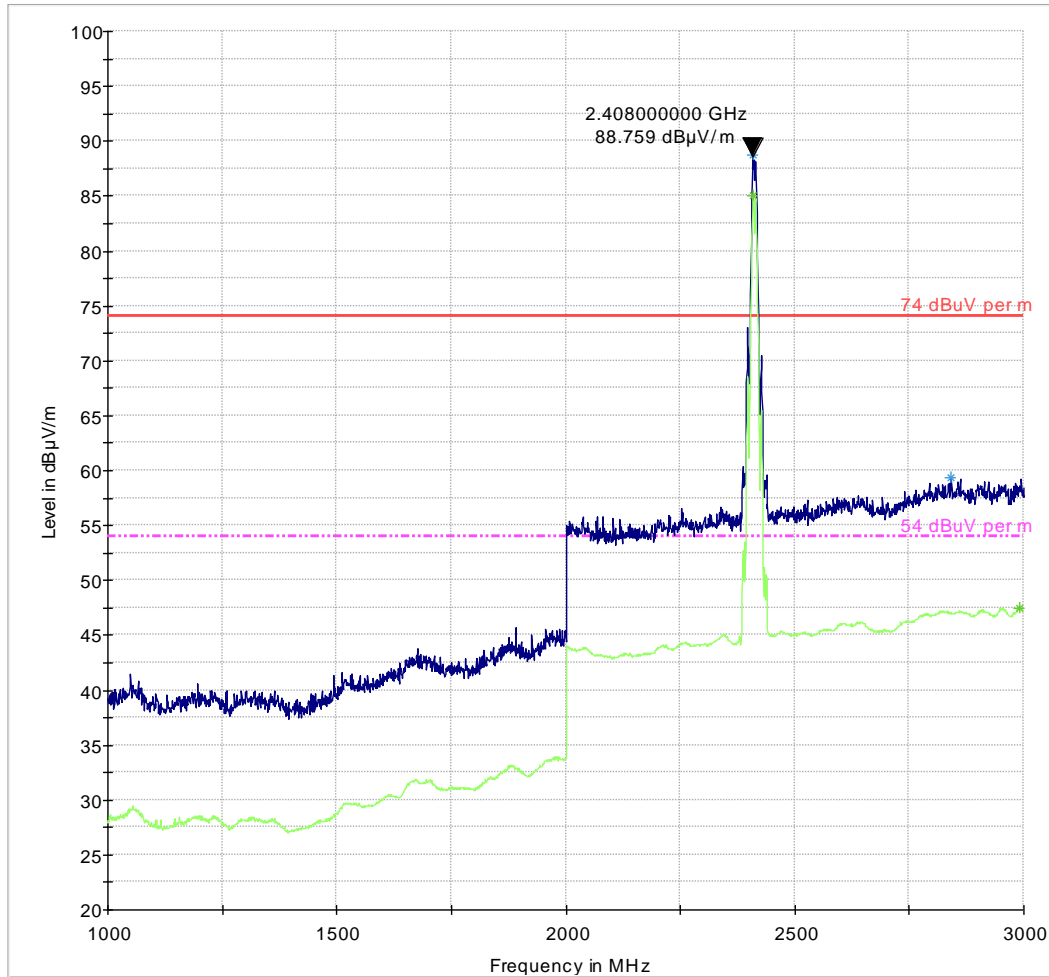

- 74 dBuV per m
- 54 dBuV per m
- Preview Result 1-PK+
- Preview Result 2-RMS
- Data Reduction Result 1 [4]-PK+
- Data Reduction Result 2 [4]-RMS

Note: Emission above the limit line is the transmit signal.

**Transmitter Radiated Spurious Emission: Ch Mid- 1GHz – 3GHz- 802.11b-mode**

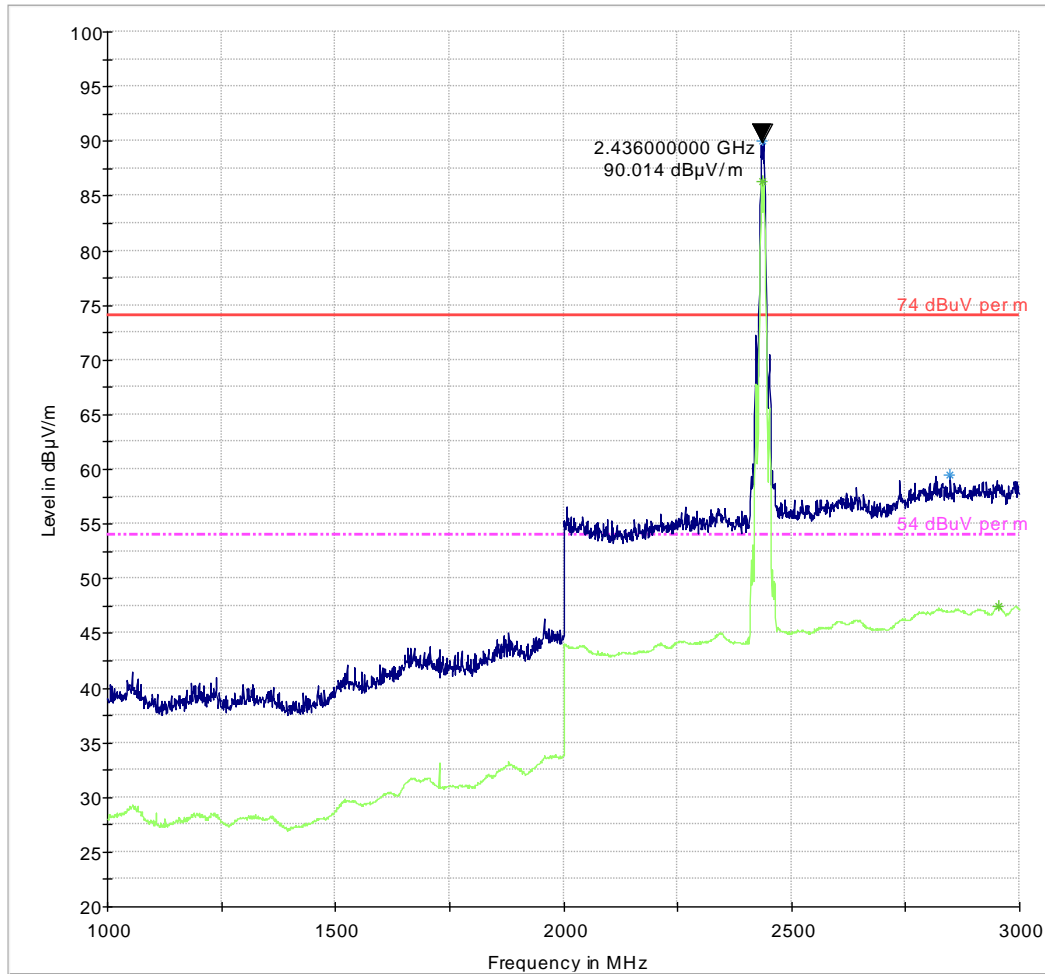

- 74 dBuV per m
- 54 dBuV per m
- Preview Result 1-PK+
- Preview Result 2-RMS
- \* Data Reduction Result 1 [4]-PK+
- \* Data Reduction Result 2 [4]-RMS

Note: Emission above the limit line is the transmit signal.

**Transmitter Radiated Spurious Emission: Ch High- 1GHz – 3GHz- 802.11b-mode**

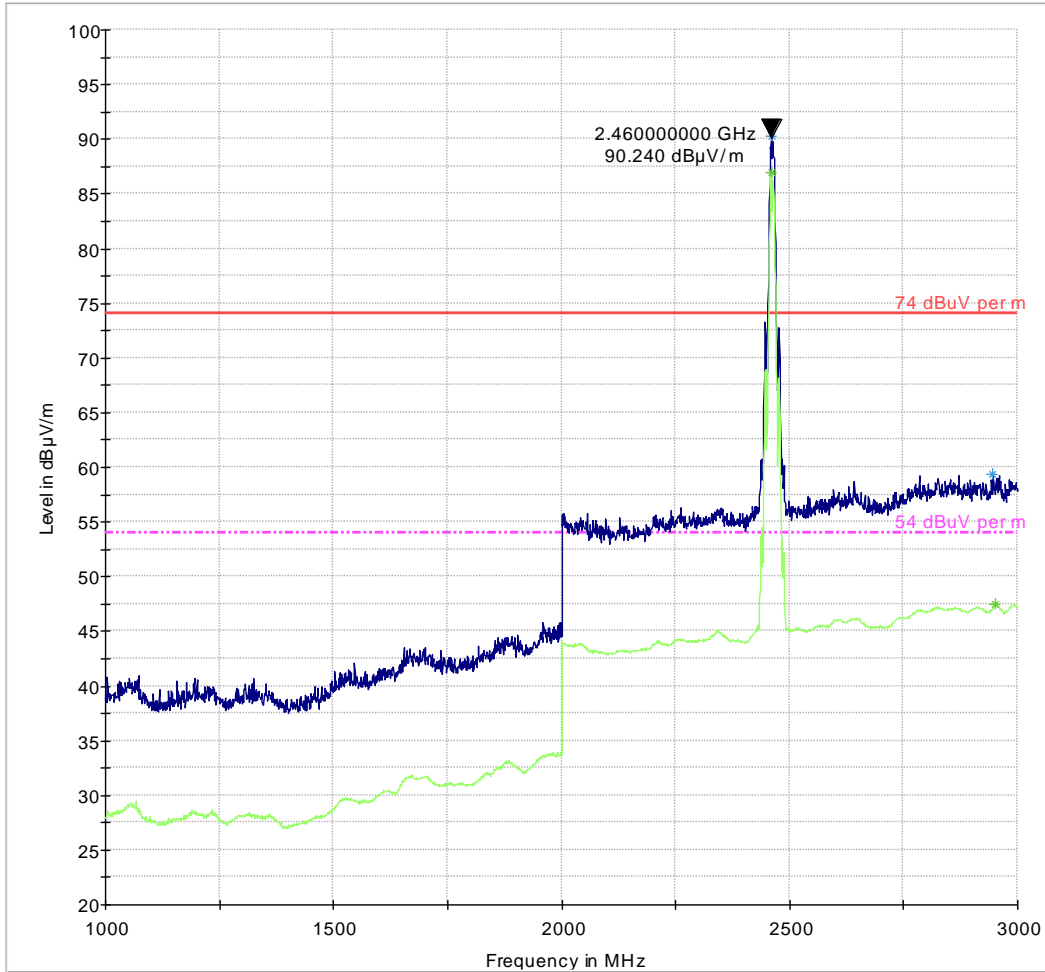

- 74 dBuV per m
- 54 dBuV per m
- \* Preview Result 1-PK+
- \* Preview Result 2-RMS
- \* Data Reduction Result 1 [4]-PK+
- \* Data Reduction Result 2 [4]-RMS

Note: Emission above the limit line is the transmit signal.

**Transmitter Radiated Spurious Emission: Ch Low- 3 GHz – 18 GHz- 802.11b-mode**

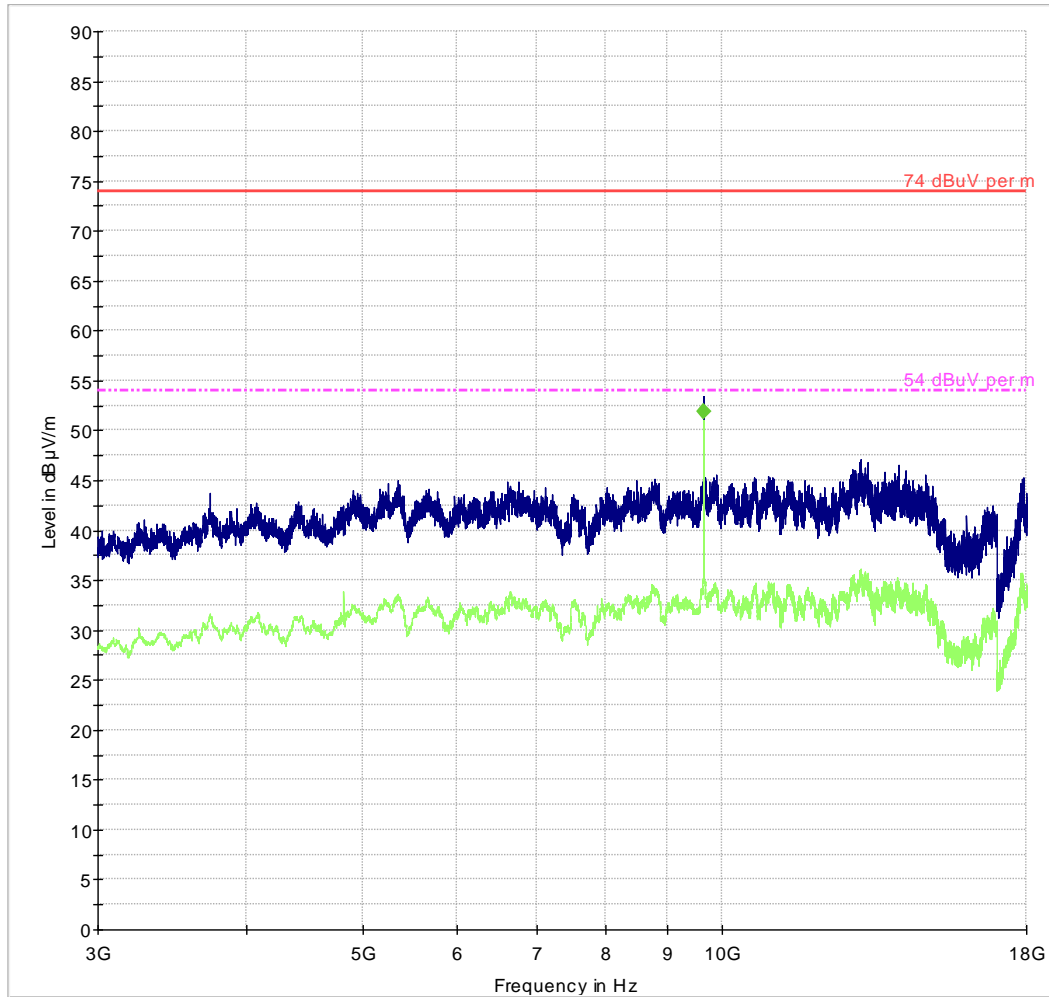

— 74 dBuV per m      - - - 54 dBuV per m      — Preview Result 1-PK+  
— Preview Result 2-RMS      ◆ Final Result 2-AVG

**Transmitter Radiated Spurious Emission: Ch Mid- 3 GHz – 18 GHz- 802.11b-mode**

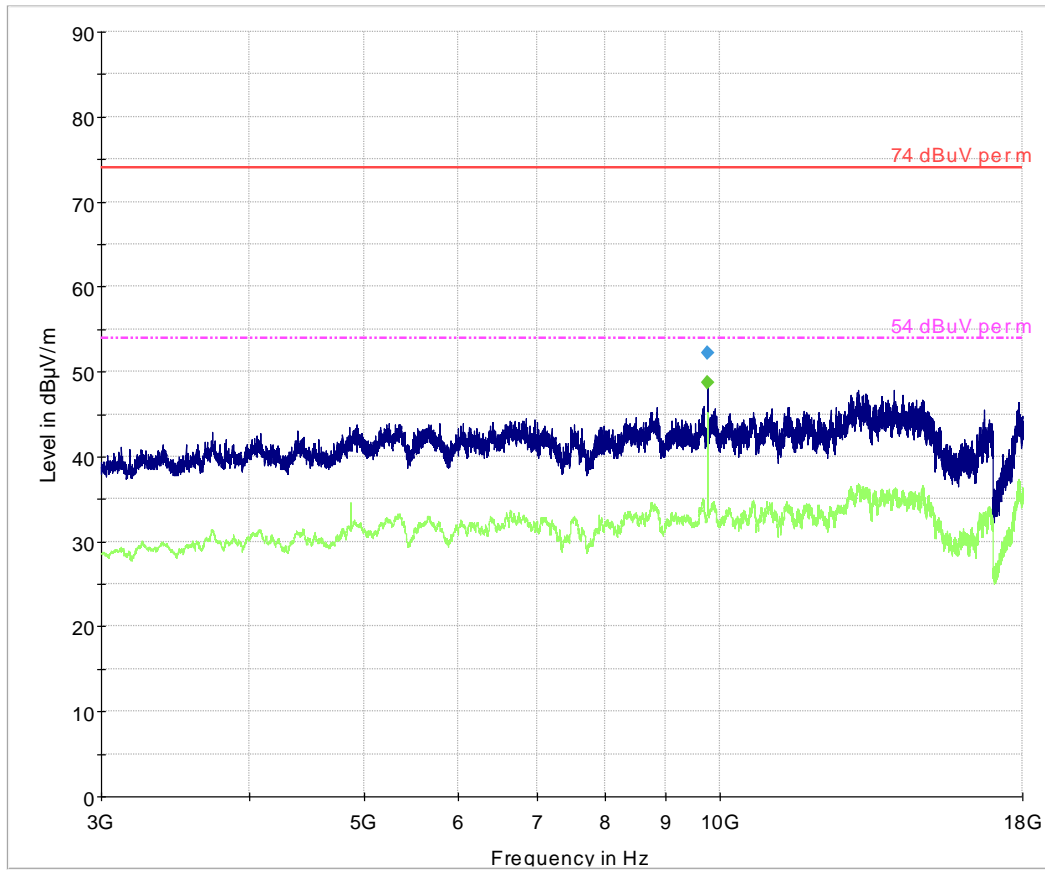

— 74 dBuV per m      - - - - 54 dBuV per m      — Preview Result 1-PK+  
— Preview Result 2-RMS      ◆ Final Result 1-PK+      ◆ Final Result 2-AVG

**Transmitter Radiated Spurious Emission: Ch High- 3 GHz – 18 GHz- 802.11b-mode**

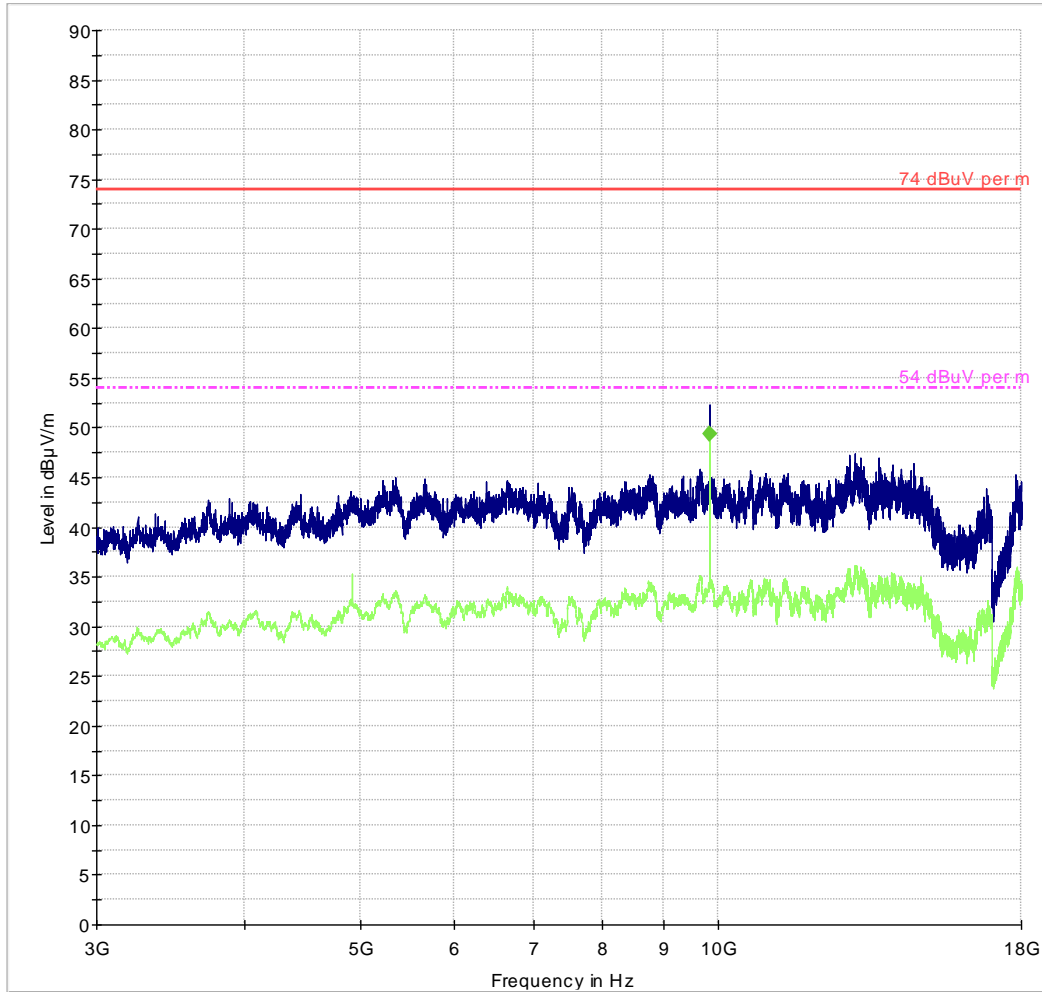

— 74 dBuV per m      - - - - 54 dBuV per m      — Preview Result 1-PK+  
— Preview Result 2-RMS      ◆ Final Result 2-AVG

**Transmitter Radiated Spurious Emission: Ch Mid 18GHz- 26 GHz - 802.11b-mode**

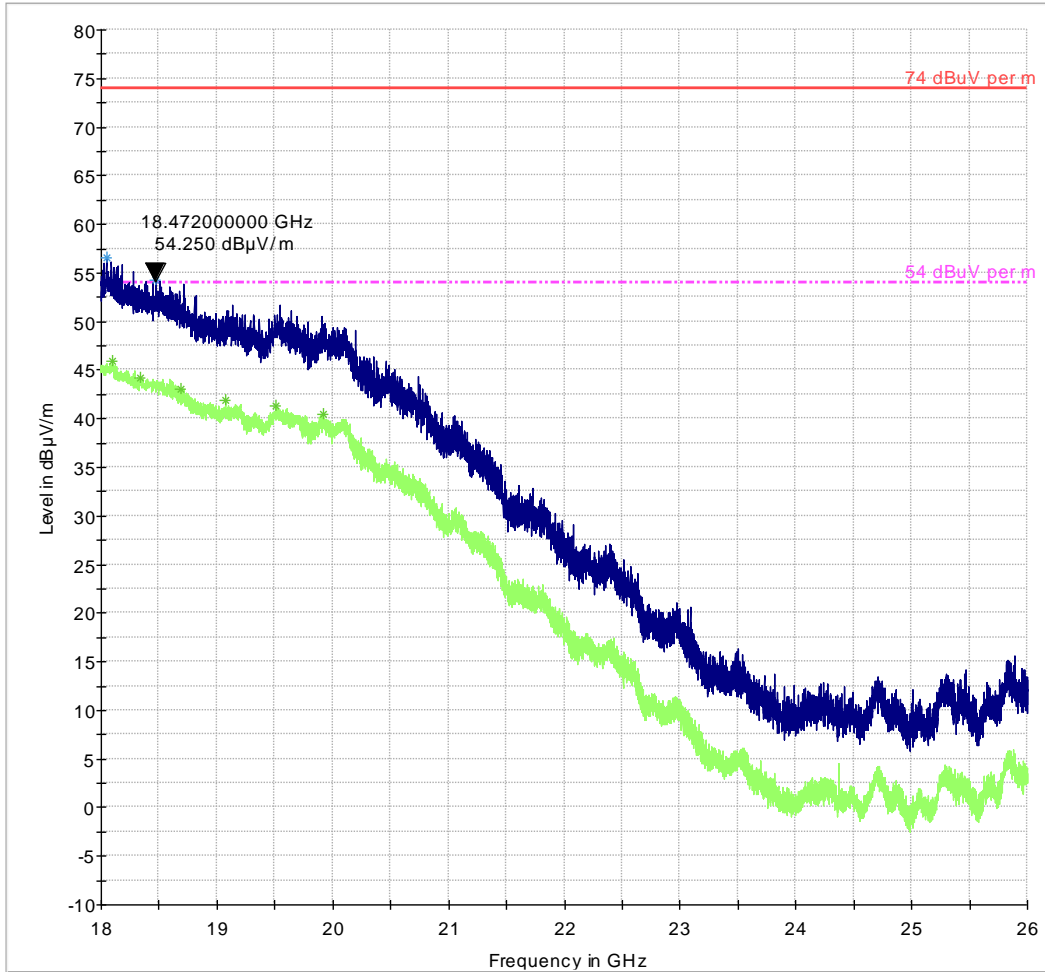

- 74 dBuV per m
- Preview Result 1-PK+
- \* Data Reduction Result 1 [6]-PK+
- - - 54 dBuV per m
- Preview Result 2-RMS
- \* Data Reduction Result 2 [6]-RMS



**Transmitter Radiated Spurious Emission: Ch Mid- 9kHz – 30MHz- 802.11g-mode**

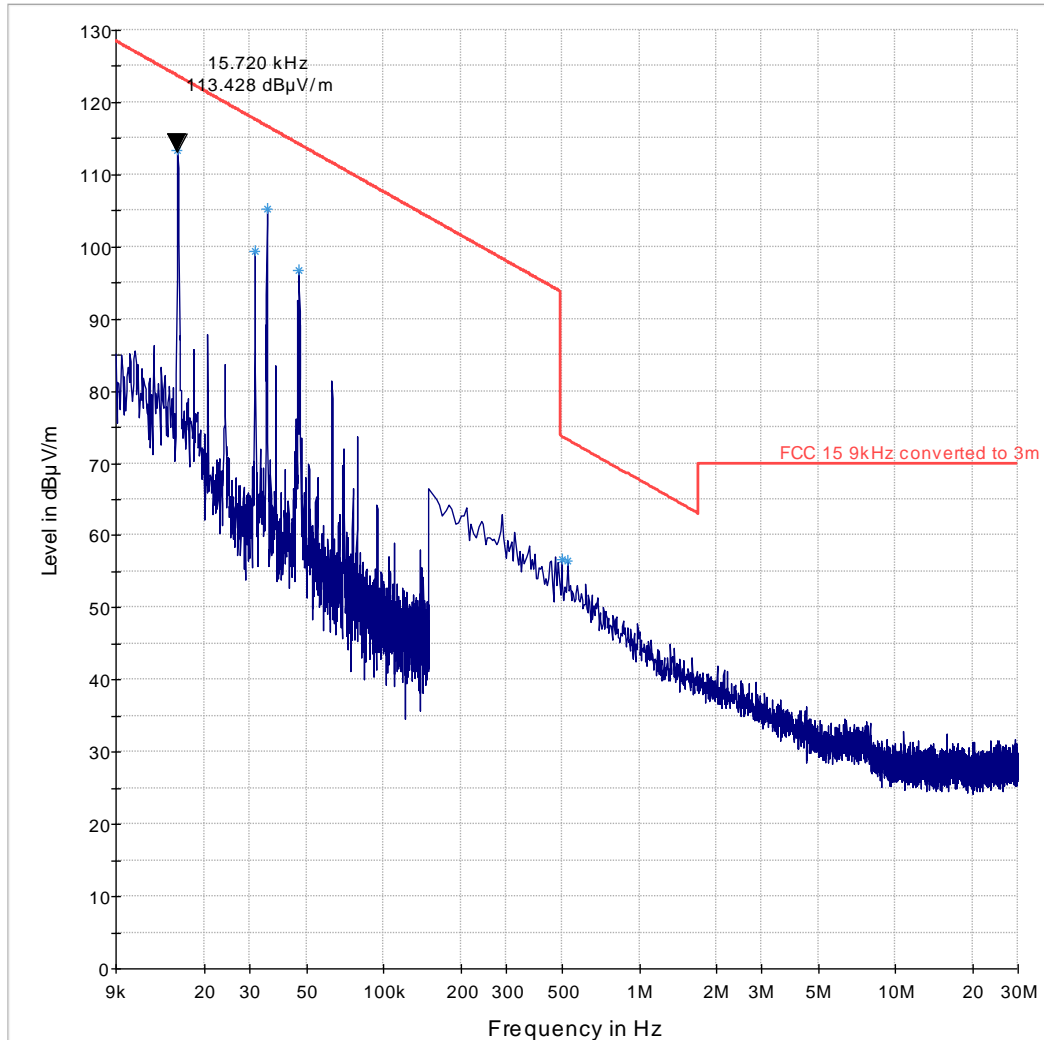

— FCC 15 9kHz converted to 3m — Preview Result 1-PK+ \* Data Reduction Result 1 [1]-PK+

**Transmitter Radiated Spurious Emission: Ch Mid- 30 MHz – 1GHz- 802.11g-mode**

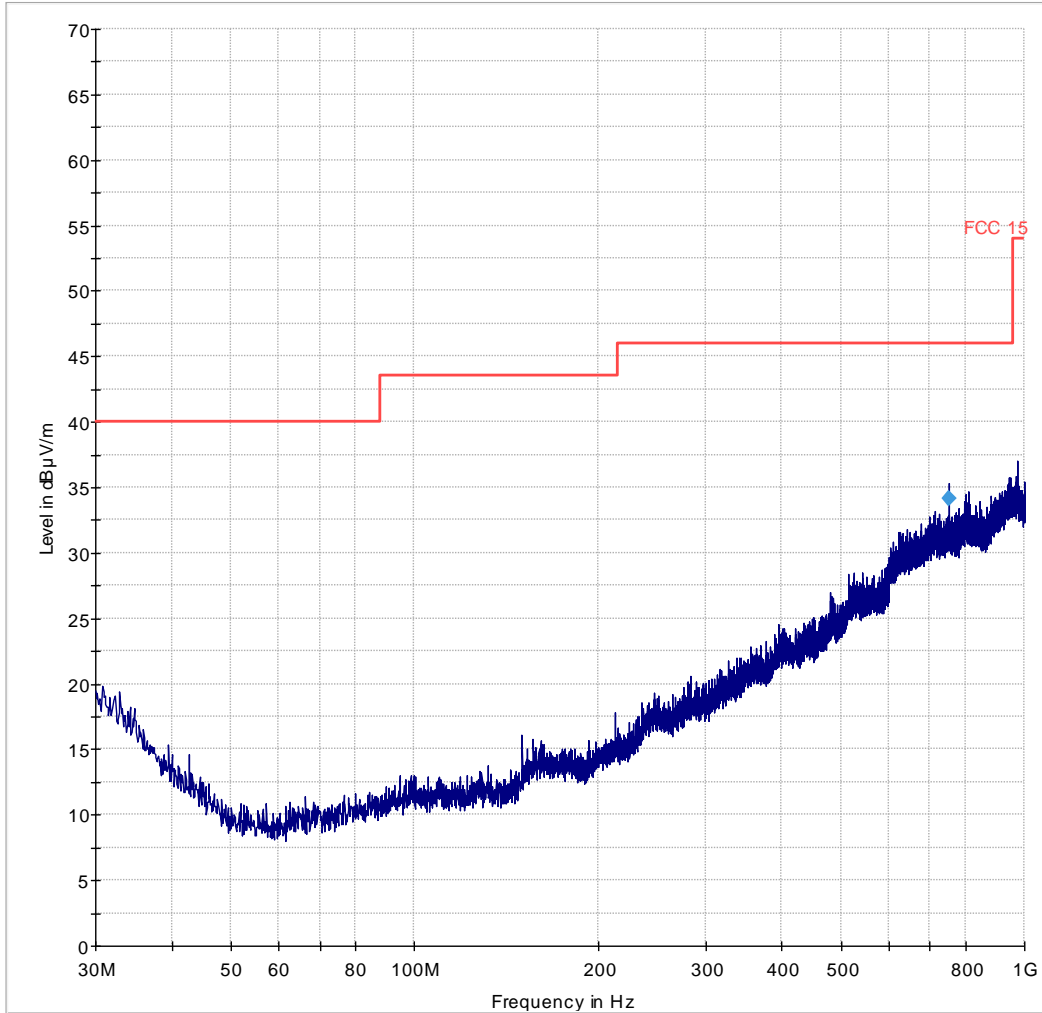

— FCC 15    — Preview Result 1-PK+    ◆ Final Result 1-QPK

**Transmitter Radiated Spurious Emission: Ch Mid- 1GHz – 3GHz- 802.11g-mode**

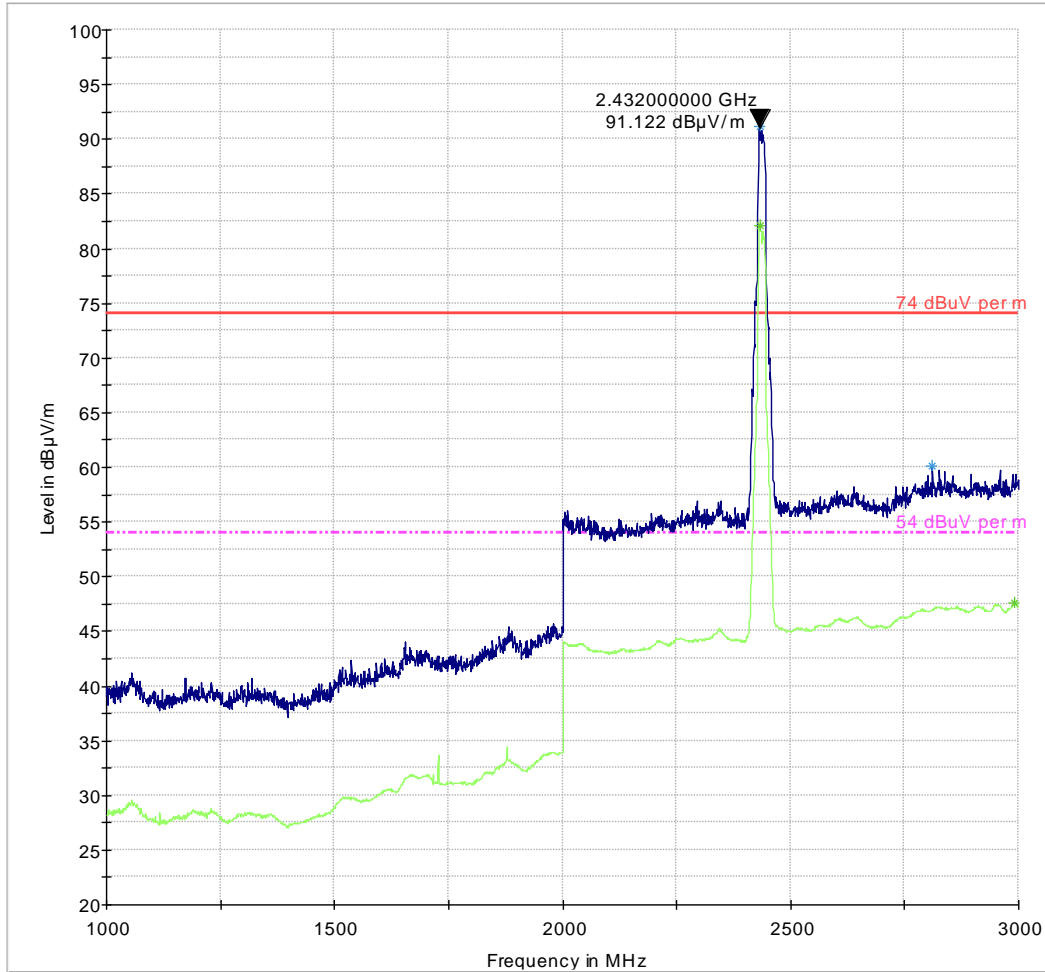

- 74 dBuV per m
- 54 dBuV per m
- Preview Result 1-PK+
- Preview Result 2-RMS
- \* Data Reduction Result 1 [4]-PK+
- \* Data Reduction Result 2 [4]-RMS

Note: Emission above the limit line is the transmit signal.

**Transmitter Radiated Spurious Emission: Ch Mid- 3 GHz – 18 GHz- 802.11n-mode**

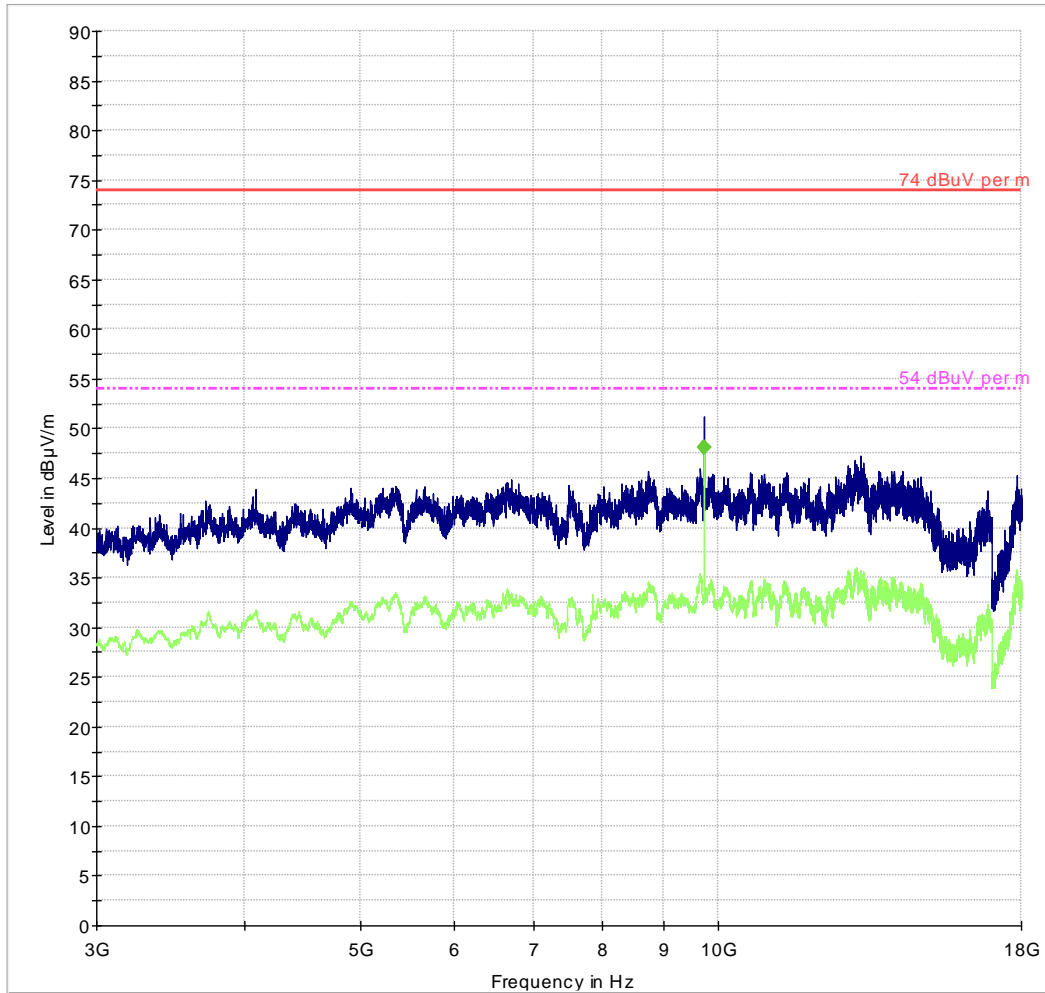

— 74 dBuV per m      - - - - 54 dBuV per m      — Preview Result 1-PK+  
— Preview Result 2-RMS      ◆ Final Result 2-AVG

**Transmitter Radiated Spurious Emission: Ch Mid 18GHz- 26 GHz**

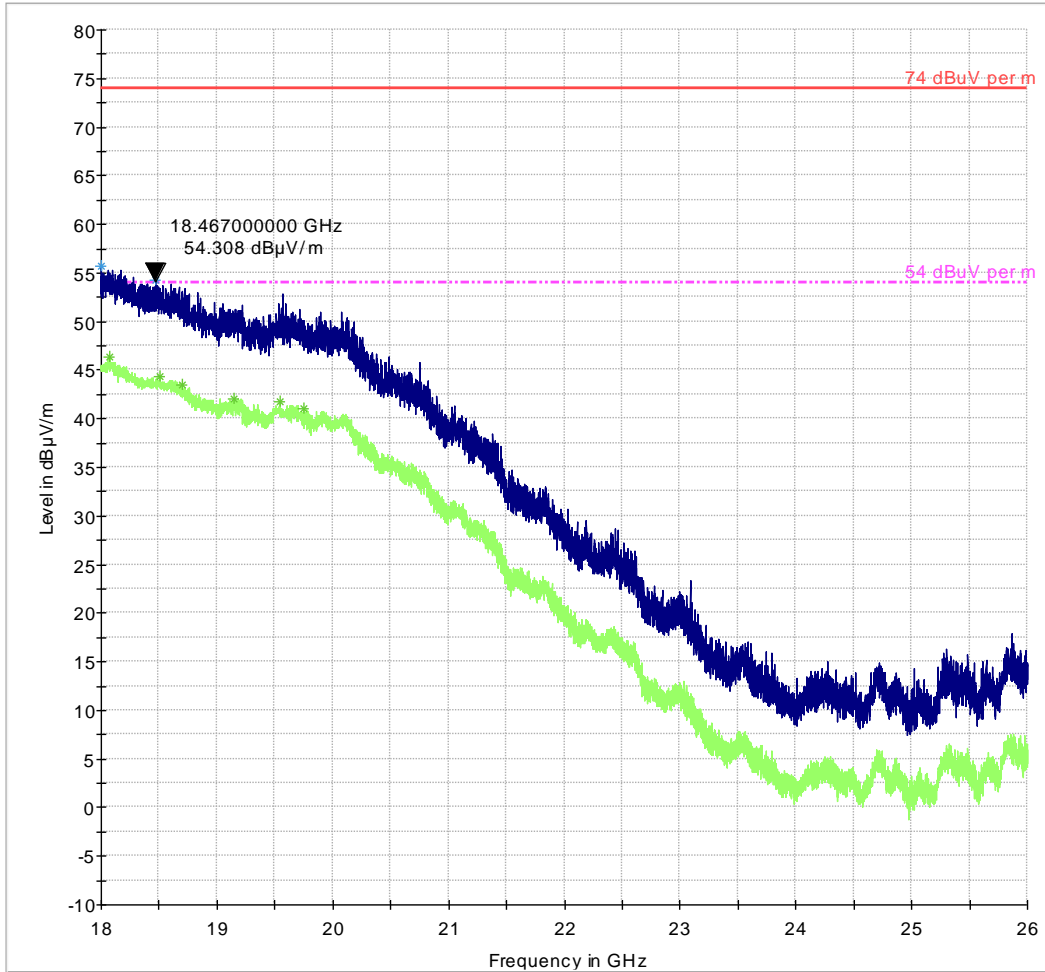

- 74 dBµV per m
- Preview Result 1-PK+
- \* Data Reduction Result 1 [6]-PK+
- - - 54 dBµV per m
- Preview Result 2-RMS
- \* Data Reduction Result 2 [6]-RMS

## 8.7 AC Power Line Conducted Emissions

### 8.7.1 Measurement Procedure.

Measurements in according to ANSI C63.10 (2013)

#### Spectrum Analyzer Settings:

- RBW = 9 KHz (CISPR Bandwidth)
- Detector: Peak / Average for Pre-scan
- Quasi-Peak/Average for Final Measurements

### 8.7.2 Limits:

FCC §15.207(a) & RSS-Gen 8.8

- Except as shown in paragraphs (b) and (c) of this section of the CFR, for an intentional radiator that is designed to be connected to the public utility (AC) power line, the radio frequency voltage that is conducted back onto the AC power line on any frequency or frequencies, within the band 150 kHz to 30 MHz, shall not exceed the limits in the following table (1), as measured using a 50 μH/50 ohms line impedance stabilization network (LISN). Compliance with the provisions of this paragraph shall be based on the measurement of the radio frequency voltage between each power line and ground at the power terminal. The lower limit applies at the boundary between frequency ranges.

Frequency of emission (MHz)	Conducted limit (dBμV)	
	Quasi-peak	Average
0.15–0.5	66 to 56*	56 to 46*
0.5–5	56	46
5–30	60	50

\*Decreases with the logarithm of the frequency.

### 8.7.3 Test conditions and setup:

Ambient Temperature (C)	EUT Set-Up #	EUT operating mode	Power line (L1, N)	Power Input
22.5	1	802.11b	Line & Neutral	110V / 60Hz

### 8.7.4 Measurement Result:

Plot #	Port	EUT Set-Up #	EUT operating mode	Scan Frequency	Limit	Result
1	AC Mains	1	BPSK	150 kHz – 30 MHz	See section 8.3.2	Pass

### 8.7.5 Measurement Plots:

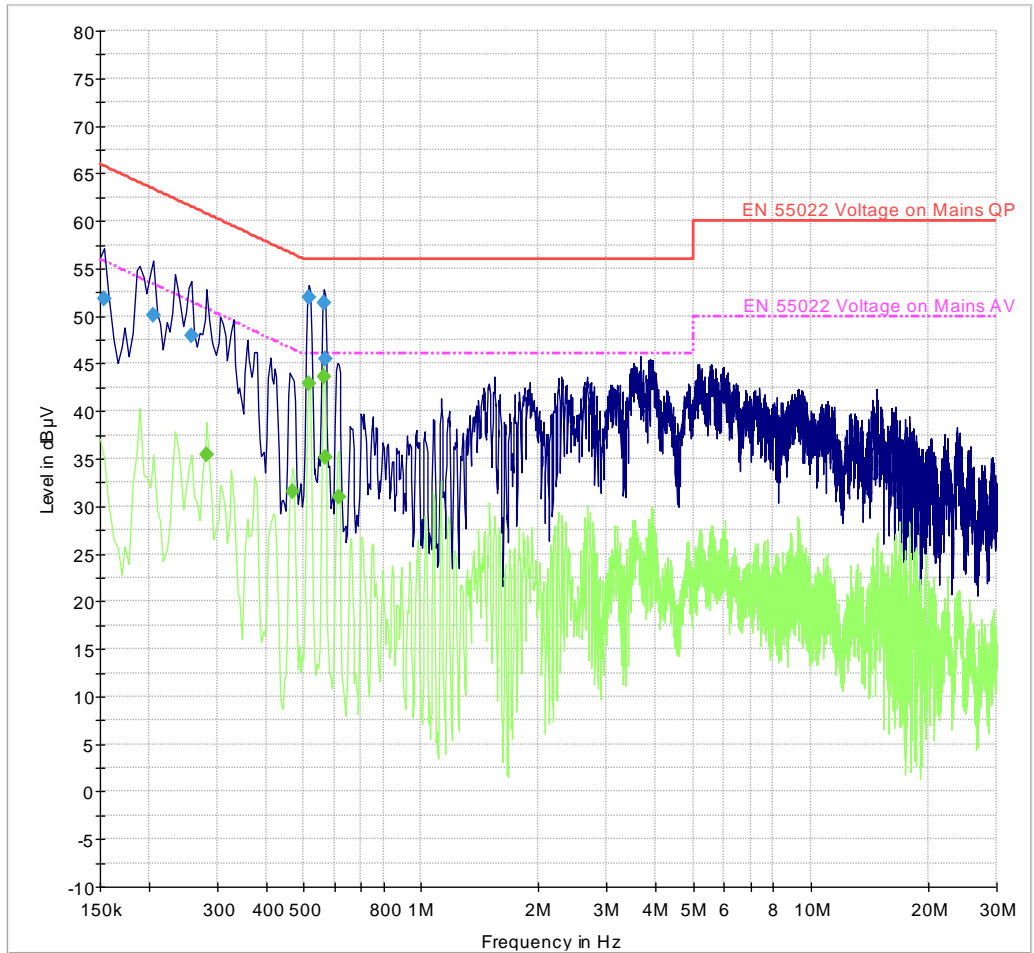

- EN 55022 Voltage on Mains QP
- EN 55022 Voltage on Mains AV
- ◆ Final Result 1-QPK
- ◆ Final Result 2-AVG
- Preview Result 1-PK+
- Preview Result 2-AVG

### Final Result 1

Frequency (MHz)	QuasiPeak (dBµV)	Meas. Time (ms)	Bandwidth (kHz)	PE	Line	Corr. (dB)	Margin (dB)	Limit (dBµV)	Comment
0.154000	51.8	500.0	9.000	GND	L1	8.5	13.9	65.8	
0.206000	50.1	500.0	9.000	GND	L1	6.8	13.2	63.4	
0.258000	48.0	500.0	9.000	GND	L1	5.2	13.5	61.5	
0.514000	51.9	500.0	9.000	GND	L1	2.0	4.1	56.0	
0.562000	51.3	500.0	9.000	GND	L1	1.8	4.7	56.0	
0.566000	45.5	500.0	9.000	GND	L1	1.8	10.5	56.0	

### Final Result 2

Frequency (MHz)	Average (dBµV)	Meas. Time (ms)	Bandwidth (kHz)	PE	Line	Corr. (dB)	Margin (dB)	Limit (dBµV)	Comment
0.282000	35.4	500.0	9.000	GND	L1	4.5	15.4	50.8	
0.466000	31.6	500.0	9.000	GND	L1	2.2	15.0	46.6	
0.514000	42.9	500.0	9.000	GND	L1	2.0	3.1	46.0	
0.562000	43.6	500.0	9.000	GND	L1	1.8	2.4	46.0	
0.566000	35.1	500.0	9.000	GND	L1	1.8	10.9	46.0	
0.614000	31.0	500.0	9.000	GND	L1	1.6	15.0	46.0	



Date of Report : Dec. 14, 2016

**9 EUT Setup Pictures**

Please refer to EMC-WHIST-003-16001-TestSetupPhotos.pdf

**10 Test Equipment and Ancillaries used for tests**

Item Name	Equipment Type	Manufacturer	Model	Serial #	Calibration Cycle	Last Calibration Date
Turn table	Turn table	EMCO	2075	N/A	N/A	N/A
MAPS Position Controller	Controller	ETS Lindgren	2092	0004-1510	N/A	N/A
Antenna Mast	Antenna Mast	EMCO	2075	N/A	N/A	N/A
High Pass Filter	Filter	5HC2700	Trilithic Inc.	9926013	Part of system calibration	
High Pass Filter	Filter	4HC1600	Trilithic Inc.	9922307	Part of system calibration	
6GHz High Pass Filter	Filter	HPM50106	Microtronics	001	Part of system calibration	
Pre-Amplifier	Amplifier	JS4-00102600	Miteq	00616	Part of system calibration	
Relay Switch Unit	Relay Switch Unit	Rohde&Schwarz	RSU	338964/001	N/A	N/A
Spectrum Analyzer FSU26 #2	Spectrum Analyzer	R&S	FSU26	200065	3 years	7/4/2015
Antenna Biconilog 3142E	Biconlog Antenna	EMCO	3142E	166067	3 years	6/14/2014
Antenna Loop 6512	Loop Antenna	ETS Lindgren	6512	49838	3 years	3/13/2014
Antenna Horn 3115 SN 35111	Horn Antenna	EMCO	3115	35111	3 years	7/24/2015
Antenna Horn 3116	Horn Antenna	ETS Lindgren	3116	70497	3 years	7/22/2015
LISN FCC-LISN-50-25-2-08	LISN	FCC	FCC-LISN-50-25-2-08	8014	2 Years	3/26/2015
Digital Barometer	Compact Digital Barometer	Control Company	35519-055	91119547	2 Years	4/7/2015
ESU 40	Receiver	R&S	ESU 40	100251	2 years	6/29/2015
Thermometer Humidity TM320	Thermometer Humidity	Dickson	AY1072	0528	1 Year	11/02/2016

Test Report #: EMC-WHIST-003-16001-15-247-DTS-WLAN

FCC ID: S8W-W03A

IC ID: 10959A-W03A 

Date of Report : Dec. 14, 2016

---

11 **Revision History**

Date	Report Name	Changes to report	Prepared by
Dec. 14, 2016	EMC-WHIST-003-16001-15-247-DTS-WLAN	Initial version	James Donnellan