

Advanced
Compliance Laboratory

6 Randolph Way
Hillsborough, NJ 08844
Tel: (908) 927 9288
Fax: (908) 927 0728

**Electromagnetic
Emission
Compliance
Test Report**



Equipment Under Test (EUT) Applicant Remote Radio Head 2x45W 1900MHz AA190045 RF151032 Andrew Corporation

In Accordance With FCC Part 2 and Part 24, Subpart E

Test by Advanced Compliance Laboratory, Inc.
6 Randolph Way
Hillsborough, New Jersey 08844

Authorized by Wei Li
Lab Manager

Signature

Date June 28, 2013

AC Lab Report Number 0048-130617-01



Lab Code:200101-0

The test result in this report is supported and covered by the NVLAP accreditation.

Index

Section 1. Summary of Test Results	3
Section 2. General Equipment Specification	5
Section 3. RF Output Power	8
Section 4. Occupied Bandwidth	20
Section 5. Spurious Emissions at Antenna Terminals	76
Section 6. Field Strength of Spurious	149
Section 7. Frequency Stability	154
Section 8. Test Equipment List	156
Section 9. FCC ID Labeling	157
Section 10. Maximum Permissible Exposure	158
Section 11. Setup Photos	159
Section 12. EUT Photos	161

Section 1. Summary of Test Results

Manufacturer: Andrew Corporation
Product Name: RRH 2x45W 1900MHz AA190045
Parts No.: RF151032

General: **All measurements are traceable to national standards**

These tests were conducted on a sample of the equipment for the purpose of demonstrating compliance with Part 24, Subpart E.

New Submission Production Unit
 Class II Permissive Change Pre-Production Unit

THIS TEST REPORT RELATES ONLY TO THE ITEM(S) TESTED.

THE FOLLOWING DEVIATIONS FROM, ADDITIONS TO, OR EXCLUSIONS FROM THE TEST SPECIFICATIONS HAVE BEEN MADE.

“See Summary of Test Data”



NVLAP LAB CODE: 200101-0

Advance Compliance Laboratory, Inc. authorizes the above named company to reproduce this report provided it is reproduced in its entirety and for use by the company's employees only.

Any use which a third party makes of this report, or any reliance on or decisions to be made based on it, are the responsibility of such third parties. Advance Compliance Laboratory, Inc. accepts no responsibility for damages, if any, suffered by any third party as a result of decisions made or actions based on this report. This report applies only to the items tested.

Summary of Test Data

RF Power Output	24.232(a)	1640W EIRP	Complies**
Occupied Bandwidth (Digital)	2.1049(i)	---	Complies
Spurious Emissions at Antenna Terminals	24.238	-13 dBm	Complies
Field Strength of Spurious Emissions	24.238	-13 dBm E.I.R.P.	Complies
Frequency Stability	24.235	0.05 ppm	Complies

** See page 10.

The estimated uncertainty of the test result is given as following. The method of uncertainty calculation is provided in Advanced Compliance Lab. Doc. No. 0048-01-01.

	Prob. Dist.	Uncertainty(dB)	Uncertainty(dB)	Uncertainty(dB)
		30-1000MHz	1-6.5GHz	Conducted
Combined Std. Uncertainty u_c	norm.	± 2.36	± 2.99	± 1.83



Wei Li
Lab Manager
Advanced Compliance Lab

Date: June 28, 2013

Section 2. General Equipment Specification

Supply Voltage	-48VDC (extended -39.5VDC to -57VDC)				
Frequency Range	PCS Broad Band	TX/ 1930 – 1995 MHz			
		RX/ 1850 – 1915 MHz			
Modulation	<input checked="" type="checkbox"/> LTE OFDMA in FDD	WCDMA	GSM	EDGE	TDMA
Type of Emissions	F9W	F9W	GXW	G7W	DXW
Rated Power	45W (46.5dBm) average @ each Tx Port Total two Tx Ports presented with total combined output power: 90W (49.5dBm)				
Operating Power	45W average / Single Carrier 22.5W/ Carrier (2 Carriers)				
Channel BW /Output Impedance	5MHz, 10MHz, 20MHz 50ohm				
Frequency Translation	F1-F1 <input type="checkbox"/>	F1-F2 <input type="checkbox"/>	N/A <input checked="" type="checkbox"/>		
	Software <input checked="" type="checkbox"/>	Duplexer Change <input type="checkbox"/>	Full Band Coverage <input type="checkbox"/>		

DC voltages and DC currents per 2.1033(c)(8)

The input supply to the Remote Radio Head (RRH) was set at -48 Volts DC. The RF power output was measured with the indicated voltage and current applied into the RRH.

RRH 2x45W 1900MHz AA190045

RF Output, DC Current and RF Input Power are all average values.

Active Mode:

Measured Rated RF output @ each Tx port: 46.5dBm (45W)

Measured DC voltage: -48.0V

Measured DC current: 8.05A.

Standby Mode:

Measured Minimum RF output: -16.0dBm (0.025mW)

Measured DC voltage: -48.0V

Measured DC current: 1.05A

Tune-up procedure per 2.1033(c) (9)

There are no user accessible adjustments or tuning in this EUT. All necessary adjustments and tuning are performed during manufacture of the product. Any adjustments or tuning after service or repair are done as part of that process as special equipment is required to perform such adjustments.

Description of Operation

The EUT operated in FCC 1900MHz band, has two identical sections, each has one RF transmitter & two receivers, a double duplex filter and a dual simplex filter.

All measurements shall be made at room temperature and at nominal DC input voltage unless noted otherwise. All measurements were performed with the EUT configured for maximum transmit power.

System Diagram

See Attachment.

General EUT Setup

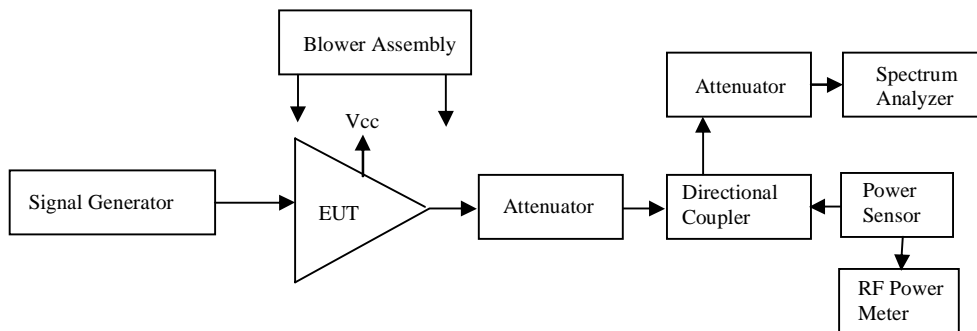

TX Waveforms & Operation Frequency Channels for testing:

Waveforms: TM11 (QPSK), TM32 (16QAM) and TM31 (64QAM)

Carrier Configurations	Frequency	Carrier BW	IBW	Carrier 1 Center Frequency	Carrier 2 Center Frequency	Confirmed
1C	Low	5MHz	5MHz	1932.5MHz	N/A	Y
1C	Middle	5MHz	5MHz	1962.5MHz	N/A	Y
1C	High	5MHz	5MHz	1992.5MHz	N/A	Y
1C	Low	10MHz	10MHz	1935MHz	N/A	Y
1C	Middle	10MHz	10MHz	1962.5MHz	N/A	Y
1C	High	10MHz	10MHz	1990MHz	N/A	Y
1C	Low	15MHz	15MHz	1937.5MHz	N/A	Y
1C	Middle	15MHz	15MHz	1962.5MHz	N/A	Y
1C	High	15MHz	15MHz	1987.5MHz	N/A	Y
1C	Low	20MHz	20MHz	1940MHz	N/A	Y
1C	Middle	20MHz	20MHz	1962.5MHz	N/A	Y
1C	High	20MHz	20MHz	1985MHz	N/A	Y
2C	Low	5MHz	40MHz	1932.5MHz	1967.5MHz	Y
2C	High	5MHz	40MHz	1957.5MHz	1992.5MHz	Y
2C	Low	5MHz	40MHz	1932.5MHz	1937.5MHz	Y for lower band edge test
2C	High	5MHz	40MHz	1987.5MHz	1992.5MHz	Y for higher band edge test
2C	Low	10MHz	40MHz	1935MHz	1965MHz	Y
2C	High	10MHz	40MHz	1960MHz	1990MHz	Y
2C	High	10MHz	40MHz	1935MHz	1945MHz	Y for lower band edge test
2C	High	10MHz	40MHz	1980MHz	1990MHz	Y for higher band edge test

Section 3. RF Output Power

Name of Test:	<i>RF Output Power</i>	Test Standard:	<i>24.232(a)</i>
Tested By:	WEI LI	Test Date:	06/17/2013-06/25/2013

Minimum Standard: Para. No. 24.232(a). The maximum peak output power of base transmitters should not exceed 1640W/MHz EIRP (62.1dBm/MHz).

Para No. 24.232(d). In measuring transmissions in this band using an average power technique, the peak-to-average ratio (PAR) of the transmission may not exceed 13 dB.

Method of Measurement: The manufacturer will provide an external antenna with maximum gain 17.5dBi for this product; hence system EIRP can be calculated per FCC KDB 971168 D01 Power Measurement License Digital Systems v02r01, i.e.

$EIRP \text{ (dBm/MHz)} = \text{RF Output Power at antenna port} + 17.5$

For devices utilizing multiple antennas, KDB 662911 provides guidance for determining the effective array transmit antenna gain term to be used in the above equation.

Per 2.1046: The RF Power Output level measured at each antenna port shall be +46.5 dBm (45 watts) +1 dB, -3 dB over the PCS frequency band: 1930-1995 MHz. The tolerance range is per TIA/EIA-97-D, Section 4.3.1.3.

Using power meter, average power measurements shall be taken at the low band edge, mid, and high band edge frequencies for all modulations listed on Page 7.

Per FCC KDB 971168 Sec. 5.7, Peak-to-Average Power Ratio (PAR) shall be measured to meet the <13dB limit.

Test Result:

Complies

Test Data:

Following tables

Rated Output Power – Normal Condition

The inputs are set to generate rated average output power and crest factor for the multi-carrier signals intended.

TX1/RX1 Port TM 11 Waveform (QPSK)

PCS Band	Channel	Modulation	Power Output (dBm)	Rated Power (dBm)	Deviation
Downlink	Low	5MHz LTE 1C	46.27	46.5	-0.23
	Mid	5MHz LTE 1C	46.59	46.5	0.09
	High	5MHz LTE 1C	46.44	46.5	-0.06
	Low	10MHz LTE 1C	46.46	46.5	-0.04
	Mid	10MHz LTE 1C	46.66	46.5	0.16
	High	10MHz LTE 1C	46.59	46.5	0.09
	Low	20MHz LTE 1C	46.69	46.5	0.19
	Mid	20MHz LTE 1C	46.83	46.5	0.33
	High	20MHz LTE 1C	46.83	46.5	0.33
	Low	5MHz LTE 2C	46.39	46.5	-0.11
	Mid	5MHz LTE 2C	46.54	46.5	0.04
	High	5MHz LTE 2C	46.52	46.5	0.02
	Low	10MHz LTE 2C	46.52	46.5	0.02
	Mid	10MHz LTE 2C	46.62	46.5	0.12
	High	10MHz LTE 2C	46.58	46.5	0.08
Ref Offset	Ref offset=Cable & Attenuator & Coupler Attenuation=50.7dB				

TX2/RX2 Port TM 11 Waveform

PCS Band	Channel	Modulation	Power Output (dBm)	Rated Power (dBm)	Deviation
Downlink	Low	5MHz LTE 1C	46.29	46.5	-0.21
	Mid	5MHz LTE 1C	46.6	46.5	0.1
	High	5MHz LTE 1C	46.34	46.5	-0.16
	Low	10MHz LTE 1C	46.45	46.5	-0.05
	Mid	10MHz LTE 1C	46.64	46.5	0.14
	High	10MHz LTE 1C	46.42	46.5	-0.08
	Low	20MHz LTE 1C	46.66	46.5	0.16
	Mid	20MHz LTE 1C	46.78	46.5	0.28
	High	20MHz LTE 1C	46.66	46.5	0.16
	Low	5MHz LTE 2C	46.36	46.5	-0.14
	Mid	5MHz LTE 2C	46.41	46.5	-0.09
	High	5MHz LTE 2C	46.36	46.5	-0.14
	Low	10MHz LTE 2C	46.42	46.5	-0.08
	Mid	10MHz LTE 2C	46.5	46.5	0
	High	10MHz LTE 2C	46.45	46.5	-0.05
Ref Offset	Ref offset=Cable & Attenuator & Coupler Attenuation=50.7dB				

TX1/RX1 Port TM31 Waveform (64 QAM)

PCS Band	Channel	Modulation	Power Output (dBm)	Rated Power (dBm)	Deviation
Downlink	Low	5MHz LTE 1C	46.22	46.5	-0.28
	Mid	5MHz LTE 1C	46.49	46.5	-0.01
	High	5MHz LTE 1C	46.34	46.5	-0.16
	Low	10MHz LTE 1C	46.34	46.5	-0.16
	Mid	10MHz LTE 1C	46.58	46.5	0.08
	High	10MHz LTE 1C	46.46	46.5	-0.04
	Low	20MHz LTE 1C	46.57	46.5	0.07
	Mid	20MHz LTE 1C	46.65	46.5	0.15
	High	20MHz LTE 1C	46.64	46.5	0.14
	Low	5MHz LTE 2C	46.27	46.5	-0.23
	Mid	5MHz LTE 2C	46.39	46.5	-0.11
	High	5MHz LTE 2C	46.36	46.5	-0.14
	Low	10MHz LTE 2C	46.34	46.5	-0.16
	Mid	10MHz LTE 2C	46.43	46.5	-0.07
	High	10MHz LTE 2C	46.44	46.5	-0.06
Ref Offset	Ref offset=Cable & Attenuator & Coupler Attenuation=50.7dB				

TX2/RX2 Port TM31 Waveform

PCS Band	Channel	Modulation	Power Output (dBm)	Rated Power (dBm)	Deviation
Downlink	Low	5MHz LTE 1C	46.17	46.5	-0.33
	Mid	5MHz LTE 1C	46.45	46.5	-0.05
	High	5MHz LTE 1C	46.18	46.5	-0.32
	Low	10MHz LTE 1C	46.3	46.5	-0.2
	Mid	10MHz LTE 1C	46.47	46.5	-0.03
	High	10MHz LTE 1C	46.31	46.5	-0.19
	Low	20MHz LTE 1C	46.52	46.5	0.02
	Mid	20MHz LTE 1C	46.65	46.5	0.15
	High	20MHz LTE 1C	46.49	46.5	-0.01
	Low	5MHz LTE 2C	46.22	46.5	-0.28
	Mid	5MHz LTE 2C	46.27	46.5	-0.23
	High	5MHz LTE 2C	46.24	46.5	-0.26
	Low	10MHz LTE 2C	46.31	46.5	-0.19
	Mid	10MHz LTE 2C	46.39	46.5	-0.11
	High	10MHz LTE 2C	46.32	46.5	-0.18
Ref Offset	Ref offset=Cable & Attenuator & Coupler Attenuation=50.7dB				

TX1/RX1 Port TM 32 Waveform (16 QAM)

PCS Band	Channel	Modulation	Power Output (dBm)	Rated Power (dBm)	Deviation
Downlink	Low	5MHz LTE 1C	46.22	46.5	-0.28
	Mid	5MHz LTE 1C	46.48	46.5	-0.02
	High	5MHz LTE 1C	46.35	46.5	-0.15
	Low	10MHz LTE 1C	46.33	46.5	-0.17
	Mid	10MHz LTE 1C	46.57	46.5	0.07
	High	10MHz LTE 1C	46.49	46.5	-0.01
	Low	20MHz LTE 1C	46.6	46.5	0.1
	Mid	20MHz LTE 1C	46.72	46.5	0.22
	High	20MHz LTE 1C	46.68	46.5	0.18
	Low	5MHz LTE 2C	46.31	46.5	-0.19
	Mid	5MHz LTE 2C	46.44	46.5	-0.06
	High	5MHz LTE 2C	46.39	46.5	-0.11
	Low	10MHz LTE 2C	46.43	46.5	-0.07
	Mid	10MHz LTE 2C	46.51	46.5	0.01
	High	10MHz LTE 2C	46.48	46.5	-0.02
Ref Offset	Ref offset=Cable & Attenuator & Coupler Attenuation=50.7dB				

TX2/RX2 Port TM 32 Waveform

PCS Band	Channel	Modulation	Power Output (dBm)	Rated Power (dBm)	Deviation
Downlink	Low	5MHz LTE 1C	46.26	46.5	-0.24
	Mid	5MHz LTE 1C	46.52	46.5	0.02
	High	5MHz LTE 1C	46.26	46.5	-0.24
	Low	10MHz LTE 1C	46.37	46.5	-0.13
	Mid	10MHz LTE 1C	46.56	46.5	0.06
	High	10MHz LTE 1C	46.36	46.5	-0.14
	Low	20MHz LTE 1C	46.58	46.5	0.08
	Mid	20MHz LTE 1C	46.69	46.5	0.19
	High	20MHz LTE 1C	46.57	46.5	0.07
	Low	5MHz LTE 2C	46.28	46.5	-0.22
	Mid	5MHz LTE 2C	46.31	46.5	-0.19
	High	5MHz LTE 2C	46.27	46.5	-0.23
	Low	10MHz LTE 2C	46.28	46.5	-0.22
	Mid	10MHz LTE 2C	46.42	46.5	-0.08
	High	10MHz LTE 2C	46.38	46.5	-0.12
Ref Offset	Ref offset=Cable & Attenuator & Coupler Attenuation=50.7dB				

Spectrum Analyzer PAR Measurements

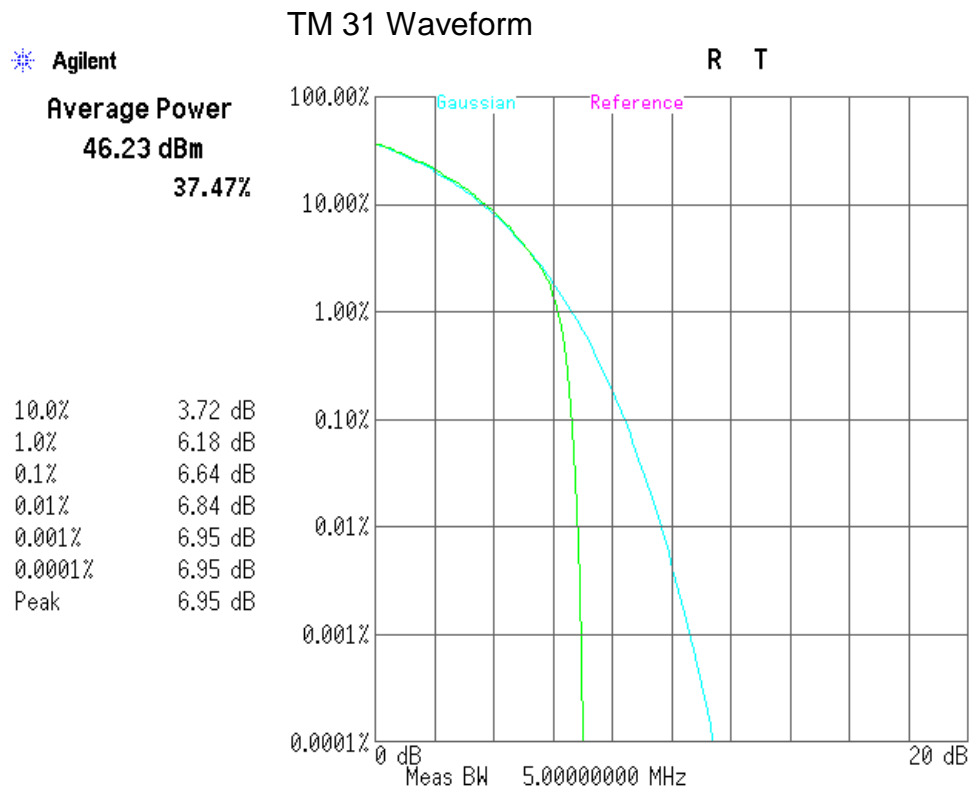
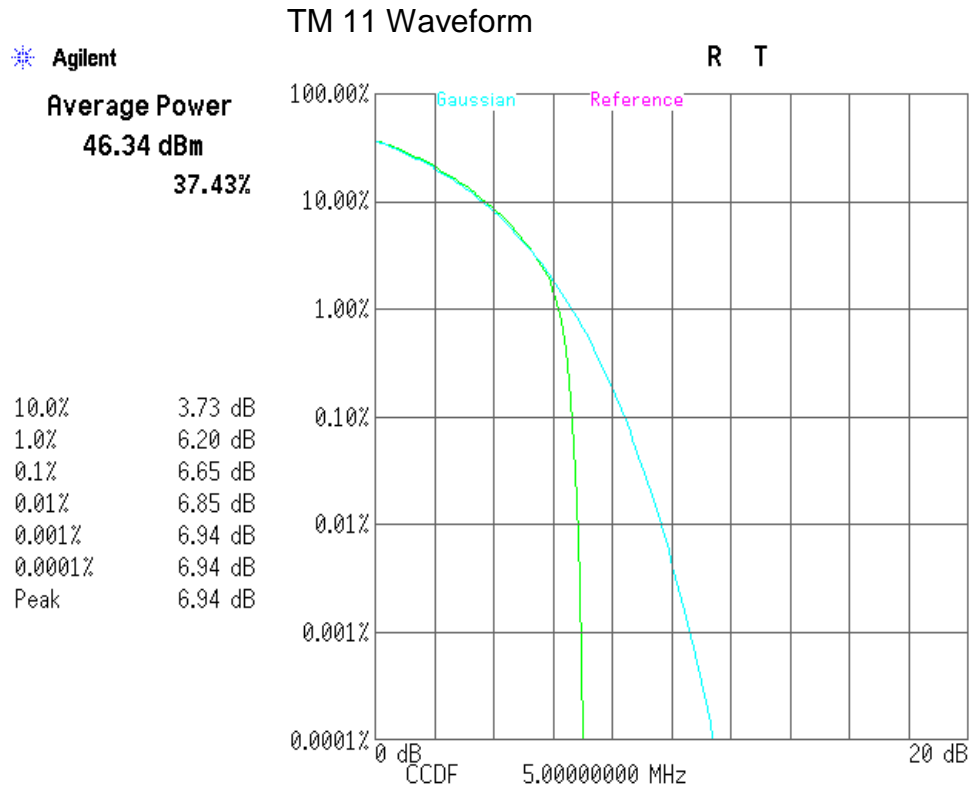

Spectrum Analyzer PAR Measurements (Continued)

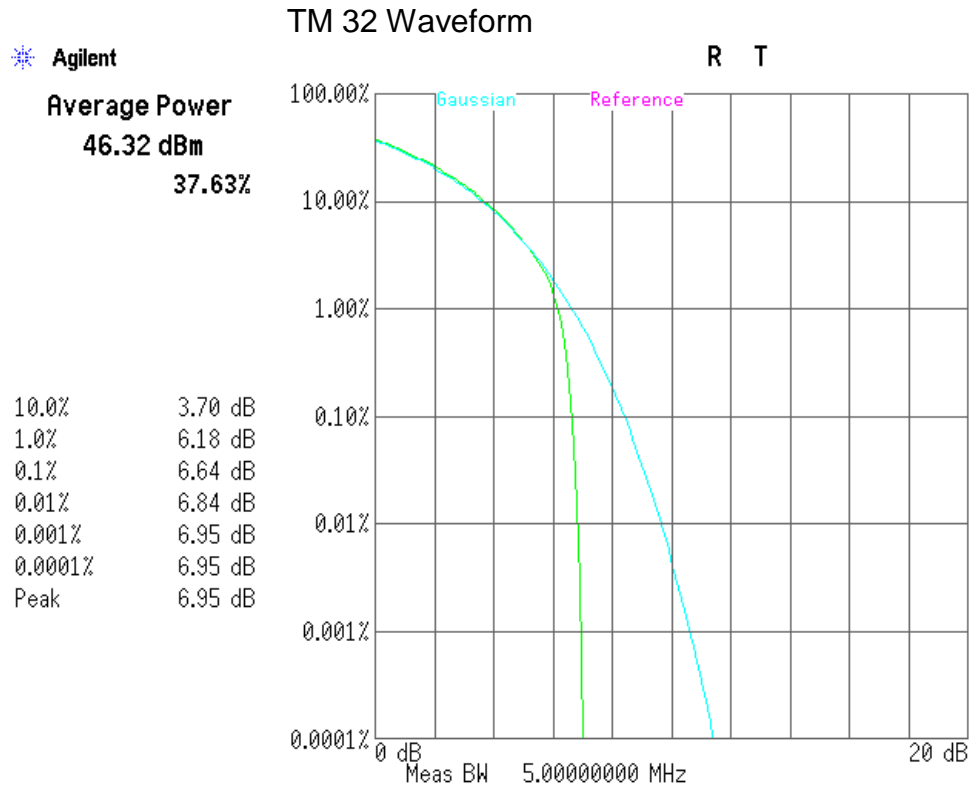

RF Output Power versus DC Input Voltage
(Mid-Band Frequency)**TX1/RX1 Port TM 11**

Carrier/Voltage	-39.5V	-48V	-57V
5M LTE 1C	46.71	46.59	46.58
10M LTE 1C	46.76	46.66	46.62
20M LTE 1C	46.89	46.83	46.76
5M LTE 2C	46.44	46.54	46.46
10M LTE 2C	46.46	46.62	46.49

TX2/RX2 Port TM 11

Carrier/Voltage	-39.5V	-48V	-57V
5M LTE 1C	46.63	46.6	46.44
10M LTE 1C	46.66	46.64	46.51
20M LTE 1C	46.8	46.78	46.63
5M LTE 2C	46.4	46.41	46.25
10M LTE 2C	46.37	46.5	46.35

TX1/RX1 Port TM 31

Carrier/Voltage	-39.5V	-48V	-57V
5M LTE 1C	46.53	46.49	46.53
10M LTE 1C	46.61	46.58	46.62
20M LTE 1C	46.74	46.65	46.67
5M LTE 2C	46.45	46.39	46.20
10M LTE 2C	46.51	46.43	46.38

TX2/RX2 Port TM 31

Carrier/Voltage	-39.5V	-48V	-57V
5M LTE 1C	46.49	46.45	46.49
10M LTE 1C	46.51	46.47	46.51
20M LTE 1C	46.67	46.65	46.65
5M LTE 2C	46.31	46.27	46.28
10M LTE 2C	46.38	46.39	46.35

RF Output Power versus DC Input Voltage (Continued)**TX1/RX1 Port TM 32**

Carrier/Voltage	-39.5V	-48V	-57V
5M LTE 1C	46.6	46.48	46.6
10M LTE 1C	46.62	46.57	46.62
20M LTE 1C	46.81	46.72	46.72
5M LTE 2C	46.45	46.44	46.42
10M LTE 2C	46.53	46.51	46.5

TX2/RX2 Port TM 32

Carrier/Voltage	-39.5V	-48V	-57V
5M LTE 1C	46.52	46.47	46.5
10M LTE 1C	46.56	46.53	46.56
20M LTE 1C	46.69	46.67	46.71
5M LTE 2C	46.31	46.31	46.34
10M LTE 2C	46.42	46.4	46.38

EIRP POWER CALCULATIONS:

Max EIRP at TX output port is 5MHz LTE case,

To calculate the spectral power in 1MHz, the following conversion must be made:

$$10 * \text{LOG} (5\text{MHz} / 1\text{MHz}) = 7 \text{ dB}$$

Therefore, $46.71 - 7 = 39.71\text{dBm/MHz}$.

Antenna's gain is 17.5dBi,

$$\text{EIRP} = 39.71 + 17.5 = 57.21\text{dBm/MHz}$$

FCC limit is $1640\text{W/MHz} = 62.1\text{dBm/MHz}$

Conclusion:

The two individual TX ports delivered the similar output RF power levels, 46.71dBm (46.88W) and 46.63dBm (46.03W). Each meets FCC power limit requirement based on the above calculation result.

Total combined Power= $46.88\text{W}+46.03\text{W}=92.91\text{W}$, ie. 49.68dBm.

EIRP(total)= $(49.68-7)+17.5=60.18\text{dBm}$, which is still under FCC limit (62.1dBm).

Considering the identical design between TX1 and TX2 RF paths, one of TX ports was chosen for completed testing suite. Selected tests was also performed on 2nd Tx port.

Section 4. Occupied Bandwidth

Name of Test:	<i>Occupied Bandwidth</i>	Test Standard:	<i>2.1049(i)</i>
Tested By:	WEI LI	Test Date:	06/17/2013-06/25/2013

Minimum Standard: Not defined by FCC. Input vs. Output.

Method of Measurement: Spectrum Analyzer Settings:
 RBW: 30kHz
 VBW: ≥ 3 RBW
 Span: As required
 Sweep: Auto
 Detector: Sampling
 Input Signal Characteristics: Generated from Digital Input
 RF level: Rated, recommended by manufacturer

Test Result:

Complies

Test Data:

Attached Plots

BW Configuration	Max. Measured 99% OBW (MHz)
5MHz	4.4901
10MHz	8.9816
20MHz	17.8869

Project Number:	0048-130617-01
EUT:	AA190045
PART NO.:	RF151032
Tested By:	Wei Li
Temperature:	70°F
Humidity:	30%

Section:	Occupied Bandwidth: PCS Bands
Plot Name:	Downlink, Hi-Channel, LTE TM 11 Modulation
Configuration:	Input: Digital, Output: TX1 RF OUTPUT 5MHz Carrier Bandwidth

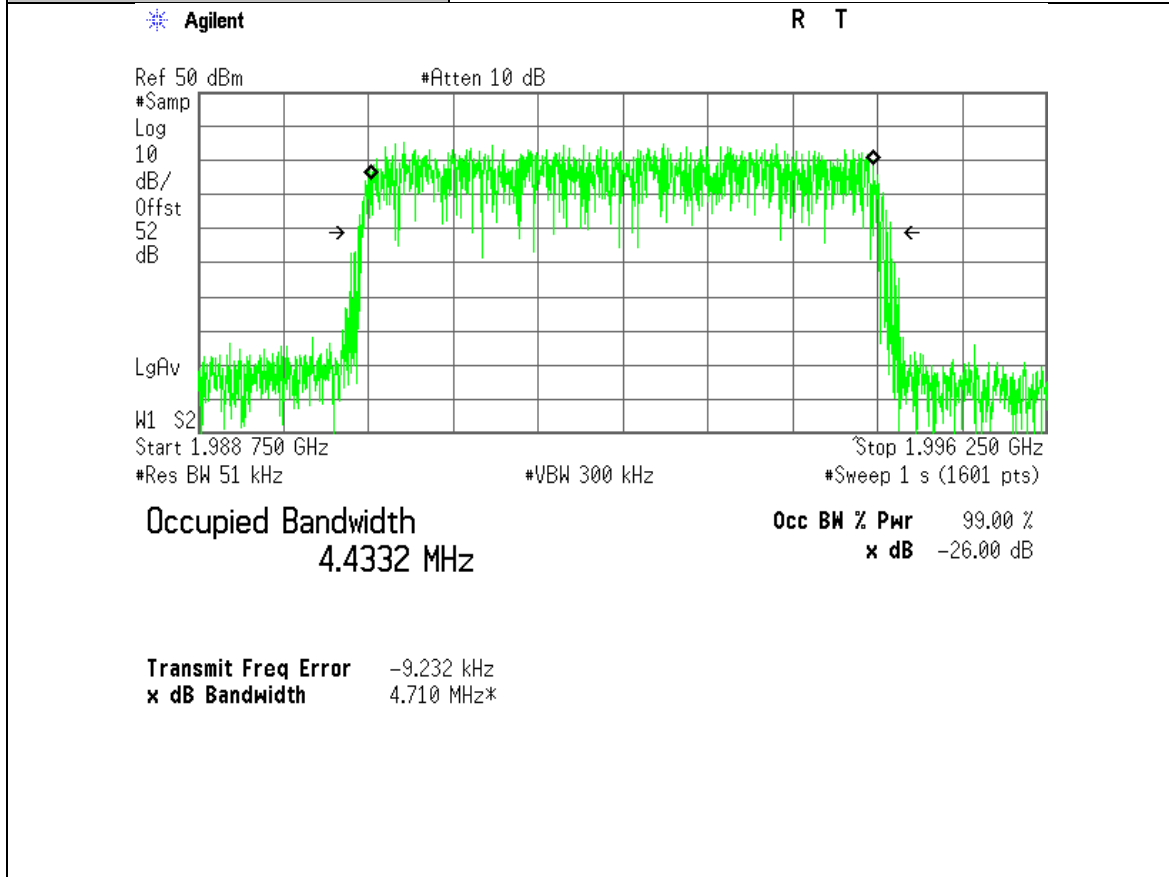

Project Number:	0048-130617-01
EUT:	AA190045
PART NO.:	RF151032
Tested By:	Wei Li
Temperature:	70°F
Humidity:	30%

Section:	Occupied Bandwidth: PCS Bands
Plot Name:	Downlink, Mid-Channel, LTE TM 11 Modulation
Configuration:	Input: Digital, Output: TX1 RF OUTPUT 5MHz Carrier Bandwidth

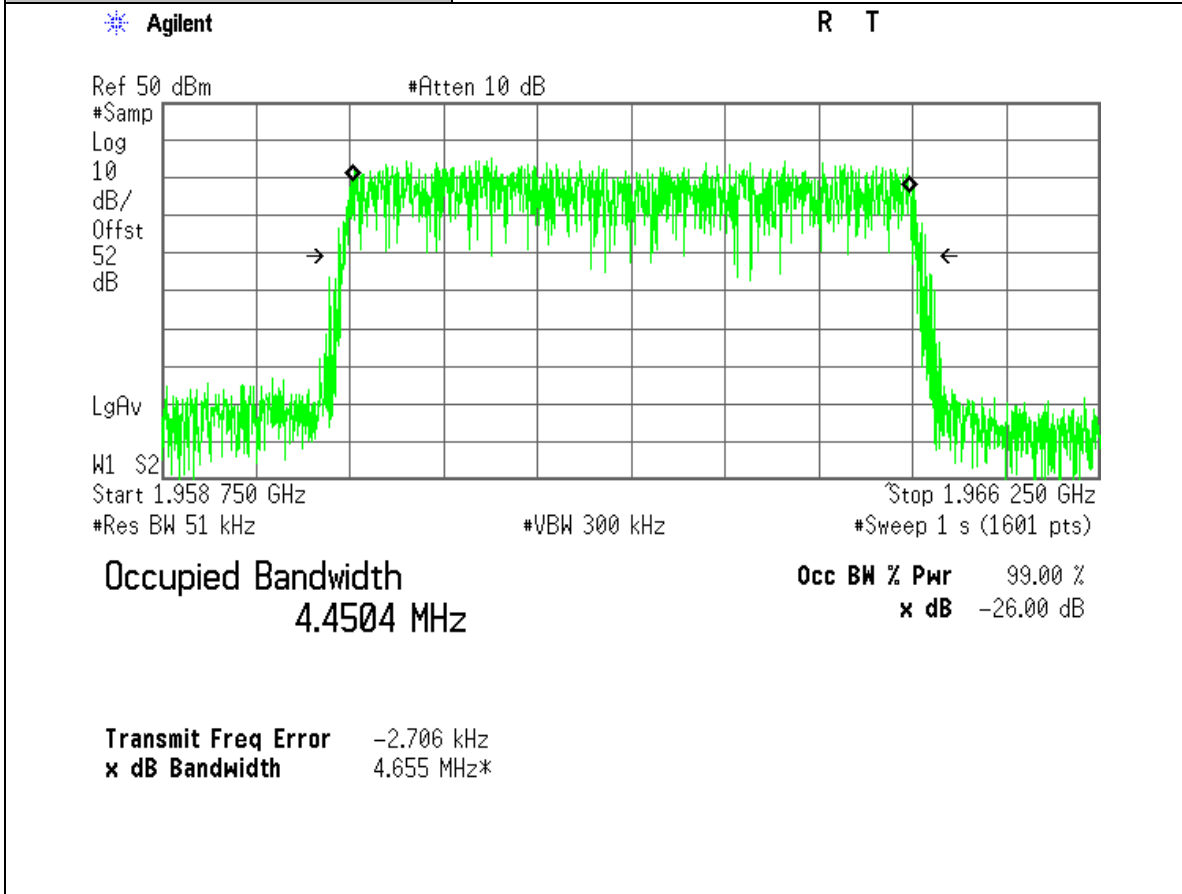

Project Number:	0048-130617-01
EUT:	AA190045
PART NO.:	RF151032
Tested By:	Wei Li
Temperature:	70°F
Humidity:	30%

Section:	Occupied Bandwidth: PCS Bands
Plot Name:	Downlink, Low-Channel, LTE TM11 Modulation
Configuration:	Input: Digital, Output: TX1 RF OUTPUT 5 MHz Carrier Bandwidth

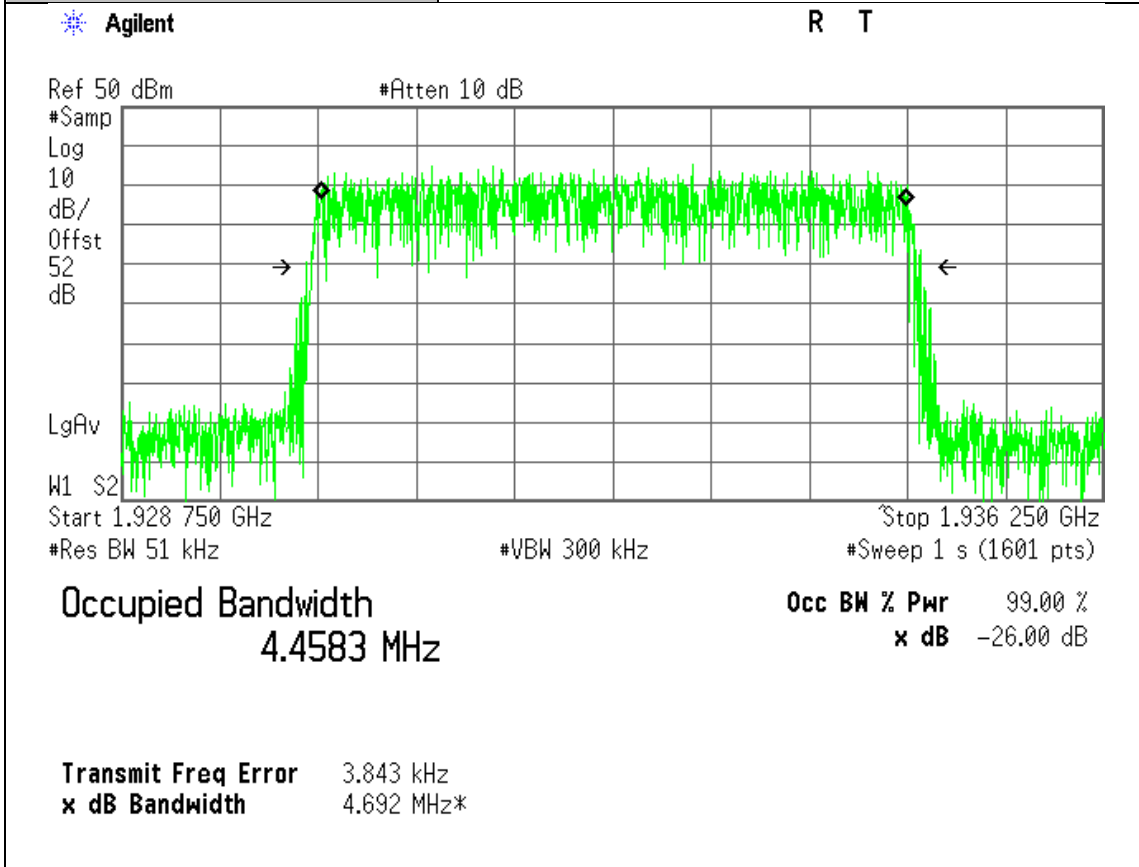

Project Number:	0048-130617-01
EUT:	AA190045
PART NO.:	RF151032
Tested By:	Wei Li
Temperature:	70°F
Humidity:	30%

Section:	Occupied Bandwidth: PCS Bands
Plot Name:	Downlink, Hi-Channel, LTE TM11 Modulation
Configuration:	Input: Digital, Output: TX1 RF OUTPUT 10MHz Carrier Bandwidth

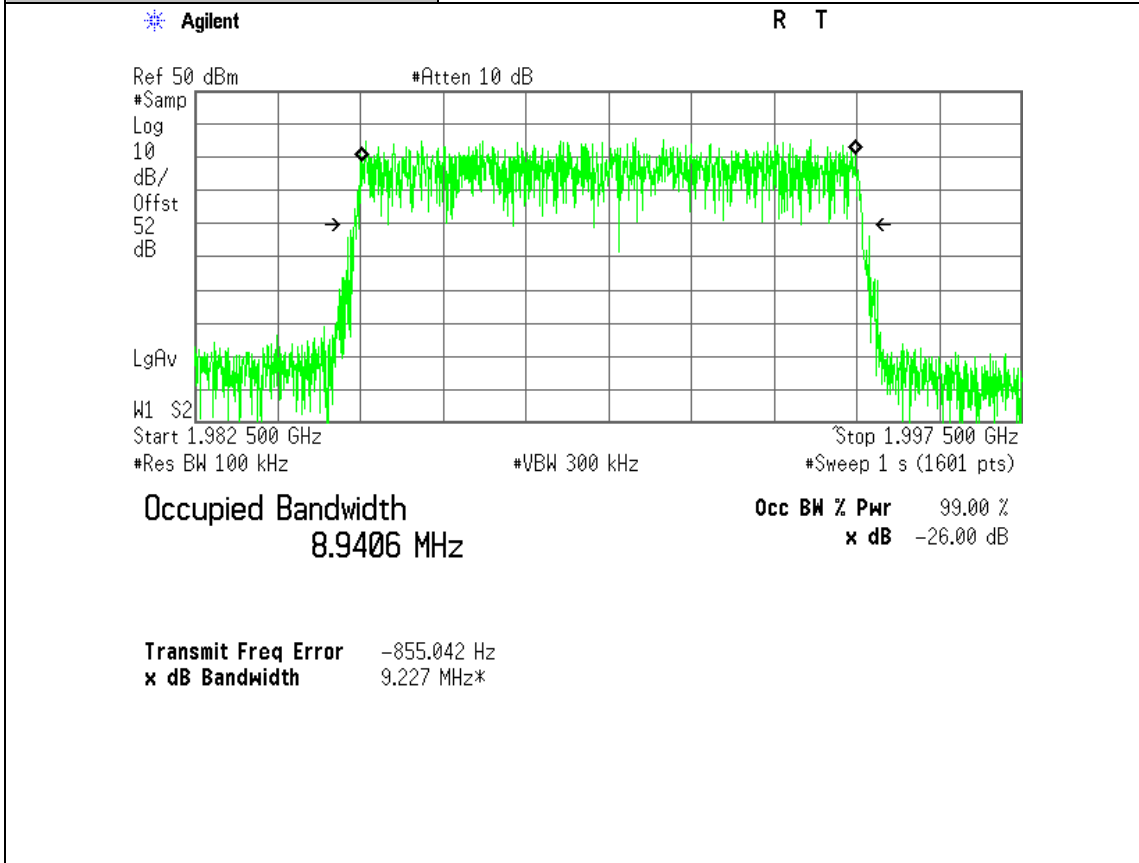

Project Number:	0048-130617-01
EUT:	AA190045
PART NO.:	RF151032
Tested By:	Wei Li
Temperature:	70°F
Humidity:	30%

Section:	Occupied Bandwidth: PCS Bands
Plot Name:	Downlink, Mid-Channel, LTE TM 11 Modulation
Configuration:	Input: Digital, Output: TX1 RF OUTPUT 10MHz Carrier Bandwidth

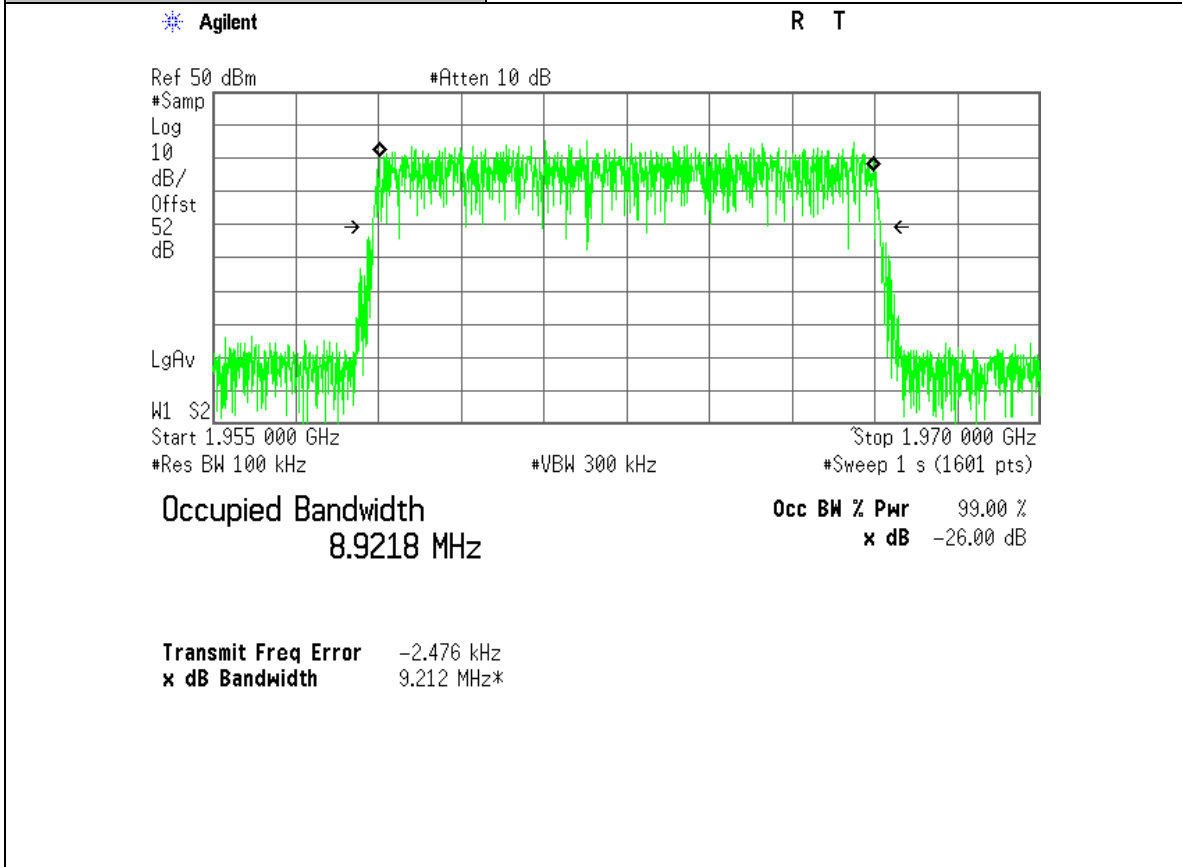

Project Number:	0048-130617-01
EUT:	AA190045
PART NO.:	RF151032
Tested By:	Wei Li
Temperature:	70°F
Humidity:	30%

Section:	Occupied Bandwidth: PCS Bands
Plot Name:	Downlink, Low-Channel, LTE TM 11
Configuration:	Input: Digital, Output: TX1 RF OUTPUT 10MHz Carrier Bandwidth

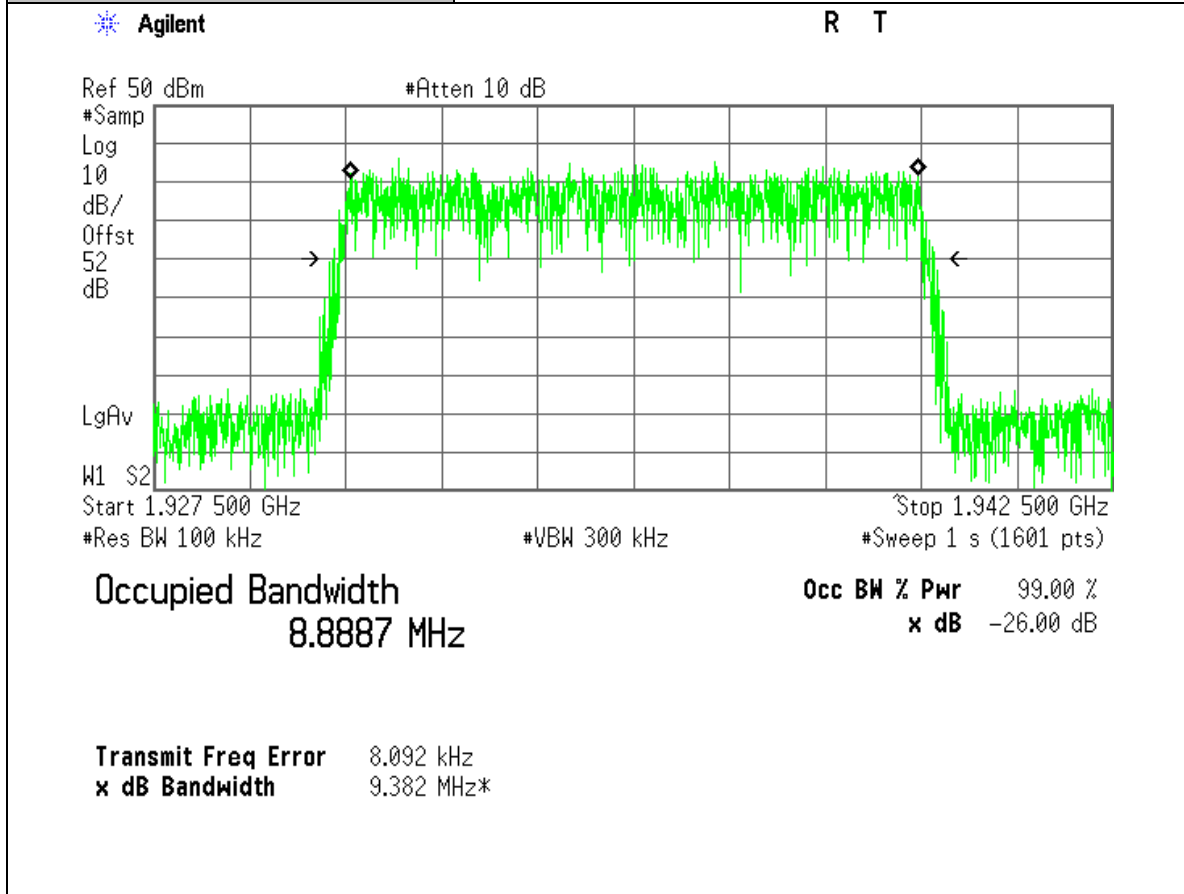

Project Number:	0048-130617-01
EUT:	AA190045
PART NO.:	RF151032
Tested By:	Wei Li
Temperature:	70°F
Humidity:	30%

Section:	Occupied Bandwidth: PCS Bands
Plot Name:	Downlink, Hi-Channel, LTE TM 11 Modulation
Configuration:	Input: Digital, Output: TX1 RF OUTPUT 20MHz Carrier Bandwidth

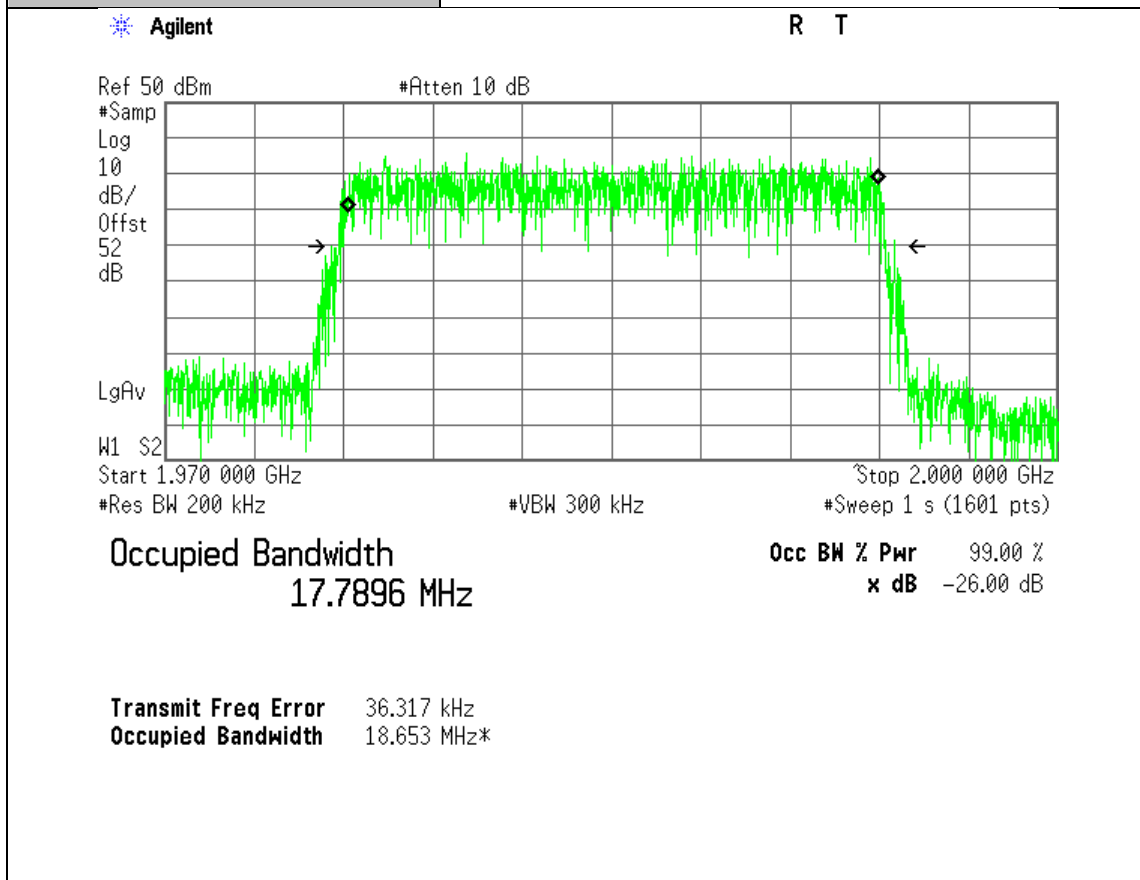

Project Number:	0048-130617-01
EUT:	AA190045
PART NO.:	RF151032
Tested By:	Wei Li
Temperature:	70°F
Humidity:	30%

Section:	Occupied Bandwidth: PCS Bands
Plot Name:	Downlink, Mid-Channel, LTE TM 11 Modulation
Configuration:	Input: Digital, Output: TX1 RF OUTPUT 20MHz Carrier Bandwidth

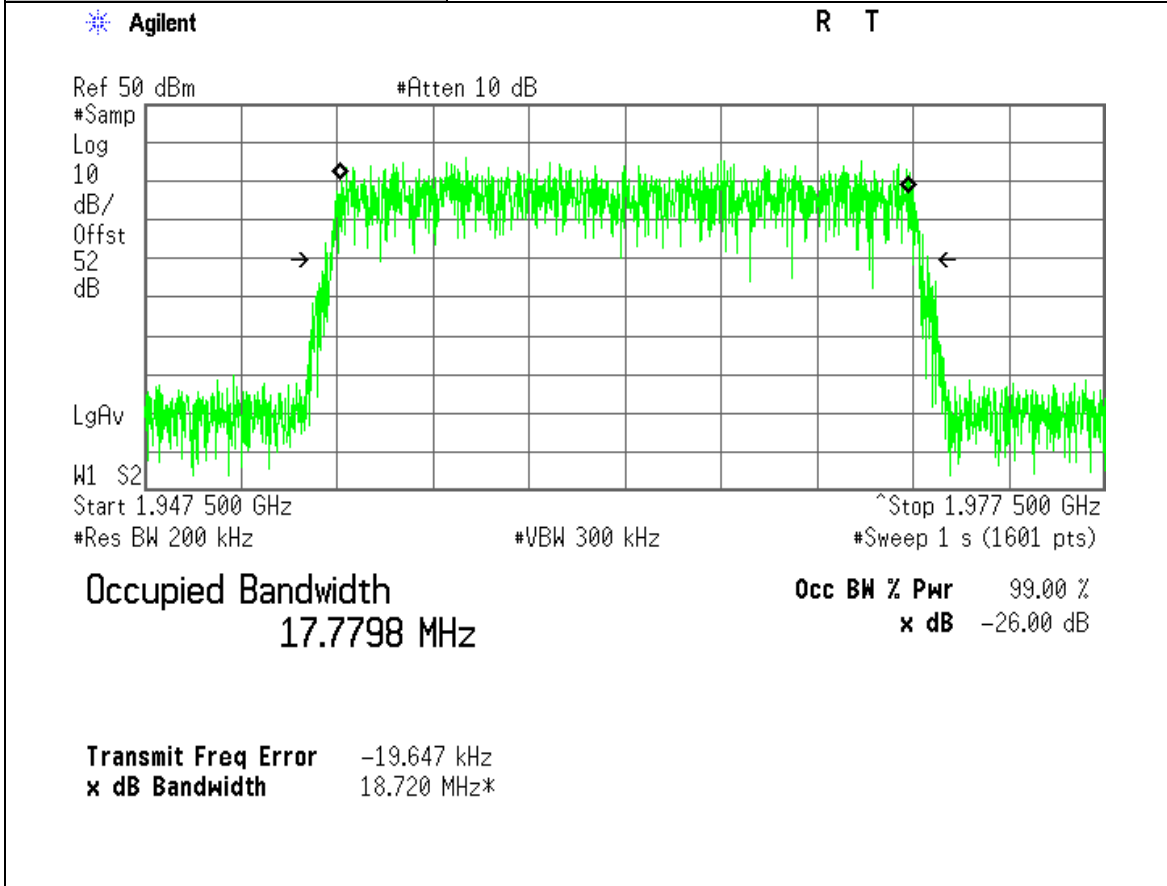

Project Number:	0048-130617-01
EUT:	AA190045
PART NO.:	RF151032
Tested By:	Wei Li
Temperature:	70°F
Humidity:	30%

Section:	Occupied Bandwidth: PCS Bands
Plot Name:	Downlink, Low-Channel, LTE TM 11 Modulation
Configuration:	Input: Digital, Output: TX1 RF OUTPUT 20MHz Carrier Bandwidth

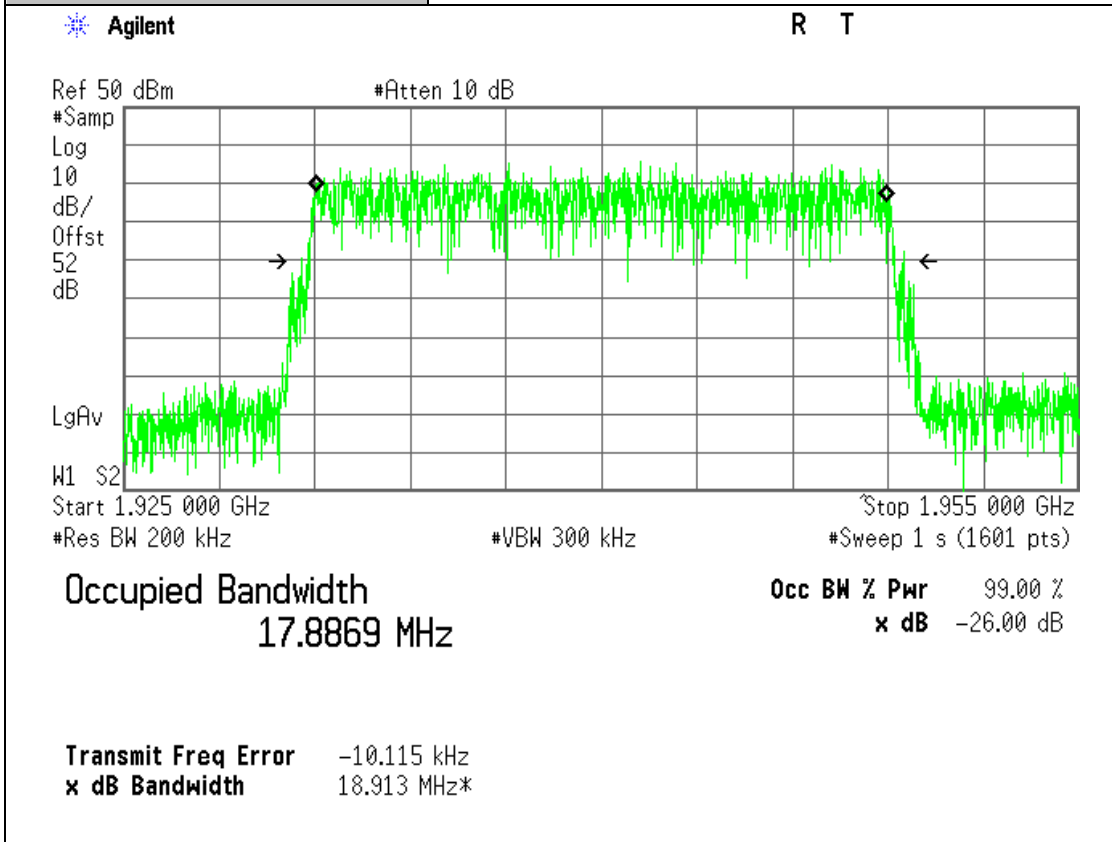

Project Number:	0048-130617-01
EUT:	AA190045
PART NO.:	RF151032
Tested By:	Wei Li
Temperature:	70°F
Humidity:	30%

Section:	Occupied Bandwidth: PCS Bands
Plot Name:	Downlink, Hi-Channel, LTE TM 11 Modulation
Configuration:	Input: Digital, Output: TX2 RF OUTPUT 5MHz Carrier Bandwidth

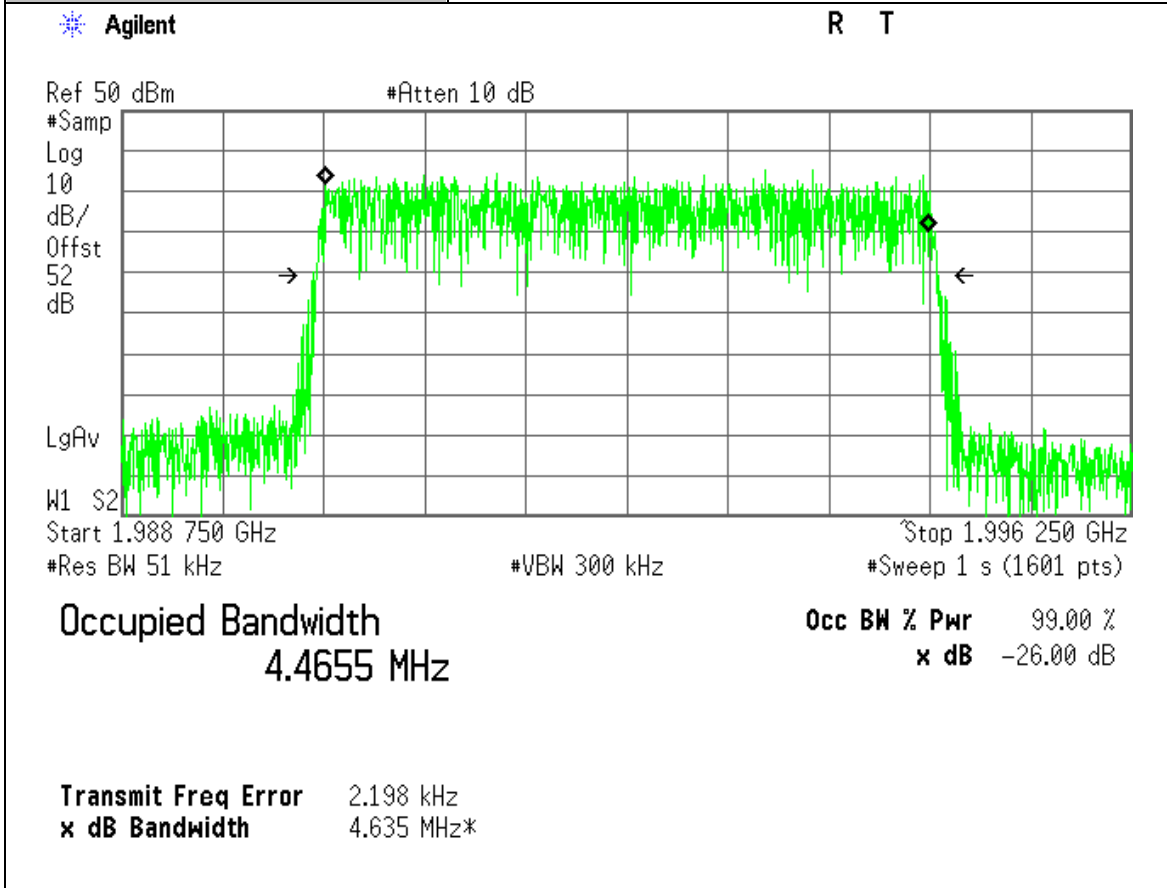

Project Number:	0048-130617-01
EUT:	AA190045
PART NO.:	RF151032
Tested By:	Wei Li
Temperature:	70°F
Humidity:	30%

Section:	Occupied Bandwidth: PCS Bands
Plot Name:	Downlink, Mid-Channel, LTE TM 11 Modulation
Configuration:	Input: Digital, Output: TX2 RF OUTPUT 5MHz Carrier Bandwidth

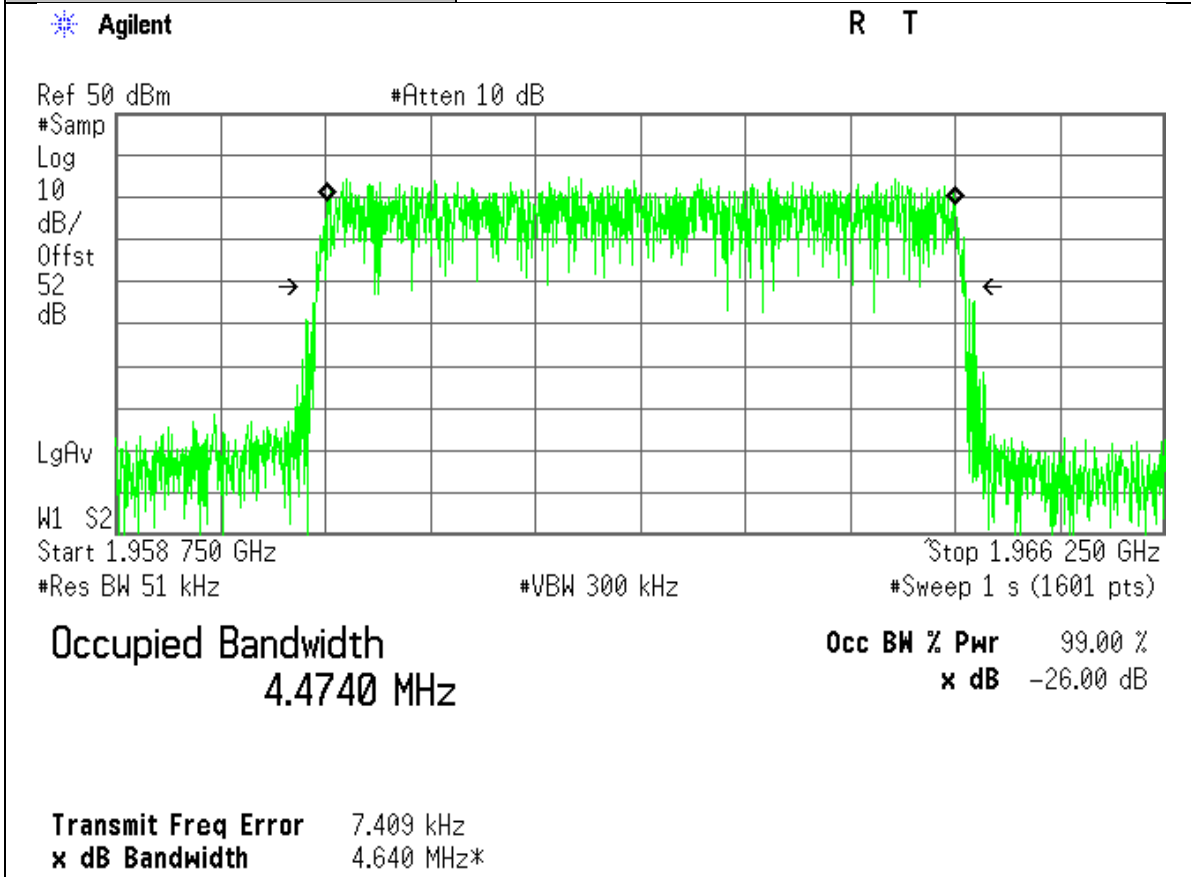

Project Number:	0048-130617-01
EUT:	AA190045
PART NO.:	RF151032
Tested By:	Wei Li
Temperature:	70°F
Humidity:	30%

Section:	Occupied Bandwidth: PCS Bands
Plot Name:	Downlink, Low-Channel, LTE TM 11 Modulation
Configuration:	Input: Digital, Output: TX2 RF OUTPUT 5MHz Carrier Bandwidth

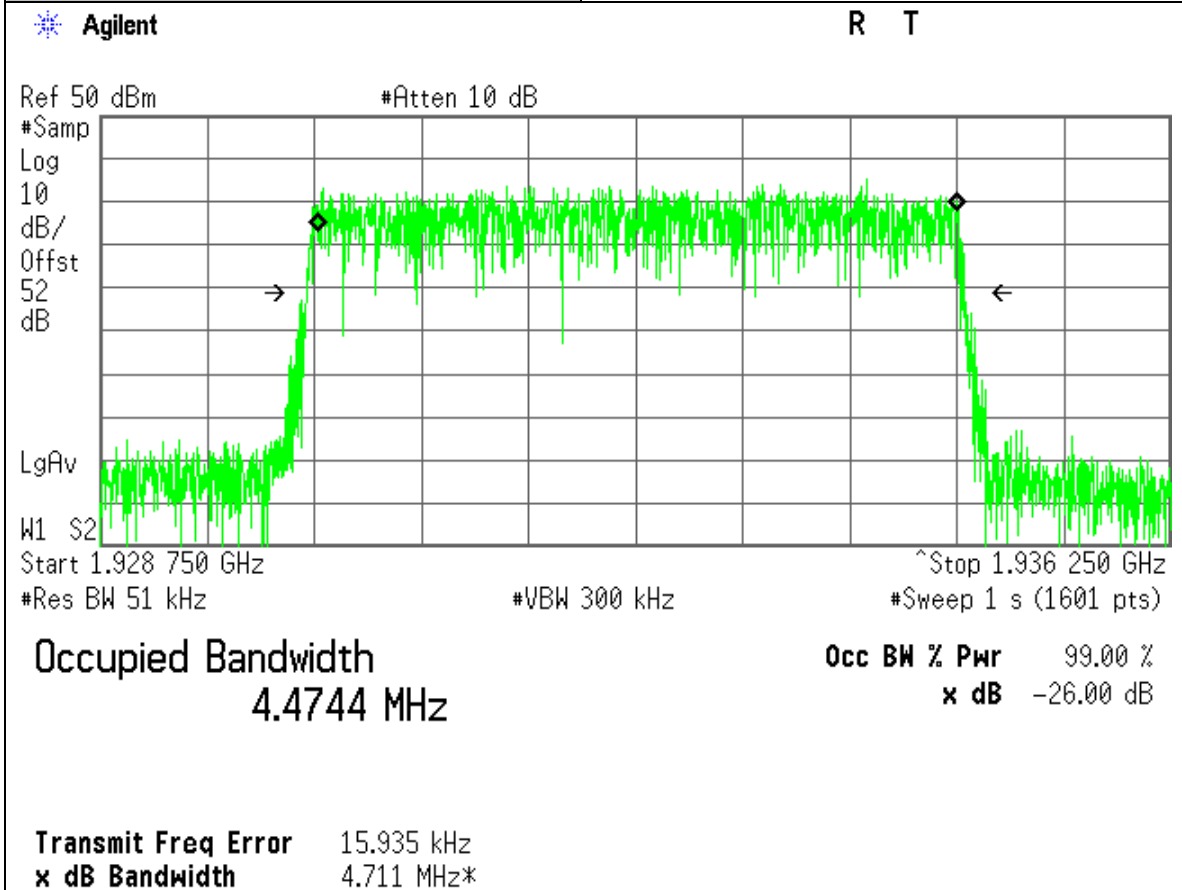

Project Number:	0048-130617-01
EUT:	AA190045
PART NO.:	RF151032
Tested By:	Wei Li
Temperature:	70°F
Humidity:	30%

Section:	Occupied Bandwidth: PCS Bands
Plot Name:	Downlink, Hi-Channel, LTE TM 11 Modulation
Configuration:	Input: Digital, Output: TX2 RF OUTPUT 10 MHz Carrier Bandwidth

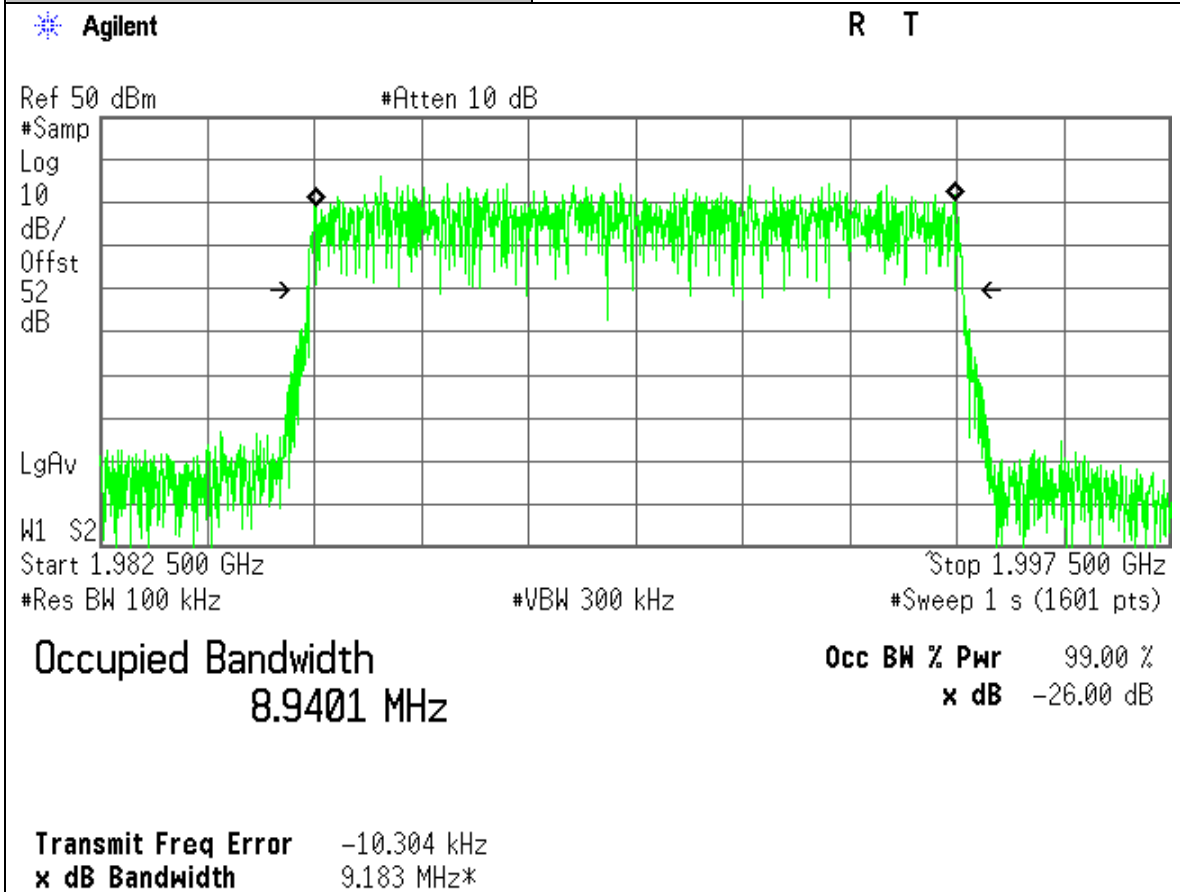

Project Number:	0048-130617-01
EUT:	AA190045
PART NO.:	RF151032
Tested By:	Wei Li
Temperature:	70°F
Humidity:	30%

Section:	Occupied Bandwidth: PCS Bands
Plot Name:	Downlink, Mid-Channel, LTE TM 11 Modulation
Configuration:	Input: Digital, Output: TX2 RF OUTPUT 10 MHz Carrier Bandwidth

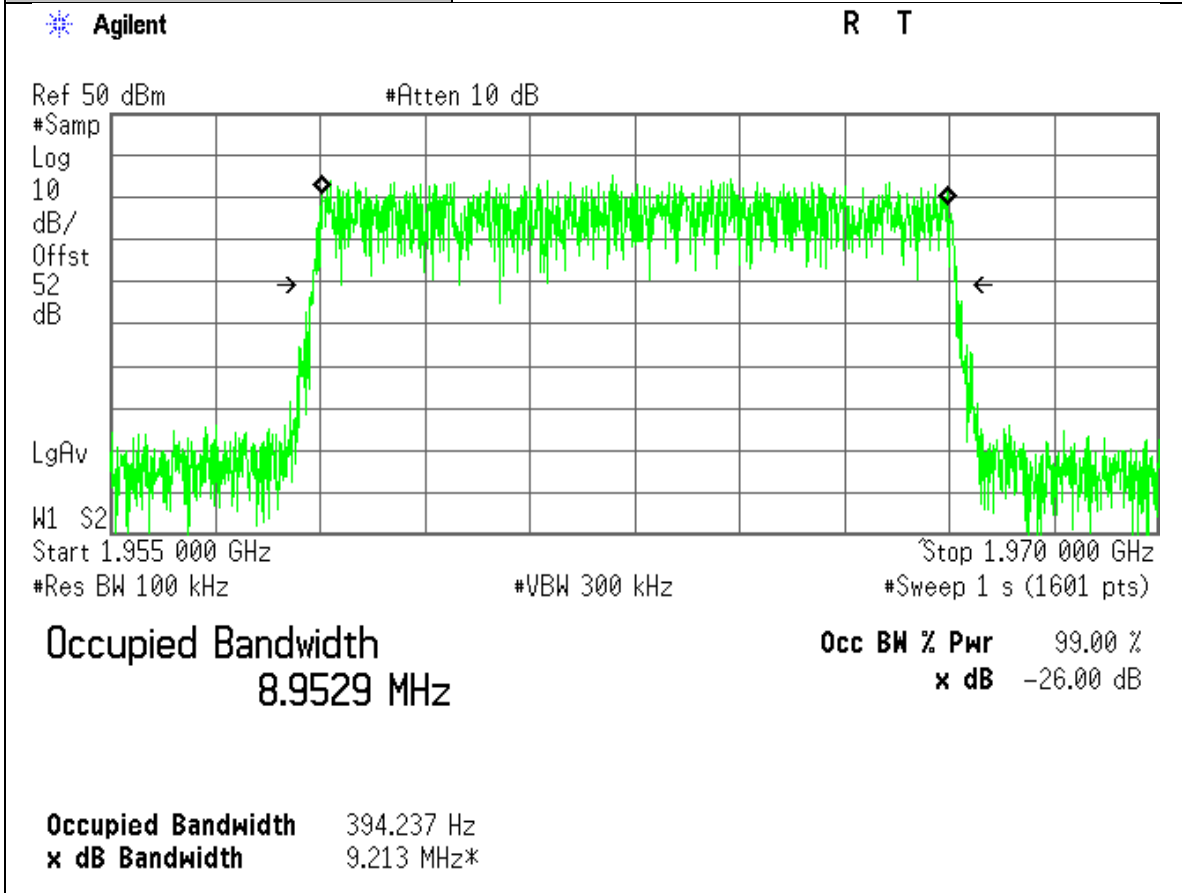

Project Number:	0048-130617-01
EUT:	AA190045
PART NO.:	RF151032
Tested By:	Wei Li
Temperature:	70°F
Humidity:	30%

Section:	Occupied Bandwidth: PCS Bands
Plot Name:	Downlink, Low-Channel, LTE TM 11 Modulation
Configuration:	Input: Digital, Output: TX2 RF OUTPUT 10 MHz Carrier Bandwidth

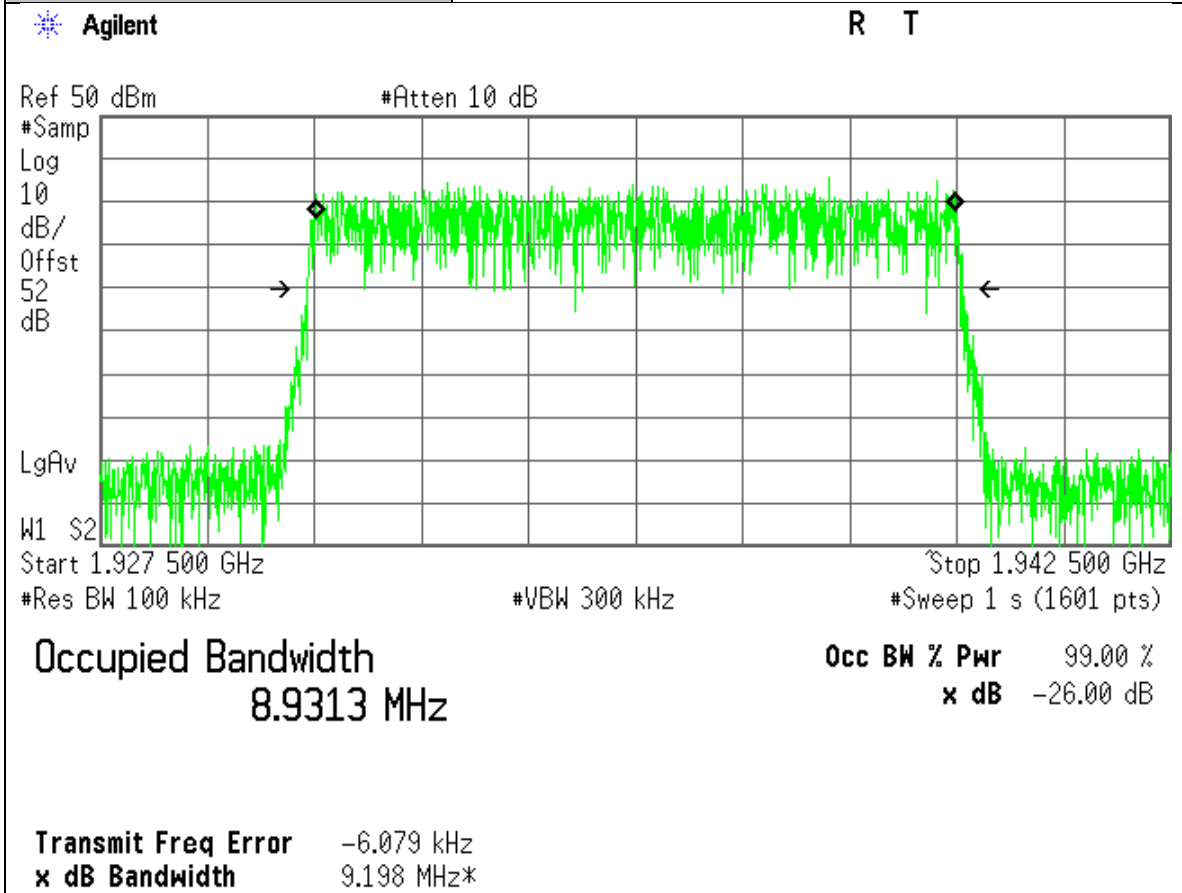

Project Number:	0048-130617-01
EUT:	AA190045
PART NO.:	RF151032
Tested By:	Wei Li
Temperature:	70°F
Humidity:	30%

Section:	Occupied Bandwidth: PCS Bands
Plot Name:	Downlink, Hi-Channel, LTE TM 11 Modulation
Configuration:	Input: Digital, Output: TX2 RF OUTPUT 20 MHz Carrier Bandwidth

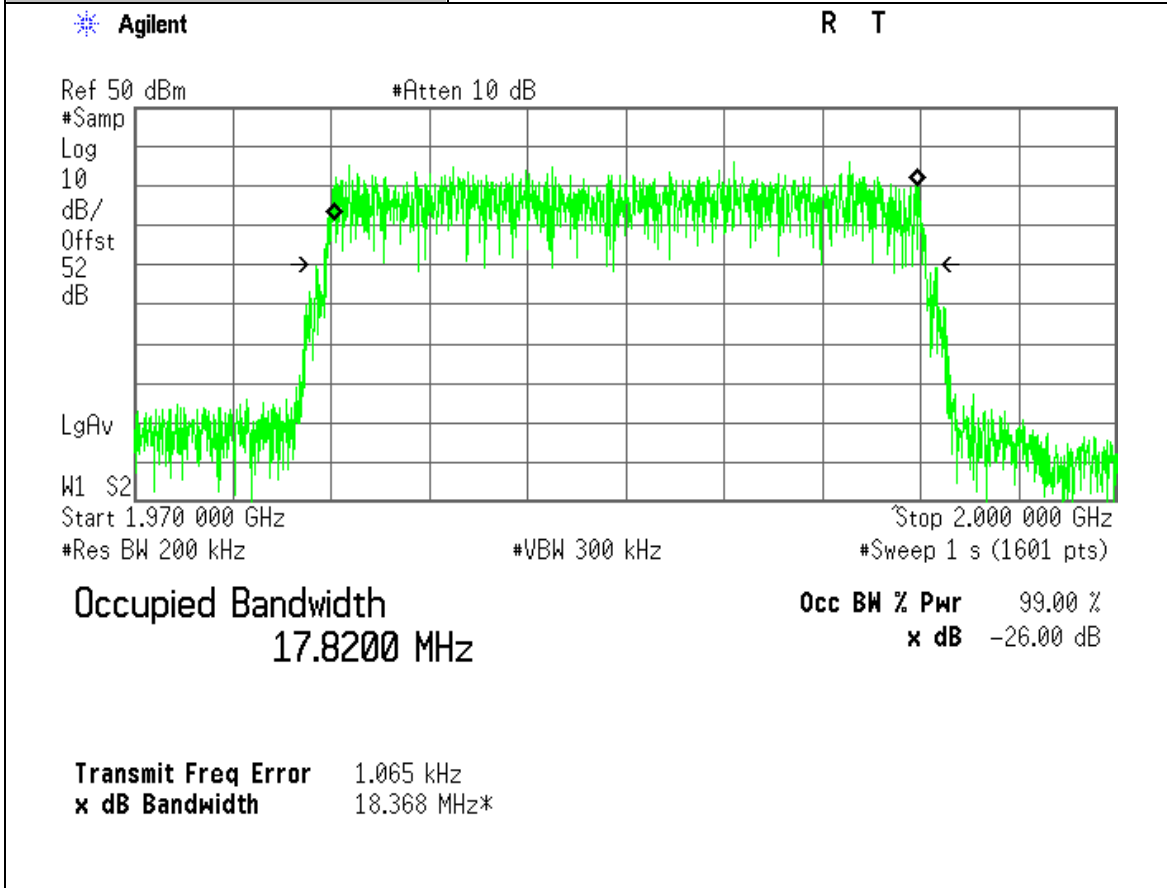

Project Number:	0048-130617-01
EUT:	AA190045
PART NO.:	RF151032
Tested By:	Wei Li
Temperature:	70°F
Humidity:	30%

Section:	Occupied Bandwidth: PCS Bands
Plot Name:	Downlink, Mid-Channel, LTE TM 11 Modulation
Configuration:	Input: Digital, Output: TX2 RF OUTPUT 20 MHz Carrier Bandwidth

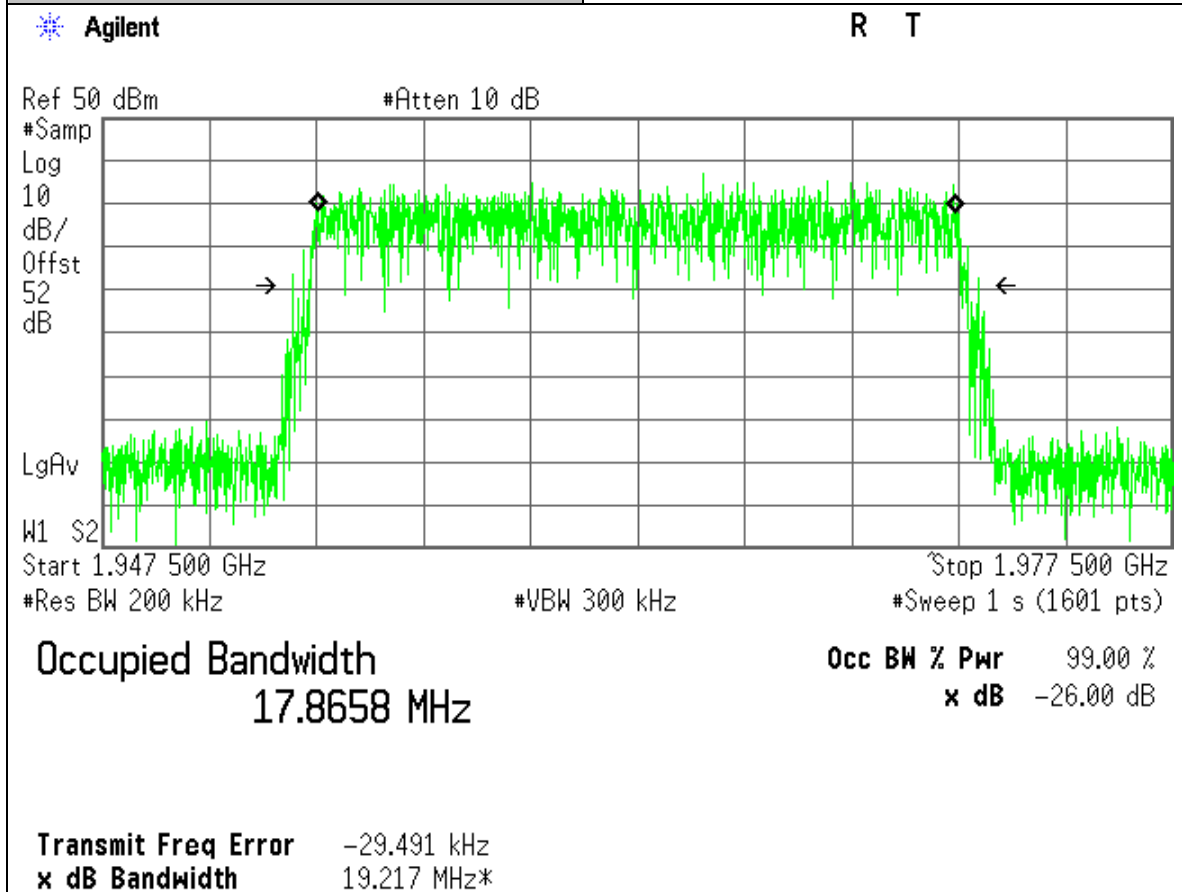

Project Number:	0048-130617-01
EUT:	AA190045
PART NO.:	RF151032
Tested By:	Wei Li
Temperature:	70°F
Humidity:	30%

Section:	Occupied Bandwidth: PCS Bands
Plot Name:	Downlink, Low-Channel, LTE TM 11 Modulation
Configuration:	Input: Digital, Output: TX2 RF OUTPUT 20 MHz Carrier Bandwidth

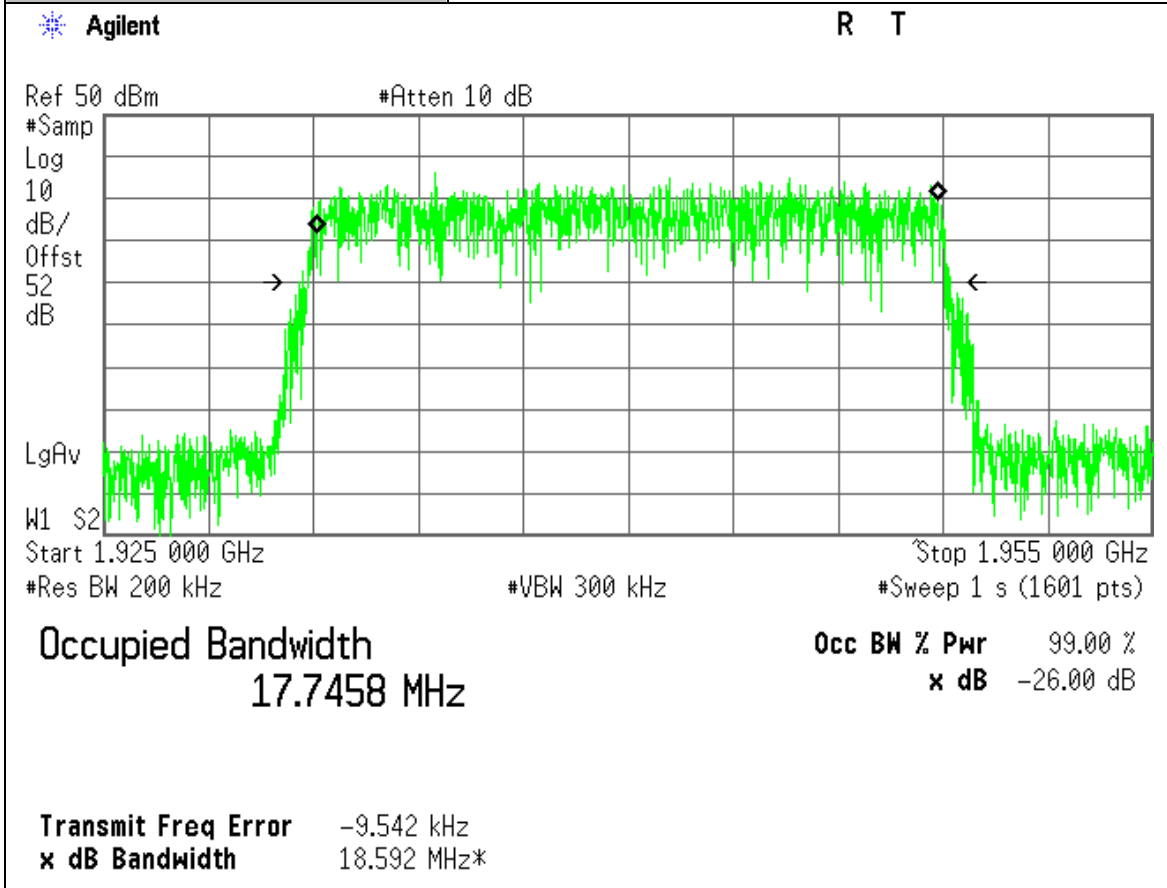

Project Number:	0048-130617-01
EUT:	AA190045
PART NO.:	RF151032
Tested By:	Wei Li
Temperature:	70°F
Humidity:	30%

Section:	Occupied Bandwidth: PCS Bands
Plot Name:	Downlink, Hi-Channel, LTE TM 31 Modulation
Configuration:	Input: Digital, Output: TX1 RF OUTPUT 5MHz Carrier Bandwidth

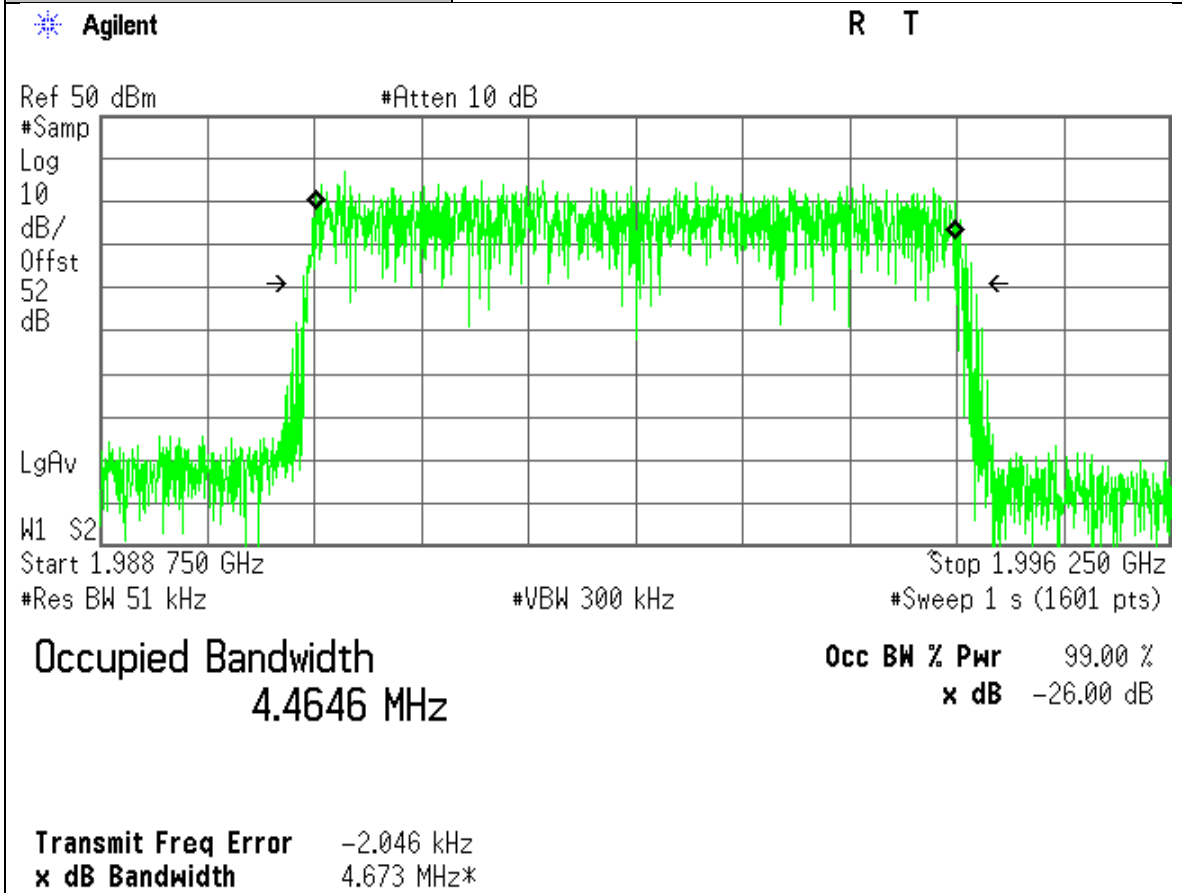

Project Number:	0048-130617-01
EUT:	AA190045
PART NO.:	RF151032
Tested By:	Wei Li
Temperature:	70°F
Humidity:	30%

Section:	Occupied Bandwidth: PCS Bands
Plot Name:	Downlink, Mid-Channel, LTE TM 31 Modulation
Configuration:	Input: Digital, Output: TX1 RF OUTPUT 5MHz Carrier Bandwidth

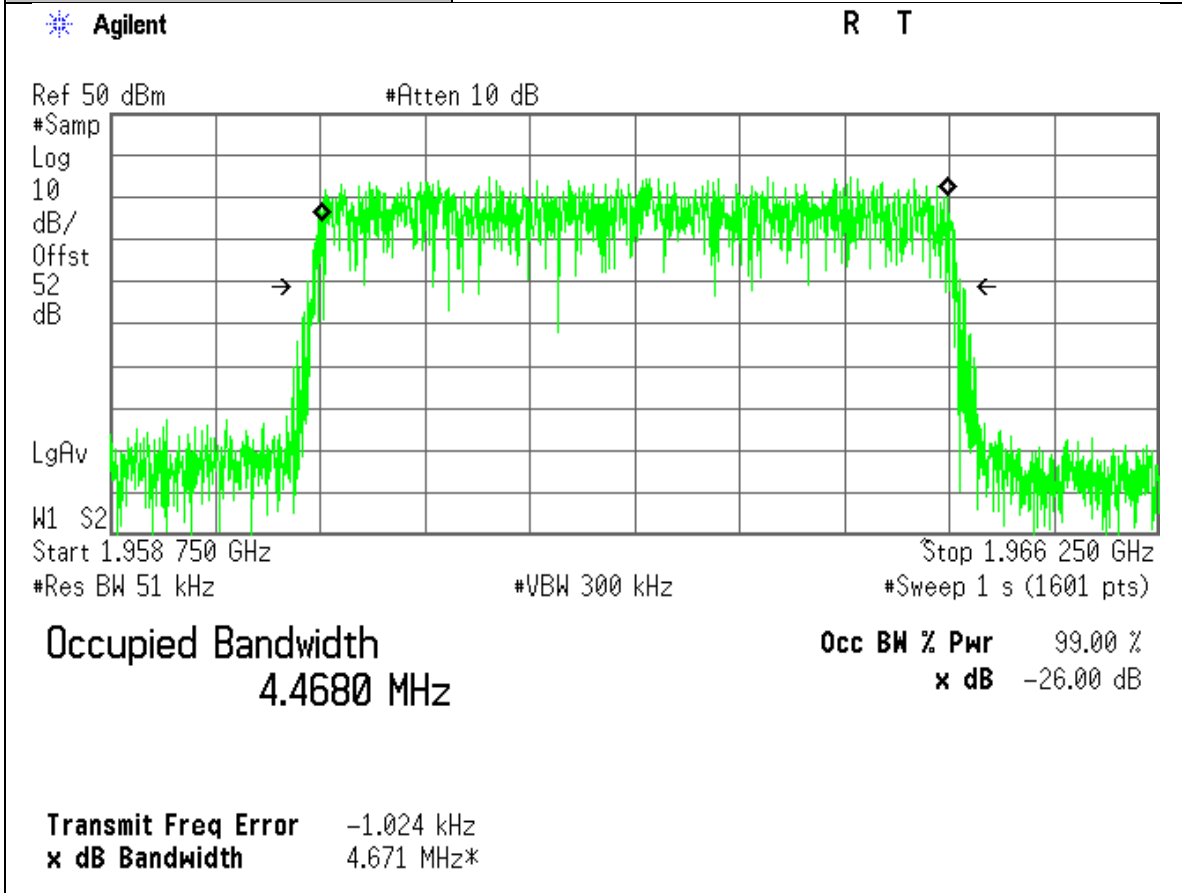

Project Number:	0048-130617-01
EUT:	AA190045
PART NO.:	RF151032
Tested By:	Wei Li
Temperature:	70°F
Humidity:	30%

Section:	Occupied Bandwidth: PCS Bands
Plot Name:	Downlink, Low-Channel, LTE TM 31 Modulation
Configuration:	Input: Digital, Output: TX1 RF OUTPUT 5MHz Carrier Bandwidth

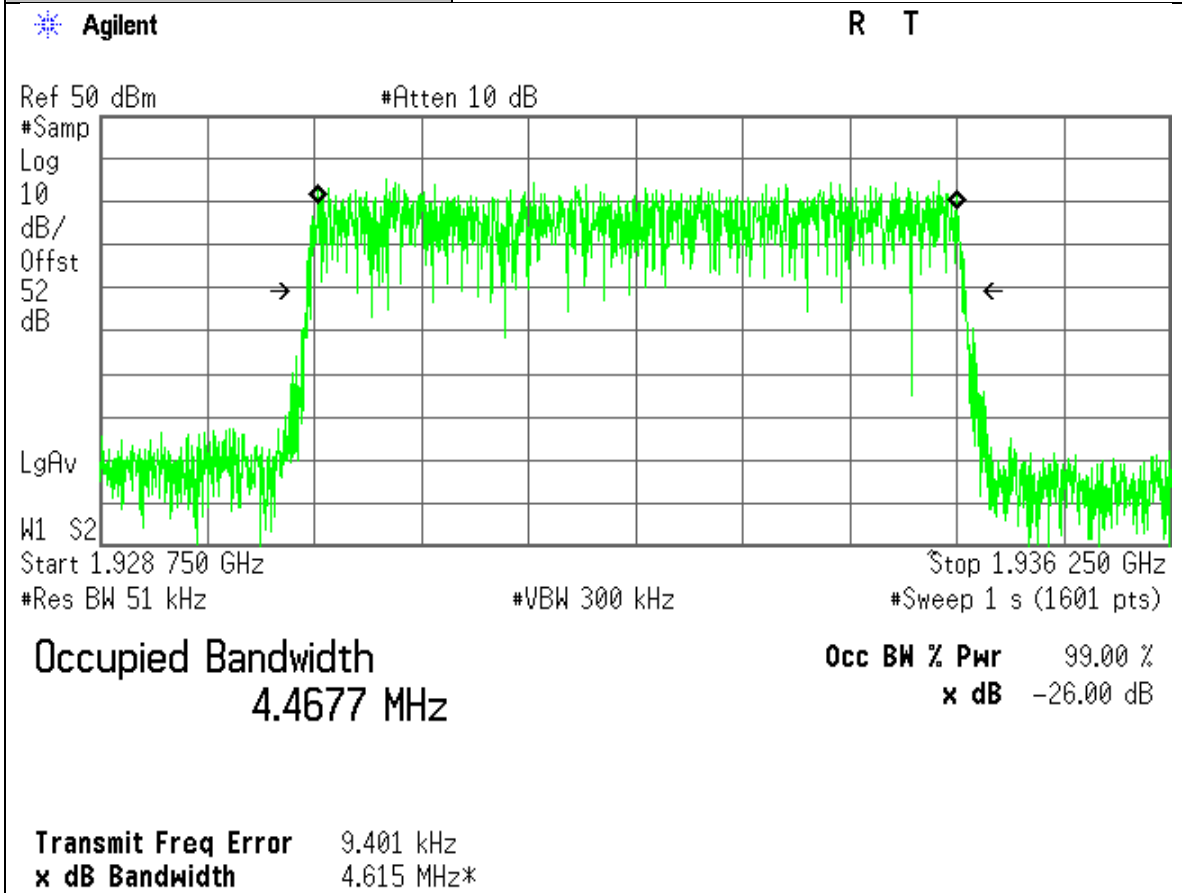

Project Number:	0048-130617-01
EUT:	AA190045
PART NO.:	RF151032
Tested By:	Wei Li
Temperature:	70°F
Humidity:	30%

Section:	Occupied Bandwidth: PCS Bands
Plot Name:	Downlink, Hi-Channel, LTE TM 31 Modulation
Configuration:	Input: Digital, Output: TX1 RF OUTPUT 10MHz Carrier Bandwidth

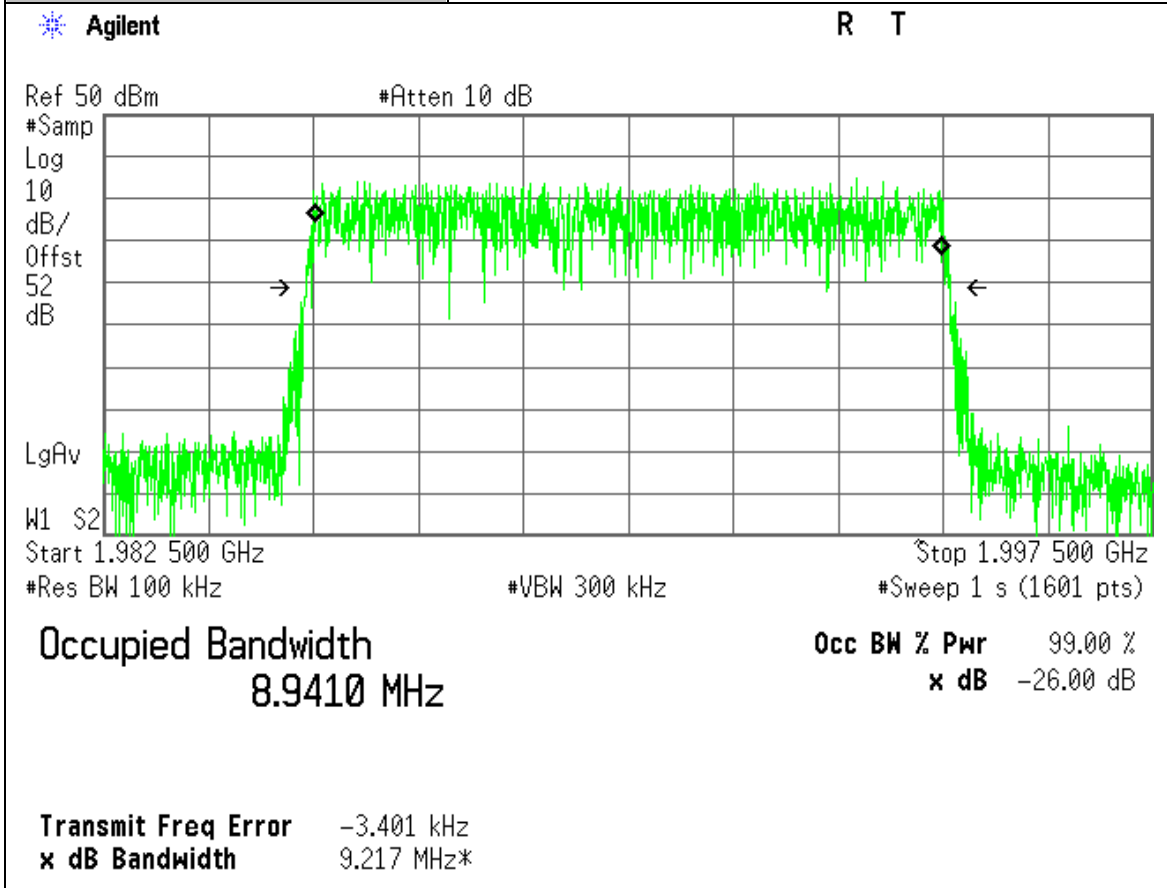

Project Number:	0048-130617-01
EUT:	AA190045
PART NO.:	RF151032
Tested By:	Wei Li
Temperature:	70°F
Humidity:	30%

Section:	Occupied Bandwidth: PCS Bands
Plot Name:	Downlink, Mid-Channel, LTE TM 31 Modulation
Configuration:	Input: Digital, Output: TX1 RF OUTPUT 10MHz Carrier Bandwidth

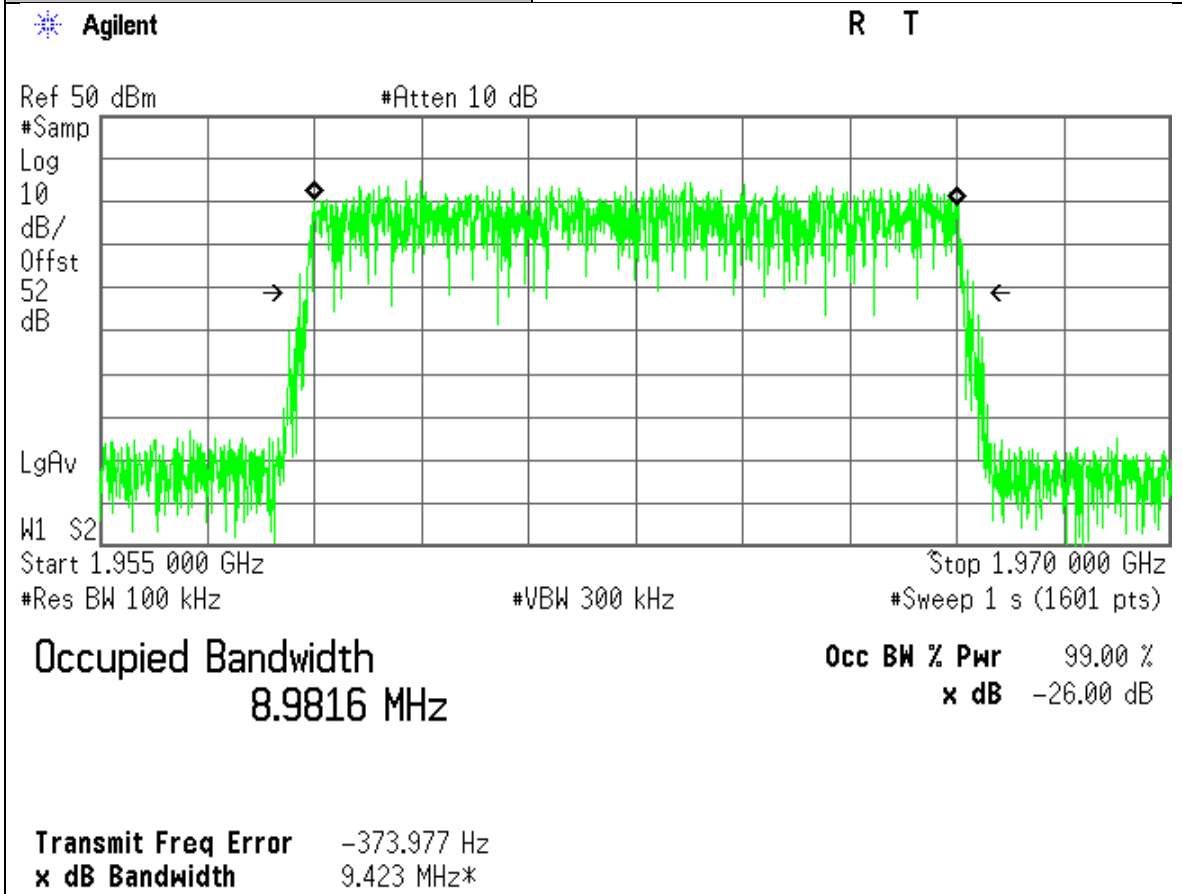

Project Number:	0048-130617-01
EUT:	AA190045
PART NO.:	RF151032
Tested By:	Wei Li
Temperature:	70°F
Humidity:	30%

Section:	Occupied Bandwidth: PCS Bands
Plot Name:	Downlink, Low-Channel, LTE TM 31 Modulation
Configuration:	Input: Digital, Output: TX1 RF OUTPUT 10MHz Carrier Bandwidth

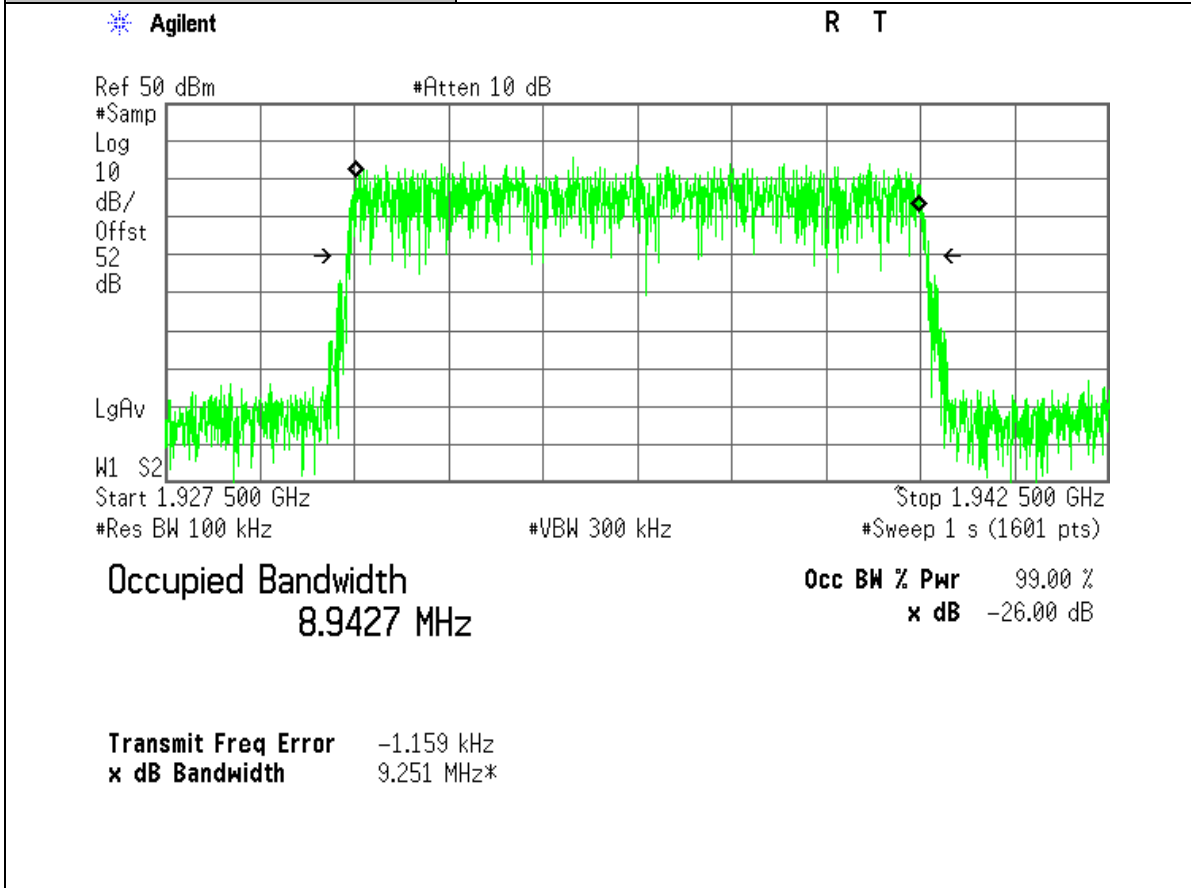

Project Number:	0048-130617-01
EUT:	AA190045
PART NO.:	RF151032
Tested By:	Wei Li
Temperature:	70°F
Humidity:	30%

Section:	Occupied Bandwidth: PCS Bands
Plot Name:	Downlink, Hi-Channel, LTE TM 31 Modulation
Configuration:	Input: Digital, Output: TX1 RF OUTPUT 20MHz Carrier Bandwidth

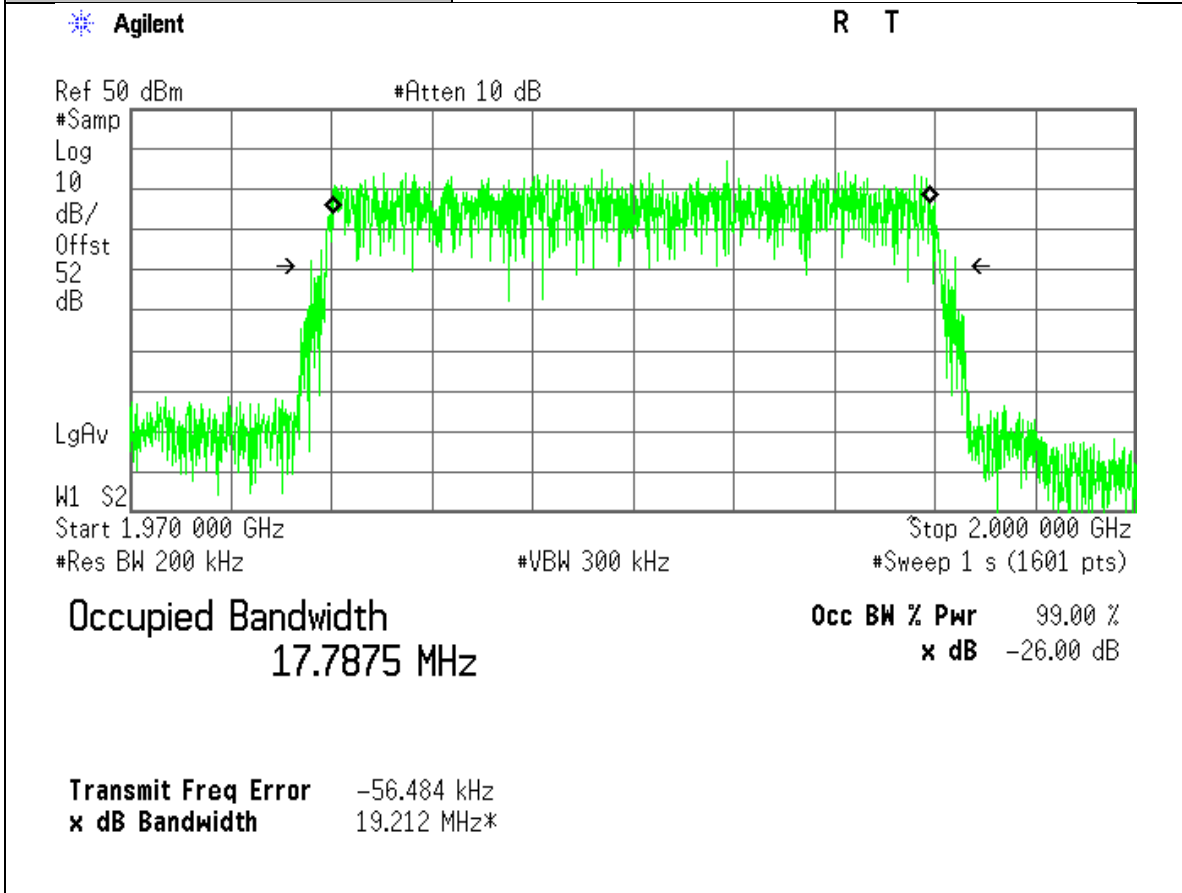

Project Number:	0048-130617-01
EUT:	AA190045
PART NO.:	RF151032
Tested By:	Wei Li
Temperature:	70°F
Humidity:	30%

Section:	Occupied Bandwidth: PCS Bands
Plot Name:	Downlink, Mid-Channel, LTE TM 31 Modulation
Configuration:	Input: Digital, Output: TX1 RF OUTPUT 20MHz Carrier Bandwidth

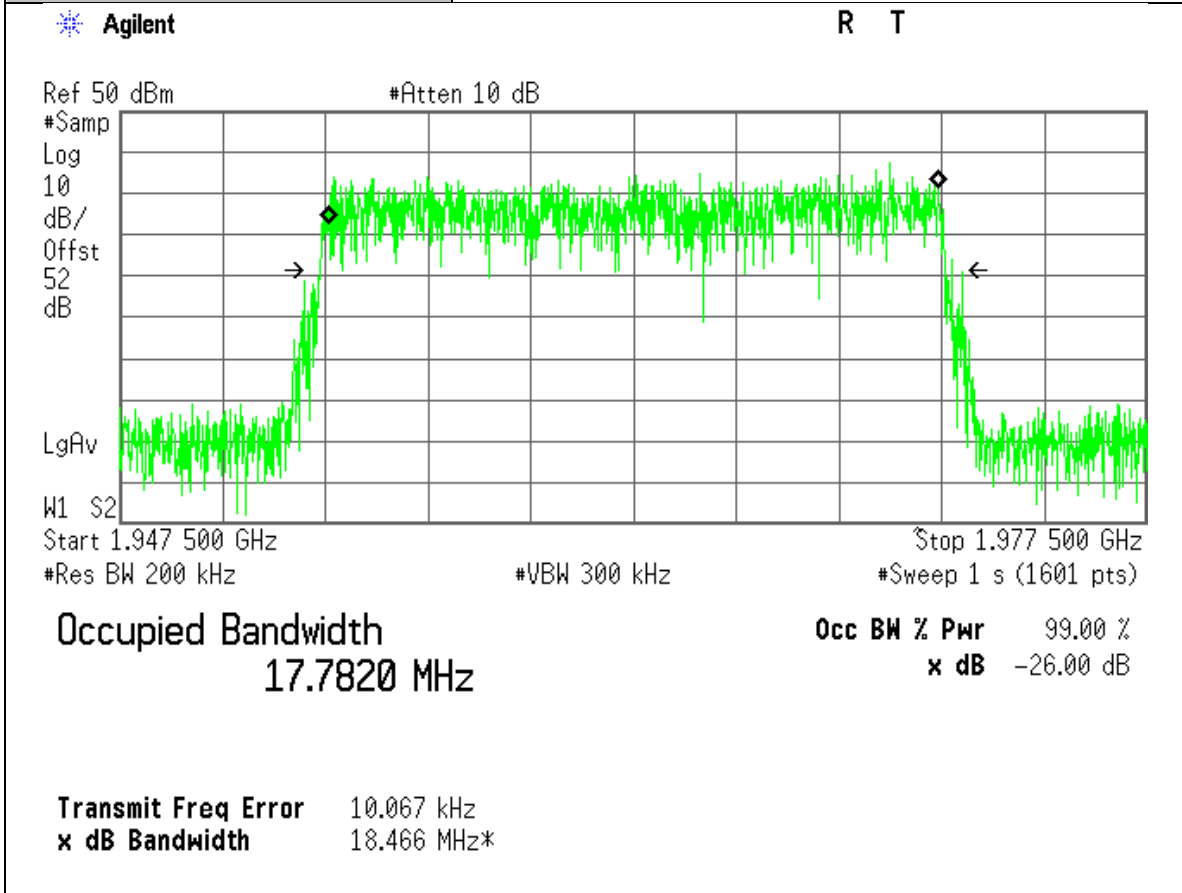

Project Number:	0048-130617-01
EUT:	AA190045
PART NO.:	RF151032
Tested By:	Wei Li
Temperature:	70°F
Humidity:	30%

Section:	Occupied Bandwidth: PCS Bands
Plot Name:	Downlink, Low-Channel, LTE TM 31 Modulation
Configuration:	Input: Digital, Output: TX1 RF OUTPUT 20MHz Carrier Bandwidth

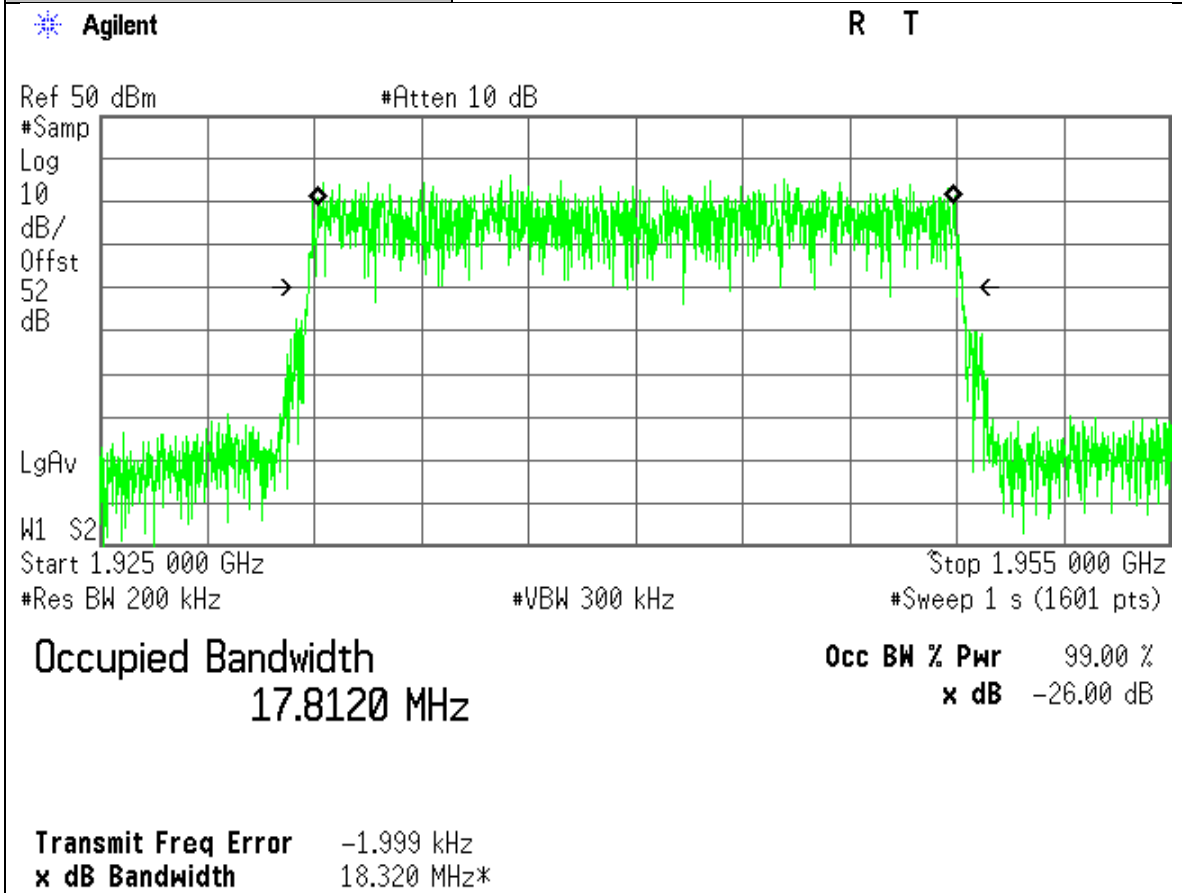

Project Number:	0048-130617-01
EUT:	AA190045
PART NO.:	RF151032
Tested By:	Wei Li
Temperature:	70°F
Humidity:	30%

Section:	Occupied Bandwidth: PCS Bands
Plot Name:	Downlink, Hi-Channel, LTE TM 31 Modulation
Configuration:	Input: Digital, Output: TX2 RF OUTPUT 5MHz Carrier Bandwidth

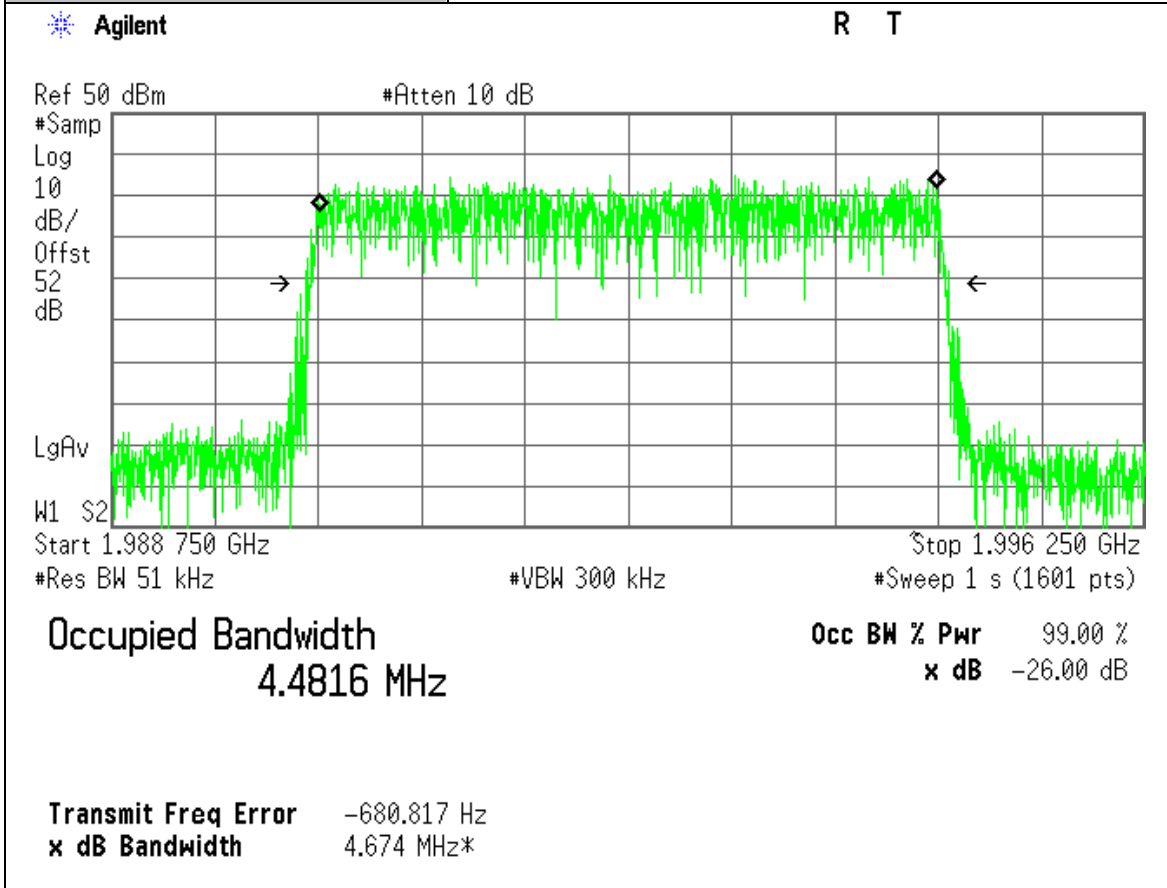

Project Number:	0048-130617-01
EUT:	AA190045
PART NO.:	RF151032
Tested By:	Wei Li
Temperature:	70°F
Humidity:	30%

Section:	Occupied Bandwidth: PCS Bands
Plot Name:	Downlink, Mid-Channel, LTE TM 31 Modulation
Configuration:	Input: Digital, Output: TX2 RF OUTPUT 5MHz Carrier Bandwidth

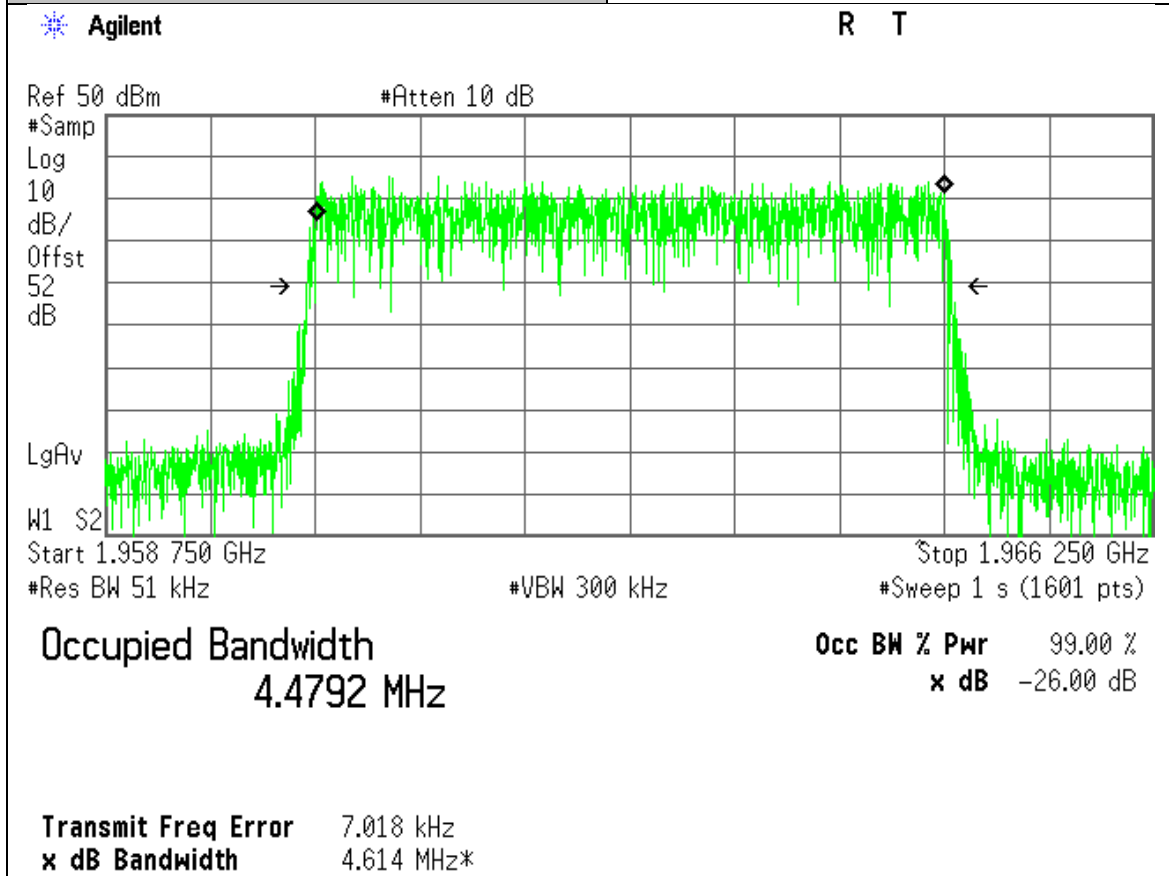

Project Number:	0048-130617-01
EUT:	AA190045
PART NO.:	RF151032
Tested By:	Wei Li
Temperature:	70°F
Humidity:	30%

Section:	Occupied Bandwidth: PCS Bands
Plot Name:	Downlink, Low-Channel, LTE TM 31 Modulation
Configuration:	Input: Digital, Output: TX2 RF OUTPUT 5MHz Carrier Bandwidth

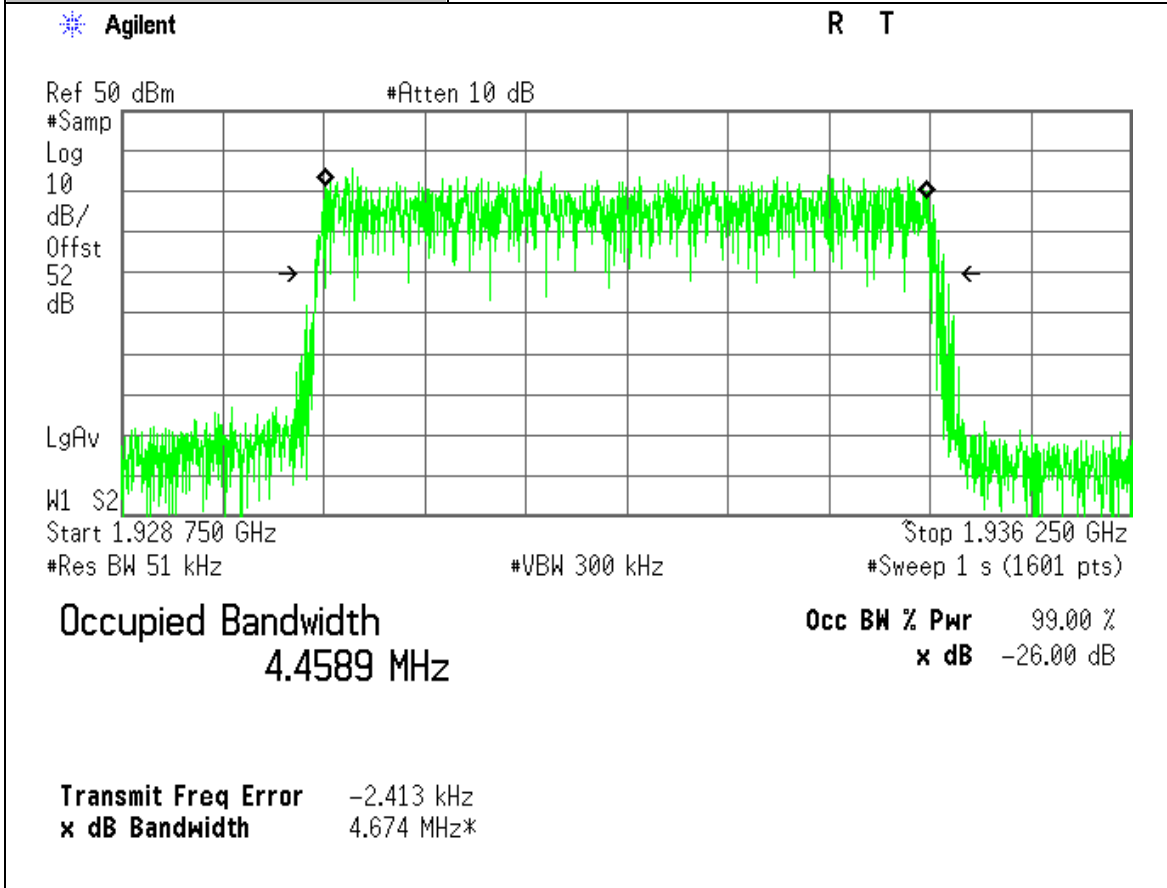

Project Number:	0048-130617-01
EUT:	AA190045
PART NO.:	RF151032
Tested By:	Wei Li
Temperature:	70°F
Humidity:	30%

Section:	Occupied Bandwidth: PCS Bands
Plot Name:	Downlink, Hi-Channel, LTE TM 31 Modulation
Configuration:	Input: Digital, Output: TX2 RF OUTPUT 10MHz Carrier Bandwidth

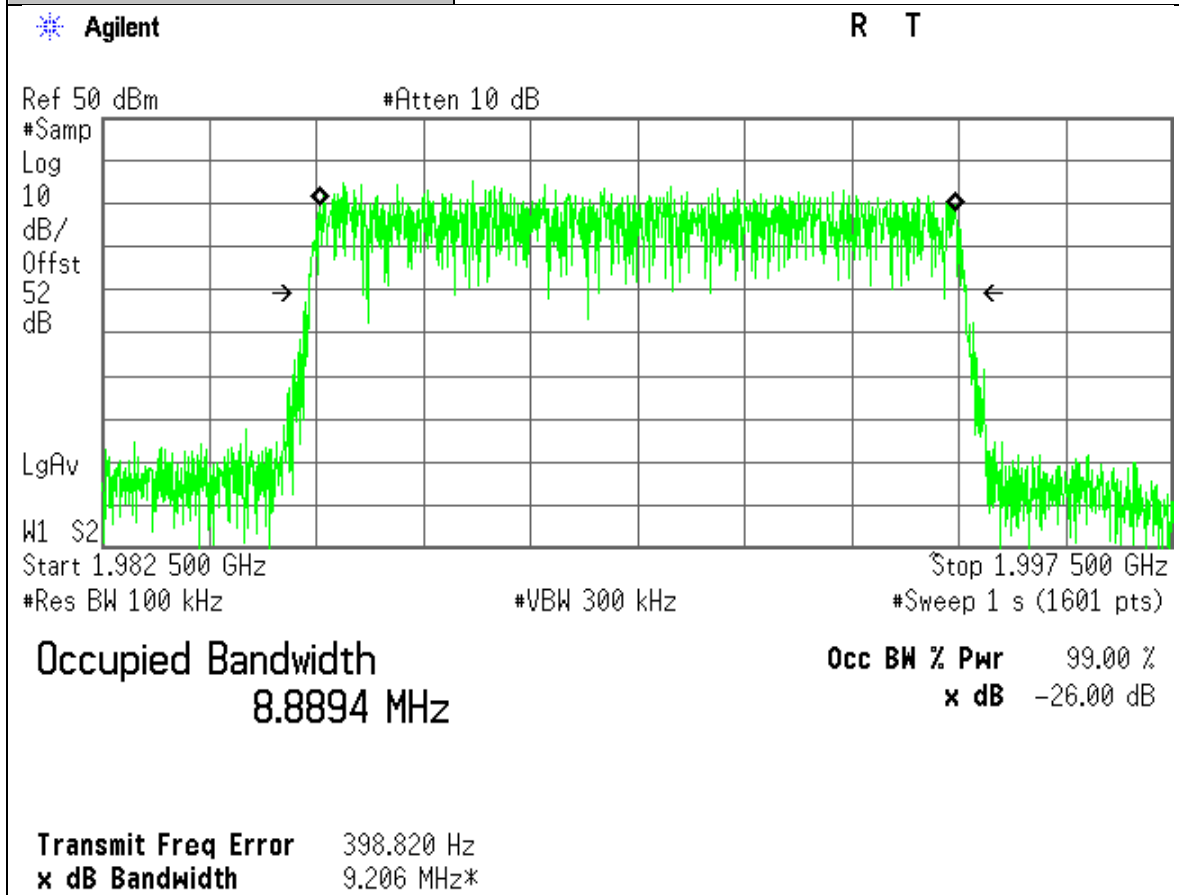

Project Number:	0048-130617-01
EUT:	AA190045
PART NO.:	RF151032
Tested By:	Wei Li
Temperature:	70°F
Humidity:	30%

Section:	Occupied Bandwidth: PCS Bands
Plot Name:	Downlink, Mid-Channel, LTE TM 31 Modulation
Configuration:	Input: Digital, Output: TX2 RF OUTPUT 10MHz Carrier Bandwidth

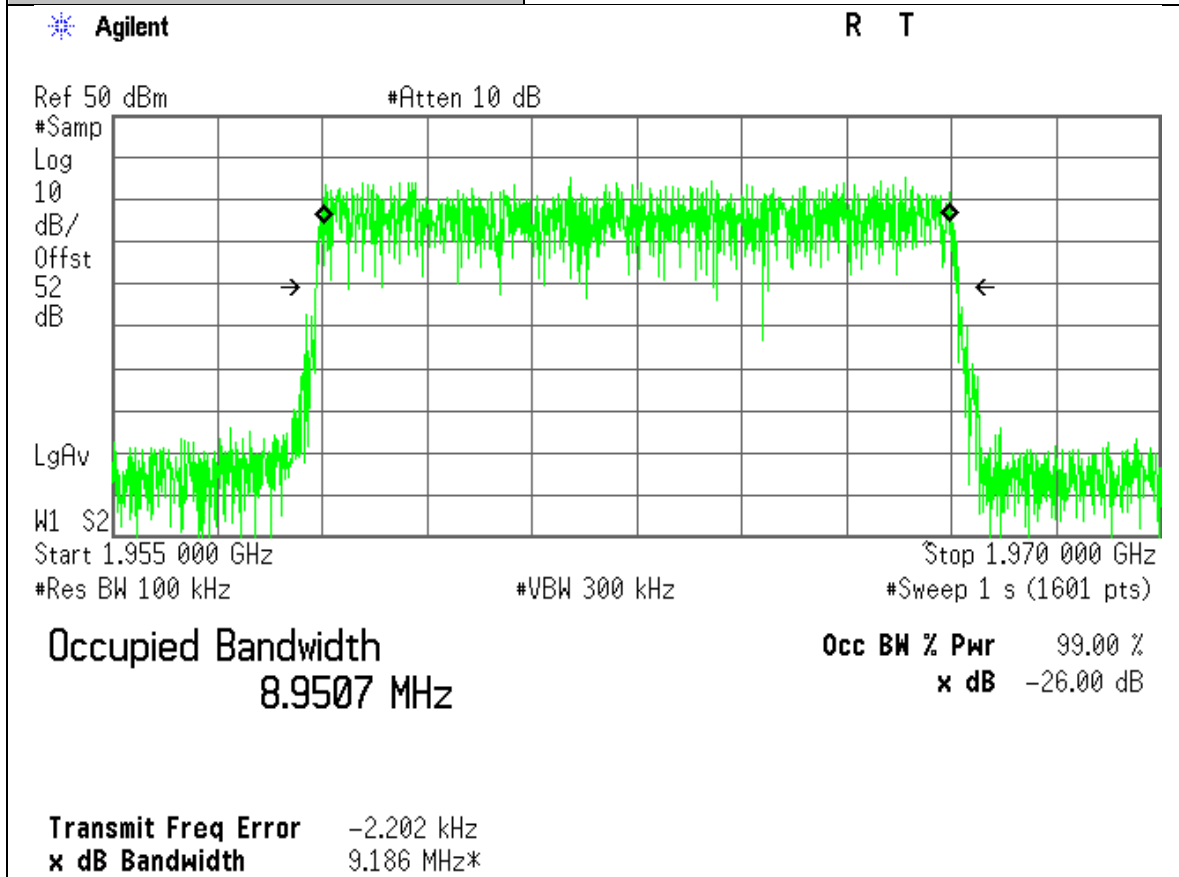

Project Number:	0048-130617-01
EUT:	AA190045
PART NO.:	RF151032
Tested By:	Wei Li
Temperature:	70°F
Humidity:	30%

Section:	Occupied Bandwidth: PCS Bands
Plot Name:	Downlink, Low-Channel, LTE TM 31 Modulation
Configuration:	Input: Digital, Output: TX2 RF OUTPUT 10MHz Carrier Bandwidth

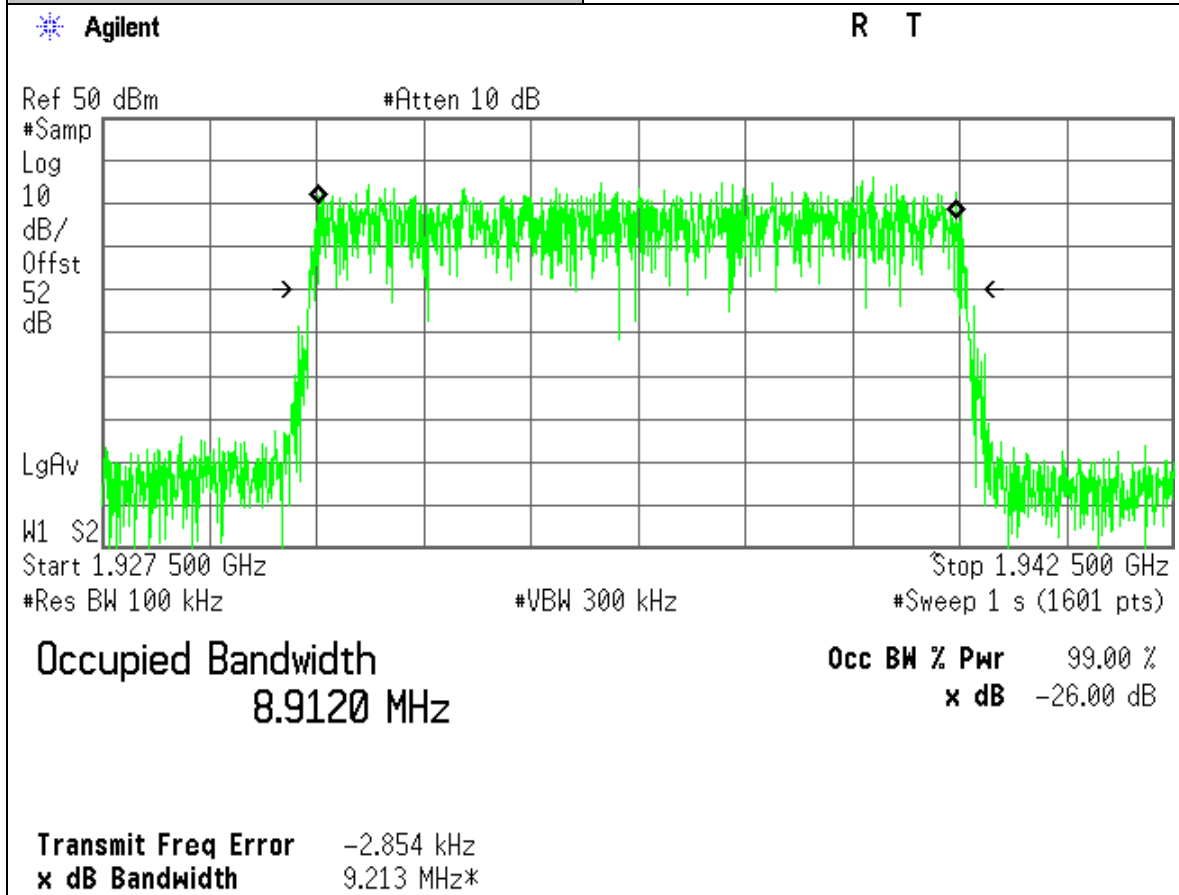

Project Number:	0048-130617-01
EUT:	AA190045
PART NO.:	RF151032
Tested By:	Wei Li
Temperature:	70°F
Humidity:	30%

Section:	Occupied Bandwidth: PCS Bands
Plot Name:	Downlink, Hi-Channel, LTE TM 31 Modulation
Configuration:	Input: Digital, Output: TX2 RF OUTPUT 20MHz Carrier Bandwidth

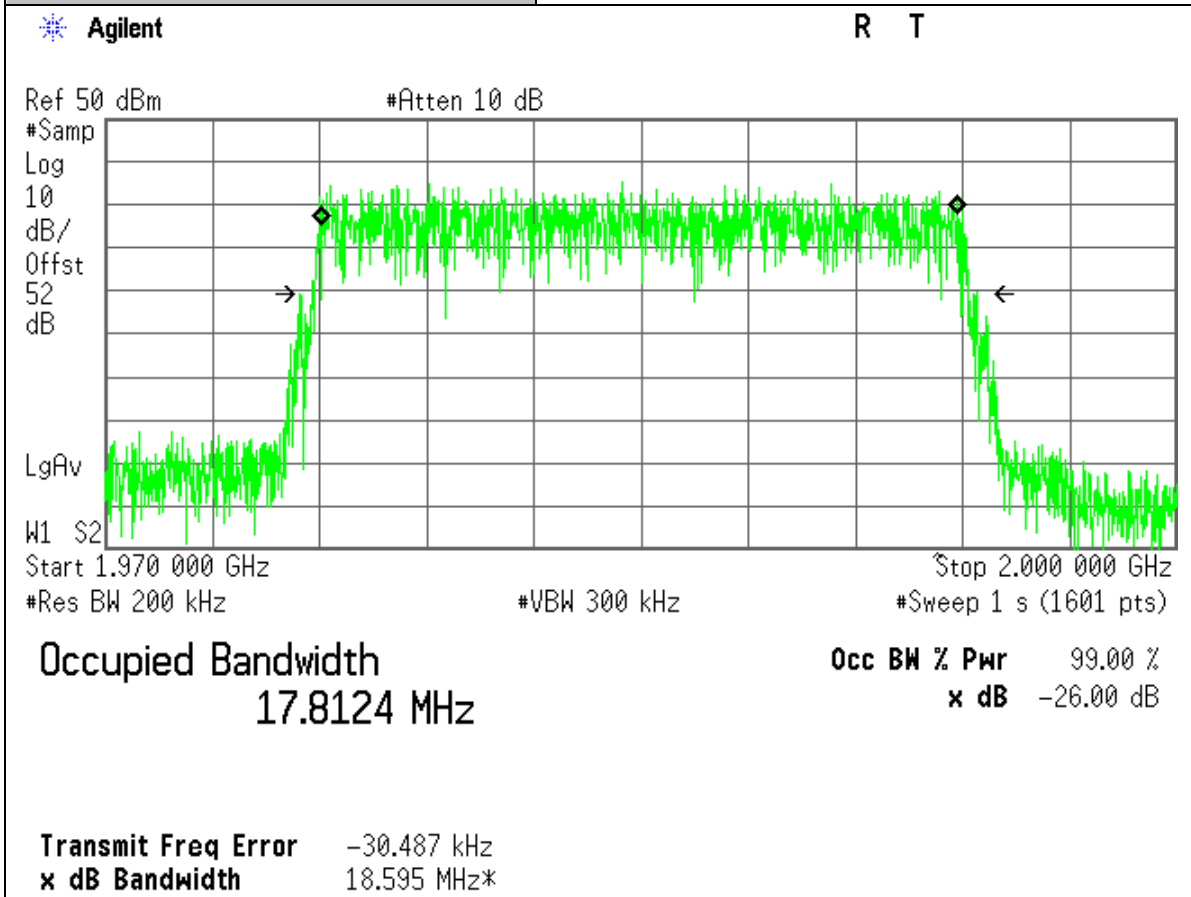

Project Number:	0048-130617-01
EUT:	AA190045
PART NO.:	RF151032
Tested By:	Wei Li
Temperature:	70°F
Humidity:	30%

Section:	Occupied Bandwidth: PCS Bands
Plot Name:	Downlink, Mid-Channel, LTE TM 31 Modulation
Configuration:	Input: Digital, Output: TX2 RF OUTPUT 20MHz Carrier Bandwidth

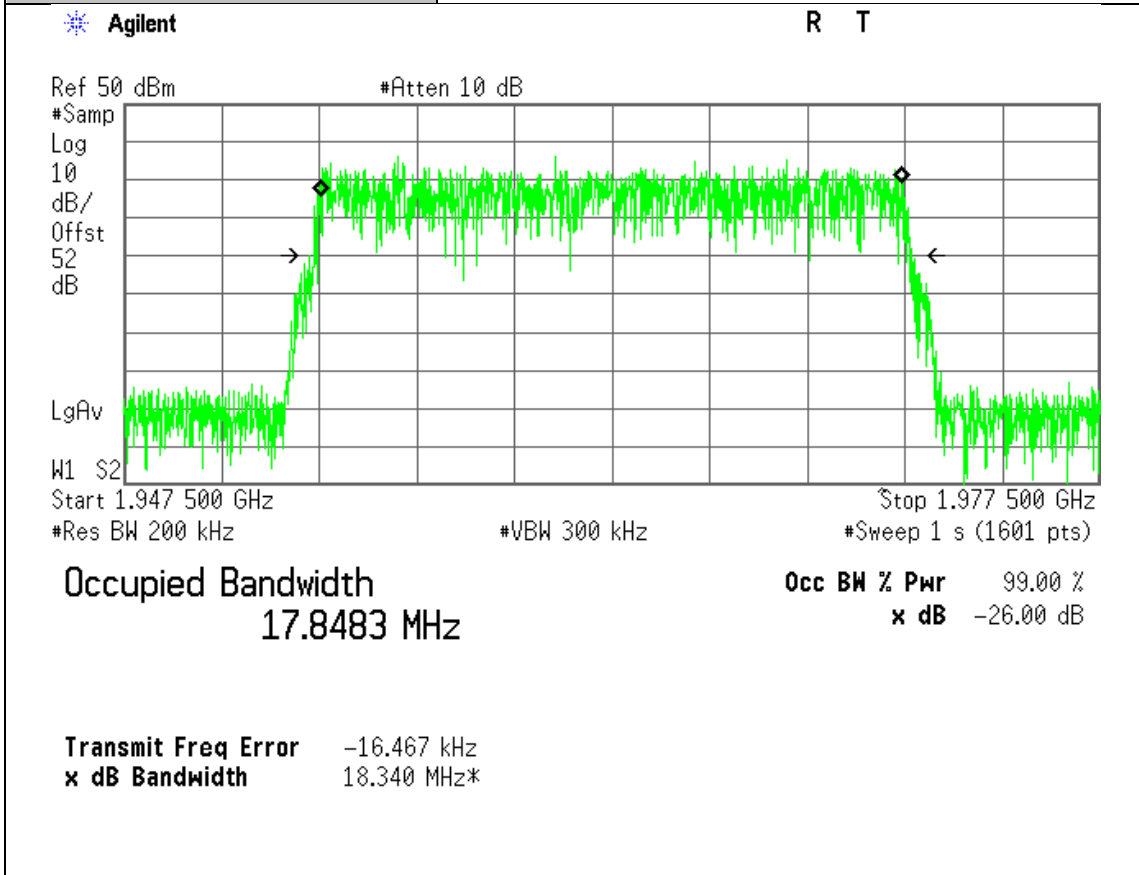

Project Number:	0048-130617-01
EUT:	AA190045
PART NO.:	RF151032
Tested By:	Wei Li
Temperature:	70°F
Humidity:	30%

Section:	Occupied Bandwidth: PCS Bands
Plot Name:	Downlink, Low-Channel, LTE TM 31 Modulation
Configuration:	Input: Digital, Output: TX2 RF OUTPUT 20MHz Carrier Bandwidth

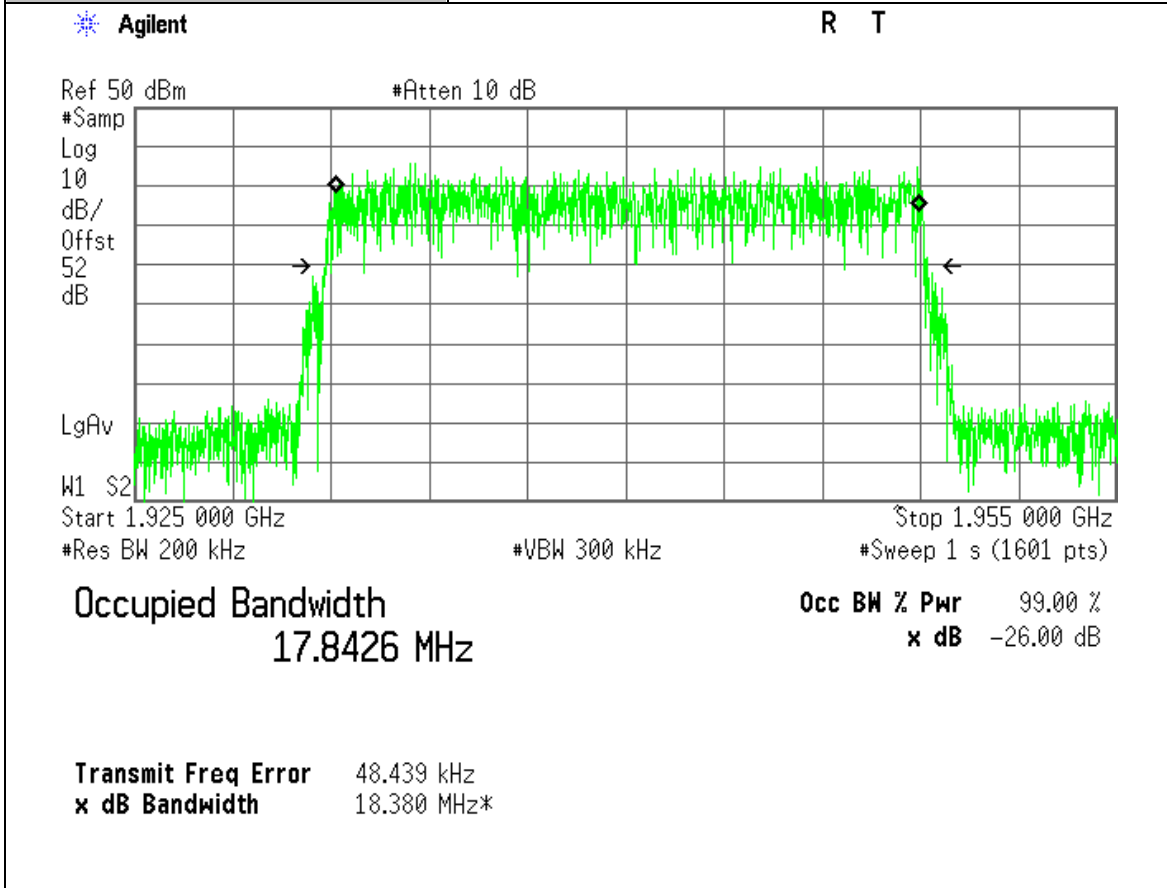

Project Number:	0048-130617-01
EUT:	AA190045
PART NO.:	RF151032
Tested By:	Wei Li
Temperature:	70°F
Humidity:	30%

Section:	Occupied Bandwidth: PCS Bands
Plot Name:	Downlink, Hi-Channel, LTE TM 32 Modulation
Configuration:	Input: Digital, Output: TX1 RF OUTPUT 5MHz Carrier Bandwidth

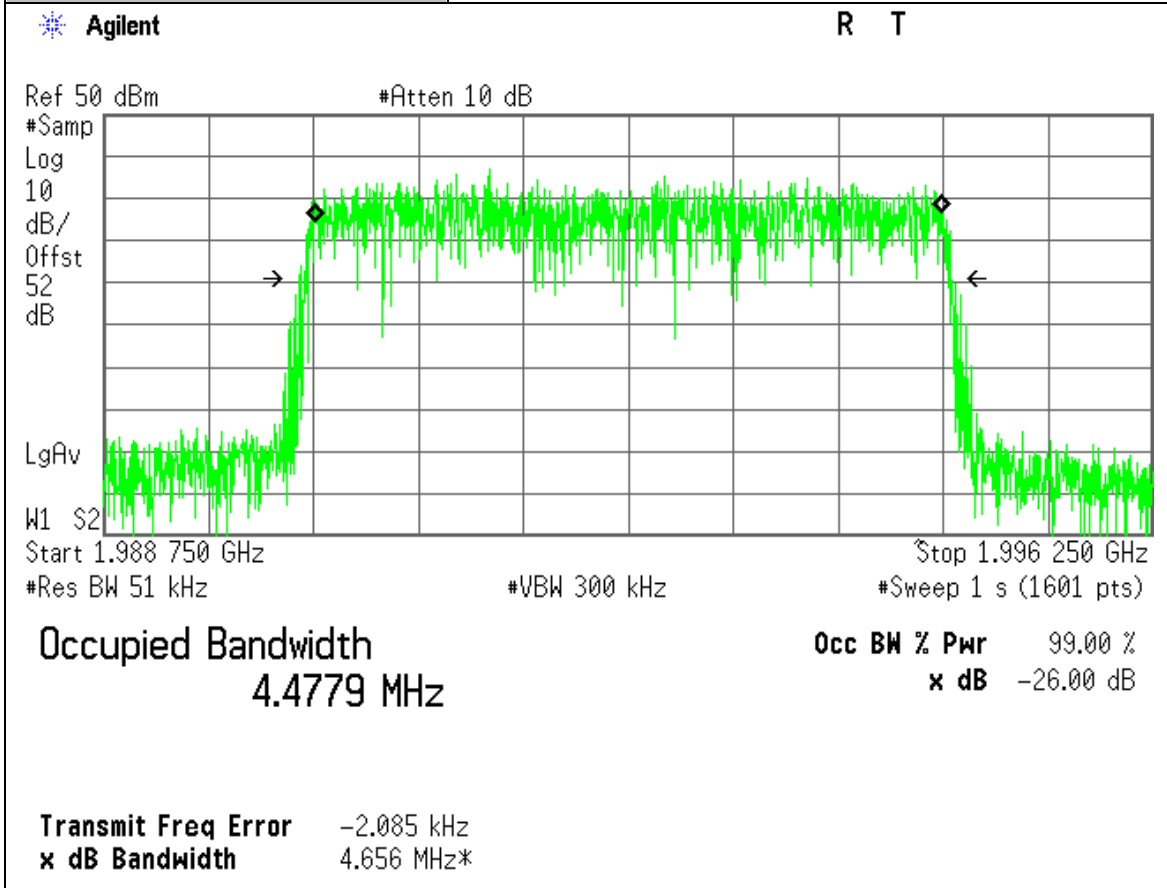

Project Number:	0048-130617-01
EUT:	AA190045
PART NO.:	RF151032
Tested By:	Wei Li
Temperature:	70°F
Humidity:	30%

Section:	Occupied Bandwidth: PCS Bands
Plot Name:	Downlink, Mid-Channel, LTE TM 32 Modulation
Configuration:	Input: Digital, Output: TX1 RF OUTPUT 5MHz Carrier Bandwidth

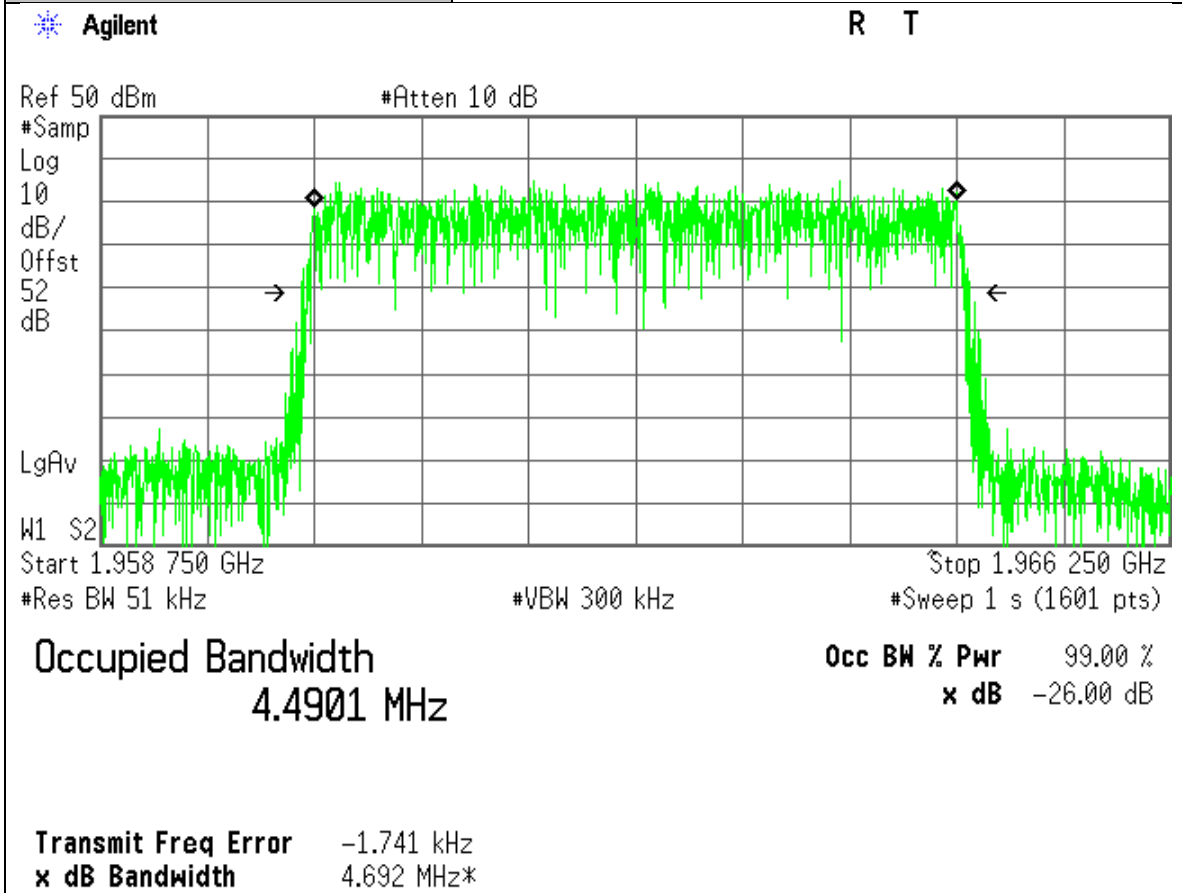

Project Number:	0048-130617-01
EUT:	AA190045
PART NO.:	RF151032
Tested By:	Wei Li
Temperature:	70°F
Humidity:	30%

Section:	Occupied Bandwidth: PCS Bands
Plot Name:	Downlink, Low-Channel, LTE TM 32 Modulation
Configuration:	Input: Digital, Output: TX1 RF OUTPUT 5MHz Carrier Bandwidth

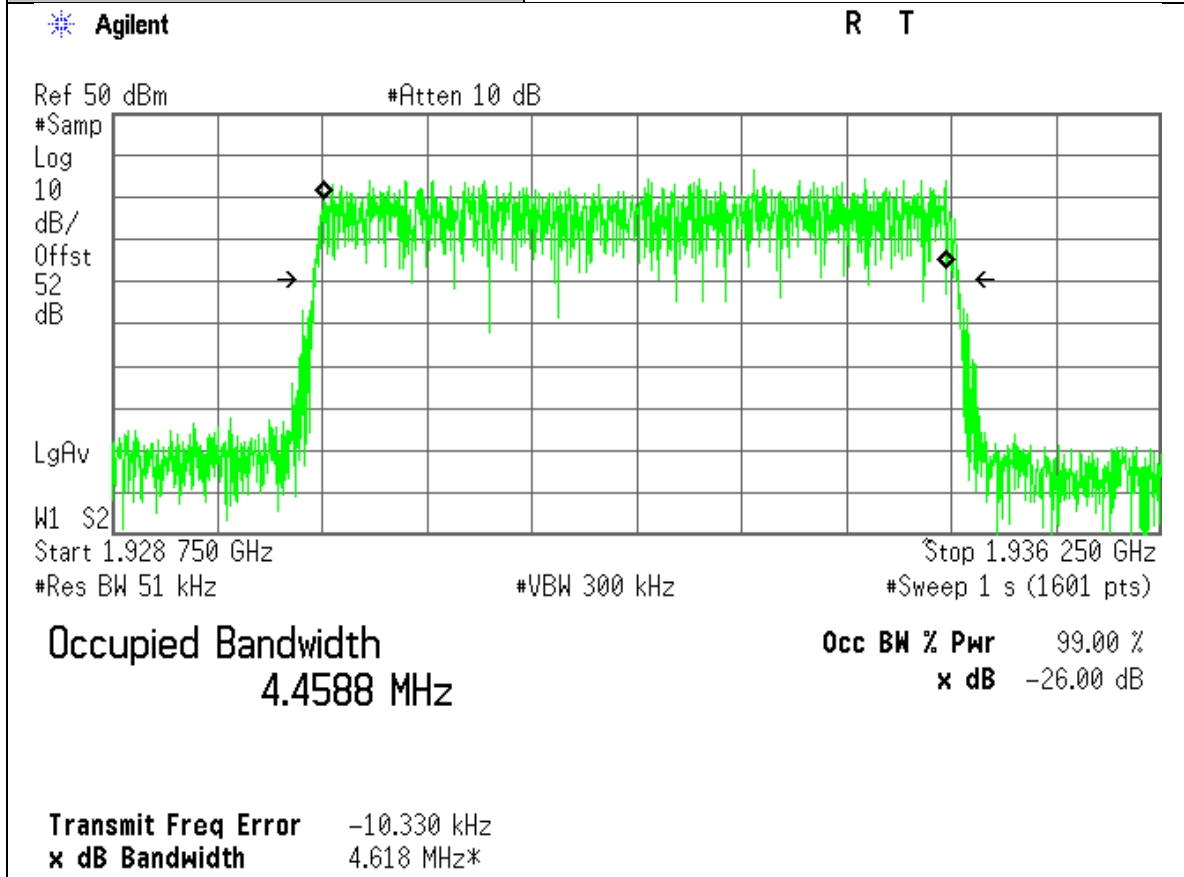

Project Number:	0048-130617-01
EUT:	AA190045
PART NO.:	RF151032
Tested By:	Wei Li
Temperature:	70°F
Humidity:	30%

Section:	Occupied Bandwidth: PCS Bands
Plot Name:	Downlink, Hi-Channel, LTE TM 32 Modulation
Configuration:	Input: Digital, Output: TX1 RF OUTPUT 10MHz Carrier Bandwidth

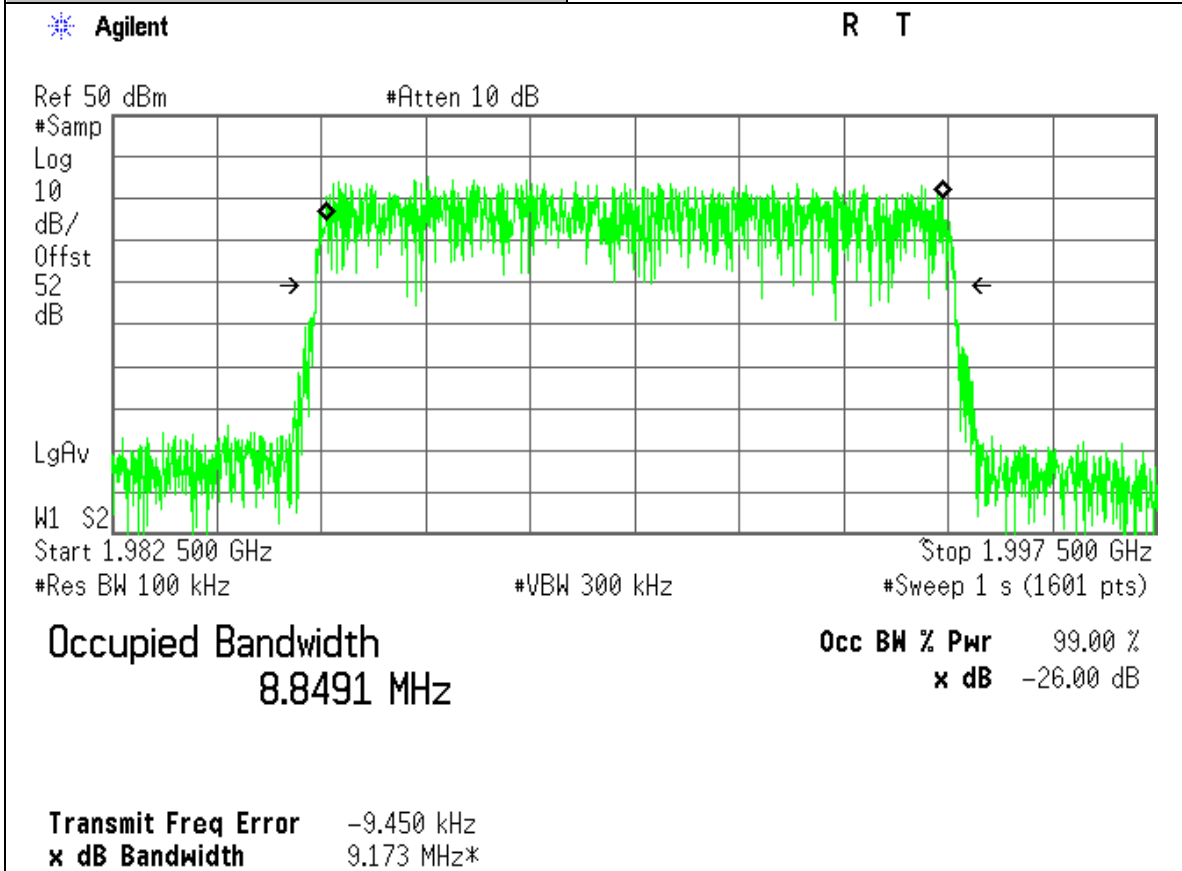

Project Number:	0048-130617-01
EUT:	AA190045
PART NO.:	RF151032
Tested By:	Wei Li
Temperature:	70°F
Humidity:	30%

Section:	Occupied Bandwidth: PCS Bands
Plot Name:	Downlink, Mid-Channel, LTE TM 32 Modulation
Configuration:	Input: Digital, Output: TX1 RF OUTPUT 10MHz Carrier Bandwidth

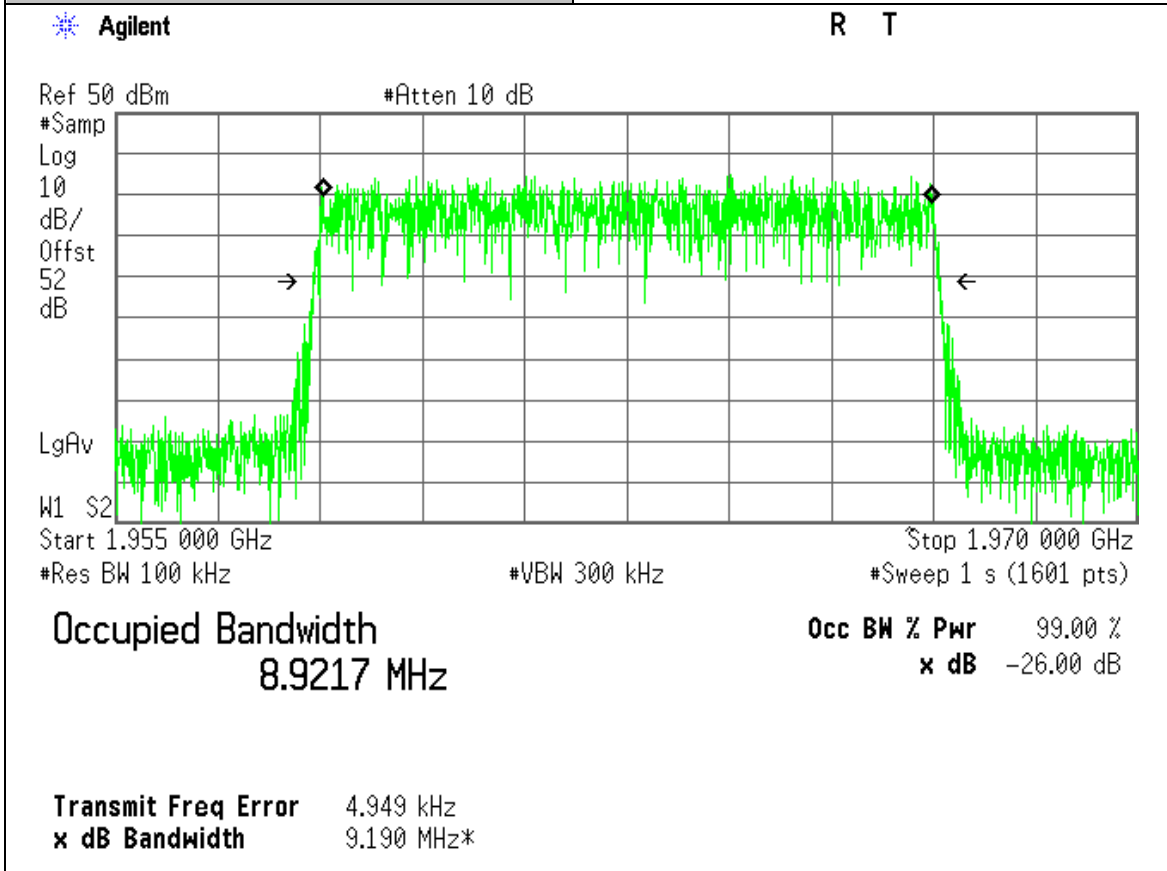

Project Number:	0048-130617-01
EUT:	AA190045
PART NO.:	RF151032
Tested By:	Wei Li
Temperature:	70°F
Humidity:	30%

Section:	Occupied Bandwidth: PCS Bands
Plot Name:	Downlink, Low-Channel, LTE TM 32 Modulation
Configuration:	Input: Digital, Output: TX1 RF OUTPUT 10MHz Carrier Bandwidth

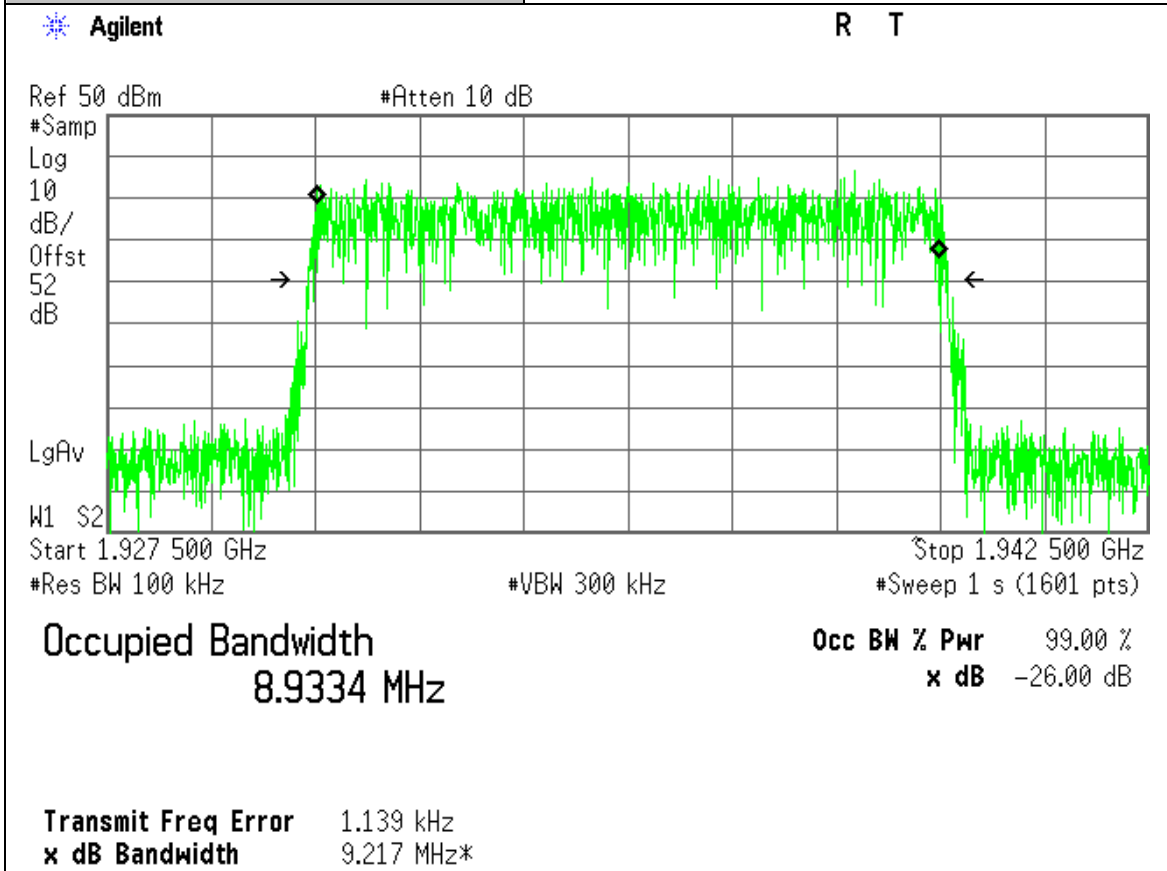

Project Number:	0048-130617-01
EUT:	AA190045
PART NO.:	RF151032
Tested By:	Wei Li
Temperature:	70°F
Humidity:	30%

Section:	Occupied Bandwidth: PCS Bands
Plot Name:	Downlink, Hi-Channel, LTE TM 32 Modulation
Configuration:	Input: Digital, Output: TX1 RF OUTPUT 20MHz Carrier Bandwidth

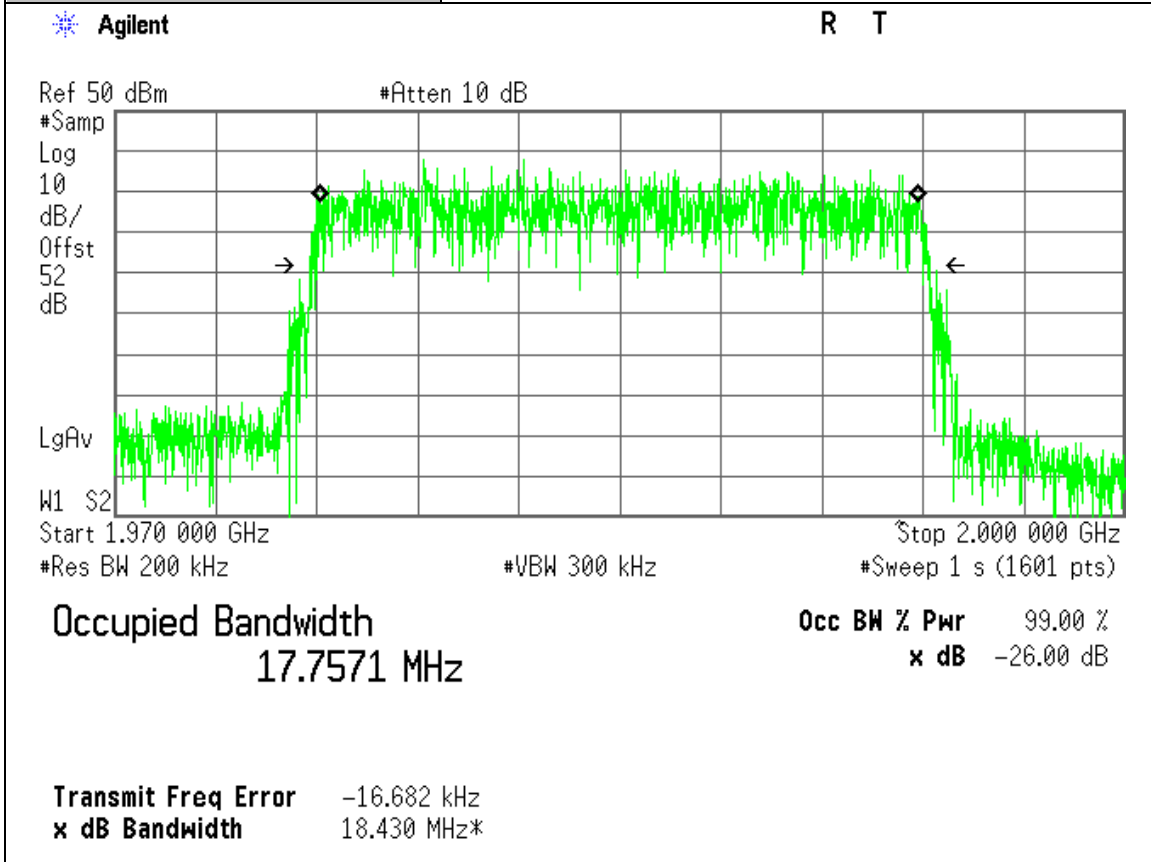

Project Number:	0048-130617-01
EUT:	AA190045
PART NO.:	RF151032
Tested By:	Wei Li
Temperature:	70°F
Humidity:	30%

Section:	Occupied Bandwidth: PCS Bands
Plot Name:	Downlink, Mid-Channel, LTE TM 32 Modulation
Configuration:	Input: Digital, Output: TX1 RF OUTPUT 20MHz Carrier Bandwidth

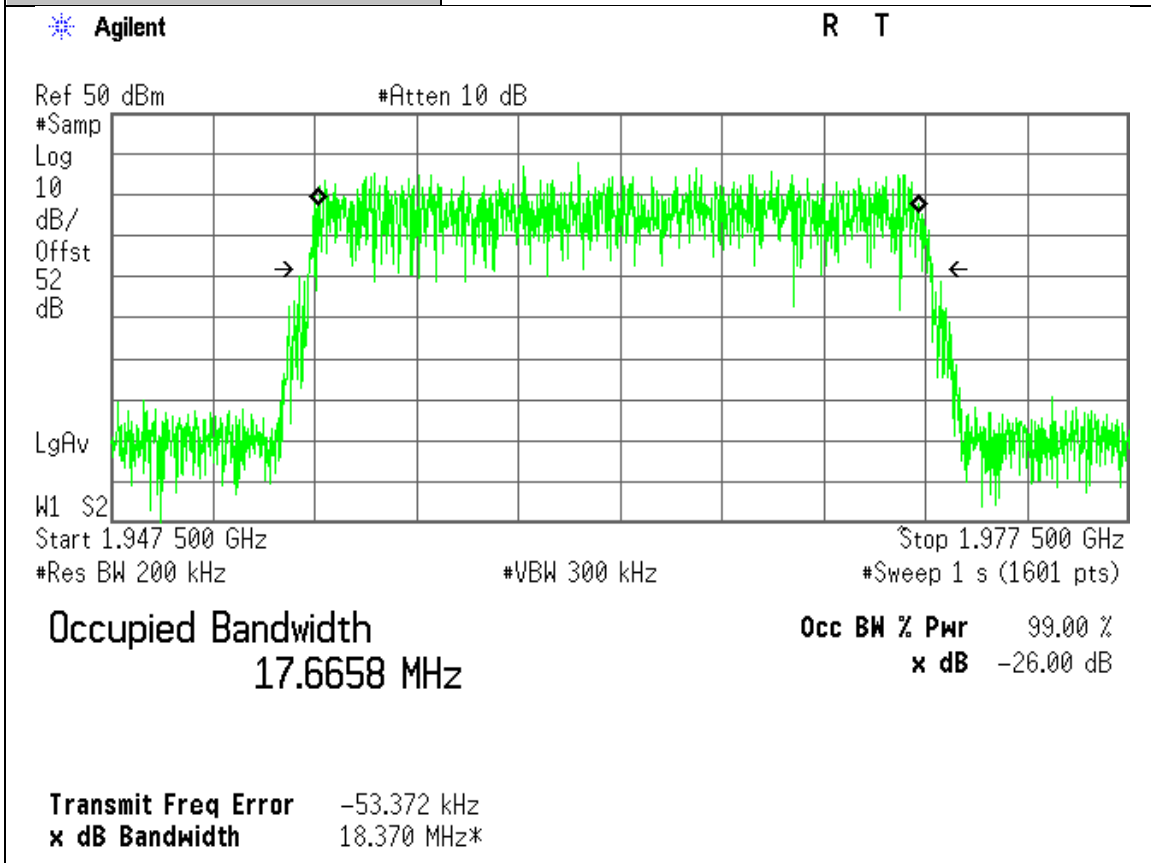

Project Number:	0048-130617-01
EUT:	AA190045
PART NO.:	RF151032
Tested By:	Wei Li
Temperature:	70°F
Humidity:	30%

Section:	Occupied Bandwidth: PCS Bands
Plot Name:	Downlink, Low-Channel, LTE TM 32 Modulation
Configuration:	Input: Digital, Output: TX1 RF OUTPUT 20MHz Carrier Bandwidth

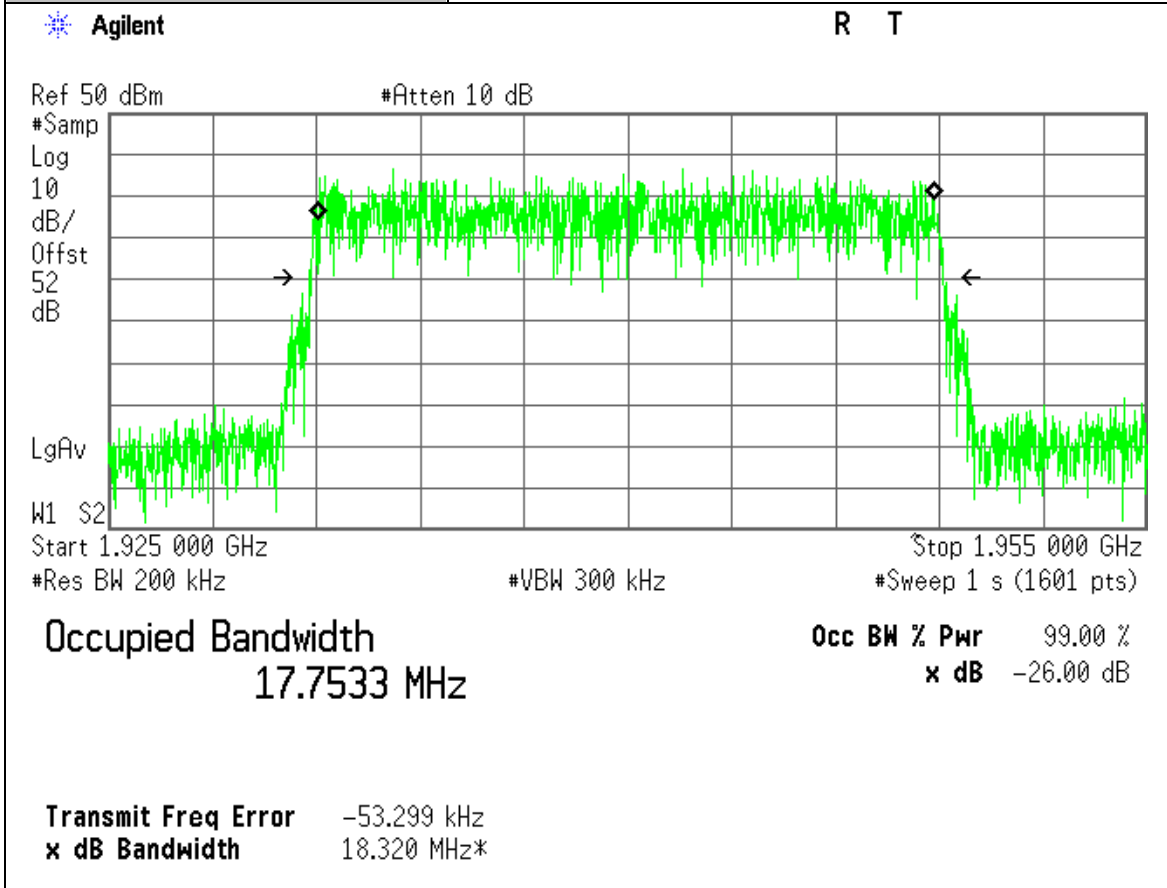

Project Number:	0048-130617-01
EUT:	AA190045
PART NO.:	RF151032
Tested By:	Wei Li
Temperature:	70°F
Humidity:	30%

Section:	Occupied Bandwidth: PCS Bands
Plot Name:	Downlink, Hi-Channel, LTE TM 32 Modulation
Configuration:	Input: Digital, Output: TX2 RF OUTPUT 5MHz Carrier Bandwidth

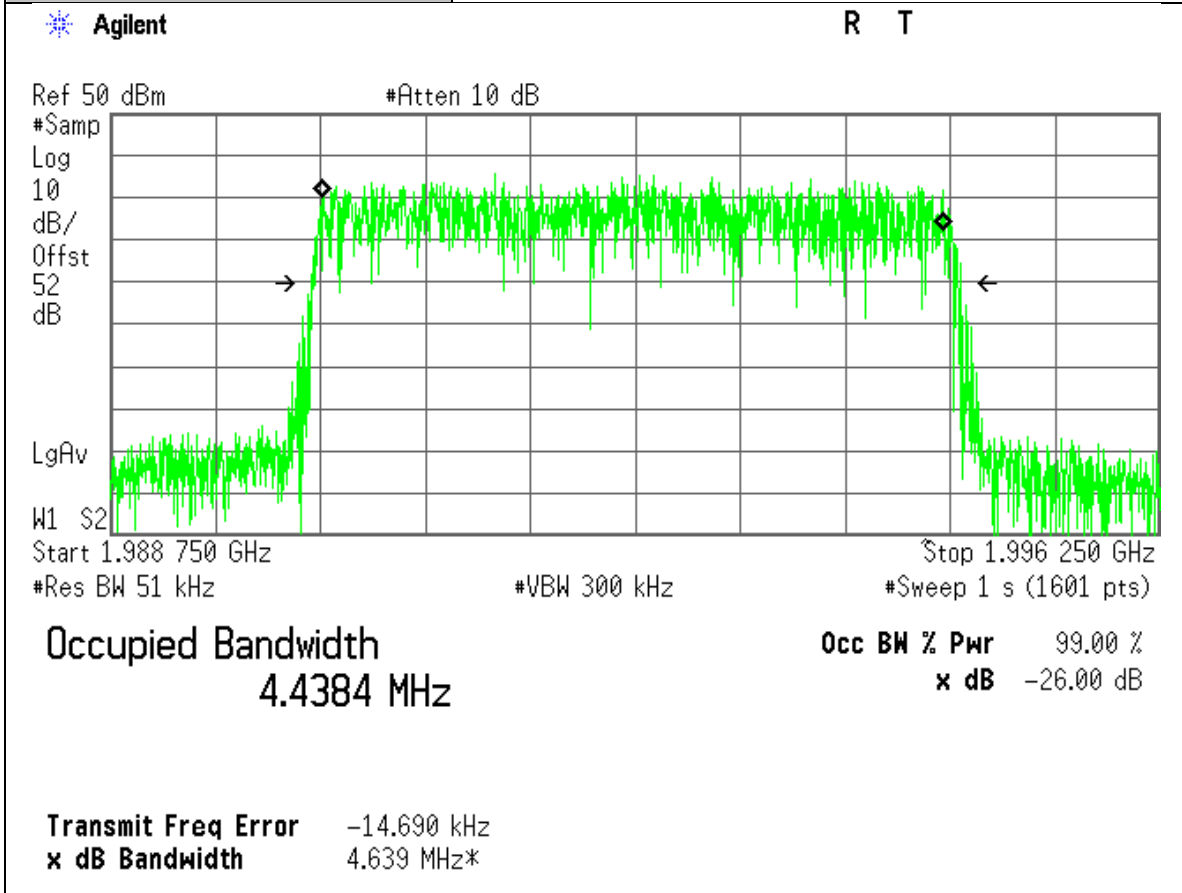

Project Number:	0048-130617-01
EUT:	AA190045
PART NO.:	RF151032
Tested By:	Wei Li
Temperature:	70°F
Humidity:	30%

Section:	Occupied Bandwidth: PCS Bands
Plot Name:	Downlink, Mid-Channel, LTE TM 32 Modulation
Configuration:	Input: Digital, Output: TX2 RF OUTPUT 5MHz Carrier Bandwidth

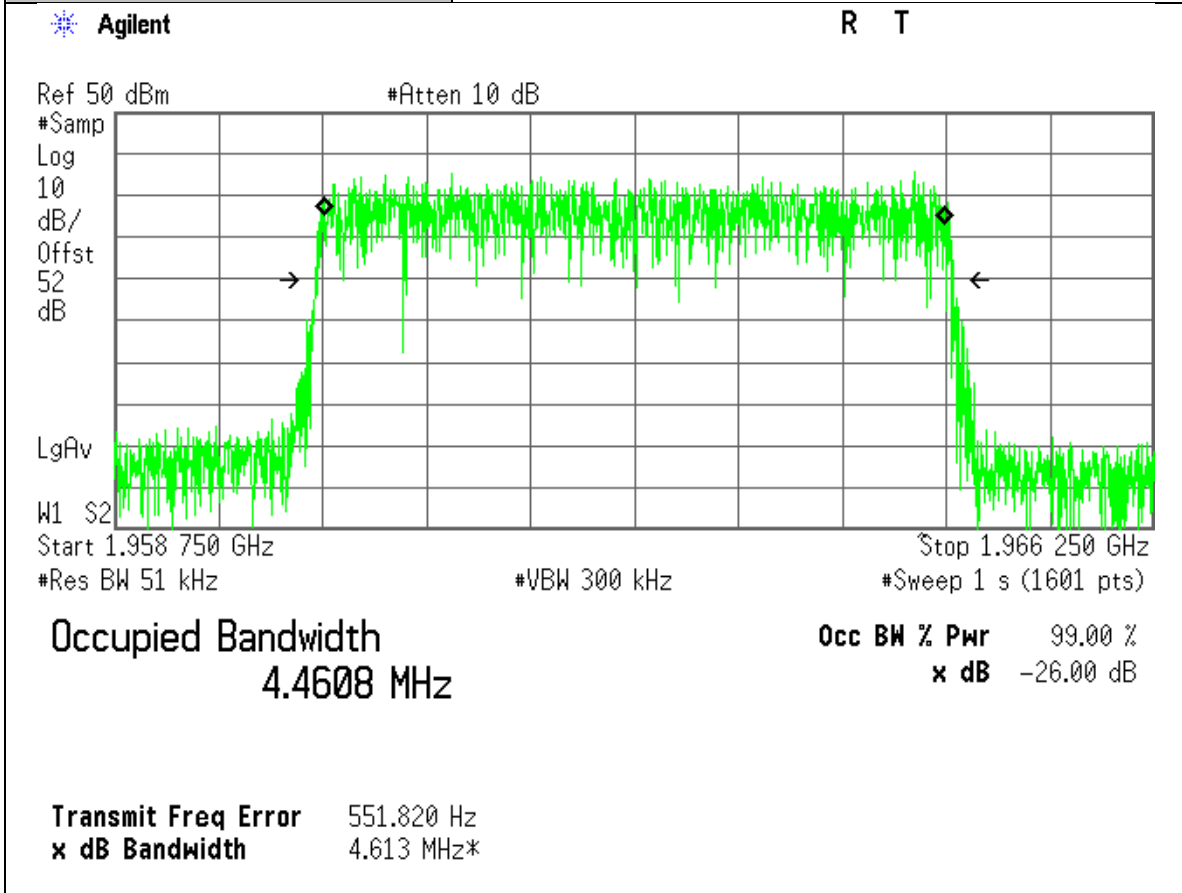

Project Number:	0048-130617-01
EUT:	AA190045
PART NO.:	RF151032
Tested By:	Wei Li
Temperature:	70°F
Humidity:	30%

Section:	Occupied Bandwidth: PCS Bands
Plot Name:	Downlink, Low-Channel, LTE TM 32 Modulation
Configuration:	Input: Digital, Output: TX2 RF OUTPUT 5MHz Carrier Bandwidth

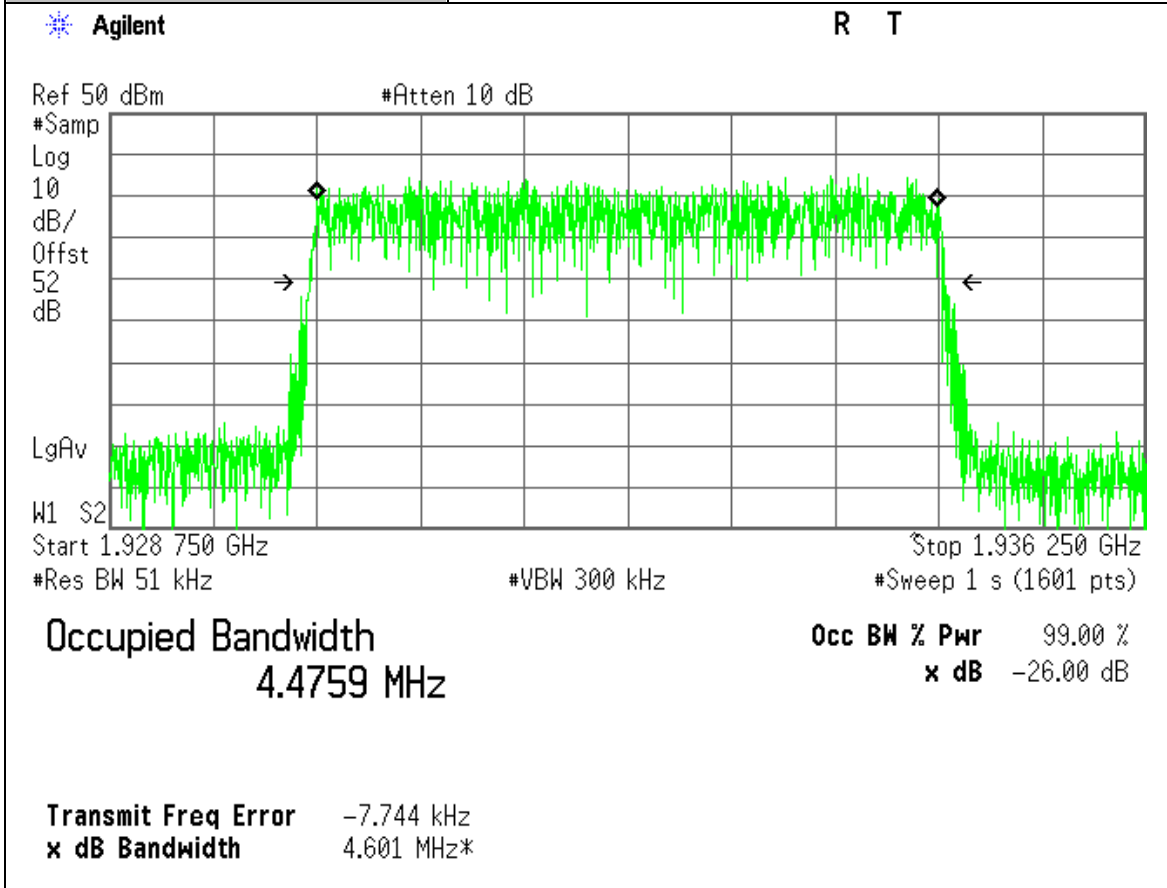

Project Number:	0048-130617-01
EUT:	AA190045
PART NO.:	RF151032
Tested By:	Wei Li
Temperature:	70°F
Humidity:	30%

Section:	Occupied Bandwidth: PCS Bands
Plot Name:	Downlink, Hi-Channel, LTE TM 32 Modulation
Configuration:	Input: Digital, Output: TX2 RF OUTPUT 10MHz Carrier Bandwidth

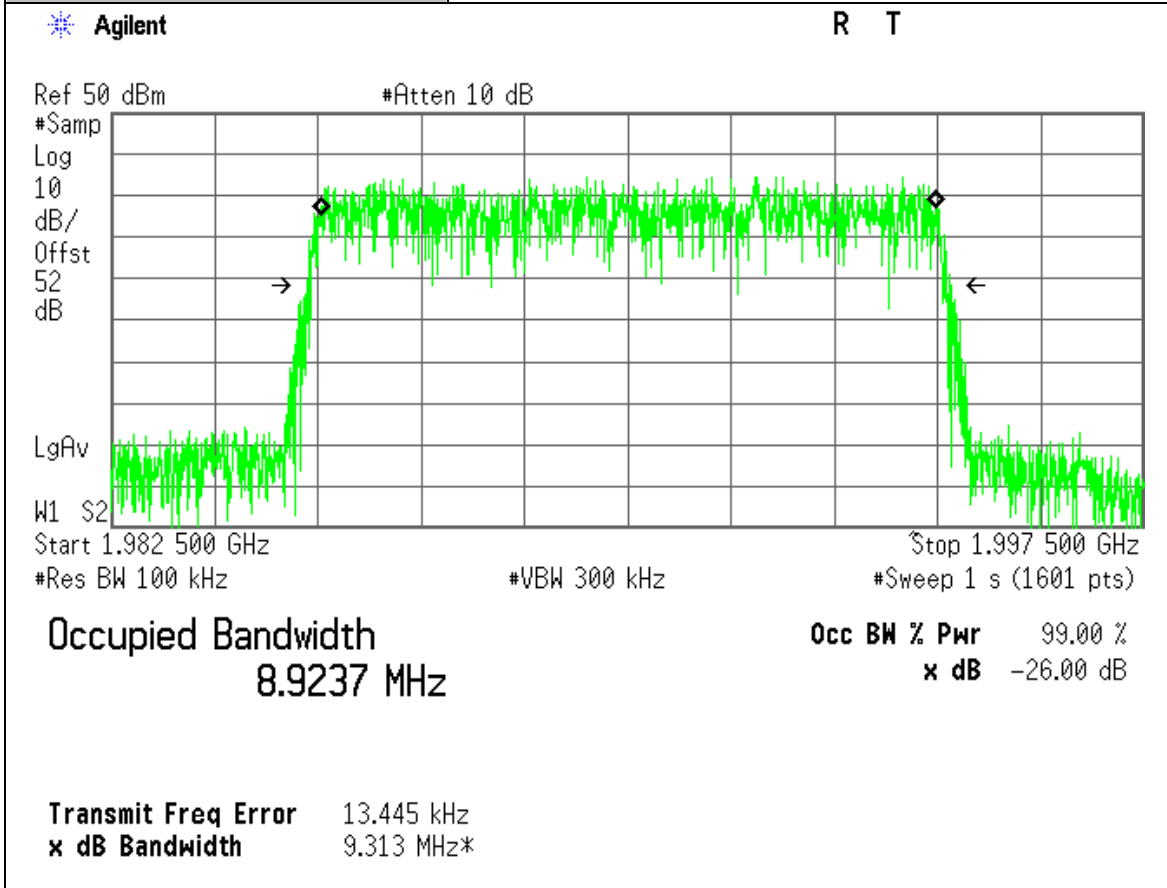

Project Number:	0048-130617-01
EUT:	AA190045
PART NO.:	RF151032
Tested By:	Wei Li
Temperature:	70°F
Humidity:	30%

Section:	Occupied Bandwidth: PCS Bands
Plot Name:	Downlink, Mid-Channel, LTE TM 32 Modulation
Configuration:	Input: Digital, Output: TX2 RF OUTPUT 10MHz Carrier Bandwidth

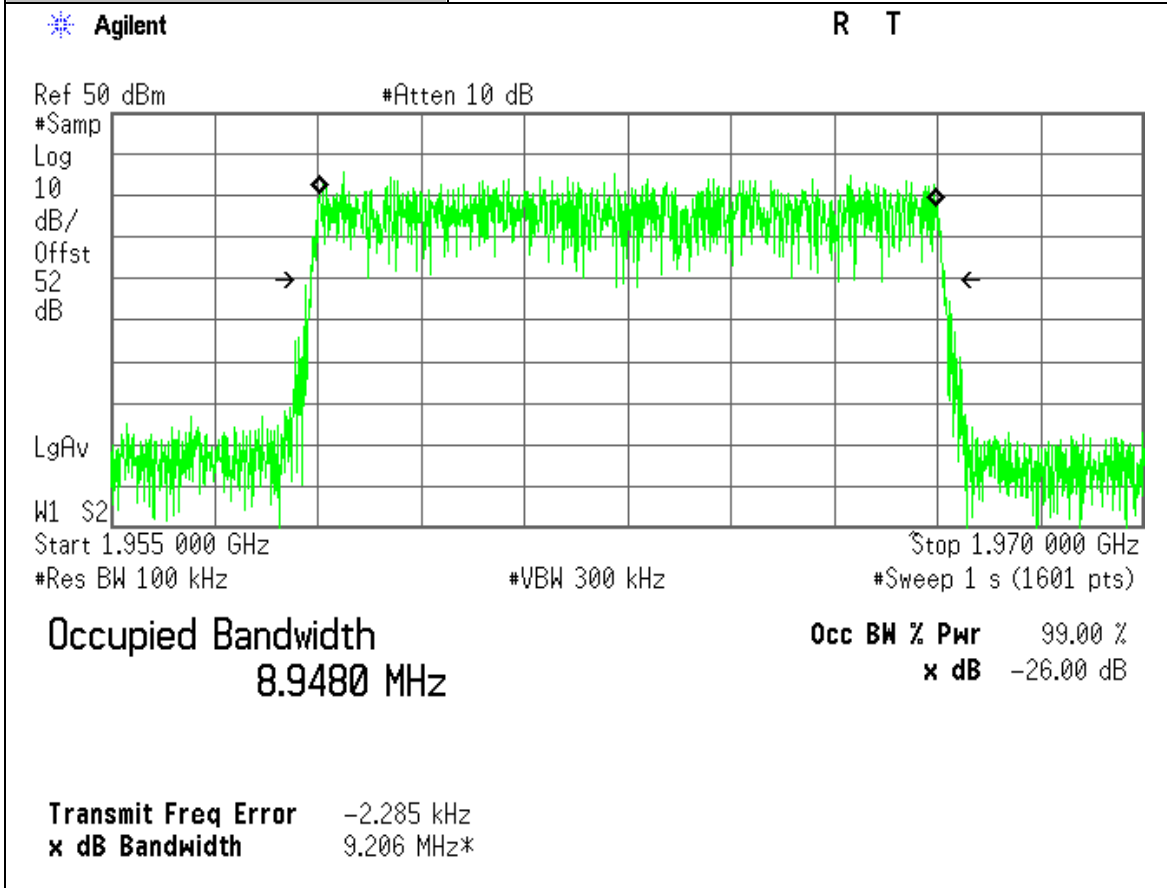

Project Number:	0048-130617-01
EUT:	AA190045
PART NO.:	RF151032
Tested By:	Wei Li
Temperature:	70°F
Humidity:	30%

Section:	Occupied Bandwidth: PCS Bands
Plot Name:	Downlink, Low-Channel, LTE TM 32 Modulation
Configuration:	Input: Digital, Output: TX2 RF OUTPUT 10MHz Carrier Bandwidth

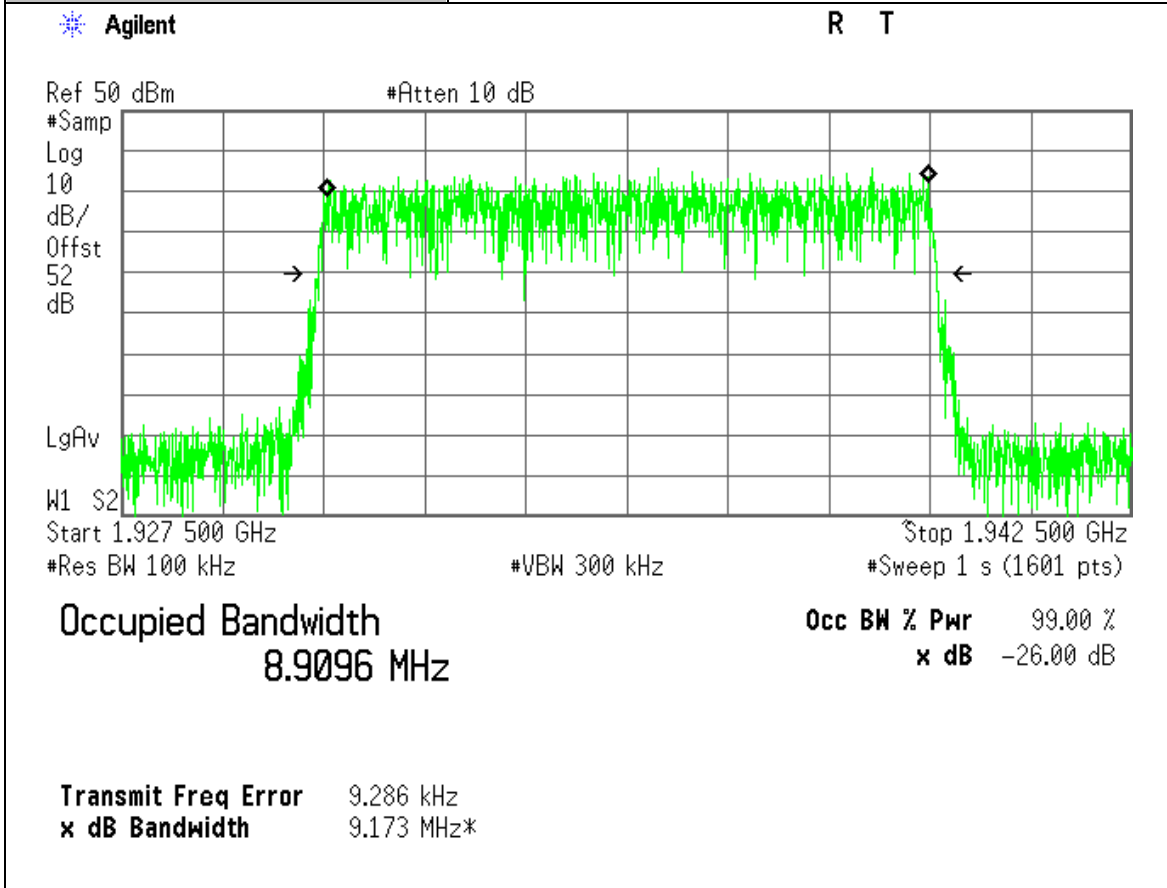

Project Number:	0048-130617-01
EUT:	AA190045
PART NO.:	RF151032
Tested By:	Wei Li
Temperature:	70°F
Humidity:	30%

Section:	Occupied Bandwidth: PCS Bands
Plot Name:	Downlink, Hi-Channel, LTE TM 32 Modulation
Configuration:	Input: Digital, Output: TX2 RF OUTPUT 20MHz Carrier Bandwidth

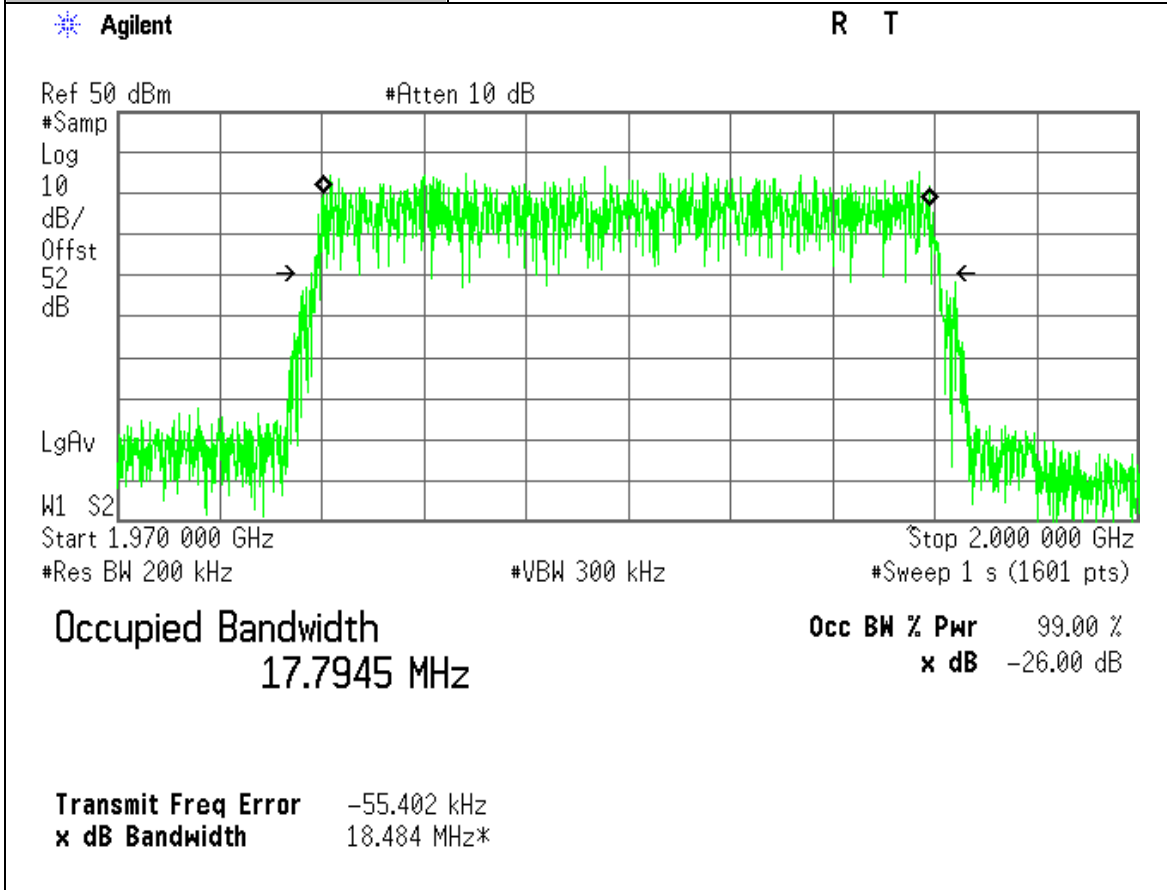

Project Number:	0048-130617-01
EUT:	AA190045
PART NO.:	RF151032
Tested By:	Wei Li
Temperature:	70°F
Humidity:	30%

Section:	Occupied Bandwidth: PCS Bands
Plot Name:	Downlink, Mid-Channel, LTE TM 32 Modulation
Configuration:	Input: Digital, Output: TX2 RF OUTPUT 20MHz Carrier Bandwidth

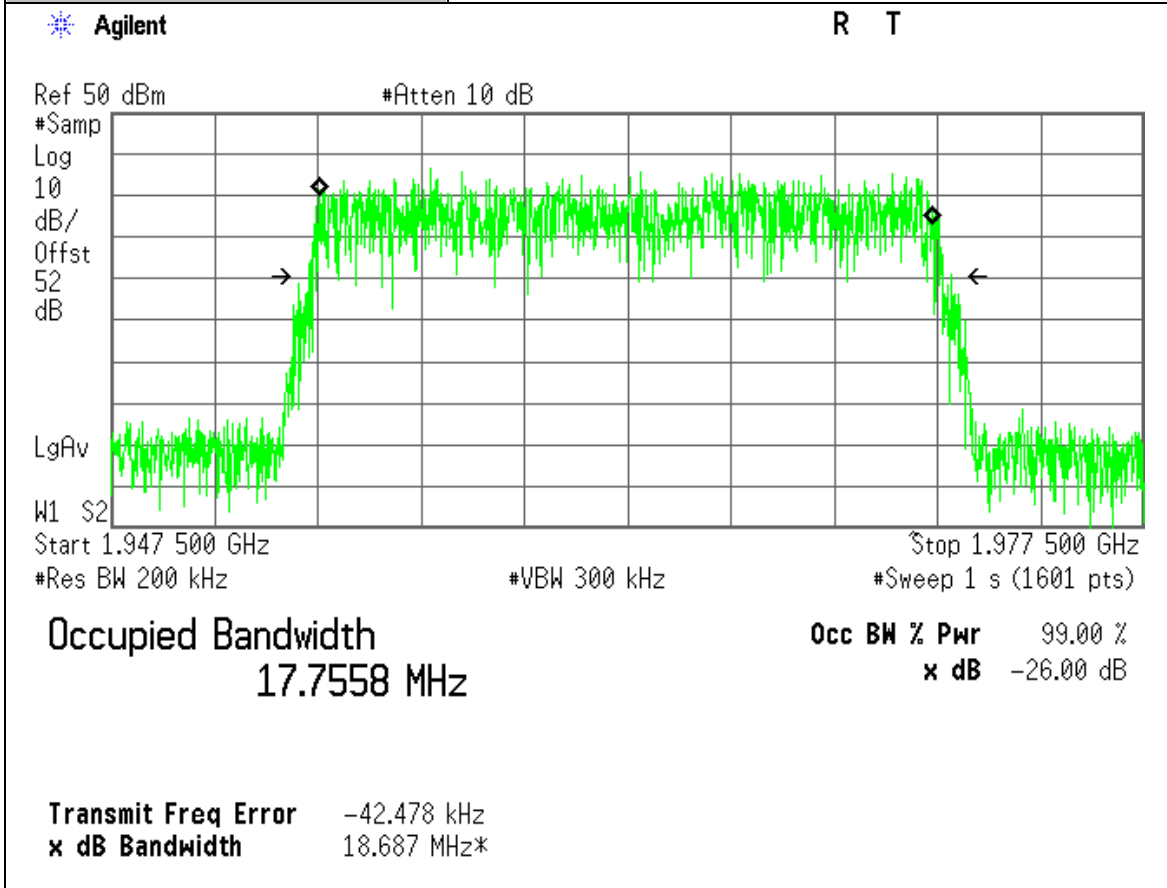

Project Number:	0048-130617-01
EUT:	AA190045
PART NO.:	RF151032
Tested By:	Wei Li
Temperature:	70°F
Humidity:	30%

Section:	Occupied Bandwidth: PCS Bands
Plot Name:	Downlink, Low-Channel, LTE TM 32 Modulation
Configuration:	Input: Digital, Output: TX2 RF OUTPUT 20MHz Carrier Bandwidth

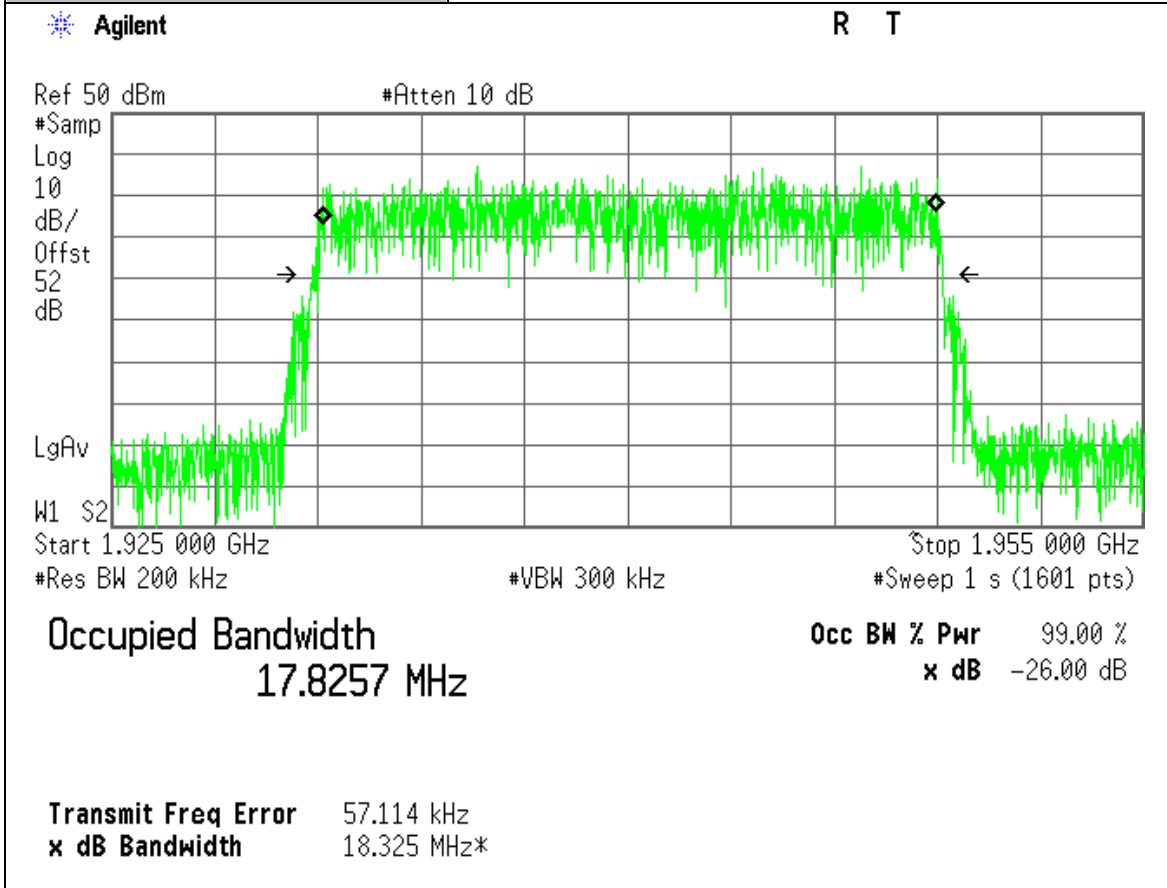

Section 5. Spurious Emissions at Antenna Terminals

Name of Test:	<i>Spurious Emissions at Antenna Terminals</i>	Test Standard:	<i>24.238(a)</i>
Tested By:	WEI LI	Test Date:	06/17/2013-06/25/2013

Minimum

Standard: Para. No. 24.238(a). The magnitude of each spurious and harmonic emission that can be detected when the equipment is operated under conditions specified in the instruction manual and/or alignment procedure, shall not less than $43+10 \log$ (mean output power in watts) dBc below the mean power output outside a licensee's frequency block (-13dBm).

Method of Measurement: Spectrum Analyzer Settings:
 RBW: 1MHz (100 kHz RBW for bandedge measurement)
 VBW: \geq RBW
 Start Frequency: 9KHz or Lowest Clock Frequency
 Stop Frequency: 20GHz (PCS)
 Sweep: Auto or greater.
 Using in-band filter if needed.
 For Inter-modulation measurement: 2 carriers RF signals set as inputs per Frequency Table on page 7. The frequencies of RF signals shall be within the unit's operating band The level of both RF input signals shall be increased, until the maximum rated output power per channel, as declared by the manufacturer, is reached.

Test Result:

Complies

Test Data:

Attached Plots

Project Number:	0048-130617-01
EUT:	AA190045
PARTS NO.:	RF151032
Tested By:	Wei Li
Temperature:	70°F
Humidity:	30%

Section:	Spurious Emissions at RF Output Port:
Plot Name:	Downlink, Inter-modulation
Configuration:	Input: Digital; Output: TX1 RF Output TM 11 5MHz Carrier BW, Low freq

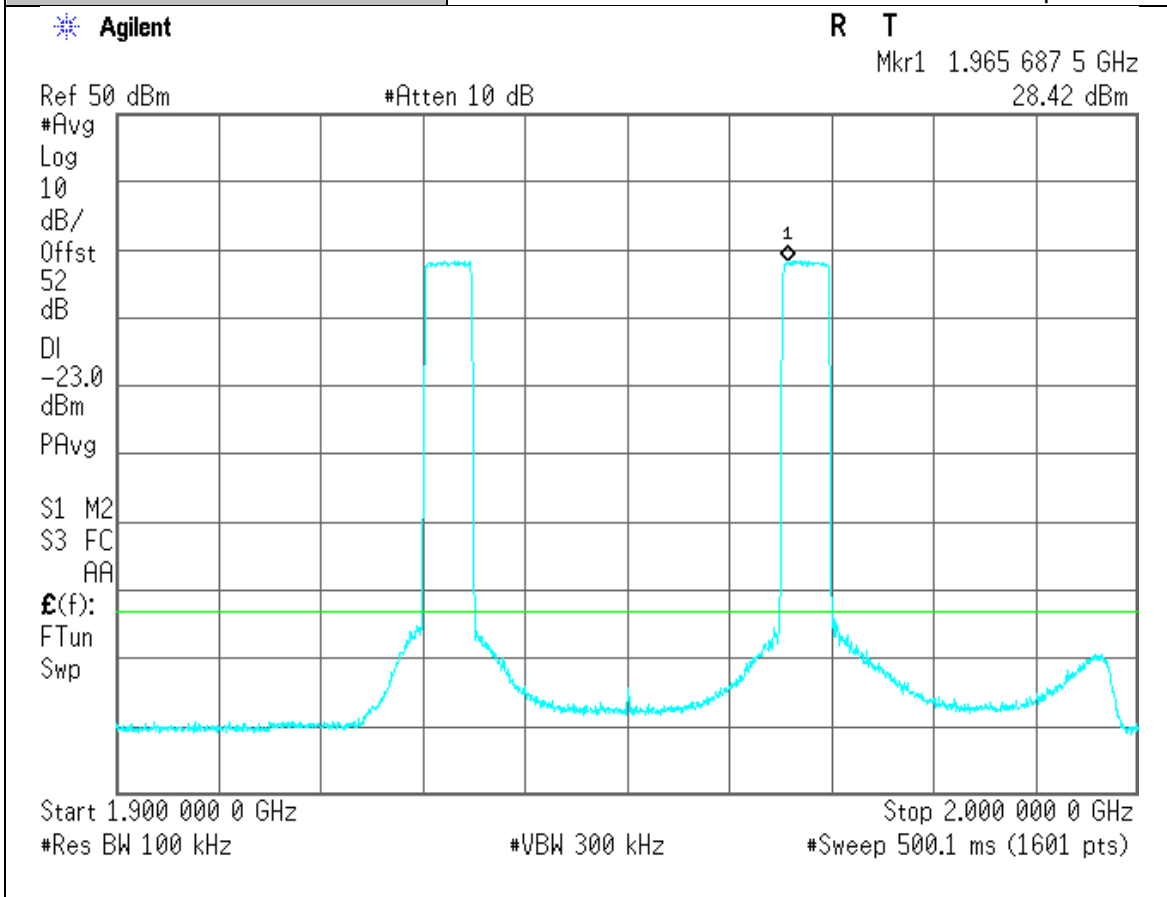

Project Number:	0048-130617-01
EUT:	AA190045
PARTS NO.:	RF151032
Tested By:	Wei Li
Temperature:	70°F
Humidity:	30%

Section:	Spurious Emissions at RF Output Port:
Plot Name:	Downlink, Inter-modulation
Configuration:	Input: Digital; Output: TX1 RF Output TM 11 5MHz Carrier BW, Mid freq

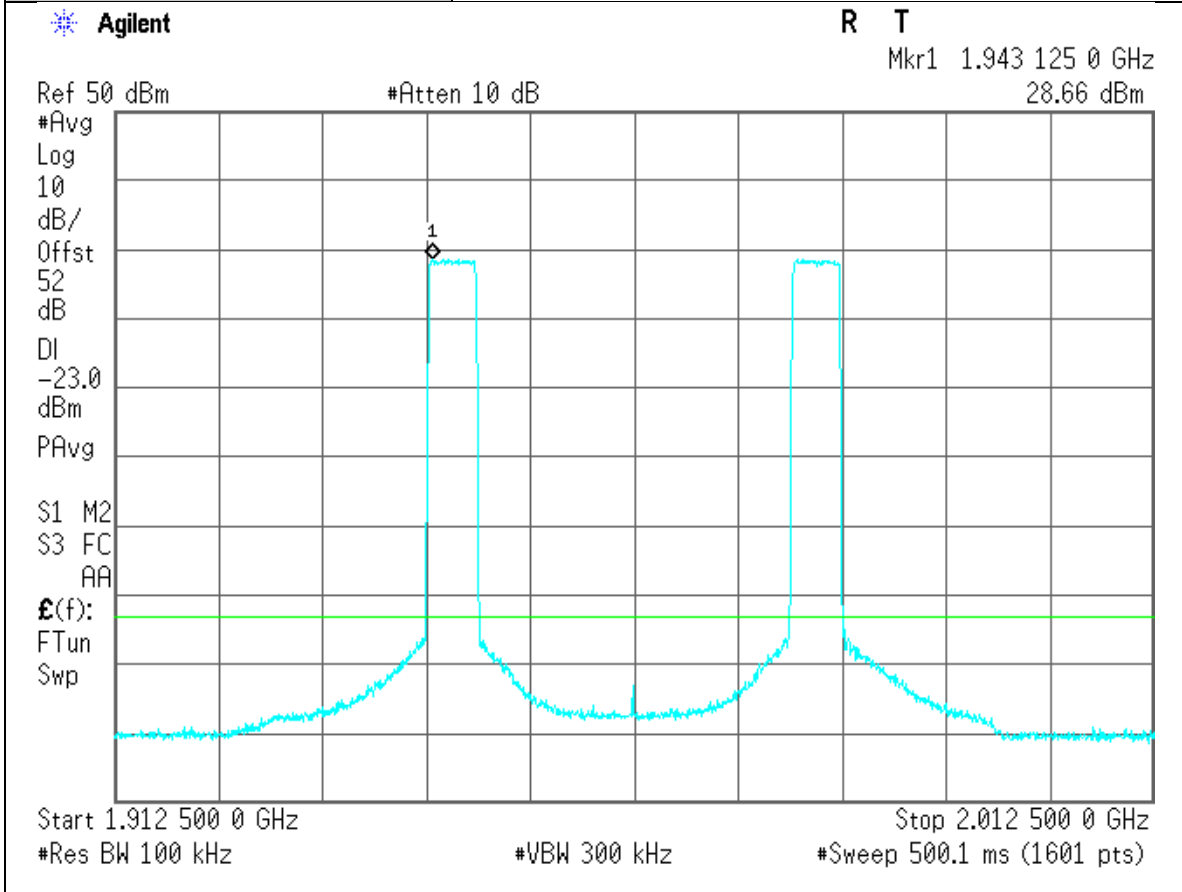

Project Number:	0048-130617-01
EUT:	AA190045
PARTS NO.:	RF151032
Tested By:	Wei Li
Temperature:	70°F
Humidity:	30%

Section:	Spurious Emissions at RF Output Port:
Plot Name:	Downlink, Inter-modulation
Configuration:	Input: Digital; Output: TX1 RF Output TM 11 5MHz Carrier BW, Hi freq

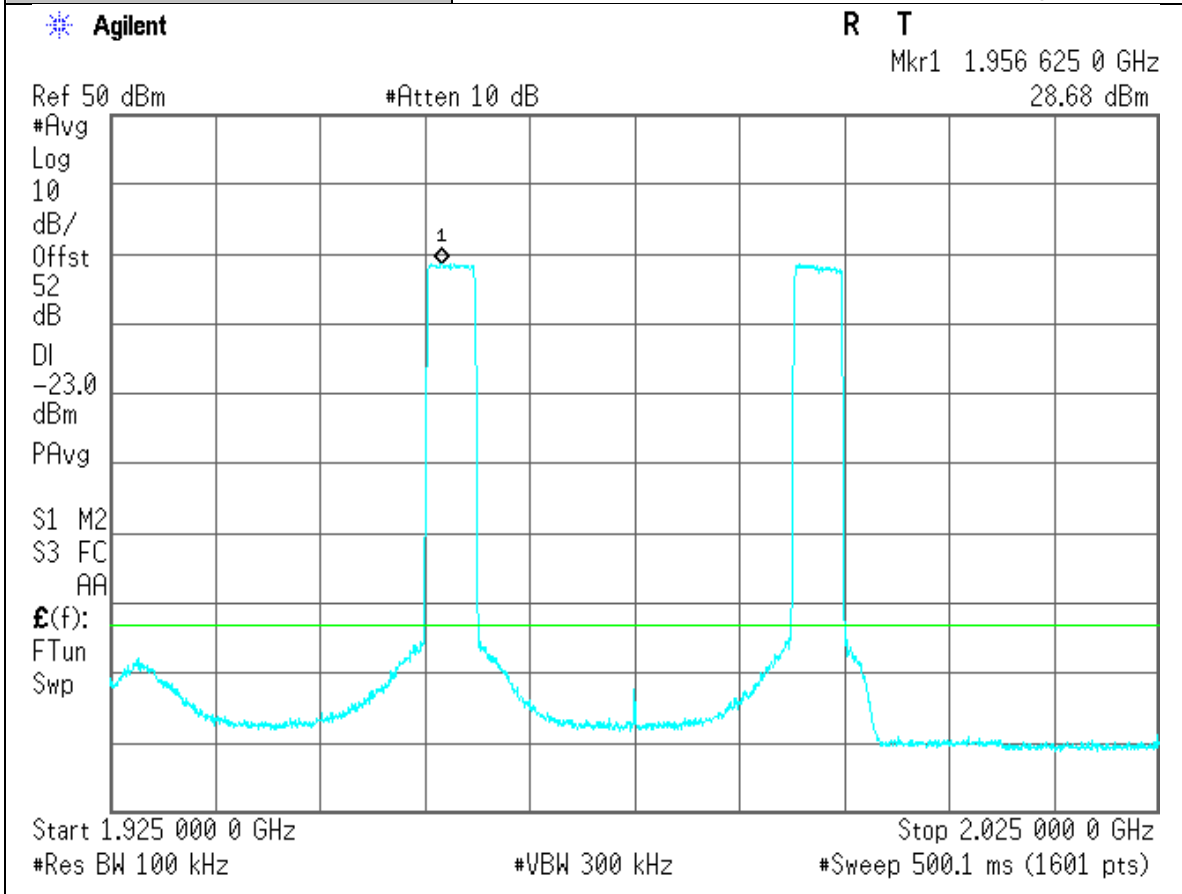

Project Number:	0048-130617-01
EUT:	AA190045
PARTS NO.:	RF151032
Tested By:	Wei Li
Temperature:	70°F
Humidity:	30%

Section:	Spurious Emissions at RF Output Port:
Plot Name:	Downlink, Inter-modulation
Configuration:	Input: Digital; Output: TX1 RF Output TM 11 10MHz Carrier BW, Low freq

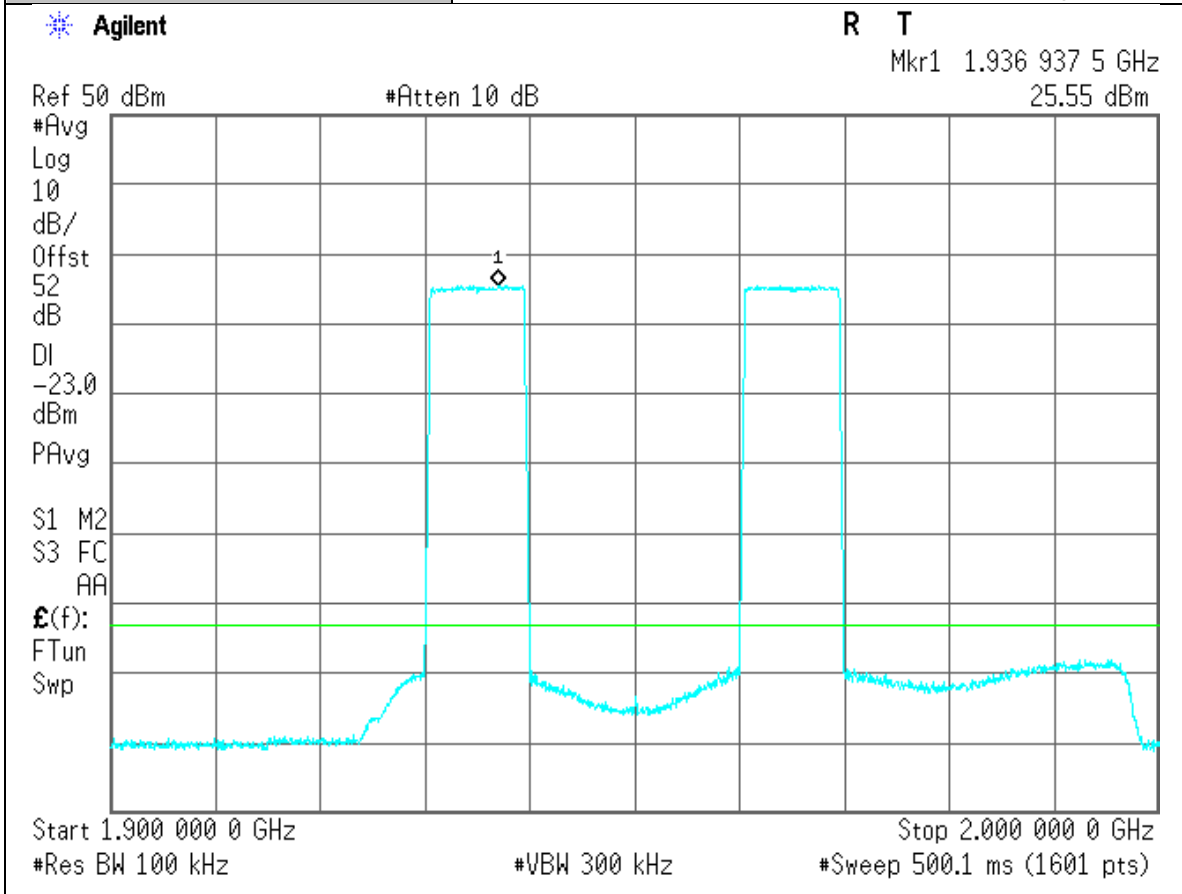

Project Number:	0048-130617-01
EUT:	AA190045
PARTS NO.:	RF151032
Tested By:	Wei Li
Temperature:	70°F
Humidity:	30%

Section:	Spurious Emissions at RF Output Port:
Plot Name:	Downlink, Inter-modulation
Configuration:	Input: Digital; Output: TX1 RF Output TM 11 10MHz Carrier BW, Mid freq

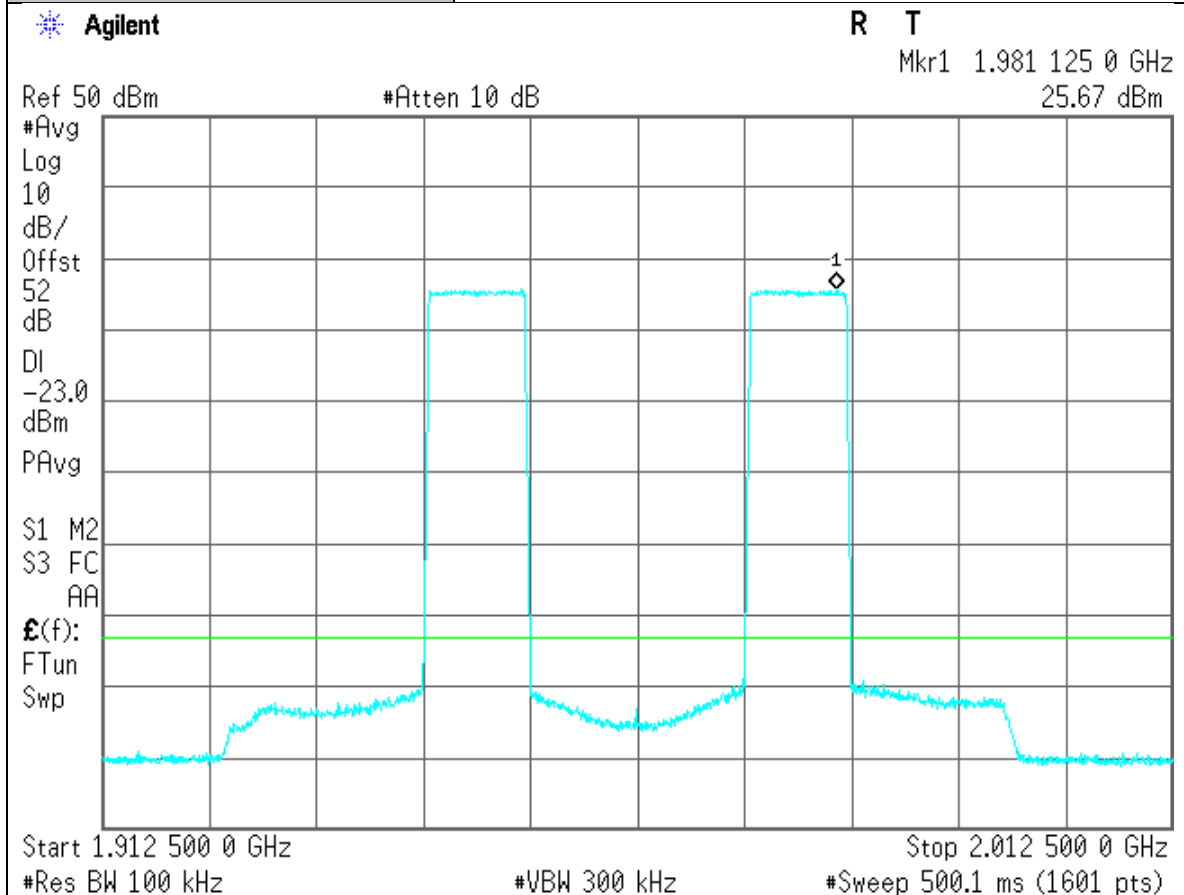

Project Number:	0048-130617-01
EUT:	AA190045
PARTS NO.:	RF151032
Tested By:	Wei Li
Temperature:	70°F
Humidity:	30%

Section:	Spurious Emissions at RF Output Port:
Plot Name:	Downlink, Inter-modulation
Configuration:	Input: Digital; Output: TX1 RF Output TM 11 10MHz Carrier BW, Hi freq

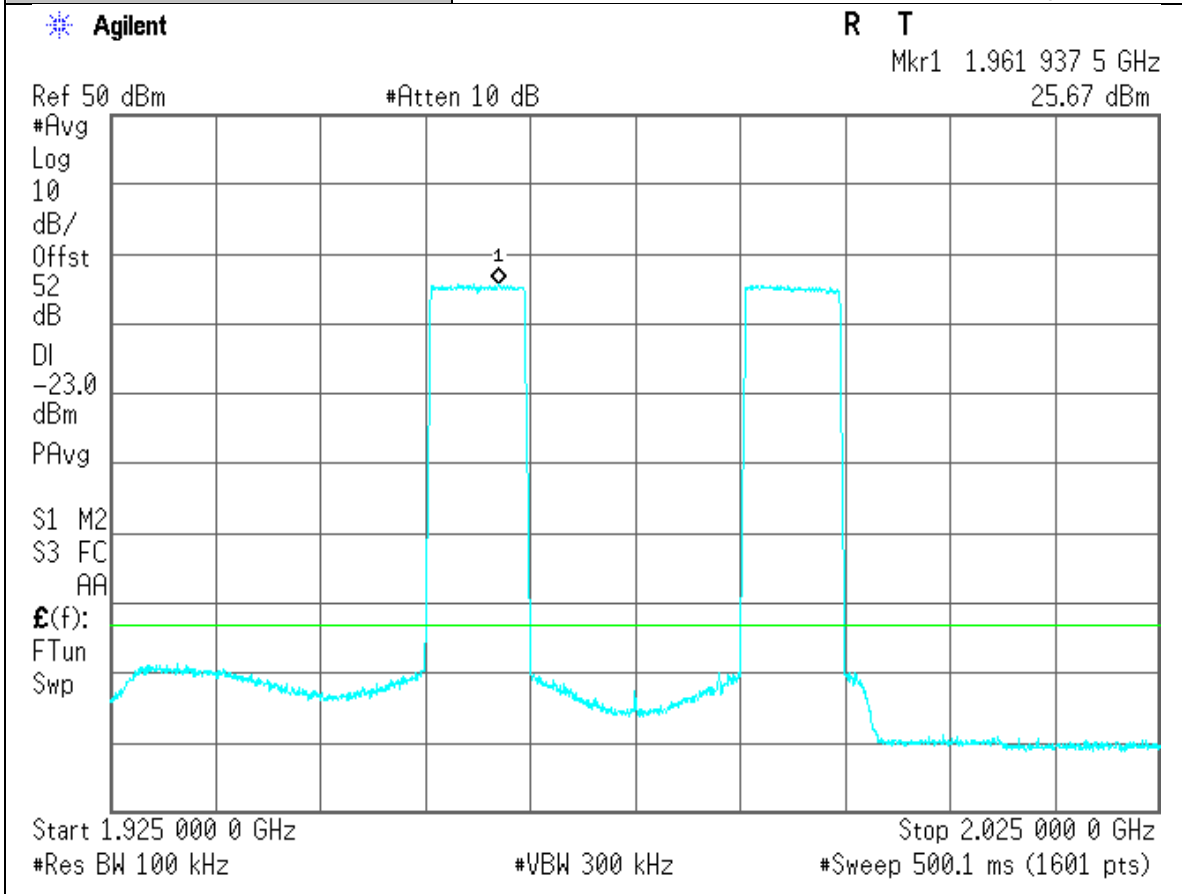

Project Number:	0048-130617-01
EUT:	AA190045
PARTS NO.:	RF151032
Tested By:	Wei Li
Temperature:	70°F
Humidity:	30%

Section:	Spurious Emissions at RF Output Port:
Plot Name:	Downlink, Inter-modulation
Configuration:	Input: Digital; Output: TX1 RF Output TM 11 5MHz Carrier BW, Low freq Adjacent Channels

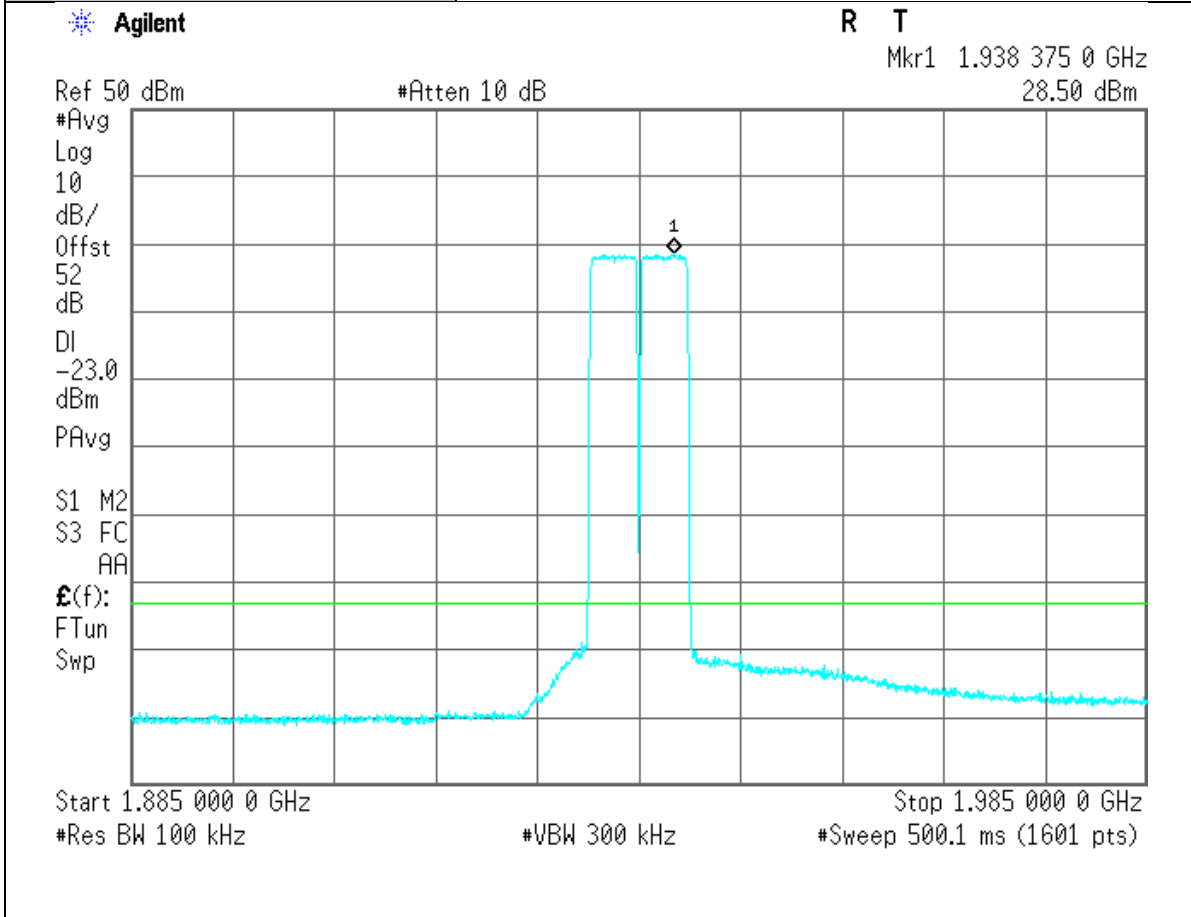

Project Number:	0048-130617-01
EUT:	AA190045
PARTS NO.:	RF151032
Tested By:	Wei Li
Temperature:	70°F
Humidity:	30%

Section:	Spurious Emissions at RF Output Port:
Plot Name:	Downlink, Inter-modulation
Configuration:	Input: Digital; Output: TX1 RF Output TM 11 5MHz Carrier BW, Mid freq Adjacent Channels

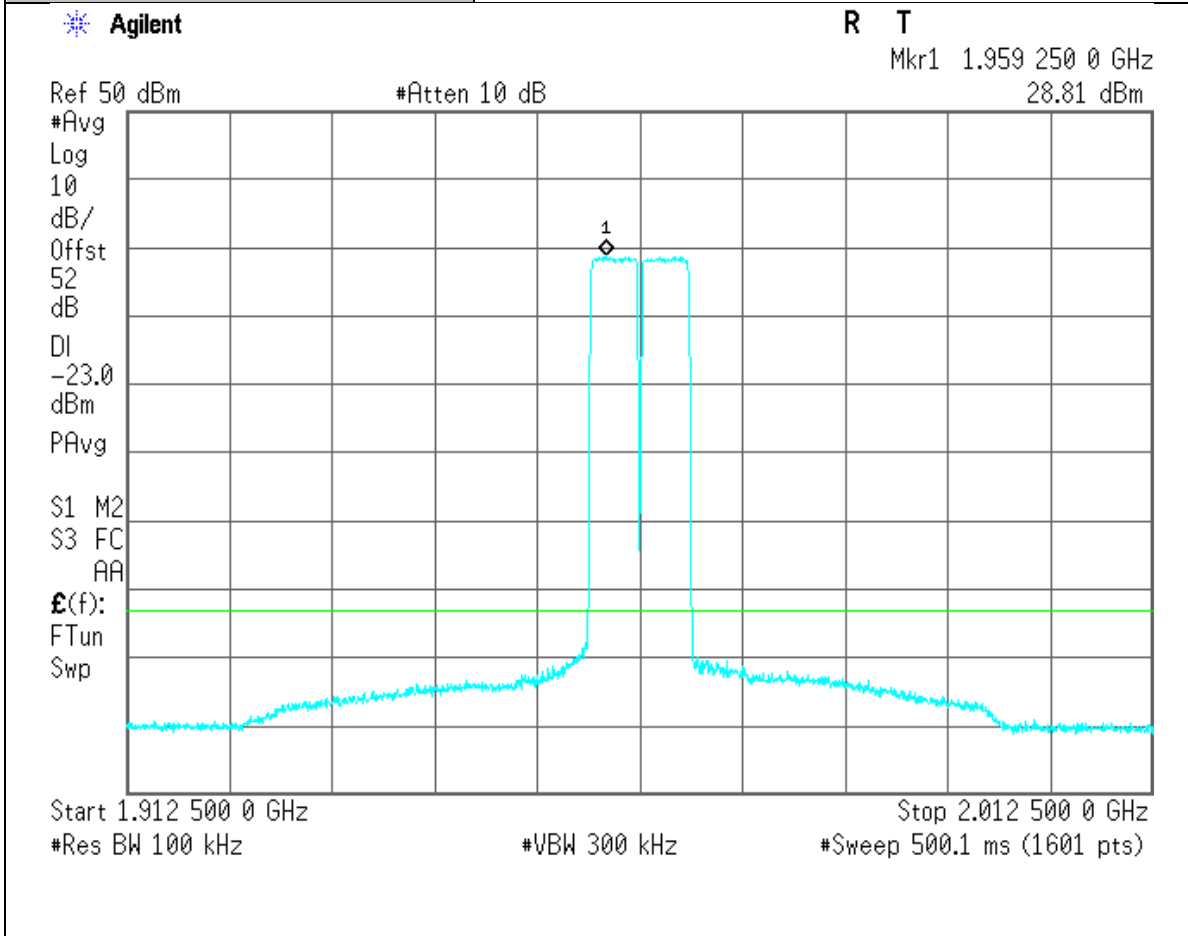

Project Number:	0048-130617-01
EUT:	AA190045
PARTS NO.:	RF151032
Tested By:	Wei Li
Temperature:	70°F
Humidity:	30%

Section:	Spurious Emissions at RF Output Port:
Plot Name:	Downlink, Inter-modulation
Configuration:	Input: Digital; Output: TX1 RF Output TM 11 5MHz Carrier BW, Hi freq Adjacent Channels

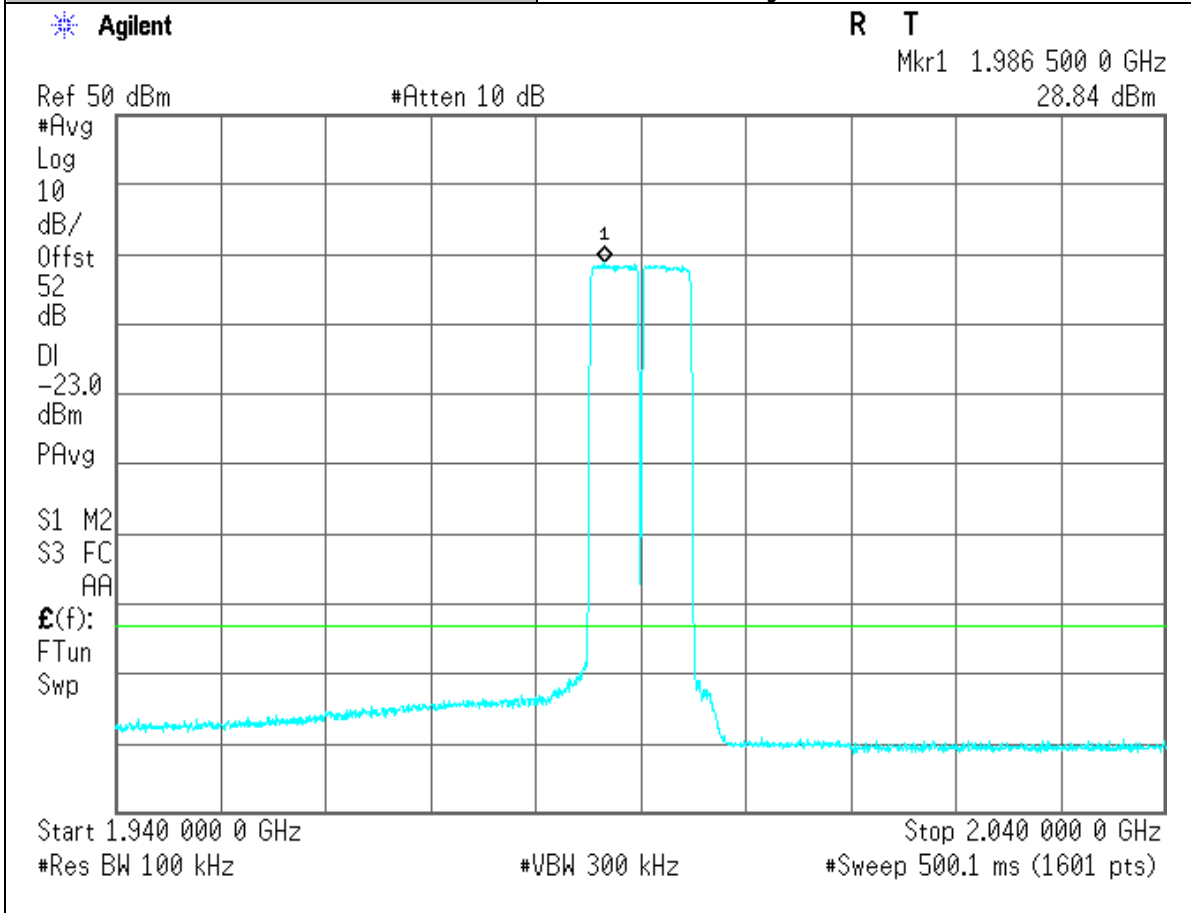

Project Number:	0048-130617-01
EUT:	AA190045
PARTS NO.:	RF151032
Tested By:	Wei Li
Temperature:	70°F
Humidity:	30%

Section:	Spurious Emissions at RF Output Port:
Plot Name:	Downlink, Inter-modulation
Configuration:	Input: Digital; Output: TX1 RF Output TM 11 10MHz Carrier BW, Low freq Adjacent Channels

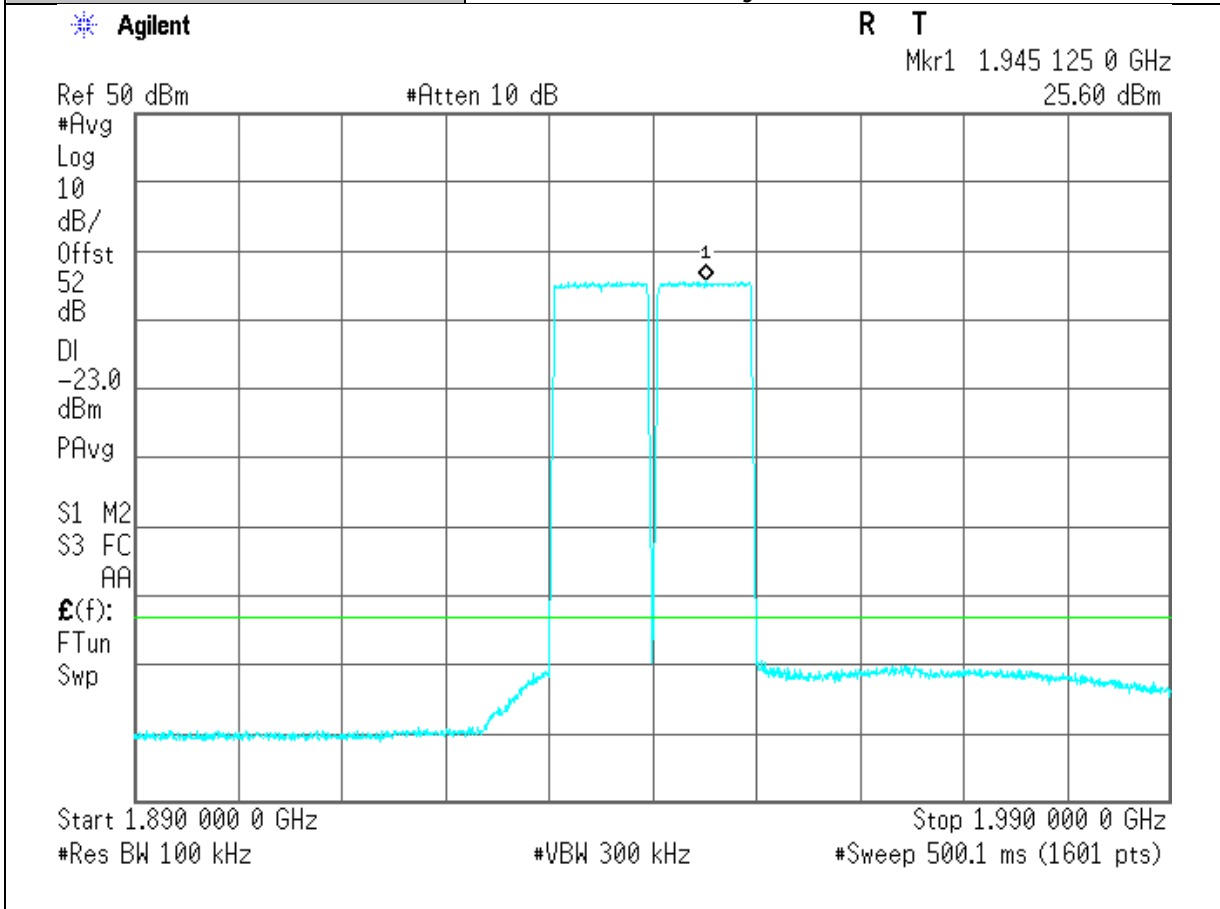

Project Number:	0048-130617-01
EUT:	AA190045
PARTS NO.:	RF151032
Tested By:	Wei Li
Temperature:	70°F
Humidity:	30%

Section:	Spurious Emissions at RF Output Port:
Plot Name:	Downlink, Inter-modulation
Configuration:	Input: Digital; Output: TX1 RF Output TM 11 10MHz Carrier BW, Mid freq Adjacent Channels

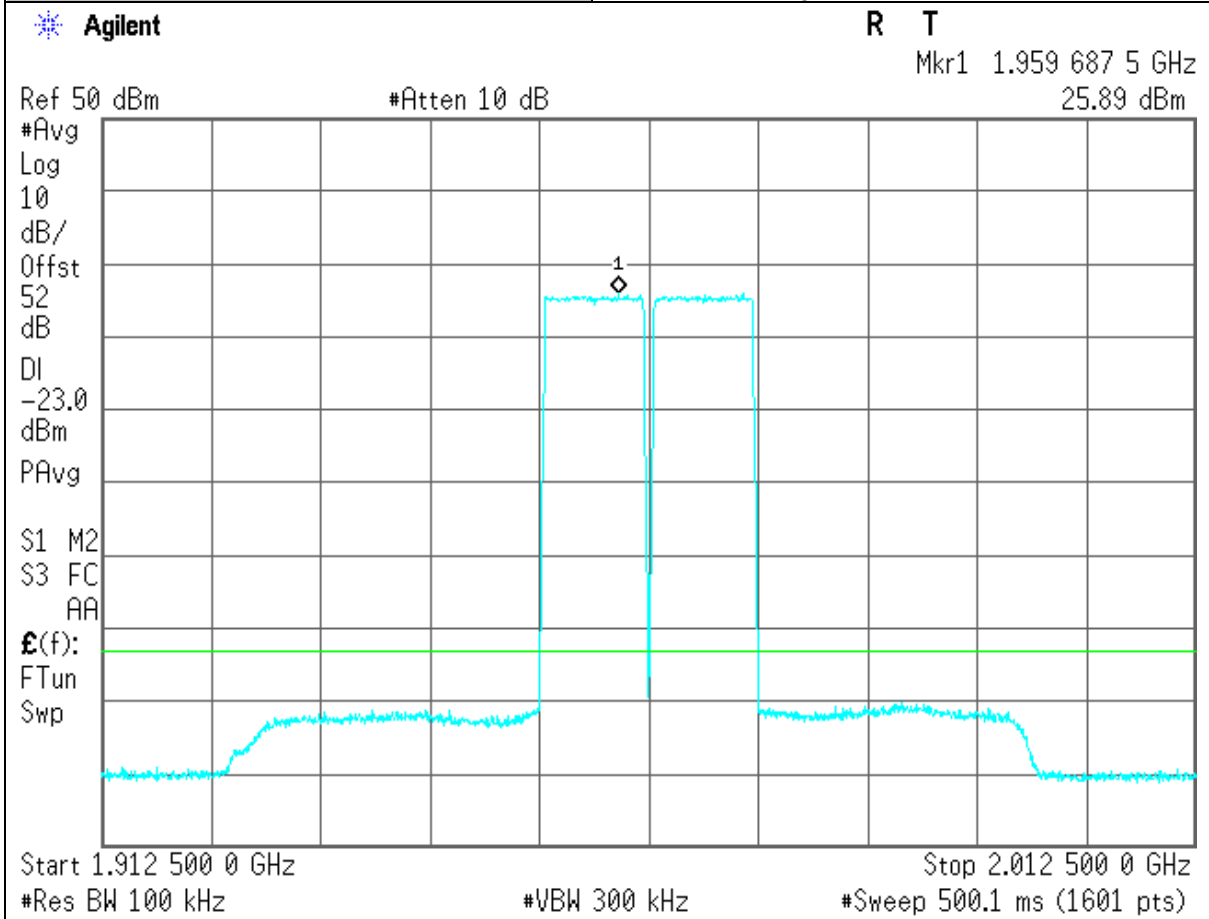

Project Number:	0048-130617-01
EUT:	AA190045
PARTS NO.:	RF151032
Tested By:	Wei Li
Temperature:	70°F
Humidity:	30%

Section:	Spurious Emissions at RF Output Port:
Plot Name:	Downlink, Inter-modulation
Configuration:	Input: Digital; Output: TX1 RF Output TM 11 10MHz Carrier BW, Hi freq Adjacent Channels

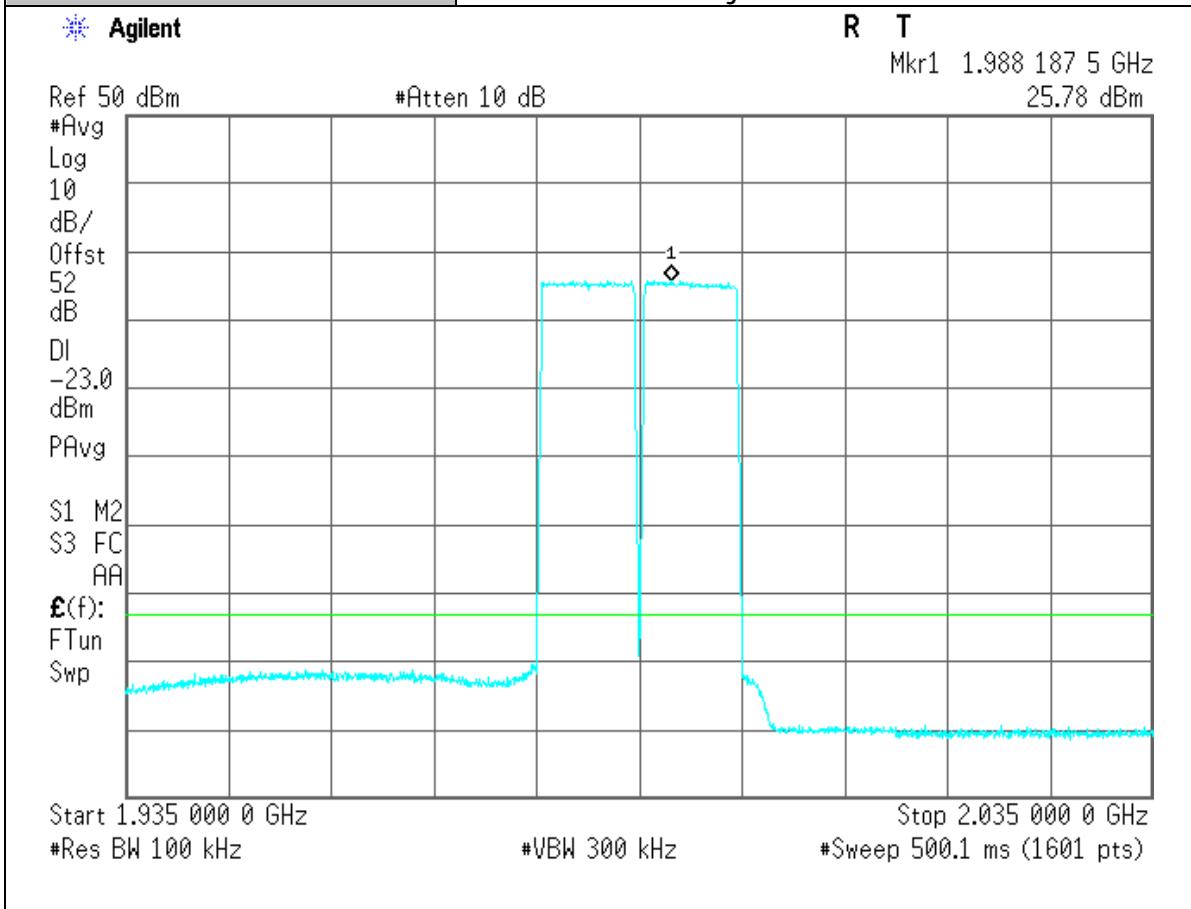

Project Number:	0048-130617-01
EUT:	AA190045
PARTS NO.:	RF151032
Tested By:	Wei Li
Temperature:	70°F
Humidity:	30%

Section:	Spurious Emissions at RF Output Port:
Plot Name:	Downlink, Inter-modulation
Configuration:	Input: Digital; Output: TX1 RF Output TM 31 5MHz Carrier BW, Low freq

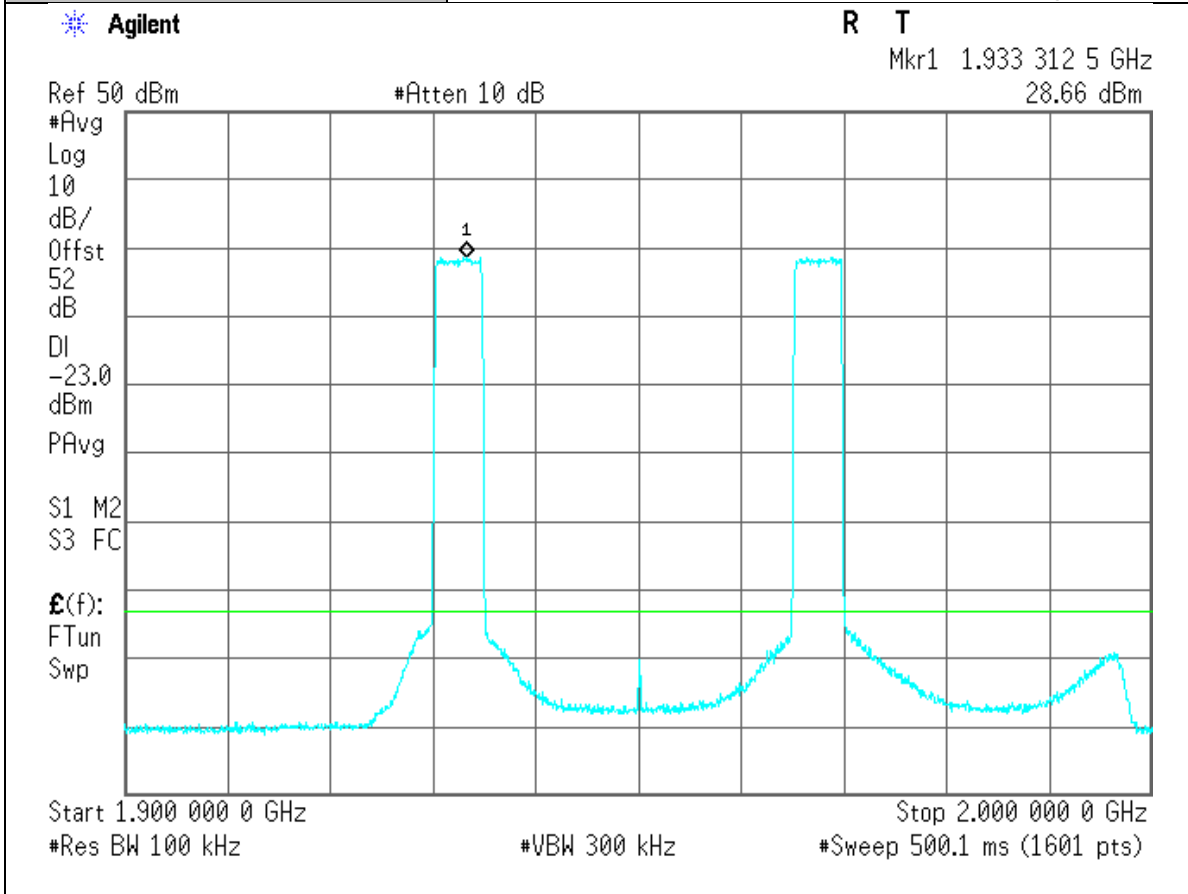

Project Number:	0048-130617-01
EUT:	AA190045
PARTS NO.:	RF151032
Tested By:	Wei Li
Temperature:	70°F
Humidity:	30%

Section:	Spurious Emissions at RF Output Port:
Plot Name:	Downlink, Inter-modulation
Configuration:	Input: Digital; Output: TX1 RF Output TM 31 5MHz Carrier BW, Mid freq

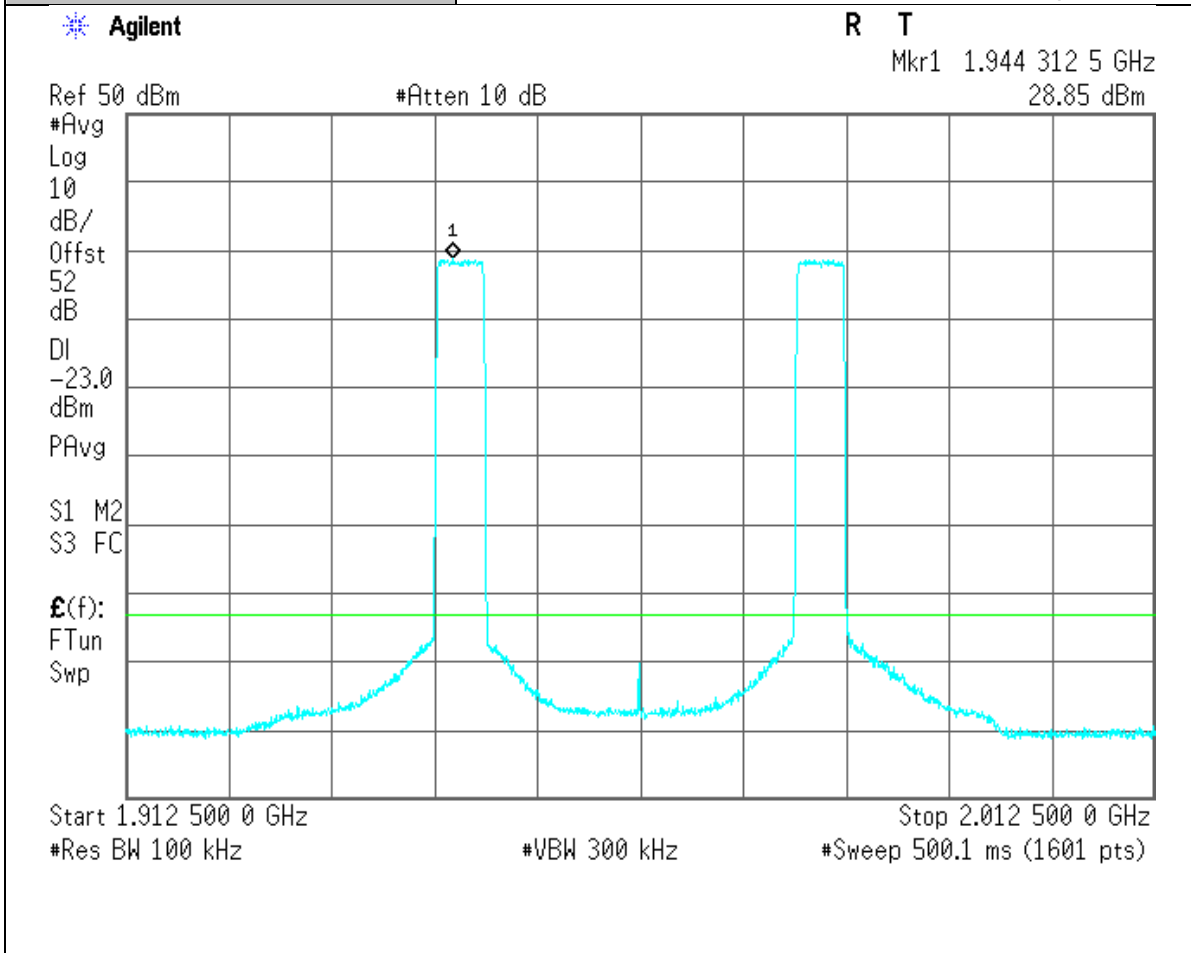

Project Number:	0048-130617-01
EUT:	AA190045
PARTS NO.:	RF151032
Tested By:	Wei Li
Temperature:	70°F
Humidity:	30%

Section:	Spurious Emissions at RF Output Port:
Plot Name:	Downlink, Inter-modulation
Configuration:	Input: Digital; Output: TX1 RF Output TM 31 5MHz Carrier BW, Hi freq

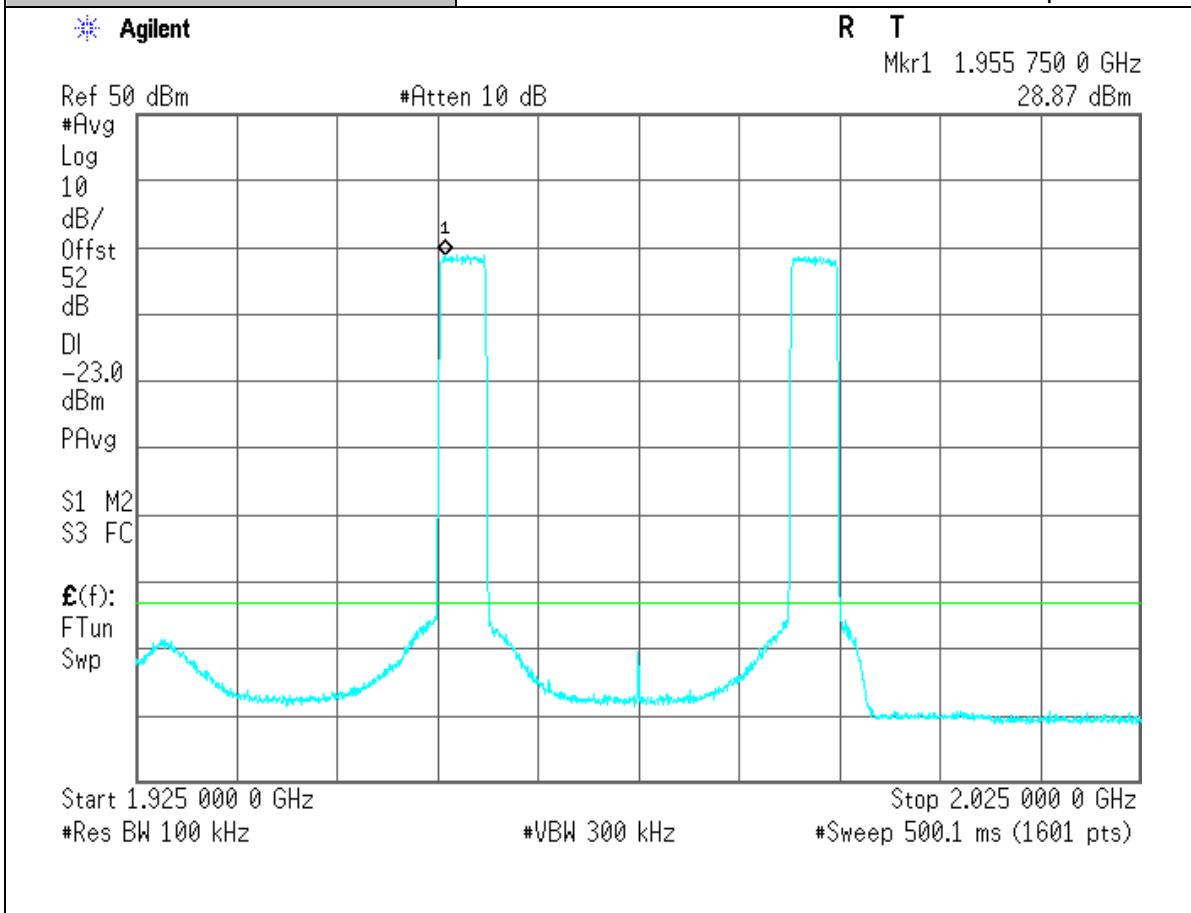

Project Number:	0048-130617-01
EUT:	AA190045
PARTS NO.:	RF151032
Tested By:	Wei Li
Temperature:	70°F
Humidity:	30%

Section:	Spurious Emissions at RF Output Port:
Plot Name:	Downlink, Inter-modulation
Configuration:	Input: Digital; Output: TX1 RF Output TM 31 10MHz Carrier BW, Low freq

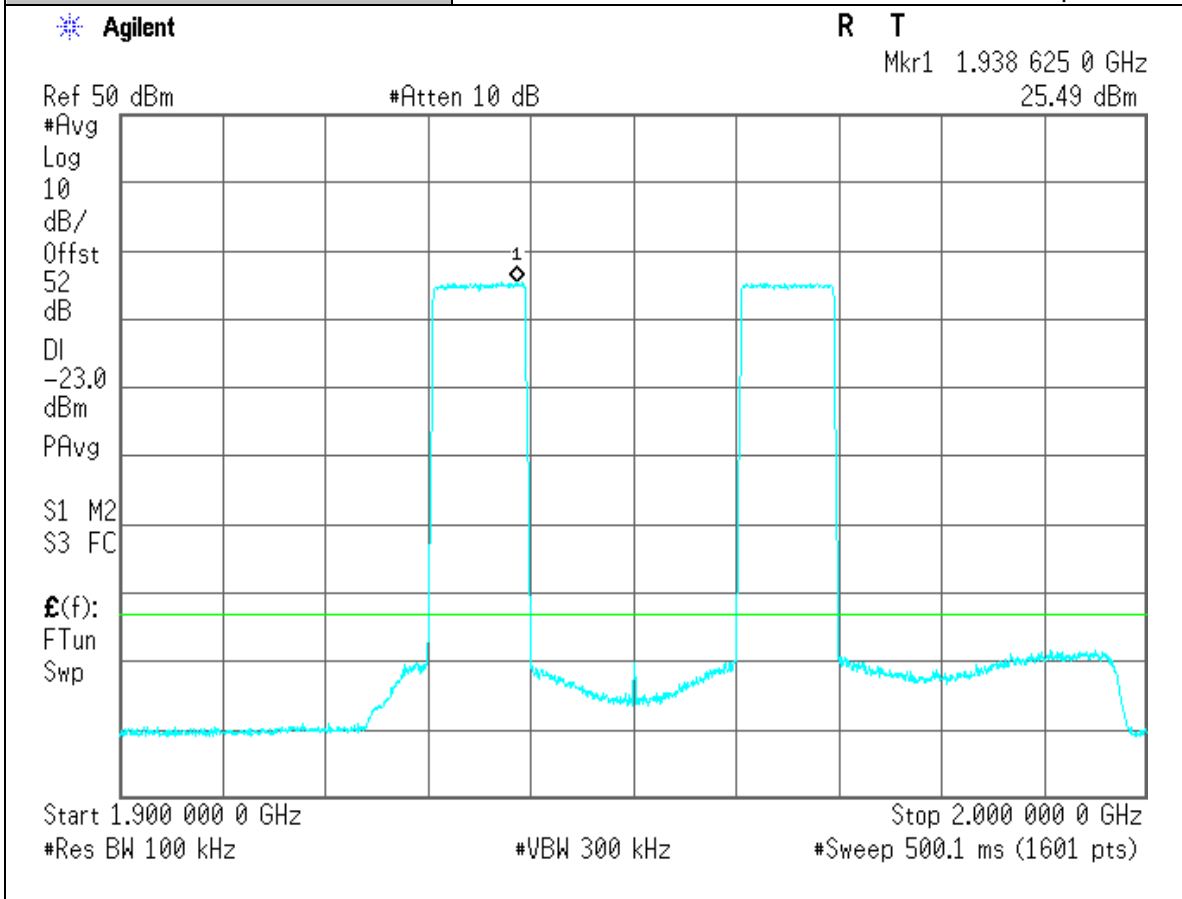

Project Number:	0048-130617-01
EUT:	AA190045
PARTS NO.:	RF151032
Tested By:	Wei Li
Temperature:	70°F
Humidity:	30%

Section:	Spurious Emissions at RF Output Port:
Plot Name:	Downlink, Inter-modulation
Configuration:	Input: Digital; Output: TX1 RF Output TM 31 10MHz Carrier BW, Mid freq

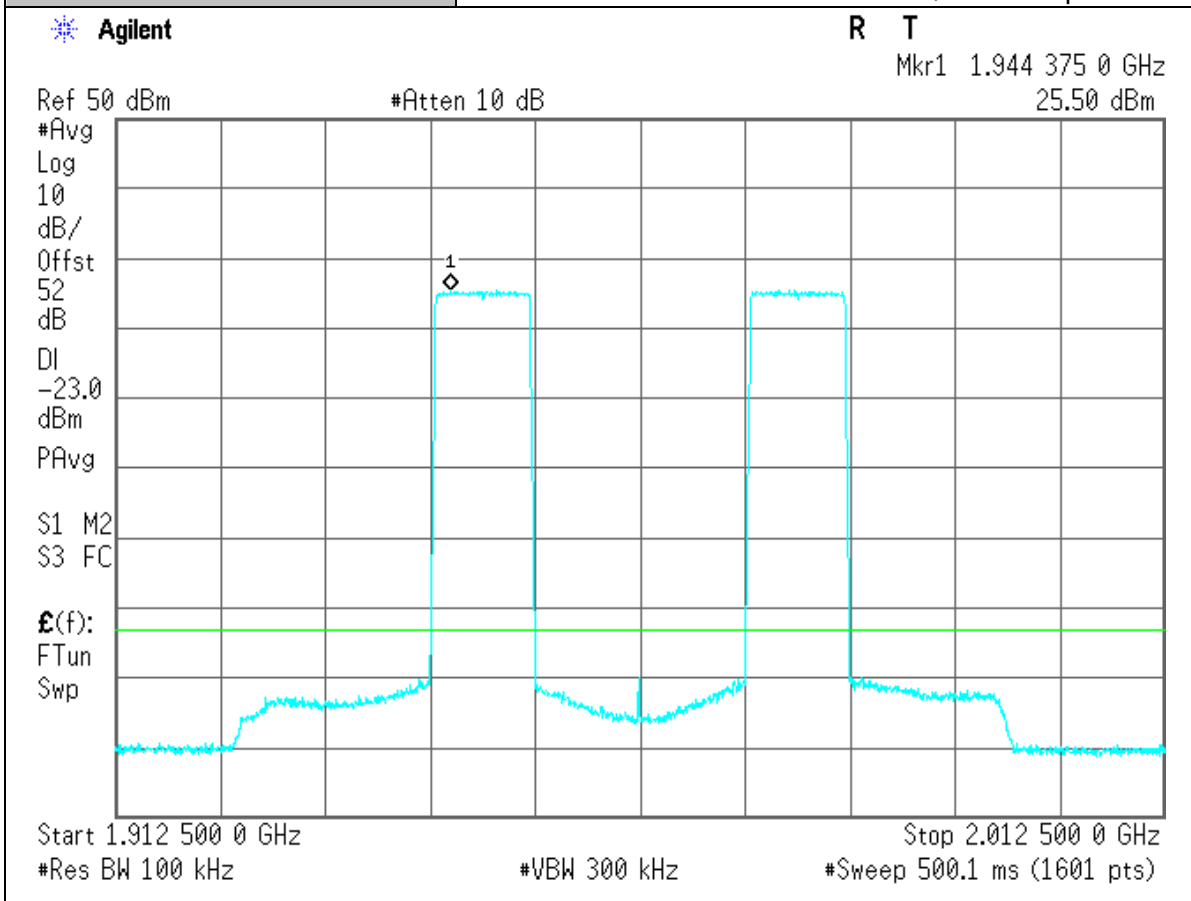

Project Number:	0048-130617-01
EUT:	AA190045
PARTS NO.:	RF151032
Tested By:	Wei Li
Temperature:	70°F
Humidity:	30%

Section:	Spurious Emissions at RF Output Port:
Plot Name:	Downlink, Inter-modulation
Configuration:	Input: Digital; Output: TX1 RF Output TM 31 10MHz Carrier BW, Hi freq

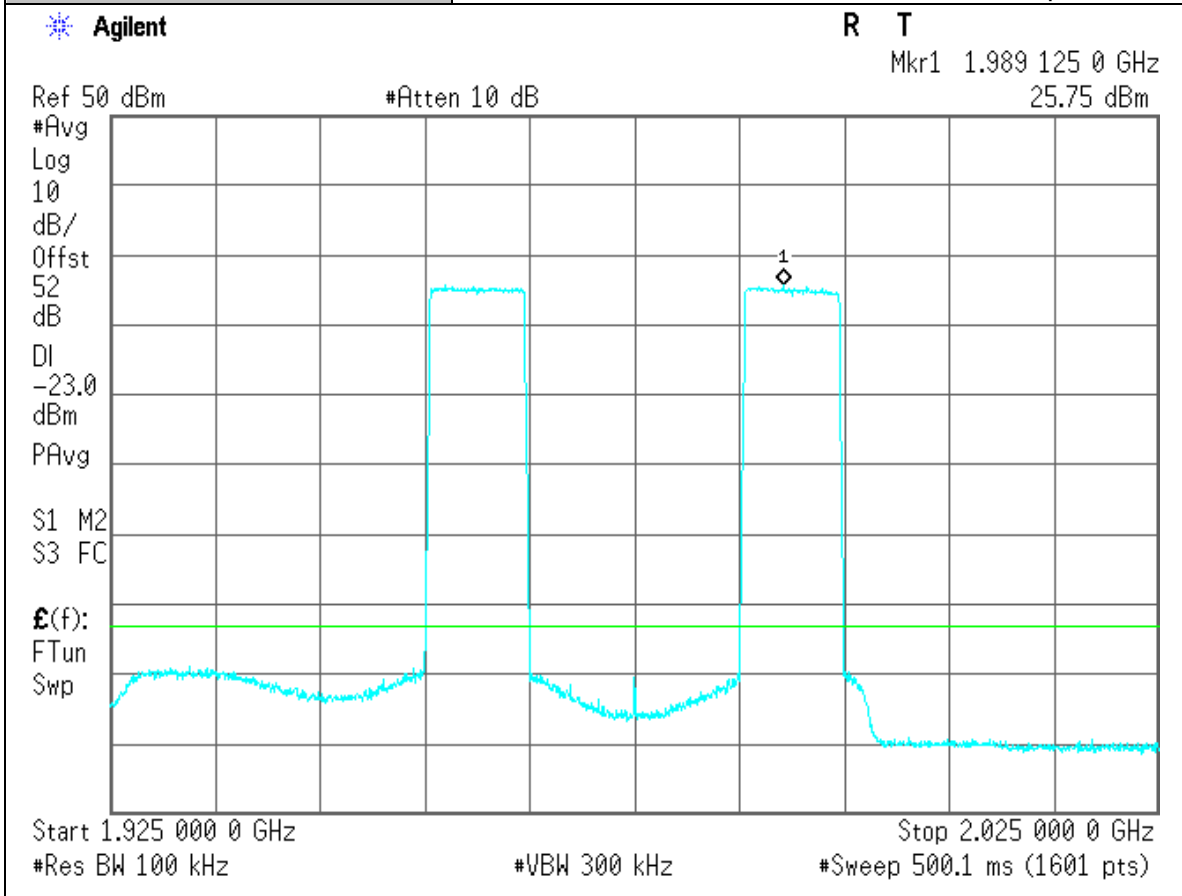

Project Number:	0048-130617-01
EUT:	AA190045
PARTS NO.:	RF151032
Tested By:	Wei Li
Temperature:	70°F
Humidity:	30%

Section:	Spurious Emissions at RF Output Port:
Plot Name:	Downlink, Inter-modulation
Configuration:	Input: Digital; Output: TX1 RF Output TM 31 5MHz Carrier BW, Low freq Adjacent Channels

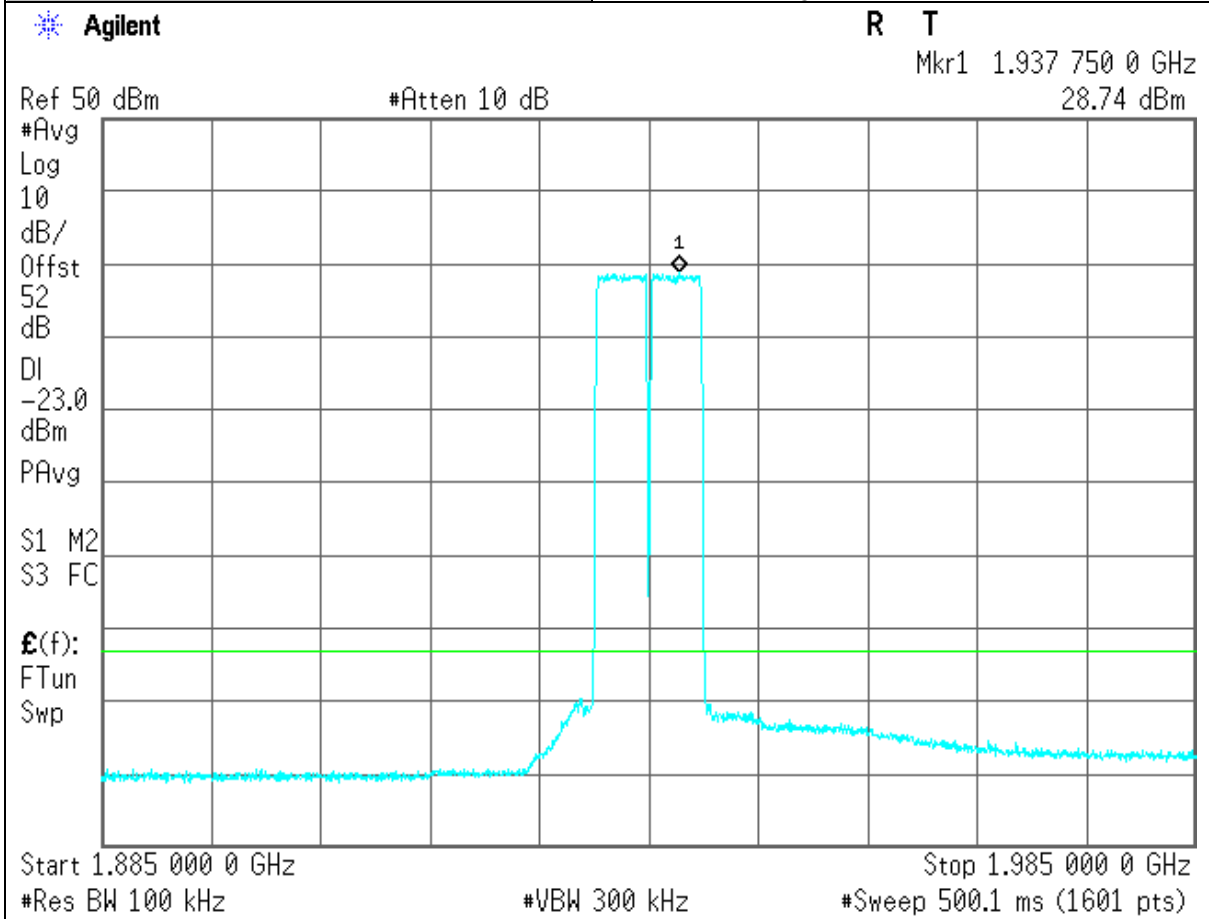

Project Number:	0048-130617-01
EUT:	AA190045
PARTS NO.:	RF151032
Tested By:	Wei Li
Temperature:	70°F
Humidity:	30%

Section:	Spurious Emissions at RF Output Port:
Plot Name:	Downlink, Inter-modulation
Configuration:	Input: Digital; Output: TX1 RF Output TM 31 5MHz Carrier BW, Mid freq Adjacent Channels

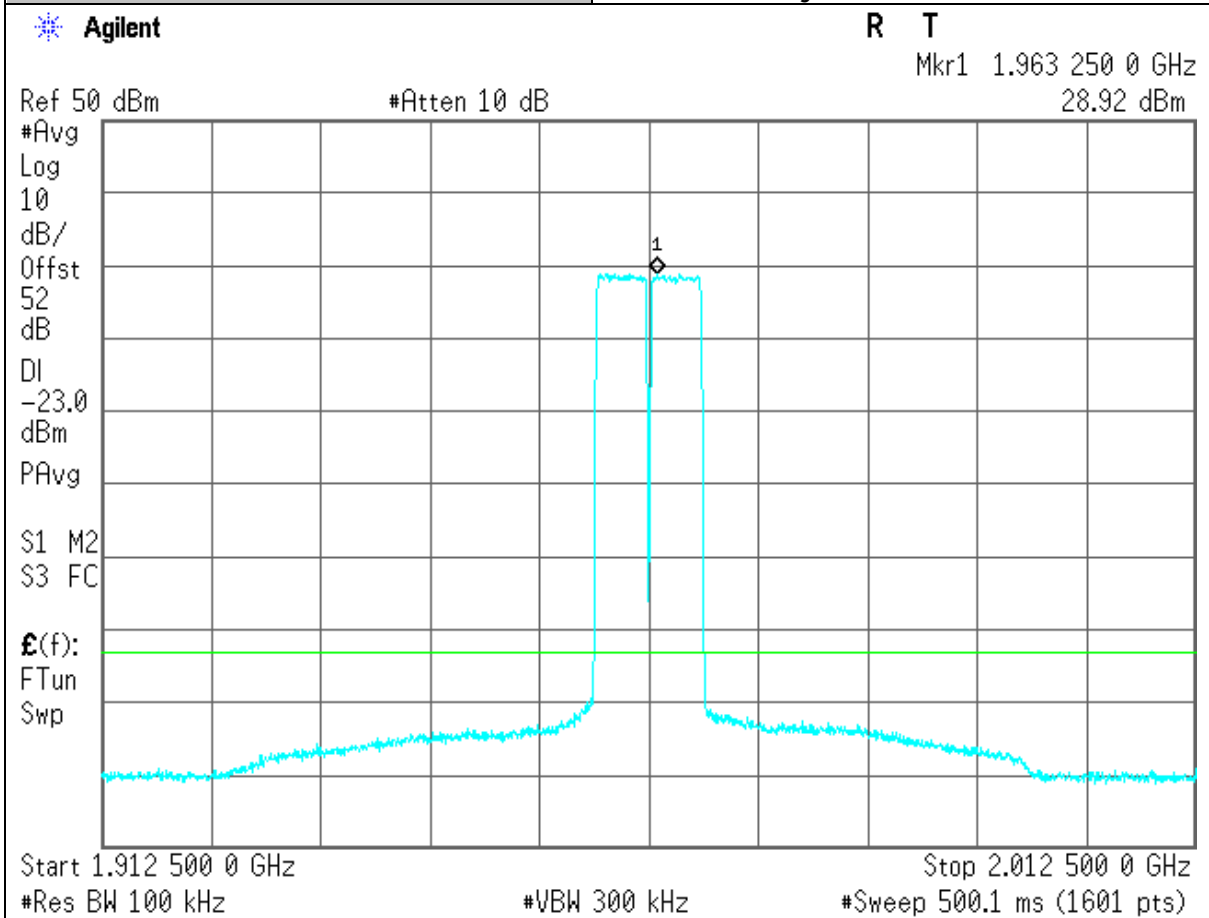

Project Number:	0048-130617-01
EUT:	AA190045
PARTS NO.:	RF151032
Tested By:	Wei Li
Temperature:	70°F
Humidity:	30%

Section:	Spurious Emissions at RF Output Port:
Plot Name:	Downlink, Inter-modulation
Configuration:	Input: Digital; Output: TX1 RF Output TM 31 5MHz Carrier BW, Hi freq Adjacent Channels

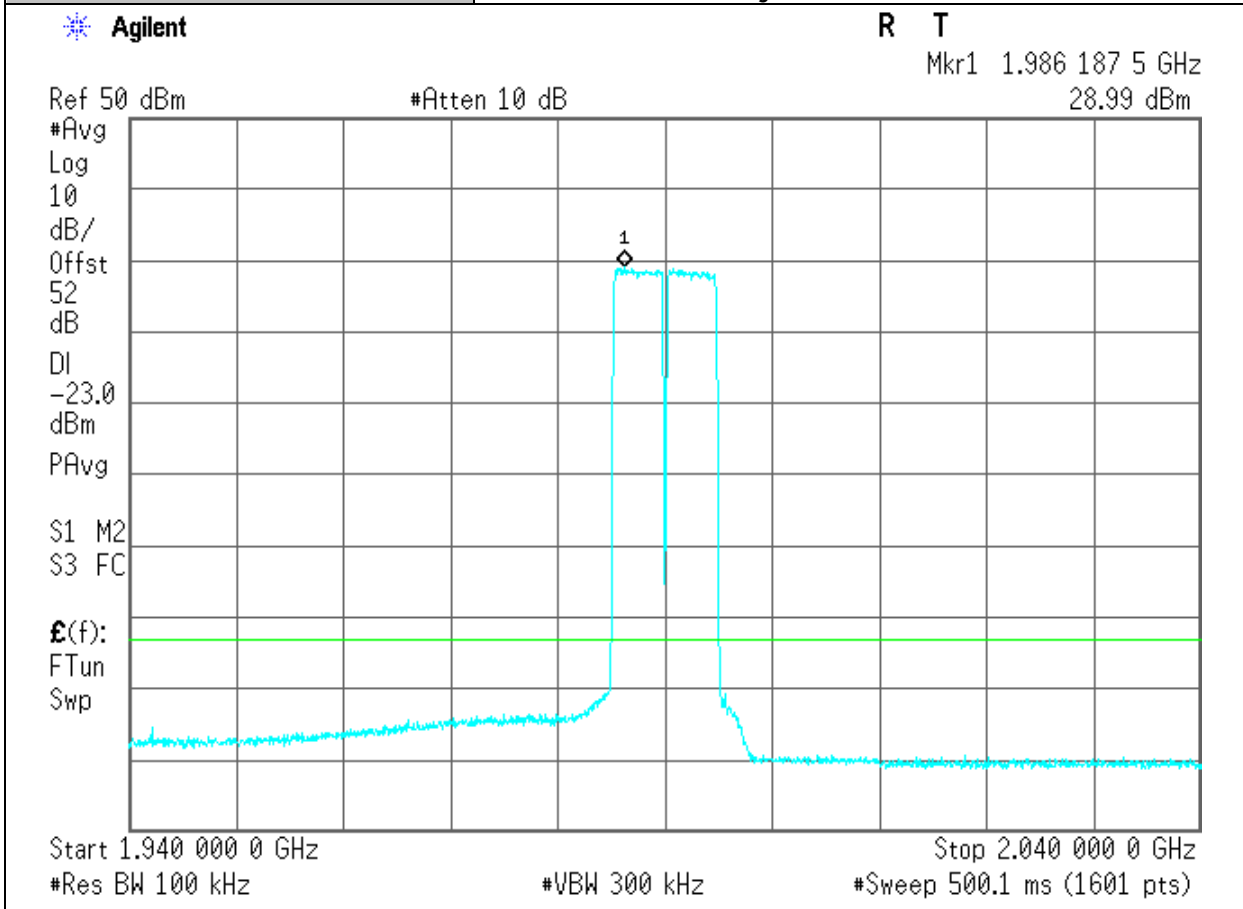

Project Number:	0048-130617-01
EUT:	AA190045
PARTS NO.:	RF151032
Tested By:	Wei Li
Temperature:	70°F
Humidity:	30%

Section:	Spurious Emissions at RF Output Port:
Plot Name:	Downlink, Inter-modulation
Configuration:	Input: Digital; Output: TX1 RF Output TM 31 10MHz Carrier BW, Low freq Adjacent Channels

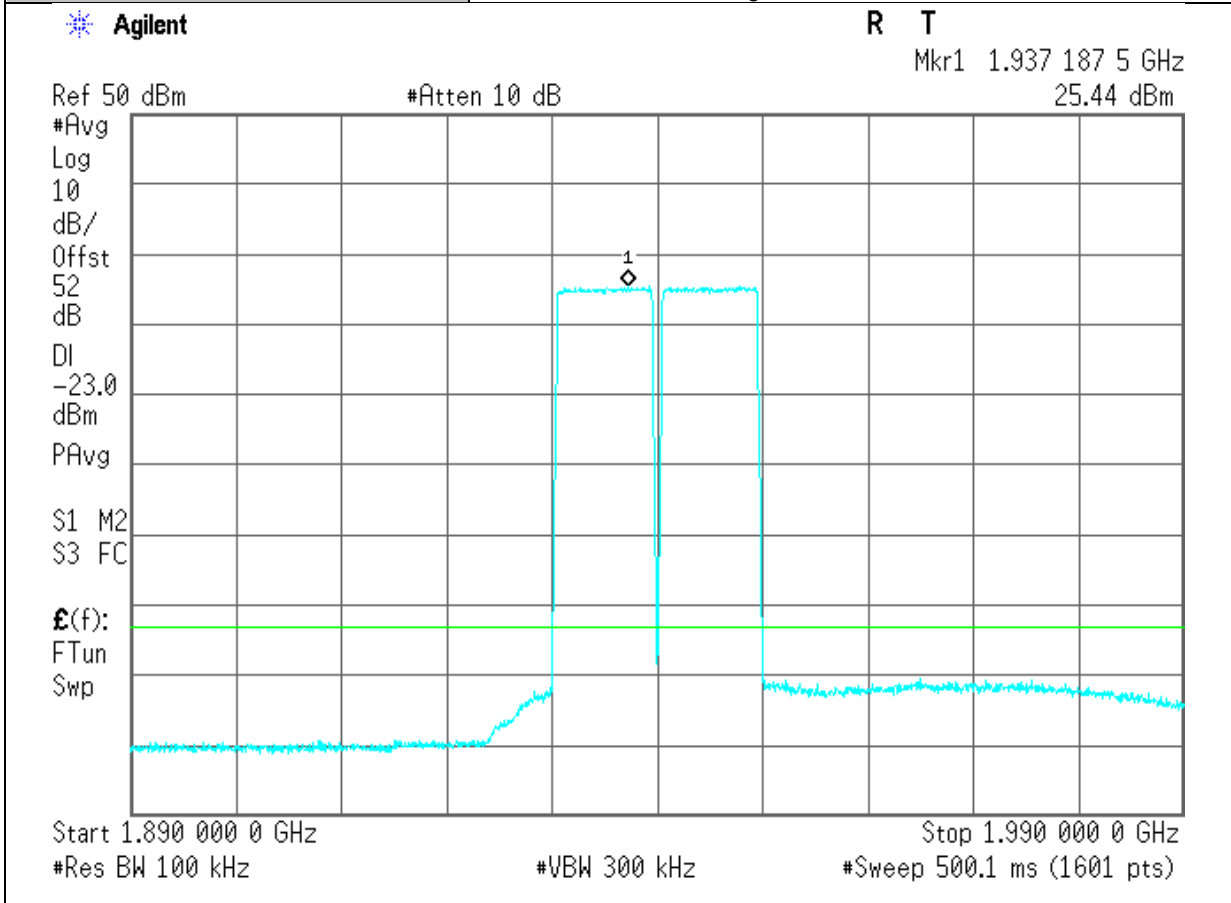

Project Number:	0048-130617-01
EUT:	AA190045
PARTS NO.:	RF151032
Tested By:	Wei Li
Temperature:	70°F
Humidity:	30%

Section:	Spurious Emissions at RF Output Port:
Plot Name:	Downlink, Inter-modulation
Configuration:	Input: Digital; Output: TX1 RF Output TM 31 10MHz Carrier BW, Mid freq Adjacent Channels

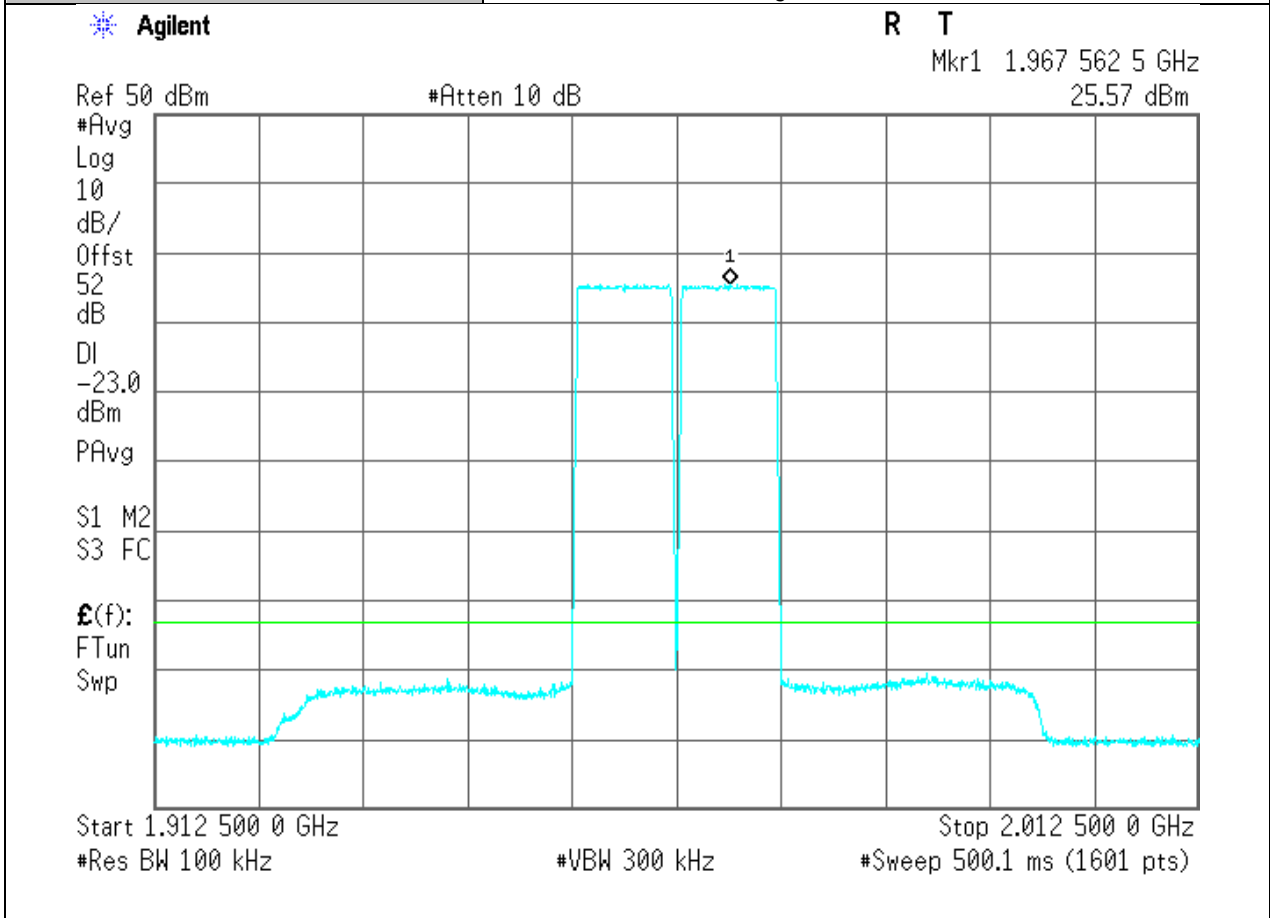

Project Number:	0048-130617-01
EUT:	AA190045
PARTS NO.:	RF151032
Tested By:	Wei Li
Temperature:	70°F
Humidity:	30%

Section:	Spurious Emissions at RF Output Port:
Plot Name:	Downlink, Inter-modulation
Configuration:	Input: Digital; Output: TX1 RF Output TM 31 10MHz Carrier BW, Hi freq Adjacent Channels

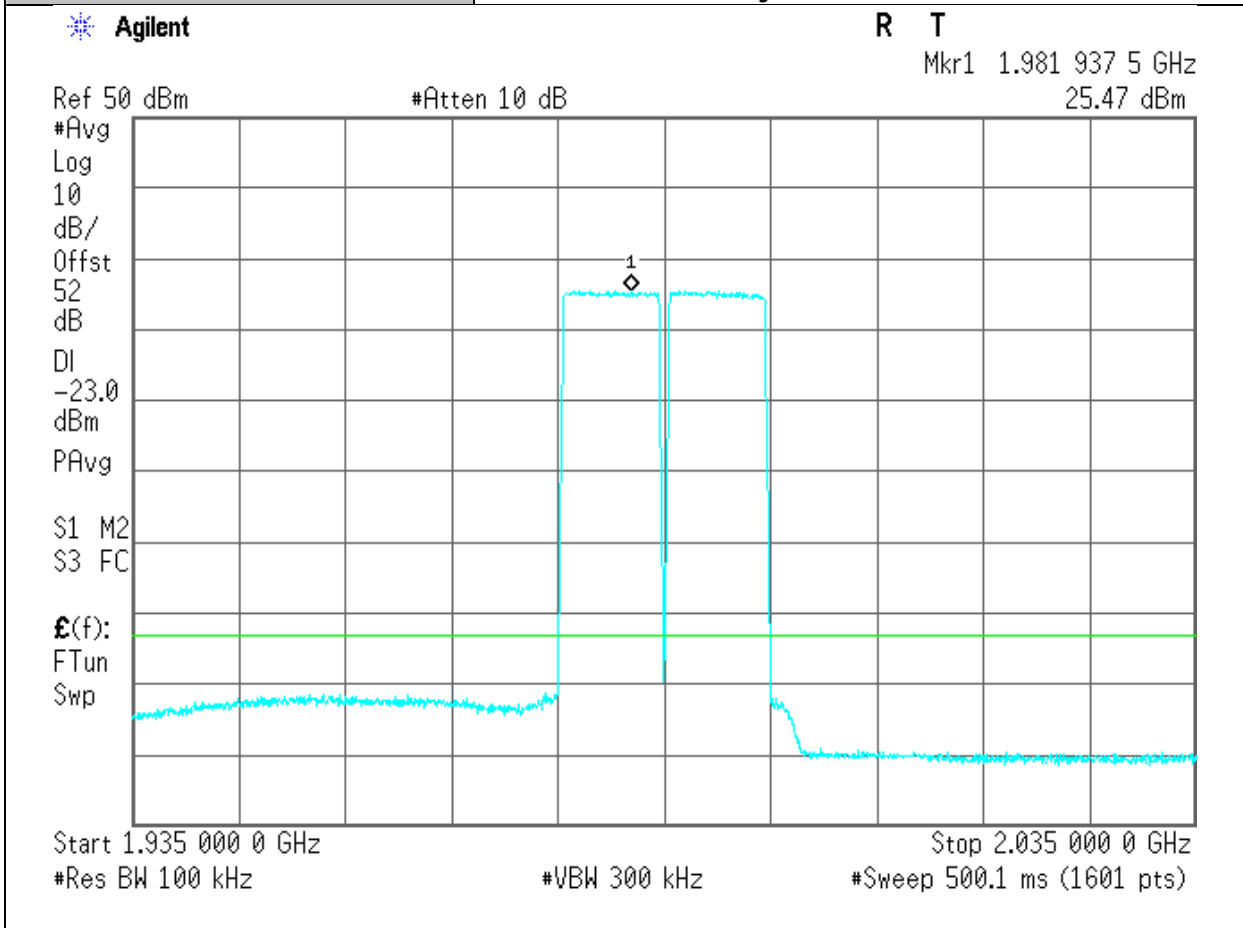

Project Number:	0048-130617-01
EUT:	AA190045
PARTS NO.:	RF151032
Tested By:	Wei Li
Temperature:	70°F
Humidity:	30%

Section:	Spurious Emissions at RF Output Port:
Plot Name:	Downlink, Inter-modulation
Configuration:	Input: Digital; Output: TX1 RF Output TM 32 5MHz Carrier BW, Low freq

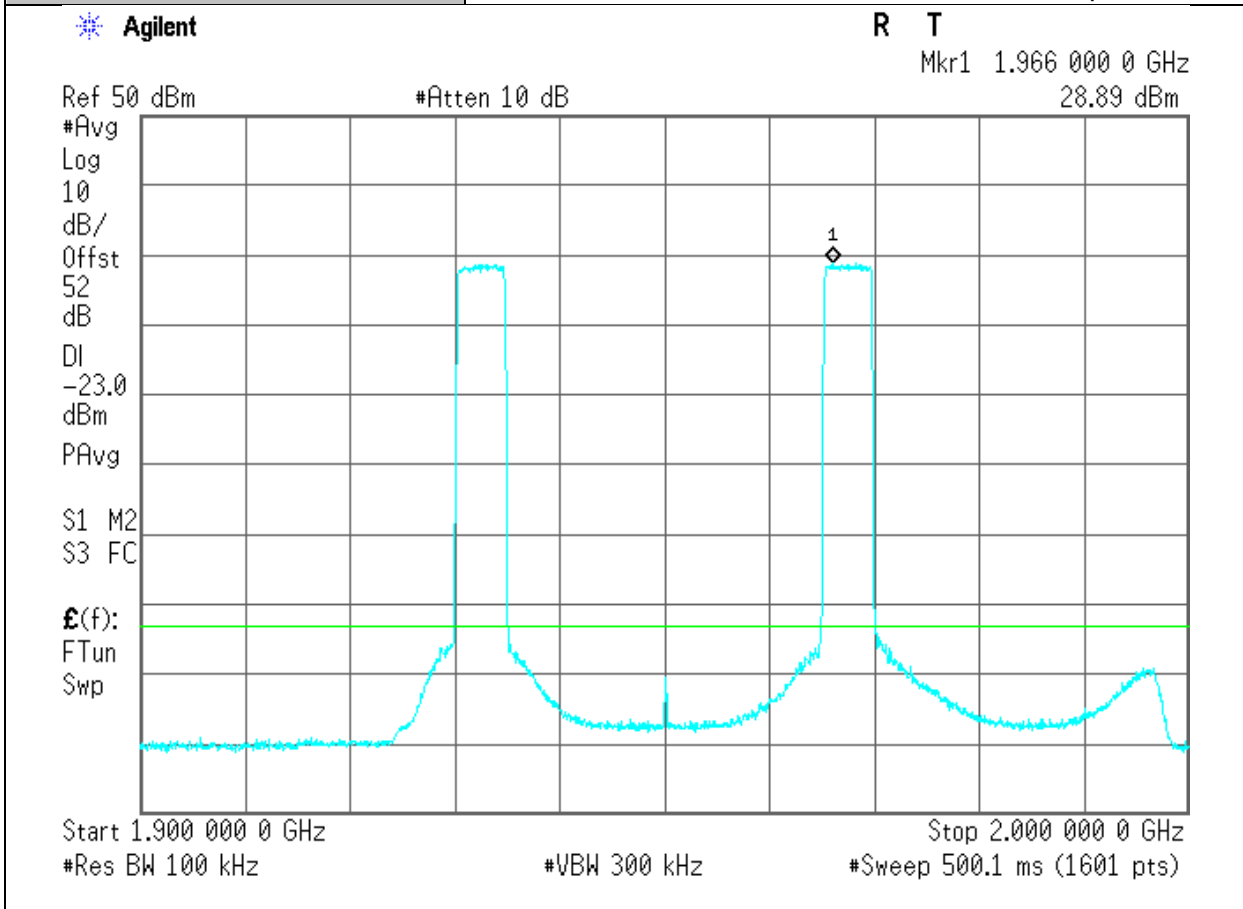

Project Number:	0048-130617-01
EUT:	AA190045
PARTS NO.:	RF151032
Tested By:	Wei Li
Temperature:	70°F
Humidity:	30%

Section:	Spurious Emissions at RF Output Port:
Plot Name:	Downlink, Inter-modulation
Configuration:	Input: Digital; Output: TX1 RF Output TM 32 5MHz Carrier BW, Mid freq

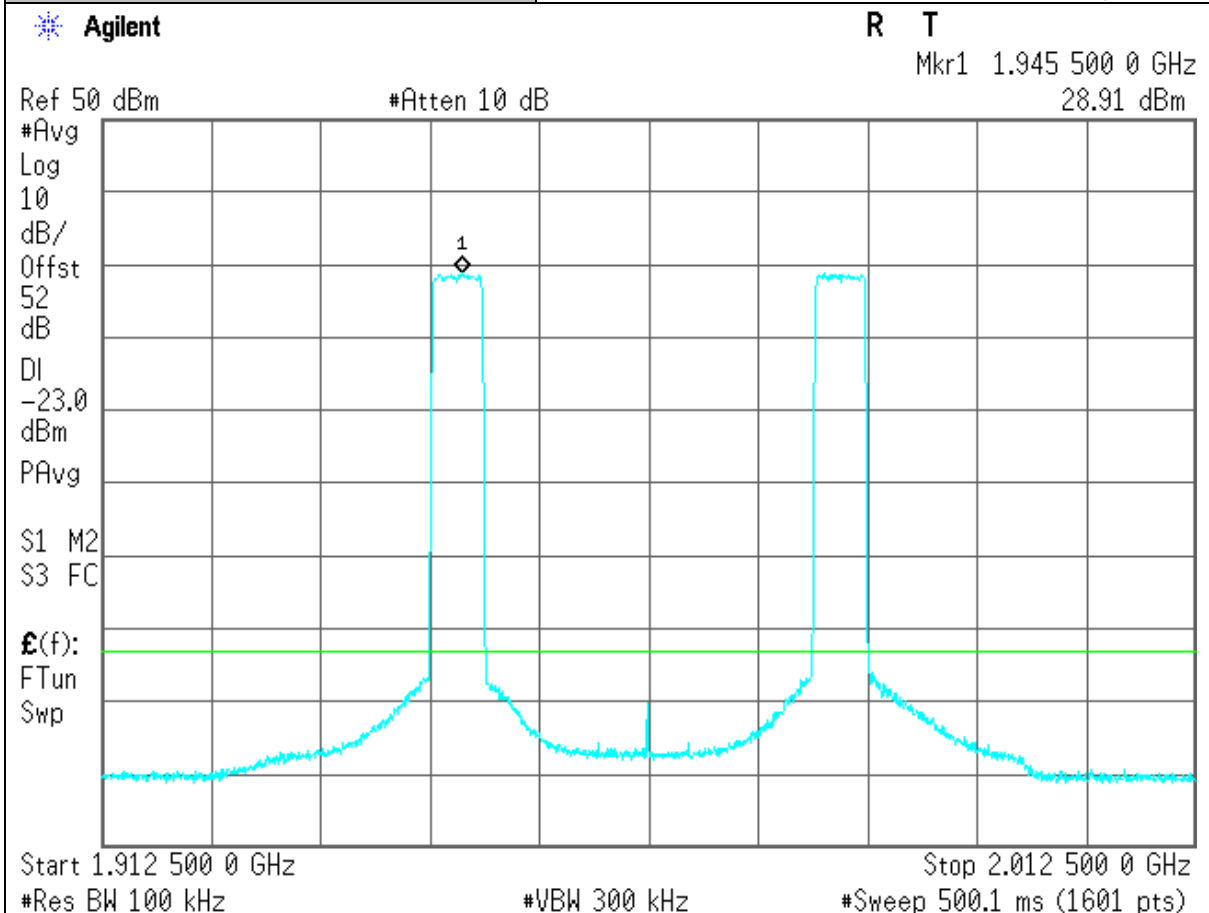

Project Number:	0048-130617-01
EUT:	AA190045
PARTS NO.:	RF151032
Tested By:	Wei Li
Temperature:	70°F
Humidity:	30%

Section:	Spurious Emissions at RF Output Port:
Plot Name:	Downlink, Inter-modulation
Configuration:	Input: Digital; Output: TX1 RF Output TM 32 5MHz Carrier BW, Hi freq

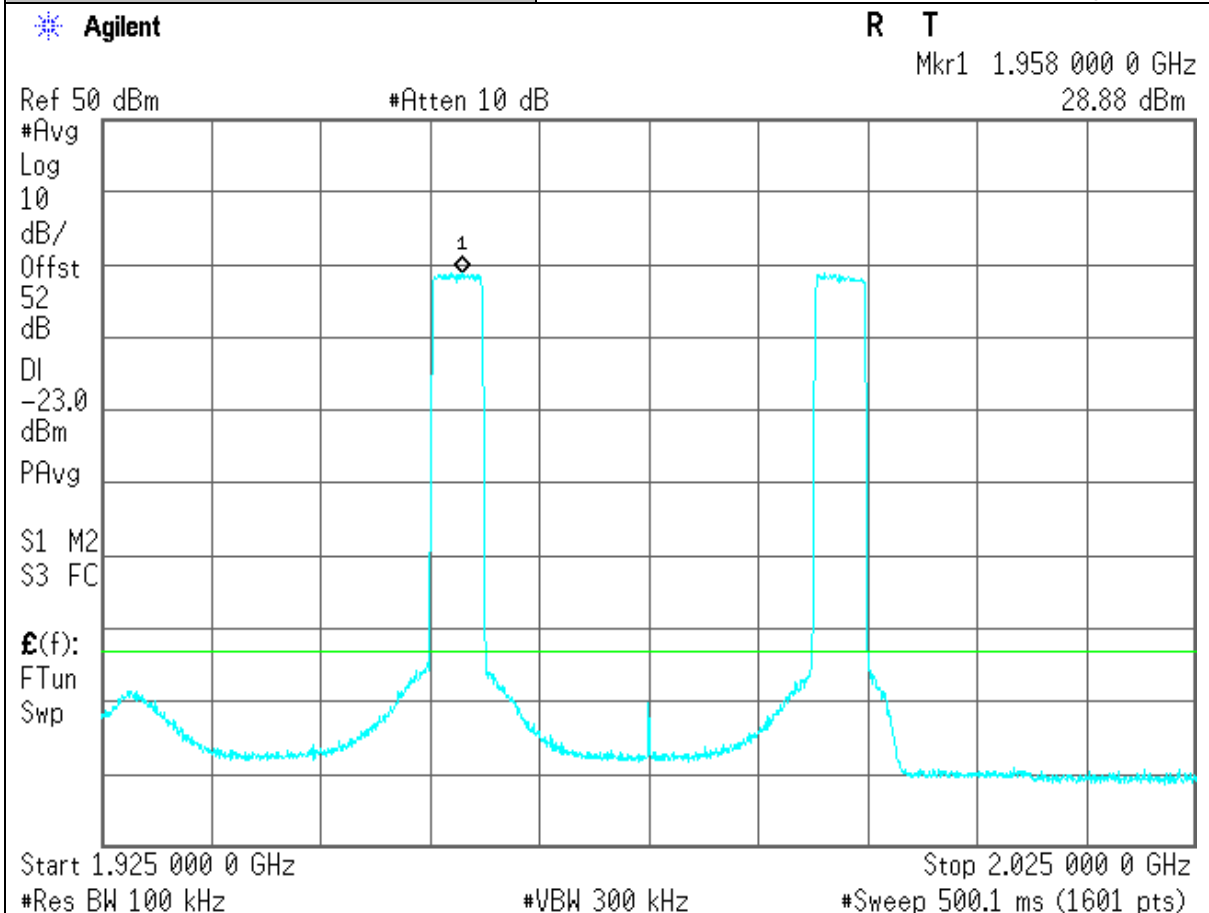

Project Number:	0048-130617-01
EUT:	AA190045
PARTS NO.:	RF151032
Tested By:	Wei Li
Temperature:	70°F
Humidity:	30%

Section:	Spurious Emissions at RF Output Port:
Plot Name:	Downlink, Inter-modulation
Configuration:	Input: Digital; Output: TX1 RF Output TM 32 10MHz Carrier BW, Low freq

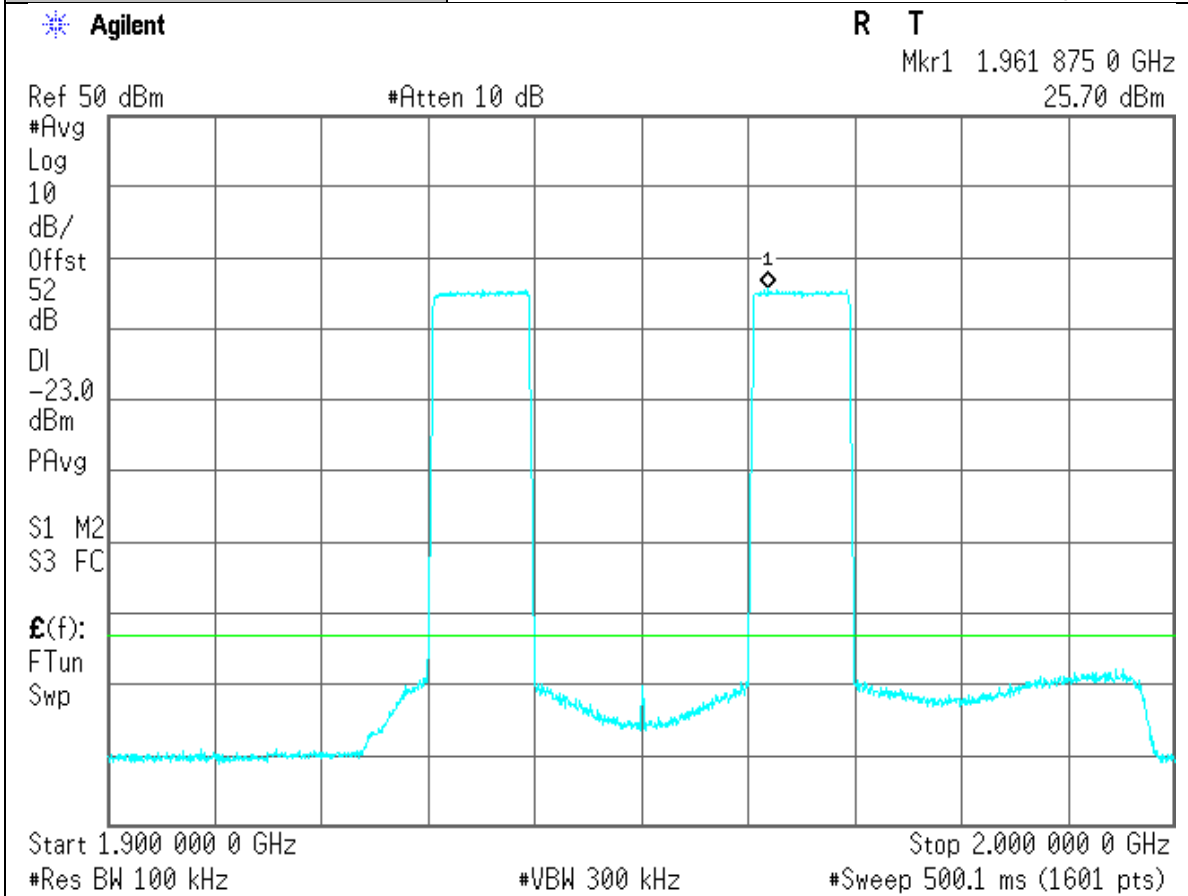

Project Number:	0048-130617-01
EUT:	AA190045
PARTS NO.:	RF151032
Tested By:	Wei Li
Temperature:	70°F
Humidity:	30%

Section:	Spurious Emissions at RF Output Port:
Plot Name:	Downlink, Inter-modulation
Configuration:	Input: Digital; Output: TX1 RF Output TM 32 10MHz Carrier BW, Mid freq

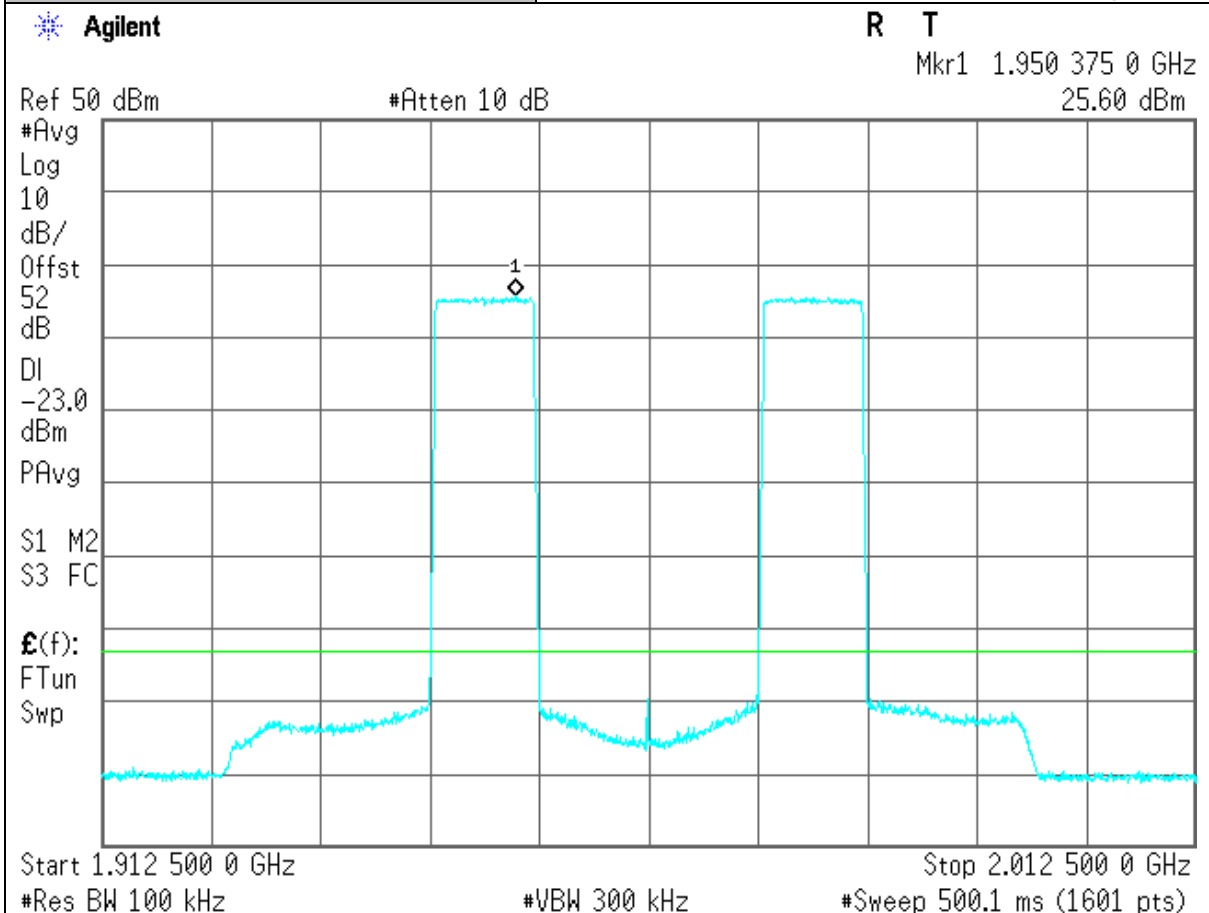

Project Number:	0048-130617-01
EUT:	AA190045
PARTS NO.:	RF151032
Tested By:	Wei Li
Temperature:	70°F
Humidity:	30%

Section:	Spurious Emissions at RF Output Port:
Plot Name:	Downlink, Inter-modulation
Configuration:	Input: Digital; Output: TX1 RF Output TM 32 10MHz Carrier BW, Hi freq

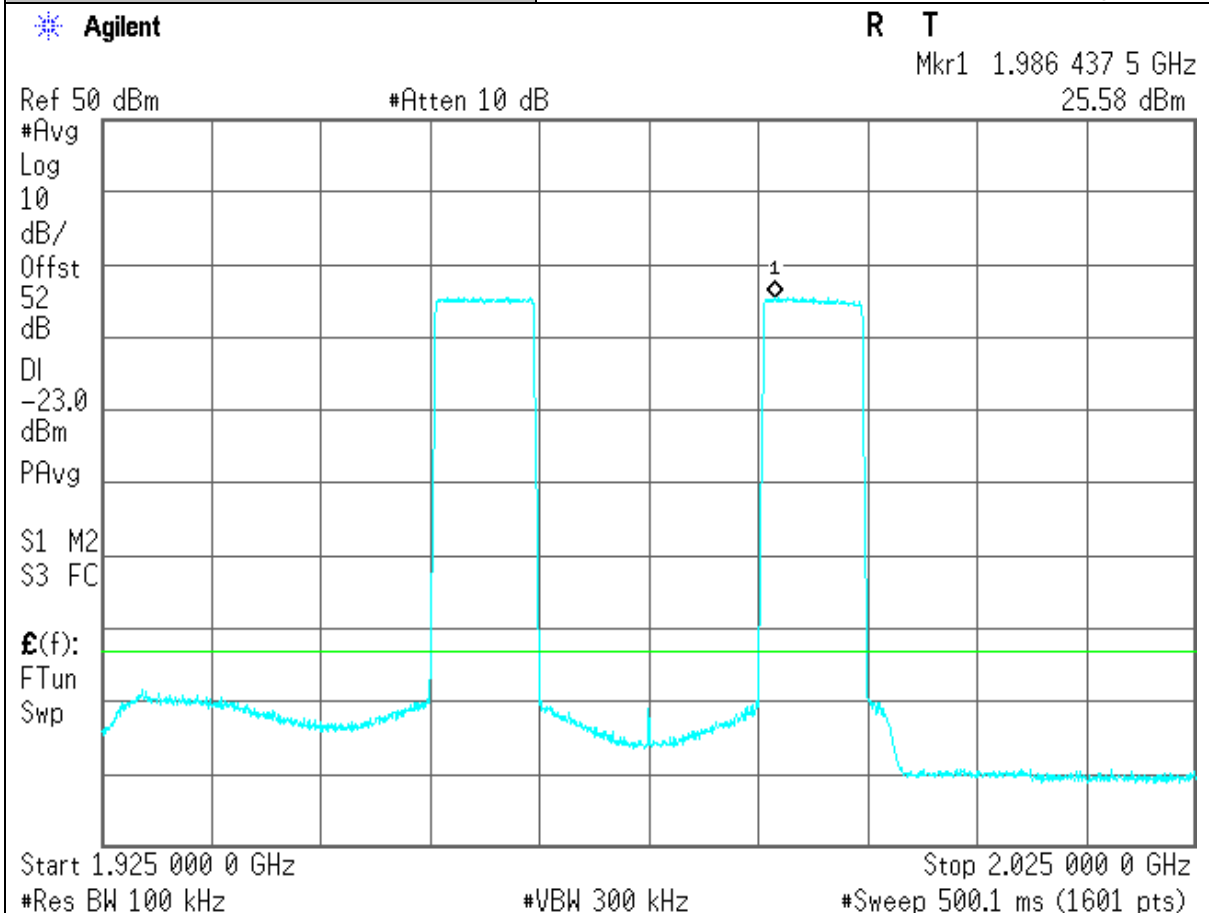

Project Number:	0048-130617-01
EUT:	AA190045
PARTS NO.:	RF151032
Tested By:	Wei Li
Temperature:	70°F
Humidity:	30%

Section:	Spurious Emissions at RF Output Port:
Plot Name:	Downlink, Inter-modulation
Configuration:	Input: Digital; Output: TX1 RF Output TM 32 5MHz Carrier BW, Low freq Adjacent Channels

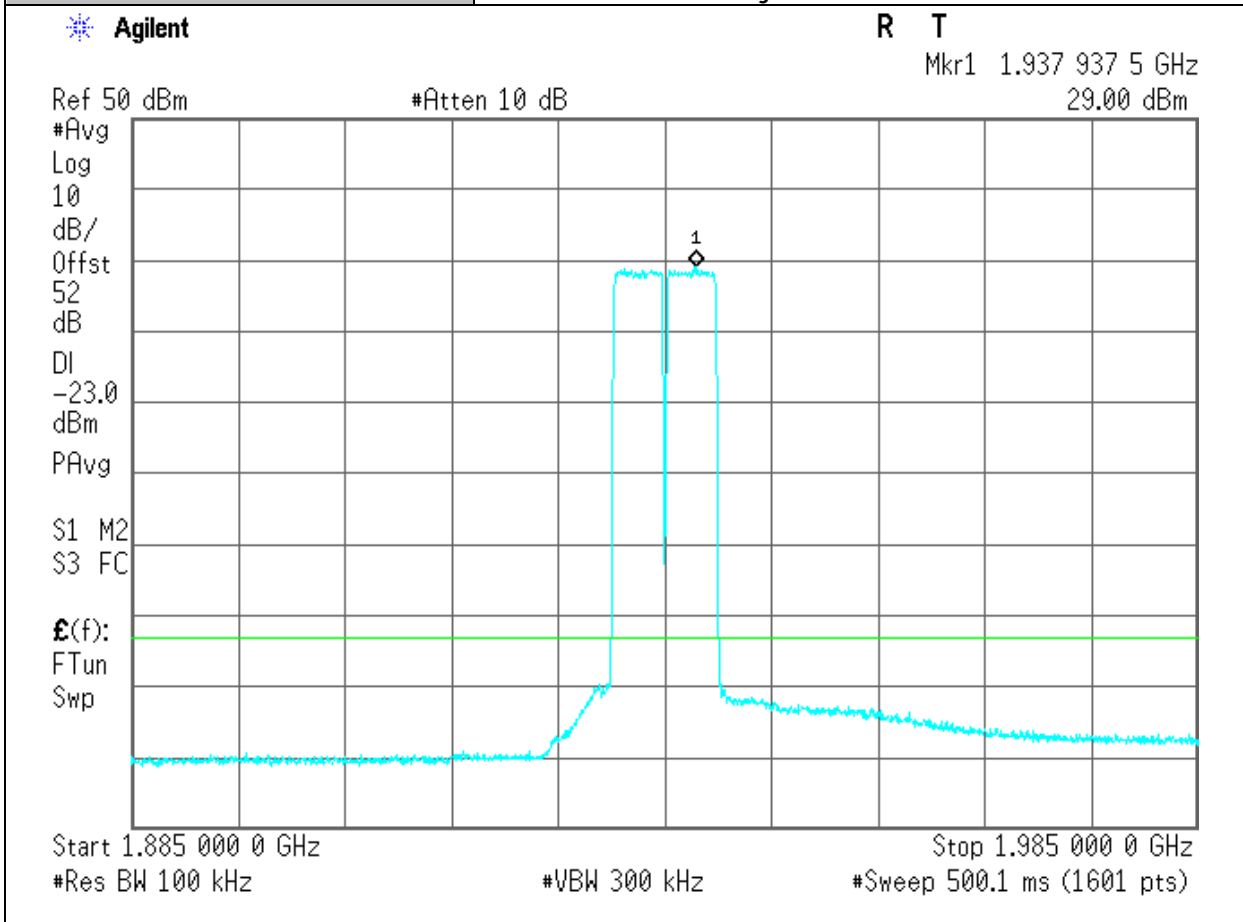

Project Number:	0048-130617-01
EUT:	AA190045
PARTS NO.:	RF151032
Tested By:	Wei Li
Temperature:	70°F
Humidity:	30%

Section:	Spurious Emissions at RF Output Port:
Plot Name:	Downlink, Inter-modulation
Configuration:	Input: Digital; Output: TX1 RF Output TM 32 5MHz Carrier BW, Mid freq Adjacent Channels

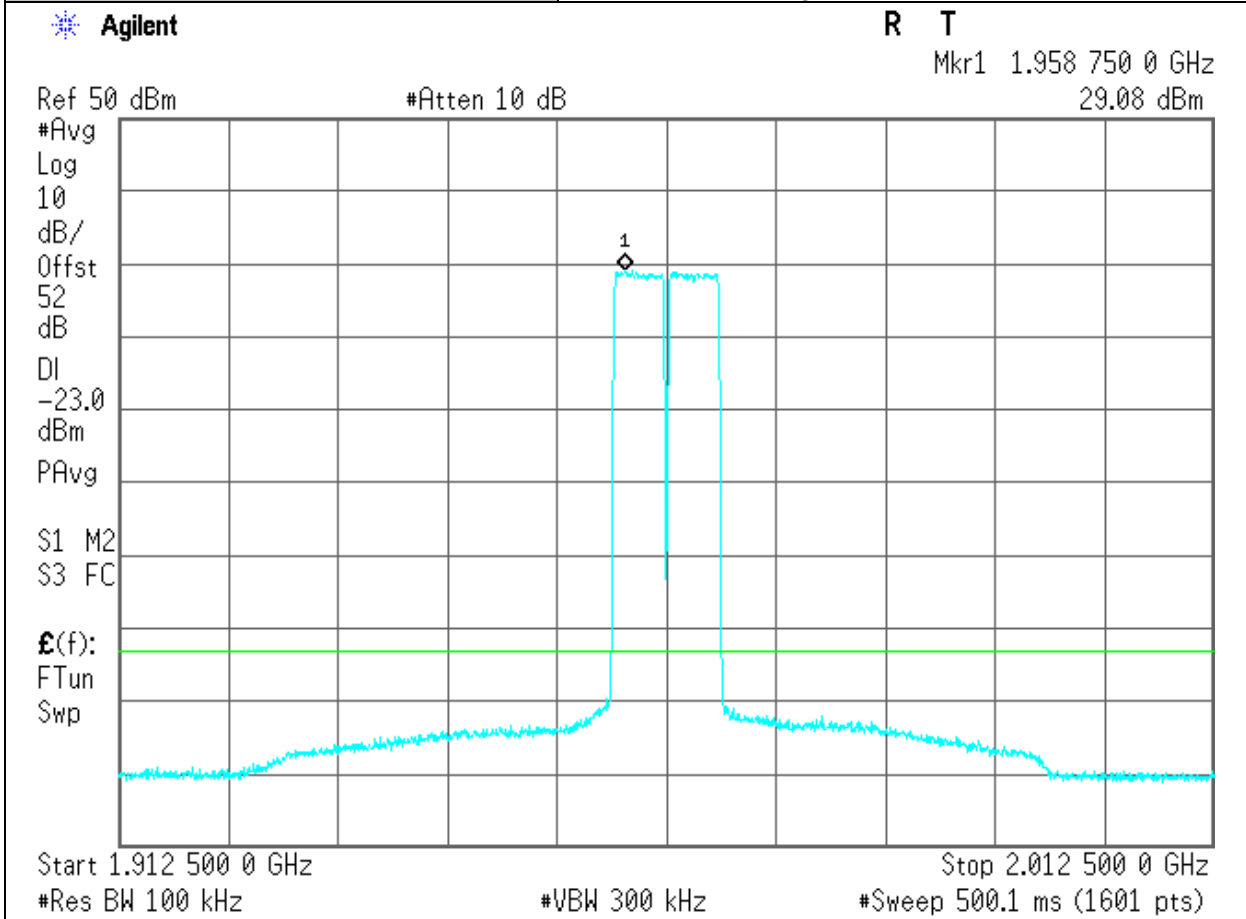

Project Number:	0048-130617-01
EUT:	AA190045
PARTS NO.:	RF151032
Tested By:	Wei Li
Temperature:	70°F
Humidity:	30%

Section:	Spurious Emissions at RF Output Port:
Plot Name:	Downlink, Inter-modulation
Configuration:	Input: Digital; Output: TX1 RF Output TM 32 5MHz Carrier BW, Hi freq Adjacent Channels

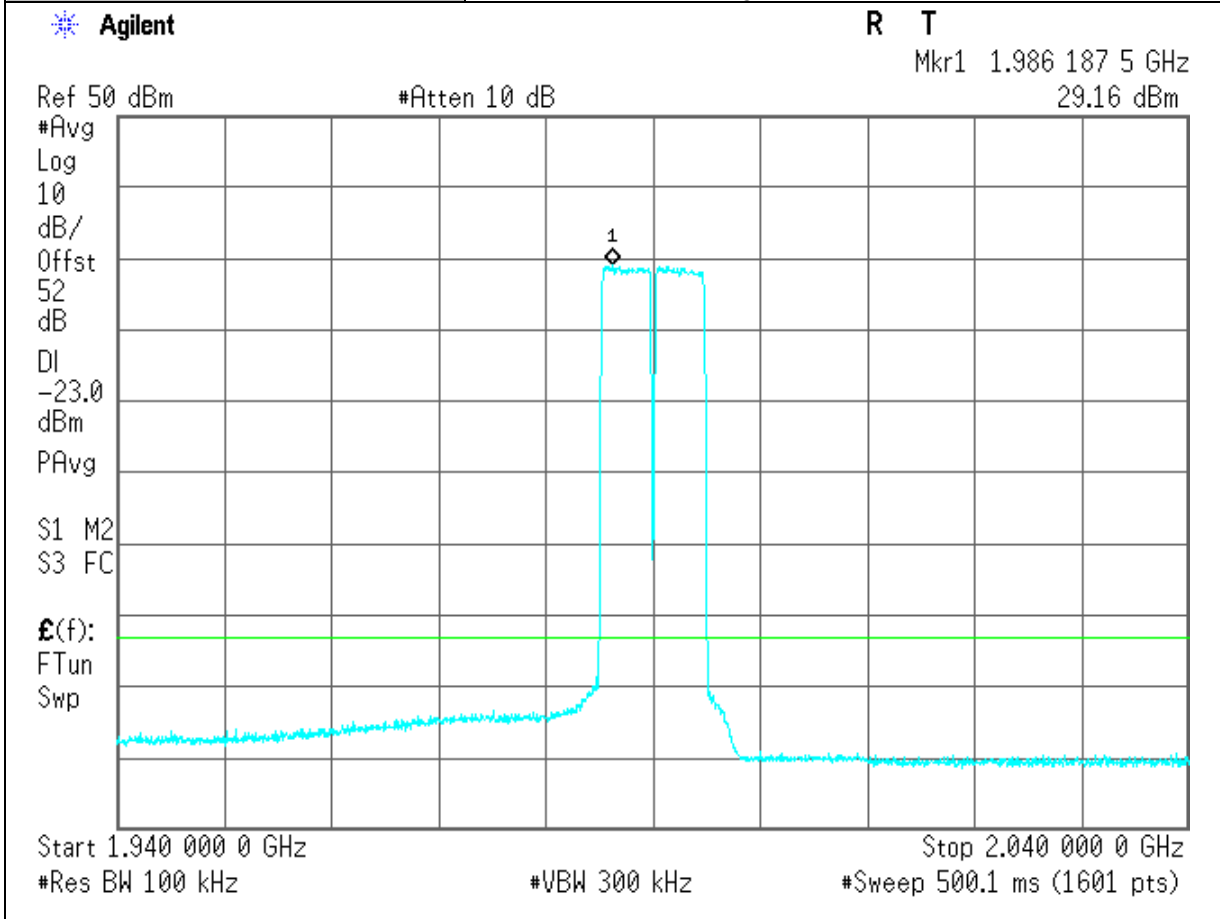

Project Number:	0048-130617-01
EUT:	AA190045
PARTS NO.:	RF151032
Tested By:	Wei Li
Temperature:	70°F
Humidity:	30%

Section:	Spurious Emissions at RF Output Port:
Plot Name:	Downlink, Inter-modulation
Configuration:	Input: Digital; Output: TX1 RF Output TM 32 10MHz Carrier BW, Low freq Adjacent Channels

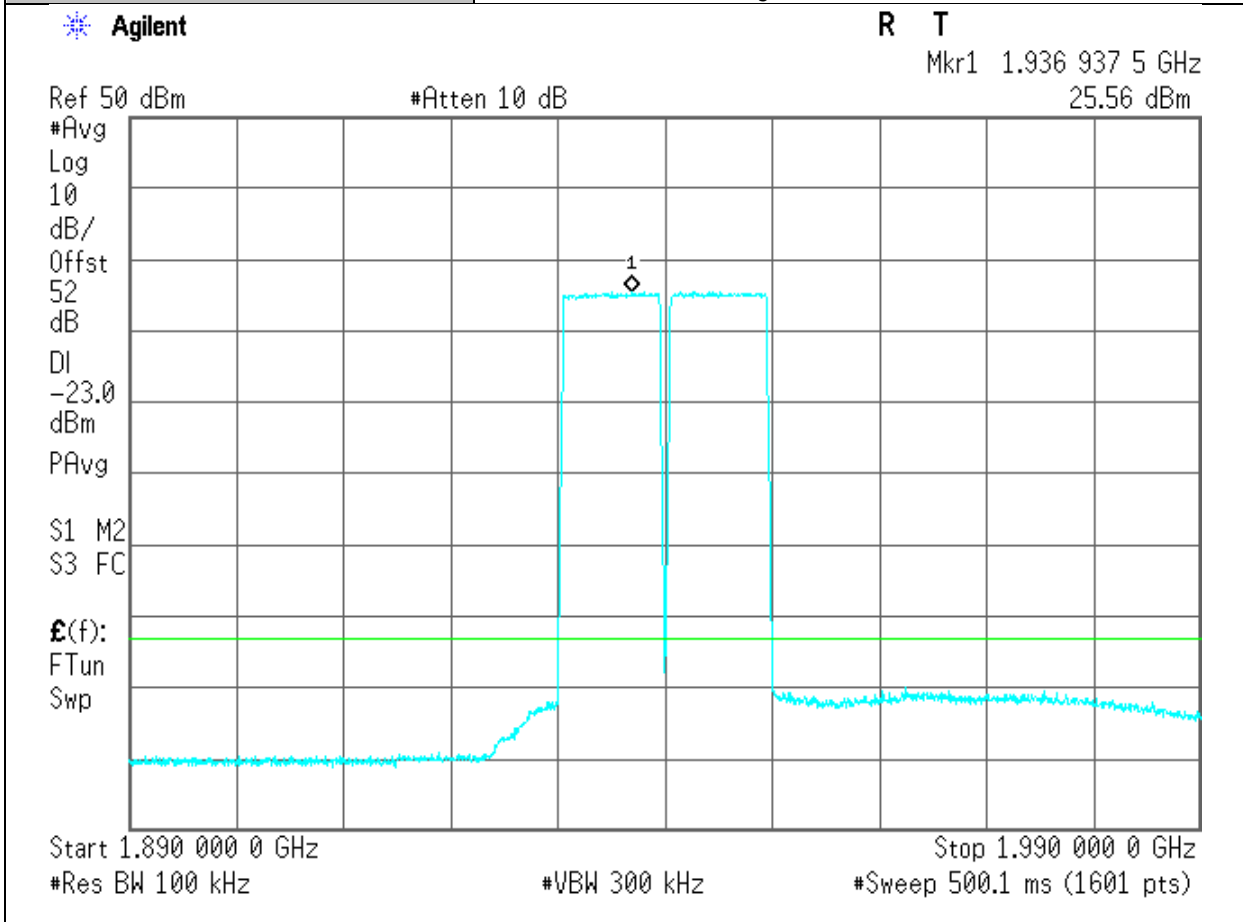

Project Number:	0048-130617-01
EUT:	AA190045
PARTS NO.:	RF151032
Tested By:	Wei Li
Temperature:	70°F
Humidity:	30%

Section:	Spurious Emissions at RF Output Port:
Plot Name:	Downlink, Inter-modulation
Configuration:	Input: Digital; Output: TX1 RF Output TM 32 10MHz Carrier BW, Mid freq Adjacent Channels

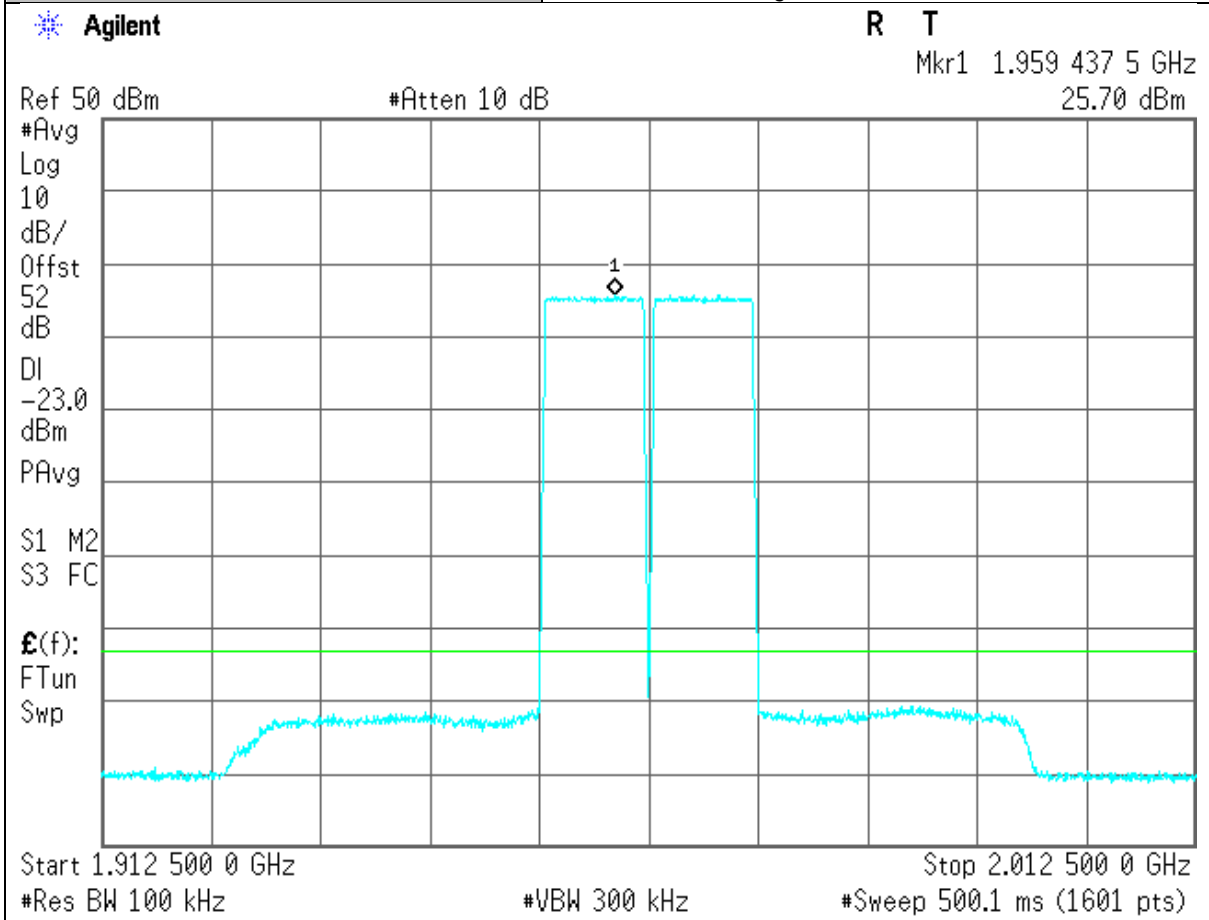

Project Number:	0048-130617-01
EUT:	AA190045
PARTS NO.:	RF151032
Tested By:	Wei Li
Temperature:	70°F
Humidity:	30%

Section:	Spurious Emissions at RF Output Port:
Plot Name:	Downlink, Low-Chn, Lower Bandedge
Configuration:	Input: Digital; Output: TX1 RF Output TM 11 5MHz Carrier

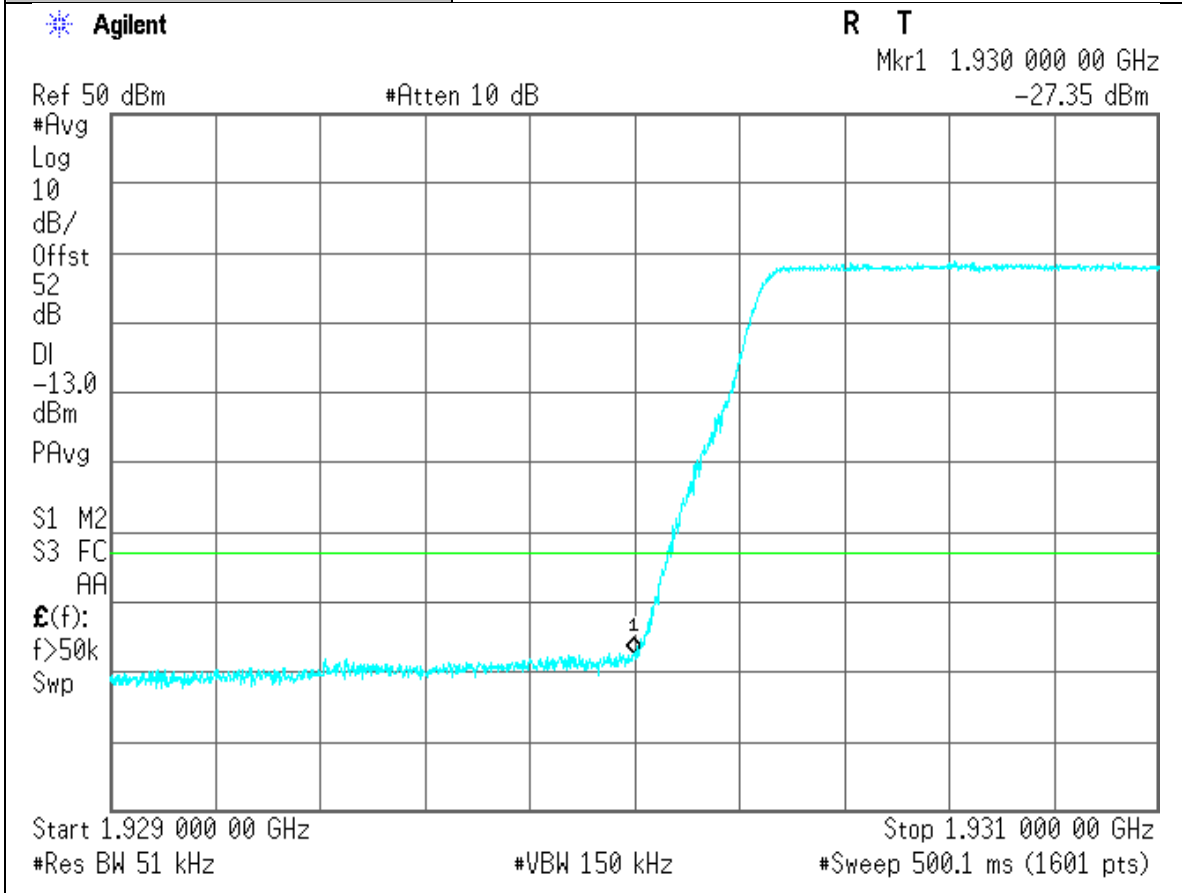

Project Number:	0048-130617-01
EUT:	AA190045
PARTS NO.:	RF151032
Tested By:	Wei Li
Temperature:	70°F
Humidity:	30%

Section:	Spurious Emissions at RF Output Port:
Plot Name:	Downlink, Low-Chn, Lower Bandedge
Configuration:	Input: Digital; Output: TX1 RF Output TM 11 5MHz Carrier

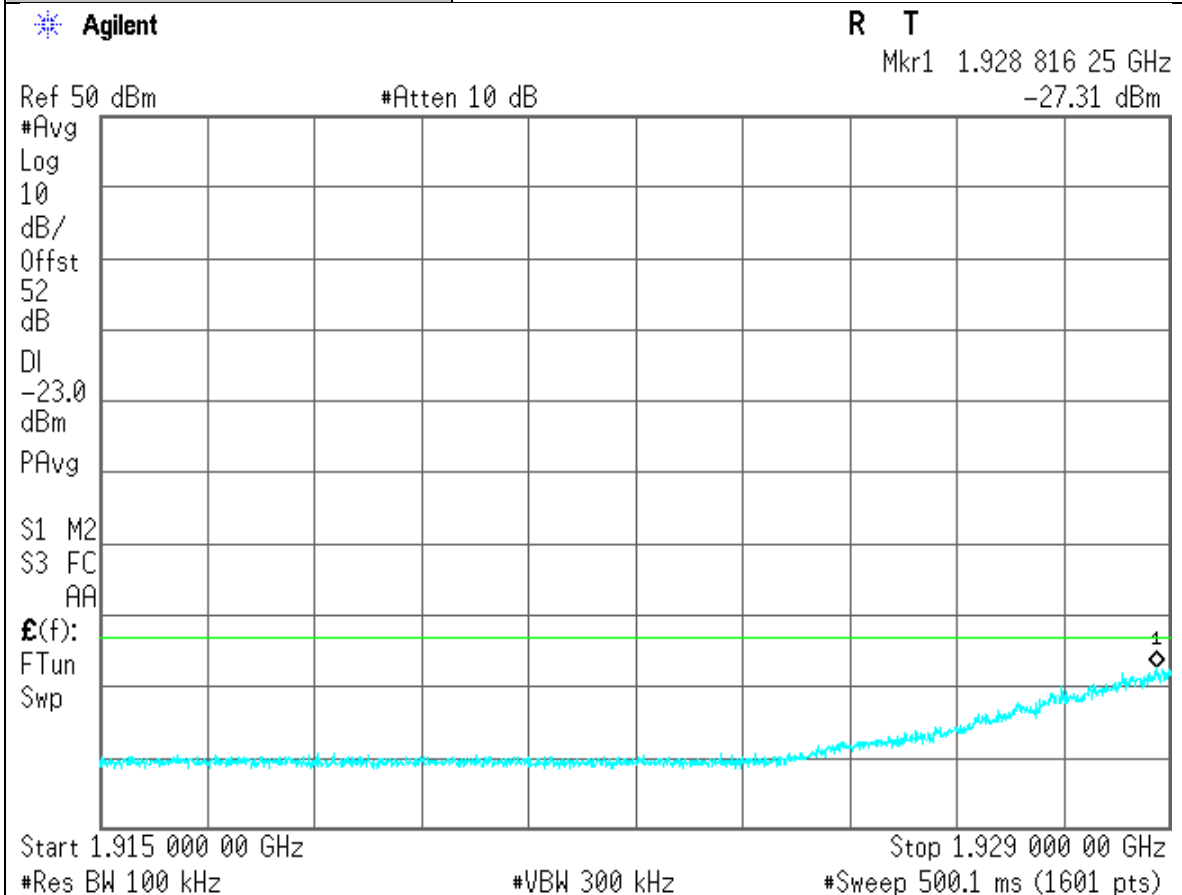

Project Number:	0048-130617-01
EUT:	AA190045
PARTS NO.:	RF151032
Tested By:	Wei Li
Temperature:	70°F
Humidity:	30%

Section:	Spurious Emissions at RF Output Port:
Plot Name:	Downlink, Hi-Chn, Upper Bandedge
Configuration:	Input: Digital; Output: TX1 RF Output TM 11 5MHz Carrier

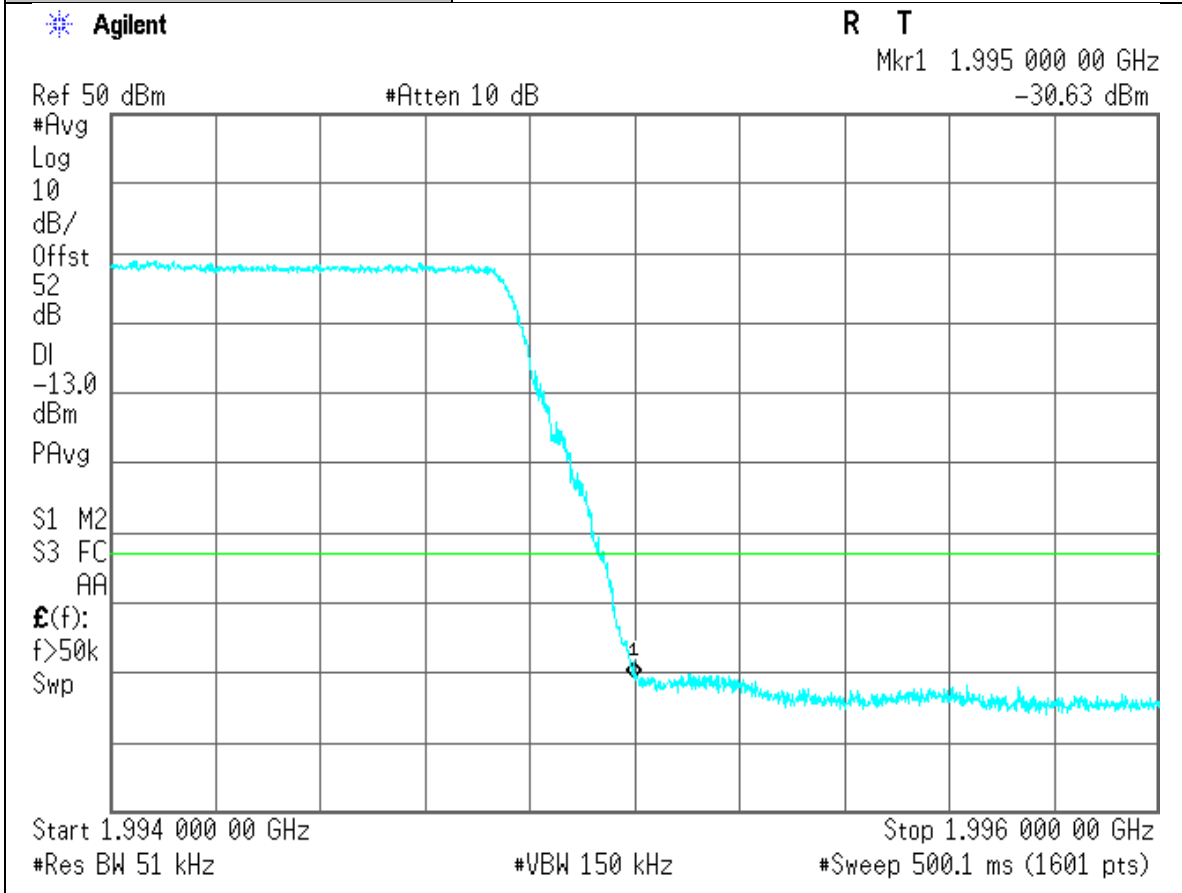

Project Number:	0048-130617-01
EUT:	AA190045
PARTS NO.:	RF151032
Tested By:	Wei Li
Temperature:	70°F
Humidity:	30%

Section:	Spurious Emissions at RF Output Port:
Plot Name:	Downlink, Hi-Chn, Upper Bandedge
Configuration:	Input: Digital; Output: TX1 RF Output TM 11 5MHz Carrier

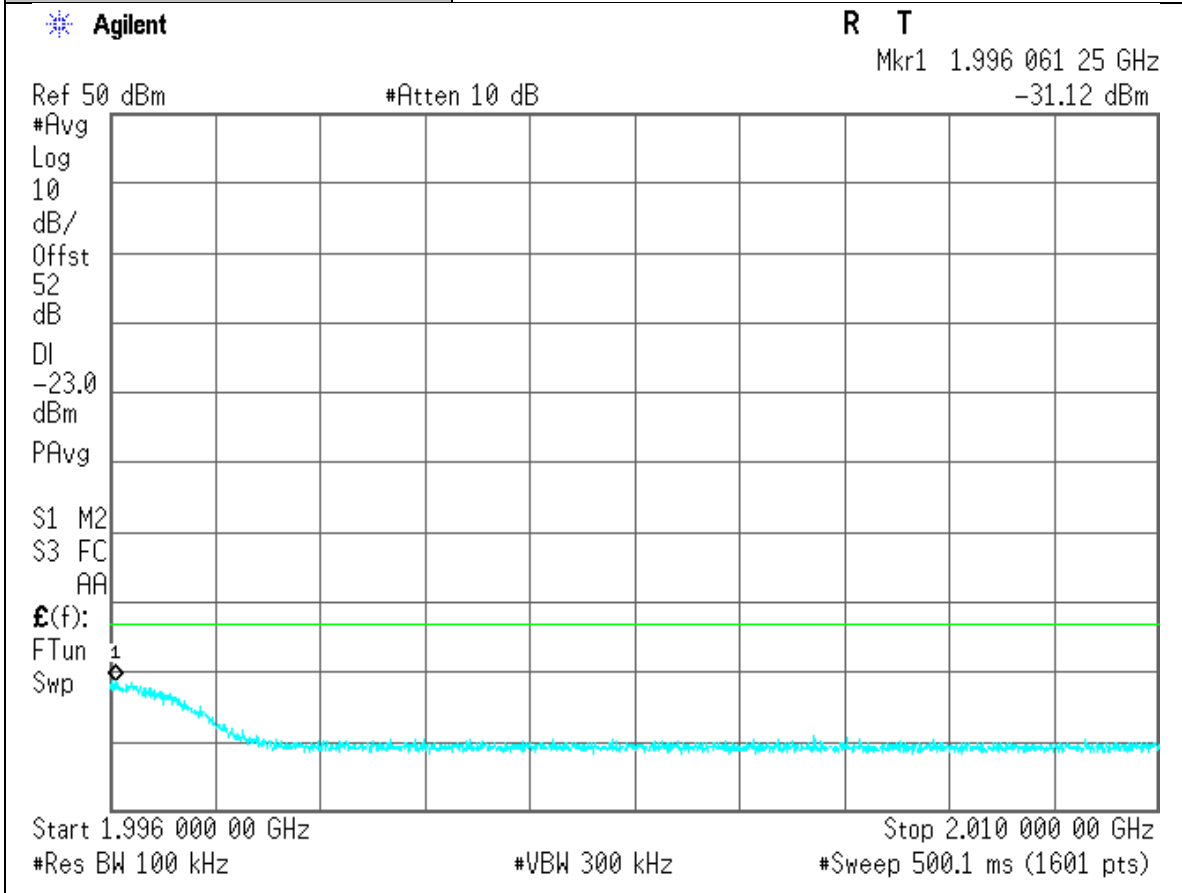

Project Number:	0048-130617-01
EUT:	AA190045
PARTS NO.:	RF151032
Tested By:	Wei Li
Temperature:	70°F
Humidity:	30%

Section:	Spurious Emissions at RF Output Port:
Plot Name:	Downlink, Low-Chn, Lower Bandedge
Configuration:	Input: Digital; Output: TX1 RF Output TM 11 5MHz Carriers

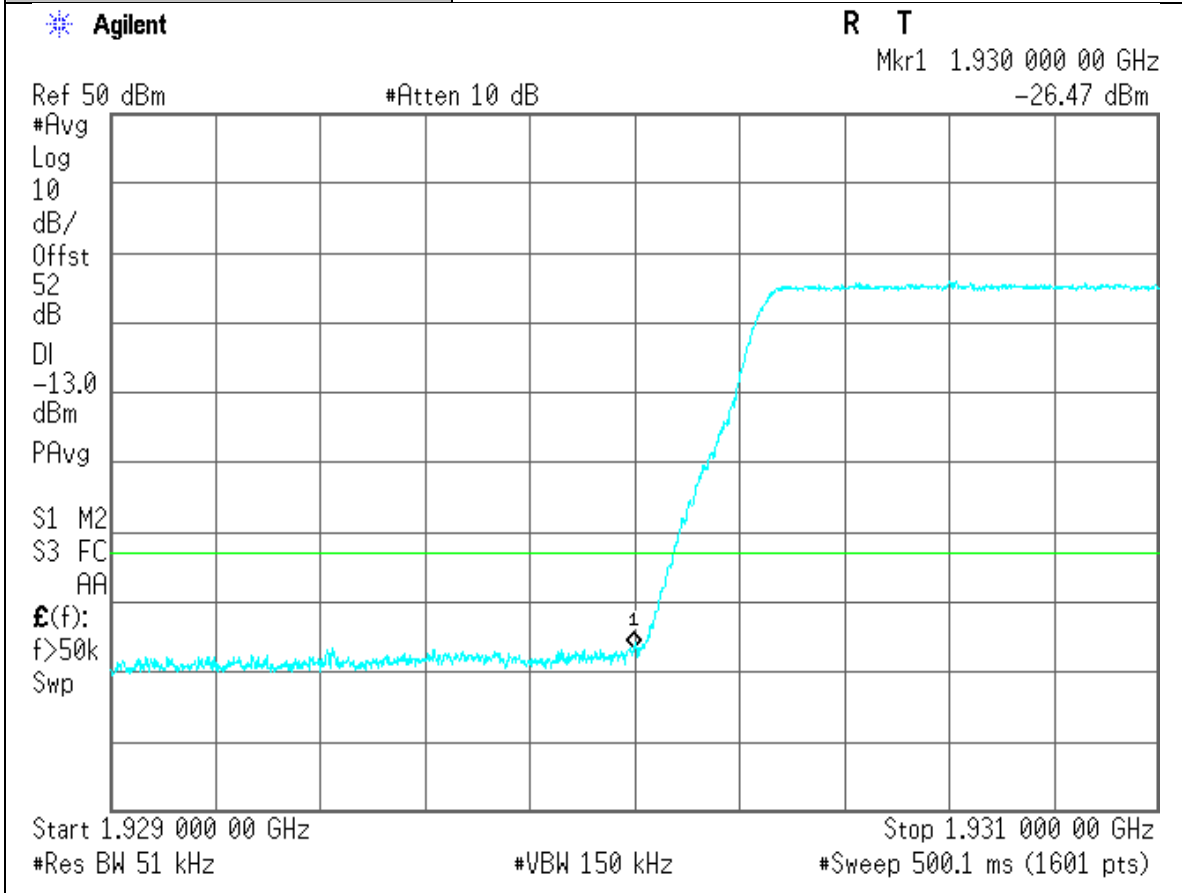

Project Number:	0048-130617-01
EUT:	AA190045
PARTS NO.:	RF151032
Tested By:	Wei Li
Temperature:	70°F
Humidity:	30%

Section:	Spurious Emissions at RF Output Port:
Plot Name:	Downlink, Low-Chn, Lower Bandedge
Configuration:	Input: Digital; Output: TX1 RF Output TM 11 5MHz Carriers

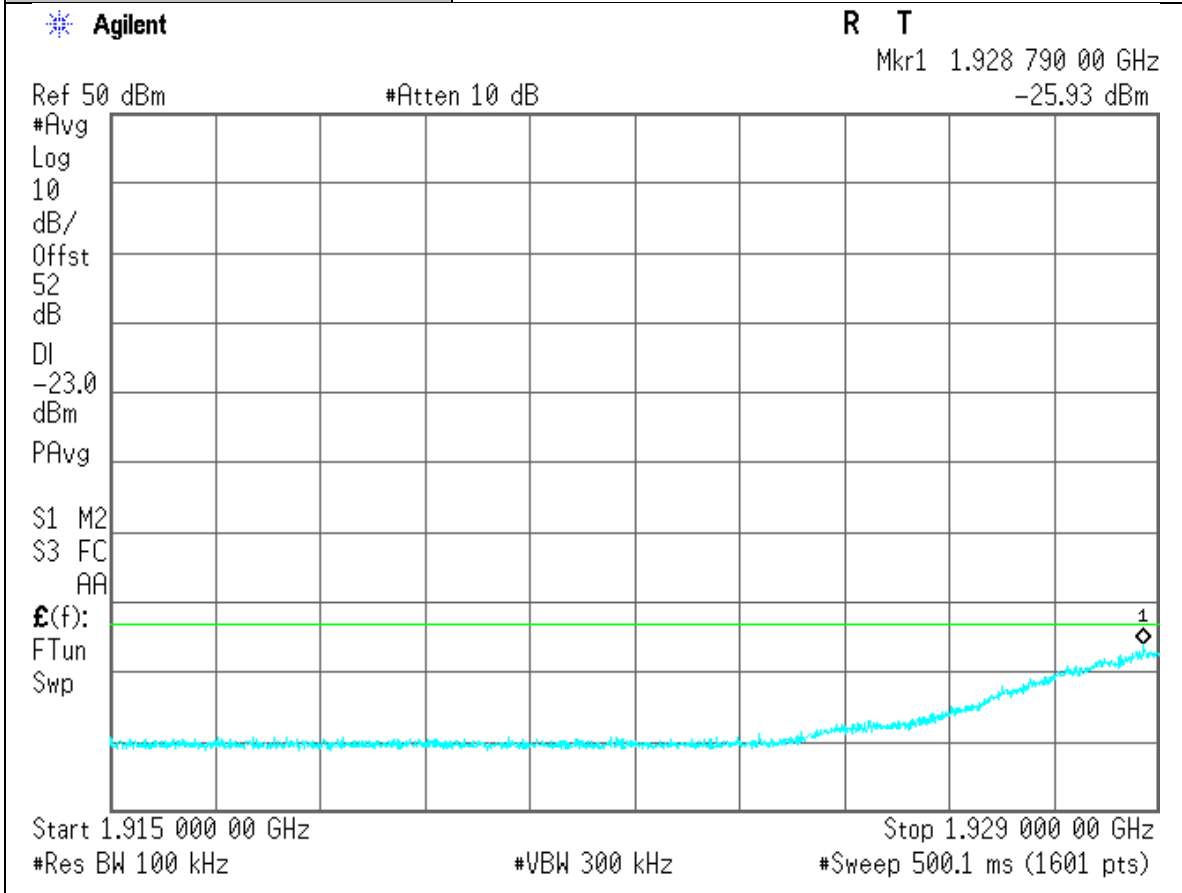

Project Number:	0048-130617-01
EUT:	AA190045
PARTS NO.:	RF151032
Tested By:	Wei Li
Temperature:	70°F
Humidity:	30%

Section:	Spurious Emissions at RF Output Port:
Plot Name:	Downlink, Hi-Chn, Upper Bandedge
Configuration:	Input: Digital; Output: TX1 RF Output TM 11 5MHz Carriers

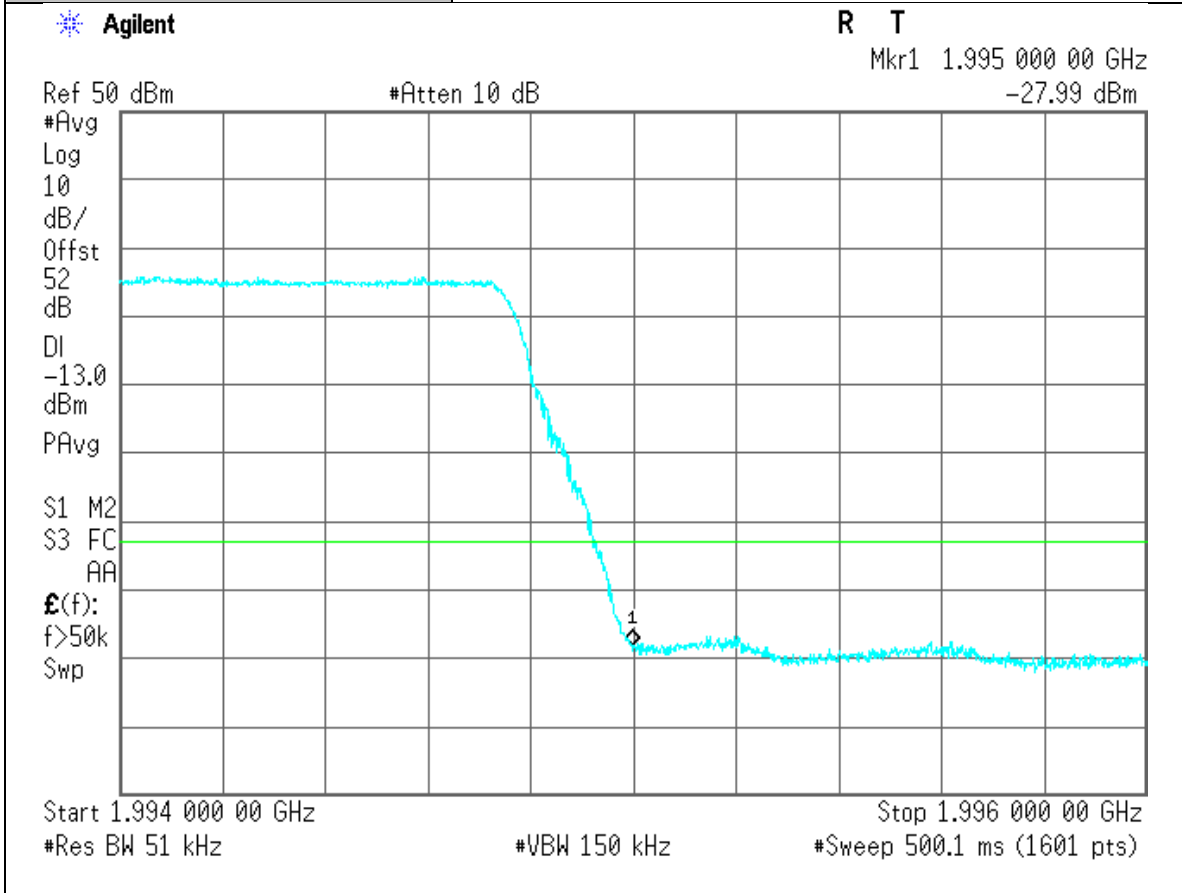

Project Number:	0048-130617-01
EUT:	AA190045
PARTS NO.:	RF151032
Tested By:	Wei Li
Temperature:	70°F
Humidity:	30%

Section:	Spurious Emissions at RF Output Port:
Plot Name:	Downlink, Hi-Chn, Upper Bandedge
Configuration:	Input: Digital; Output: TX1 RF Output TM 11 5MHz Carriers

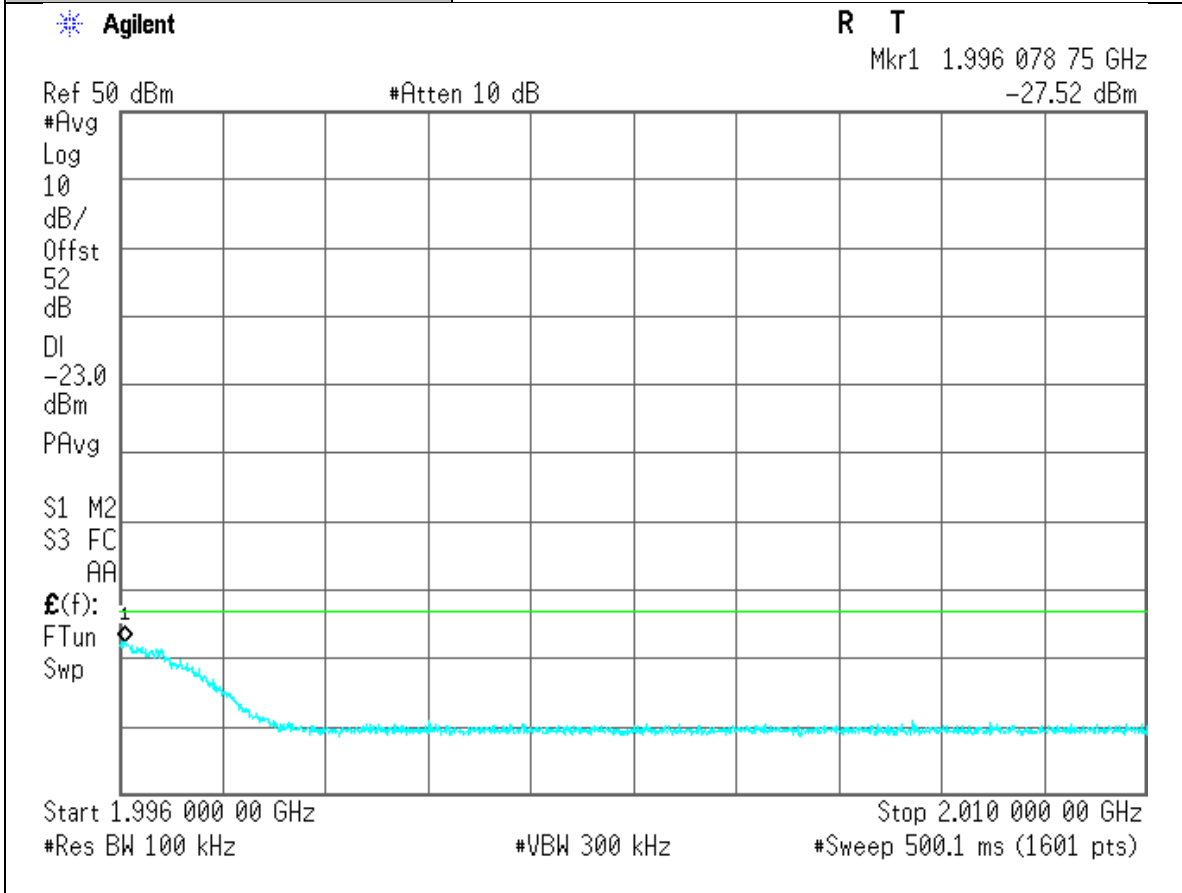

Project Number:	0048-130617-01
EUT:	AA190045
PARTS NO.:	RF151032
Tested By:	Wei Li
Temperature:	70°F
Humidity:	30%

Section:	Spurious Emissions at RF Output Port:
Plot Name:	Downlink, Low-Chn, Lower Bandedge
Configuration:	Input: Digital; Output: TX1 RF Output TM 31 5MHz Carrier

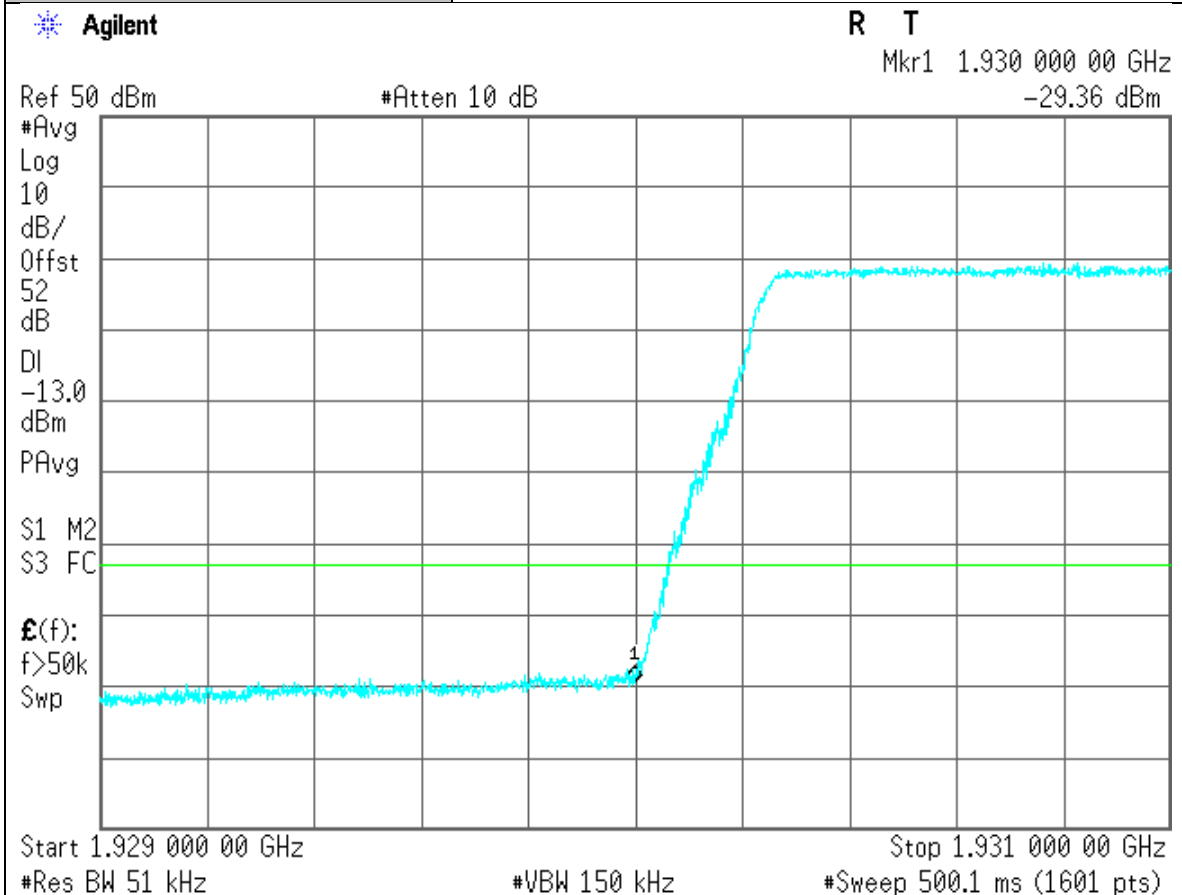

Project Number:	0048-130617-01
EUT:	AA190045
PARTS NO.:	RF151032
Tested By:	Wei Li
Temperature:	70°F
Humidity:	30%

Section:	Spurious Emissions at RF Output Port:
Plot Name:	Downlink, Low-Chn, Lower Bandedge
Configuration:	Input: Digital; Output: TX1 RF Output TM 31 5MHz Carrier

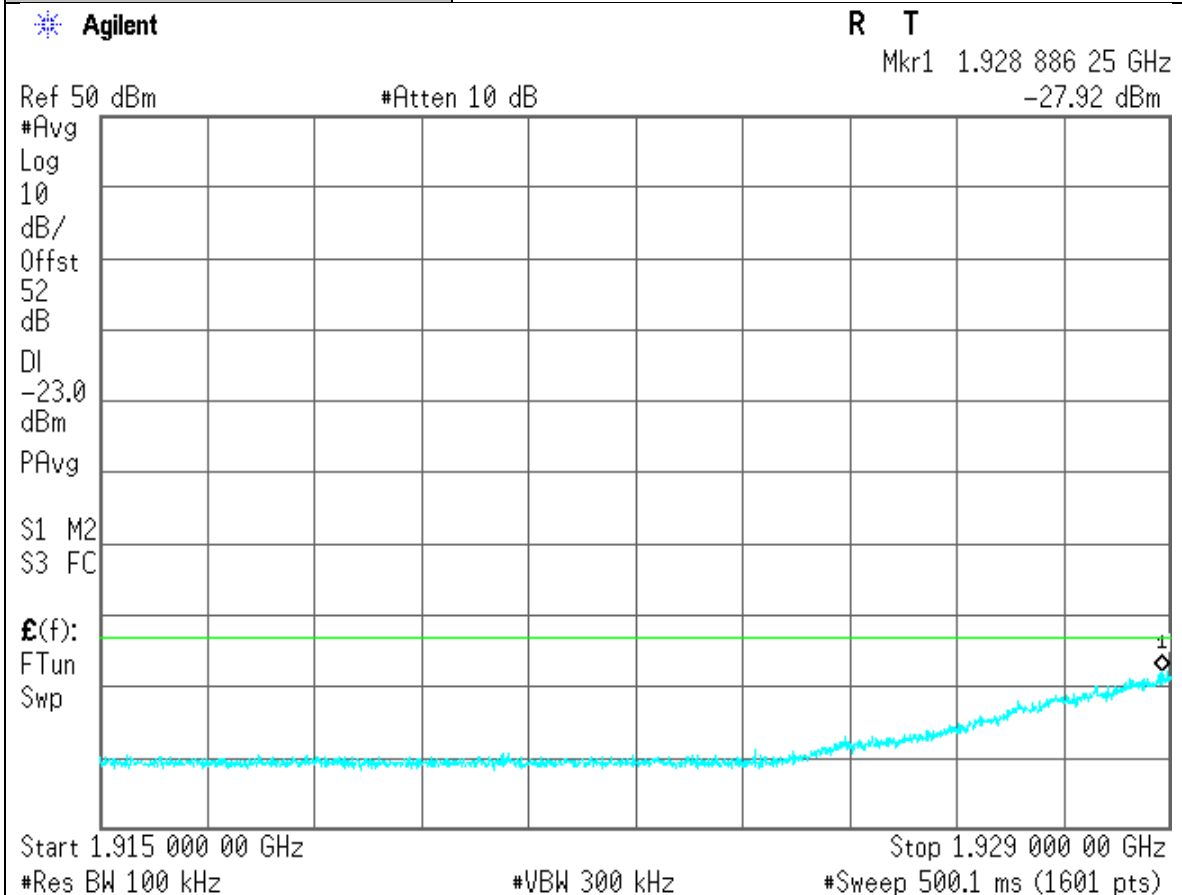

Project Number:	0048-130617-01
EUT:	AA190045
PARTS NO.:	RF151032
Tested By:	Wei Li
Temperature:	70°F
Humidity:	30%

Section:	Spurious Emissions at RF Output Port:
Plot Name:	Downlink, Hi-Chn, Upper Bandedge
Configuration:	Input: Digital; Output: TX1 RF Output TM 31 5MHz Carrier

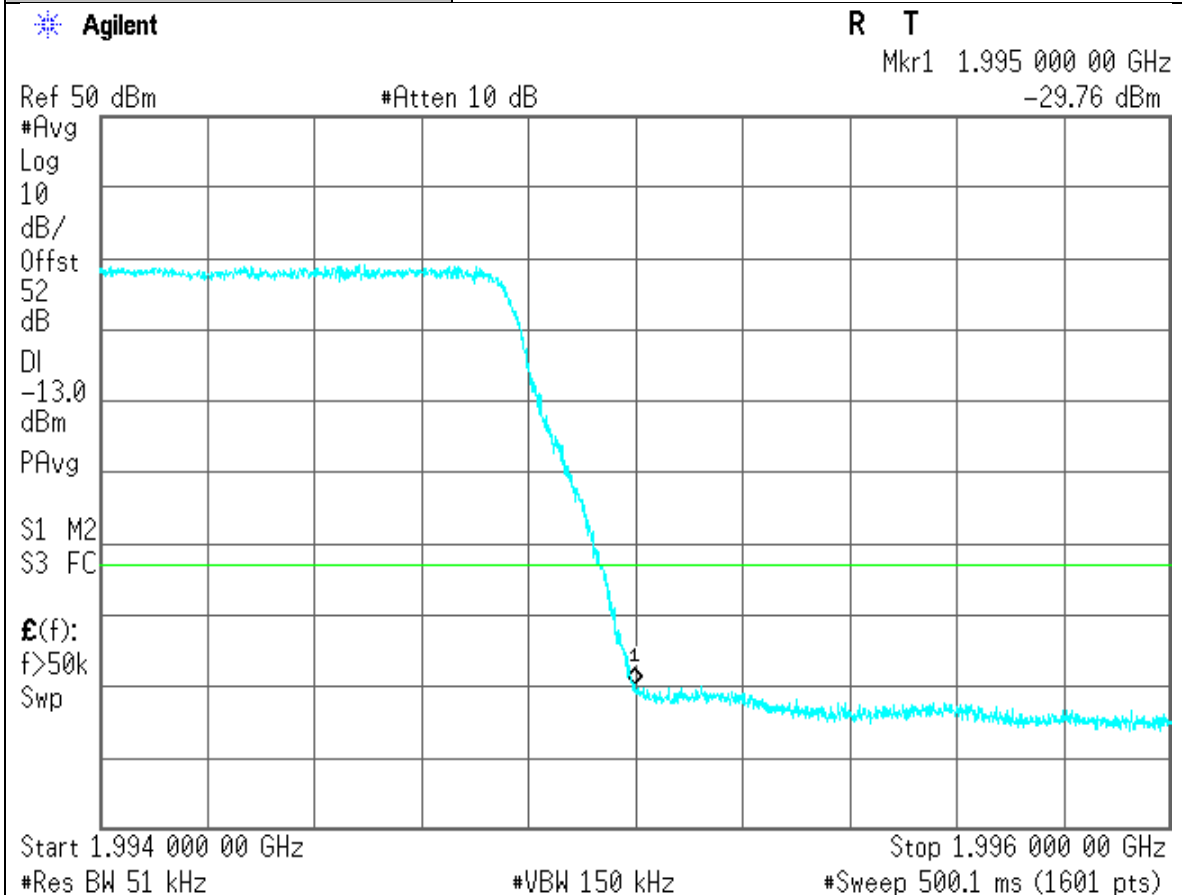

Project Number:	0048-130617-01
EUT:	AA190045
PARTS NO.:	RF151032
Tested By:	Wei Li
Temperature:	70°F
Humidity:	30%

Section:	Spurious Emissions at RF Output Port:
Plot Name:	Downlink, Hi-Chn, Upper Bandedge
Configuration:	Input: Digital; Output: TX1 RF Output TM 31 5MHz Carrier

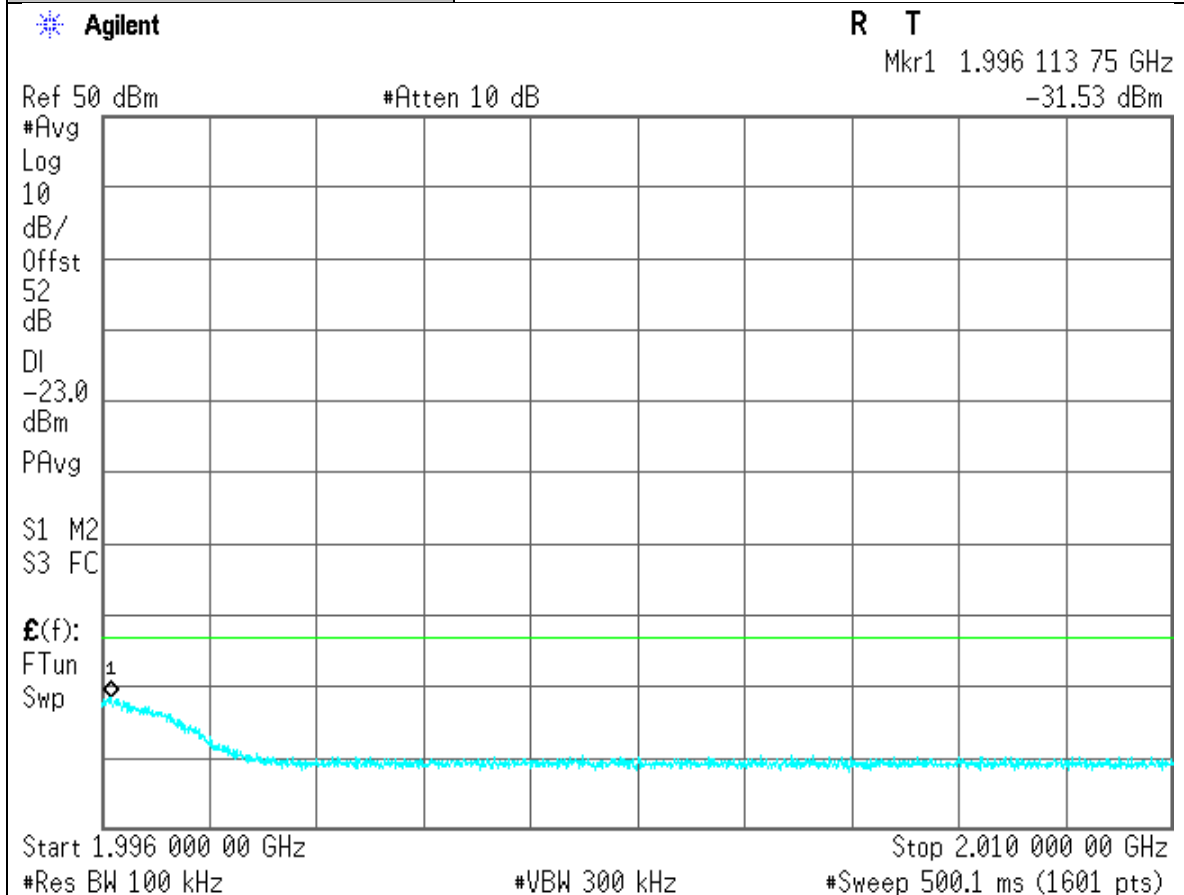

Project Number:	0048-130617-01
EUT:	AA190045
PARTS NO.:	RF151032
Tested By:	Wei Li
Temperature:	70°F
Humidity:	30%

Section:	Spurious Emissions at RF Output Port:
Plot Name:	Downlink, Low-Chn, Lower Bandedge
Configuration:	Input: Digital; Output: TX1 RF Output TM 31 5MHz Carriers

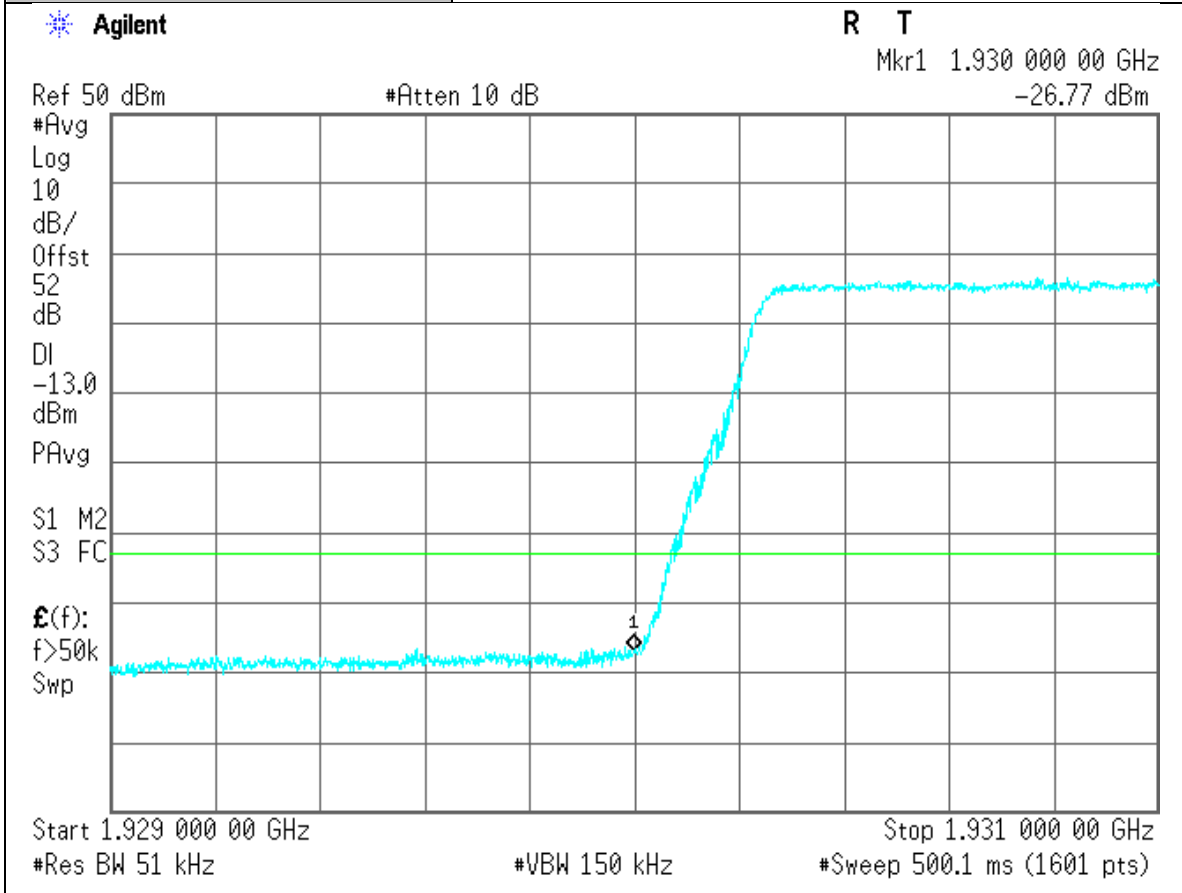

Project Number:	0048-130617-01
EUT:	AA190045
PARTS NO.:	RF151032
Tested By:	Wei Li
Temperature:	70°F
Humidity:	30%

Section:	Spurious Emissions at RF Output Port:
Plot Name:	Downlink, Low-Chn, Lower Bandedge
Configuration:	Input: Digital; Output: TX1 RF Output TM 31 5MHz Carriers

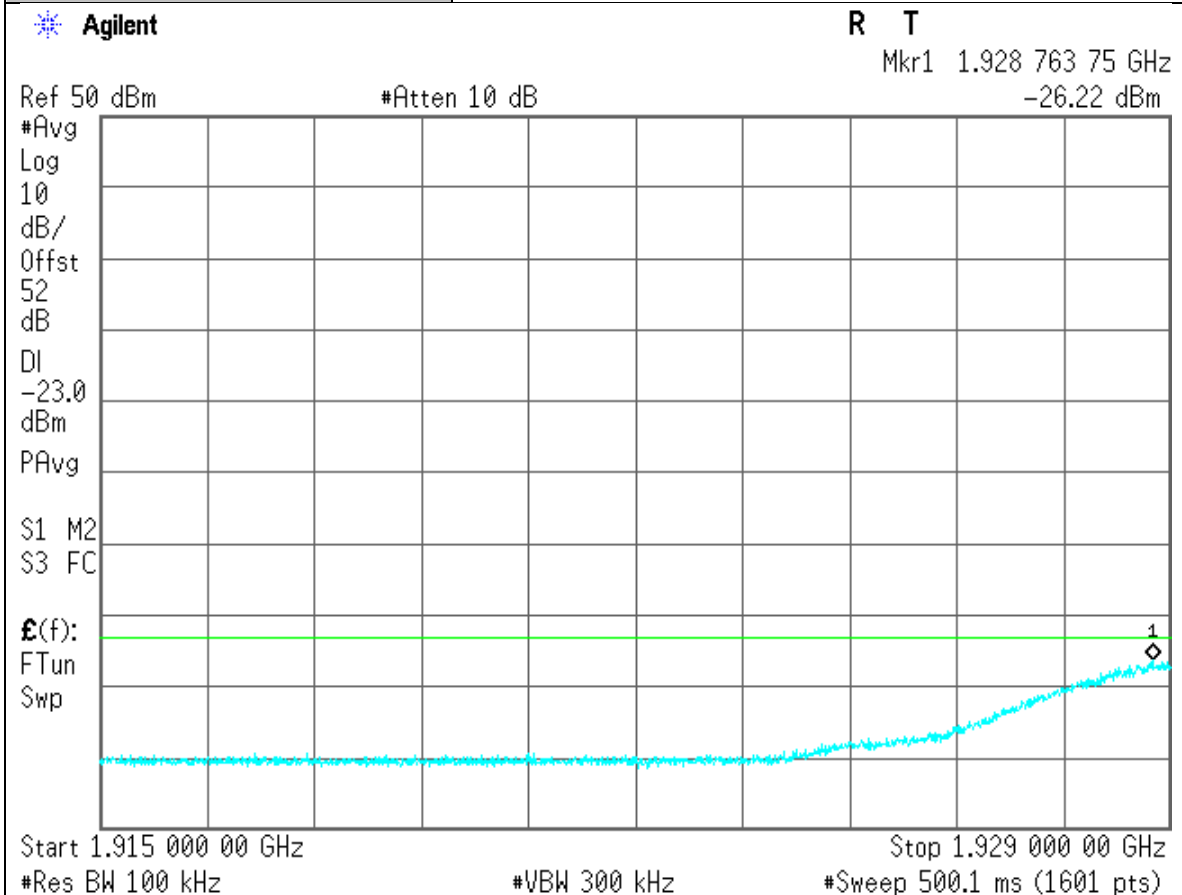

Project Number:	0048-130617-01
EUT:	AA190045
PARTS NO.:	RF151032
Tested By:	Wei Li
Temperature:	70°F
Humidity:	30%

Section:	Spurious Emissions at RF Output Port:
Plot Name:	Downlink, Hi-Chn, Upper Bandedge
Configuration:	Input: Digital; Output: TX1 RF Output TM 31 5MHz Carriers

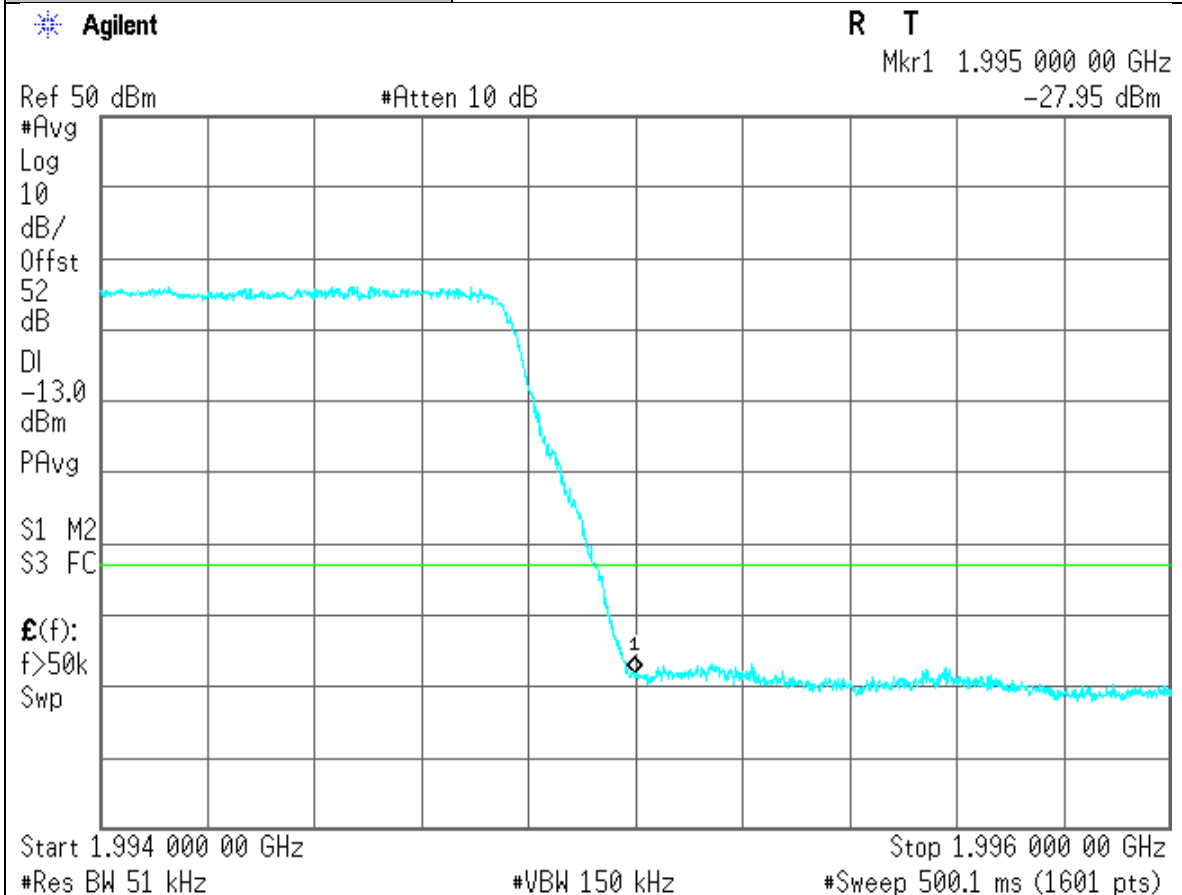

Project Number:	0048-130617-01
EUT:	AA190045
PARTS NO.:	RF151032
Tested By:	Wei Li
Temperature:	70°F
Humidity:	30%

Section:	Spurious Emissions at RF Output Port:
Plot Name:	Downlink, Hi-Chn, Upper Bandedge
Configuration:	Input: Digital; Output: TX1 RF Output TM 31 5MHz Carriers

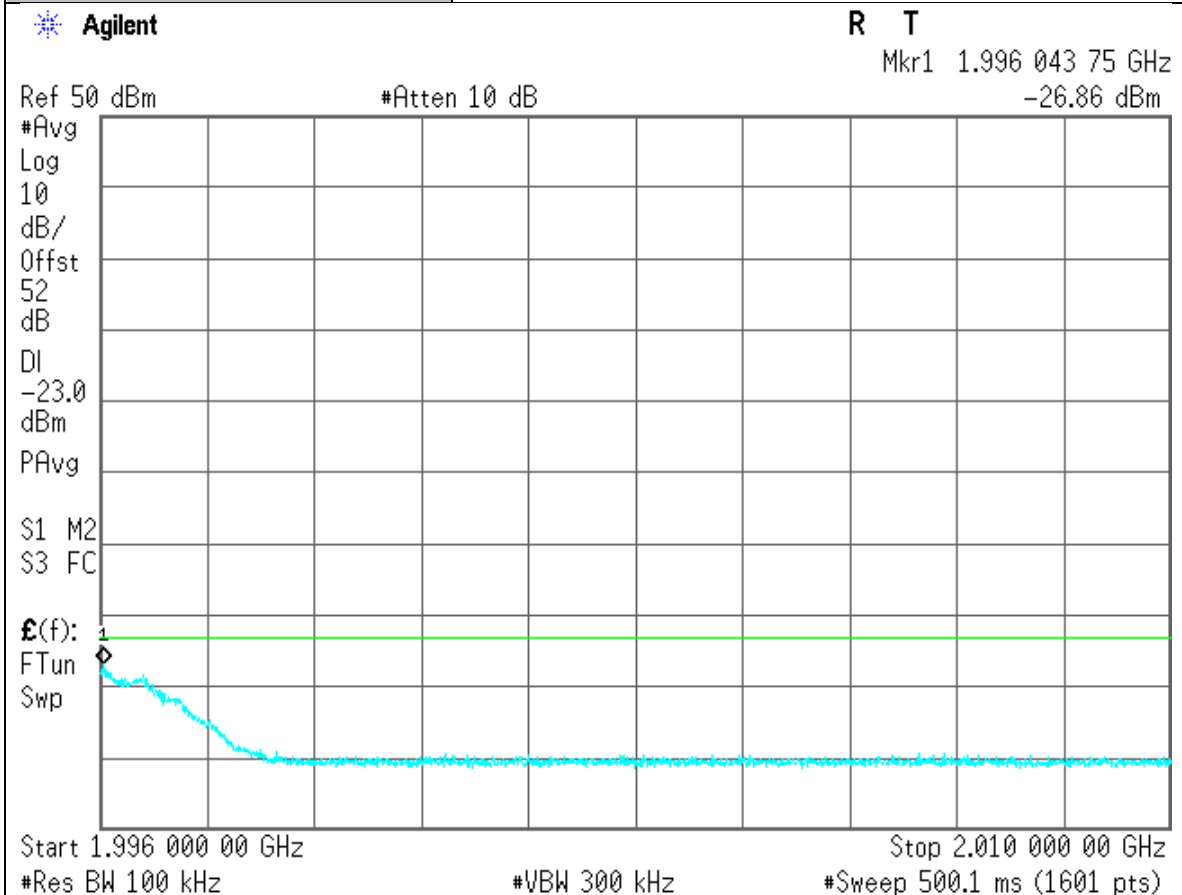

Project Number:	0048-130617-01
EUT:	AA190045
PARTS NO.:	RF151032
Tested By:	Wei Li
Temperature:	70°F
Humidity:	30%

Section:	Spurious Emissions at RF Output Port:
Plot Name:	Downlink, Low-Chn, Lower Bandedge
Configuration:	Input: Digital; Output: TX1 RF Output TM 32 5MHz Carrier

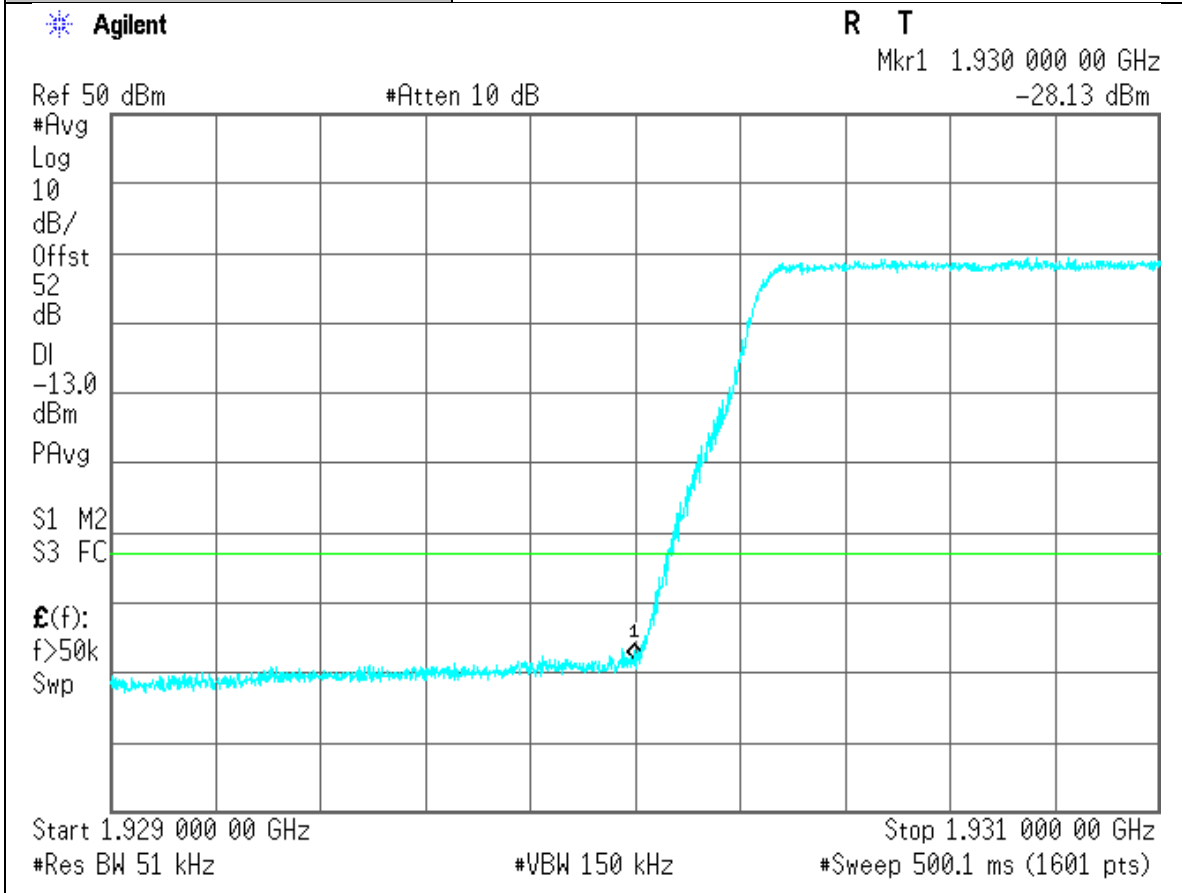

Project Number:	0048-130617-01
EUT:	AA190045
PARTS NO.:	RF151032
Tested By:	Wei Li
Temperature:	70°F
Humidity:	30%

Section:	Spurious Emissions at RF Output Port:
Plot Name:	Downlink, Low-Chn, Lower Bandedge
Configuration:	Input: Digital; Output: TX1 RF Output TM 32 5MHz Carrier

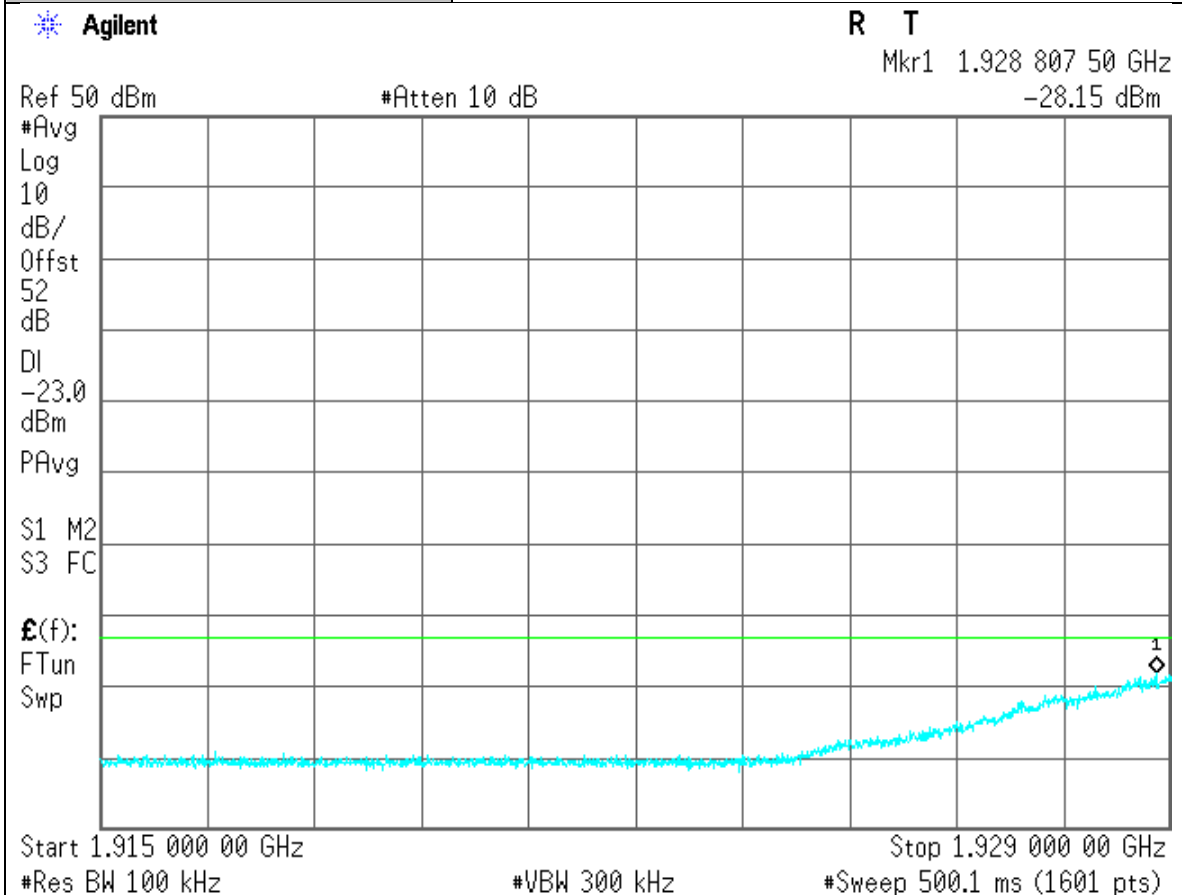

Project Number:	0048-130617-01
EUT:	AA190045
PARTS NO.:	RF151032
Tested By:	Wei Li
Temperature:	70°F
Humidity:	30%

Section:	Spurious Emissions at RF Output Port:
Plot Name:	Downlink, Hi-Chn, Upper Bandedge
Configuration:	Input: Digital; Output: TX1 RF Output TM 32 5MHz Carrier

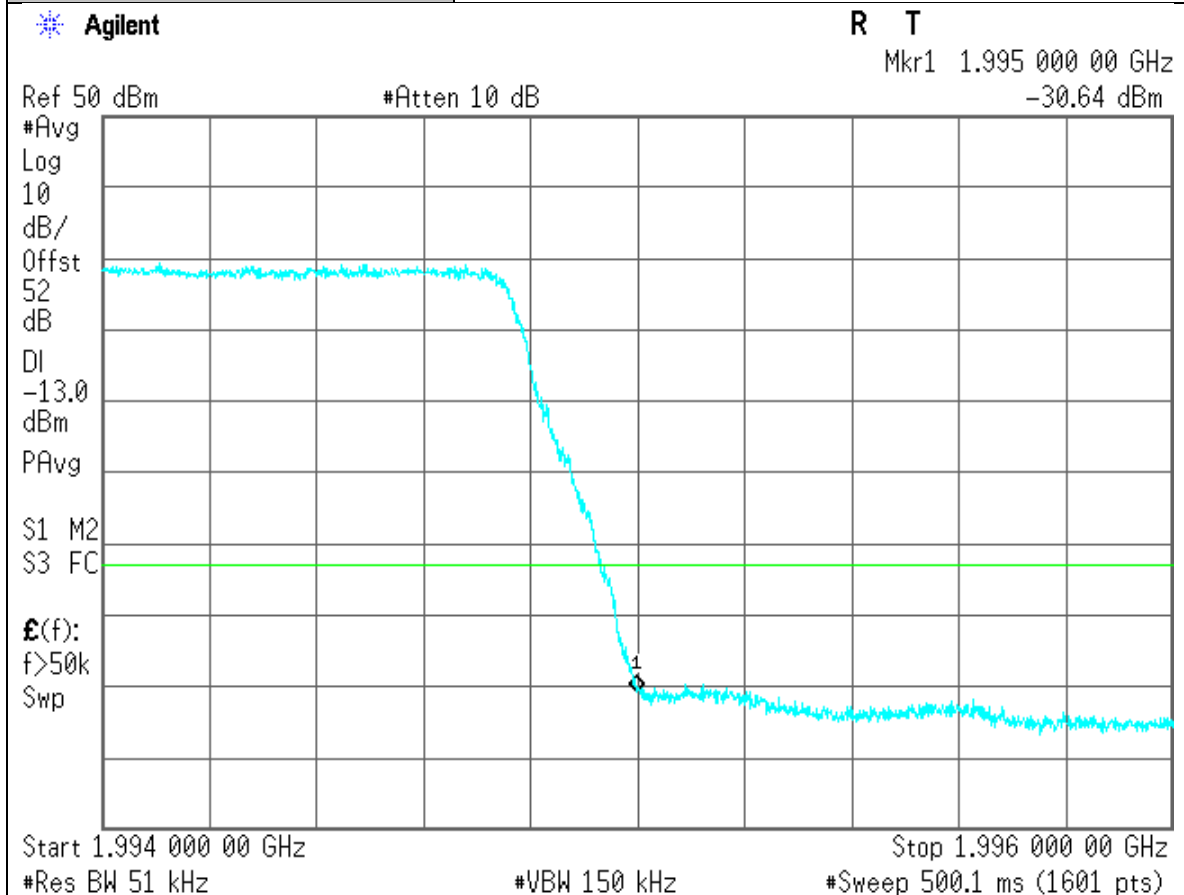

Project Number:	0048-130617-01
EUT:	AA190045
PARTS NO.:	RF151032
Tested By:	Wei Li
Temperature:	70°F
Humidity:	30%

Section:	Spurious Emissions at RF Output Port:
Plot Name:	Downlink, Hi-Chn, Upper Bandedge
Configuration:	Input: Digital; Output: TX1 RF Output TM 32 5MHz Carrier

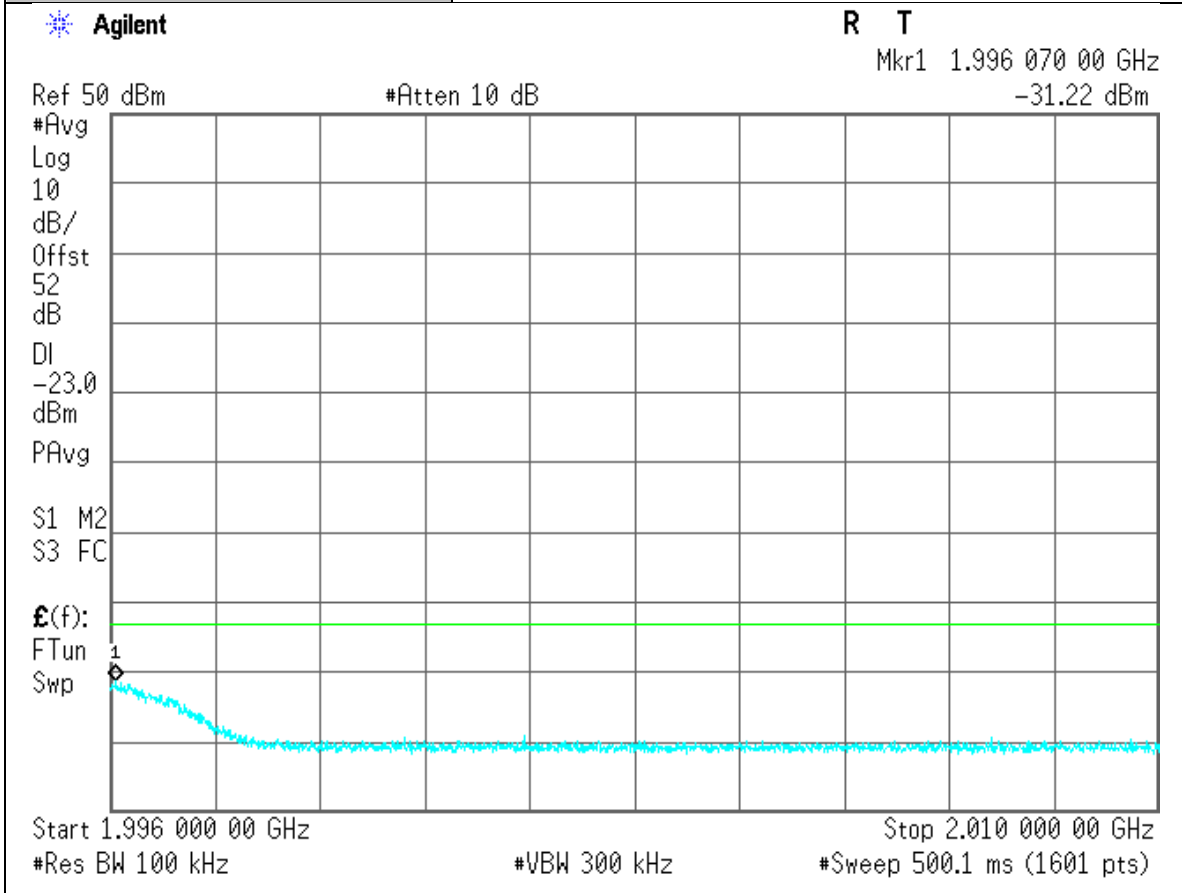

Project Number:	0048-130617-01
EUT:	AA190045
PARTS NO.:	RF151032
Tested By:	Wei Li
Temperature:	70°F
Humidity:	30%

Section:	Spurious Emissions at RF Output Port:
Plot Name:	Downlink, Low-Chn, Lower Bandedge
Configuration:	Input: Digital; Output: TX1 RF Output TM 32 5MHz Carriers

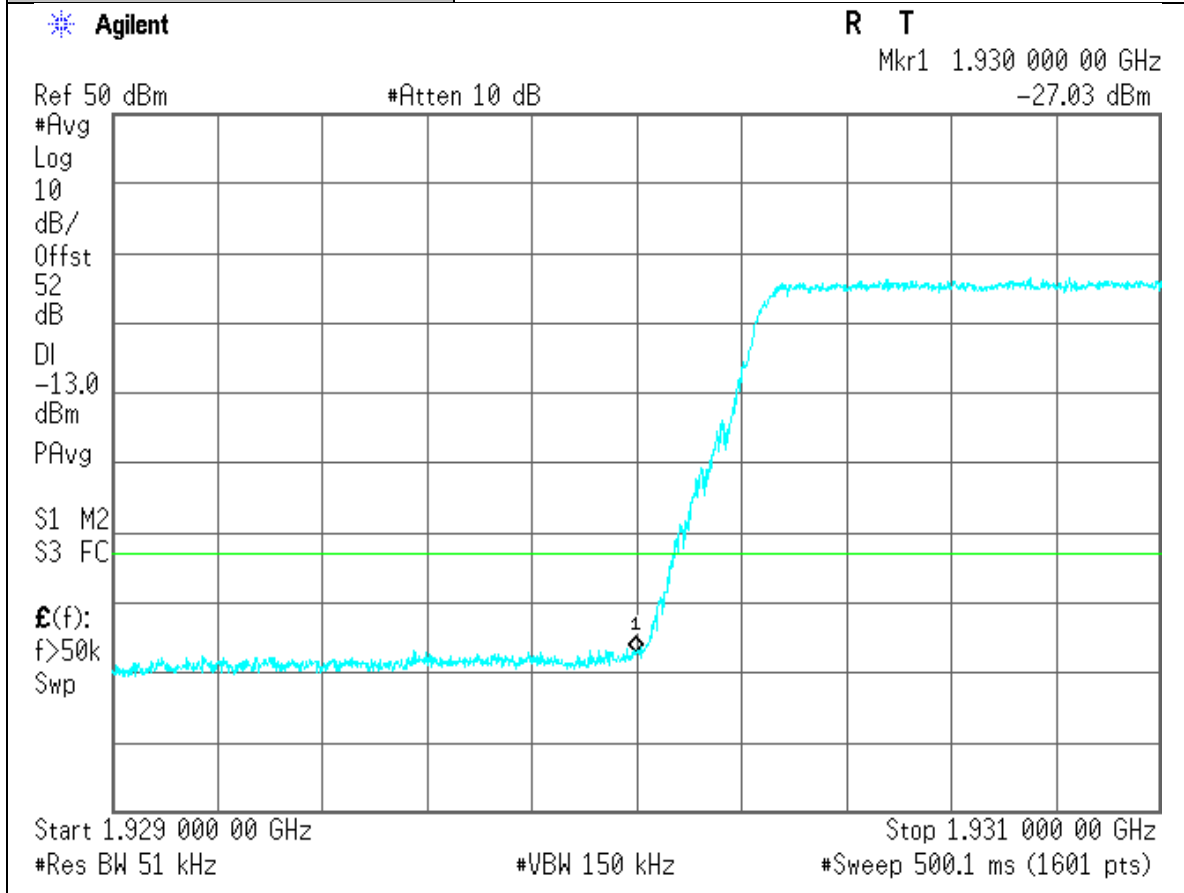

Project Number:	0048-130617-01
EUT:	AA190045
PARTS NO.:	RF151032
Tested By:	Wei Li
Temperature:	70°F
Humidity:	30%

Section:	Spurious Emissions at RF Output Port:
Plot Name:	Downlink, Low-Chn, Lower Bandedge
Configuration:	Input: Digital; Output: TX1 RF Output TM 32 5MHz Carriers

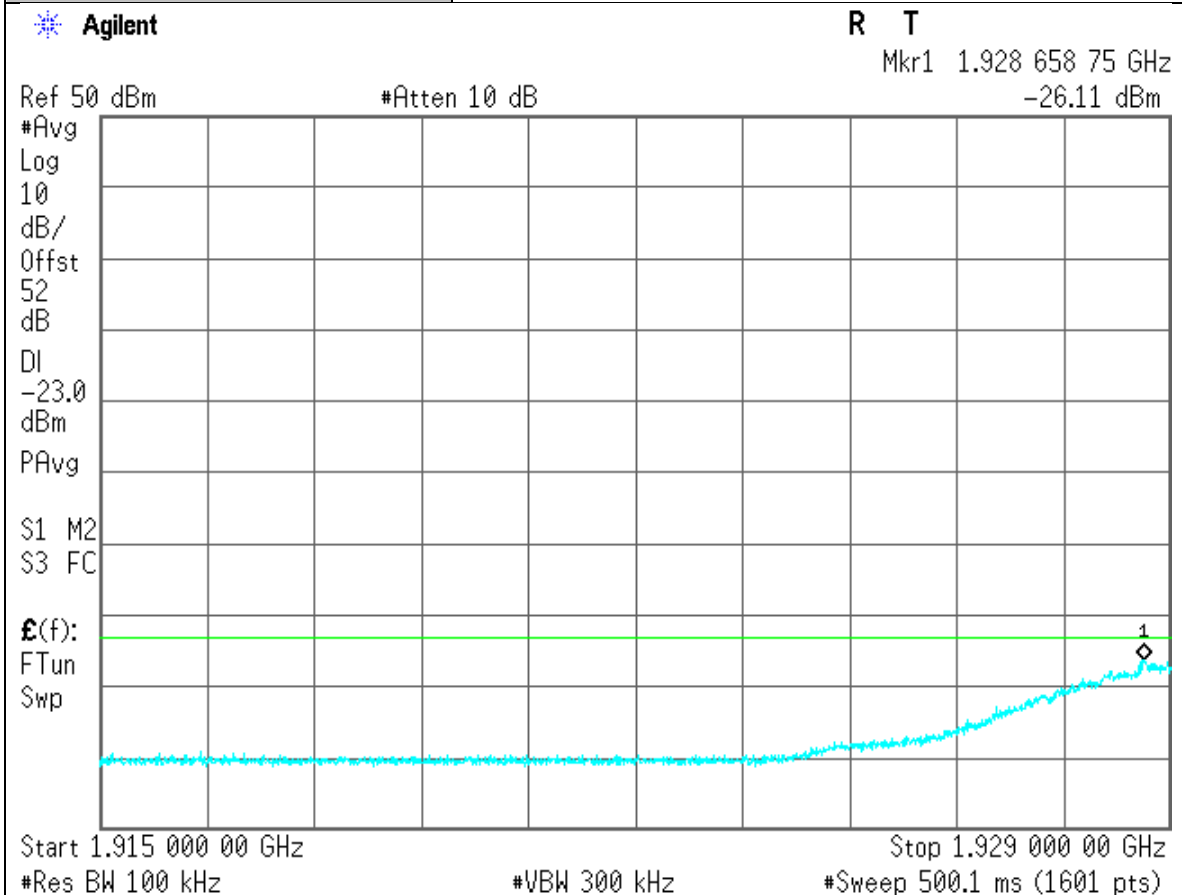

Project Number:	0048-130617-01
EUT:	AA190045
PARTS NO.:	RF151032
Tested By:	Wei Li
Temperature:	70°F
Humidity:	30%

Section:	Spurious Emissions at RF Output Port:
Plot Name:	Downlink, Hi-Chn, Upper Bandedge
Configuration:	Input: Digital; Output: TX1 RF Output TM 32 5MHz Carriers

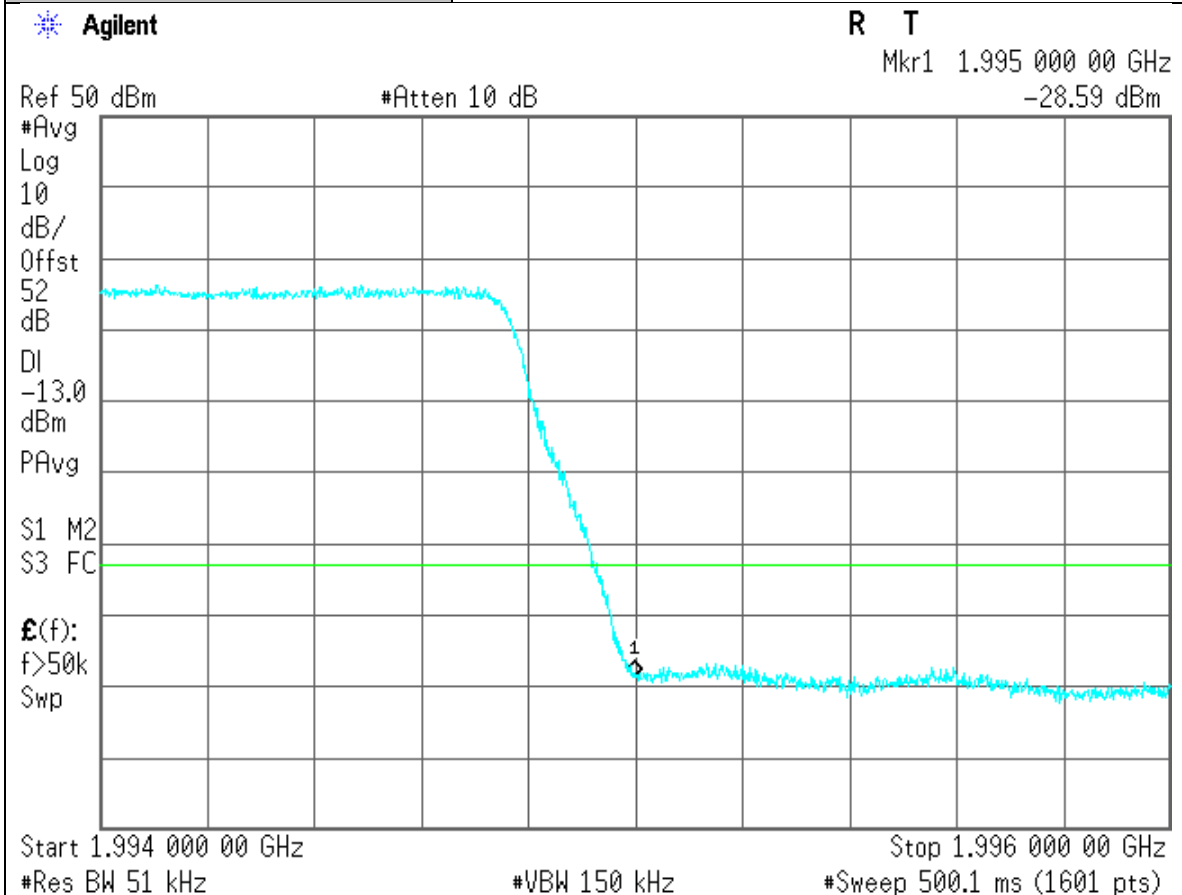

Project Number:	0048-130617-01
EUT:	AA190045
PARTS NO.:	RF151032
Tested By:	Wei Li
Temperature:	70°F
Humidity:	30%

Section:	Spurious Emissions at RF Output Port:
Plot Name:	Downlink, Hi-Chn, Upper Bandedge
Configuration:	Input: Digital; Output: TX1 RF Output TM 32 5MHz Carriers

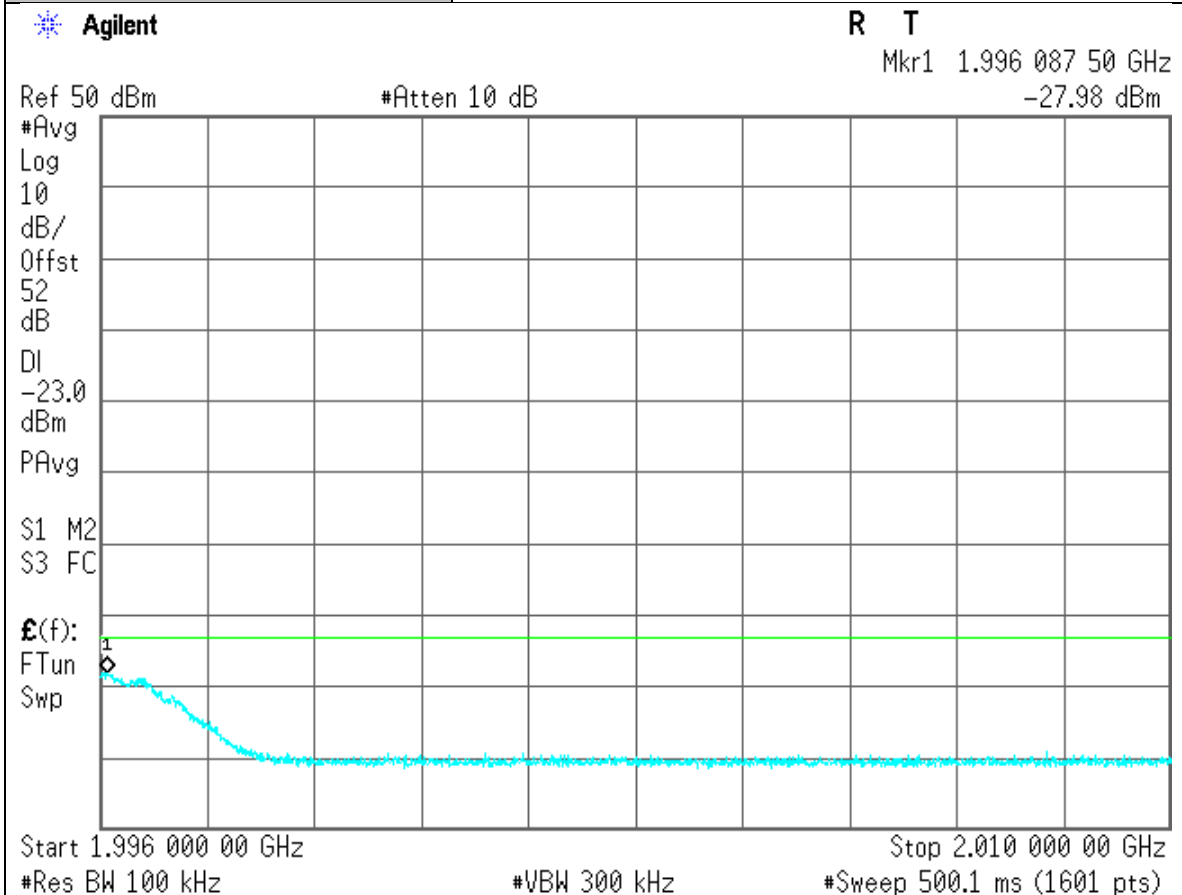

Project Number:	0048-130617-01
EUT:	AA190045
PARTS NO.:	RF151032
Tested By:	Wei Li
Temperature:	70°F
Humidity:	30%

Section:	Spurious Emissions at RF Output Port:
Plot Name:	Downlink, Worst Case 9kHz to 20GHz
Configuration:	Input: Digital; Output: TX1 RF Output TM 11 5MHz Carrier, Low Channel

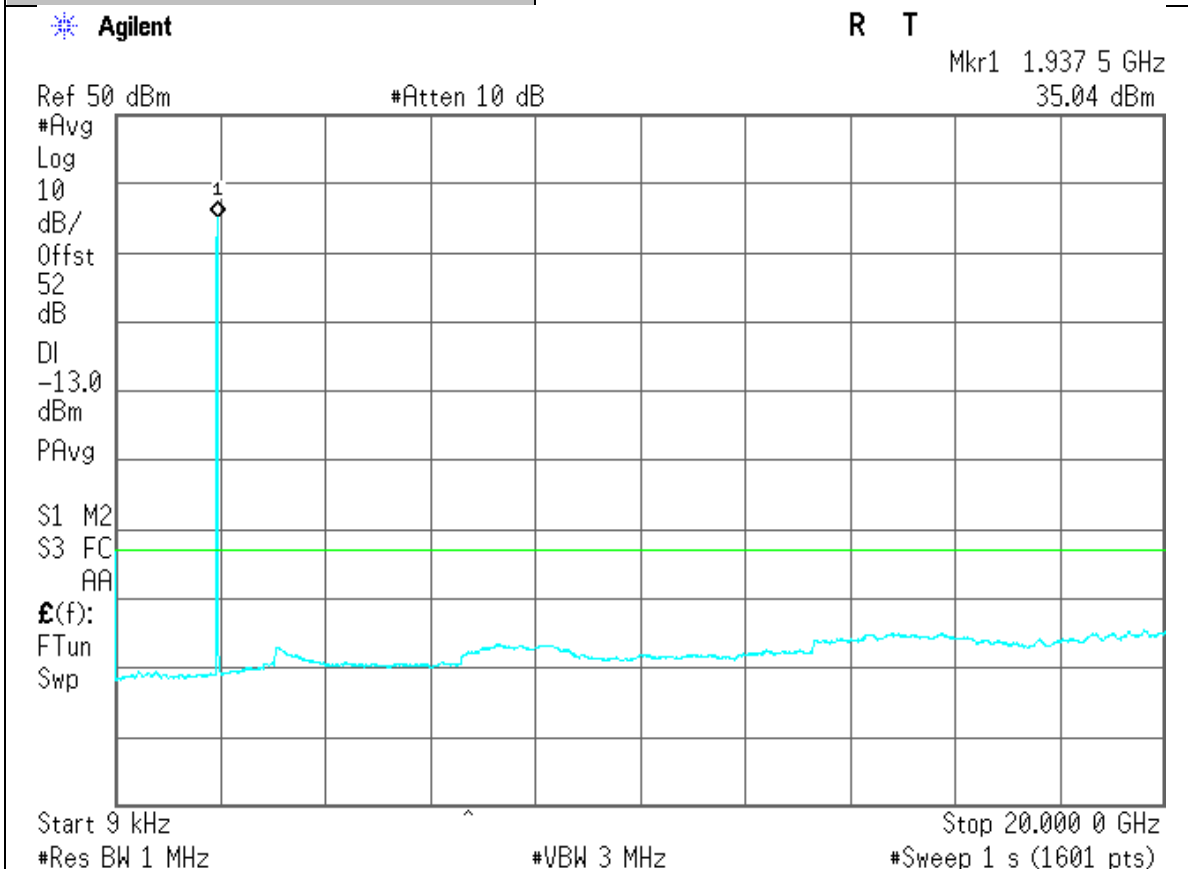

Project Number:	0048-130617-01
EUT:	AA190045
PARTS NO.:	RF151032
Tested By:	Wei Li
Temperature:	70°F
Humidity:	30%

Section:	Spurious Emissions at RF Output Port:
Plot Name:	Downlink, Worst Case 9kHz to 20GHz
Configuration:	Input: Digital; Output: TX1 RF Output TM 11 5MHz Carrier, Mid Channel

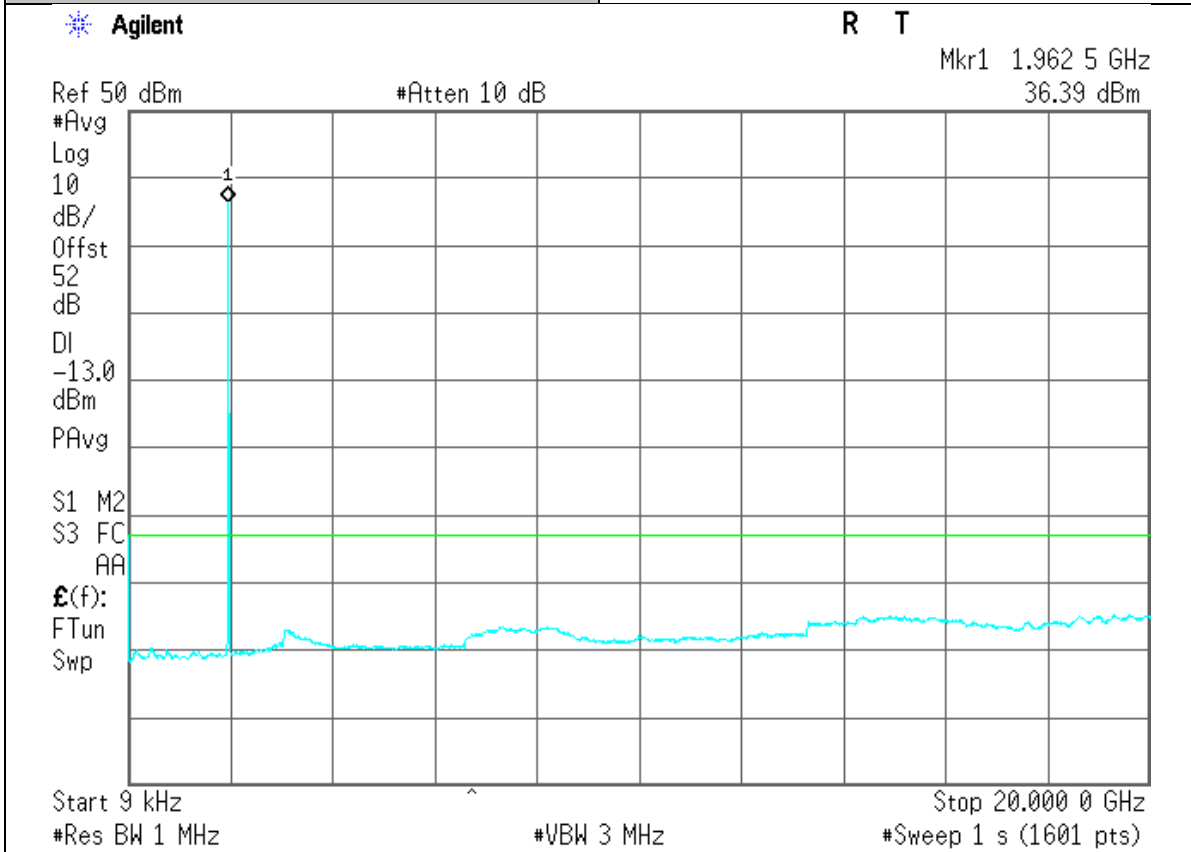

Project Number:	0048-130617-01
EUT:	AA190045
PARTS NO.:	RF151032
Tested By:	Wei Li
Temperature:	70°F
Humidity:	30%

Section:	Spurious Emissions at RF Output Port:
Plot Name:	Downlink, Worst Case 9kHz to 20GHz
Configuration:	Input: Digital; Output: TX1 RF Output TM 11 5MHz Channel, Hi Channel

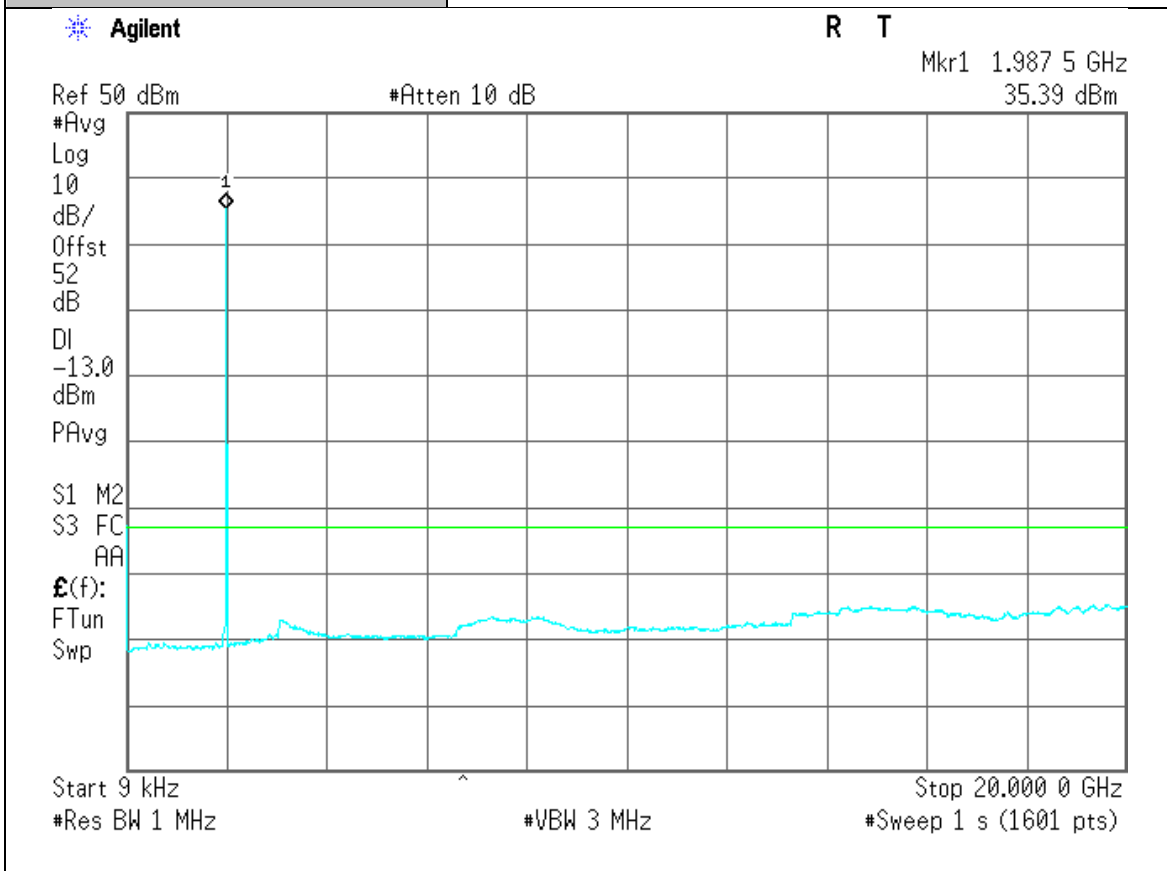

Project Number:	0048-130617-01
EUT:	AA190045
PARTS NO.:	RF151032
Tested By:	Wei Li
Temperature:	70°F
Humidity:	30%

Section:	Spurious Emissions at RF Output Port:
Plot Name:	Downlink, Worst Case 9kHz to 20GHz
Configuration:	Input: Digital; Output: TX1 RF Output TM 31 5MHz Carrier, Low Channel

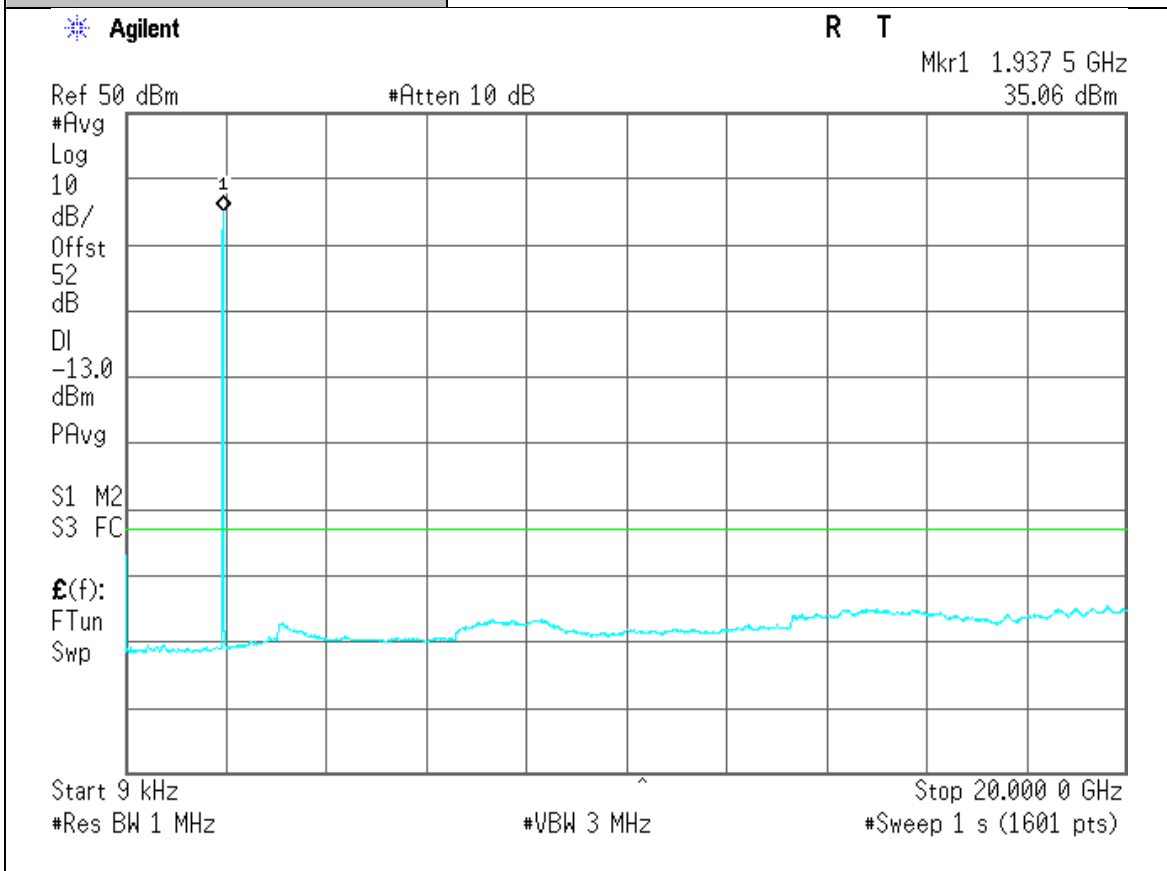

Project Number:	0048-130617-01
EUT:	AA190045
PARTS NO.:	RF151032
Tested By:	Wei Li
Temperature:	70°F
Humidity:	30%

Section:	Spurious Emissions at RF Output Port:
Plot Name:	Downlink, Worst Case 9kHz to 20GHz
Configuration:	Input: Digital; Output: TX1 RF Output TM 31 5MHz Carrier, Mid Channel

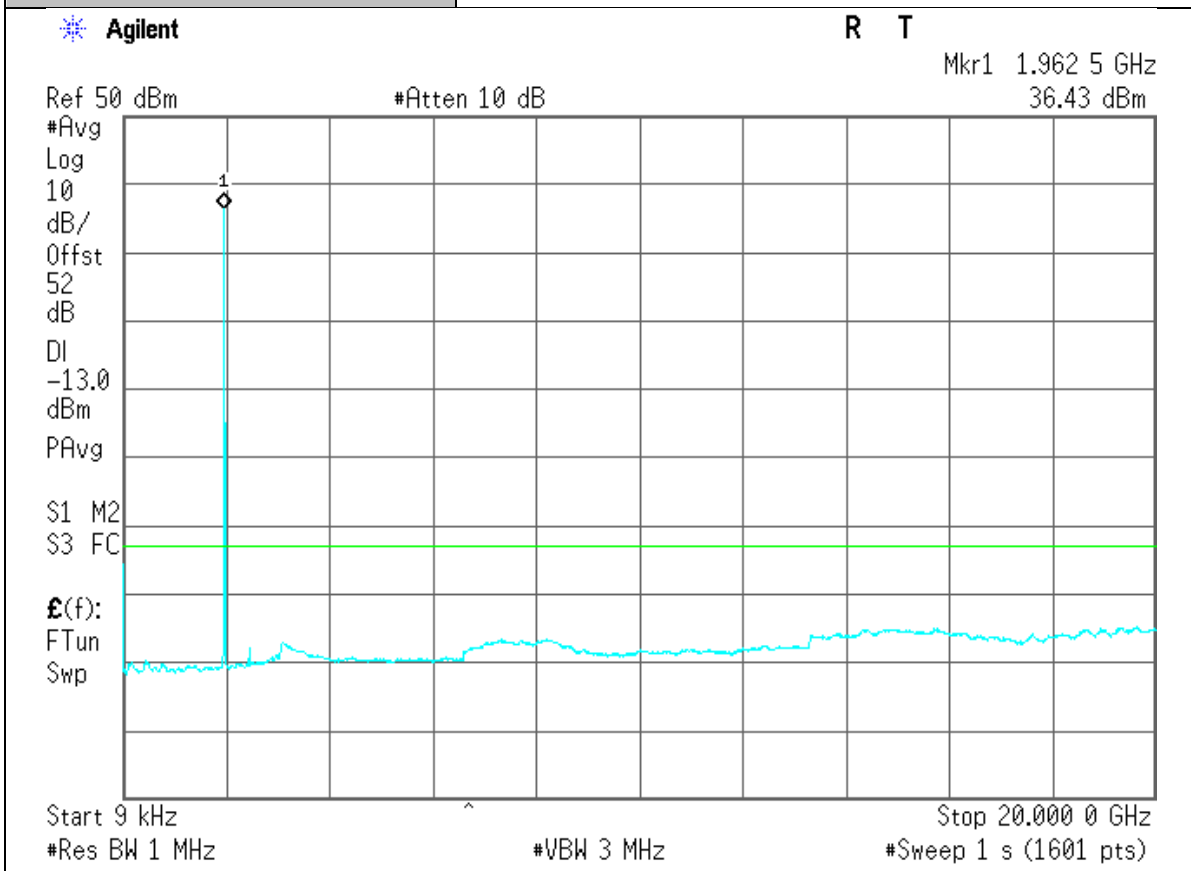

Project Number:	0048-130617-01
EUT:	AA190045
PARTS NO.:	RF151032
Tested By:	Wei Li
Temperature:	70°F
Humidity:	30%

Section:	Spurious Emissions at RF Output Port:
Plot Name:	Downlink, Worst Case 9kHz to 20GHz
Configuration:	Input: Digital; Output: TX1 RF Output TM 31 5MHz Carrier, Hi Channel

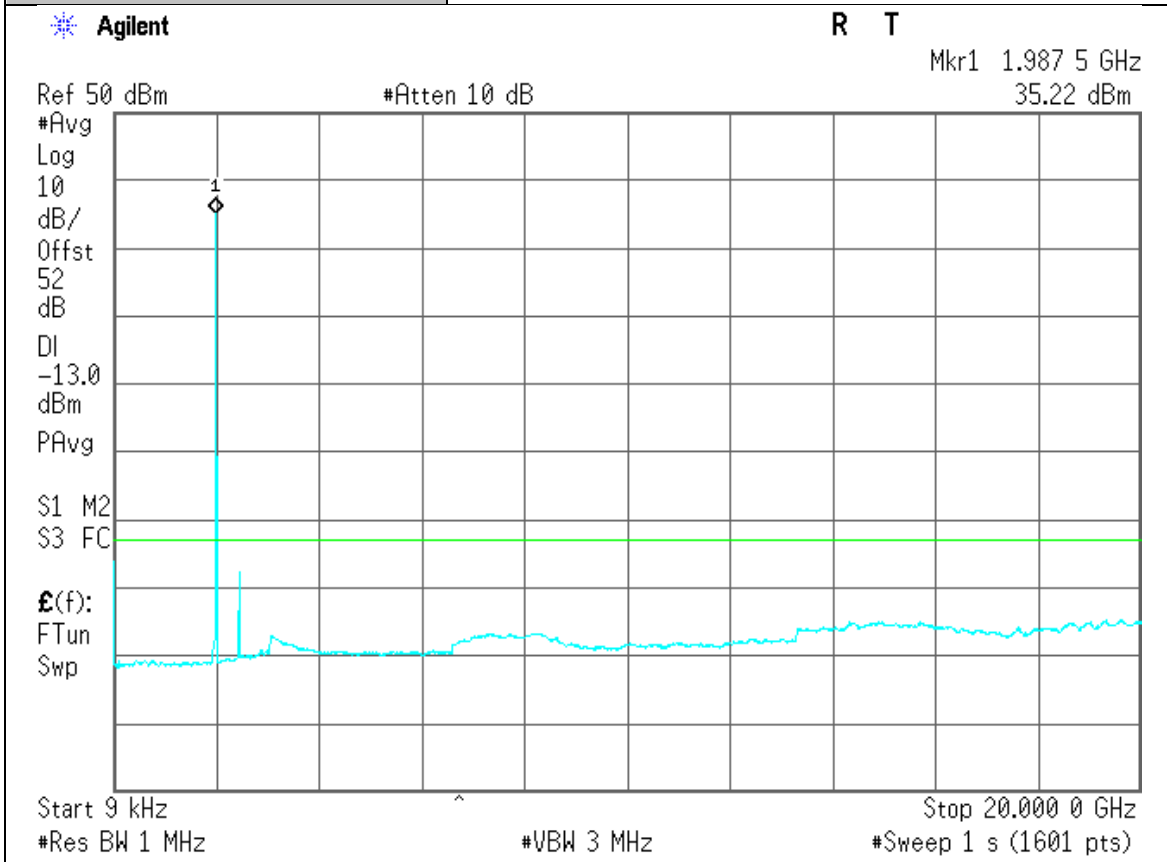

Project Number:	0048-130617-01
EUT:	AA190045
PARTS NO.:	RF151032
Tested By:	Wei Li
Temperature:	70°F
Humidity:	30%

Section:	Spurious Emissions at RF Output Port:
Plot Name:	Downlink, Worst Case 9kHz to 20GHz
Configuration:	Input: Digital; Output: TX1 RF Output TM 32 5MHz Carrier, Low Channel

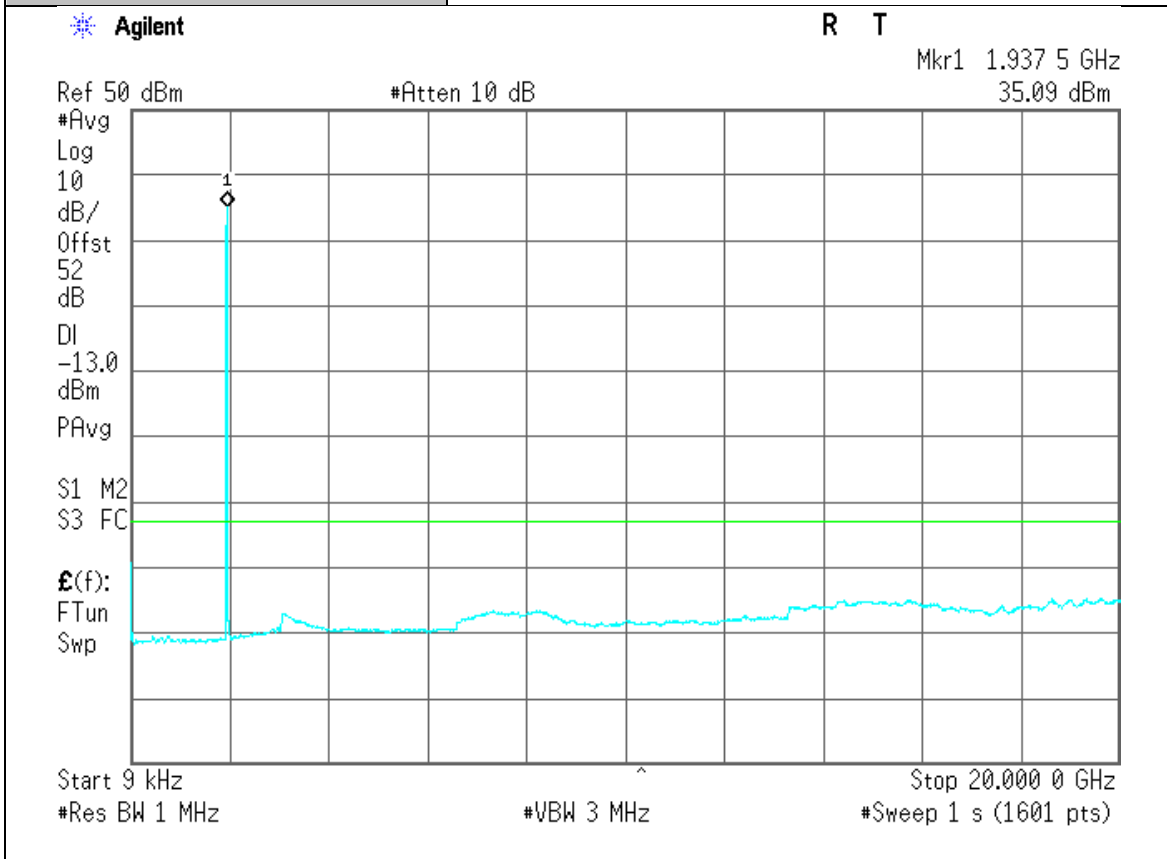

Project Number:	0048-130617-01
EUT:	AA190045
PARTS NO.:	RF151032
Tested By:	Wei Li
Temperature:	70°F
Humidity:	30%

Section:	Spurious Emissions at RF Output Port:
Plot Name:	Downlink, Worst Case 9kHz to 20GHz
Configuration:	Input: Digital; Output: TX1 RF Output TM 32 5MHz Carrier, Mid Channel

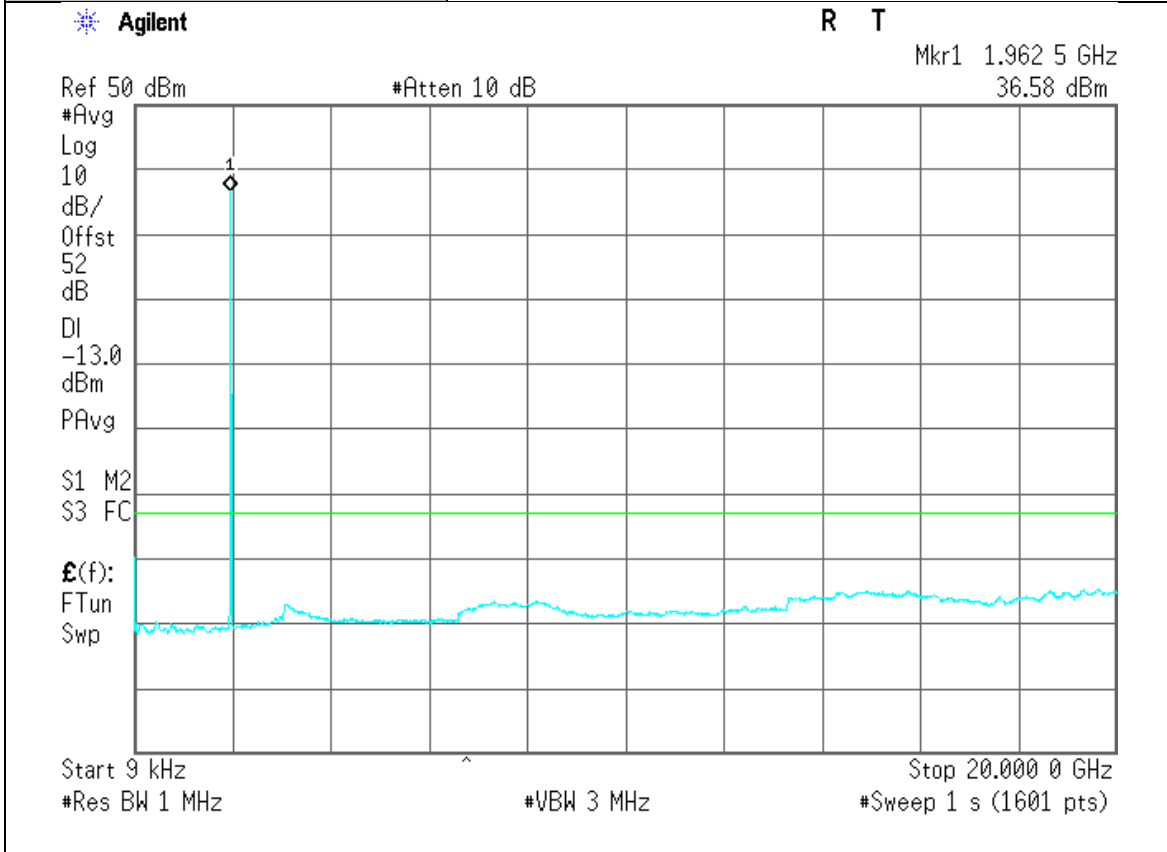

Project Number:	0048-130617-01
EUT:	AA190045
PARTS NO.:	RF151032
Tested By:	Wei Li
Temperature:	70°F
Humidity:	30%

Section:	Spurious Emissions at RF Output Port:
Plot Name:	Downlink, Worst Case 9kHz to 20GHz
Configuration:	Input: Digital; Output: TX1 RF Output TM 32 5MHz Carrier, Hi Channel

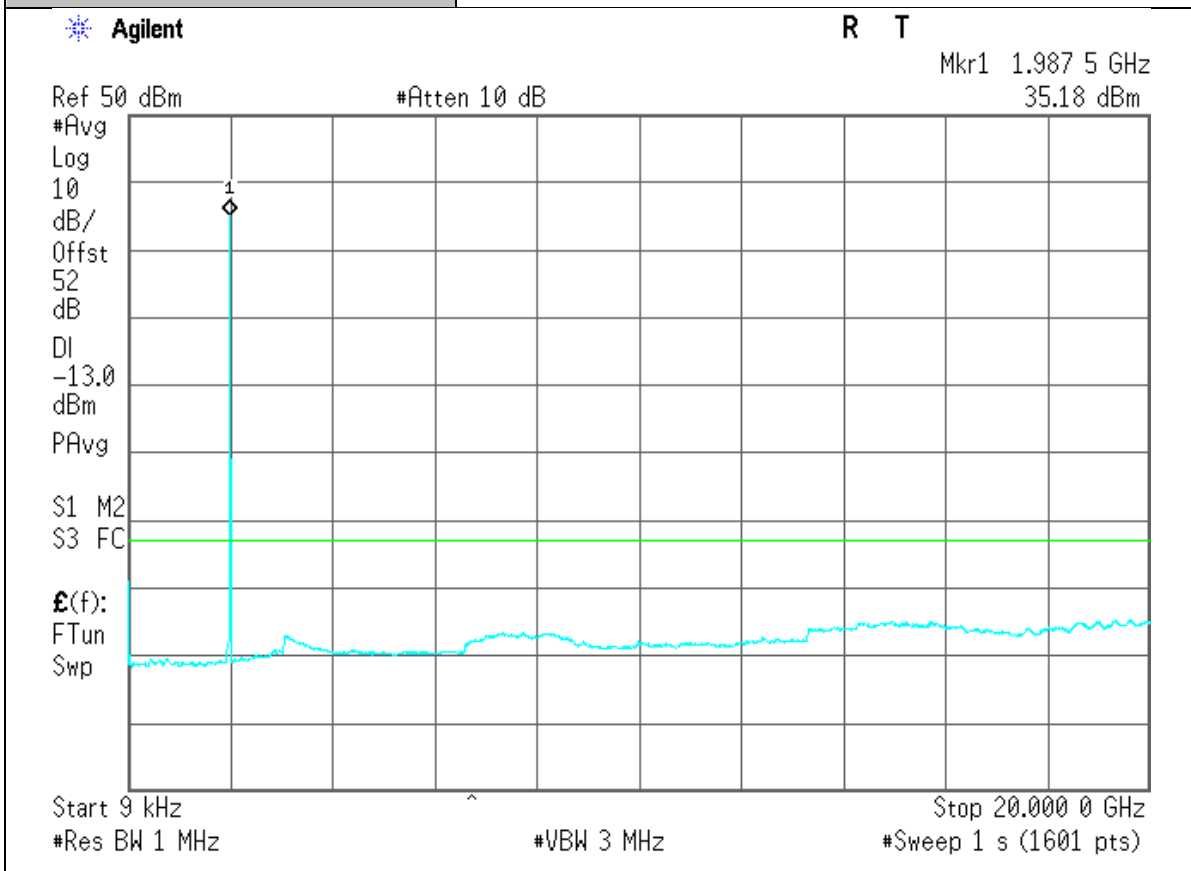

Project Number:	0048-130617-01
EUT:	AA190045
PARTS NO.:	RF151032
Tested By:	Wei Li
Temperature:	70°F
Humidity:	30%

Section:	Spurious Emissions at RF Output Port:
Plot Name:	Downlink, Worst Case 9kHz to 20GHz
Configuration:	Input: Digital; Output: TX1 RF Output TM 11 5MHz Carriers(2), Mid Channel

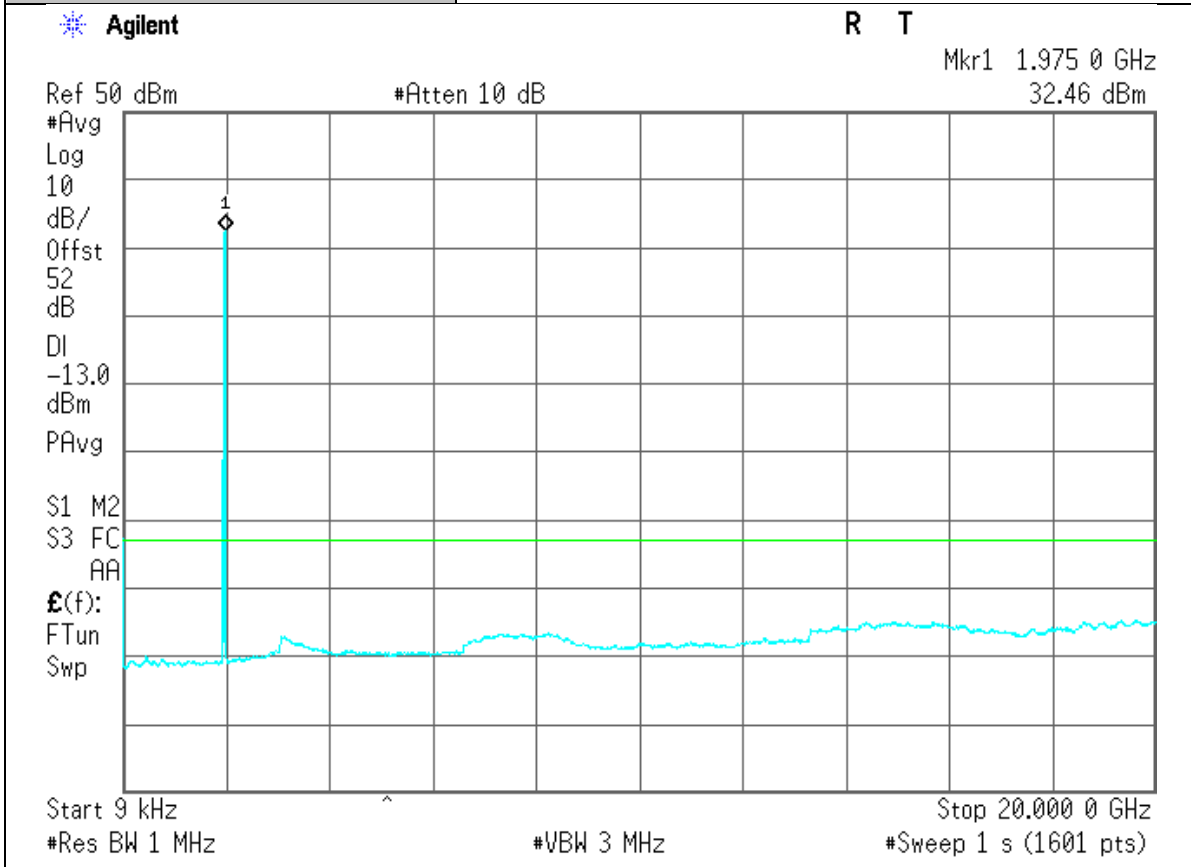

Project Number:	0048-130617-01
EUT:	AA190045
PARTS NO.:	RF151032
Tested By:	Wei Li
Temperature:	70°F
Humidity:	30%

Section:	Spurious Emissions at RF Output Port:
Plot Name:	Downlink, Worst Case 9kHz to 20GHz
Configuration:	Input: Digital; Output: TX1 RF Output TM 31 5MHz Carriers(2), Mid Channel

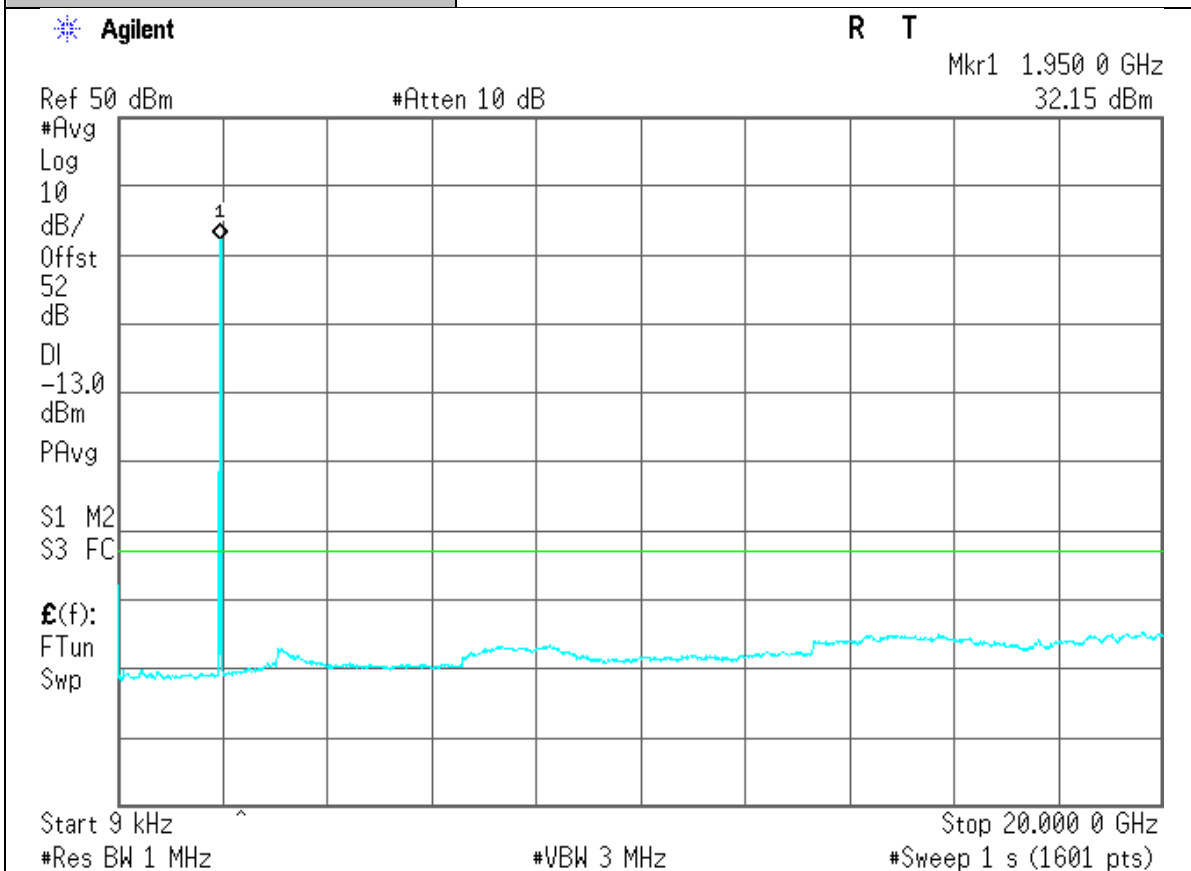

Project Number:	0048-130617-01
EUT:	AA190045
PARTS NO.:	RF151032
Tested By:	Wei Li
Temperature:	70°F
Humidity:	30%

Section:	Spurious Emissions at RF Output Port:
Plot Name:	Downlink, Worst Case 9kHz to 20GHz
Configuration:	Input: Digital; Output: TX1 RF Output TM 32 5MHz Carrier(2), Mid Channel

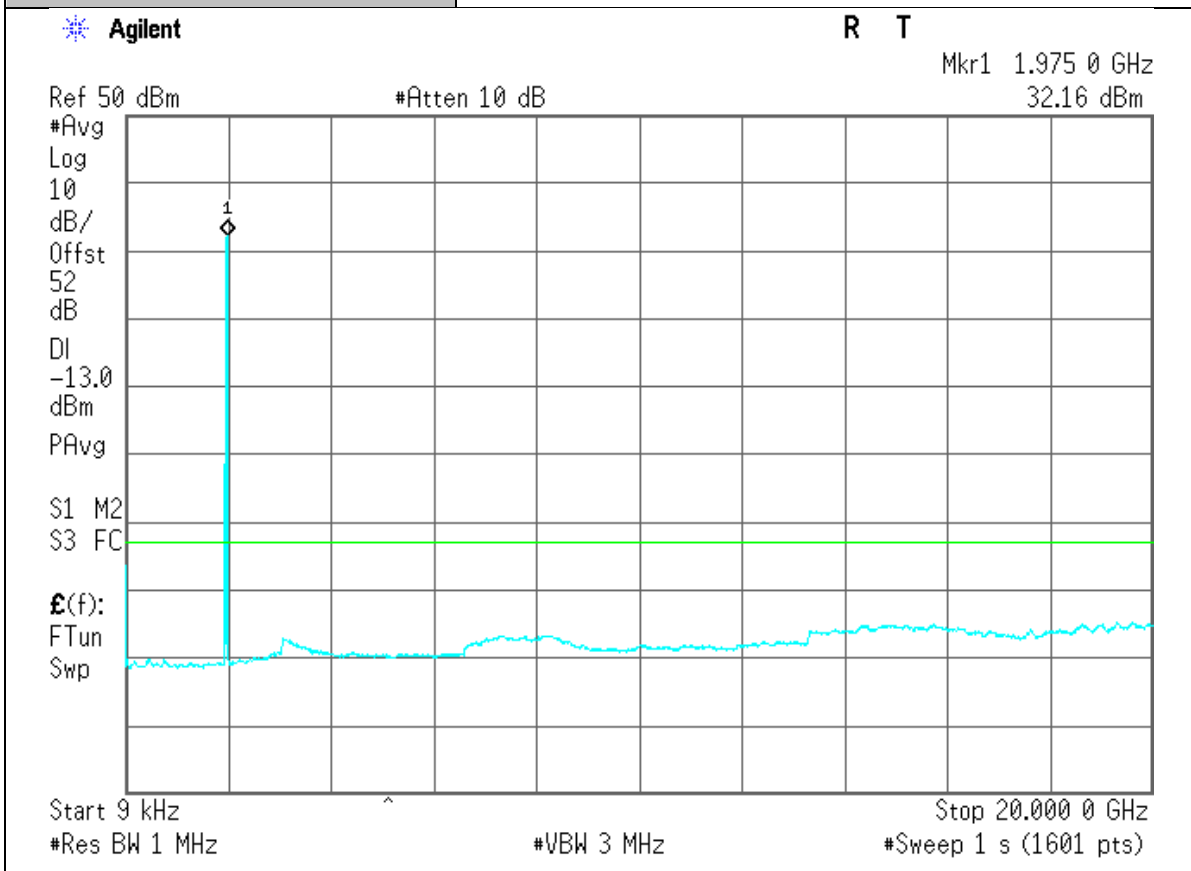

Section 6. Field Strength of Spurious

Name of Test:	<i>Field Strength of Spurious</i>	Test Standard:	<i>22.917</i> <i>24.238</i>
Tested By:	WEI LI	Test Date:	06/17/2013-06/25/2013

Minimum

Standard: Para. No. 24.238(a). The magnitude of each spurious and harmonic emission that can be detected when the equipment is operated under conditions specified in the instruction manual and/or alignment procedure, shall not less than $43+10 \log$ (mean output power in watts) dBc below the mean power output outside a licensee's frequency block (-13dBm).

Method of Measurement: TIA/EIA-603, Section 2.2.12
The antenna substitution method was used to determine the equivalent radiated power at spurious frequencies. The spurious emissions were measured at a distance of 3 meters. The EUT was then replaced with a reference substitution antenna with a known gain referenced to a dipole. This antenna was fed with a signal at the spurious frequency. The level of the signal was adjusted to repeat the previously measured level. The resulting ERP is the signal level fed to the reference antenna corrected for gain referenced to a dipole.

Per FCC KDB 971168 v2r01, Measurement Guidance for Certification of Licensed Digital Transmitters, the approach using Mathematical Conversions in Sec. 5.8.3 can be used in this case.

*Base on pre-testing results for different operation modes shown on page 7, the data for the worst case, 5MHz BW/QPSK/1 Carrier, configuration, was recorded as final result.

Test Result:

Complies

Test Data:

See Attached Table(s)

Configuration	LTE w/ Rated Output Power. Port 1 and 2 Terminated with 50 Ohm Load.
Band	Broadband PCS Downlink
Channel	Low

Freq. (MHz)	H,V	SA Reading (dBuV)	Height (m)	Angle (degree)	EIRP =E-95.3 @ 3m (dBm)**		Absolute Limit (dBm)	Margin (dB)
3864	H	41.0	1.0	000	-54.3		-13	-41.3
5796.5	H	42.8	1.1	045	-52.5		-13	-39.5
7729	H	43.9	1.2	000	-51.4		-13	-38.4
3864	V	40.2	1.1	180	-55.1		-13	-42.1
5796.5	V	43.3	1.0	235	-52.0		-13	-39
7729	V	42.3	1.1	235	-53.0		-13	-40

NOTE:

* Measured noise floor

SA: Spectrum Analyzer

EUT's Signal.: 5MHz BW/QPSK /1 Carrier as worst case

H=horizontal and V=vertical

** Per FCC KDB 971168 D01 Power Measurement License Digital Systems v02r01. Sec. 5.8.3 with D=3m.

Configuration	LTE w/ Rated Output Power. Port 1 and 2 Terminated with 50 Ohm Load.
Band	Broadband PCS Downlink
Channel	Middle

Freq. (MHz)	H,V	SA Reading (dBuV)	Height (m)	Angle (degree)	EIRP =E-95.3 @ 3m (dBm)**		Absolute Limit (dBm)	Margin (dB)
3925	H	40.4	1.1	045	-54.9		-13	-41.9
5887.5	H	40.9	1.1	045	-54.4		-13	-41.4
7850	H	42.4	1.2	000	-52.9		-13	-39.9
3925	V	43.5	1.1	180	-51.8		-13	-38.8
5887.5	V	41.4	1.0	180	-53.9		-13	-40.9
7850	V	42.6	1.1	180	-52.7		-13	-39.7

NOTE:

* Measured noise floor

SA: Spectrum Analyzer

EUT's Signal.: 5MHz BW/QPSK /1 Carrier as worst case

H=horizontal and V=vertical

** Per FCC KDB 971168 D01 Power Measurement License Digital Systems v02r01. Sec. 5.8.3 with D=3m.

Configuration	LTE w/ Rated Output Power. Port 1 and 2 Terminated with 50 Ohm Load.
Band	Broadband PCS Downlink
Channel	High

Freq. (MHz)	H,V	SA Reading (dBuV)	Height (m)	Angle (degree)	EIRP =E-95.3 @ 3m (dBm)**		Absolute Limit (dBm)	Margin (dB)
3985	H	40.6	1.1	000	-54.7		-13	-41.7
5997.5	H	44.1	1.1	045	-51.2		-13	-38.2
7970	H	45.3	1.2	000	-50		-13	-37
3985	V	39.7	1.1	180	-55.6		-13	-42.6
5997.5	V	44.1	1.0	235	-51.2		-13	-38.2
7970	V	43.7	1.1	235	-51.6		-13	-38.6

NOTE:

* Measured noise floor

SA: Spectrum Analyzer

EUT's Signal.: 5MHz BW/QPSK /1 Carrier as worst case

H=horizontal and V=vertical

** Per FCC KDB 971168 D01 Power

Measurement License Digital Systems v02r01. Sec. 5.8.3 with D=3m.

Section 7. Frequency Stability

Name of Test:	<i>Frequency Stability</i>	Test Standard:	<i>2.1055 22.355&24.235</i>
Tested By:	WEI LI	Test Date:	06/17/2013-06/25/2013

Minimum Standard: Para No. 24.235. The frequency stability shall be sufficient to ensure that the fundamental emission stays within the authorized frequency block.

Method of Measurement: Frequency Stability With Voltage Variation:
The E.U.T. is placed in an environmental chamber and allowed to stabilize at +25 degrees Celsius for at least 15 minutes. Set SA resolution bandwidth low enough (30Hz) to obtain the desired frequency resolution. (Using frequency counter method: The frequency counter and signal generator are phase locked with the same 10 MHz reference frequency by connecting the 10 MHz ref. out of the counter to the 10MHz ref, in of the signal generator). With the voltage input to the E.U.T. set to 85% S.T.V., the frequency is measured in 30 second intervals for a period of 5 minutes. This procedure is repeated at 100% S.T.V. and 115% S.T.V.

Frequency Stability With Temperature Variation:
The input voltage to the E.U.T. is set to S.T.V. and the temperature of the environmental chamber is varied in 10 degree steps from -40 degrees C to +60 degrees C. The E.U.T. is allowed to stabilize at each temperature and the frequency is measured in 30 second intervals for a period of 5 minutes.

Test Result: **Complies**

Test Data: See Attached Table

Frequency Stability Data

Transmit Frequency Versus: Temperature, DC Supply Voltage, and Carrier Bandwidths

DC Supply Voltage (V)	Temp (C)	Freq Error @ TX1 (Hz)			Freq Error @ TX2 (Hz)		
		5MHz	10MHz	20MHz	5MHz	10MHz	20MHz
-48	-40	3.6	1.2	5.1	2.5	4.4	7
-48	-30	2.3	2.7	2.9	0.9	0.7	3.3
-48	-20	1	1	4.3	2.9	0.3	0.8
-48	-10	2.8	2.2	3.6	0.8	3.8	1.1
-48	0	2.5	2.2	2.3	3.1	4.6	2
-48	10	0.1	1.6	1.5	0.2	0.6	1.2
-48	20	0.9	1.4	1.1	1.2	2.4	0.6
-48	30	2.9	0.5	0.2	0	2.5	2.7
-48	40	3.5	0.2	0.6	0.4	3.2	0.7
-48	50	0.4	0.9	1.1	1.8	2.6	0.3
-48	60	1.7	0.2	0.5	3.3	0.7	0.1
-39.5	25	0.6	1.6	0.5	4.3	4.4	3.1
-57	25	2	0.1	1.3	0.9	0.7	0.6
Maximum freq. error(Hz)		7					

FCC limit: 0.05ppm

Conclusion: Max. frequency error = 7Hz, i.e. 0.00357ppm < the limit 0.05

Section 8. Test Equipment List

Manufacture	Model	Serial No.	Description	Cal Due dd/mm/yy
HP	HP8546A	3448A00290	EMI Receiver	15/09/13
HP	E4432B	US38220355	250K-3GHz Signal Generator	15/07/13
EMCO	3104C	9307-4396	20-300MHz Biconical Antenna	15/09/13
EMCO	3146	9008-2860	200-1000MHz Log-Periodic Antenna	09/02/14
Fischer Custom	LIPARTS NO.-2	900-4-0008	Line Impedance Stabilization Networks	15/09/13
Fischer Custom	LIPARTS NO.-2	900-4-0009	Line Impedance Stabilization Networks	23/08/13
EMCO	6502	2665	10KHz-30MHz Active Loop Antenna	27/02/14
EMCO	3115	4945	Double Ridge Guide Horn Antenna	13/09/13
R&S	ESPI	100018	EMI Receiver	16/07/13
HP	8569B	2607A02802	1GHz-22GHz Spectrum Analyzer	10/02/14
Delta Design	5900C	0-67-26	Temperature Chamber	24/03/14
HP	E8254A	US42110367	Signal Generator	23/03/14
Electro-Metrics	RGA-15	8-95	Double Ridge Guide Horn Antenna	10/02/14
EMCO	3116	4943	Double Ridge Guide Horn Antenna	11/01/14
Scientific-Atlanta	12A-18	441	Wave Guide Horn Antenna	04/08/14
HP	4419A	US37292112	RF Power Meter w/ Sensor Probe	20/07/13
Chamber	GD-32-33	LN2	Temperature Chamber	28/07/13
HP	6032A	3323A-09526	System Power Supply	01/07/13
Agilent	E4438C	US41460731	ESG Vector Signal Generator	01/07/13
Agilent	E4438C	US41460771	ESG Vector Signal Generator	01/07/13
Agilent	E4438C	US41460400	ESG Vector Signal Generator	01/07/13
Agilent	E4440A	US40420700	3Hz-26.5GHz Spectrum Analyzer	12/05/14
Lorch Microwave	5NF- 800/1000-S	AC3	Notch Filter	
Lorch Microwave	5NF- 1800/2200-S	AE10	Notch Filter	
RES-NET	RFA500NFF 30	0108	30dB in-line Power Attenuator	
Narda	3043B-10	42255	Coaxial Directional Coupler	