

**Advanced
Compliance Laboratory**

6 Randolph Way
Hillsborough, NJ 08844
Tel: (908) 927 9288
Fax: (908) 927 0728

**Electromagnetic
Emission
Compliance
Test Report**



**Equipment Under Test
(EUT)
Applicant** 1960 CDMA Multiple Carrier Power Amplifier
RF100978
Andrew Corporation

In Accordance With FCC Part 24, Subpart E

Test by Advanced Compliance Laboratory, Inc.
6 Randolph Way
Hillsborough, New Jersey 08844

Authorized by Wei Li
Lab Manager

Signature

Date March 21, 2008

**AC Lab Report
Number** 0048-080310-01



Lab Code:200101-0

**The test result in this report is supported and
covered by the NVLAP accreditation.**

Index

Section 1. Summary of Test Results	3
Section 2. General Equipment Specification	5
Section 3. RF Output Power	7
Section 4. Occupied Bandwidth	11
Section 5. Spurious Emissions at Antenna Terminals	19
Section 6. Field Strength of Spurious	35
Section 7. Frequency Stability	41
Section 8. Test Equipment List	43
Section 9. FCC ID Labeling	44
Section 10. Maximum Permissible Exposure	45
Section 11. Setup Photos	46
Section 12. EUT Photos	50

Section 1. Summary of Test Results

Manufacturer: Andrew Corporation

Model No.: 1960 CDMA Multiple Carrier Power Amplifier
RF100978

S/N: PT004

General: **All measurements are traceable to national standards**

These tests were conducted on a sample of the equipment for the purpose of demonstrating compliance with Part 24, Subpart E.

New Submission

Production Unit

Class II Permissive Change

Pre-Production Unit

THIS TEST REPORT RELATES ONLY TO THE ITEM(S) TESTED.

THE FOLLOWING DEVIATIONS FROM, ADDITIONS TO, OR EXCLUSIONS FROM THE TEST SPECIFICATIONS HAVE BEEN MADE.

“See Summary of Test Data”



NVLAP LAB CODE: 200101-0

Advance Compliance Laboratory, Inc. authorizes the above named company to reproduce this report provided it is reproduced in its entirety and for use by the company's employees only.

Any use which a third party makes of this report, or any reliance on or decisions to be made based on it, are the responsibility of such third parties. Advance Compliance Laboratory, Inc. accepts no responsibility for damages, if any, suffered by any third party as a result of decisions made or actions based on this report. This report applies only to the items tested.

Summary of Test Data

RF Power Output	22.913(a)	500W ERP	N/A*
	24.232(a)	100W EIRP	Complies**
Occupied Bandwidth (Voice & SAT)	2.1049(i)	Mask	N/A*
Occupies Bandwidth (Wideband Data)	2.1049(i)	Mask	N/A*
Occupied Bandwidth (Digital)	2.1049(i)	Mask	Complies
Spurious Emissions at Antenna Terminals	22.917	-13 dBm	N/A*
	24.238	-13 dBm	Complies
Field Strength of Spurious Emissions	22.917	-13 dBm	N/A*
	24.238	-13 dBm E.I.R.P.	Complies
Frequency Stability	22.355	1.5 ppm	N/A*
	24.235	0.05 ppm	N/A*

* These items are NOT applied to the EUT.

** See page 10.

The estimated uncertainty of the test result is given as following. The method of uncertainty calculation is provided in Advanced Compliance Lab. Doc. No. 0048-01-01.

	Prob. Dist.	Uncertainty(dB) 30-1000MHz	Uncertainty(dB) 1-6.5GHz	Uncertainty(dB) Conducted
Combined Std. Uncertainty u_c	norm.	± 2.36	± 2.99	± 1.83



Wei Li
Lab Manager
Advanced Compliance Lab

Date: March 21, 2008

Section 2. General Equipment Specification

Supply Voltage	27V(+18V to +30V)				
Frequency Range	Cellular	N/A			
	PCS	DL/ 1930 – 1960 MHz			
Modulation	<input checked="" type="checkbox"/> CDMA	<input type="checkbox"/> WCDMA	<input type="checkbox"/> GSM	<input type="checkbox"/> EDGE	<input type="checkbox"/> TDMA
Type of Emissions	F9W	F9W	GXW	G7W	DXW
Rated Power	75W average Composite				
Operating Power	37.5W/carrier for 2 Carrier CDMA 25W/carrier for 3 Carrier CDMA				
Output Impedance	50ohm				
Frequency Translation	F1-F1 <input checked="" type="checkbox"/>	F1-F2 <input type="checkbox"/>	N/A <input type="checkbox"/>		
	Software <input type="checkbox"/>	Duplexer Change <input type="checkbox"/>	Full Band Coverage <input checked="" type="checkbox"/>		

DC voltages and DC currents per 2.1033(c)(8)

The input supply to the transmitter was set at 27 Volts DC. The RF power output was measured with the indicated voltage and current applied into the final RF amplifying device(s).

RF100978 Amplifier

RF Output, DC Current and RF Input Power are all average values.

Measured Rated RF output: 48.75dBm (75W)

Measured DC voltage: 27.0V

Measured DC current: 12.1A.

Measured Minimum RF output: 15.9dBm (38mW)

Measured DC voltage: 27.0V

Measured DC current: 2.98A

Tune-up procedure per 2.1033(c) (9)

There are no user accessible adjustments or tuning in this amplifier. All necessary adjustments and tuning are performed during manufacture of the product. Any adjustments or tuning after service or repair are done as part of that process as special equipment is required to perform such adjustments.

Description of Operation

This device is a multi-carrier power amplifier used in BTS in downlink spectrum of 1900MHz PCS band. All measurements shall be made at room temperature and at nominal DC input voltage.

System Diagram

See Attachment.

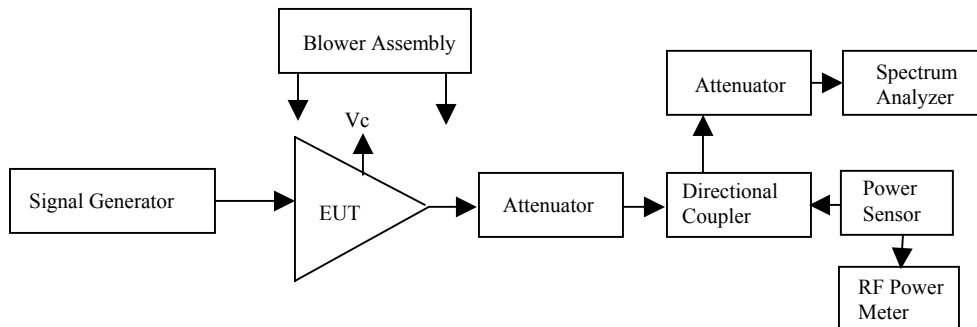
General EUT Setup

Section 3. RF Output Power

Name of Test:	<i>RF Output Power</i>	Test Standard:	22.913(a) 24.232(a)
Tested By:	WEI LI	Test Date:	03/11/2008-03/21/2008

Minimum Standard: Para. No. 22.913(a). The maximum effective radiated power (ERP) of base station transmitters and cellular repeaters must not exceed 500 Watts (57dBm).

Para. No. 24.232(a). The maximum peak output power of base transmitters should not exceed 100 Watts EIRP (50dBm).

Method of Measurement: The EUT is a RF amplifier. The manufacturer does not provide an antenna for sale with the product, hence EIRP is not measured nor calculated.

Per 2.1046: The RF Power Output shall be measured at the output connector of the EUT. The output level shall be +48.75 dBm (75 watts) +1 dB, -3 dB over the PCS frequency band: 1930-1990 MHz. The tolerance range is per TIA/EIA-97-D, Section 4.3.1.3.

Using power meter, power measurements shall be taken at the low band edge, mid, and high band edge frequencies for all modulations listed on Page 5.

Test Result:

Complies

Test Data:

Rated Output Power – Normal Condition

The inputs are set to generate rated average output power and crest factor for the multi-carrier signals intended.

PCS Band	Channel	Modulation	Power Output (dBm)	Rated Power (dBm)	Tolerance
Downlink	Low	CDMA	48.72	48.75	-0.03
	Mid	CDMA	48.75	48.75	0
	High	CDMA	48.64	48.75	-0.11
Total Power at Amplifier RF Input (dBm)	0.96 (Maximum gain)				
Ref Offset	Ref offset=Cable&Attenuator&Coupler Attenuation=46.3dB				

Conclusion:

The total rated RF power is 75W for multiple-carrier operation. As indicated on Page 5, supported output power per carrier is 37.5W for 2 CDMA Carriers and 25W for 3 CDMA Carriers, which does not exceed the 100 Watt peak power limit.

Section 4. Occupied Bandwidth

Name of Test:	<i>Occupied Bandwidth</i>	Test Standard:	<i>2.1049(i)</i>
Tested By:	WEI LI	Test Date:	03/11/2008-03/21/2008

Minimum Standard: Not defined by FCC. Input vs. Output.

Method of Measurement: Spectrum Analyzer Settings:
 RBW: CDMA (30 kHz), WCDMA (100KHz), CDMA(30KHz), GSM (3 kHz), EDGE (3KHz), NADC (1 kHz) and CDPD (1 kHz)
 VBW: \geq RBW
 Span: As required
 Sweep: Auto
 Input Signal Characteristics: Generated from Signal Generator
 RF level: Rated, recommended by manufacturer

Test Result:

Complies

Test Data:

Attached Plots

Project Number:	0048-080310-01
EUT:	ANDREW 1960 CDMA Multiple Carrier Power Amplifier RF100978
S/N:	PT004
Tested By:	Wei Li
Temperature:	70° F
Humidity:	30%

Section:	Occupied Bandwidth: PCS Bands
Plot Name:	Downlink, Hi-Channel, CDMA Modulation
Configuration:	Input: SG, Output Port: EUT RF OUTPUT

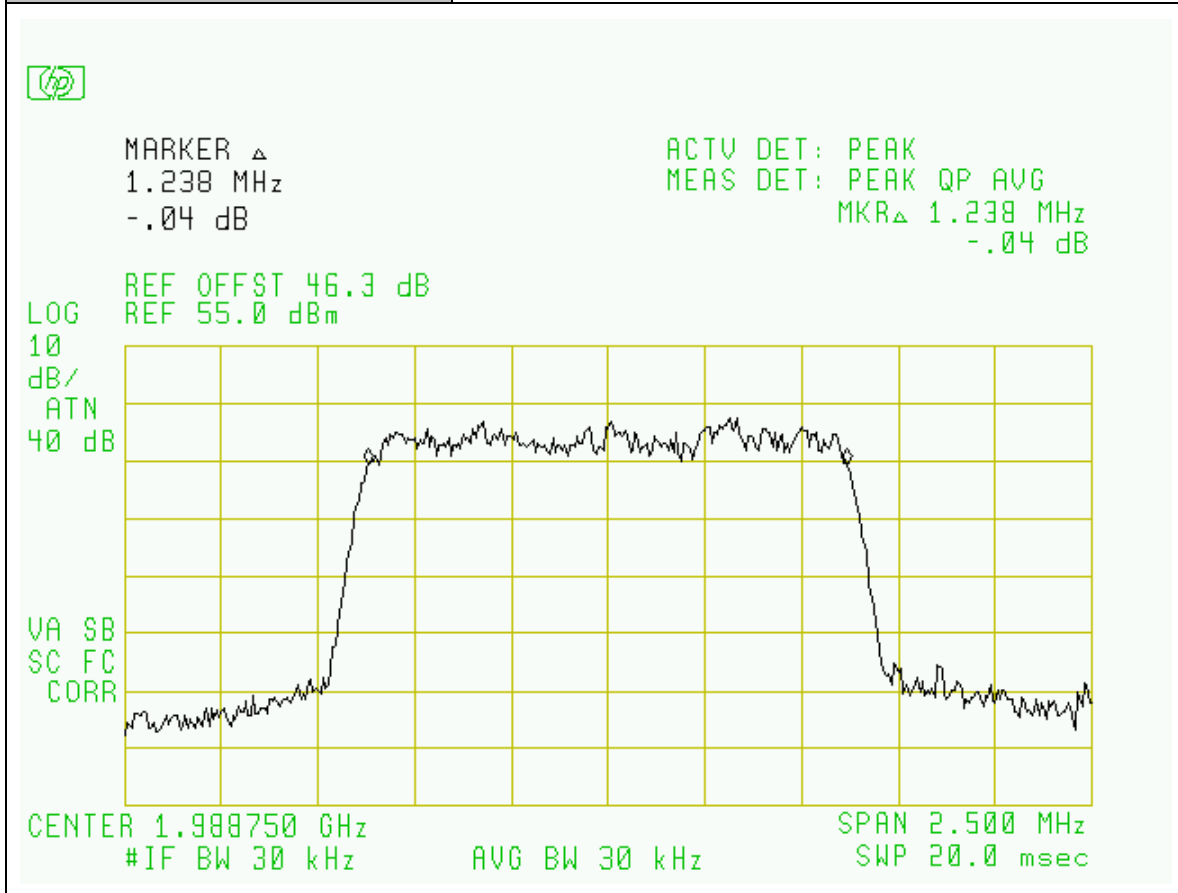

Project Number:	0048-080310-01
EUT:	ANDREW 1960 CDMA Multiple Carrier Power Amplifier RF100978
S/N:	PT004
Tested By:	Wei Li
Temperature:	70° F
Humidity:	30%

Section:	Occupied Bandwidth: PCS Bands
Plot Name:	Downlink, Hi-Channel, CDMA Modulation
Configuration:	Input: SG

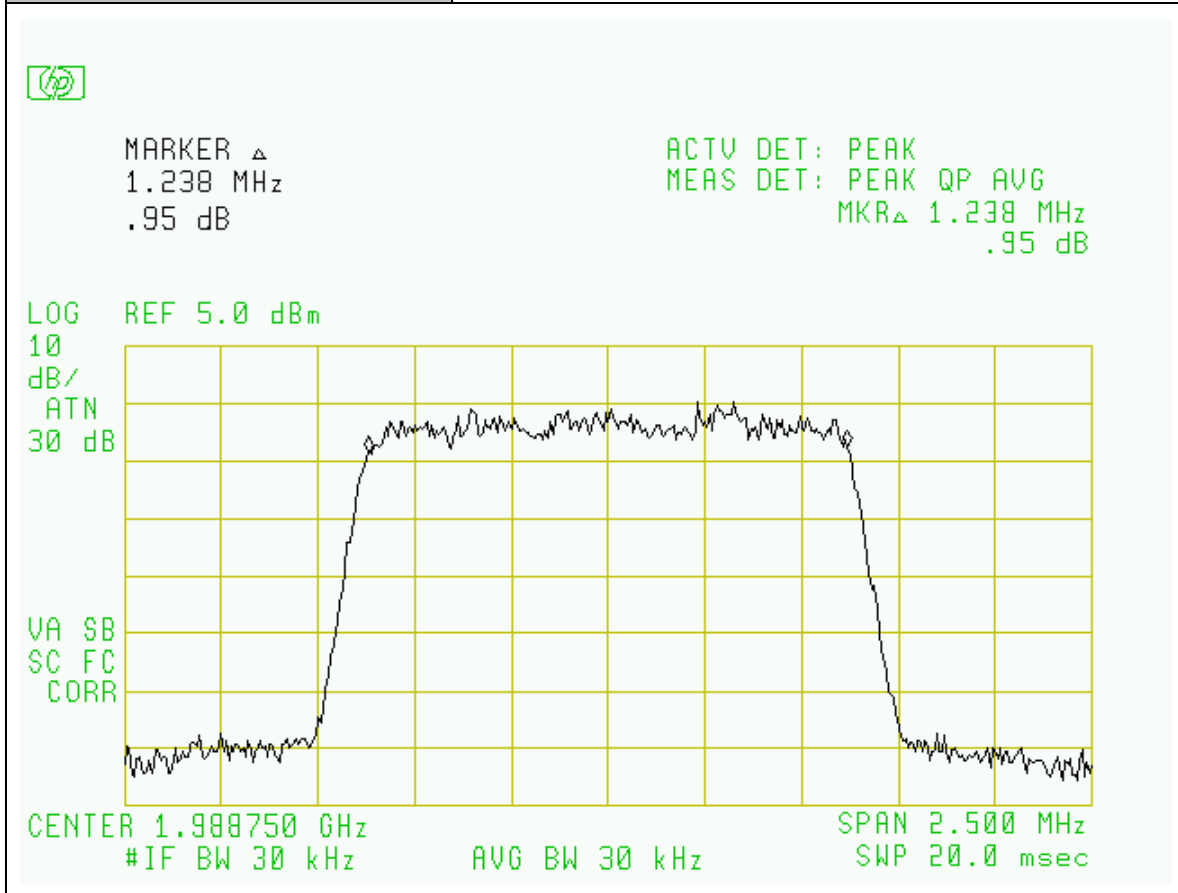

Project Number:	0048-080310-01
EUT:	ANDREW 1960 CDMA Multiple Carrier Power Amplifier RF100978
S/N:	PT004
Tested By:	Wei Li
Temperature:	70° F
Humidity:	30%

Section:	Occupied Bandwidth: PCS Bands
Plot Name:	Downlink, Mid-Channel, CDMA Modulation
Configuration:	Input: SG, Output Port: EUT RF OUTPUT

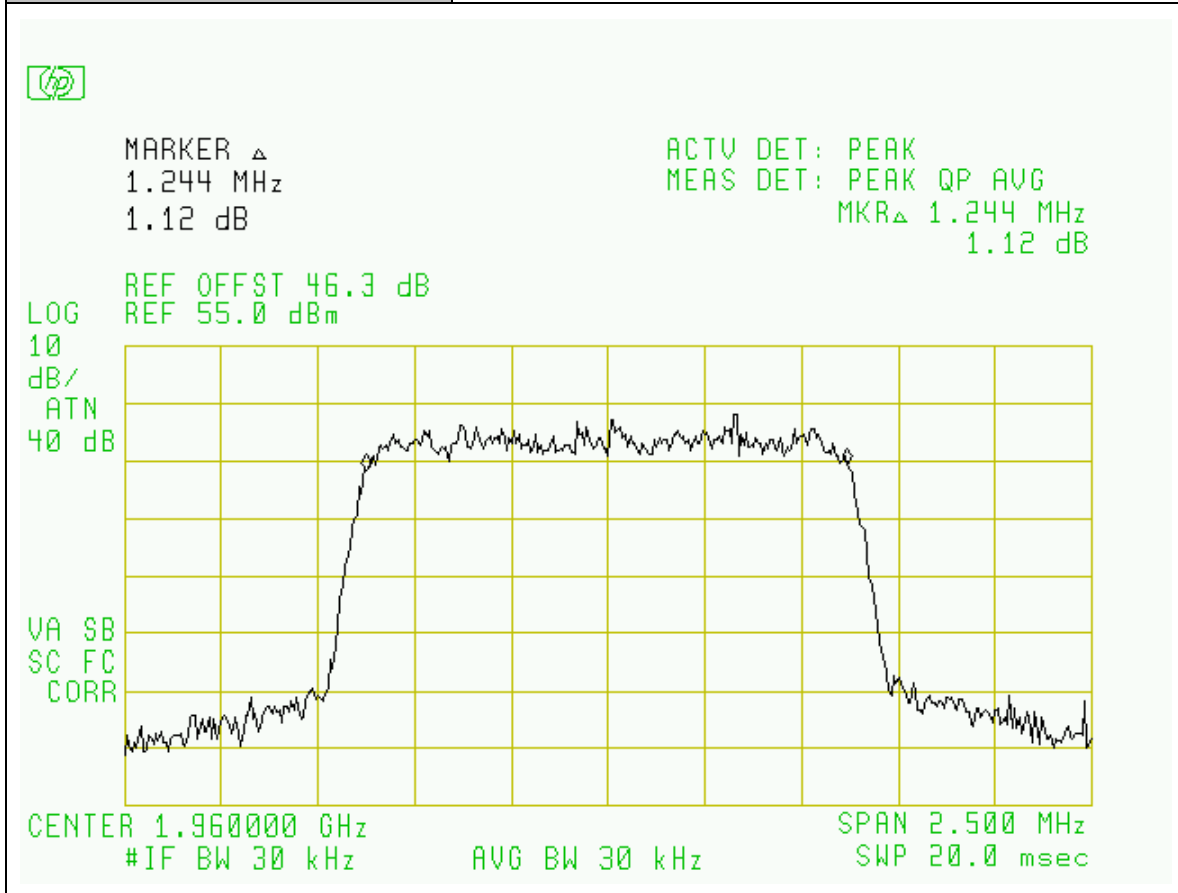

Project Number:	0048-080310-01
EUT:	ANDREW 1960 CDMA Multiple Carrier Power Amplifier RF100978
S/N:	PT004
Tested By:	Wei Li
Temperature:	70° F
Humidity:	30%

Section:	Occupied Bandwidth: PCS Bands
Plot Name:	Downlink, Mid-Channel, CDMA Modulation
Configuration:	Input: SG

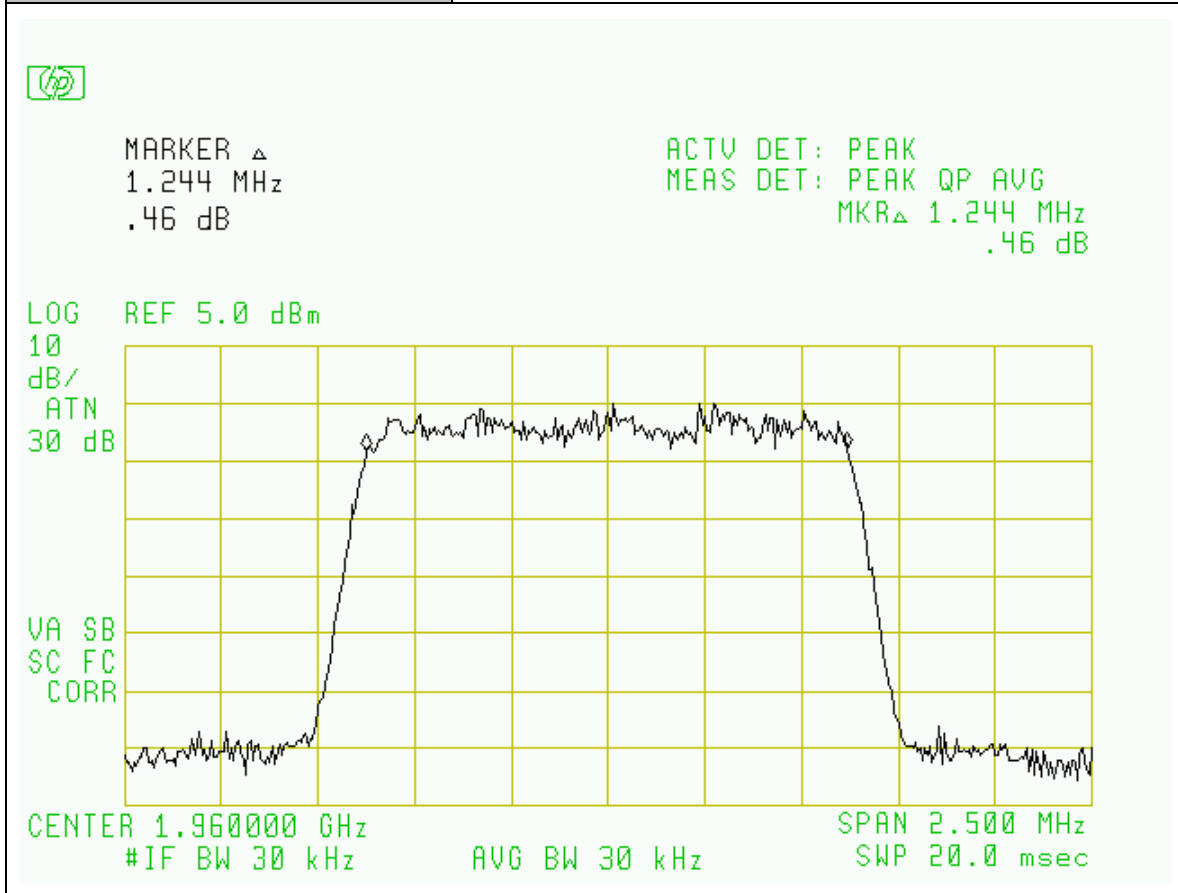

Project Number:	0048-080310-01
EUT:	ANDREW 1960 CDMA Multiple Carrier Power Amplifier RF100978
S/N:	PT004
Tested By:	Wei Li
Temperature:	70° F
Humidity:	30%

Section:	Occupied Bandwidth: PCS Bands
Plot Name:	Downlink, Low-Channel, CDMA Modulation
Configuration:	Input: SG, Output Port: EUT RF OUTPUT

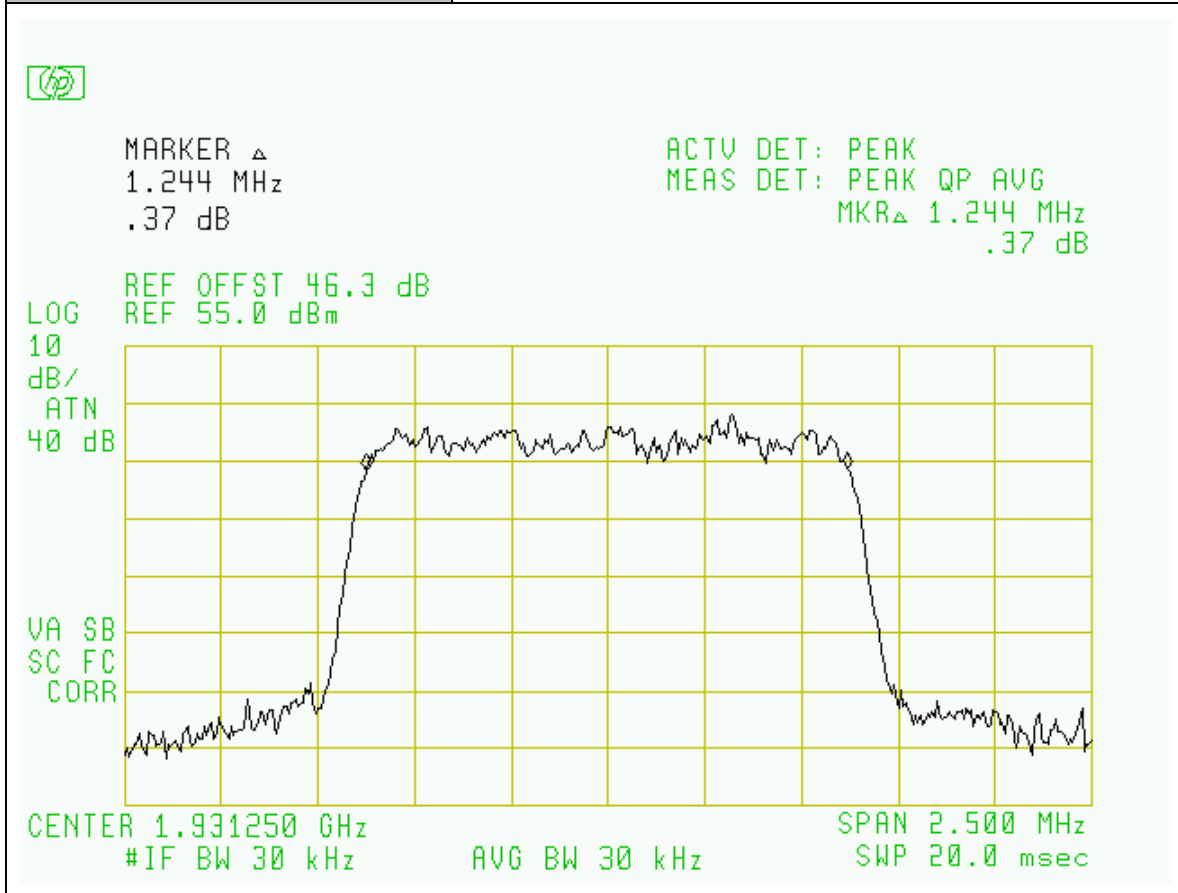

Project Number:	0048-080310-01
EUT:	ANDREW 1960 CDMA Multiple Carrier Power Amplifier RF100978
S/N:	PT004
Tested By:	Wei Li
Temperature:	70° F
Humidity:	30%

Section:	Occupied Bandwidth: PCS Bands
Plot Name:	Downlink, Low-Channel, CDMA Modulation
Configuration:	Input: SG

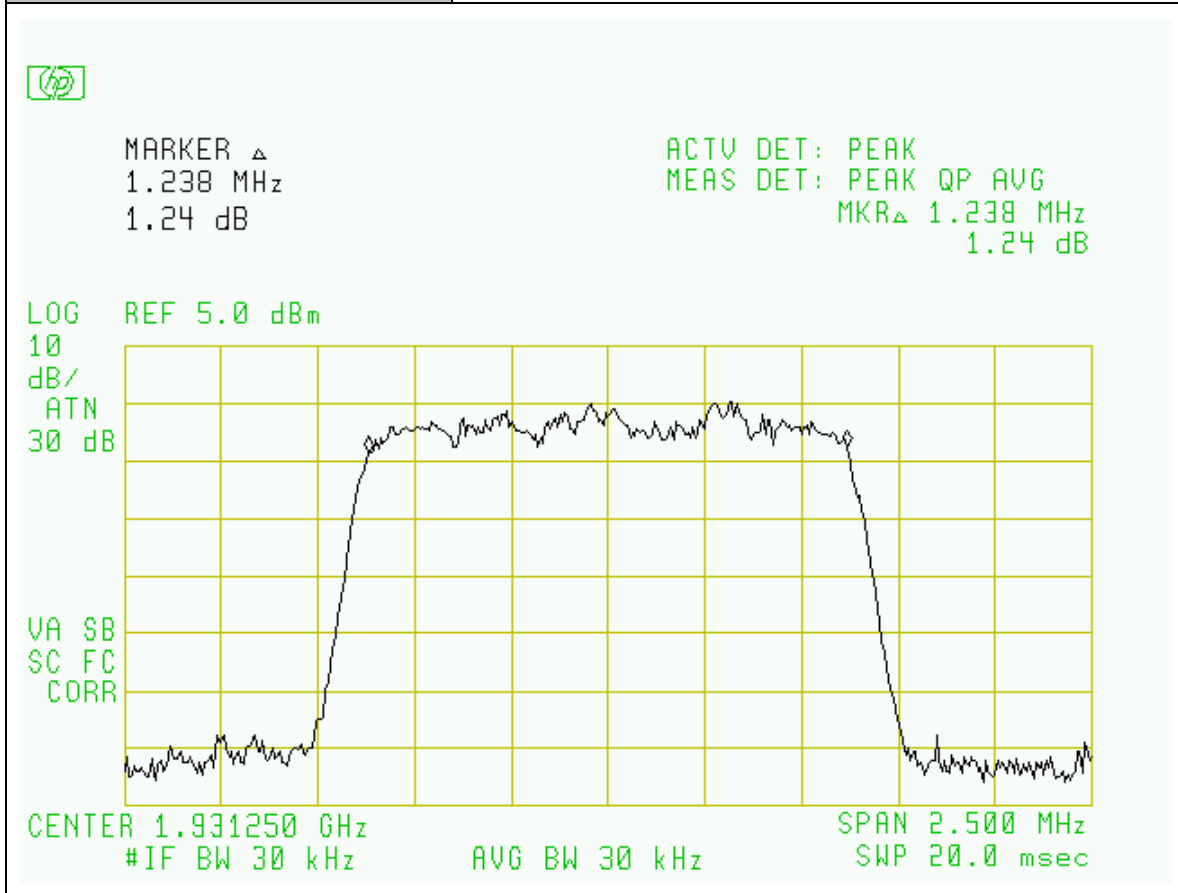

Section 5. Spurious Emissions at Antenna Terminals

Name of Test:	<i>Spurious Emissions at Antenna Terminals</i>	Test Standard:	22.917 24.238(a)
Tested By:	WEI LI EDWARD LEE	Test Date:	03/11/2008-03/21/2008

Minimum Standard: Para. No. 22.917(e). The mean power of emissions must be attenuated below the mean power of the unmodulated carrier on any frequency twice or more than twice the fundamental emission by at least $43 + 10 \log P$. This is equivalent to -13 dBm absolute power.

Para. No. 24.238(a). The magnitude of each spurious and harmonic emission that can be detected when the equipment is operated under conditions specified in the instruction manual and/or alignment procedure, shall not less than $43+10 \log$ (mean output power in watts) dBc below the mean power output outside a licensee's frequency block (-13dBm).

Method of Measurement: Spectrum Analyzer Settings:
 RBW: 100 kHz. As required for digital modulations.
 RBW: 1MHz. When frequency is located above 1GHz.
 VBW: \geq RBW
 Start Frequency: 9KHz or Lowest Clock Frequency
 Stop Frequency: 10 GHz (Cellular), 20GHz (PCS)
 Sweep: Auto
 Using in-band filter if needed.
 For Inter-modulation measurement: Three RF signals set as inputs. The frequencies of RF signals shall be within the repeater's operating band: two signals will close to each other at the lower band edge; the third will be close to upper band edge. The level of both RF input signals shall be increased, until the maximum rated output power per channel, as declared by the manufacturer (CDMA: 75W composite, 37.5W per carrier), is reached.

* Out of band plots show nearly identical noise floor readings for the frequency ranges below 20MHz and above 6.5GHz.

Test Result:

Complies

Test Data:

Attached Plots

Project Number:	0048-080310-01
EUT:	ANDREW 1960 CDMA Multiple Carrier Power Amplifier RF100978
S/N:	PT004
Tested By:	Edward Lee
Temperature:	70 °F
Humidity:	30%

Section:	Spurious Emissions at RF Output Port: PCS Bands / CDMA Modulation
Plot Name:	Downlink, H-CH Inter-modulation
Configuration:	Input: SG, Output Port: EUT RF OUTPUT

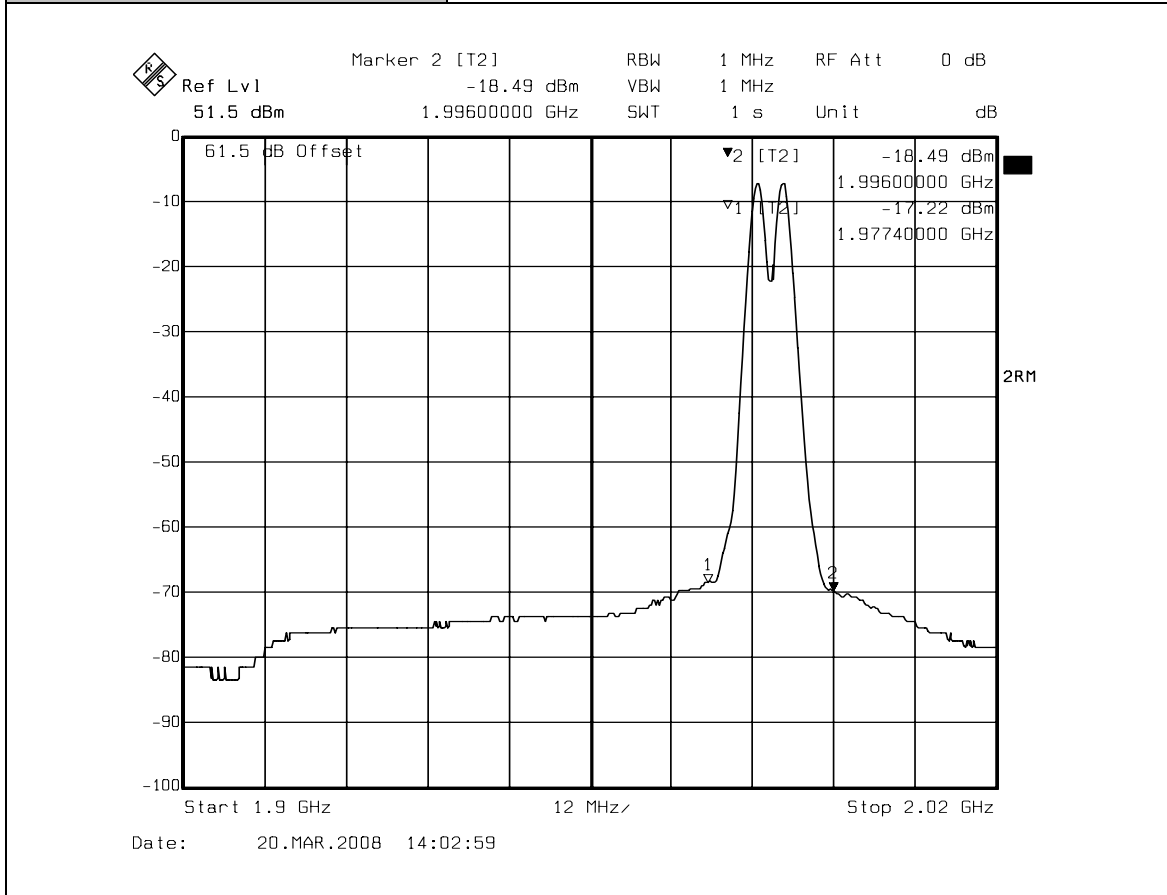

Project Number:	0048-080310-01
EUT:	ANDREW 1960 CDMA Multiple Carrier Power Amplifier RF100978
S/N:	PT004
Tested By:	Edward Lee
Temperature:	70° F
Humidity:	30%

Section:	Spurious Emissions at RF Output Port: PCS Bands / WCDMA Modulation
Plot Name:	Downlink, Mid CH Inter-modulation
Configuration:	Input: SG, Output Port: EUT RF OUTPUT

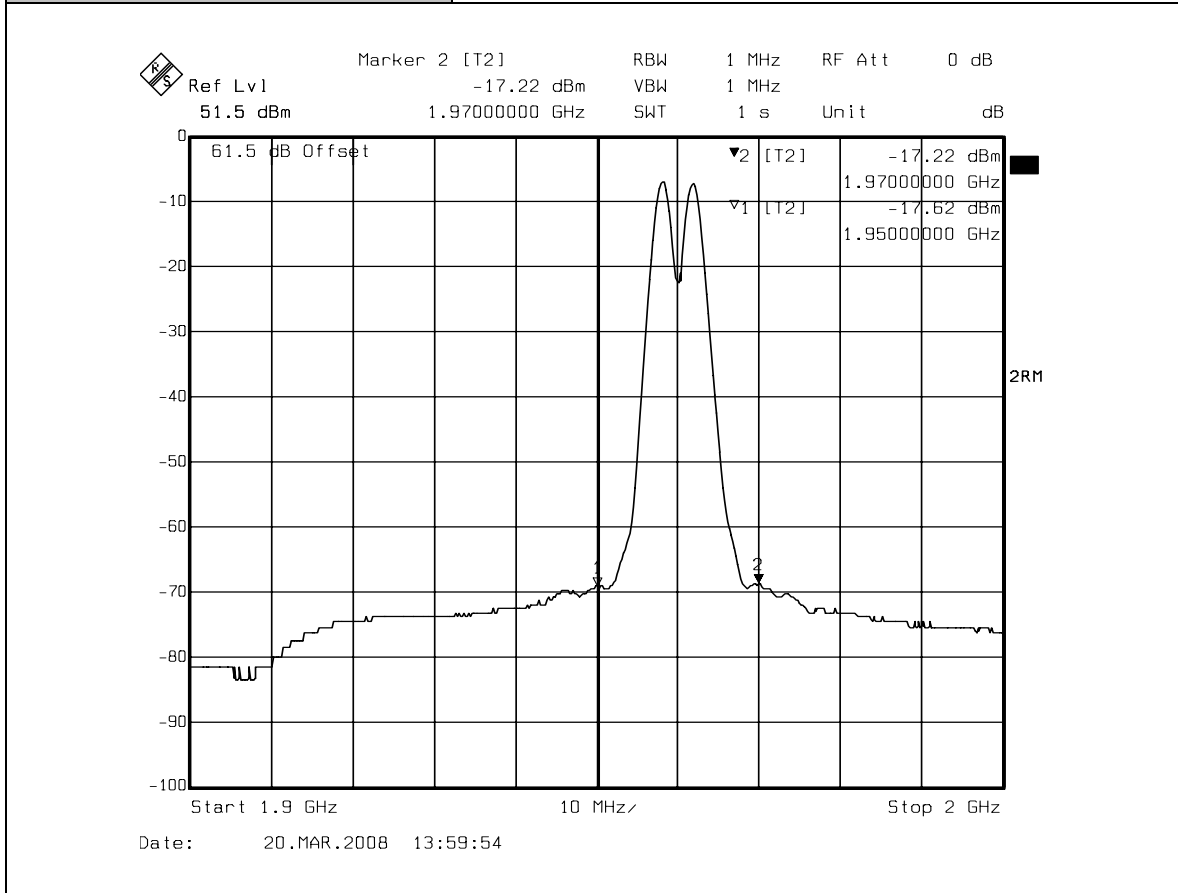

Project Number:	0048-080310-01
EUT:	ANDREW 1960 CDMA Multiple Carrier Power Amplifier RF100978
S/N:	PT004
Tested By:	Edward Lee
Temperature:	70° F
Humidity:	30%

Section:	Spurious Emissions at RF Output Port: PCS Bands / GSM Modulation
Plot Name:	Downlink, L-CH Inter-modulation
Configuration:	Input: SG, Output Port: EUT RF OUTPUT

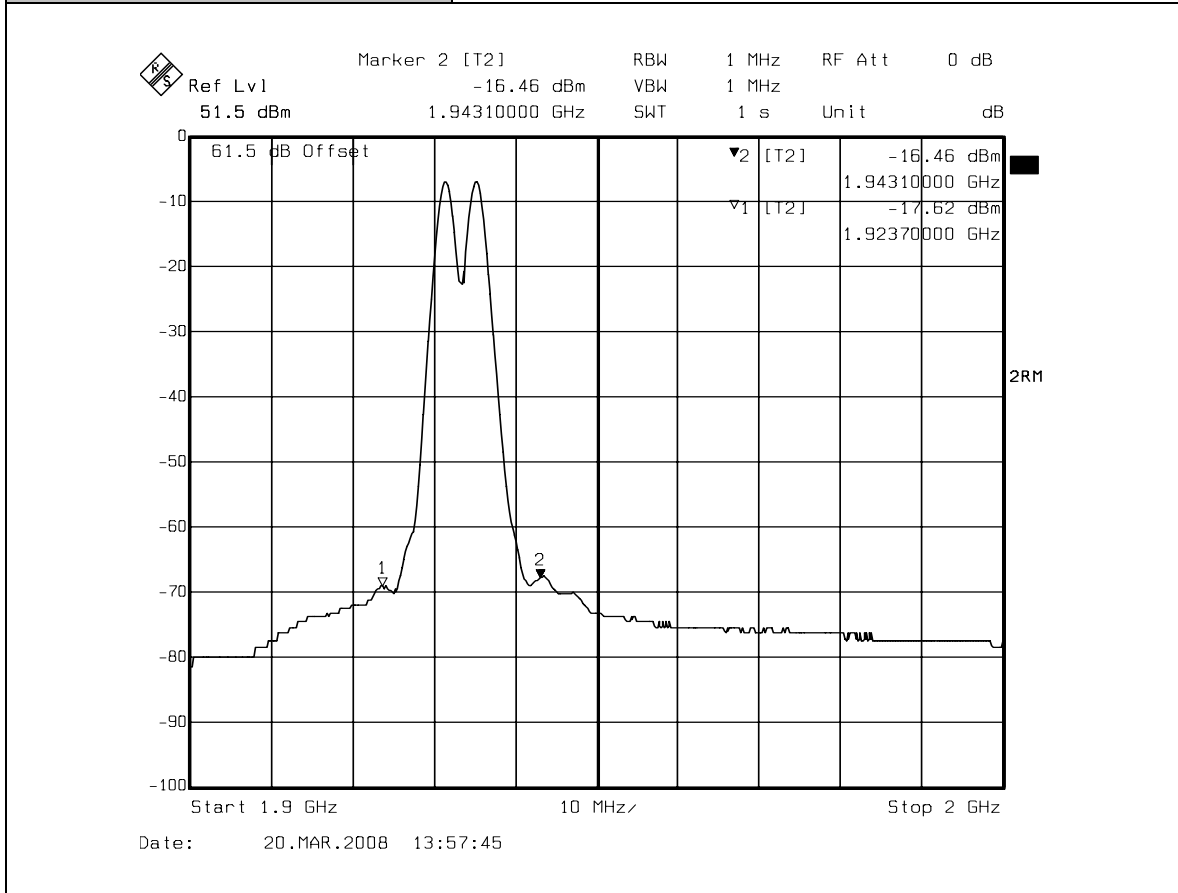

Project Number:	0048-080310-01
EUT:	ANDREW 1960 CDMA Multiple Carrier Power Amplifier RF100978
S/N:	PT004
Tested By:	Edward Lee
Temperature:	70° F
Humidity:	30%

Section:	Spurious Emissions at RF Output Port: PCS Bands / CDMA Modulation
Plot Name:	Downlink, Low-Chn, Lower Bandedge
Configuration:	Input: SG, Output Port: EUT RF OUTPUT

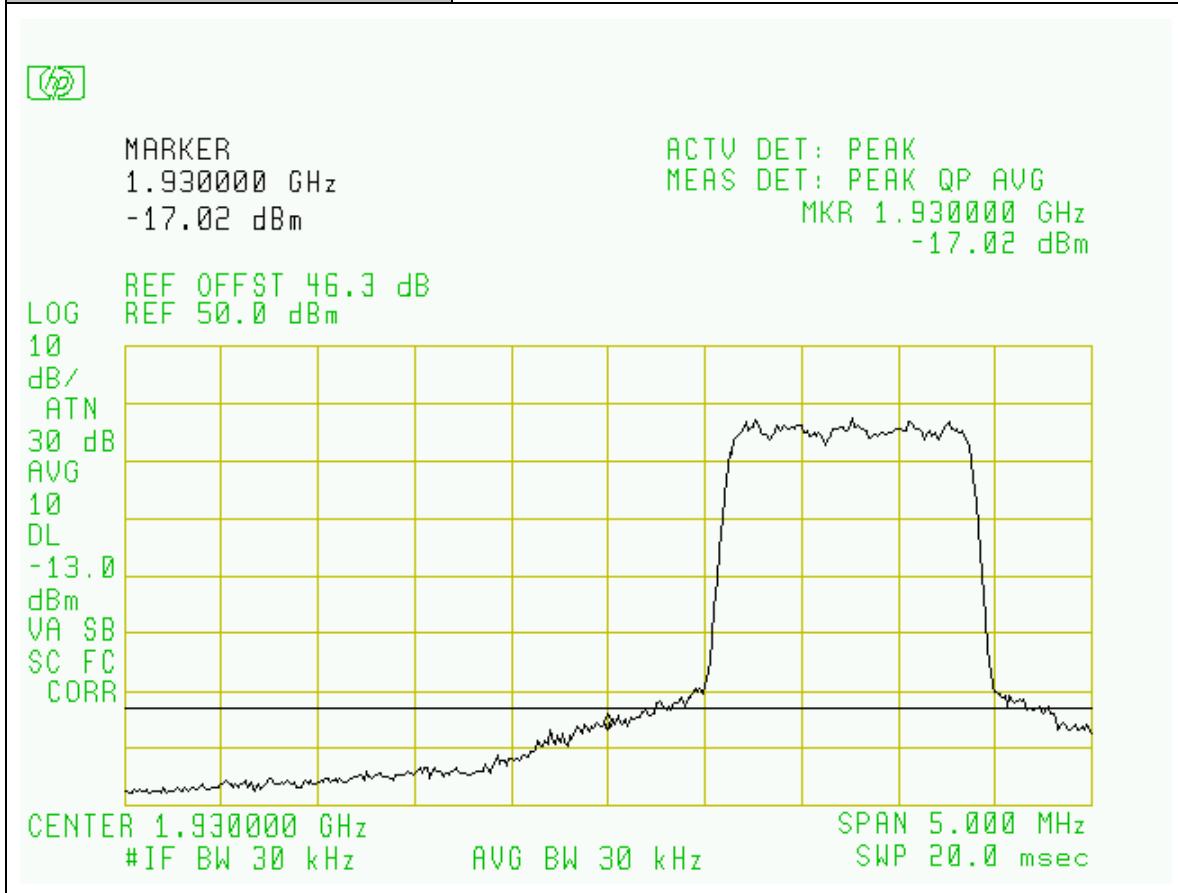

Project Number:	0048-080310-01
EUT:	ANDREW 1960 CDMA Multiple Carrier Power Amplifier RF100978
S/N:	PT004
Tested By:	Edward Lee
Temperature:	70° F
Humidity:	30%

Section:	Spurious Emissions at RF Output Port: PCS Bands / CDMA Modulation
Plot Name:	Downlink, Hi-Chn, Upper Bandedge
Configuration:	Input: SG, Output Port: EUT RF OUTPUT

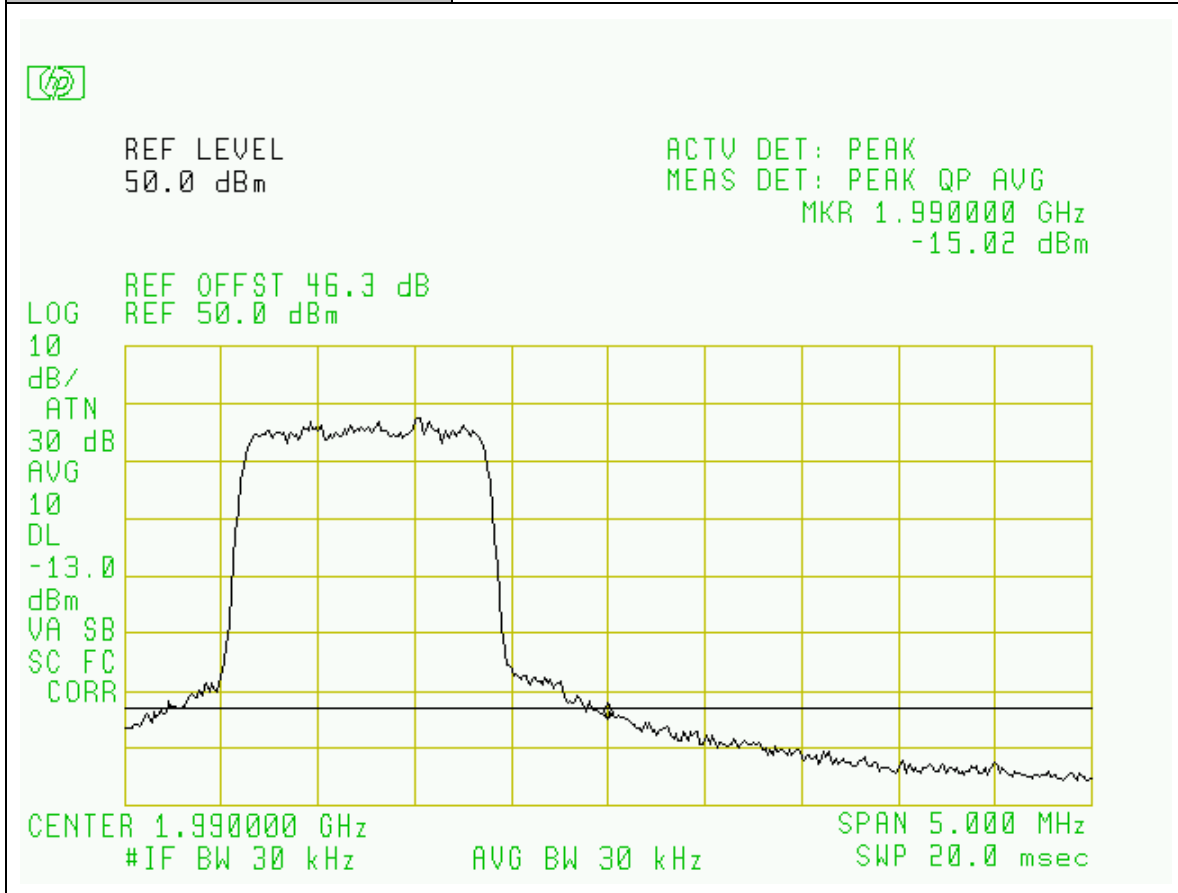

Project Number:	0048-080310-01
EUT:	ANDREW 1960 CDMA Multiple Carrier Power Amplifier RF100978
S/N:	PT004
Tested By:	Wei Li
Temperature:	70°F
Humidity:	30%

Section:	Spurious Emissions at RF Output Port: PCS Bands / CDMA Modulation
Plot Name:	Downlink, Hi-Channel
Configuration:	Input: SG, Output Port: EUT RF OUTPUT

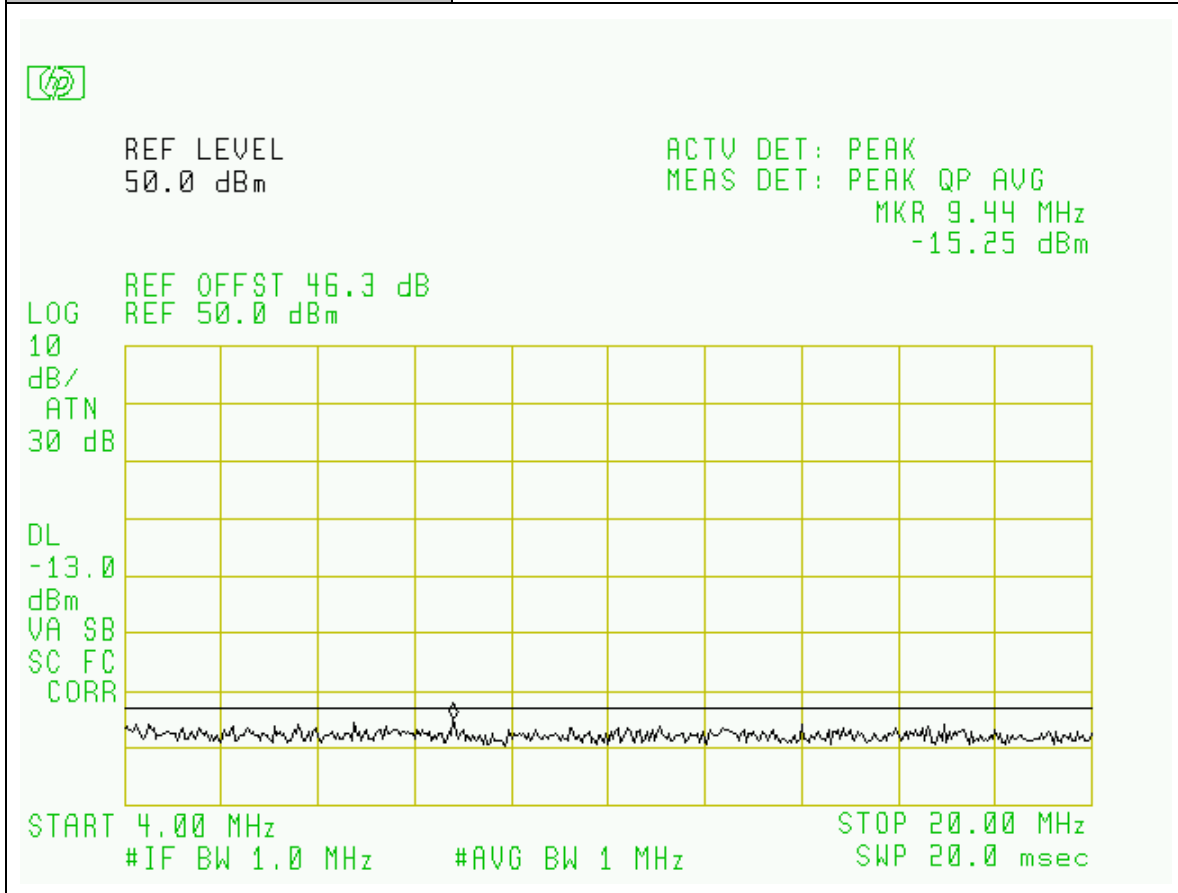

Project Number:	0048-080310-01
EUT:	ANDREW 1960 CDMA Multiple Carrier Power Amplifier RF100978
S/N:	PT004
Tested By:	Wei Li
Temperature:	70°F
Humidity:	30%

Section:	Spurious Emissions at RF Output Port: PCS Bands / CDMA Modulation
Plot Name:	Downlink, Hi-Channel
Configuration:	Input: SG, Output Port: EUT RF OUTPUT

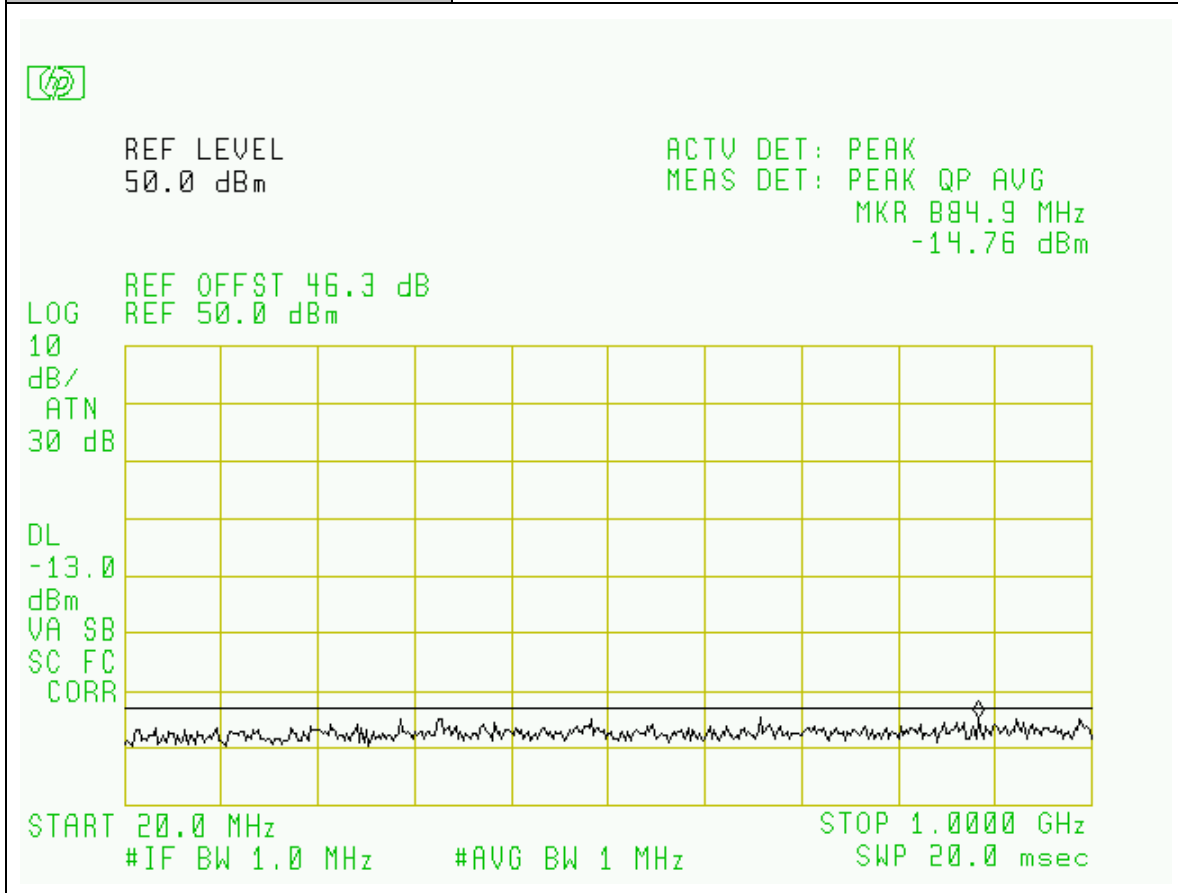

Project Number:	0048-080310-01
EUT:	ANDREW 1960 CDMA Multiple Carrier Power Amplifier RF100978
S/N:	PT004
Tested By:	Wei Li
Temperature:	70° F
Humidity:	30%

Section:	Spurious Emissions at RF Output Port: PCS Bands / CDMA Modulation
Plot Name:	Downlink, Hi-Channel
Configuration:	Input: SG, Output Port: EUT RF OUTPUT

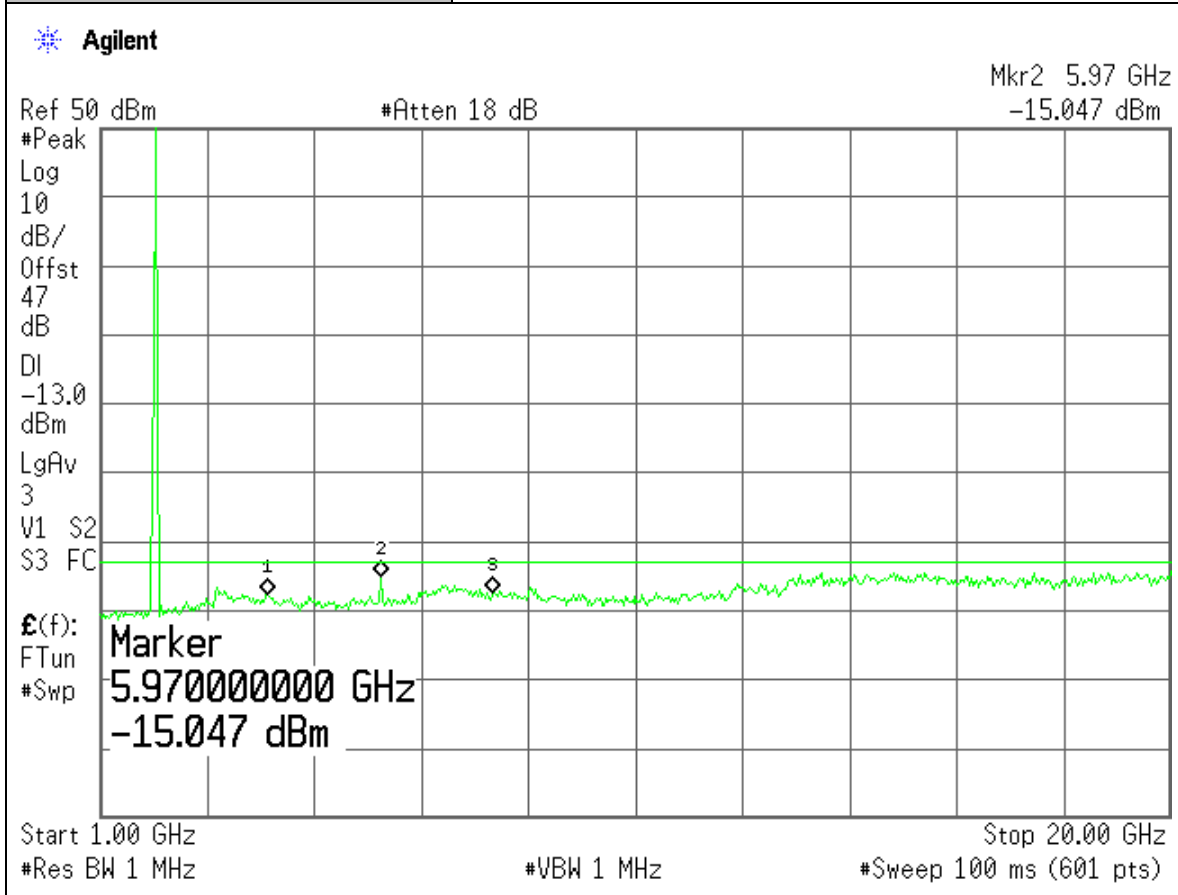

Project Number:	0048-080310-01
EUT:	ANDREW 1960 CDMA Multiple Carrier Power Amplifier RF100978
S/N:	PT004
Tested By:	Wei Li
Temperature:	70°F
Humidity:	30%

Section:	Spurious Emissions at RF Output Port: PCS Bands / CDMA Modulation
Plot Name:	Downlink, Mid-Channel
Configuration:	Input: SG, Output Port: EUT RF OUTPUT

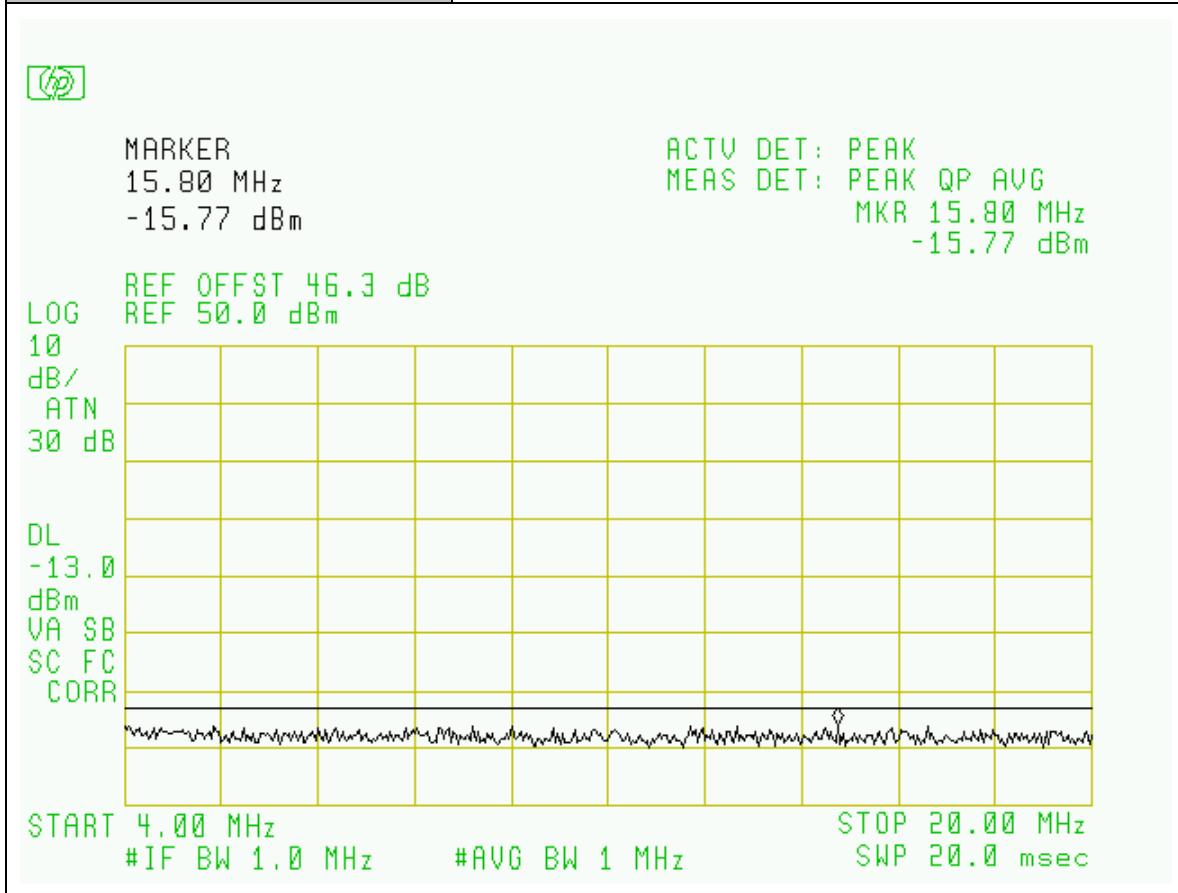

Project Number:	0048-080310-01
EUT:	ANDREW 1960 CDMA Multiple Carrier Power Amplifier RF100978
S/N:	PT004
Tested By:	Wei Li
Temperature:	70° F
Humidity:	30%

Section:	Spurious Emissions at RF Output Port: PCS Bands / CDMA Modulation
Plot Name:	Downlink, Mid-Channel
Configuration:	Input: SG, Output Port: EUT RF OUTPUT

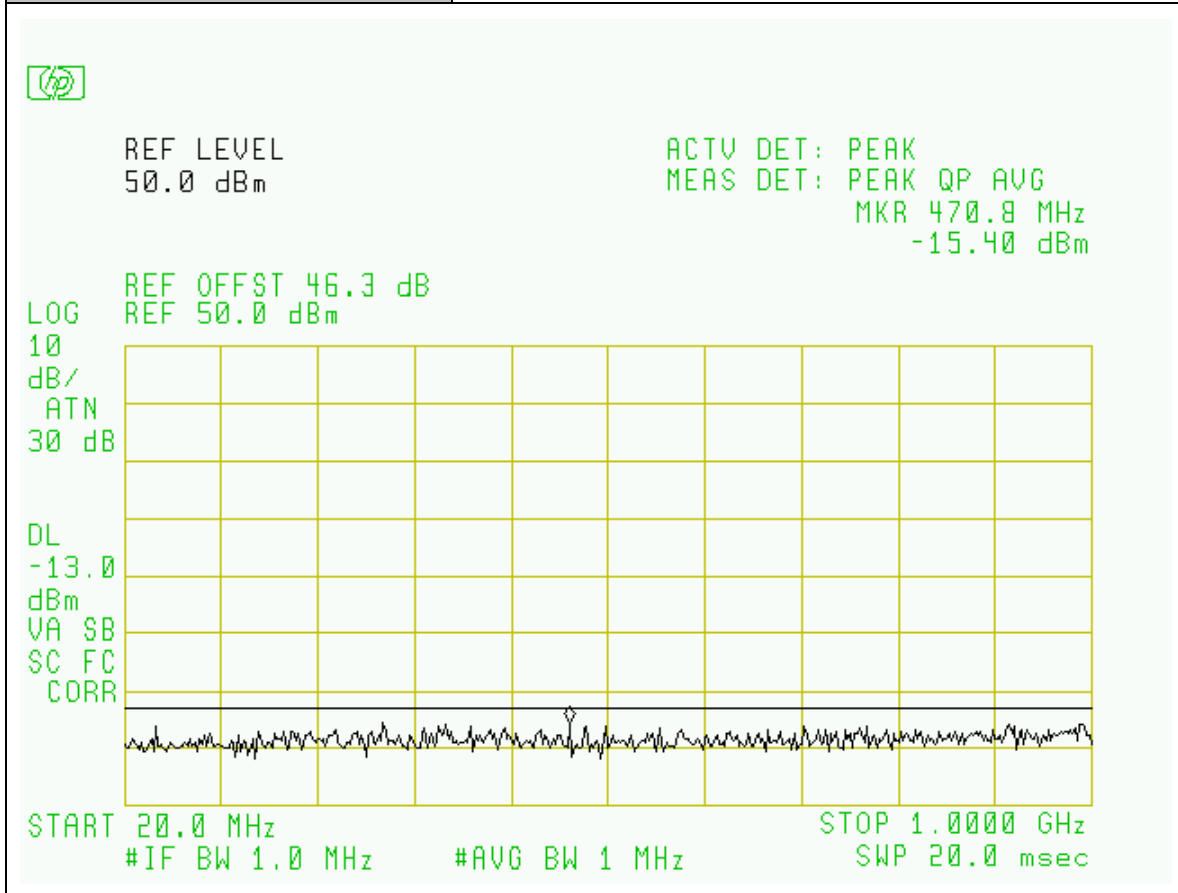

Project Number:	0048-080310-01
EUT:	ANDREW 1960 CDMA Multiple Carrier Power Amplifier RF100978
S/N:	PT004
Tested By:	Wei Li
Temperature:	70° F
Humidity:	30%

Section:	Spurious Emissions at RF Output Port: PCS Bands / CDMA Modulation
Plot Name:	Downlink, Mid-Channel
Configuration:	Input: SG, Output Port: EUT RF OUTPUT

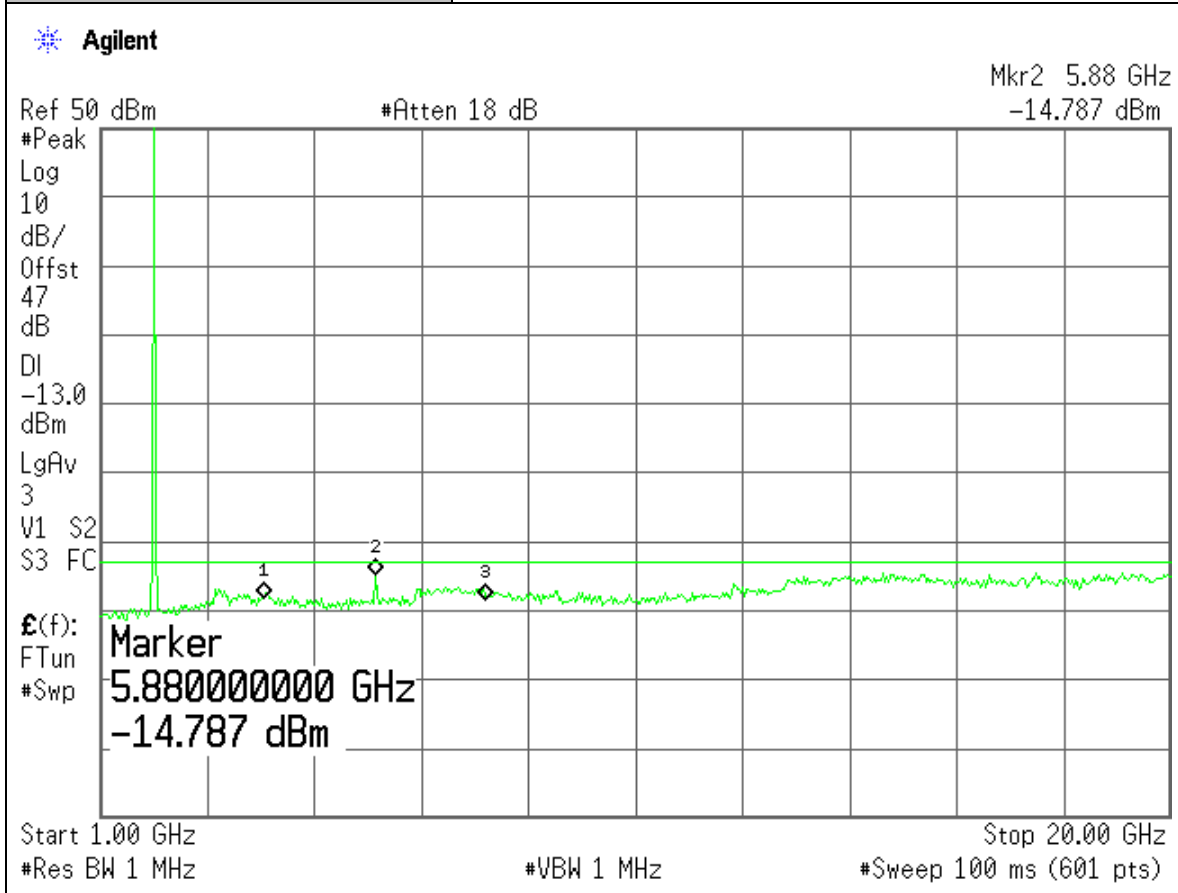

Project Number:	0048-080310-01
EUT:	ANDREW 1960 CDMA Multiple Carrier Power Amplifier RF100978
S/N:	PT004
Tested By:	Wei Li
Temperature:	70°F
Humidity:	30%

Section:	Spurious Emissions at RF Output Port: PCS Bands / CDMA Modulation
Plot Name:	Downlink, Low-Channel
Configuration:	Input: SG, Output Port: EUT RF OUTPUT

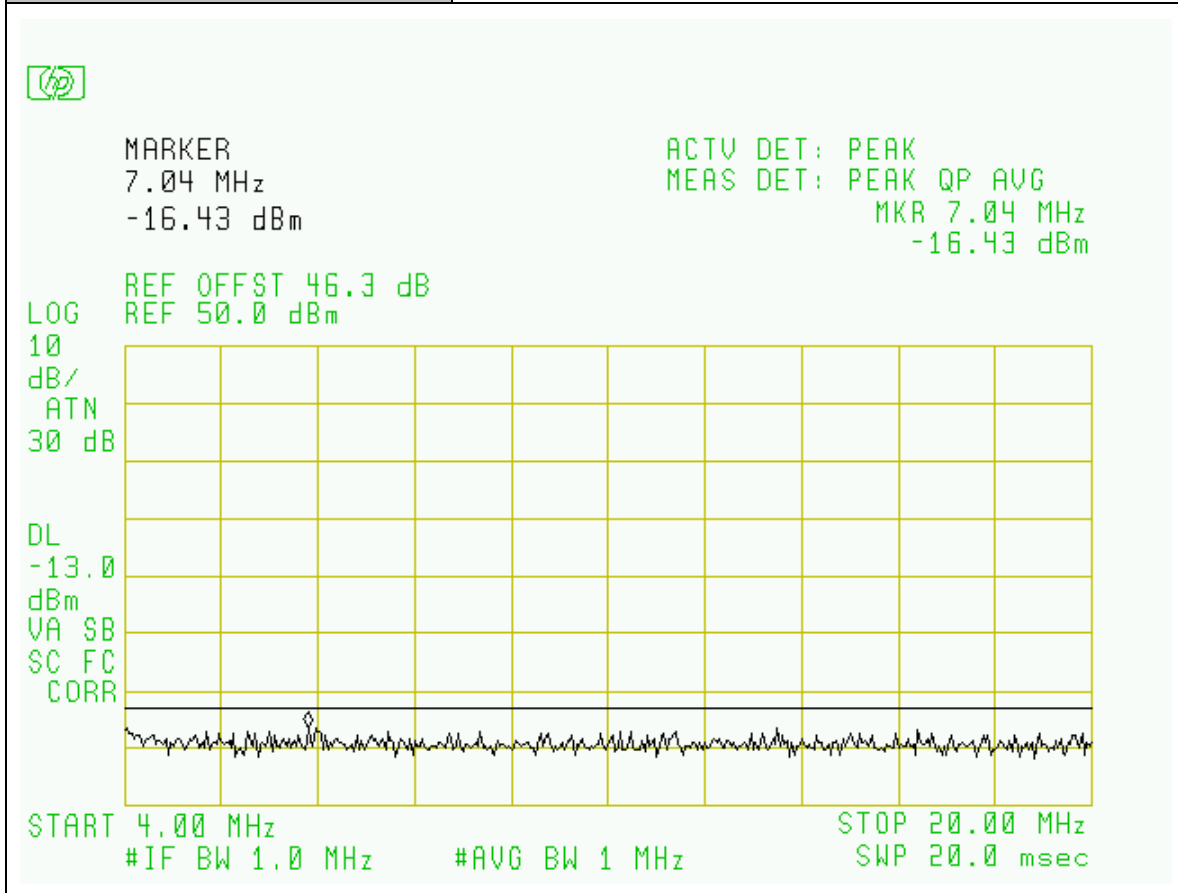

Project Number:	0048-080310-01
EUT:	ANDREW 1960 CDMA Multiple Carrier Power Amplifier RF100978
S/N:	PT004
Tested By:	Wei Li
Temperature:	70°F
Humidity:	30%

Section:	Spurious Emissions at RF Output Port: PCS Bands / CDMA Modulation
Plot Name:	Downlink, Low-Channel
Configuration:	Input: SG, Output Port: EUT RF OUTPUT

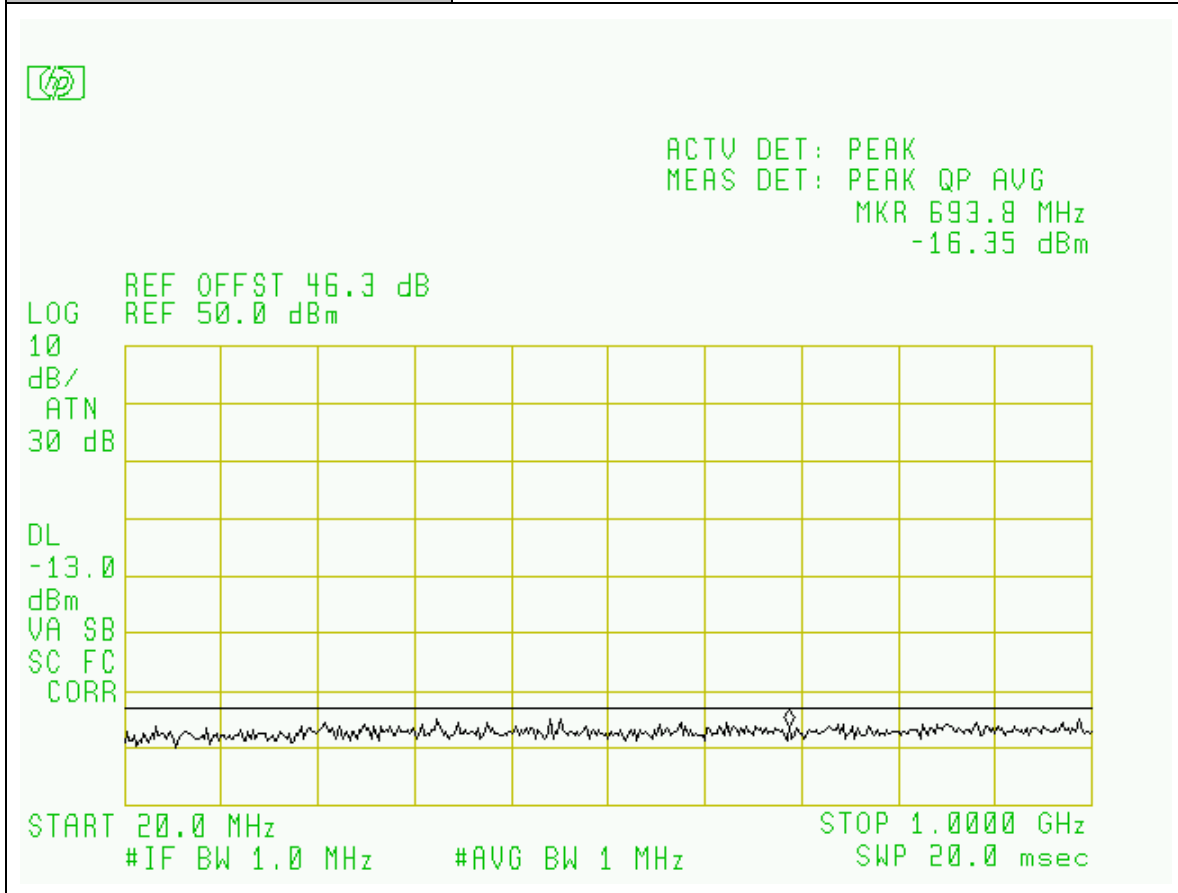

Project Number:	0048-080310-01
EUT:	ANDREW 1960 CDMA Multiple Carrier Power Amplifier RF100978
S/N:	PT004
Tested By:	Wei Li
Temperature:	70° F
Humidity:	30%

Section:	Spurious Emissions at RF Output Port: PCS Bands / CDMA Modulation
Plot Name:	Downlink, Low-Channel
Configuration:	Input: SG, Output Port: EUT RF OUTPUT

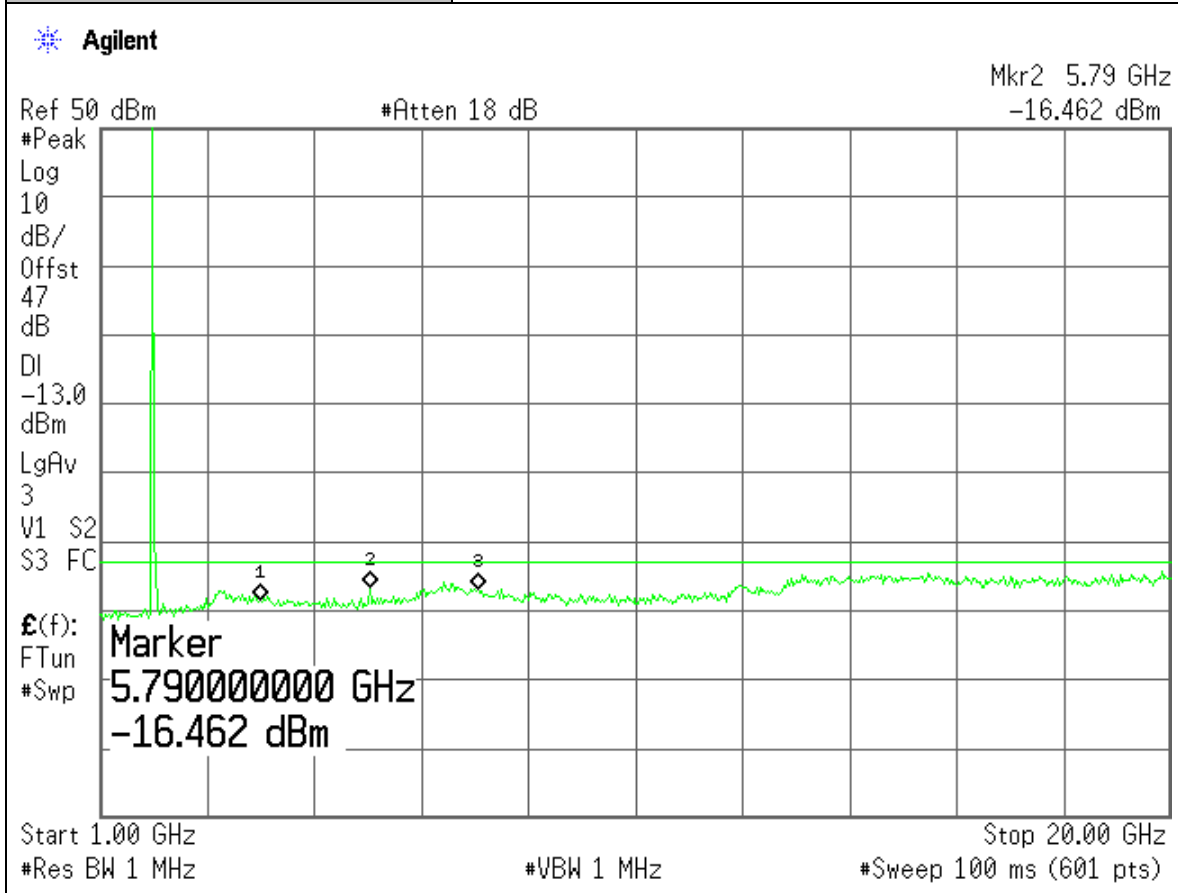

Section 6. Field Strength of Spurious

Name of Test:	<i>Field Strength of Spurious</i>	Test Standard:	22.917 24.238
Tested By:	EDWARD LEE	Test Date:	03/11/2008-03/21/2008

Minimum Standard: Para. No. 22.917(e). The mean power of emissions must be attenuated below the mean power of the unmodulated carrier on any frequency twice or more than twice the fundamental emission by at least $43 + 10 \log P$. This is equivalent to -13 dBm absolute power. Para. No. 24.238(a). The magnitude of each spurious and harmonic emission that can be detected when the equipment is operated under conditions specified in the instruction manual and/or alignment procedure, shall not less than $43+10 \log$ (mean output power in watts) dBc below the mean power output outside a licensee's frequency block (-13dBm).

Method of Measurement: TIA/EIA-603-1992, Section 2.2.12
The antenna substitution method was used to determine the equivalent radiated power at spurious frequencies. The spurious emissions were measured at a distance of 3 meters. The EUT was then replaced with a reference substitution antenna with a known gain referenced to a dipole. This antenna was fed with a signal at the spurious frequency. The level of the signal was adjusted to repeat the previously measured level. The resulting ERP is the signal level fed to the reference antenna corrected for gain referenced to a dipole.

Per FCC Requirements, the antenna substitution method can be replaced by using following calculation to yield the required limit criteria WHEN the max. level of measured spurious emissions is 30dB below the limit.

Calculation for Required Emission Limit Per 2.1053

With the MCPA RF output level set to 135 watts (51.30 dBm), Radiated Emissions between 10 MHz and 10 GHz (Cellular) or 20GHz (PCS) shall be observed. The “Low, Mid, and High” frequencies shall be used for this test.

The Emission Limits and measuring instrumentation settings established in FCC Part 24.238 shall be followed. Emissions shall be less than $43 + 10 \log (P)$ dBc. Per FCC Part 2.1053(a), “Information submitted shall include the relative radiated power of each spurious emission with reference to the rated power output of the transmitter (*amplifier*), assuming all emissions are radiated from half-wave dipole antennas.” The following relationships yield the required limit criteria.

For a half-wave dipole antenna in free space:

$$E = (49.2 * P)^{1/2} / R \quad [\text{V/m}]$$

Where:

E = Field intensity in Volts/meter of carrier

P = transmitted power in Watts (75 W)

R = Distance from antenna to UUT in meters (3 meters)

Conversion of E, Volts/meter to dBuV/m:

$$20 \log (E * 10^6) \quad [\times 10^6]$$

Attenuation requirement (Atten): $43 + 10 \log P$ [dBc]

Thus, the required limit:

$$E_{lim} = E - \text{Atten} \quad \text{dBuV/m}$$

For MCPA:

$$E_{lim} = \mathbf{84.38 \text{ dBuV/m}}$$

Note: Emissions less than 64.38 dBuV/m (84.38 - 20 dB) may not be reported.

Test Result:

Complies

Test Data:

See Attached Table(s)

Configuration	PCS w/ RF Output Port Terminated
Band	PCS Downlink
Channel	Low

Freq. (MHz)	H,V	SA Reading (dBuV)	Height (m)	Angle (degree)	Calculated 3m Limit (dBuV)	Margin (dB)	Absolute Limit (dBm)	Margin (dB)
3862.5	H	58.2	1.4	350	84.38	-26.18	-13	-35.8
5793.75	H	61.9	1.4	340	84.38	-22.48	-13	-32.1
7725.0	H	57.5	1.2	350	84.38	-26.88	-13	-36.5
3862.5	V	57.3	1.3	350	84.38	-27.08	-13	-36.7
5793.75	V	64.0	1.4	340	84.38	-20.38	-13	-30
7725.0	V	57.0	1.1	0	84.38	-27.38	-13	-37

NOTE:

* Measured noise floor

SA: Spectrum Analyzer

EUT's input.: 2CW signals w/ 600K spacing

H=horizontal and V=vertical

SA Reading: Average Reading

Configuration	PCS w/ RF Output Port Terminated
Band	PCS Downlink
Channel	Mid

Freq. (MHz)	H,V	SA Reading (dBuV)	Height (m)	Angle (degree)	Calculated 3m Limit (dBuV)	Margin (dB)	Absolute Limit (dBm)	Margin (dB)
3920	H	62.9	1.4	330	84.38	-21.48	-13	-31.1
5880	H	65.0	1.2	350	84.38	-19.38	-13	-29
7840	H	58.4	1.2	350	84.38	-25.98	-13	-35.6
9800	H	57.0	1.1	350	84.38	-27.38	-13	-37
3920	V	63.9	1.3	350	84.38	-20.48	-13	-30.1
5880	V	68.6	1.2	350	84.38	-15.78	-13	-25.4
7840	V	58.2	1.1	0	84.38	-26.18	-13	-35.8
9800	V	57.7	1.1	350	84.38	-26.68	-13	-36.3

NOTE:

* Measured noise floor

SA: Spectrum Analyzer

H=horizontal and V=vertical

SA Reading: Average Reading

Configuration	PCS w/ RF Output Port Terminated
Band	PCS Downlink
Channel	High

Freq. (MHz)	H,V	SA Reading (dBuV)	Height (m)	Angle (degree)	Calculated 3m Limit (dBuV)	Margin (dB)	Absolute Limit (dBm)	Margin (dB)
3977.5	H	63.9	1.2	350	84.38	-20.48	-13	-30.1
5966.25	H	61.4	1.2	320	84.38	-22.98	-13	-32.6
7955.0	H	55.9	1.2	350	84.38	-28.48	-13	-38.1
3977.5	V	63.6	1.4	0	84.38	-20.78	-13	-30.4
5966.25	V	64.3	1.2	350	84.38	-20.08	-13	-29.7
7955.0	V	56.3	1.1	350	84.38	-28.08	-13	-37.7

NOTE:

* Measured noise floor

SA: Spectrum Analyzer

H=horizontal and V=vertical

SA Reading: Average Reading

Section 7. Frequency Stability

Name of Test:	<i>Frequency Stability</i>	Test Standard:	<i>2.1055 22.355&24.235</i>
Tested By:	WEI LI	Test Date:	06/02-06/14/2005

Minimum Standard: Para. No. 22.355. The transmitter carrier frequency shall remain within the tolerances given in Table C-1.

TABLE C-1.—FREQUENCY TOLERANCE FOR TRANSMITTERS IN THE PUBLIC MOBILE SERVICES

Frequency range (MHz)	Base, fixed (ppm)	Mobile ≤3 watts (ppm)	Mobile ≤3 watts (ppm)
25 to 50	20.0	20.0	50.0
50 to 450	5.0	5.0	50.0
450 to 512	2.5	5.0	5.0
821 to 896	1.5	2.5	2.5
928 to 929	5.0	n/a	n/a
929 to 960	1.5	n/a	n/a
2110 to 2220	10.0	n/a	n/a

Para No. 24.235. The frequency stability shall be sufficient to ensure that the fundamental emission stays within the authorized frequency block.

Method of Measurement: Frequency Stability With Voltage Variation:
The E.U.T. is placed in an environmental chamber and allowed to stabilize at +25 degrees Celsius for at least 15 minutes. Set SA resolution bandwidth low enough (30Hz) to obtain the desired frequency resolution. (Using frequency counter method: The frequency counter and signal generator are phase locked with the same 10 MHz reference frequency by connecting the 10 MHz ref. out of the counter to the 10MHz ref, in of the signal generator). With the voltage input to the E.U.T. set to 85% S.T.V., the frequency is measured in 30 second intervals for a period of 5 minutes. This procedure is repeated at 100% S.T.V. and 115% S.T.V.

Frequency Stability With Temperature Variation:
The input voltage to the E.U.T. is set to S.T.V. and the temperature of the environmental chamber is varied in 10 degree steps from -30 degrees C to +50 degrees C. The E.U.T. is allowed to stabilize at each temperature and the frequency is measured in 30 second intervals for a period of 5 minutes.

Test Result:

Complies

Test Data:

See Attached Table(s)

Not Applicable

Section 8. Test Equipment List

Manufacture	Model	Serial No.	Description	Cal Due dd/mm/ yy
HP	HP8546A	3448A00290	EMI Receiver	15/09/08
HP	E4432B	US38220355	250K-3GHz Signal Generator	15/07/08
EMCO	3104C	9307-4396	20-300MHz Biconical Antenna	15/09/08
EMCO	3146	9008-2860	200-1000MHz Log-Periodic Antenna	09/02/09
Fischer Custom	LIPARTS NO.-2	900-4-0008	Line Impedance Stabilization Networks	15/09/08
Fischer Custom	LIPARTS NO.-2	900-4-0009	Line Impedance Stabilization Networks	23/08/08
EMCO	6502	2665	10KHz-30MHz Active Loop Antenna	27/02/09
EMCO	3115	4945	Double Ridge Guide Horn Antenna	13/09/08
R&S	ESPI	100018	EMI Receiver	16/07/08
HP	8569B	2607A02802	1GHz-22GHz Spectrum Analyzer	10/02/09
Delta Design	5900C	0-67-26	Temperature Chamber	24/03/08
HP	E8254A	US42110367	Signal Generator	23/03/08
Electro-Metrics	RGA-15	8-95	Double Ridge Guide Horn Antenna	10/02/09
EMCO	3116	4943	Double Ridge Guide Horn Antenna	11/01/08
Scientific-Atlanta	12A-18	441	Wave Guide Horn Antenna	04/08/08
HP	4419A	US37292112	RF Power Meter w/ Sensor Probe	20/07/08
Chamber	GD-32-33	LN2	Temperature Chamber	28/07/08
HP	6032A	3323A-09526	System Power Supply	01/07/08
Agilent	E4438C	US41460731	ESG Vector Signal Generator	01/07/08
Agilent	E4438C	US41460771	ESG Vector Signal Generator	01/07/08
Agilent	E4438C	US41460400	ESG Vector Signal Generator	01/07/08
Agilent	E4440A	US40420700	3Hz-26.5GHz Spectrum Analyzer	12/05/08
Lorch Microwave	5NF- 800/1000-S	AC3	Notch Filter	
Lorch Microwave	5NF- 1800/2200-S	AE10	Notch Filter	
RES-NET	RFA500NFF 30	0108	30dB in-line Power Attenuator	
Narda	3022	80986	Directional Coupler	
General Purpose			0-60V, 50A DC Power Supply	

Section 9. FCC ID Labeling

FCC ID: S8L-100978MCPA

This device complies with Part 2, 15 & 24 of the FCC Rules. Operation is subject to the following two conditions:

- (1) this device may not cause harmful interference. and
- (2) this device must accept any interference received, including interference that may cause undesired

FCC ID Label

(The statement may be shown in its User Manual)

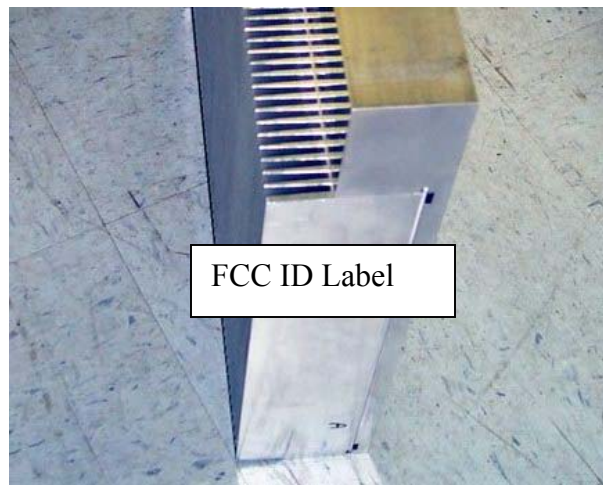

FCC Label Location (back of EUT)

Section 10. Maximum Permissible Exposure

MPE estimate is given per 2.1091 of FCC Rules:

Calculation Equation:

$$d = 0.282 \times \frac{10^{\frac{P+G}{20}}}{\sqrt{S}}$$

Where, P--max. Output Power, G—Antenna Gain and S—Power Density Factor from §1.1310.

Plug all three items into the equation, and yields,

Power Density MPE Limit (mW/ cm ²)	Output Power (dBm)	Server Antenna Gain (dBi)	Donor Antenna Gain (dBi)	Server MPE Distance (cm)	Donor MPE Distance (cm)

NOTE:

For mobile or fixed location transmitters, the minimum separation distance is 20 cm, even if calculations indicate that the MPE distance would be less.

N/A FOR THIS CASE ----AMPLIFIER ONLY, NO ATENNNNA PRESENT.