

**ELECTROMAGNETIC EMISSIONS COMPLIANCE REPORT
INTENTIONAL RADIATOR CERTIFICATION TO
FCC PART 15 SUBPART C AND CANADIAN RSS 210 ISSUE 8
REQUIREMENTS**

OF

nextbook

MODEL No.: NXW10QC32G

FCC ID: S7JNXW10QC32G

IC: 8082A-NXW10QC32G

Trade Mark: N/A

REPORT NO: ES140828400E1

ISSUE DATE: September 09, 2014

Prepared for
SHENZHEN YIFANG DIGITAL TECHNOLOGY CO., LTD.
Building NO.22,23, Fifth Region, Baiwangxin Industrial Park, Songbai Rd.,
Nanshan, Shenzhen 518108, China

Prepared by
SHENZHEN EMTEK CO., LTD

Bldg 69, Majialong Industry Zone, Nanshan District,
Shenzhen, Guangdong, China
TEL: 86-755-26954280
FAX: 86-755-26954282

VERIFICATION OF COMPLIANCE

Applicant:	SHENZHEN YIFANG DIGITAL TECHNOLOGY CO., LTD. Building NO.22,23, Fifth Region, Baiwangxin Industrial Park, Songbai Rd., Nanshan, Shenzhen 518108, China
Manufacturer:	SHENZHEN YIFANG DIGITAL TECHNOLOGY CO., LTD. Building NO.22,23, Fifth Region, Baiwangxin Industrial Park, Songbai Rd., Nanshan, Shenzhen 518108, China
Product Description:	nextbook
Model Number:	NXW10QC32G
File Number:	ES140828400E1
Date of Test:	August 29, 2014 to September 09, 2014

We hereby certify that:

The above equipment was tested by SHENZHEN EMTEK CO., LTD. The test data, data evaluation, test procedures, and equipment configurations shown in this report were made in accordance with the procedures given in ANSI C63.4 (2009) and the energy emitted by the sample EUT tested as described in this report is in compliance with conducted and radiated emission limits of FCC Rules Part 15.247 and Canadian RSS 210 ISSUE 8 REQUIREMENTS

The test results of this report relate only to the tested sample identified in this report.

Date of Test : August 29, 2014 to September 09, 2014

Prepared by : 
Yaping Shen/Editor

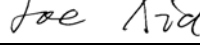
Reviewer : 
Joe Xia/Supervisor

Approve & Authorized Signer : 
Lisa Wang/Manager

Table of Contents

1. GENERAL INFORMATION	5
1.1 PRODUCT DESCRIPTION	5
1.2 RELATED SUBMITTAL(S) / GRANT(S)	5
1.3 TEST METHODOLOGY	6
1.4 SPECIAL ACCESSORIES	6
1.5 EQUIPMENT MODIFICATIONS	6
1.6 TEST FACILITY	6
2. SYSTEM TEST CONFIGURATION	7
2.1 EUT CONFIGURATION	7
2.2 EUT EXERCISE	7
2.3 TEST PROCEDURE	7
2.4 CONFIGURATION OF TESTED SYSTEM	7
3. DESCRIPTION OF TEST MODES	9
4. SUMMARY OF TEST RESULTS	10
5. CONDUCTED EMISSIONS TEST	11
5.1 MEASUREMENT PROCEDURE	11
5.2 TEST SET-UP (BLOCK DIAGRAM OF CONFIGURATION)	11
5.3 MEASUREMENT EQUIPMENT USED	11
5.4 CONDUCTED EMISSION LIMIT	11
5.5 MEASUREMENT RESULT	12
6. RADIATED EMISSION TEST	16
6.1 MEASUREMENT PROCEDURE	16
6.2 TEST SET-UP (BLOCK DIAGRAM OF CONFIGURATION)	17
6.3 MEASUREMENT EQUIPMENT USED	18
6.4 RADIATED EMISSION LIMIT	18
6.5 MEASUREMENT RESULT	20
7. 6DB BANDWIDTH TEST AND 99% BANDWIDTH TEST	30
7.1 MEASUREMENT PROCEDURE	30
7.2 TEST SET-UP (BLOCK DIAGRAM OF CONFIGURATION)	30
7.3 MEASUREMENT EQUIPMENT USED	30
7.4 MEASUREMENT RESULTS	30
8. MAXIMUM PEAK OUTPUT POWER TEST	47
8.1 MEASUREMENT PROCEDURE	47
8.2 TEST SET-UP (BLOCK DIAGRAM OF CONFIGURATION)	47
8.3 MEASUREMENT EQUIPMENT USED	47
8.4 PEAK POWER OUTPUT LIMIT	47
8.5 MEASUREMENT RESULTS	47
9. BAND EDGE TEST	49
9.1 MEASUREMENT PROCEDURE	49
9.2 TEST SET-UP (BLOCK DIAGRAM OF CONFIGURATION)	49
9.3 MEASUREMENT EQUIPMENT USED	49
9.4 MEASUREMENT RESULTS	50
10. POWER DENSITY	52
10.1 TEST EQUIPMENT	52
10.2 MEASURING INSTRUMENTS AND SETTING	52
10.3 TEST PROCEDURES	52
10.4 BLOCK DIAGRAM OF TEST SETUP	52

10.5	LIMIT	52
10.6	TEST RESULT	53
11.	ANTENNA PORT EMISSION	61
11.1	TEST EQUIPMENT	61
11.2	MEASURING INSTRUMENTS AND SETTING	61
11.3	TEST PROCEDURES	61
11.4	BLOCK DIAGRAM OF TEST SETUP	61
11.5	TEST RESULT	61
12.	ANTENNA APPLICATION	65
12.1	ANTENNA REQUIREMENT	65
12.2	RESULT	65

1. General Information

1.1 Product Description

A major technical descriptions of EUT is described as following:

- A). Standards: IEEE802.11b/g/n
- B). Operation Frequency: Bluetooth: 2402-2480MHz,
 WIFI 802.11b/g/n HT20: 2412-2462MHz;
 WIFI 802.11n HT40: 2422-2452MHz
- C). Modulation: Bluetooth: GFSK
 WIFI: OFDM with BPSK/QPSK/16QAM/64QAM for 802.11g/n,
 DSSS with DBPSK/DQPSK/CCK for 802.11b
- D). Number of Channel: 802.11b/g/ n HT20: 11Channels;
 802.11n HT40: 7 Channels;
 BT: 40 Channels;
- E).Conducted Power: 9.83dBm(802.11b) for Max
- F) Antenna Gain: 2dBi
- G). Antenna Type: Integral Antenna
- H). Power Supply: DC 5V with AC Adapter and DC 3.7V from Li-ion Battery.
- I). Adapter 1: Model: PS18C050K2500UD
 Input: 100-240V~50/60Hz 0.5A
 Output: DC 5V 2500mA
- J). Adapter 2: Model: TEKA018-0502500UK
 Input: 100-240V~50/60Hz 0.5A MAX
 Output: DC 5V 2.5A

Channel	Frequency (MHz)	Channel	Frequency (MHz)	Channel	Frequency (MHz)
1	2412	5	2432	9	2452
2	2417	6	2437	10	2457
3	2422	7	2442	11	2462
4	2427	8	2447		

Note:

1. This device is included 802.11b, 802.11g, 802.11n 2.4GHz transceiver function.
2. Test of channel was included the lowest middle and highest frequency in lowest data rate and to perform the test, then record on this report.

1.2 Related Submittal(s) / Grant(s)

This submittal(s) (test report) is intended for FCC ID: S7JNXW10QC32G filing to comply with Section 15.247 of the FCC Part 15, Subpart C Rules and also intended for IC: 8082A-NXW10QC32G filing to comply with Canadian RSS 210 Issue 8.0. The composite system is compliance with Subpart B is authorized under a DOC procedure.

1.3 Test Methodology

All the test program has follow FCC new test procedure KDB558074 D01 v03r02, Both conducted and radiated testing was performed according to the procedures in ANSI C63.10 (2009). Radiated testing was performed at an antenna to EUT distance 3 meters.

1.4 Special Accessories

Not available for this EUT intended for grant.

1.5 Equipment Modifications

Not available for this EUT intended for grant.

1.6 Test Facility

Site Description

EMC Lab.

: Accredited by CNAS, 2013.10.29
The certificate is valid until 2016.10.28
The Laboratory has been assessed and proved to be in compliance with CNAS/CL01: 2006(identical to ISO/IEC17025: 2005)
The Certificate Registration Number is L2291

Accredited by TUV Rheinland Shenzhen 2010.5.25
The Laboratory has been assessed according to the requirements ISO/IEC 17025

Accredited by FCC, April 17, 2013
The Certificate Registration Number is 406365.

Accredited by Industry Canada, March 05, 2010
The Certificate Registration Number is 46405-4480.

Name of Firm

: SHENZHEN EMTEK CO., LTD.

Site Location

: Bldg 69, Majialong Industry Zone,
Nanshan District, Shenzhen, Guangdong, China

2. System Test Configuration

2.1 EUT Configuration

The EUT configuration for testing is installed on RF field strength measurement to meet the Commissions requirement and operating in a manner which intends to maximize its emission characteristics in a continuous normal application.

2.2 EUT Exercise

The Transmitter was operated in the normal operating mode. The TX frequency was fixed which was for the purpose of the measurements.

2.3 Test Procedure

2.3.1 Conducted Emissions

The EUT is placed on a turn table which is 0.8 m above ground plane. According to the requirements in Section 13.1.4.1 of ANSI C63.4-2009 Conducted emissions from the EUT measured in the frequency range between 0.15 MHz and 30 MHz using CISPR Quasi-Peak and average detector mode.

2.3.2 Radiated Emissions

The EUT is placed on a turn table which is 0.8 m above ground plane. The turn table shall rotate 360 degrees to determine the position of maximum emission level. EUT is set 3m away from the receiving antenna which varied from 1m to 4m to find out the highest emission. And also, each emission was to be maximized by changing the polarization of receiving antenna both horizontal and vertical. In order to find out the max. Emission, the relative positions of this hand-held transmitter (EUT) was rotated through three orthogonal axes according to the requirements in Section 13.1.4.1 of ANSI C63.4-2009.

2.4 Configuration of Tested System

Fig. 2-1 Configuration of Tested System

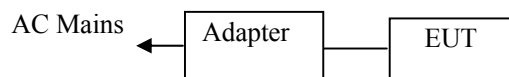

Table 2-1 Equipment Used in Tested System

Item	Equipment	Mfr/Brand	Model/Type No.	FCC ID	IC ID	Series No.	Note
1.	nextbook	N/A	NXW10QC32G	S7JNXW10QC 32G	8082A-NXW10QC 32G	N/A	EUT

Note:

- (1) Unless otherwise denoted as EUT in 『Remark』 column, device(s) used in tested system is a support equipment.

3. Description of Test Modes

The Transmitter of EUT is an Mobile Internet Device and powered by host equipment; these is Digital Transmission system (DTS) and have modulation OFDM, DSSS, DBPSK, DQPSK, CCK, 16QAM, 64QAM. According exploratory test, EUT will have maximum output power in those data rate (802.11b: 1 Mbps; 802.11g: 6 Mbps; 802.11n: MCS0), so those data rate were used for all test.

The equipment enables high-speed access without wires to network assets. This adapter uses the IEEE 802.11 protocol to enable wireless communications between the host and Wireless router.

For 802.11b/g/n HT20:

1. For lowest channel : 2412MHz (Channel 1)
2. For middle channel : 2437MHz (Channel 6)
3. For highest channel : 2462MHz (Channel 11)

For 802.11b/g/n HT40:

4. For lowest channel : 2422MHz (Channel 3)
5. For middle channel : 2437MHz (Channel 6)
6. For highest channel : 2452MHz (Channel 9)

4. Summary of Test Results

FCC Rules	IC Rule	Description Of Test	Result
§15.247(a)(2)	RSS-210, A8.2(a)	6dB bandwidth	Pass
§15.247(b)(3)	RSS-210, A8.4(2)	Max Peak output Power test	Pass
§15.247(e)	RSS-210, A8.2(b)	Power density	Pass
§15.247(d)	RSS-210, A2.9, A8.5	Band edge test	Pass
§15.207	RSS-GEN, Section 7.2.2	AC Power Conducted Emission	Pass
§15.247(d), §15.209	RSS-210, A2.9, A8.5	Radiated Emission	Pass
§15.247(d)	RSS-210, A8.5 RSS-GEN, Section 7.2.3	Antenna Port Emission	Pass
§15.247(b)&§15.203	N/A	Antenna Application	Pass
N/A	RSS-210, A1.1.3	99%dB Bandwidth	Pass

5. Conducted Emissions Test

5.1 Measurement Procedure

1. The EUT was placed on a table which is 0.8m above ground plane.
2. Maximum procedure was performed on the six highest emissions to ensure EUT compliance.
3. Repeat above procedures until all frequency measured were complete.

5.2 Test SET-UP (Block Diagram of Configuration)

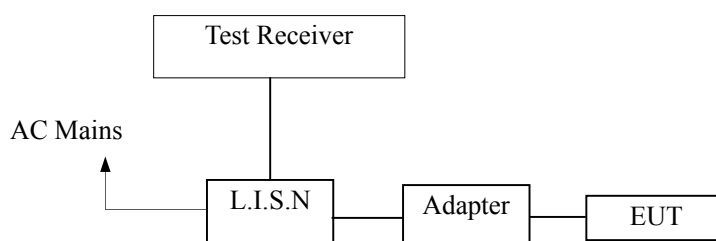

5.3 Measurement Equipment Used

Conducted Emission Test Site					
EQUIPMENT TYPE	MFR	MODEL NUMBER	SERIAL NUMBER	LAST CAL.	CAL DUE.
Test Receiver	Rohde & Schwarz	ESCS30	828985/018	05/17/2014	05/16/2015
L.I.S.N.	Schwarzbeck	NNLK8129	8129203	05/17/2014	05/16/2015
50Ω Coaxial Switch	Anritsu	MP59B	M20531	N/A	N/A
Pulse Limiter	Rohde & Schwarz	ESH3-Z2	100006	05/17/2014	05/16/2015
Voltage Probe	Rohde & Schwarz	TK9416	N/A	05/17/2014	05/16/2015
I.S.N	Rohde & Schwarz	ENY22	1109.9508.02	05/17/2014	05/16/2015

5.4 Conducted Emission Limit

Conducted Emission

Frequency(MHz)	Quasi-peak	Average
0.15-0.5	66-56	56-46
0.5-5.0	56	46
5.0-30.0	60	50

- Note:** 1. The lower limit shall apply at the transition frequencies
 2. The limit decreases in line with the logarithm of the frequency in the range of 0.15 to 0.50MHz.

5.5 Measurement Result

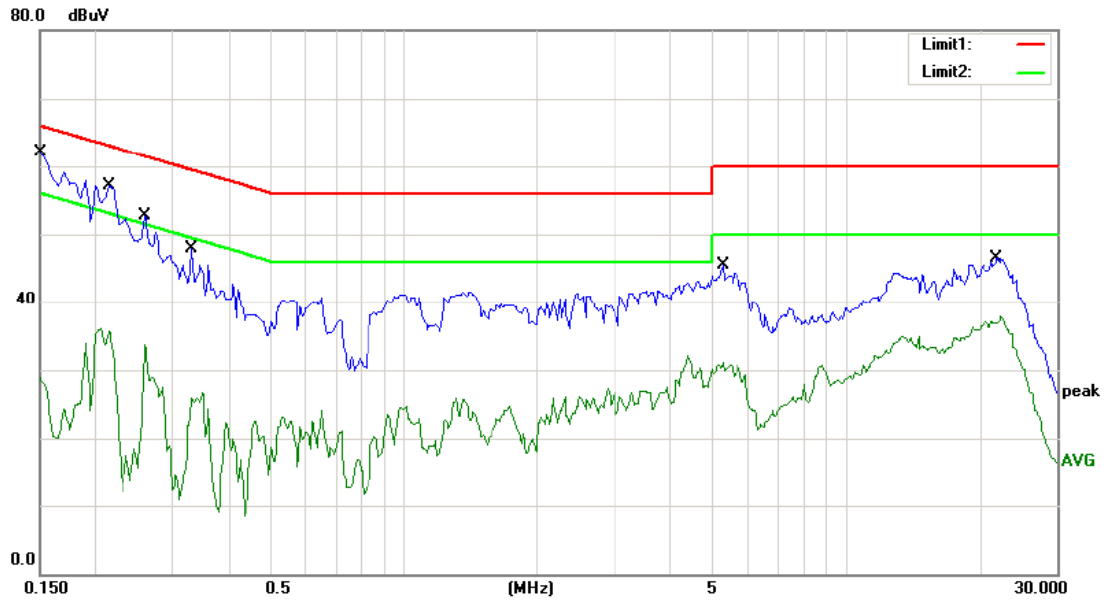

Site Conduction #1 Phase: **L1** Temperature: 26
 Limit: (CE)FCC PART 15 C Power: AC 120V/60Hz Humidity: 60 %
 Mode: WIFI ON
 Note: Adapter 1

No.	Mk.	Freq. MHz	Reading Level dBuV	Correct Factor dB	Measure- ment dBuV	Limit dBuV	Over dB	Detector	Comment
1	*	0.1500	61.34	0.00	61.34	66.00	-4.66	QP	
2		0.1500	28.46	0.00	28.46	56.00	-27.54	AVG	
3		0.2162	56.89	0.00	56.89	62.96	-6.07	QP	
4		0.2162	36.13	0.00	36.13	52.96	-16.83	AVG	
5		0.2600	52.67	0.00	52.67	61.43	-8.76	QP	
6		0.2600	33.70	0.00	33.70	51.43	-17.73	AVG	
7		0.3300	47.82	0.00	47.82	59.45	-11.63	QP	
8		0.3300	26.77	0.00	26.77	49.45	-22.68	AVG	
9		5.2500	45.46	0.00	45.46	60.00	-14.54	QP	
10		5.2500	31.01	0.00	31.01	50.00	-18.99	AVG	
11		22.0500	46.44	0.00	46.44	60.00	-13.56	QP	
12		22.0500	37.92	0.00	37.92	50.00	-12.08	AVG	

*:Maximum data x:Over limit !:over margin Comment: Factor build in receiver. Operator: Cai

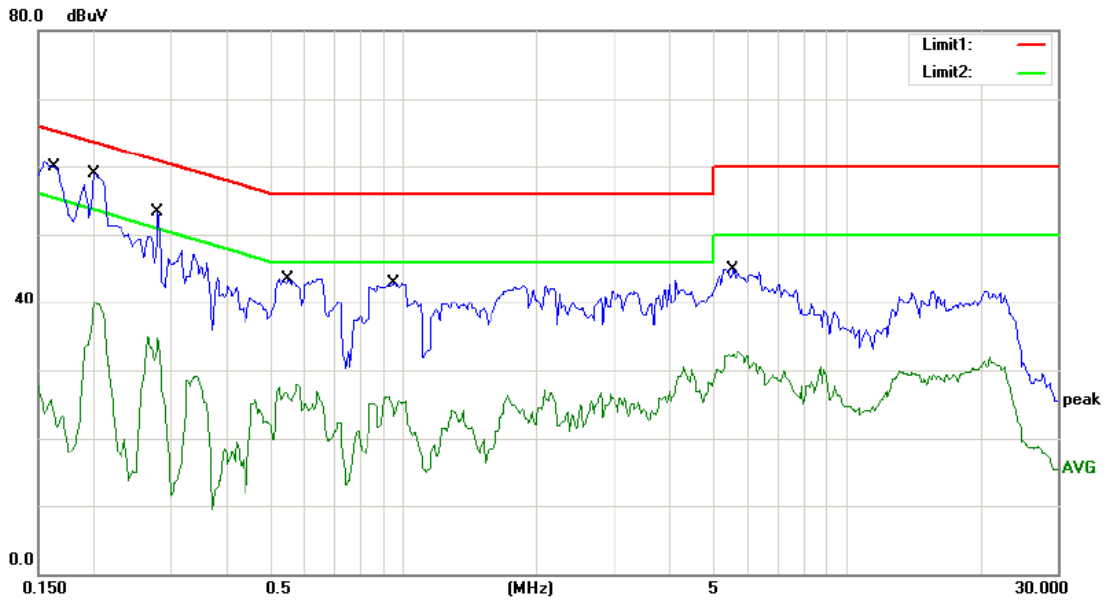

Site Conduction #1
 Limit: (CE)FCC PART 15 C
 Mode: WIFI ON
 Note: Adapter 1

Phase: **N**
 Power: AC 120V/60Hz

Temperature: 26
 Humidity: 60 %

No.	Mk.	Freq. MHz	Reading Level dBuV	Correct Factor dB	Measure- ment dBuV	Limit dBuV	Over dB	Detector	Comment
1		0.1641	60.18	0.00	60.18	65.25	-5.07	QP	
2		0.1641	28.04	0.00	28.04	55.25	-27.21	AVG	
3	*	0.2000	58.94	0.00	58.94	63.61	-4.67	QP	
4		0.2000	39.89	0.00	39.89	53.61	-13.72	AVG	
5		0.2800	53.21	0.00	53.21	60.82	-7.61	QP	
6		0.2800	34.91	0.00	34.91	50.82	-15.91	AVG	
7		0.5500	43.56	0.00	43.56	56.00	-12.44	QP	
8		0.5500	27.58	0.00	27.58	46.00	-18.42	AVG	
9		0.9550	42.87	0.00	42.87	56.00	-13.13	QP	
10		0.9550	26.19	0.00	26.19	46.00	-19.81	AVG	
11		5.5600	44.96	0.00	44.96	60.00	-15.04	QP	
12		5.5600	32.76	0.00	32.76	50.00	-17.24	AVG	

*:Maximum data x:Over limit !:over margin Comment: Factor build in receiver. Operator: Cai

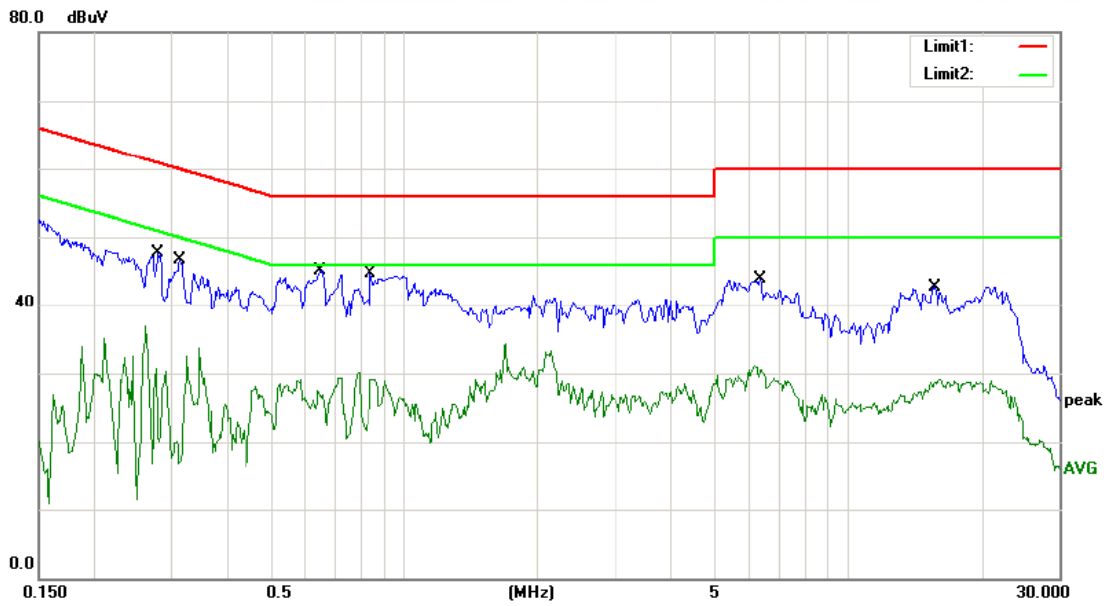

Site Conduction #1 Phase: **L1** Temperature: 26
 Limit: (CE)FCC PART 15 C Power: AC 120V/60Hz Humidity: 60 %
 Mode: WIFI ON
 Note: Adapter 2

No.	Mk.	Freq. MHz	Reading Level dBuV	Correct Factor dB	Measure- ment dBuV	Limit dBuV	Over dB	Detector	Comment
1		0.2800	47.71	0.00	47.71	60.82	-13.11	QP	
2		0.2800	20.99	0.00	20.99	50.82	-29.83	AVG	
3		0.3113	46.73	0.00	46.73	59.94	-13.21	QP	
4		0.3113	25.50	0.00	25.50	49.94	-24.44	AVG	
5	*	0.6450	45.03	0.00	45.03	56.00	-10.97	QP	
6		0.6450	25.73	0.00	25.73	46.00	-20.27	AVG	
7		0.8400	44.71	0.00	44.71	56.00	-11.29	QP	
8		0.8400	28.67	0.00	28.67	46.00	-17.33	AVG	
9		6.3700	43.92	0.00	43.92	60.00	-16.08	QP	
10		6.3700	30.50	0.00	30.50	50.00	-19.50	AVG	
11		15.7500	42.80	0.00	42.80	60.00	-17.20	QP	
12		15.7500	28.71	0.00	28.71	50.00	-21.29	AVG	

*:Maximum data x:Over limit !:over margin Comment: Factor build in receiver. Operator: Cai

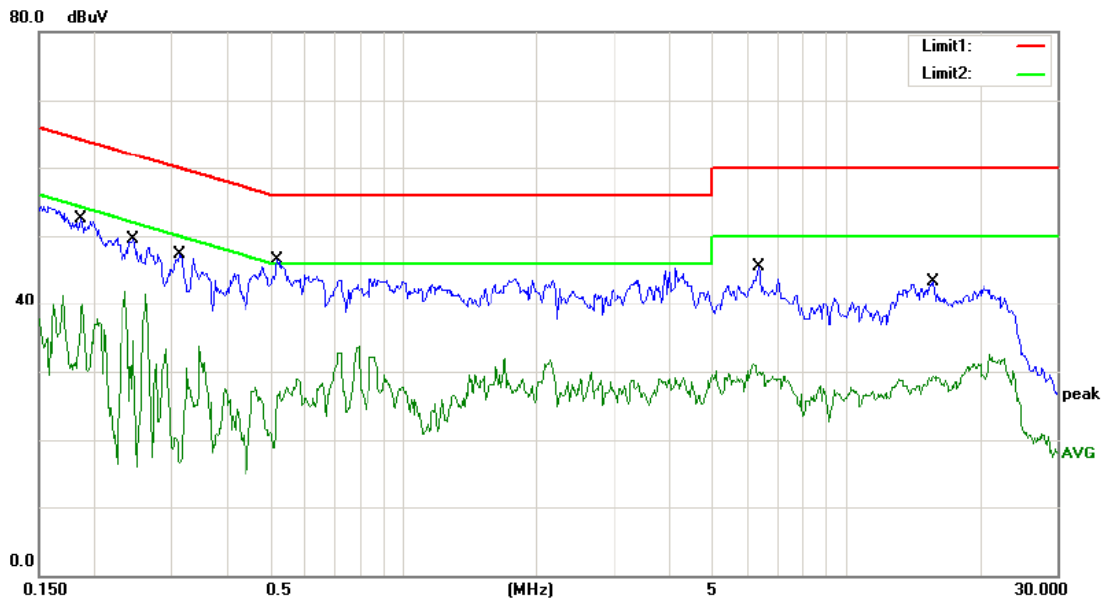

Site Conduction #1 Phase: **N** Temperature: 26
 Limit: (CE)FCC PART 15 C Power: AC 120V/60Hz Humidity: 60 %
 Mode: WIFI ON
 Note: Adapter 2

No.	Mk.	Freq.	Reading Level	Correct Factor	Measurement	Limit	Over	Detector	Comment
		MHz	dBuV	dB	dBuV	dBuV	dB		
1		0.1853	52.55	0.00	52.55	64.24	-11.69	QP	
2		0.1853	39.85	0.00	39.85	54.24	-14.39	AVG	
3		0.2450	49.48	0.00	49.48	61.92	-12.44	QP	
4		0.2450	34.52	0.00	34.52	51.92	-17.40	AVG	
5		0.3113	47.23	0.00	47.23	59.94	-12.71	QP	
6		0.3113	30.52	0.00	30.52	49.94	-19.42	AVG	
7	*	0.5200	46.41	0.00	46.41	56.00	-9.59	QP	
8		0.5200	27.08	0.00	27.08	46.00	-18.92	AVG	
9		6.3700	45.42	0.00	45.42	60.00	-14.58	QP	
10		6.3700	30.00	0.00	30.00	50.00	-20.00	AVG	
11		15.7500	43.30	0.00	43.30	60.00	-16.70	QP	
12		15.7500	29.37	0.00	29.37	50.00	-20.63	AVG	

*:Maximum data x:Over limit !:over margin Comment: Factor build in receiver. Operator: Cai

6. Radiated Emission Test

6.1 Measurement Procedure

1. The EUT was placed on a turn table which is 0.8m above ground plane.
2. Maximum procedure was performed on the six highest emissions to ensure EUT compliance.
3. And also, each emission was to be maximized by changing the polarization of receiving antenna both horizontal and vertical.
4. Repeat above procedures until all frequency measured was complete.

When spectrum scanned from 30 MHz to 1GHz setting resolution bandwidth 120 kHz and video bandwidth 300kHz.

EMI Test Receiver	Setting
Attenuation	Auto
RB	120kHz
VB	300kHz
Detector	QP
Trace	Max hold

When spectrum scanned above 1GHz setting resolution bandwidth 1MHz, video bandwidth 3MHz.

EMI Test Receiver	Setting
Attenuation	Auto
RB	1MHz
VB	3MHz
Detector	Peak
Trace	Max hold

When spectrum scanned above 1GHz setting resolution bandwidth 1MHz, video bandwidth 10Hz.

EMI Test Receiver	Setting
Attenuation	Auto
RB	1MHz
VB	10Hz
Detector	AVG
Trace	Max hold

6.2 Test SET-UP (Block Diagram of Configuration)

(A) Radiated Emission Test Set-Up, Frequency Below 30MHz

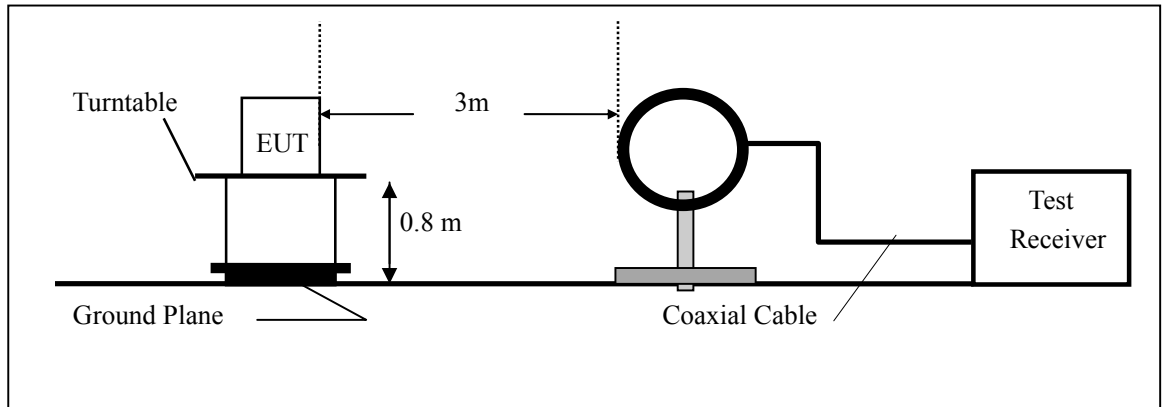

(B) Radiated Emission Test Set-Up, Frequency Below 1000MHz

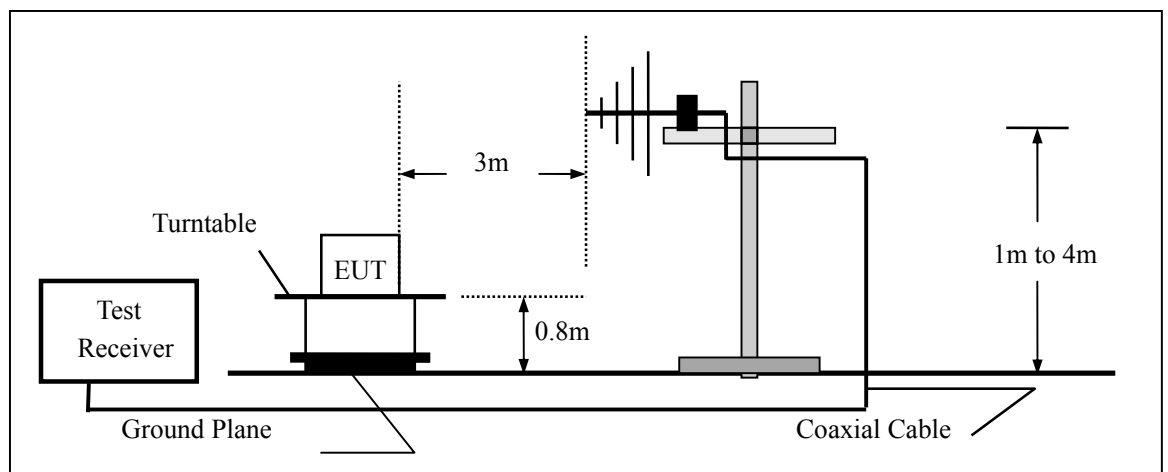

(C) Radiated Emission Test Set-Up, Frequency above 1000MHz

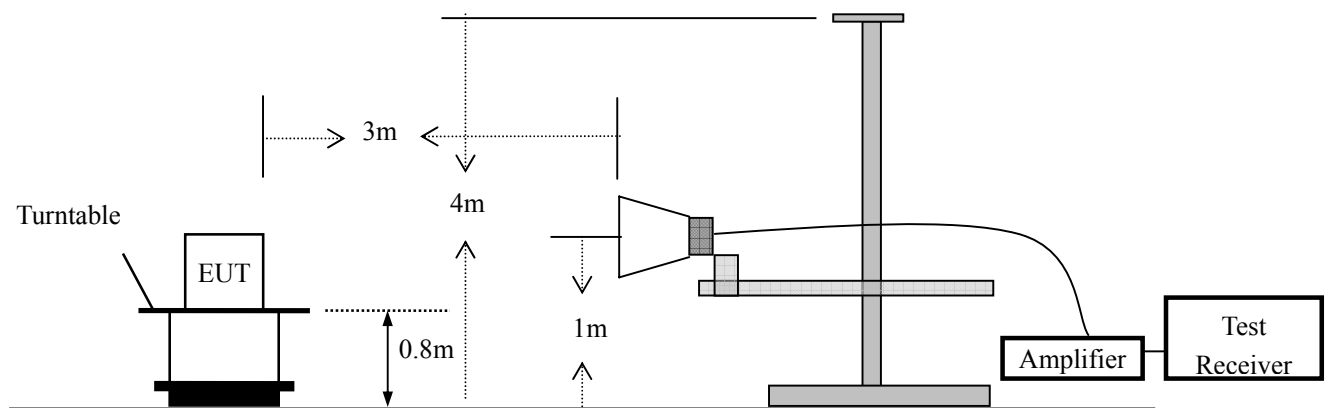

6.3 Measurement Equipment Used

EQUIPMENT TYPE	MFR	MODEL NUMBER	SERIAL NUMBER	LAST CAL.	CAL DUE.
EMI Test Receiver	Rohde & Schwarz	ESU	1302.6005.26	05/17/2014	05/16/2015
Pre-Amplifier	HP	8447D	2944A07999	05/17/2014	05/16/2015
Bilog Antenna	Schwarzbeck	VULB9163	142	05/17/2014	05/16/2015
Loop Antenna	ARA	PLA-1030/B	1029	05/17/2014	05/16/2015
Horn Antenna	Schwarzbeck	BBHA 9170	BBHA9170399	05/17/2014	05/16/2015
Horn Antenna	Schwarzbeck	BBHA 9120	D143	05/17/2014	05/16/2015
Cable	Schwarzbeck	AK9513	ACRX1	05/17/2014	05/16/2015
Cable	Rosenberger	N/A	FP2RX2	05/17/2014	05/16/2015
Cable	Schwarzbeck	AK9513	CRPX1	05/17/2014	05/16/2015
Cable	Schwarzbeck	AK9513	CRRX2	05/17/2014	05/16/2015

6.4 Radiated Emission Limit

The emissions from an intentional radiator shall not exceed the field strength levels specified in the following table 15.209(a):

Frequencies (MHz)	Field Strength (micorvolts/meter)	Measurement Distance (meters)
0.009~0.490	2400/F(KHz)	300
0.490~1.705	24000/F(KHz)	30
1.705~30.0	30	30
30~88	100	3
88~216	150	3
216~960	200	3
Above 960	500	3

15.205 Restricted bands of operation

MHz	MHz	MHz	GHz
0.090 - 0.110	16.42 - 16.423	399.9 - 410	4.5 - 5.15
¹ 0.495 - 0.505	16.69475 - 16.69525	608 - 614	5.35 - 5.46
2.1735 - 2.1905	16.80425 - 16.80475	960 - 1240	7.25 - 7.75
4.125 - 4.128	25.5 - 25.67	1300 - 1427	8.025 - 8.5
4.17725 - 4.17775	37.5 - 38.25	1435 - 1626.5	9.0 - 9.2
4.20725 - 4.20775	73 - 74.6	1645.5 - 1646.5	9.3 - 9.5
6.215 - 6.218	74.8 - 75.2	1660 - 1710	10.6 - 12.7
6.26775 - 6.26825	108 - 121.94	1718.8 - 1722.2	13.25 - 13.4
6.31175 - 6.31225	123 - 138	2200 - 2300	14.47 - 14.5
8.291 - 8.294	149.9 - 150.05	2310 - 2390	15.35 - 16.2
8.362 - 8.366	156.52475 - 156.52525	2483.5 - 2500	17.7 - 21.4
8.37625 - 8.38675	156.7 - 156.9	2690 - 2900	22.01 - 23.12
8.41425 - 8.41475	162.0125 - 167.17	3260 - 3267	23.6 - 24.0
12.29 - 12.293	167.72 - 173.2	3332 - 3339	31.2 - 31.8
12.51975 - 12.52025	240 - 285	3345.8 - 3358	36.43 - 36.5
12.57675 - 12.57725	322 - 335.4	3600 - 4400	(²)

- Remark: 1. Emission level in dBuV/m=20 log (uV/m)
 2. Measurement was performed at an antenna to the closed point of EUT distance of meters.
 3. Only spurious frequency is permitted to locate within the Restricted Bands specified in provision of § 15.205, and the emissions located in restricted bands also comply with 15.209 limit.

6.5 Measurement Result

All the modulation modes were tested the data of the worst mode (TX 11b) are recorded in the following pages and the others modulation methods do not exceed the limits.

Operation Mode: TX Mode Test Date : September 09, 2014
 Frequency Range: 9KHz~30MHz Temperature : 28°C
 Test Result: PASS Humidity : 55 %
 Measured Distance: 3m Test By: SYP

Note:

Freq. (MHz)	Ant.Pol. H/V	Emission Level (dBuV/m)	Limit 3m (dBuV/m)	Over (dB)
--	--	--	--	--

Note: the amplitude of spurious emission that is attenuated by more than 20dB below the permissible limit has no need to be reported.

Distance extrapolation factor = $40 \log(\text{Specific distance} / \text{test distance})$ (dB);

Limit line = Specific limits (dBuV) + distance extrapolation factor.

Operation Mode: 802.11b TX Channel 1 Test Date : September 09, 2014
 Frequency Range: 30~1000MHz Temperature : 28°C
 Test Result: PASS Humidity : 55 %
 Measured Distance: 3m Test By: SYP
 Note:

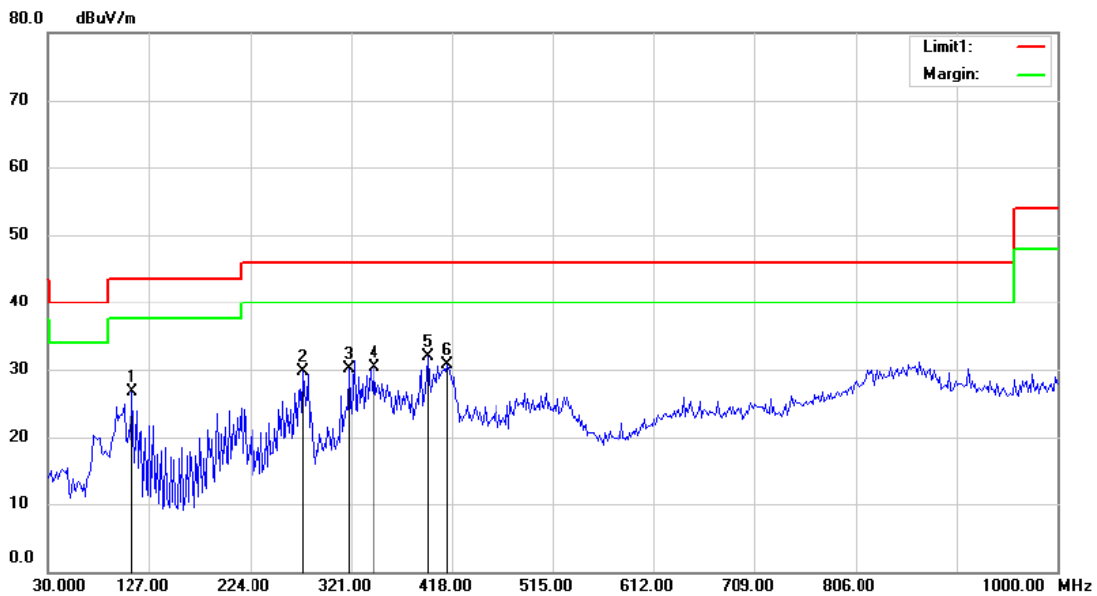

Site site #1 Polarization: **Horizontal** Temperature: 24 C
 Limit: (RE)FCC PART 15 C Power: AC 120V/60Hz Humidity: 53 %
 Mode: TX 2412
 Note:

No.	Mk.	Freq. MHz	Reading Level dBuV	Correct Factor dB	Measure- ment dBuV/m	Limit dBuV/m	Over dB	Antenna Height cm	Table Degree degree	Comment
1		110.8333	14.17	12.53	26.70	43.50	-16.80	QP		
2		275.6090	14.58	15.14	29.72	46.00	-16.28	QP		
3		319.1346	15.61	14.47	30.08	46.00	-15.92	QP		
4		344.0064	14.32	15.89	30.21	46.00	-15.79	QP		
5	*	395.3045	13.34	18.52	31.86	46.00	-14.14	QP		
6		413.9583	11.90	18.80	30.70	46.00	-15.30	QP		

*:Maximum data x:Over limit !:over margin

Operator: ZHL

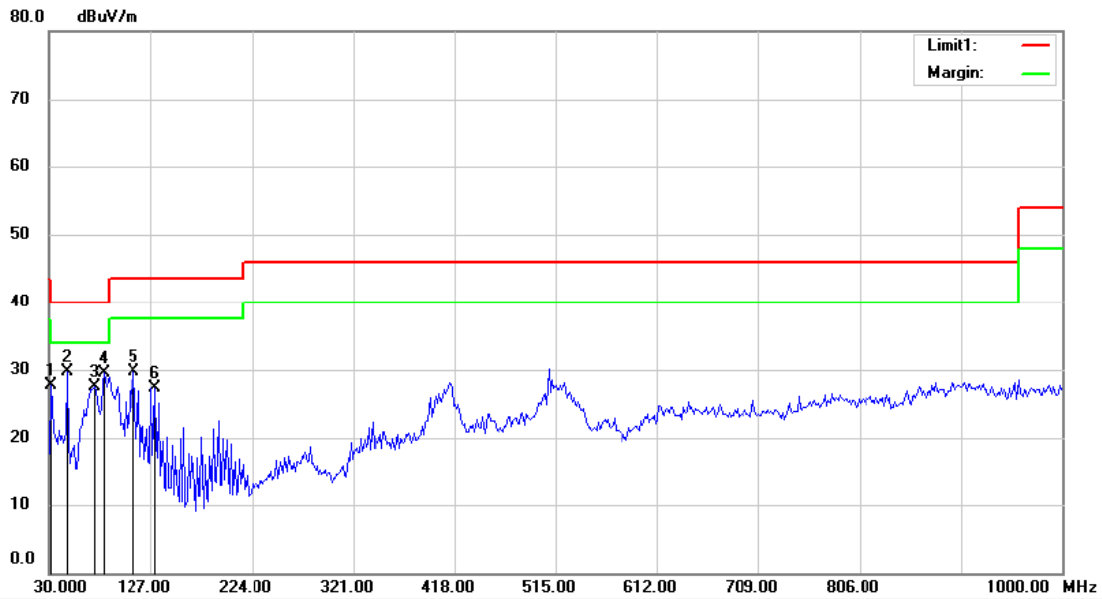

Site site #1 Polarization: **Vertical** Temperature: 24 C
 Limit: (RE)FCC PART 15 C Power: AC 120V/60Hz Humidity: 53 %
 Mode:TX 2412
 Note:

No.	Mk.	Freq.	Reading Level	Correct Factor	Measurement	Limit	Over	Antenna Height	Table Degree	
		MHz	dBuV	dB	dBuV/m	dBuV/m	dB	cm	degree	Comment
1		31.5545	15.30	12.46	27.76	40.00	-12.24	QP		
2	*	47.0994	14.48	15.15	29.63	40.00	-10.37	QP		
3		73.5256	20.02	7.47	27.49	40.00	-12.51	QP		
4		82.8525	21.40	8.04	29.44	40.00	-10.56	QP		
5		110.8333	17.21	12.53	29.74	43.50	-13.76	QP		
6		131.0417	17.59	9.72	27.31	43.50	-16.19	QP		

*:Maximum data x:Over limit !:over margin

Operator: ZHL

Operation Mode: 802.11b TX Channel 6 Test Date : September 09, 2014
 Frequency Range: 30~1000MHz Temperature : 28°C
 Test Result: PASS Humidity : 55 %
 Measured Distance: 3m Test By: SYP
 Note:

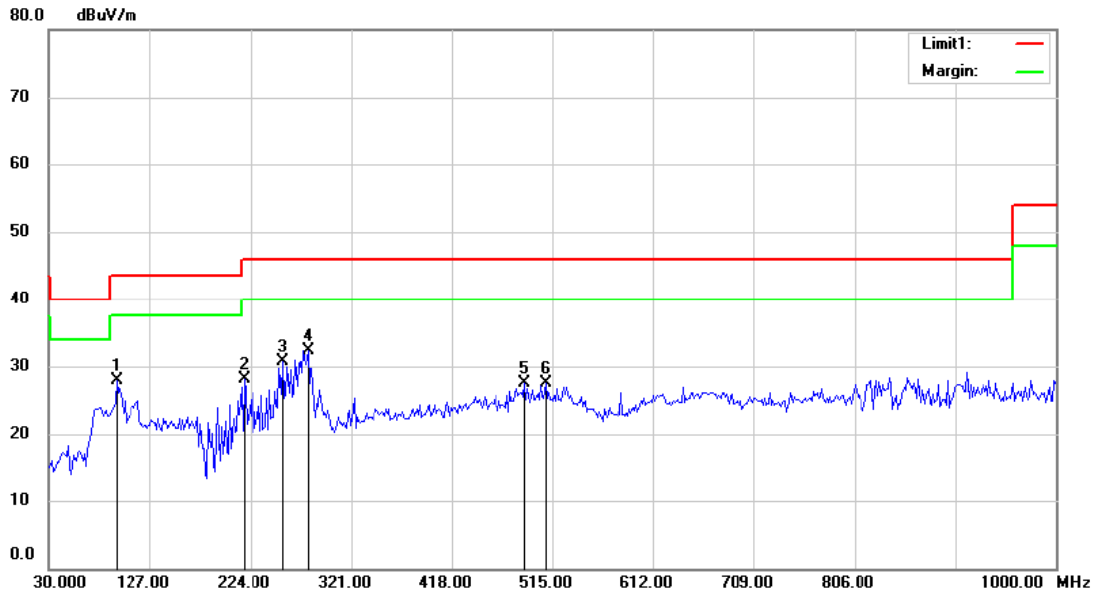

Site site #1 Polarization: **Horizontal** Temperature: 24 C
 Limit: (RE)FCC PART 15 C Power: AC 120V/60Hz Humidity: 53 %
 Mode:TX 2437
 Note:

No.	Mk.	Freq. MHz	Reading Level dBuV	Correct Factor dB	Measure- ment dBuV/m	Limit dBuV/m	Over dB	Antenna Height cm	Table Degree degree	Comment
1		95.2883	15.88	12.10	27.98	43.50	-15.52	QP		
2		218.0930	17.17	10.90	28.07	46.00	-17.93	QP		
3		255.4004	16.65	14.08	30.73	46.00	-15.27	QP		
4	*	280.2724	17.35	14.97	32.32	46.00	-13.68	QP		
5		488.5735	8.03	19.42	27.45	46.00	-18.55	QP		
6		508.7820	6.48	20.99	27.47	46.00	-18.53	QP		

*:Maximum data x:Over limit !:over margin

Operator: ZHL



Site site #1 Polarization: **Vertical** Temperature: 24 C
 Limit: (RE)FCC PART 15 C Power: AC 120V/60Hz Humidity: 53 %
 Mode: TX 2437
 Note:

No.	Mk.	Freq.	Reading	Correct	Measure-	Limit	Over	Antenna	Table	
		MHz	Level	Factor	ment			Height	Degree	Comment
			dBuV	dB	dBuV/m	dBuV/m	dB	cm	degree	
1		89.0704	15.09	9.99	25.08	43.50	-18.42	QP		
2		135.7050	17.66	9.52	27.18	43.50	-16.32	QP		
3		191.6665	15.77	10.29	26.06	43.50	-17.44	QP		
4		413.9583	12.29	18.80	31.09	46.00	-14.91	QP		
5	*	508.7820	10.12	20.99	31.11	46.00	-14.89	QP		
6		614.4871	4.71	21.90	26.61	46.00	-19.39	QP		

*:Maximum data x:Over limit l:over margin

Operator: ZHL

Operation Mode: 802.11b TX Channel 11 Test Date : September 09, 2014
 Frequency Range: 30~1000MHz Temperature : 28°C
 Test Result: PASS Humidity : 55 %
 Measured Distance: 3m Test By: SYP
 Note:

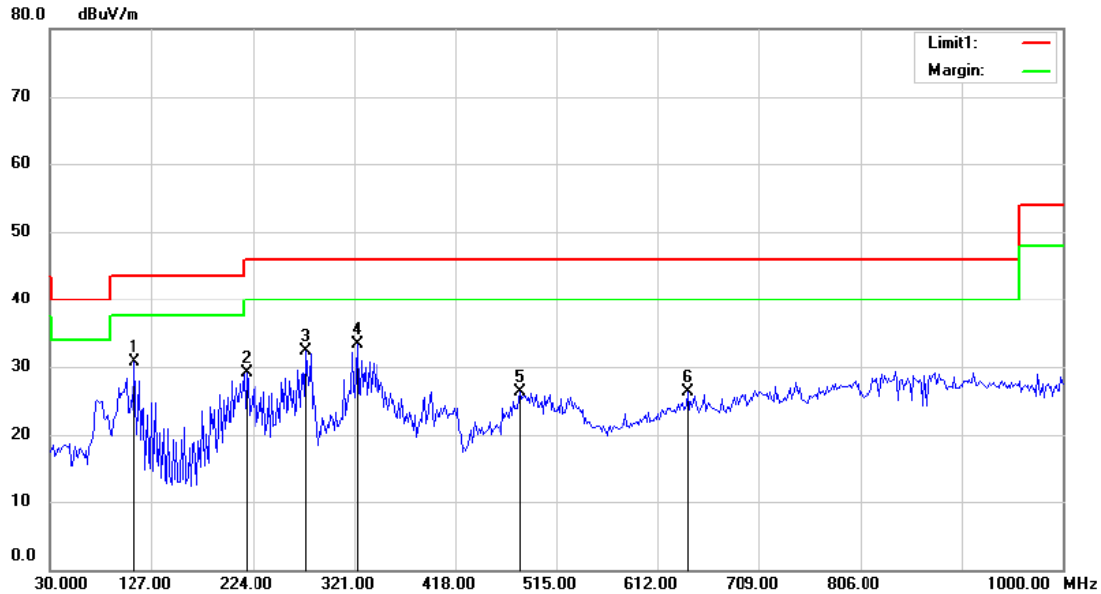

Site site #1 Polarization: **Horizontal** Temperature: 24 C
 Limit: (RE)FCC PART 15 C Power: AC 120V/60Hz Humidity: 53 %
 Mode:TX 2462
 Note:

No.	Mk.	Freq. MHz	Reading Level dBuV	Correct Factor dB	Measure- ment dBuV/m	Limit dBuV/m	Over dB	Detector	Antenna Height cm	Table Degree degree	Comment
1		110.8333	18.17	12.53	30.70	43.50	-12.80	QP			
2		218.0930	18.17	10.90	29.07	46.00	-16.93	QP			
3		275.6090	17.08	15.14	32.22	46.00	-13.78	QP			
4	*	323.7980	18.80	14.60	33.40	46.00	-12.60	QP			
5		480.8012	7.54	18.74	26.28	46.00	-19.72	QP			
6		640.9134	3.50	22.82	26.32	46.00	-19.68	QP			

*:Maximum data x:Over limit !:over margin

Operator: ZHL

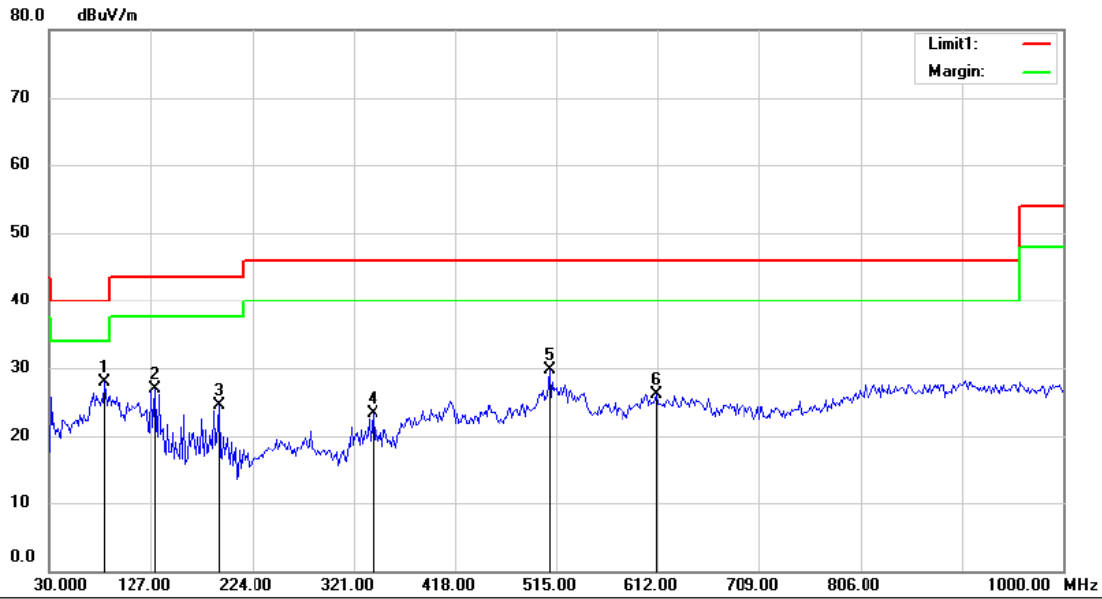

Site site #1 Polarization: **Vertical** Temperature: 24 C
 Limit: (RE)FCC PART 15 C Power: AC 120V/60Hz Humidity: 53 %
 Mode:TX 2462
 Note:

No.	Mk.	Freq. MHz	Reading Level dBuV	Correct Factor dB	Measure- ment dBuV/m	Limit dBuV/m	Over dB	Antenna Height cm	Table Degree	Detector	Comment
1	*	82.8525	19.90	8.04	27.94	40.00	-12.06			QP	
2		131.0415	17.10	9.72	26.82	43.50	-16.68			QP	
3		191.6665	14.27	10.29	24.56	43.50	-18.94			QP	
4		339.3430	7.85	15.46	23.31	46.00	-22.69			QP	
5		508.7820	8.62	20.99	29.61	46.00	-16.39			QP	
6		611.3781	4.55	21.65	26.20	46.00	-19.80			QP	

*:Maximum data x:Over limit !:over margin

Operator: ZHL

Operation Mode: 802.11b TX Channel 1 Test Date : September 09, 2014
 Frequency Range: Above 1GHz Temperature : 28°C
 Test Result: PASS Humidity : 55 %
 Measured Distance: 3m Test By: SYP

Freq. (MHz)	Ant.Pol. H/V	Emission Level(dBuV/m)		Limit 3m(dBuV/m)		Over(dB)	
		PK	AV	PK	AV	PK	AV
3638.08	V	58.91	39.23	74.00	54.00	-15.09	-14.77
4824.00	V	64.38	44.48	74.00	54.00	-9.62	-9.52
6662.11	V	62.00	42.04	74.00	54.00	-12.00	-11.96
7261.47	V	65.87	46.52	74.00	54.00	-8.13	-7.48
7942.56	V	64.47	44.27	74.00	54.00	-9.53	-9.73
9904.10	V	64.01	43.83	74.00	54.00	-9.99	-10.17
3202.18	H	53.70	33.90	74.00	54.00	-20.30	-20.10
4824.00	H	59.00	38.29	74.00	54.00	-15.00	-15.71
5109.23	H	58.80	38.68	74.00	54.00	-15.20	-15.32
7261.47	H	65.32	45.33	74.00	54.00	-8.68	-8.67
9277.50	H	64.51	43.92	74.00	54.00	-9.49	-10.08
9931.34	H	64.68	45.22	74.00	54.00	-9.32	-8.78

All emissions not reported were more than 20dB below the specified limit or in the noise floor.

- Note:**
- (1) All Readings are Peak Value and AV.
 - (2) Emission Level= Reading Level+Probe Factor +Cable Loss.
 - (3) Data of measurement within this frequency range shown “ -- ” in the table above means the reading of emissions are attenuated more than 20dB below the permissible limits or the field strength is too small to be measured.

Operation Mode: 802.11b TX Channel 6 Test Date : September 09, 2014
 Frequency Range: Above 1GHz Temperature : 28°C
 Test Result: PASS Humidity : 55 %
 Measured Distance: 3m Test By: SYP

Freq. (MHz)	Ant.Pol. H/V	Emission Level(dBuV/m)		Limit 3m(dBuV/m)		Over(dB)	
		PK	AV	PK	AV	PK	AV
3682.91	V	56.07	40.70	74.00	54.00	-17.93	-13.30
4884.00	V	61.54	45.95	74.00	54.00	-12.46	-8.05
6706.94	V	59.16	43.51	74.00	54.00	-14.84	-10.49
7306.30	V	63.03	47.99	74.00	54.00	-10.97	-6.01
7987.39	V	61.63	45.74	74.00	54.00	-12.37	-8.26
9948.93	V	61.17	45.30	74.00	54.00	-12.83	-8.70
3247.01	H	50.86	35.37	74.00	54.00	-23.14	-18.63
4884.00	H	60.33	39.76	74.00	54.00	-13.67	-14.24
5154.06	H	55.96	40.15	74.00	54.00	-18.04	-13.85
7306.30	H	62.48	46.80	74.00	54.00	-11.52	-7.20
9322.33	H	61.67	45.39	74.00	54.00	-12.33	-8.61
9976.17	H	61.84	46.69	74.00	54.00	-12.16	-7.31

All emissions not reported were more than 20dB below the specified limit or in the noise floor.

- Note:**
- (1) All Readings are Peak Value and AV.
 - (2) Emission Level= Reading Level+Probe Factor +Cable Loss.
 - (3) Data of measurement within this frequency range shown “ -- ” in the table above means the reading of emissions are attenuated more than 20dB below the permissible limits or the field strength is too small to be measured.

Operation Mode: 802.11b TX (Channel 11) Test Date : September 09, 2014
 Frequency Range: Above 1GHz Temperature : 28°C
 Test Result: PASS Humidity : 55 %
 Measured Distance: 3m Test By: SYP

Freq. (MHz)	Ant.Pol. H/V	Emission Level(dBuV/m)		Limit 3m(dBuV/m)		Over(dB)	
		PK	AV	PK	AV	PK	AV
3728.78	V	58.54	42.17	74.00	54.00	-15.46	-11.83
4924.00	V	64.01	47.42	74.00	54.00	-9.99	-6.58
6752.81	V	61.63	44.98	74.00	54.00	-12.37	-9.02
7352.17	V	65.50	49.46	74.00	54.00	-8.50	-4.54
8033.26	V	64.10	47.21	74.00	54.00	-9.90	-6.79
9994.80	V	63.64	46.77	74.00	54.00	-10.36	-7.23
3292.88	H	53.33	36.84	74.00	54.00	-20.67	-17.16
4924.00	H	62.80	41.23	74.00	54.00	-11.20	-12.77
5199.93	H	58.43	41.62	74.00	54.00	-15.57	-12.38
7352.17	H	64.95	48.27	74.00	54.00	-9.05	-5.73
9368.20	H	64.14	46.86	74.00	54.00	-9.86	-7.14
10457.95	H	65.28	47.33	74.00	54.00	-8.72	-6.67

No others harmonics emissions are higher than 20dB below the limits of 47 CFR Part 15.247.

- Note:**
- (1) All Readings are Peak Value and AV.
 - (2) Emission Level= Reading Level+Probe Factor +Cable Loss.
 - (3) Data of measurement within this frequency range shown “ -- ” in the table above means the reading of emissions are attenuated more than 20dB below the permissible limits or the field strength is too small to be measured.

7. 6dB Bandwidth Test and 99% Bandwidth Test

7.1 Measurement Procedure

1. The testing follows FCC KDB Publication No. 558074 DTS 001 Meas. Guidance v03r02
2. The RF output of EUT was connected to the spectrum analyzer by RF cable and attenuator. The path loss was compensated to the results for each measurement.
3. Set to the maximum power setting and enable the EUT transmit continuously
4. Make the measurement with the spectrum analyzer 's resolution bandwidth (RBW) = 100 kHz. Set the Video bandwidth (VBW) = 300 kHz. In order to make an accurate measurement The 6dB bandwidth must be greater than 500 kHz
5. Measure and record the results in the test report.

7.2 Test SET-UP (Block Diagram of Configuration)

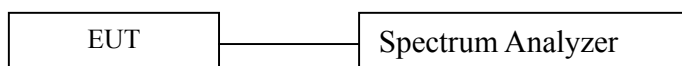

7.3 Measurement Equipment Used

EQUIPMENT TYPE	MFR	MODEL NUMBER	SERIAL NUMBER	LAST CAL.	CAL DUE.
Signal Analyzer	Agilent	N9010A	My53470879	05/17/2014	05/16/2015

7.4 Measurement Results

6db Bandwidth Test Data Chart and 99% Bandwidth Test Data Chart:
 Refer to attached data chart.

6db Bandwidth Test

Spectrum Detector: PK Test Date : September 09, 2014
 Test By: SYP Temperature : 28°C
 Test Result: PASS Humidity : 55 %
 Operation Mode: 802.11b

Channel number	Channel frequency (MHz)	Measurement level (MHz)	Mode	Limit (KHz)
1	2412	10.094	6db Bandwidth	>500
6	2437	10.115	6db Bandwidth	>500
11	2462	10.101	6db Bandwidth	>500

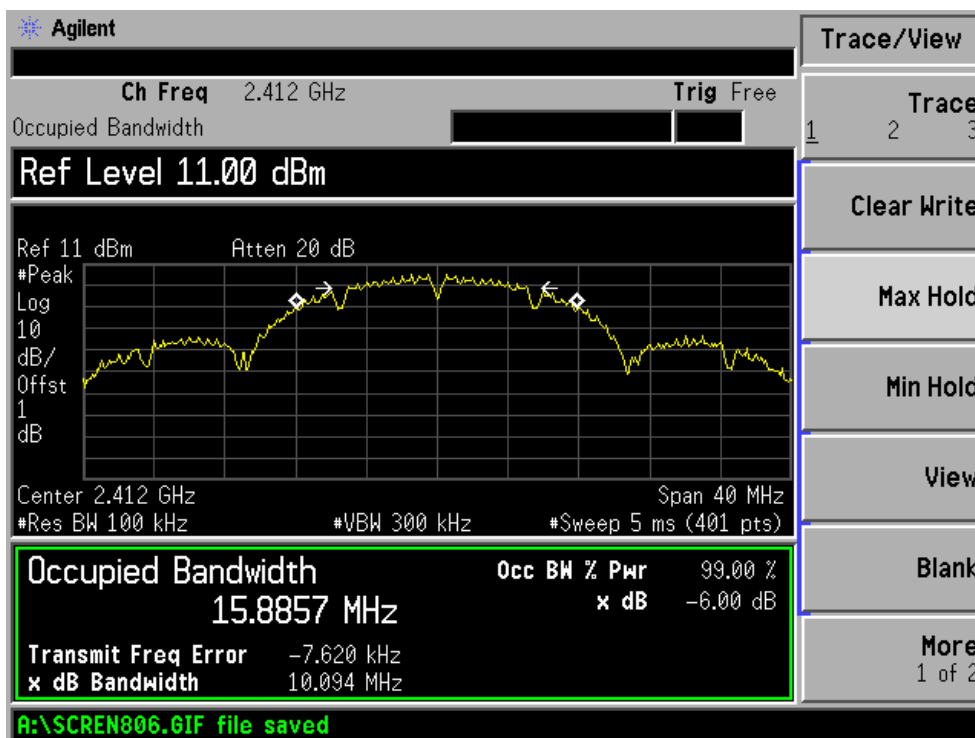

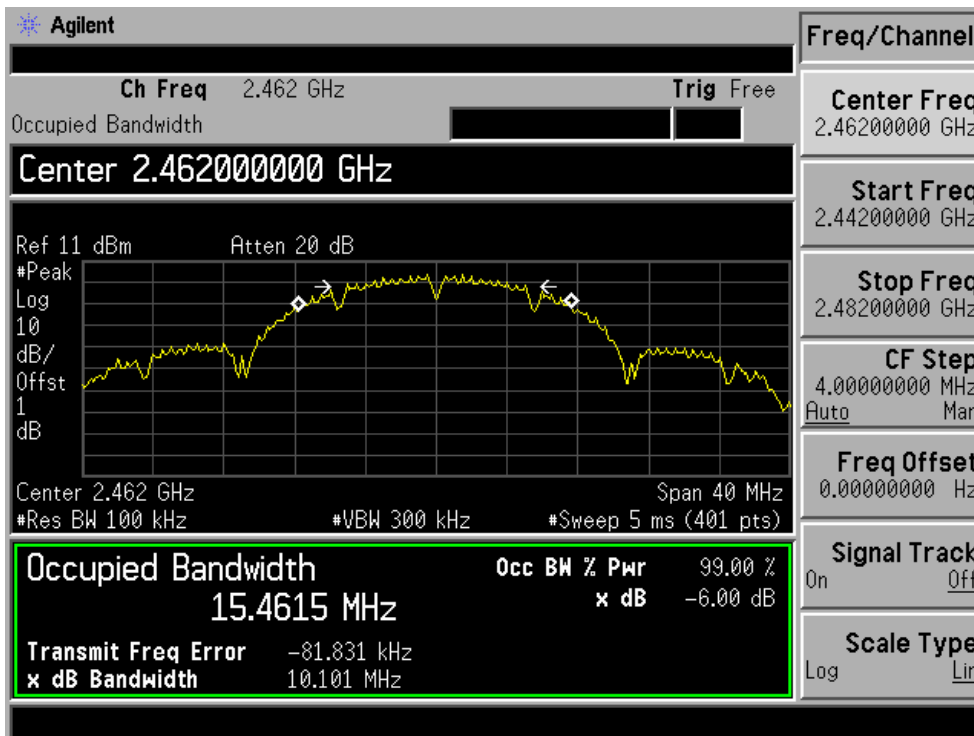
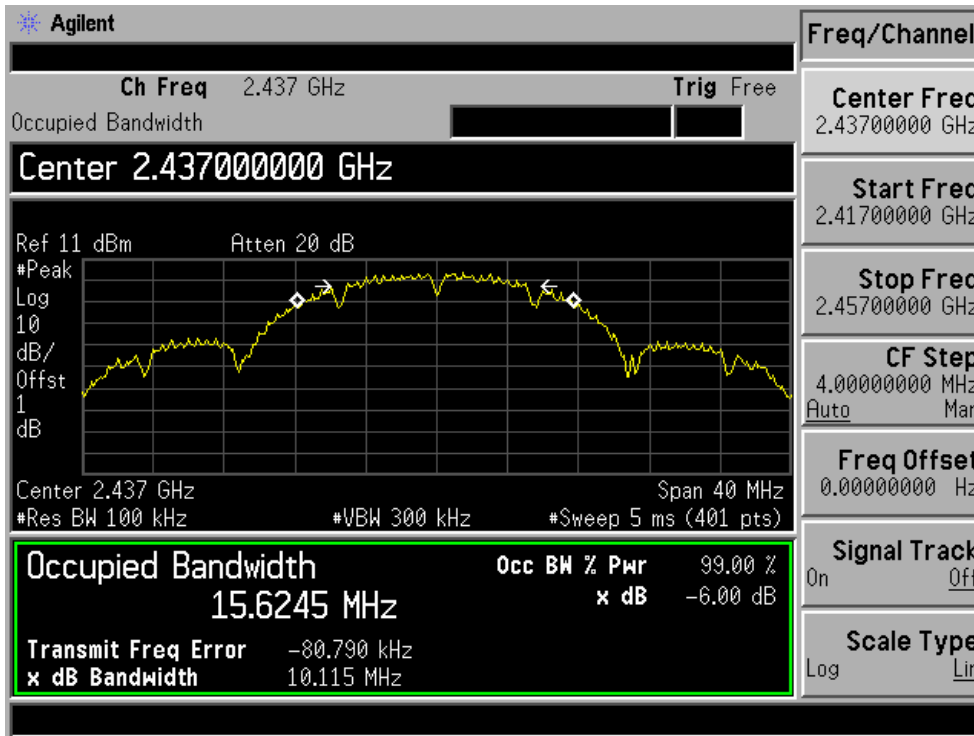

Spectrum Detector: PK Test Date : September 09, 2014
 Test By: SYP Temperature : 28°C
 Test Result: PASS Humidity : 55 %
 Operation Mode: 802.11 g

Channel number	Channel frequency (MHz)	Measurement level (MHz)	Mode	Limit (KHz)
1	2412	16.422	6db Bandwidth	>500
6	2437	16.441	6db Bandwidth	>500
11	2462	16.475	6db Bandwidth	>500

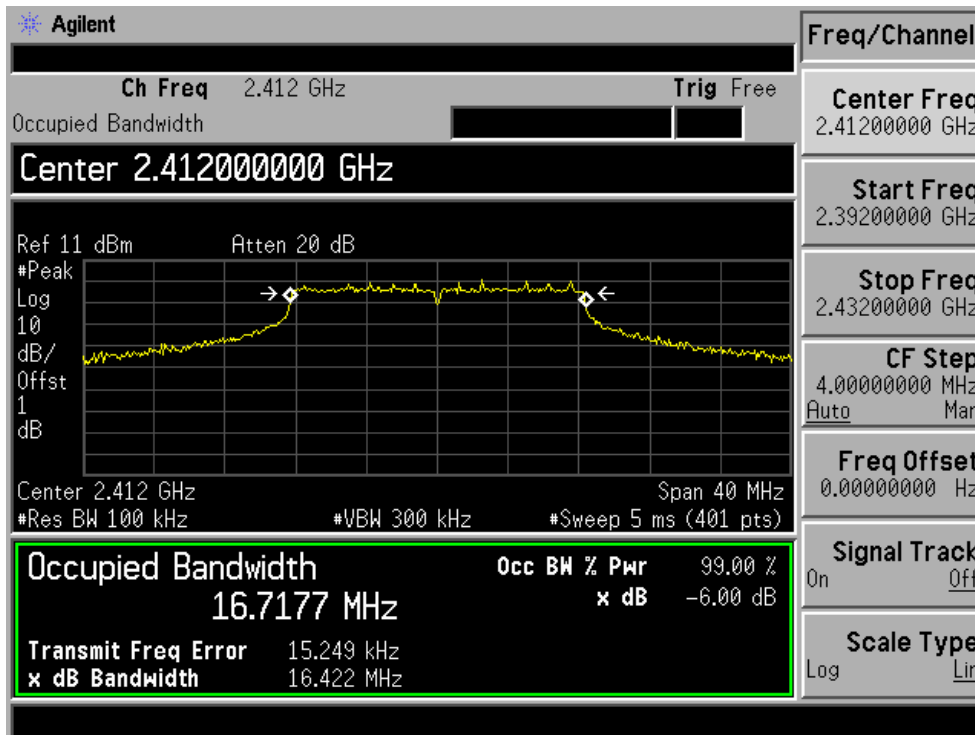

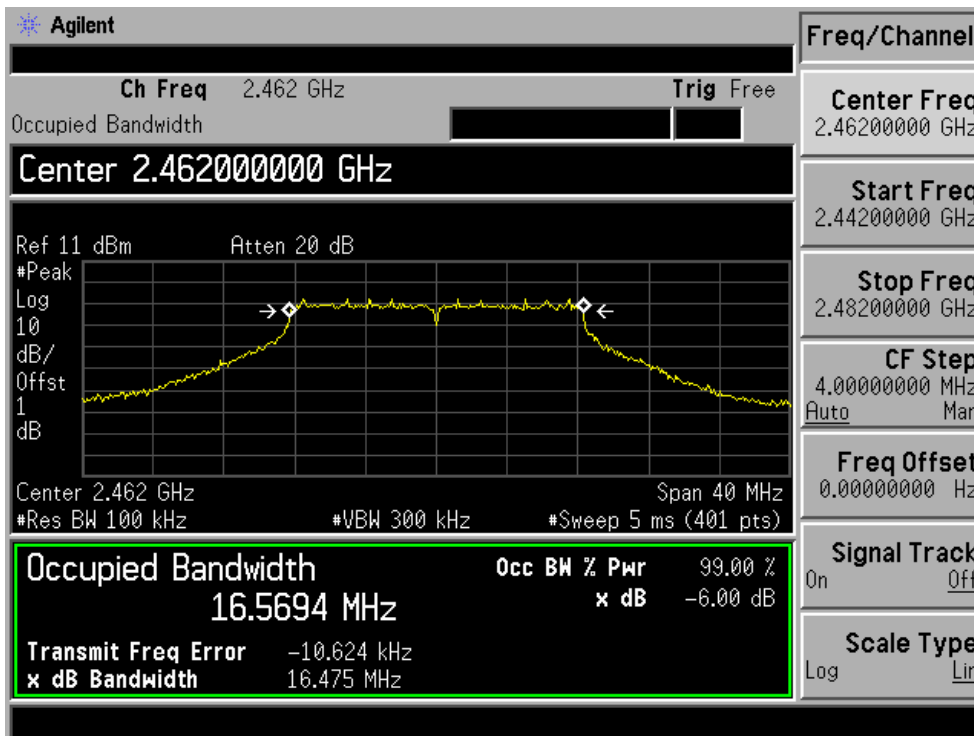
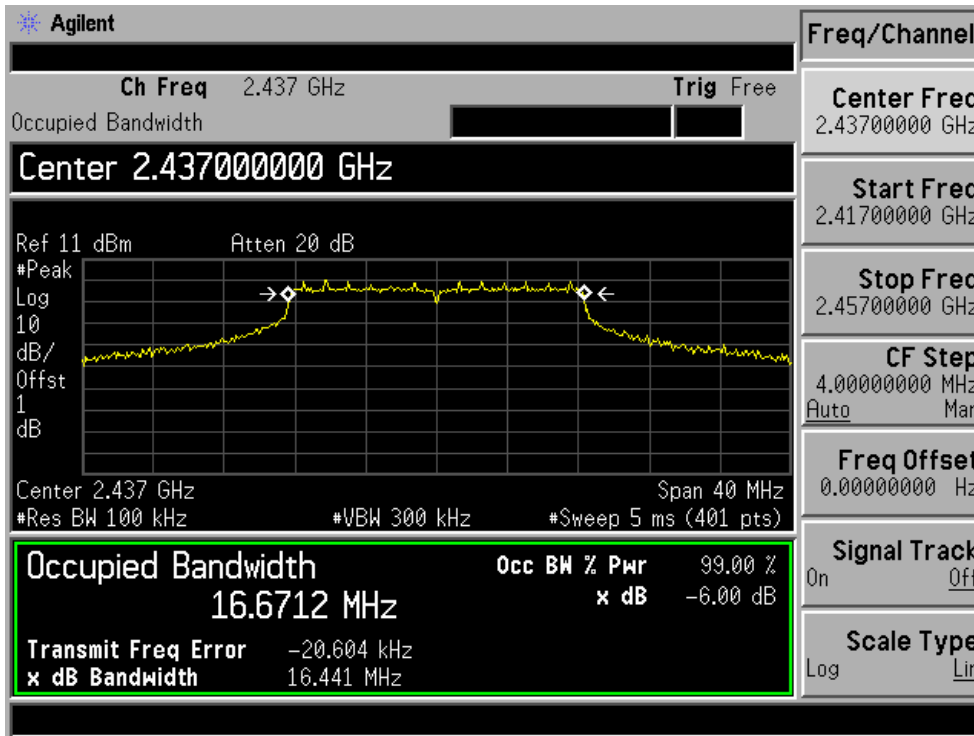

Spectrum Detector: PK Test Date : September 09, 2014
 Test By: SYP Temperature : 28°C
 Test Result: PASS Humidity : 55 %
 Operation Mode: 802.11 n HT20

Channel number	Channel frequency (MHz)	Measurement level (MHz)	Mode	Limit (KHz)
1	2412	17.682	6db Bandwidth	>500
6	2437	17.685	6db Bandwidth	>500
11	2462	17.662	6db Bandwidth	>500

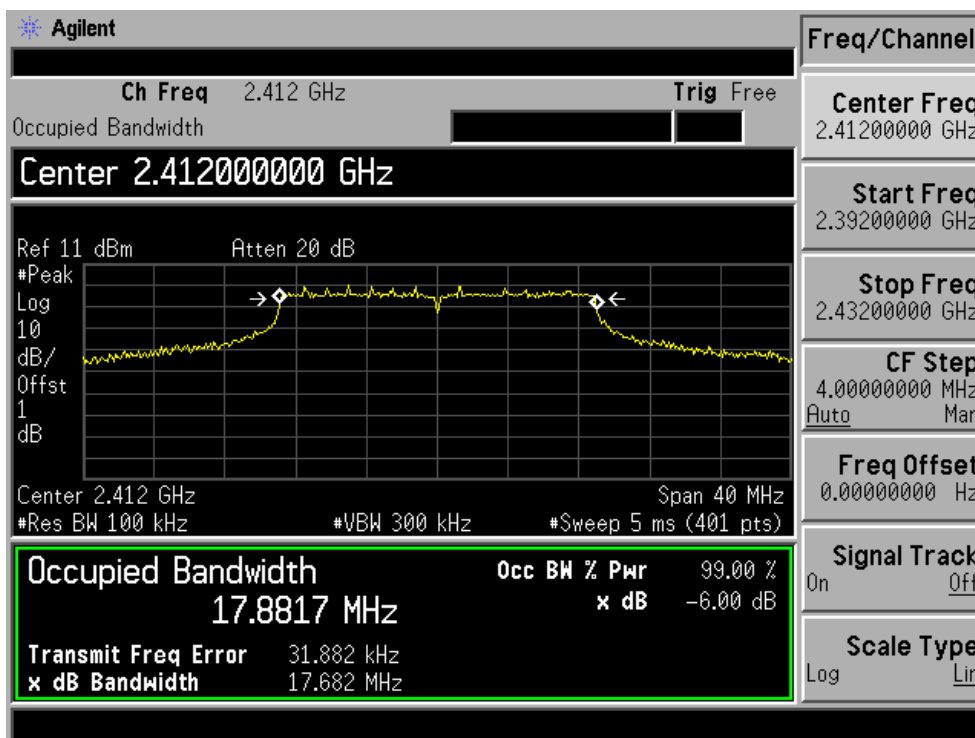

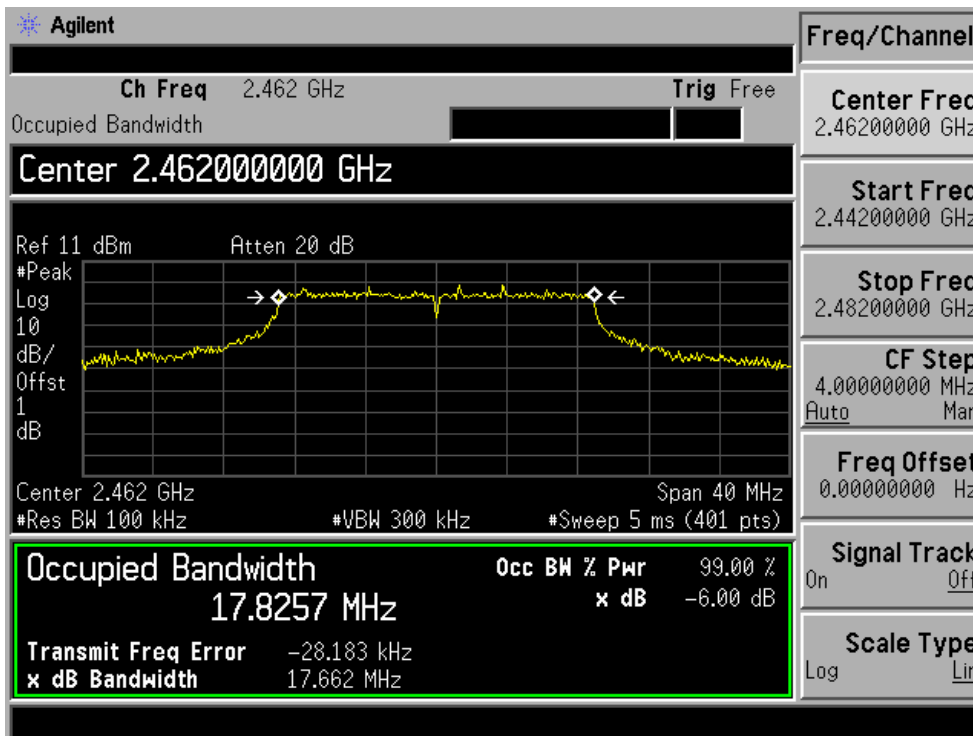
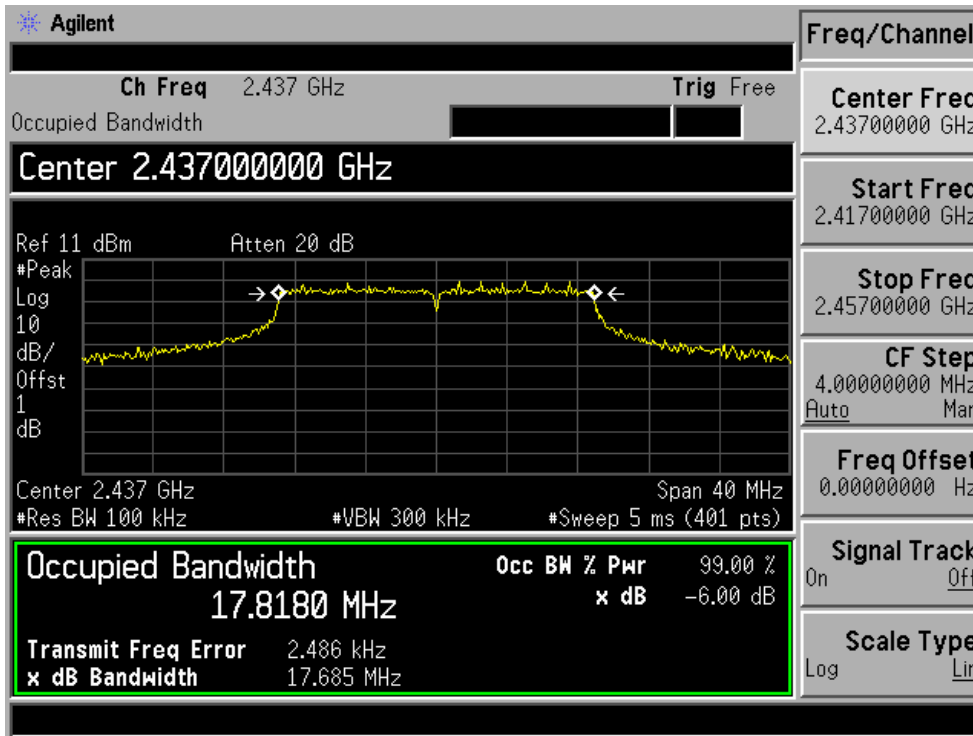

Spectrum Detector: PK Test Date : September 09, 2014
 Test By: SYP Temperature : 28°C
 Test Result: PASS Humidity : 55 %
 Operation Mode: 802.11 n HT40

Channel number	Channel frequency (MHz)	Measurement level (MHz)	Mode	Limit (KHz)
3	2422	35.668	6db Bandwidth	>500
6	2437	35.682	6db Bandwidth	>500
9	2452	35.404	6db Bandwidth	>500

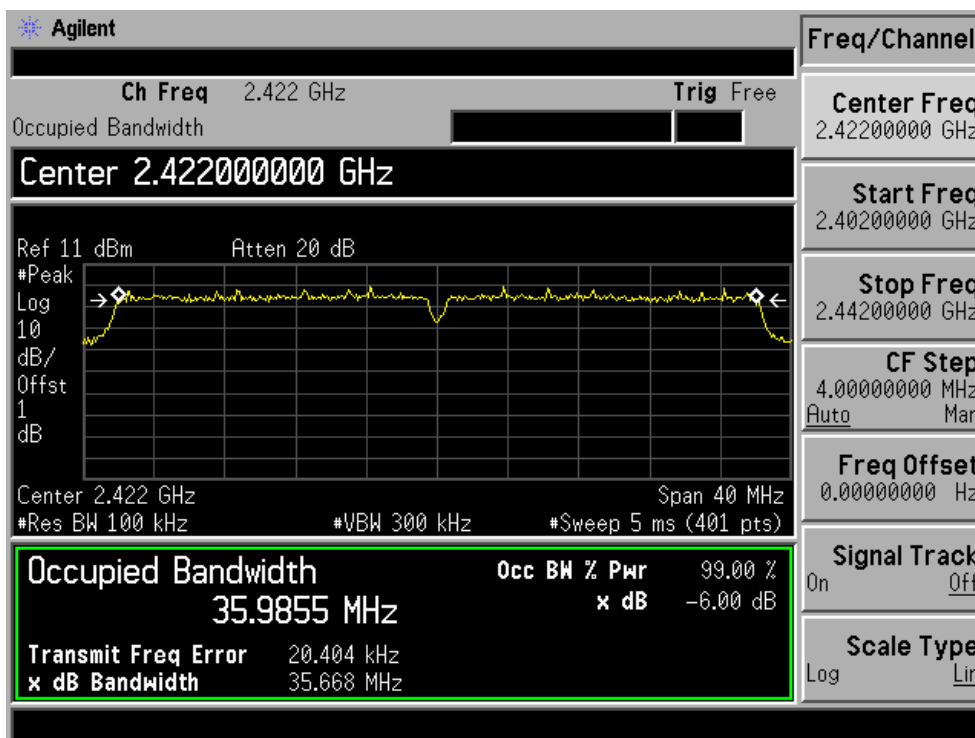

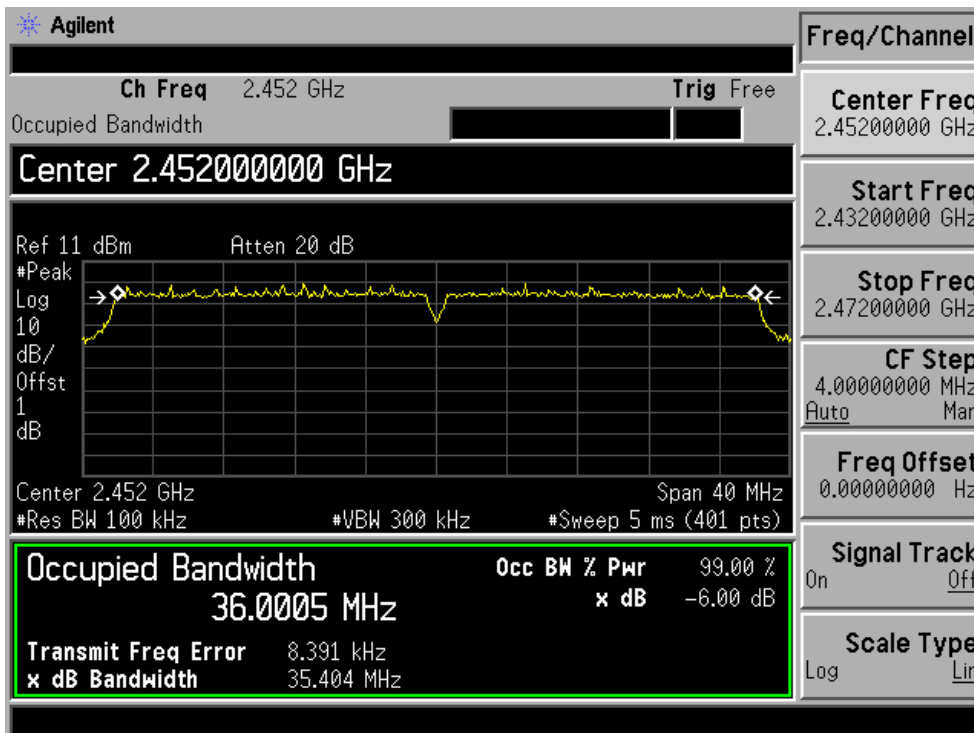
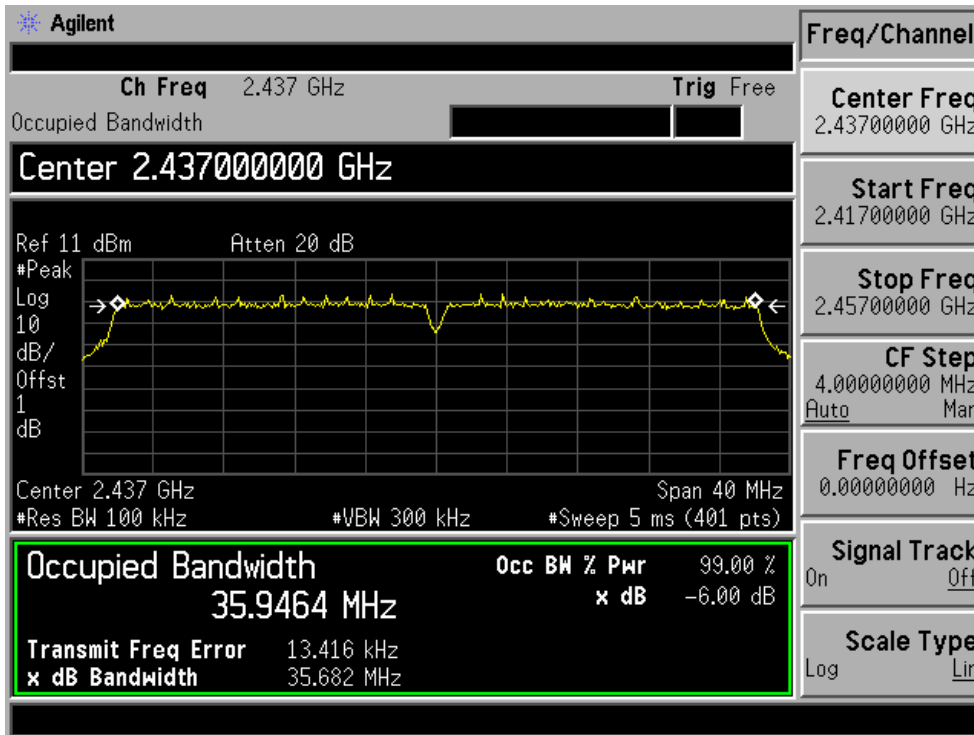

99% Bandwidth Test

Spectrum Detector:	PK	Test Date :	September 09, 2014
Test By:	SYP	Temperature :	28°C
Test Result:	PASS	Humidity :	55 %
Operation Mode:	802.11b		

Channel number	Channel frequency (MHz)	Measurement level (MHz)	Mode
1	2412	15.6594	99% Bandwidth Test
6	2437	15.5636	99% Bandwidth Test
11	2462	15.5525	99% Bandwidth Test

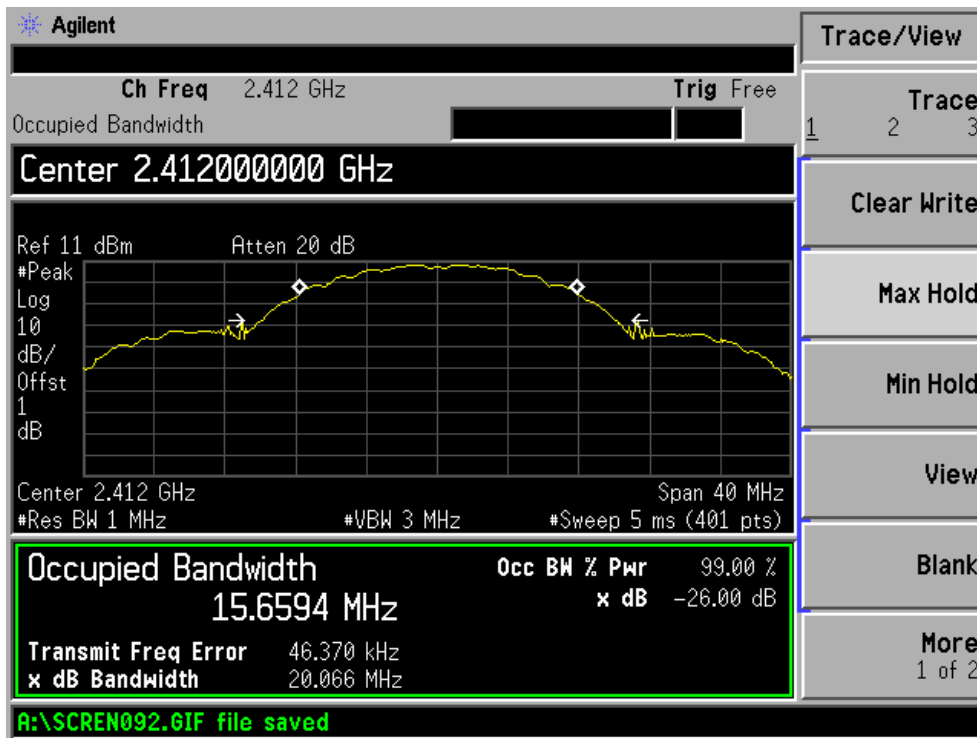

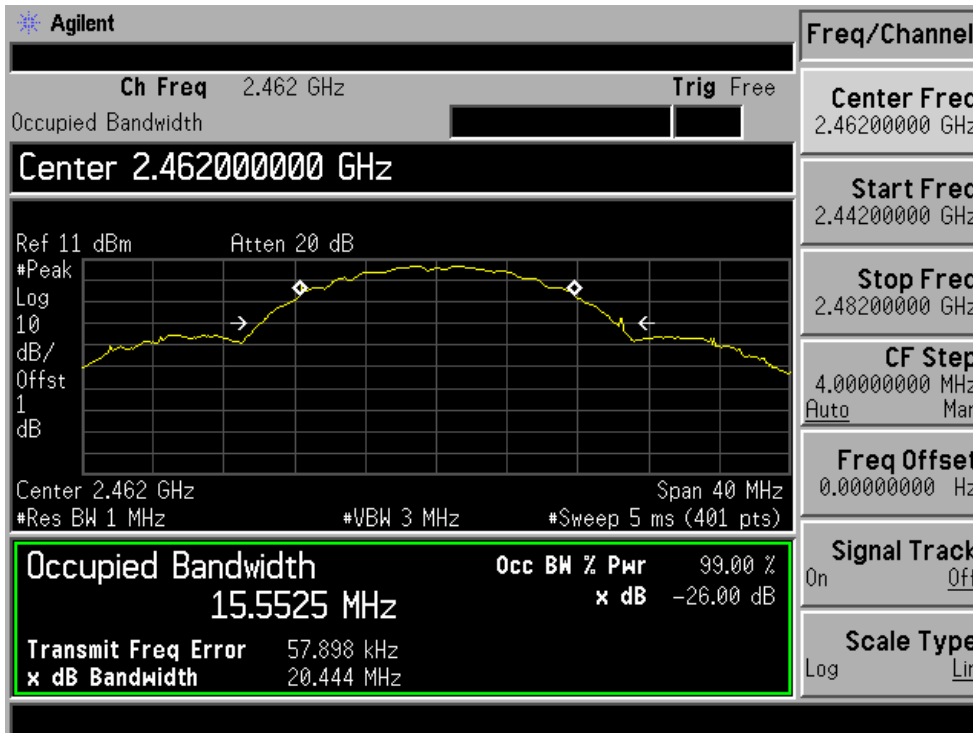
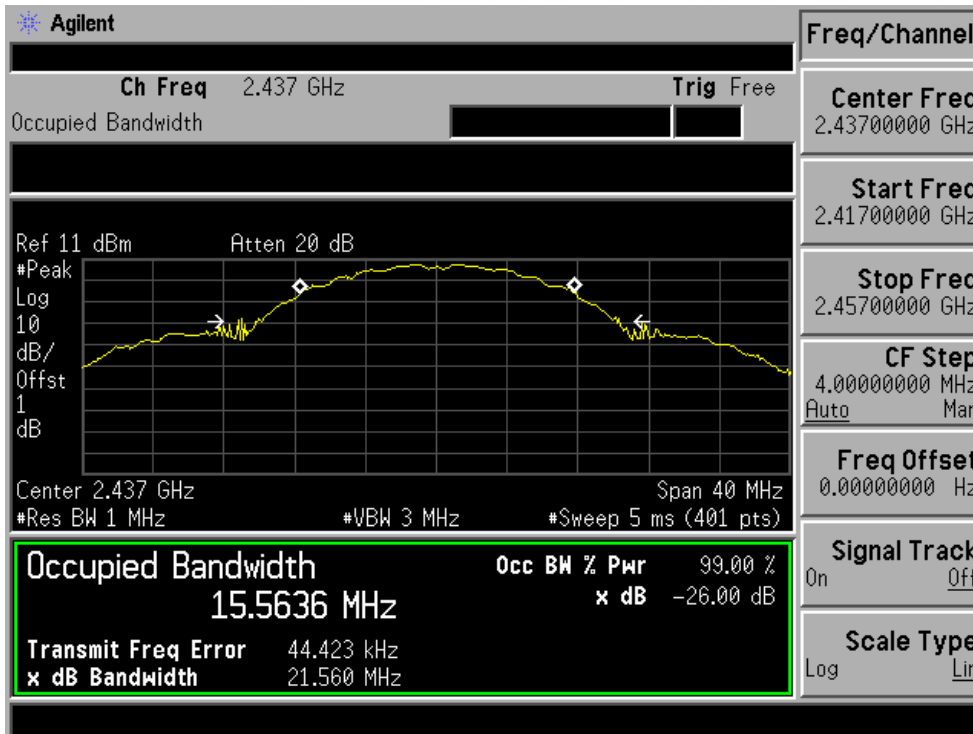

Spectrum Detector: PK Test Date : September 09, 2014
 Test By: SYP Temperature : 28°C
 Test Result: PASS Humidity : 55 %
 Operation Mode: 802.11 g

Channel number	Channel frequency (MHz)	Measurement level (MHz)	Mode
1	2412	19.4403	99% Bandwidth Test
6	2437	19.6243	99% Bandwidth Test
11	2462	19.5241	99% Bandwidth Test

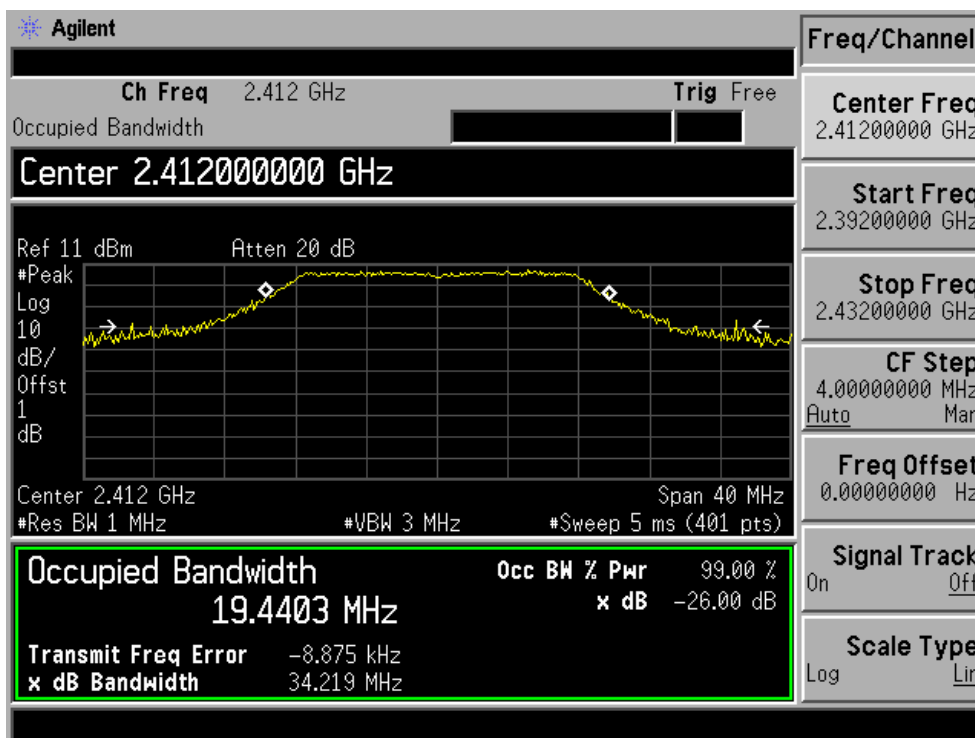

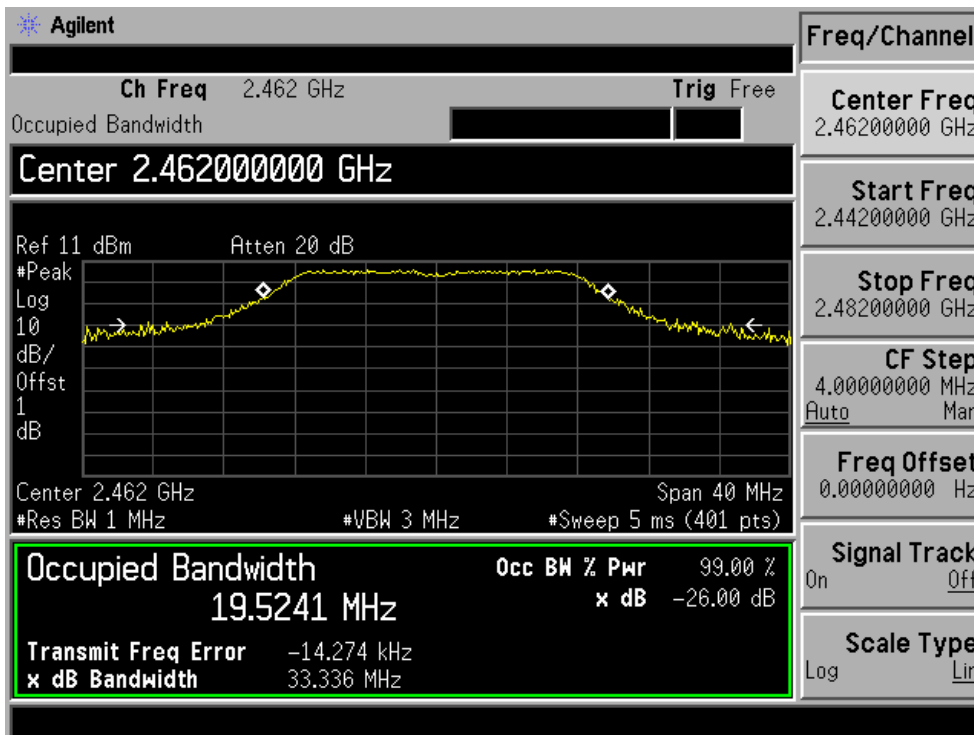
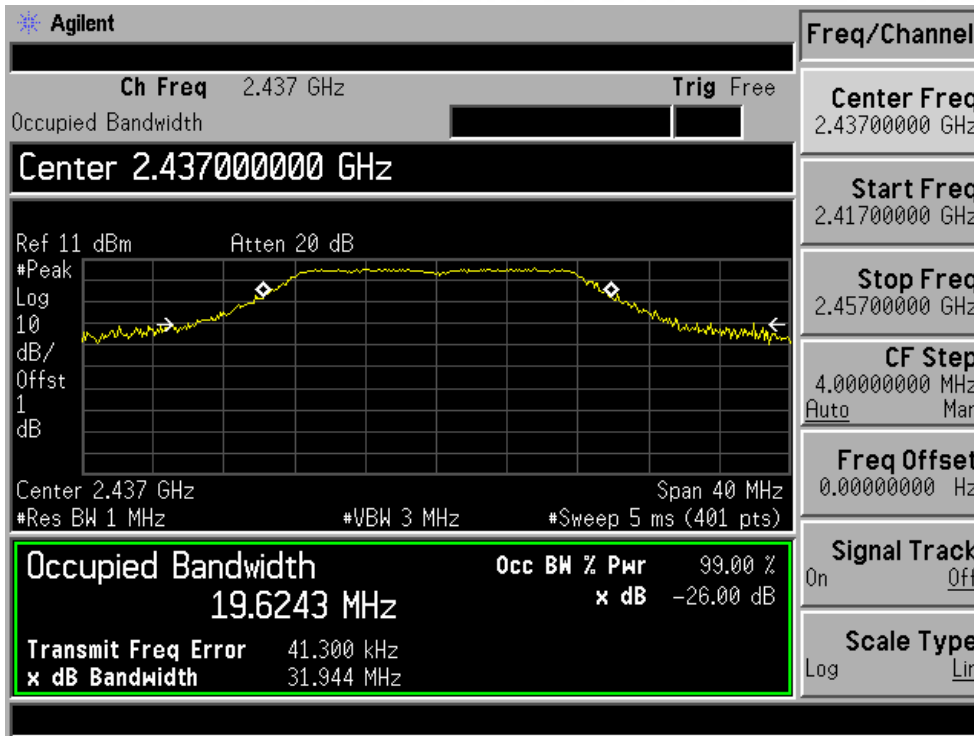

Spectrum Detector: PK Test Date : September 09, 2014
 Test By: SYP Temperature : 28°C
 Test Result: PASS Humidity : 55 %
 Operation Mode: 802.11 n HT20

Channel number	Channel frequency (MHz)	Measurement level (MHz)	Mode
1	2412	20.5653	99% Bandwidth Test
6	2437	20.5516	99% Bandwidth Test
11	2462	20.4138	99% Bandwidth Test

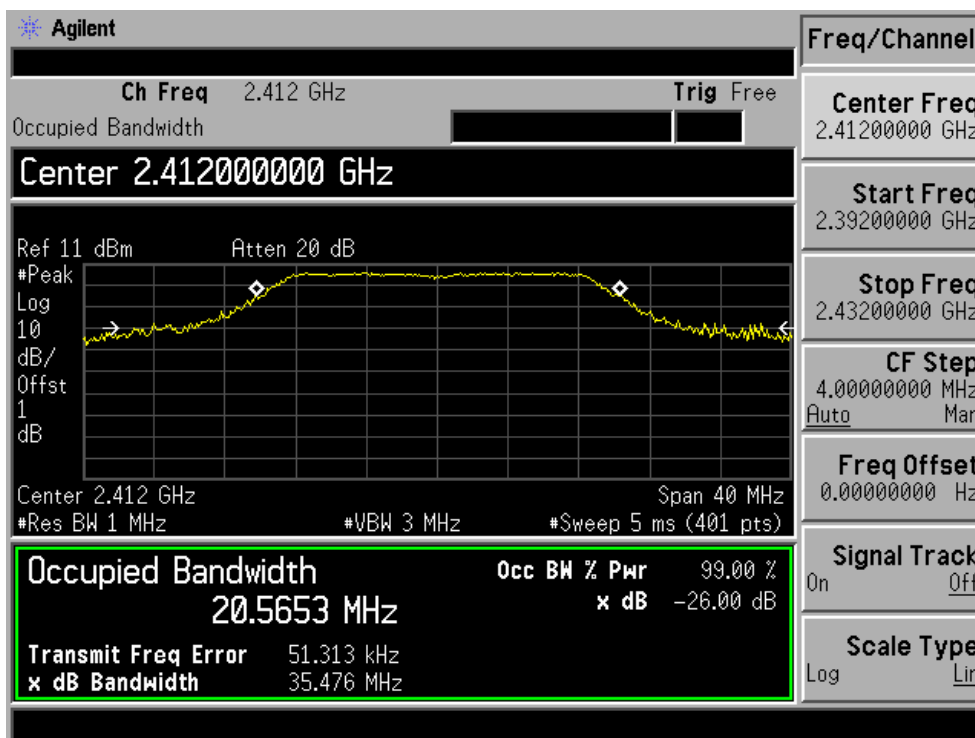

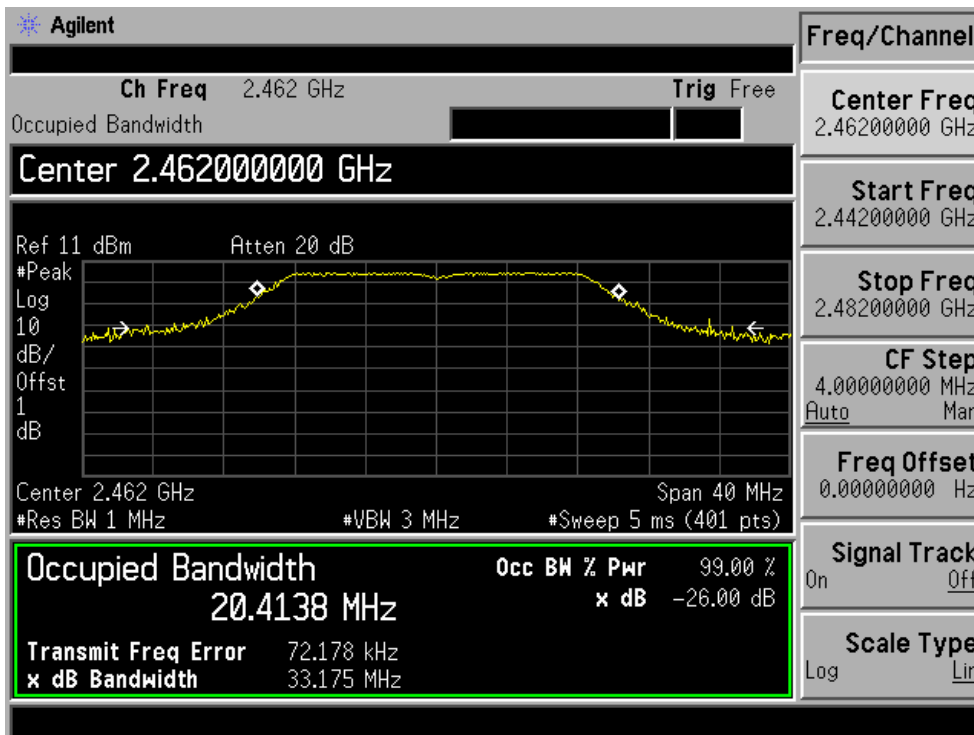
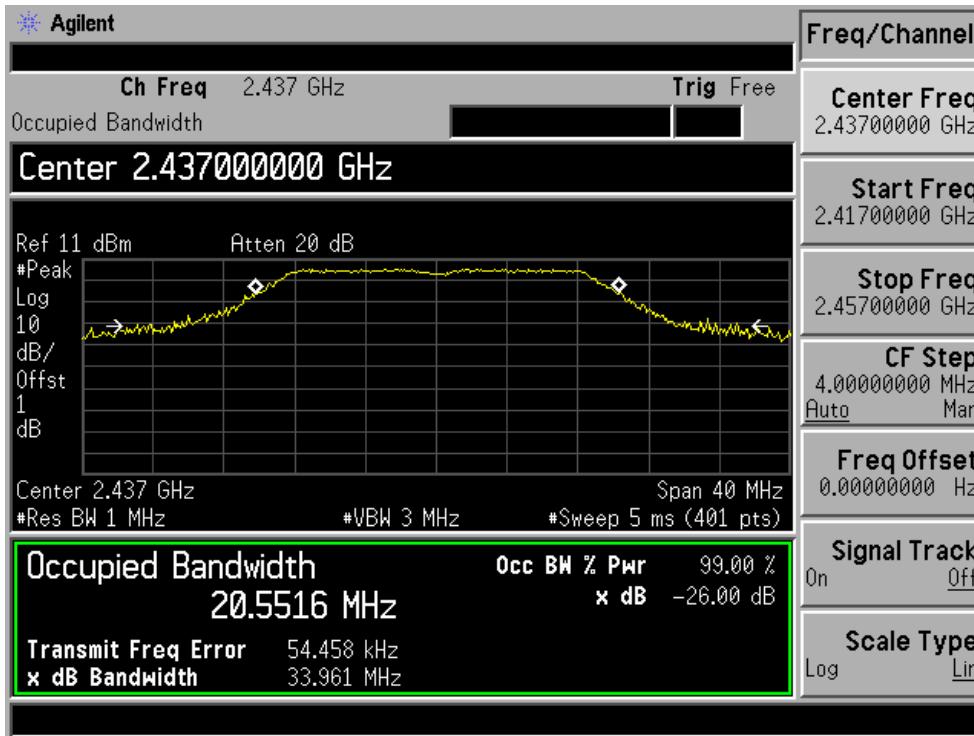

Spectrum Detector:	PK	Test Date :	September 09, 2014
Test By:	SYP	Temperature :	28°C
Test Result:	PASS	Humidity :	55 %
Operation Mode:	802.11 n HT40		

Channel number	Channel frequency (MHz)	Measurement level (MHz)	Mode
3	2422	36.4246	99% Bandwidth Test
6	2437	36.4219	99% Bandwidth Test
9	2452	36.4465	99% Bandwidth Test

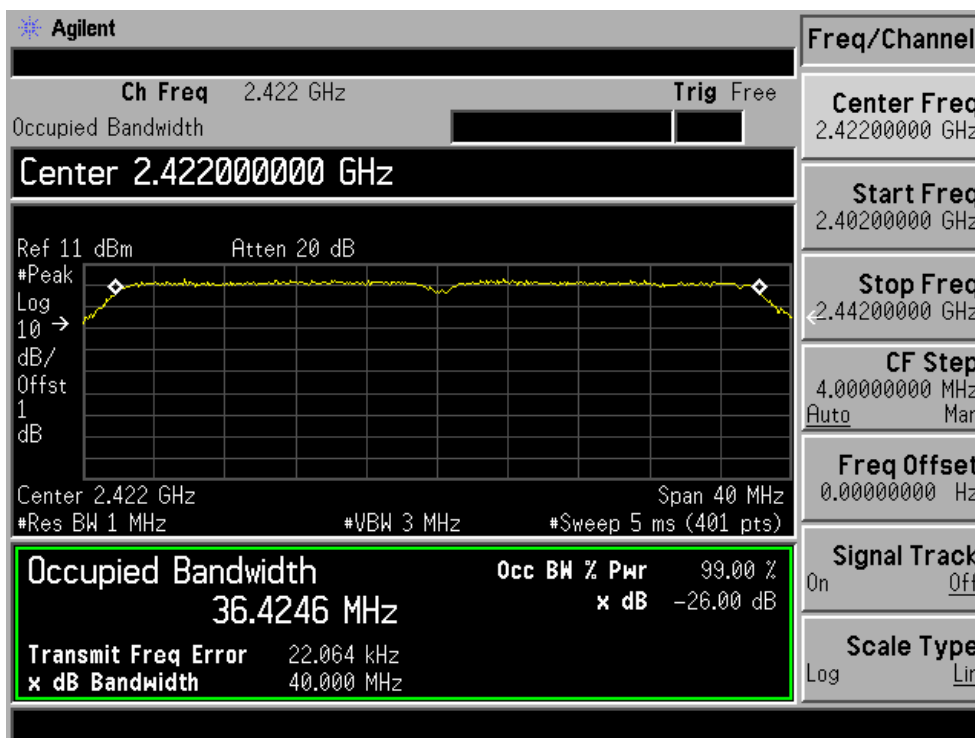

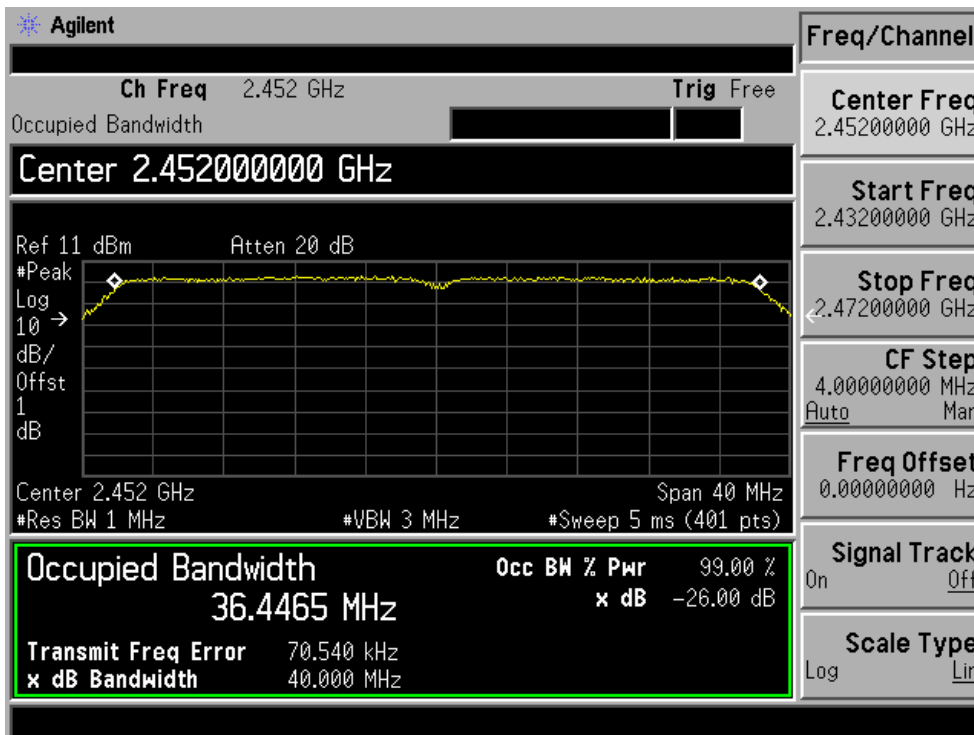
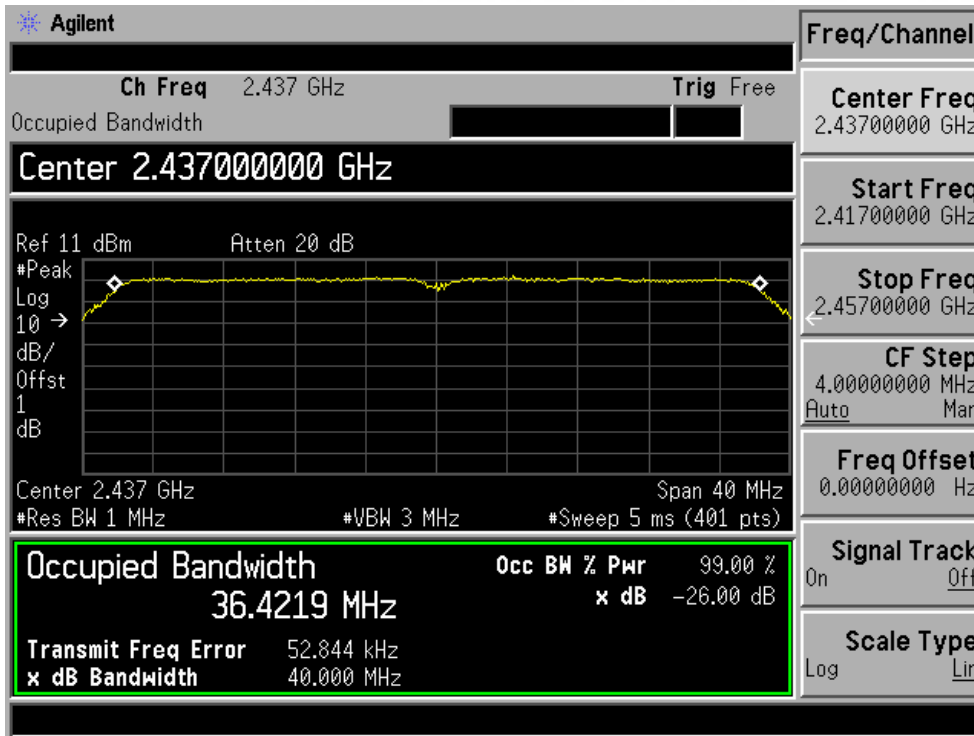

8. Maximum Peak Output Power Test

8.1 Measurement Procedure

The maximum peak conducted output power can be measured using a broadband peak RF power meter. The power meter must have a video bandwidth that is greater than or equal to the DTS bandwidth and shall utilize a fast, average-responding diode type sensor.

- a. The Transmitter output (antenna port) was connected to the power meter.
- b. Turn on the EUT and power meter and then record the peak power value.
- c. Repeat above procedures on all channels needed to be tested.

8.2 Test SET-UP (Block Diagram of Configuration)

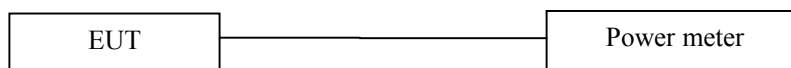

8.3 Measurement Equipment Used

EQUIPMENT TYPE	MODEL NUMBER	SERIAL NUMBER	LAST CAL.	CAL DUE.
Power meter	ML2495A	0824006	05/17/2014	05/16/2015
Power sensor	MA2411B	0738172	05/17/2014	05/16/2015

8.4 Peak Power output limit

The maximum peak power shall be less 1Watt.

8.5 Measurement Results

Spectrum Detector: PK Test Date : September 09, 2014
 Test By: SYP Temperature : 28°C
 Test Result: PASS Humidity : 55 %
 Operation Mode: 802.11b

Channel number	Channel Frequency(MHz)	Peak Power output(dBm)	Peak Power Limit(W)	Pass/Fail
1	2412	9.83	1W(30dBm)	PASS
6	2437	9.20	1W(30dBm)	PASS
11	2462	9.44	1W(30dBm)	PASS

Spectrum Detector: PK Test Date : September 09, 2014
 Test By: SYP Temperature : 28°C
 Test Result: PASS Humidity : 55 %
 Operation Mode: 802.11g

Channel number	Channel Frequency (MHz)	Peak Power output(dBm)	Peak Power Limit(W)	Pass/Fail
1	2412.00	8.97	1W(30dBm)	PASS
6	2437.00	9.23	1W(30dBm)	PASS
11	2462.00	9.05	1W(30dBm)	PASS

Spectrum Detector: PK Test Date : September 09, 2014
 Test By: SYP Temperature : 28°C
 Test Result: PASS Humidity : 55 %
 Operation Mode: 802.11n H20

Channel number	Channel Frequency (MHz)	Peak Power output(dBm)	Peak Power Limit(W)	Pass/Fail
1	2412.00	9.61	1W(30dBm)	PASS
6	2437.00	9.46	1W(30dBm)	PASS
11	2462.00	9.29	1W(30dBm)	PASS

Spectrum Detector: PK Test Date : September 09, 2014
 Test By: SYP Temperature : 28°C
 Test Result: PASS Humidity : 55 %
 Operation Mode: 802.11n H40

Channel number	Channel Frequency (MHz)	Peak Power output(dBm)	Peak Power Limit(W)	Pass/Fail
3	2422.00	9.55	1W(30dBm)	PASS
6	2437.00	9.47	1W(30dBm)	PASS
9	2452.00	9.38	1W(30dBm)	PASS

9. Band Edge Test

9.1 Measurement Procedure

1. The EUT was Operating in hopping mode or could be controlled its channel. Printed out test result from the spectrum by hard copy function.
2. The EUT was placed on a turn table which is 0.8m above ground plane.
3. Maximum procedure was performed on the six highest emissions to ensure EUT compliance.
4. And also, each emission was to be maximized by changing the polarization of receiving antenna both horizontal and vertical.
5. Repeat above procedures until all frequency measured were complete.

When spectrum scanned above 1GHz setting resolution bandwidth 1MHz, video bandwidth 3MHz.

EMI Test Receiver	Setting
Attenuation	Auto
RB	1MHz
VB	3MHz
Detector	Peak
Trace	Max hold

When spectrum scanned above 1GHz setting resolution bandwidth 1MHz, video bandwidth 10Hz.

EMI Test Receiver	Setting
Attenuation	Auto
RB	1MHz
VB	10Hz
Detector	AVG
Trace	Max hold

9.2 Test SET-UP (Block Diagram of Configuration)

As 6.2 Test set up (B) and (C)

9.3 Measurement Equipment Used

Same as 6.3 Radiated Emission Measurement.

9.4 Measurement Results

Test mode: 802.11b

Spectrum Detector: PK/AV Test Date : September 09, 2014
 Test By: SYP Temperature : 28°C
 Test channel: 01 Humidity : 55 %

Frequency (MHz)	Polarity	Level (dBuV/m)		Limited (dBuV/m)	
		PK	AV	PK	AV
2390.00	H	45.54	32.55	74	54
2394.50	V	41.45	36.77	74	54

Spectrum Detector: PK/AV Test Date : September 09, 2014
 Test By: SYP Temperature : 28°C
 Test channel: 11 Humidity : 55 %

Frequency (MHz)	Polarity	Level (dBuV/m)		Limited (dBuV/m)	
		PK	AV	PK	AV
2484.50	H	44.78	33.47	74	54
2486.87	V	43.66	35.84	74	54

Test mode: 802.11g

Spectrum Detector: PK/AV Test Date : September 09, 2014
 Test By: SYP Temperature : 28°C
 Test channel: 01 Humidity : 55 %

Frequency (MHz)	Polarity	Level (dBuV/m)		Limited (dBuV/m)	
		PK	AV	PK	AV
2390.42	H	48.77	35.43	74	54
2392.25	V	47.62	32.69	74	54

Spectrum Detector: PK/AV Test Date : September 09, 2014
 Test By: SYP Temperature : 28°C
 Test channel: 11 Humidity : 55 %

Frequency (MHz)	Polarity	Level (dBuV/m)		Limited (dBuV/m)	
		PK	AV	PK	AV
2485.50	H	45.29	35.59	74	54
2485.50	V	44.69	33.58	74	54

Test mode: 802.11n HT20

Spectrum Detector: PK/AV Test Date : September 09, 2014
 Test By: SYP Temperature : 28°C
 Test channel: 01 Humidity : 55 %

Frequency (MHz)	Polarity	Level (dBuV/m)		Limited (dBuV/m)	
		PK	AV	PK	AV
2391.25	H	46.40	33.29	74	54
2390.00	V	45.04	36.23	74	54

Spectrum Detector: PK/AV Test Date : September 09, 2014
 Test By: SYP Temperature : 28°C
 Test channel: 11 Humidity : 55 %

Frequency (MHz)	Polarity	Level (dBuV/m)		Limited (dBuV/m)	
		PK	AV	PK	AV
2484.50	H	45.44	35.97	74	54
2484.33	V	42.51	34.19	74	54

Test mode: 802.11n HT40

Spectrum Detector: PK/AV Test Date : September 09, 2014
 Test By: SYP Temperature : 28°C
 Test channel: 03 Humidity : 55 %

Frequency (MHz)	Polarity	Level (dBuV/m)		Limited (dBuV/m)	
		PK	AV	PK	AV
2390.00	H	47.69	33.33	74	54
2391.54	V	44.58	35.99	74	54

Spectrum Detector: PK/AV Test Date : September 09, 2014
 Test By: SYP Temperature : 28°C
 Test channel: 09 Humidity : 55 %

Frequency (MHz)	Polarity	Level (dBuV/m)		Limited (dBuV/m)	
		PK	AV	PK	AV
2484.50	H	45.59	37.88	74	54
2485.60	V	42.32	34.19	74	54

10. Power Density

10.1 Test Equipment

EQUIPMENT TYPE	MFR	MODEL NUMBER	SERIAL NUMBER	LAST CAL.	CAL DUE.
Signal Analyzer	Agilent	N9010A	My53470879	05/17/2014	05/16/2015

10.2 Measuring Instruments and Setting

The following table is the setting of spectrum analyzer.

Spectrum analyzer	Setting
Attenuation	Auto
Span Frequency	Set the span to 1.5 times the DTS bandwidth.
RB	$3\text{KHz} \leq \text{RBW} \leq 100\text{KHz}$
VB	3 x RBW
Detector	Peak
Trace	Max hold
Sweep Time	Automatic

10.3 Test Procedures

- The transmitter output (antenna port) was connected to the spectrum analyzer.
- Set analyzer center frequency to DTS channel center frequency.
- Set the analyzer span to a minimum of 1.5 times the DTS bandwidth.
- Set the $3\text{KHz} \leq \text{RBW} \leq 100\text{KHz}$.
- Detector = peak.
- Sweep time = auto couple.
- Trace mode = max hold.
- Allow trace to fully stabilize.
- Use the peak marker function to determine the maximum amplitude level within the RBW.

10.4 Block Diagram of Test Setup

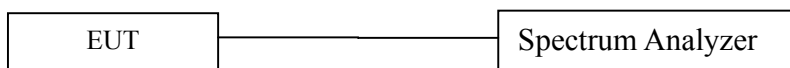

10.5 Limit

The transmitted power density averaged over any 1 second interval shall not be greater +8dBm in any 3 kHz bandwidth.

10.6 Test Result

Spectrum Detector:	PK	Test Date :	September 09, 2014
Test By:	SYP	Temperature :	28°C
Test Result:	PASS	Humidity :	55 %
Operation Mode:	802.11 b		

Channel	Measurement Level (dBm)	Required Limit (dBm)	Result
1	-6.560	<8dBm	PASS
6	-7.145	<8dBm	PASS
11	-6.011	<8dBm	PASS

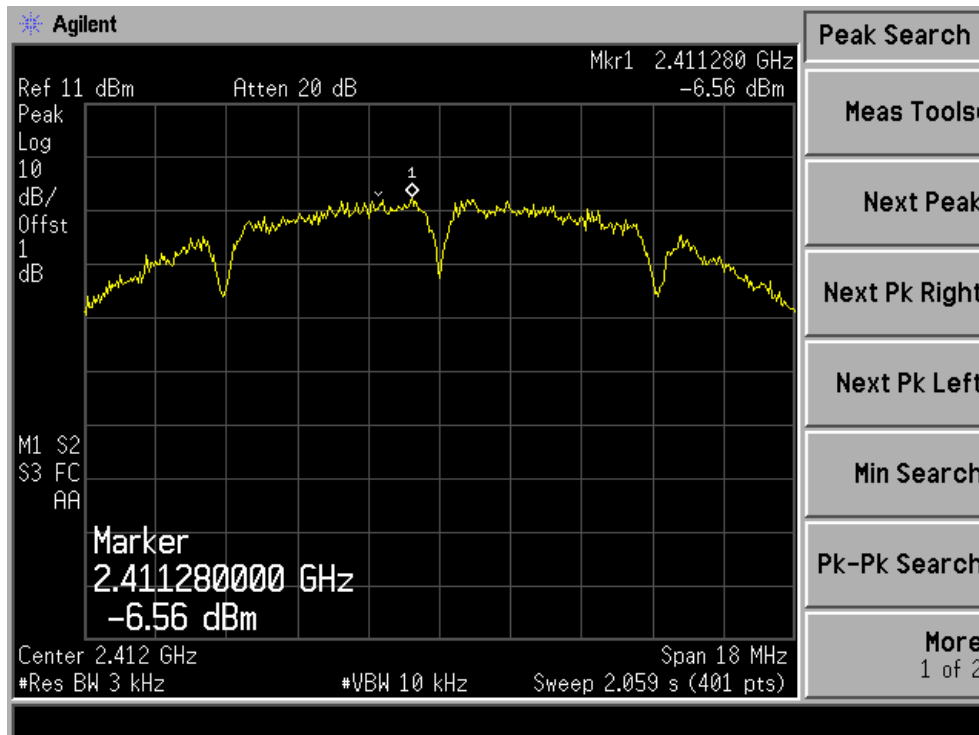

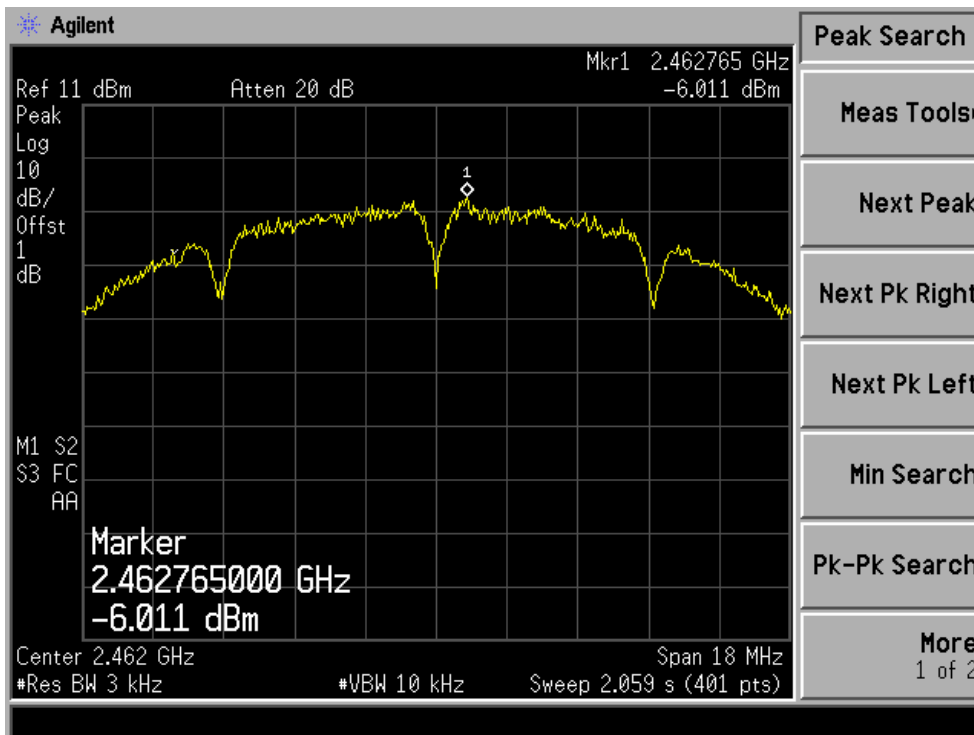
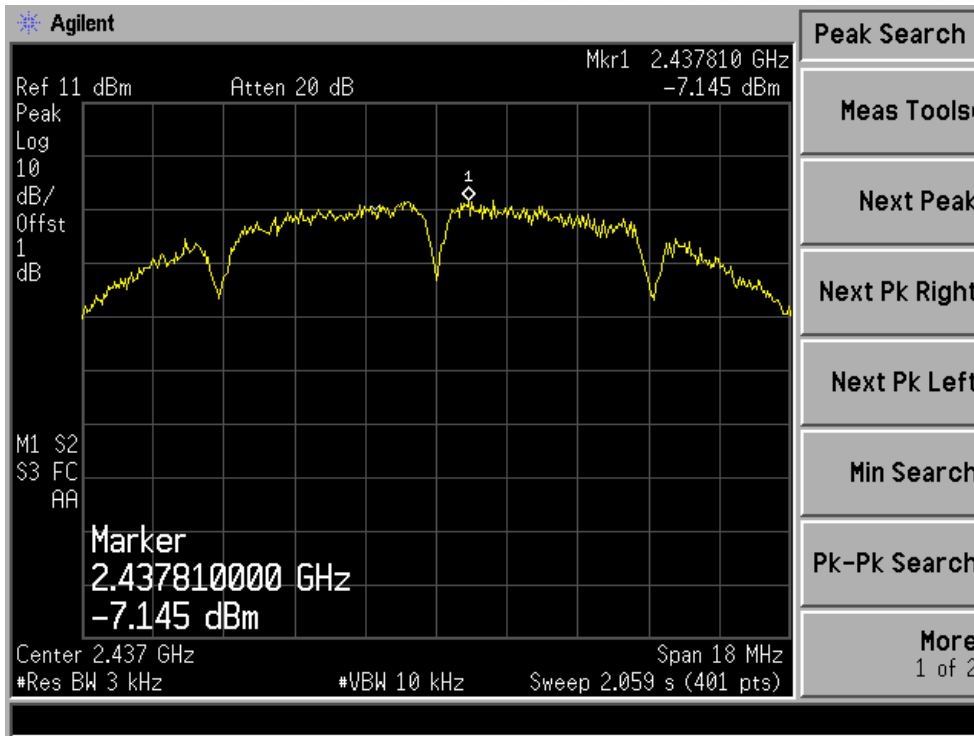

Spectrum Detector: PK Test Date : September 09, 2014
 Test By: SYP Temperature : 28°C
 Test Result: PASS Humidity : 55 %
 Operation Mode: 802.11 g

Channel	Measurement Level (dBm)	Required Limit (dBm)	Result
1	-12.07	<8dBm	PASS
6	-11.91	<8dBm	PASS
11	-12.24	<8dBm	PASS

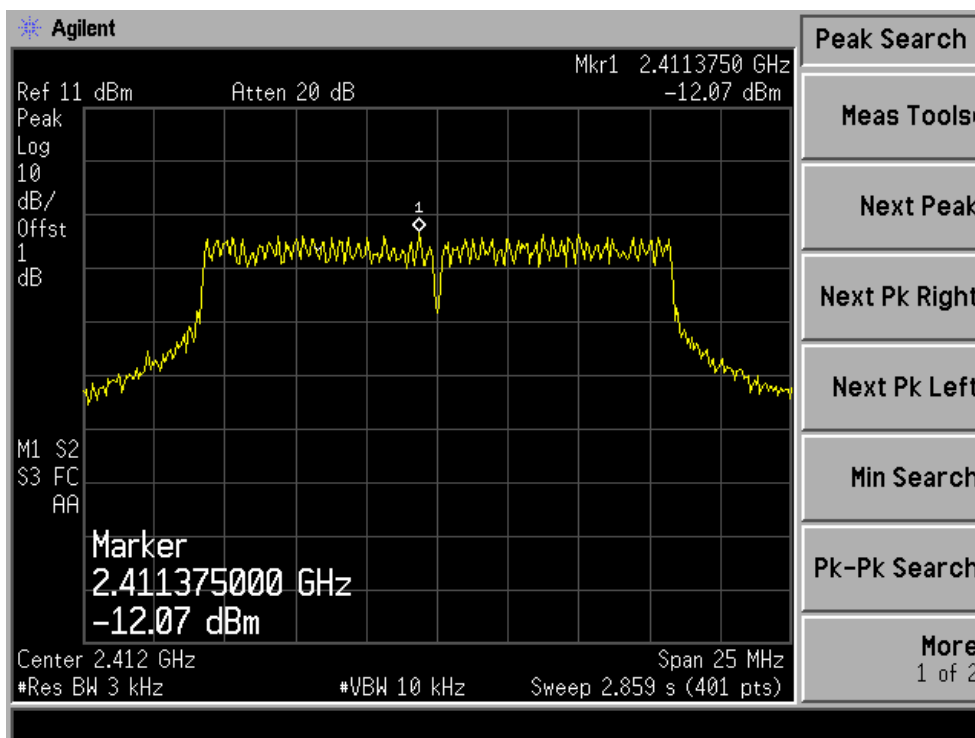

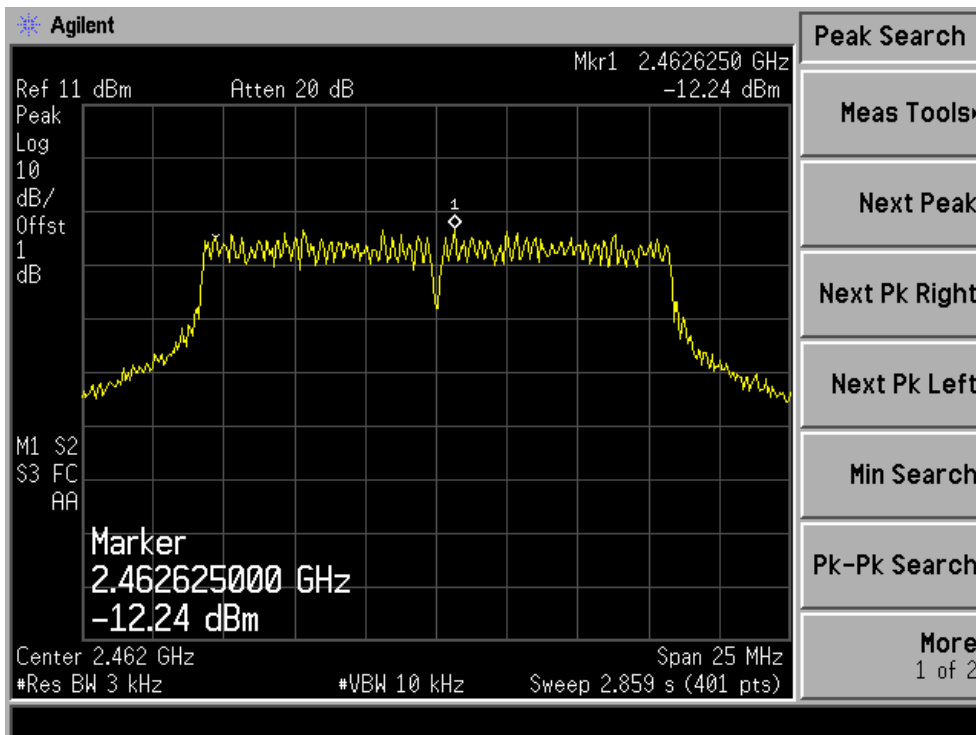
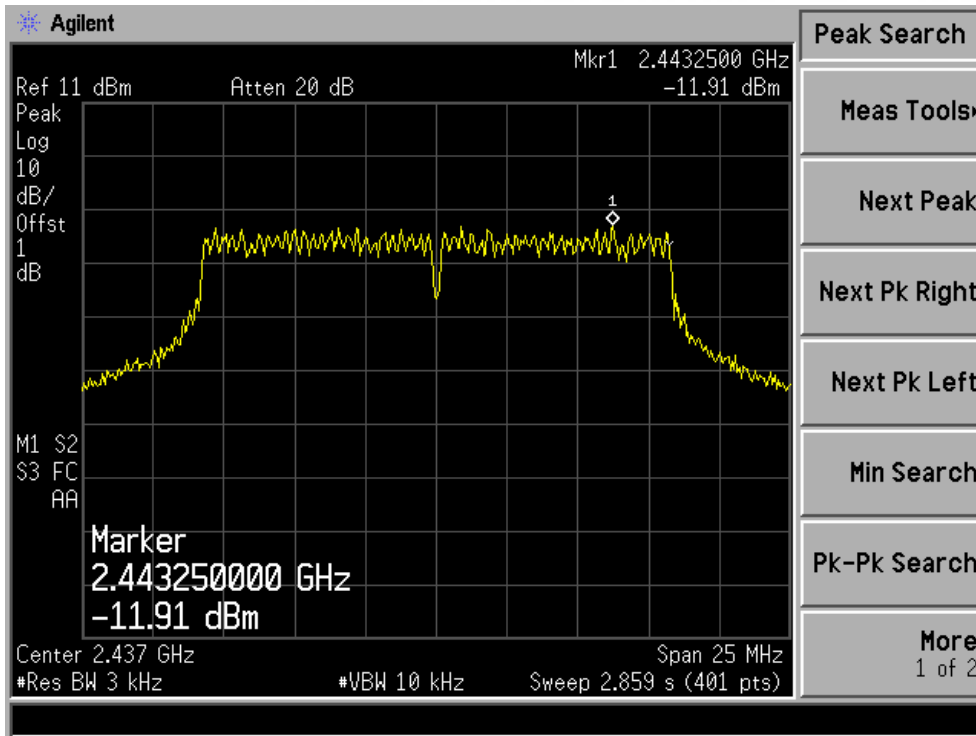

Spectrum Detector: PK Test Date : September 09, 2014
 Test By: SYP Temperature : 28°C
 Test Result: PASS Humidity : 55 %
 Operation Mode: 802.11 n HT20

Channel	Measurement Level (dBm)	Required Limit (dBm)	Result
1	-11.52	<8dBm	PASS
6	-11.40	<8dBm	PASS
11	-11.49	<8dBm	PASS

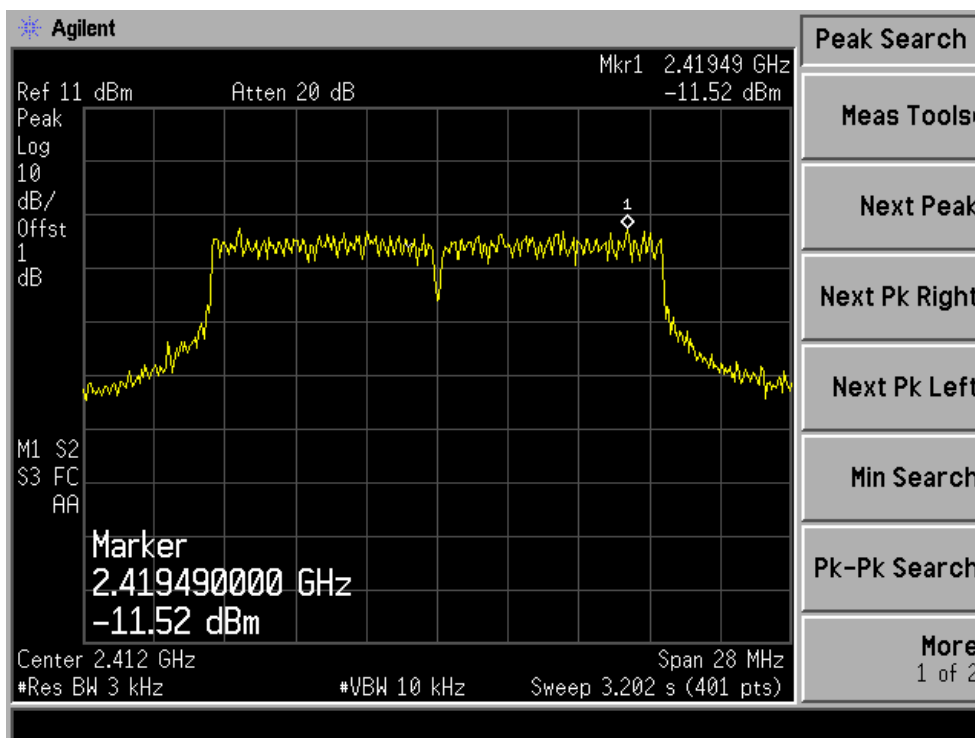

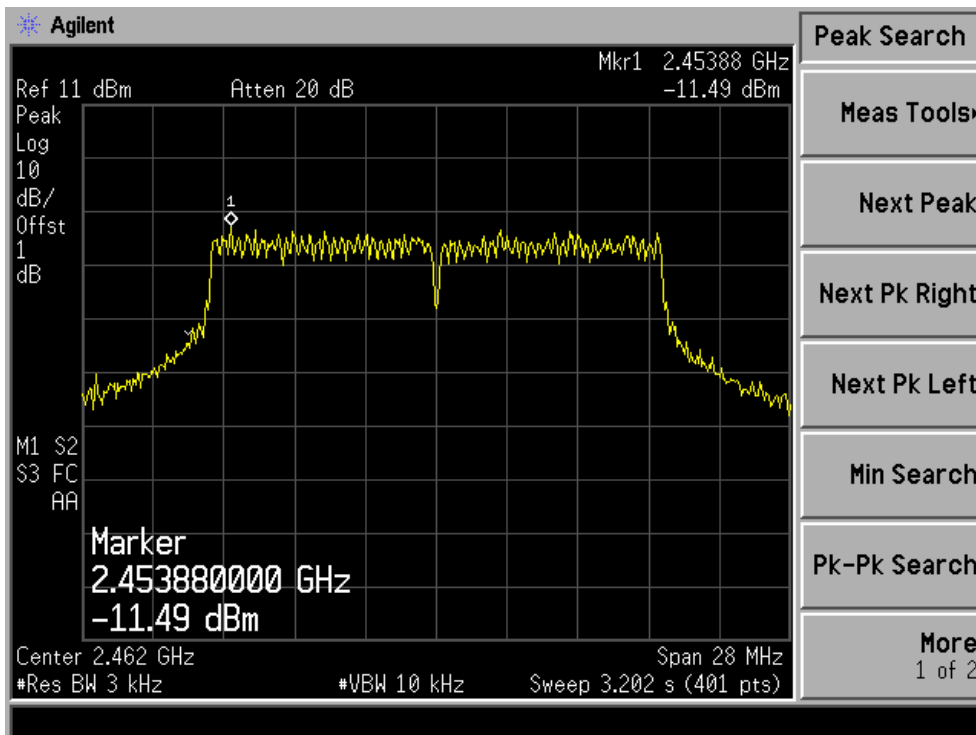
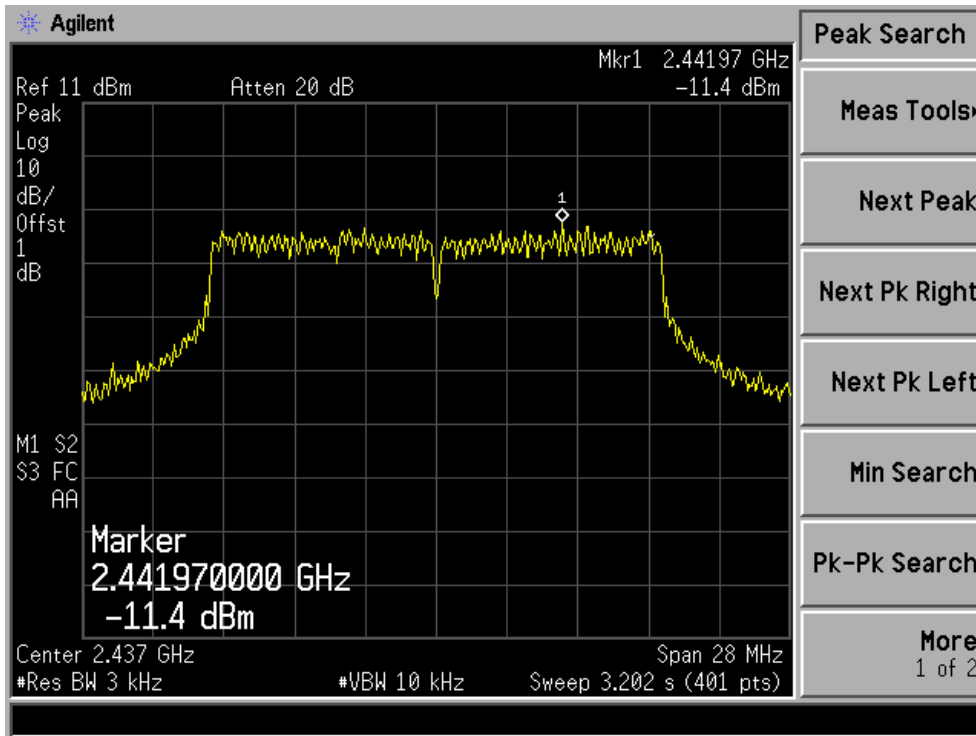

Spectrum Detector: PK Test Date : September 09, 2014
 Test By: SYP Temperature : 28°C
 Test Result: PASS Humidity : 55 %
 Operation Mode: 802.11 n HT40

Channel	Measurement Level (dBm)	Required Limit (dBm)	Result
3	-14.65	<8dBm	PASS
6	-15.15	<8dBm	PASS
9	-15.39	<8dBm	PASS

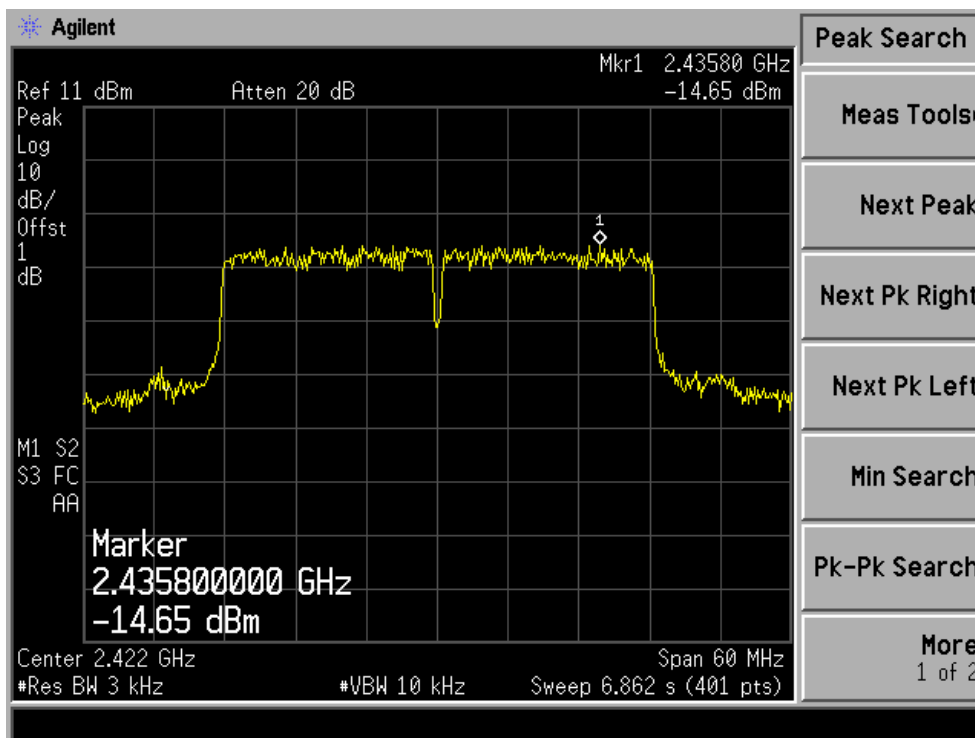

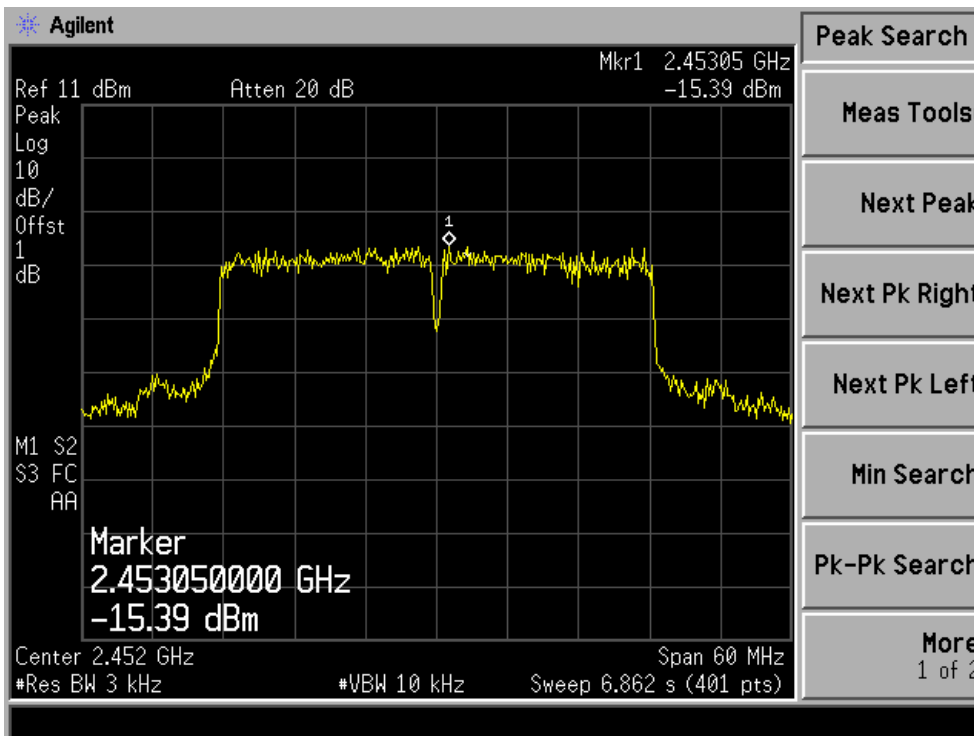
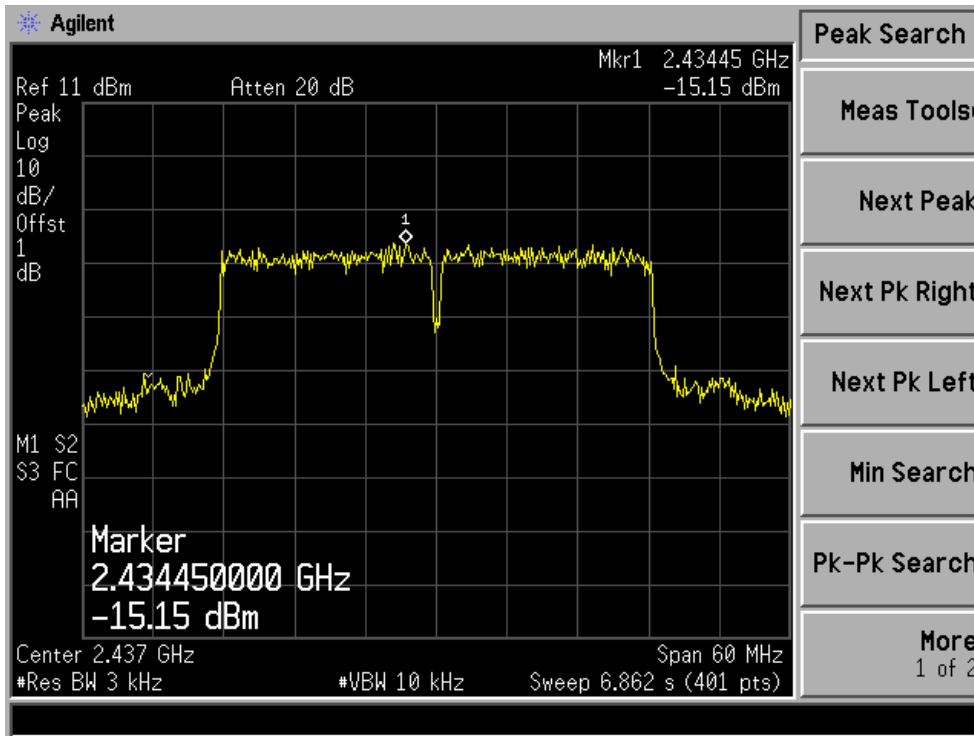

11. Antenna Port Emission

11.1 Test Equipment

EQUIPMENT TYPE	MFR	MODEL NUMBER	SERIAL NUMBER	LAST CAL.	CAL DUE.
Signal Analyzer	Agilent	N9010A	My53470879	05/17/2014	05/16/2015

11.2 Measuring Instruments and Setting

The following table is the setting of spectrum analyzer.

Spectrum analyzer	Setting
Attenuation	Auto
RB	100kHz
VB	300KHz
Detector	Peak
Trace	Max hold

11.3 Test Procedures

The conducted spurious emissions were measured conducted using a spectrum analyzer at low, Middle, and high channels, the limit was determined by attenuation 20dB of the RF peak power output.

11.4 Block Diagram of Test setup

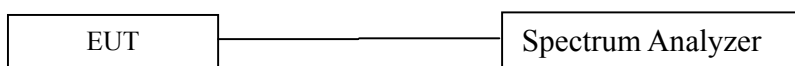

11.5 Test Result

PASS.

All the modulation modes were tested the data of the worst mode (TX 11b) are recorded in the following pages and the others modulation methods do not exceed the limits

802.11b Low Channel 1

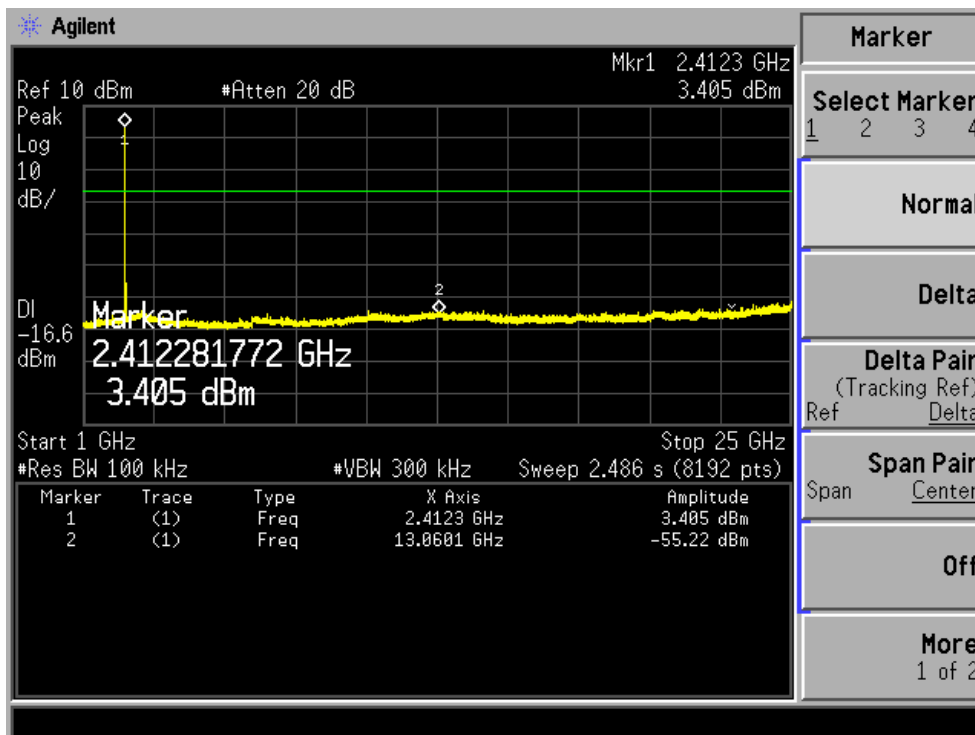
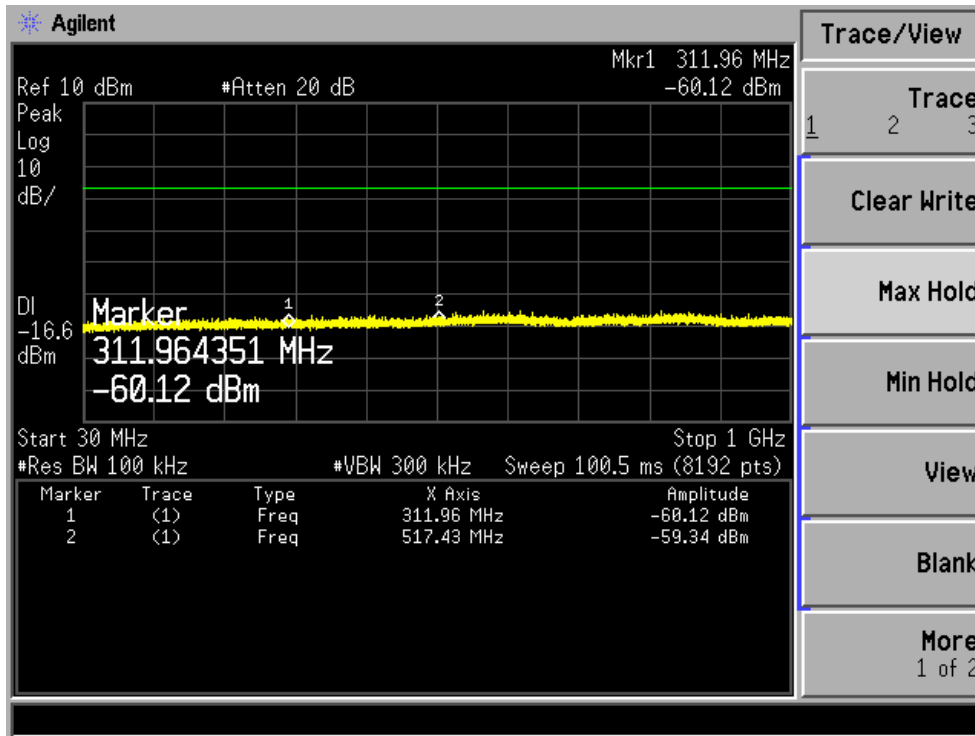

802.11b Mid Channel 6

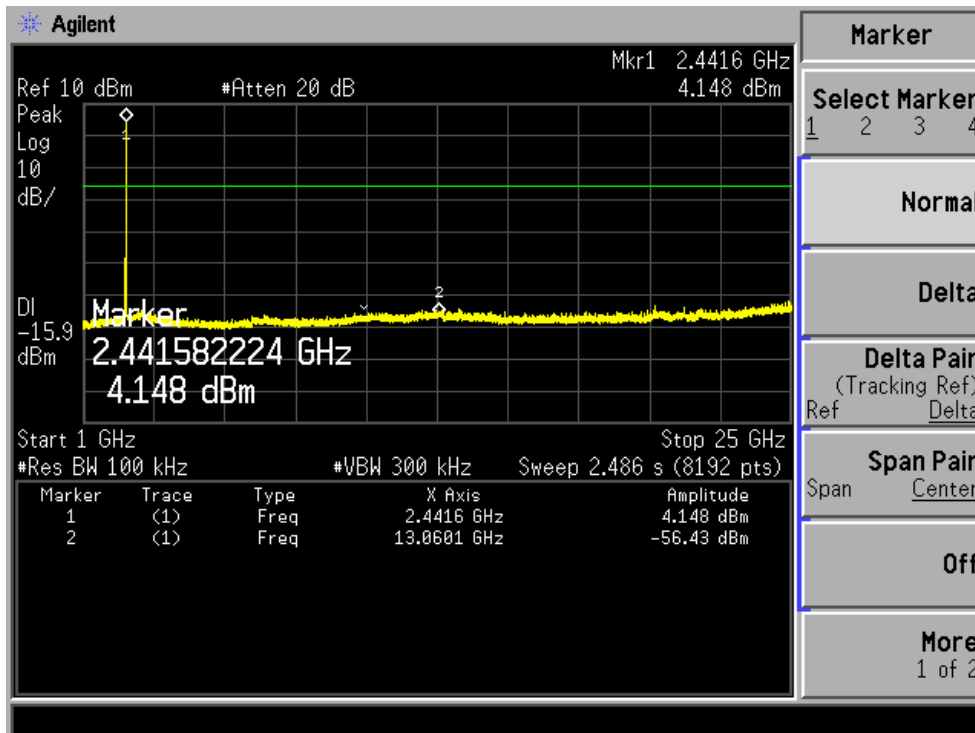
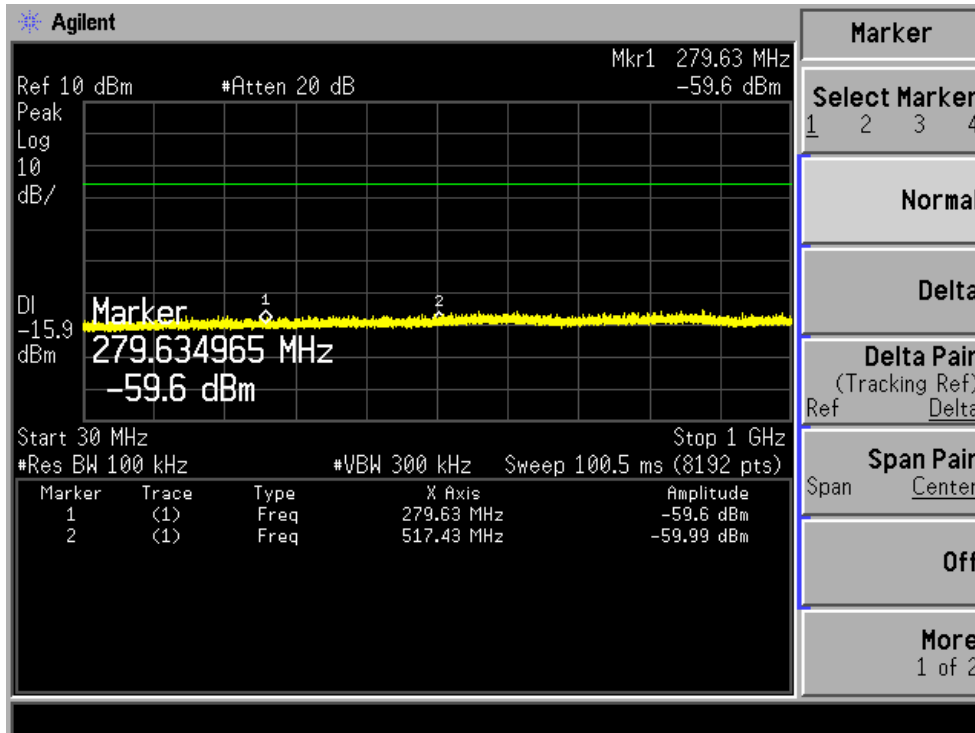

802.11b High Channel 11

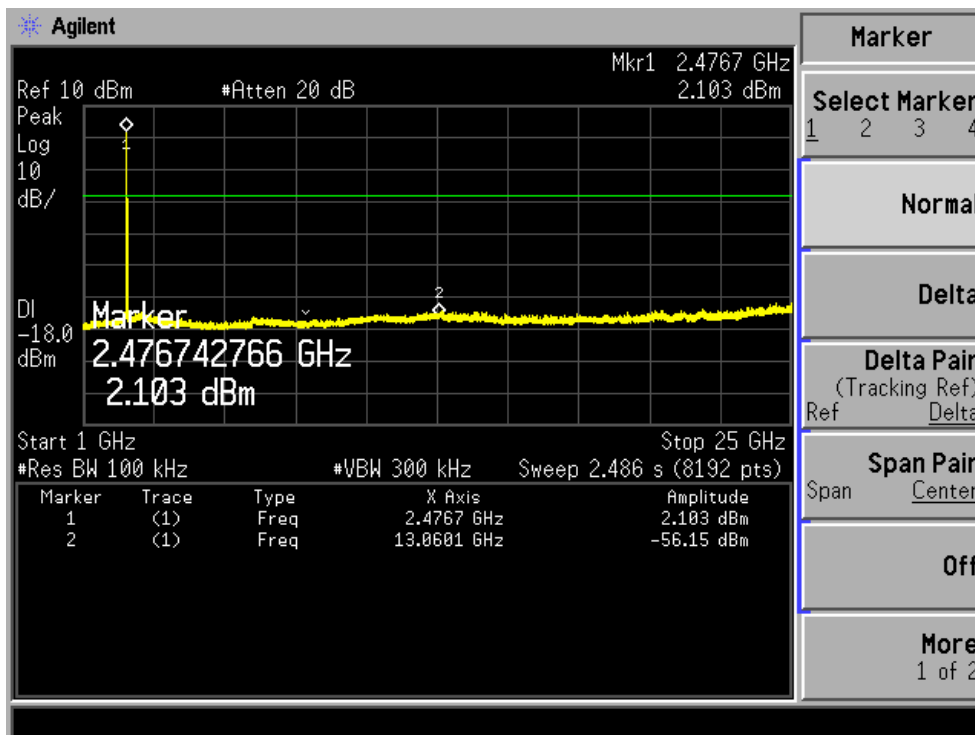
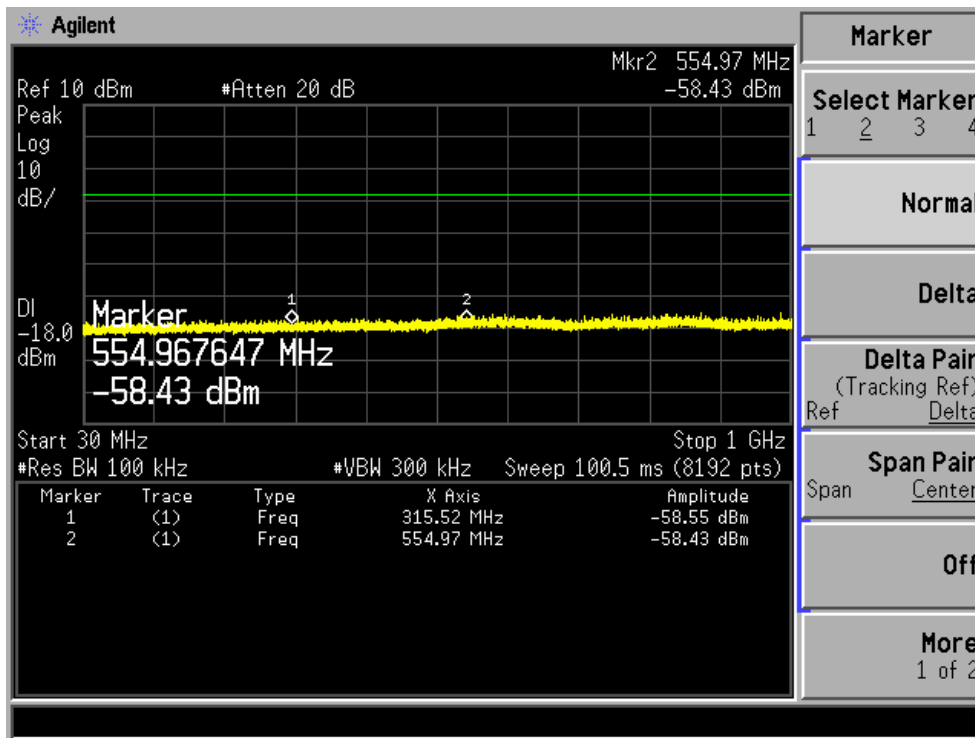

12. Antenna Application

12.1 Antenna Requirement

For intentional device, according to FCC 47 CFR Section 15.203, an intentional radiator shall be designed to ensure that no antenna other than that furnished by the responsible party shall be used with the device. And according to FCC 47 CFR Section 15.247 (b), if transmitting antennas of directional gain greater than 6dBi are used, the power shall be reduced by the amount in dB that the directional gain of the antenna exceeds 6dBi.

12.2 Result

The EUT'S antenna is integral antenna. The antenna's gain is 2 dBi and meets the requirement.