

**ELECTROMAGNETIC EMISSIONS COMPLIANCE REPORT
INTENTIONAL RADIATOR CERTIFICATION TO
FCC PART 15 SUBPART C REQUIREMENT**

OF

Android MID, nextbook

**MODEL No.: M8000ND, M8000NP, M8001ND, M8001NP,
M8002ND, M8002NP, M8003ND, M8003NP, M909ND, NX008HI8G, M909NP**

FCC ID: S7JNX008HI8G

REPORT NO: ES121112089E

ISSUE DATE: November 26, 2012

Prepared for

**SHENZHEN YIFANG DIGITAL TECHNOLOGY CO., LTD.
Building NO. 22, 23, Fifth Region. Baiwangxin Industrial Park, Songbai Rd.,
Nanshan, Shenzhen 518108, China**

Prepared by

SHENZHEN EMTEK CO., LTD.

**Bldg 69, Majialong Industry Zone, Nanshan District,
Shenzhen, Guangdong, China
TEL: 86-755-26954280
FAX: 86-755-26954282**

VERIFICATION OF COMPLIANCE

| | |
|----------------------|--|
| Applicant: | SHENZHEN YIFANG DIGITAL TECHNOLOGY CO., LTD. Building NO. 22, 23, Fifth Region. Baiwangxin Industrial Park, Songbai Rd., Nanshan, Shenzhen 518108, China |
| Manufacturer: | SHENZHEN YIFANG DIGITAL TECHNOLOGY CO., LTD. Building NO. 22, 23, Fifth Region. Baiwangxin Industrial Park, Songbai Rd., Nanshan, Shenzhen 518108, China |
| Product Description: | Android MID, nextbook |
| Model Number: | M8000ND, M8000NP, M8001ND, M8001NP, M8002ND, M8002NP, M8003ND, M8003NP, M909ND, NX008HI8G, M909NP |
| File Number: | ES121112089E |
| Date of Test: | November 13, 2012 to November 26, 2012 |

We hereby certify that:

The above equipment was tested by SHENZHEN EMTEK CO., LTD. The test data, data evaluation, test procedures, and equipment configurations shown in this report were made in accordance with the procedures given in ANSI C63.4 (2009) and the energy emitted by the sample EUT tested as described in this report is in compliance with conducted and radiated emission limits of FCC Rules Part 15.247.

The test results of this report relate only to the tested sample identified in this report.

Date of Test : November 13, 2012 to November 26, 2012

Prepared by :



Aaron Ma/Editor

Reviewer :



King Wang/Supervisor

Approve & Authorized Signer :



Lisa Wang/Manager

Table of Contents

| | |
|--|-----------|
| 1. GENERAL INFORMATION | 5 |
| 1.1 PRODUCT DESCRIPTION | 5 |
| 1.2 RELATED SUBMITTAL(S) / GRANT(S)..... | 5 |
| 1.3 TEST METHODOLOGY | 6 |
| 1.4 SPECIAL ACCESSORIES..... | 6 |
| 1.5 EQUIPMENT MODIFICATIONS | 6 |
| 1.6 TEST FACILITY | 6 |
| 2. SYSTEM TEST CONFIGURATION | 7 |
| 2.1 EUT CONFIGURATION | 7 |
| 2.2 EUT EXERCISE | 7 |
| 2.3 TEST PROCEDURE | 7 |
| 2.4 CONFIGURATION OF TESTED SYSTEM | 7 |
| 3. DESCRIPTION OF TEST MODES | 9 |
| 4. SUMMARY OF TEST RESULTS..... | 10 |
| 5. CONDUCTED EMISSIONS TEST | 11 |
| 5.1 MEASUREMENT PROCEDURE | 11 |
| 5.2 TEST SET-UP (BLOCK DIAGRAM OF CONFIGURATION) | 11 |
| 5.3 MEASUREMENT EQUIPMENT USED | 11 |
| 5.4 CONDUCTED EMISSION LIMIT | 11 |
| 5.5 MEASUREMENT RESULT..... | 12 |
| 5.6 CONDUCTED MEASUREMENT PHOTO..... | 14 |
| 6. RADIATED EMISSION TEST | 15 |
| 6.1 MEASUREMENT PROCEDURE | 15 |
| 6.2 TEST SET-UP (BLOCK DIAGRAM OF CONFIGURATION) | 15 |
| 6.3 MEASUREMENT EQUIPMENT USED | 16 |
| 6.4 RADIATED EMISSION LIMIT..... | 16 |
| 6.5 MEASUREMENT RESULT..... | 18 |
| 6.6 RADIATED MEASUREMENT PHOTOS..... | 45 |
| 7. OCCUPIED BANDWIDTH TEST | 47 |
| 7.1 MEASUREMENT PROCEDURE | 47 |
| 7.2 TEST SET-UP (BLOCK DIAGRAM OF CONFIGURATION) | 47 |
| 7.3 MEASUREMENT EQUIPMENT USED | 47 |
| 7.4 MEASUREMENT RESULTS..... | 47 |
| 8. MAXIMUM PEAK OUTPUT POWER TEST..... | 54 |
| 8.1 MEASUREMENT PROCEDURE | 54 |
| 8.2 TEST SET-UP (BLOCK DIAGRAM OF CONFIGURATION) | 54 |
| 8.3 MEASUREMENT EQUIPMENT USED | 54 |
| 8.4 PEAK POWER OUTPUT LIMIT | 54 |
| 8.5 MEASUREMENT RESULTS | 54 |
| 9. BAND EDGE TEST | 56 |
| 9.1 MEASUREMENT PROCEDURE | 56 |
| 9.2 TEST SET-UP (BLOCK DIAGRAM OF CONFIGURATION) | 56 |
| 9.3 MEASUREMENT EQUIPMENT USED | 56 |
| 9.4 MEASUREMENT RESULTS | 56 |
| 10. POWER DENSITY | 58 |
| 10.1 TEST EQUIPMENT | 58 |
| 10.2 MEASURING INSTRUMENTS AND SETTING..... | 58 |

| | | |
|------------|--|-----------|
| 10.3 | TEST PROCEDURES | 58 |
| 10.4 | BLOCK DIAGRAM OF TEST SETUP | 58 |
| 10.5 | LIMIT | 58 |
| 10.6 | TEST RESULT | 59 |
| 11. | ANTENNA PORT EMISSION | 65 |
| 11.1 | TEST EQUIPMENT | 65 |
| 11.2 | MEASURING INSTRUMENTS AND SETTING..... | 65 |
| 11.3 | TEST PROCEDURES | 65 |
| 11.4 | BLOCK DIAGRAM OF TEST SETUP | 65 |
| 11.5 | TEST RESULT | 65 |
| 12. | ANTENNA APPLICATION..... | 75 |
| 12.1 | ANTENNA REQUIREMENT..... | 75 |
| 12.2 | RESULT | 75 |

1. General Information

1.1 Product Description

A major technical descriptions of EUT is described as following:

- A). Standards: IEEE802.11b/g/n
- B). Operation Frequency: 802.11b/g/n: 2412-2462MHz;
- C). Modulation: OFDM with BPSK/QPSK/16QAM/64QAM for 802.11g/n,
 DSSS with DBPSK/DQPSK/CCK for 802.11b
- D). Number of Channel: 802.11b/g/n: 11Channels;
- E). Support Data Rate: 1, 2, 5.5, 11, 6, 9, 12, 24, 36, 48, 54, 65, 72.2Mbps
- F).Conducted Power: 10.61dBm(802.11b), 7.95dBm(802.11g), 7.84dBm(802.11n)
- G) Antenna Gain: 1dBi
- H). Antenna Type: PCB Antenna
- I). Power Supply: AC 120V, 60Hz with AC Adapter and DC 3.7V from Li-ion Battery
- J). Adapter 1: Model: DYS122-050200W-1
 Input: AC 100-240V, 50/60Hz 0.4A MAX
 Output: DC 5.3V, 2.0A
- K). Adapter 2: Model: BSC15-050200-UD
 Input: AC 100-240V, 50/60Hz 0.1A MAX
 Output: DC 5.3V, 2.0A

| Channel | Frequency (MHz) | Channel | Frequency (MHz) | Channel | Frequency (MHz) |
|---------|-----------------|---------|-----------------|---------|-----------------|
| 1 | 2412 | 5 | 2432 | 9 | 2452 |
| 2 | 2417 | 6 | 2437 | 10 | 2457 |
| 3 | 2422 | 7 | 2442 | 11 | 2462 |
| 4 | 2427 | 8 | 2447 | | |

Note:

1. This device is Android MID, nextbook included 802.11b, 802.11g, 802.11n 2.4GHz transceiver function.
2. Test of channel was included the lowest middle and highest frequency in lowest data rate and to perform the test, then record on this report.
3. This submissions include 2 AC adapters as Section 1.1 J)~K), we choose J) as the Full Tests and K) as the Limited Tests in Radiated Measurement below 1GHz only, then all measured results are recorded in this report.

1.2 Related Submittal(s) / Grant(s)

This submittal(s) (test report) is intended for FCC ID: S7JNX008HI8G filing to comply with Section 15.247 of the FCC Part 15, Subpart C Rules. The composite system is compliance with Subpart B is authorized under a DOC procedure.

1.3 Test Methodology

All the test program has follow FCC new test procedure KDB558074, Both conducted and radiated testing was performed according to the procedures in ANSI C63.10 (2009). Radiated testing was performed at an antenna to EUT distance 3 meters.

1.4 Special Accessories

Not available for this EUT intended for grant.

1.5 Equipment Modifications

Not available for this EUT intended for grant.

1.6 Test Facility

Site Description

EMC Lab.

: Accredited by CNAS, 2010.10.29

The certificate is valid until 2013.10.28

The Laboratory has been assessed and proved to be in compliance with CNAS/CL01: 2006(identical to ISO/IEC17025: 2005)

The Certificate Registration Number is L2291

Accredited by TUV Rheinland Shenzhen 2010.5.25

The Laboratory has been assessed according to the requirements ISO/IEC 17025

Accredited by FCC, October 28, 2010

The Certificate Registration Number is 406365.

Accredited by Industry Canada, March 05, 2010

The Certificate Registration Number is 46405-4480.

Name of Firm

: SHENZHEN EMTEK CO., LTD.

Site Location

: Bldg 69, Majialong Industry Zone,
Nanshan District, Shenzhen, Guangdong, China

2. System Test Configuration

2.1 EUT Configuration

The EUT configuration for testing is installed on RF field strength measurement to meet the Commissions requirement and operating in a manner which intends to maximize its emission characteristics in a continuous normal application.

2.2 EUT Exercise

The Transmitter was operated in the normal operating mode. the Tx frequency was fixed which was for the purpose of the measurements.

2.3 Test Procedure

2.3.1 Conducted Emissions

The EUT is a placed on as turn table which is 0.8 m above ground plane. According to the requirements in Section 13.1.4.1 of ANSI C63.4-2009 Conducted emissions from the EUT measured in the frequency range between 0.15 MHz and 30 MHz using CISPR Quasi-Peak and average detector mode.

2.3.2 Radiated Emissions

The EUT is a placed on as turn table which is 0.8 m above ground plane. The turn table shall rotate 360 degrees to determine the position of maximum emission level. EUT is set 3m away from the receiving antenna which varied from 1m to 4m to find out the highest emission. And also, each emission was to be maximized by changing the polarization of receiving antenna both horizontal and vertical. In order to find out the max. emission, the relative positions of this hand-held transmitter(EUT) was rotated through three orthogonal axes according to the requirements in Section 13.1.4.1 of ANSI C63.4-2009.

2.4 Configuration of Tested System

Fig. 2-1 Configuration of Tested System

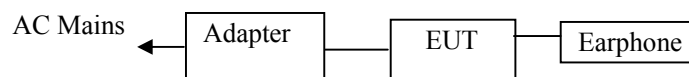

Table 2-1 Equipment Used in Tested System

| Item | Equipment | Mfr/Brand | Model/Type No. | FCC ID | Series No. | Note |
|------|--------------------------|-----------|----------------|--------------|------------|------|
| 1. | Android MID, nextbook | N/A | M8000ND | S7JNX008HI8G | N/A | EUT |
| 2. | Earphone | Yifang | N/A | N/A | N/A | |

Note:

- (1) Unless otherwise denoted as EUT in 『Remark』 column, device(s) used in tested system is a support equipment.

3. Description of Test Modes

The Transmitter of EUT is an Android MID, nextbookand powered by host equipment; these is Digital Transmission system (DTS) and have modulation OFDM, DSSS, DBPSK, DQPSK, CCK, 16QAM, 64QAM. According exploratory test, EUT will have maximum output power in those data rate(802.11b: 1 Mbps; 802.11g: 6 Mbps; 802.11n: MCS0), so those data rate were used for all test.

The equipment enables high-speed access without wires to network assets. This adapter uses the IEEE 802.11 protocol to enable wireless communications between the host and Wireless router.

For 802.11b/g/n:

1. For lowest channel : 2412MHz (Channel 1)
2. For middle channel : 2437MHz (Channel 6)
3. For highest channel: 2462MHz (Channel 11)

4. Summary of Test Results

| FCC Rules | Description Of Test | Result |
|---------------------|-----------------------------|---------------|
| §15.247(a)(2) | 6dB bandwidth | Pass |
| §15.247(b)(3) | Max Peak output Power test | Pass |
| §15.247(e) | Power density | Pass |
| §15.247(d) | Band edge test | Pass |
| §15.207 | AC Power Conducted Emission | Pass |
| §15.247(d), §15.209 | Radiated Emission | Pass |
| §15.247(d) | Antenna Port Emission | Pass |
| §15.247(b)&§15.203 | Antenna Application | Pass |

5. Conducted Emissions Test

5.1 Measurement Procedure

1. The EUT was placed on a table which is 0.8m above ground plane.
2. Maximum procedure was performed on the six highest emissions to ensure EUT compliance.
3. Repeat above procedures until all frequency measured were complete.

5.2 Test SET-UP (Block Diagram of Configuration)

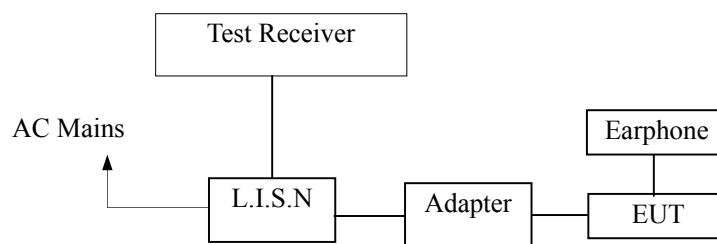

5.3 Measurement Equipment Used

| Conducted Emission Test Site | | | | | |
|------------------------------|-----------------|--------------|---------------|------------|------------|
| EQUIPMENT TYPE | MFR | MODEL NUMBER | SERIAL NUMBER | LAST CAL. | CAL DUE. |
| Test Receiver | Rohde & Schwarz | ESCS30 | 828985/018 | 05/29/2012 | 05/28/2013 |
| L.I.S.N. | Schwarzbeck | NNLK8129 | 8129203 | 05/29/2012 | 05/28/2013 |
| 50Ω Coaxial Switch | Anritsu | MP59B | M20531 | N/A | N/A |
| Pulse Limiter | Rohde & Schwarz | ESH3-Z2 | 100006 | 05/29/2012 | 05/28/2013 |
| Voltage Probe | Rohde & Schwarz | TK9416 | N/A | 05/29/2012 | 05/28/2013 |
| I.S.N | Rohde & Schwarz | ENY22 | 1109.9508.02 | 05/29/2012 | 05/28/2013 |

5.4 Conducted Emission Limit

Conducted Emission

| Frequency(MHz) | Quasi-peak | Average |
|----------------|------------|---------|
| 0.15-0.5 | 66-56 | 56-46 |
| 0.5-5.0 | 56 | 46 |
| 5.0-30.0 | 60 | 50 |

- Note:**
1. The lower limit shall apply at the transition frequencies
 2. The limit decreases in line with the logarithm of the frequency in the range of 0.15 to 0.50MHz.

5.5 Measurement Result

We take 802.11b/g/n mode to test, and the worst test data as following and all modulation methods do not exceed the above mentioned limits.

| | | | |
|---------------------|-------------------|--------------|---------|
| Date of Test: | November 20, 2012 | Temperature: | 22°C |
| Frequency Detector: | 0.15~30MHz | Humidity: | 50% |
| Test Result: | PASS | Test Mode: | TX Mode |
| Note: | Adapter 1 | | |

| Test Line | Frequency MHz | Emission Level QP dB(μV) | Emission Level AV dB(μV) | Limits QP dB(μV) | Limits AV dB(μV) | Over QP dB(μV) | Over AV dB(μV) |
|-----------|---------------|--------------------------|--------------------------|------------------|------------------|----------------|----------------|
| Line | 0.16 | 52.46 | 40.22 | 65.46 | 55.46 | -13.00 | -15.24 |
| | 0.20 | 45.78 | 33.35 | 63.61 | 53.61 | -17.83 | -20.26 |
| | 0.29 | 41.54 | 29.67 | 60.52 | 50.52 | -18.98 | -20.85 |
| | 1.59 | 41.83 | 30.79 | 56.00 | 46.00 | -14.17 | -15.21 |
| | 2.61 | 39.65 | 28.61 | 56.00 | 46.00 | -16.35 | -17.39 |
| | 9.95 | 38.49 | 29.89 | 60.00 | 50.00 | -21.51 | -20.11 |
| Neutral | 0.16 | 53.13 | 39.45 | 65.46 | 55.46 | -12.33 | -16.01 |
| | 0.20 | 46.14 | 33.78 | 63.61 | 53.61 | -17.47 | -19.83 |
| | 0.24 | 41.95 | 28.74 | 62.10 | 52.10 | -20.15 | -23.36 |
| | 1.83 | 39.37 | 32.10 | 56.00 | 46.00 | -16.63 | -13.90 |
| | 2.52 | 37.56 | 28.85 | 56.00 | 46.00 | -18.44 | -17.15 |
| | 9.63 | 37.00 | 27.74 | 60.00 | 50.00 | -23.00 | -22.26 |

Date of Test: November 20, 2012 Temperature: 22°C
 Frequency Detector: 0.15~30MHz Humidity: 50%
 Test Result: PASS Test Mode: TX Mode
 Note: Adapter 2

| Test Line | Frequency MHz | Emission Level QP dB(μV) | Emission Level AV dB(μV) | Limits QP dB(μV) | Limits AV dB(μV) | Over QP dB(μV) | Over AV dB(μV) |
|-----------|---------------|--------------------------|--------------------------|------------------|------------------|----------------|----------------|
| Line | 0.16 | 56.06 | 43.50 | 65.46 | 55.46 | -9.40 | -11.96 |
| | 0.20 | 51.34 | 37.13 | 63.61 | 53.61 | -12.27 | -16.48 |
| | 0.29 | 47.00 | 33.66 | 60.52 | 50.52 | -13.52 | -16.86 |
| | 0.45 | 46.65 | 39.69 | 56.88 | 46.88 | -10.23 | -7.19 |
| | 0.57 | 42.29 | 36.11 | 56.00 | 46.00 | -13.71 | -9.89 |
| | 2.37 | 40.43 | 33.83 | 56.00 | 46.00 | -15.57 | -12.17 |
| Neutral | 0.16 | 56.75 | 42.39 | 65.46 | 55.46 | -8.71 | -13.07 |
| | 0.20 | 50.74 | 38.04 | 63.61 | 53.61 | -12.87 | -15.57 |
| | 0.25 | 47.79 | 35.07 | 61.76 | 51.76 | -13.97 | -16.69 |
| | 0.33 | 47.54 | 37.05 | 59.45 | 49.45 | -11.91 | -12.40 |
| | 1.84 | 42.28 | 32.97 | 56.00 | 46.00 | -13.72 | -13.03 |
| | 2.41 | 42.83 | 32.02 | 56.00 | 46.00 | -13.17 | -13.98 |

5.6 Conducted Measurement Photo



6. Radiated Emission Test

6.1 Measurement Procedure

1. The EUT was placed on a turntable which is 0.8m above ground plane.
2. Maximum procedure was performed on the six highest emissions to ensure EUT compliance.
3. And also, each emission was to be maximized by changing the polarization of receiving antenna both horizontal and vertical.
4. Repeat above procedures until all frequency measured were complete.

For emissions measurement set the bandwidth of the Spectrum's RBW at 1MHz above 1GHz and RBW 100KHz below 1GHz .

6.2 Test SET-UP (Block Diagram of Configuration)

(A) Radiated Emission Test Set-Up, Frequency Below 30MHz

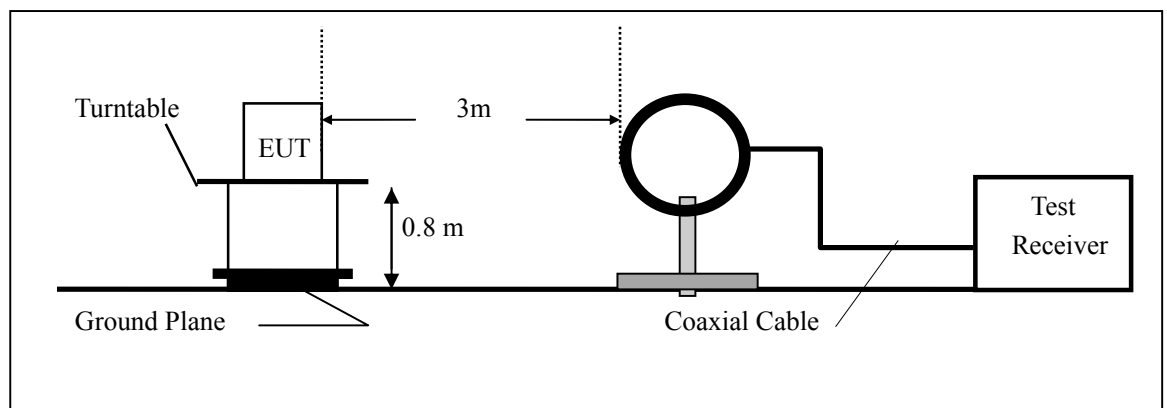

(B) Radiated Emission Test Set-Up, Frequency Below 1000MHz

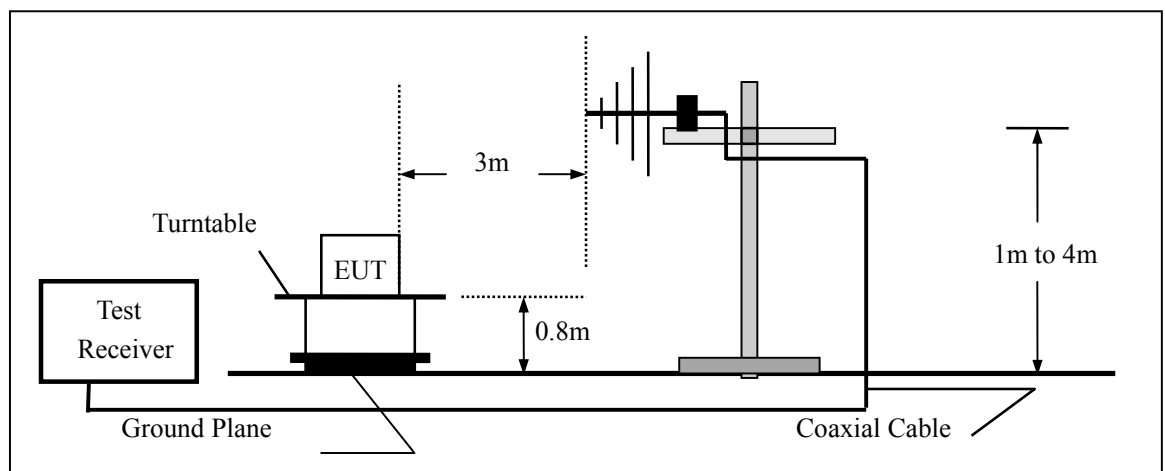

(C) Radiated Emission Test Set-Up, Frequency above 1000MHz

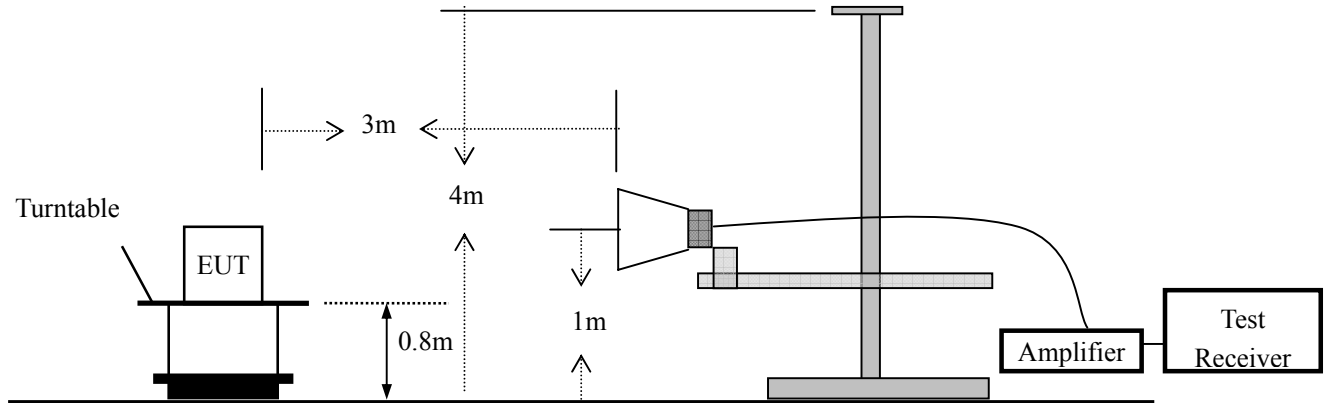

6.3 Measurement Equipment Used

| EQUIPMENT TYPE | MFR | MODEL NUMBER | SERIAL NUMBER | LAST CAL. | CAL DUE. |
|-------------------|-----------------|--------------|---------------|--------------|------------|
| EMI Test Receiver | Rohde & Schwarz | ESU | 1302.6005.26 | May 29, 2012 | 05/28/2013 |
| Pre-Amplifier | HP | 8447D | 2944A07999 | May 29, 2012 | 05/28/2013 |
| Bilog Antenna | Schwarzbeck | VULB9163 | 142 | May 29, 2012 | 05/28/2013 |
| Loop Antenna | ARA | PLA-1030/B | 1029 | May 29, 2012 | 05/28/2013 |
| Horn Antenna | Schwarzbeck | BBHA 9170 | BBHA9170399 | May 29, 2012 | 05/28/2013 |
| Horn Antenna | Schwarzbeck | BBHA 9120 | D143 | May 29, 2012 | 05/28/2013 |
| Cable | Schwarzbeck | AK9513 | ACRX1 | May 29, 2012 | 05/28/2013 |
| Cable | Rosenberger | N/A | FP2RX2 | May 29, 2012 | 05/28/2013 |
| Cable | Schwarzbeck | AK9513 | CRPX1 | May 29, 2012 | 05/28/2013 |
| Cable | Schwarzbeck | AK9513 | CRRX2 | May 29, 2012 | 05/28/2013 |

6.4 Radiated Emission Limit

The emissions from an intentional radiator shall not exceed the field strength levels specified in the following table 15.209(a):

| Frequencies (MHz) | Field Strength (micorvolts/meter) | Measurement Distance (meters) |
|-------------------|-----------------------------------|-------------------------------|
| 0.009~0.490 | 2400/F(KHz) | 300 |
| 0.490~1.705 | 24000/F(KHz) | 30 |
| 1.705~30.0 | 30 | 30 |
| 30~88 | 100 | 3 |
| 88~216 | 150 | 3 |
| 216~960 | 200 | 3 |
| Above 960 | 500 | 3 |

15.205 Restricted bands of operation

| MHz | MHz | MHz | GHz |
|----------------------------|-----------------------|-----------------|------------------|
| 0.090 - 0.110 | 16.42 - 16.423 | 399.9 - 410 | 4.5 - 5.15 |
| ¹ 0.495 - 0.505 | 16.69475 - 16.69525 | 608 - 614 | 5.35 - 5.46 |
| 2.1735 - 2.1905 | 16.80425 - 16.80475 | 960 - 1240 | 7.25 - 7.75 |
| 4.125 - 4.128 | 25.5 - 25.67 | 1300 - 1427 | 8.025 - 8.5 |
| 4.17725 - 4.17775 | 37.5 - 38.25 | 1435 - 1626.5 | 9.0 - 9.2 |
| 4.20725 - 4.20775 | 73 - 74.6 | 1645.5 - 1646.5 | 9.3 - 9.5 |
| 6.215 - 6.218 | 74.8 - 75.2 | 1660 - 1710 | 10.6 - 12.7 |
| 6.26775 - 6.26825 | 108 - 121.94 | 1718.8 - 1722.2 | 13.25 - 13.4 |
| 6.31175 - 6.31225 | 123 - 138 | 2200 - 2300 | 14.47 - 14.5 |
| 8.291 - 8.294 | 149.9 - 150.05 | 2310 - 2390 | 15.35 - 16.2 |
| 8.362 - 8.366 | 156.52475 - 156.52525 | 2483.5 - 2500 | 17.7 - 21.4 |
| 8.37625 - 8.38675 | 156.7 - 156.9 | 2690 - 2900 | 22.01 - 23.12 |
| 8.41425 - 8.41475 | 162.0125 - 167.17 | 3260 - 3267 | 23.6 - 24.0 |
| 12.29 - 12.293 | 167.72 - 173.2 | 3332 - 3339 | 31.2 - 31.8 |
| 12.51975 - 12.52025 | 240 - 285 | 3345.8 - 3358 | 36.43 - 36.5 |
| 12.57675 - 12.57725 | 322 - 335.4 | 3600 - 4400 | (²) |

- Remark: 1. Emission level in dBuV/m=20 log (uV/m)
 2. Measurement was performed at an antenna to the closed point of EUT distance of meters.
 3. Only spurious frequency is permitted to locate within the Restricted Bands specified in provision of § 15.205, and the emissions located in restricted bands also comply with 15.209 limit.

Operation Mode: 802.11b TX Channel 6 Test Date : November 20, 2012
 Frequency Range: 30~1000MHz Temperature : 28°C
 Test Result: PASS Humidity : 65 %
 Measured Distance: 3m Test By: WOLF
 Note: Adapter 1

| Freq. (MHz) | Ant.Pol. H/V | Emission Level (dBuV/m) | Limit 3m (dBuV/m) | Over (dB) | Note |
|----------------|-----------------|----------------------------|----------------------|--------------|------|
| 37.42 | V | 20.27 | 40.00 | -19.73 | PK |
| 60.79 | V | 21.89 | 40.00 | -18.11 | PK |
| 80.19 | V | 29.57 | 40.00 | -10.43 | PK |
| 101.16 | V | 32.09 | 43.50 | -11.41 | PK |
| 182.33 | V | 20.21 | 43.50 | -23.29 | PK |
| 242.68 | V | 20.44 | 46.00 | -25.56 | PK |
| 55.27 | H | 23.25 | 40.00 | -16.75 | PK |
| 77.88 | H | 32.90 | 40.00 | -7.10 | PK |
| 110.38 | H | 20.49 | 43.50 | -23.01 | PK |
| 187.35 | H | 24.59 | 43.50 | -18.91 | PK |
| 252.29 | H | 32.08 | 46.00 | -13.92 | PK |
| 377.92 | H | 23.64 | 46.00 | -22.36 | PK |

- Note:**
- (1) All Readings are Peak Value.
 - (2) Emission Level= Reading Level+Probe Factor +Cable Loss.
 - (3) The average measurement was not performed when the peak measured data under the limit of average detection.
 - (4) EUT stood on the table position is the worst case result in the report.

Operation Mode: 802.11b TX Channel 11 Test Date : November 20, 2012
 Frequency Range: 30~1000MHz Temperature : 28°C
 Test Result: PASS Humidity : 65 %
 Measured Distance: 3m Test By: WOLF
 Note: Adapter 1

| Freq. (MHz) | Ant.Pol. H/V | Emission Level (dBuV/m) | Limit 3m (dBuV/m) | Over (dB) | Note |
|----------------|-----------------|----------------------------|----------------------|--------------|------|
| 36.62 | V | 21.45 | 40.00 | -18.55 | PK |
| 59.29 | V | 21.44 | 40.00 | -18.56 | PK |
| 77.59 | V | 29.57 | 40.00 | -10.43 | PK |
| 98.16 | V | 27.26 | 43.50 | -16.24 | PK |
| 179.88 | V | 24.31 | 43.50 | -19.19 | PK |
| 241.32 | V | 23.36 | 46.00 | -22.64 | PK |
| 59.27 | H | 23.25 | 40.00 | -16.75 | PK |
| 79.38 | H | 35.60 | 40.00 | -4.40 | PK |
| 112.98 | H | 20.43 | 43.50 | -23.07 | PK |
| 190.35 | H | 30.29 | 43.50 | -13.21 | PK |
| 254.74 | H | 34.44 | 46.00 | -11.56 | PK |
| 379.28 | H | 26.20 | 46.00 | -19.80 | PK |

- Note:**
- (1) All Readings are Peak Value.
 - (2) Emission Level= Reading Level+Probe Factor +Cable Loss.
 - (3) The average measurement was not performed when the peak measured data under the limit of average detection.
 - (4) EUT stood on the table position is the worst case result in the report.

Operation Mode: 802.11g TX Channel 1 Test Date : November 20, 2012
 Frequency Range: 30~1000MHz Temperature : 28°C
 Test Result: PASS Humidity : 65 %
 Measured Distance: 3m Test By: WOLF
 Note: Adapter 1

| Freq. (MHz) | Ant.Pol. H/V | Emission Level (dBuV/m) | Limit 3m (dBuV/m) | Over (dB) | Note |
|----------------|-----------------|----------------------------|----------------------|--------------|------|
| 34.66 | V | 29.62 | 40.00 | -10.38 | PK |
| 71.97 | V | 31.04 | 40.00 | -8.96 | PK |
| 107.72 | V | 33.15 | 43.50 | -10.35 | PK |
| 162.13 | V | 27.19 | 43.50 | -16.31 | PK |
| 179.23 | V | 36.47 | 43.50 | -7.03 | PK |
| 252.29 | V | 30.60 | 46.00 | -15.40 | PK |
| 71.97 | H | 31.06 | 40.00 | -8.94 | PK |
| 107.72 | H | 34.42 | 43.50 | -9.08 | PK |
| 124.82 | H | 32.21 | 43.50 | -11.29 | PK |
| 162.13 | H | 31.08 | 43.50 | -12.42 | PK |
| 179.23 | H | 39.41 | 43.50 | -4.09 | PK |
| 252.29 | H | 32.70 | 46.00 | -13.30 | PK |

- Note:**
- (1) All Readings are Peak Value.
 - (2) Emission Level= Reading Level+Probe Factor +Cable Loss.
 - (3) The average measurement was not performed when the peak measured data under the limit of average detection.
 - (4) EUT stood on the table position is the worst case result in the report.

Operation Mode: 802.11g TX Channel 6 Test Date : November 20, 2012
 Frequency Range: 30~1000MHz Temperature : 28°C
 Test Result: PASS Humidity : 65%
 Measured Distance: 3m Test By: WOLF
 Note: Adapter 1

| Freq. (MHz) | Ant.Pol. H/V | Emission Level (dBuV/m) | Limit 3m (dBuV/m) | Over (dB) | Note |
|----------------|-----------------|----------------------------|----------------------|--------------|------|
| 35.86 | V | 29.67 | 40.00 | -10.33 | PK |
| 73.22 | V | 31.29 | 40.00 | -8.71 | PK |
| 111.28 | V | 35.60 | 43.50 | -7.90 | PK |
| 166.45 | V | 30.49 | 43.50 | -13.01 | PK |
| 177.67 | V | 35.38 | 43.50 | -8.12 | PK |
| 245.79 | V | 30.29 | 46.00 | -15.71 | PK |
| 72.37 | H | 33.42 | 40.00 | -6.58 | PK |
| 108.97 | H | 34.42 | 43.50 | -9.08 | PK |
| 121.26 | H | 32.37 | 43.50 | -11.13 | PK |
| 157.81 | H | 31.38 | 43.50 | -12.12 | PK |
| 177.67 | H | 41.47 | 43.50 | -2.03 | PK |
| 245.79 | H | 32.14 | 46.00 | -13.86 | PK |

- Note:**
- (1) All Readings are Peak Value.
 - (2) Emission Level= Reading Level+Probe Factor +Cable Loss.
 - (3) The average measurement was not performed when the peak measured data under the limit of average detection.
 - (4) EUT stood on the table position is the worst case result in the report.

Operation Mode: 802.11g TX Channel 11 Test Date : November 20, 2012
 Frequency Range: 30~1000MHz Temperature : 28°C
 Test Result: PASS Humidity : 65 %
 Measured Distance: 3m Test By: WOLF
 Note: Adapter 1

| Freq. (MHz) | Ant.Pol. H/V | Emission Level (dBuV/m) | Limit 3m (dBuV/m) | Over (dB) | Note |
|----------------|-----------------|----------------------------|----------------------|--------------|------|
| 35.06 | V | 30.85 | 40.00 | -9.15 | PK |
| 71.72 | V | 30.84 | 40.00 | -9.16 | PK |
| 108.68 | V | 35.60 | 43.50 | -7.90 | PK |
| 163.45 | V | 31.45 | 43.50 | -12.05 | PK |
| 175.22 | V | 39.48 | 43.50 | -4.02 | PK |
| 244.43 | V | 33.21 | 46.00 | -12.79 | PK |
| 76.37 | H | 33.42 | 40.00 | -6.58 | PK |
| 110.47 | H | 37.12 | 43.50 | -6.38 | PK |
| 123.86 | H | 32.31 | 43.50 | -11.19 | PK |
| 160.81 | H | 37.08 | 43.50 | -6.42 | PK |
| 180.12 | H | 40.93 | 43.50 | -2.57 | PK |
| 247.15 | H | 34.70 | 46.00 | -11.30 | PK |

- Note:**
- (1) All Readings are Peak Value.
 - (2) Emission Level= Reading Level+Probe Factor +Cable Loss.
 - (3) The average measurement was not performed when the peak measured data under the limit of average detection.
 - (4) EUT stood on the table position is the worst case result in the report.

Operation Mode: 802.11n TX Channel 1 Test Date : November 20, 2012
 Frequency Range: 30~1000MHz Temperature : 28°C
 Test Result: PASS Humidity : 65 %
 Measured Distance: 3m Test By: WOLF
 Note: Adapter 1

| Freq. (MHz) | Ant.Pol. H/V | Emission Level (dBuV/m) | Limit 3m (dBuV/m) | Over (dB) | Note |
|----------------|-----------------|----------------------------|----------------------|--------------|------|
| 36.22 | V | 19.84 | 40.00 | -20.16 | PK |
| 54.87 | V | 21.92 | 40.00 | -18.08 | PK |
| 78.19 | V | 26.84 | 40.00 | -13.16 | PK |
| 96.84 | V | 22.13 | 43.50 | -21.37 | PK |
| 185.45 | V | 21.48 | 43.50 | -22.02 | PK |
| 239.86 | V | 21.04 | 46.00 | -24.96 | PK |
| 54.87 | H | 20.32 | 40.00 | -19.68 | PK |
| 76.63 | H | 32.43 | 40.00 | -7.57 | PK |
| 109.28 | H | 21.01 | 43.50 | -22.49 | PK |
| 183.89 | H | 24.81 | 43.50 | -18.69 | PK |
| 253.85 | H | 29.34 | 46.00 | -16.66 | PK |
| 636.25 | H | 24.70 | 46.00 | -21.30 | PK |

- Note:**
- (1) All Readings are Peak Value.
 - (2) Emission Level= Reading Level+Probe Factor +Cable Loss.
 - (3) The average measurement was not performed when the peak measured data under the limit of average detection.
 - (4) EUT stood on the table position is the worst case result in the report.

Operation Mode: 802.11n TX Channel 6 Test Date : November 20, 2012
 Frequency Range: 30~1000MHz Temperature : 28°C
 Test Result: PASS Humidity : 65 %
 Measured Distance: 3m Test By: WOLF
 Note: Adapter 1

| Freq. (MHz) | Ant.Pol. H/V | Emission Level (dBuV/m) | Limit 3m (dBuV/m) | Over (dB) | Note |
|----------------|-----------------|----------------------------|----------------------|--------------|------|
| 37.42 | V | 19.89 | 40.00 | -20.11 | PK |
| 56.12 | V | 22.17 | 40.00 | -17.83 | PK |
| 81.75 | V | 29.29 | 40.00 | -10.71 | PK |
| 101.16 | V | 31.57 | 43.50 | -11.93 | PK |
| 183.89 | V | 20.39 | 43.50 | -23.11 | PK |
| 233.36 | V | 20.73 | 46.00 | -25.27 | PK |
| 55.27 | H | 22.68 | 40.00 | -17.32 | PK |
| 77.88 | H | 32.43 | 40.00 | -7.57 | PK |
| 105.72 | H | 21.17 | 43.50 | -22.33 | PK |
| 179.57 | H | 25.11 | 43.50 | -18.39 | PK |
| 252.29 | H | 31.40 | 46.00 | -14.60 | PK |
| 629.75 | H | 24.14 | 46.00 | -21.86 | PK |

- Note:**
- (1) All Readings are Peak Value.
 - (2) Emission Level= Reading Level+Probe Factor +Cable Loss.
 - (3) The average measurement was not performed when the peak measured data under the limit of average detection.
 - (4) EUT stood on the table position is the worst case result in the report.

Operation Mode: 802.11n TX Channel 11 Test Date : November 20, 2012
 Frequency Range: 30~1000MHz Temperature : 28°C
 Test Result: PASS Humidity : 65 %
 Measured Distance: 3m Test By: WOLF
 Note: Adapter 1

| Freq. (MHz) | Ant.Pol. H/V | Emission Level (dBuV/m) | Limit 3m (dBuV/m) | Over (dB) | Note |
|----------------|-----------------|----------------------------|----------------------|--------------|------|
| 36.62 | V | 21.07 | 40.00 | -18.93 | PK |
| 54.62 | V | 21.72 | 40.00 | -18.28 | PK |
| 79.15 | V | 29.29 | 40.00 | -10.71 | PK |
| 98.16 | V | 26.39 | 43.50 | -17.11 | PK |
| 181.44 | V | 24.49 | 43.50 | -19.01 | PK |
| 232.00 | V | 23.65 | 46.00 | -22.35 | PK |
| 59.27 | H | 22.68 | 40.00 | -17.32 | PK |
| 79.38 | H | 35.13 | 40.00 | -4.87 | PK |
| 108.32 | H | 21.11 | 43.50 | -22.39 | PK |
| 182.57 | H | 30.81 | 43.50 | -12.69 | PK |
| 254.74 | H | 33.76 | 46.00 | -12.24 | PK |
| 631.11 | H | 26.70 | 46.00 | -19.30 | PK |

- Note:**
- (1) All Readings are Peak Value.
 - (2) Emission Level= Reading Level+Probe Factor +Cable Loss.
 - (3) The average measurement was not performed when the peak measured data under the limit of average detection.
 - (4) EUT stood on the table position is the worst case result in the report.

Operation Mode: 802.11b TX Channel 1 Test Date : November 20, 2012
 Frequency Range: 30~1000MHz Temperature : 28°C
 Test Result: PASS Humidity : 65 %
 Measured Distance: 3m Test By: WOLF
 Note: Adapter 2

| Freq. (MHz) | Ant.Pol. H/V | Emission Level (dBuV/m) | Limit 3m (dBuV/m) | Over (dB) | Note |
|----------------|-----------------|----------------------------|----------------------|--------------|------|
| 36.22 | V | 24.24 | 40.00 | -15.76 | PK |
| 56.43 | V | 27.49 | 40.00 | -12.51 | PK |
| 85.96 | V | 33.59 | 40.00 | -6.41 | PK |
| 174.57 | V | 29.87 | 43.50 | -13.63 | PK |
| 194.78 | V | 29.49 | 43.50 | -14.01 | PK |
| 219.65 | V | 28.18 | 46.00 | -17.82 | PK |
| 54.87 | H | 25.54 | 40.00 | -14.46 | PK |
| 85.96 | H | 29.11 | 40.00 | -10.89 | PK |
| 168.35 | H | 28.94 | 43.50 | -14.56 | PK |
| 218.09 | H | 32.87 | 46.00 | -13.13 | PK |
| 258.51 | H | 29.78 | 46.00 | -16.22 | PK |
| 384.42 | H | 22.45 | 46.00 | -23.55 | PK |

- Note:**
- (1) All Readings are Peak Value.
 - (2) Emission Level= Reading Level+Probe Factor +Cable Loss.
 - (3) The average measurement was not performed when the peak measured data under the limit of average detection.
 - (4) EUT stood on the table position is the worst case result in the report.

Operation Mode: 802.11b TX Channel 6 Test Date : November 20, 2012
 Frequency Range: 30~1000MHz Temperature : 28°C
 Test Result: PASS Humidity : 65 %
 Measured Distance: 3m Test By: WOLF
 Note: Adapter 2

| Freq. (MHz) | Ant.Pol. H/V | Emission Level (dBuV/m) | Limit 3m (dBuV/m) | Over (dB) | Note |
|----------------|-----------------|----------------------------|----------------------|--------------|------|
| 37.42 | V | 24.29 | 40.00 | -15.71 | PK |
| 57.68 | V | 27.74 | 40.00 | -12.26 | PK |
| 89.52 | V | 36.04 | 40.00 | -3.96 | PK |
| 178.89 | V | 33.41 | 43.50 | -10.09 | PK |
| 193.22 | V | 28.40 | 43.50 | -15.10 | PK |
| 213.15 | V | 27.87 | 43.50 | -15.63 | PK |
| 55.27 | H | 27.90 | 40.00 | -12.10 | PK |
| 87.21 | H | 29.11 | 40.00 | -10.89 | PK |
| 164.79 | H | 29.10 | 43.50 | -14.40 | PK |
| 213.77 | H | 33.17 | 46.00 | -12.83 | PK |
| 256.95 | H | 31.84 | 46.00 | -14.16 | PK |
| 377.92 | H | 21.89 | 46.00 | -24.11 | PK |

- Note:**
- (1) All Readings are Peak Value.
 - (2) Emission Level= Reading Level+Probe Factor +Cable Loss.
 - (3) The average measurement was not performed when the peak measured data under the limit of average detection.
 - (4) EUT stood on the table position is the worst case result in the report.

Operation Mode: 802.11b TX Channel 11 Test Date : November 20, 2012
 Frequency Range: 30~1000MHz Temperature : 28°C
 Test Result: PASS Humidity : 65 %
 Measured Distance: 3m Test By: WOLF
 Note: Adapter 2

| Freq. (MHz) | Ant.Pol. H/V | Emission Level (dBuV/m) | Limit 3m (dBuV/m) | Over (dB) | Note |
|----------------|-----------------|----------------------------|----------------------|--------------|------|
| 36.62 | V | 25.47 | 40.00 | -14.53 | PK |
| 56.18 | V | 27.29 | 40.00 | -12.71 | PK |
| 86.92 | V | 36.04 | 40.00 | -3.96 | PK |
| 175.89 | V | 34.13 | 43.50 | -9.37 | PK |
| 190.77 | V | 32.50 | 43.50 | -11.00 | PK |
| 211.79 | V | 30.79 | 43.50 | -12.71 | PK |
| 59.27 | H | 27.90 | 40.00 | -12.10 | PK |
| 88.71 | H | 31.81 | 40.00 | -8.19 | PK |
| 167.39 | H | 29.04 | 43.50 | -14.46 | PK |
| 216.77 | H | 38.87 | 46.00 | -7.13 | PK |
| 259.40 | H | 34.20 | 46.00 | -11.80 | PK |
| 379.28 | H | 24.45 | 46.00 | -21.55 | PK |

- Note:**
- (1) All Readings are Peak Value.
 - (2) Emission Level= Reading Level+Probe Factor +Cable Loss.
 - (3) The average measurement was not performed when the peak measured data under the limit of average detection.
 - (4) EUT stood on the table position is the worst case result in the report.

Operation Mode: 802.11g TX Channel 1 Test Date : November 20, 2012
 Frequency Range: 30~1000MHz Temperature : 28°C
 Test Result: PASS Humidity : 65 %
 Measured Distance: 3m Test By: WOLF
 Note: Adapter 2

| Freq. (MHz) | Ant.Pol. H/V | Emission Level (dBuV/m) | Limit 3m (dBuV/m) | Over (dB) | Note |
|----------------|-----------------|----------------------------|----------------------|--------------|------|
| 37.82 | V | 24.27 | 40.00 | -15.73 | PK |
| 58.78 | V | 28.79 | 40.00 | -11.21 | PK |
| 93.42 | V | 32.73 | 40.00 | -7.27 | PK |
| 174.39 | V | 29.87 | 43.50 | -13.63 | PK |
| 193.37 | V | 29.90 | 43.50 | -13.60 | PK |
| 213.04 | V | 29.23 | 43.50 | -14.27 | PK |
| 62.83 | H | 29.10 | 40.00 | -10.90 | PK |
| 93.03 | H | 35.37 | 40.00 | -4.63 | PK |
| 168.75 | H | 27.54 | 43.50 | -15.96 | PK |
| 219.77 | H | 37.67 | 46.00 | -8.33 | PK |
| 265.90 | H | 35.70 | 46.00 | -10.30 | PK |
| 377.78 | H | 27.05 | 46.00 | -18.95 | PK |

- Note:**
- (1) All Readings are Peak Value.
 - (2) Emission Level= Reading Level+Probe Factor +Cable Loss.
 - (3) The average measurement was not performed when the peak measured data under the limit of average detection.
 - (4) EUT stood on the table position is the worst case result in the report.

Operation Mode: 802.11g TX Channel 6 Test Date : November 20, 2012
 Frequency Range: 30~1000MHz Temperature : 28°C
 Test Result: PASS Humidity : 65%
 Measured Distance: 3m Test By: WOLF
 Note: Adapter 2

| Freq. (MHz) | Ant.Pol. H/V | Emission Level (dBuV/m) | Limit 3m (dBuV/m) | Over (dB) | Note |
|----------------|-----------------|----------------------------|----------------------|--------------|------|
| 36.26 | V | 29.65 | 40.00 | -10.35 | PK |
| 74.32 | V | 32.34 | 40.00 | -7.66 | PK |
| 115.18 | V | 32.29 | 43.50 | -11.21 | PK |
| 161.95 | V | 27.19 | 43.50 | -16.31 | PK |
| 177.82 | V | 36.88 | 43.50 | -6.62 | PK |
| 245.68 | V | 31.65 | 46.00 | -14.35 | PK |
| 79.93 | H | 34.62 | 40.00 | -5.38 | PK |
| 114.79 | H | 40.68 | 43.50 | -2.82 | PK |
| 125.22 | H | 30.81 | 43.50 | -12.69 | PK |
| 163.81 | H | 35.88 | 43.50 | -7.62 | PK |
| 186.62 | H | 33.55 | 43.50 | -9.95 | PK |
| 245.65 | H | 37.30 | 46.00 | -8.70 | PK |

- Note:**
- (1) All Readings are Peak Value.
 - (2) Emission Level= Reading Level+Probe Factor +Cable Loss.
 - (3) The average measurement was not performed when the peak measured data under the limit of average detection.
 - (4) EUT stood on the table position is the worst case result in the report.

Operation Mode: 802.11g TX Channel 11 Test Date : November 20, 2012
 Frequency Range: 30~1000MHz Temperature : 28°C
 Test Result: PASS Humidity : 65 %
 Measured Distance: 3m Test By: WOLF
 Note: Adapter 2

| Freq. (MHz) | Ant.Pol. H/V | Emission Level (dBuV/m) | Limit 3m (dBuV/m) | Over (dB) | Note |
|----------------|-----------------|----------------------------|----------------------|--------------|------|
| 32.35 | V | 28.90 | 40.00 | -11.10 | PK |
| 72.61 | V | 32.19 | 40.00 | -7.81 | PK |
| 116.86 | V | 30.74 | 43.50 | -12.76 | PK |
| 156.56 | V | 27.82 | 43.50 | -15.68 | PK |
| 185.14 | V | 32.59 | 43.50 | -10.91 | PK |
| 251.41 | V | 33.24 | 46.00 | -12.76 | PK |
| 83.71 | H | 37.38 | 40.00 | -2.62 | PK |
| 117.89 | H | 39.44 | 43.50 | -4.06 | PK |
| 132.24 | H | 31.68 | 43.50 | -11.82 | PK |
| 183.18 | H | 33.88 | 43.50 | -9.62 | PK |
| 189.55 | H | 39.58 | 43.50 | -3.92 | PK |
| 255.31 | H | 38.07 | 46.00 | -7.93 | PK |

- Note:**
- (1) All Readings are Peak Value.
 - (2) Emission Level= Reading Level+Probe Factor +Cable Loss.
 - (3) The average measurement was not performed when the peak measured data under the limit of average detection.
 - (4) EUT stood on the table position is the worst case result in the report.

Operation Mode: 802.11n TX Channel 1 Test Date : November 20, 2012
 Frequency Range: 30~1000MHz Temperature : 28°C
 Test Result: PASS Humidity : 65 %
 Measured Distance: 3m Test By: WOLF
 Note: Adapter 2

| Freq. (MHz) | Ant.Pol. H/V | Emission Level (dBuV/m) | Limit 3m (dBuV/m) | Over (dB) | Note |
|----------------|-----------------|----------------------------|----------------------|--------------|------|
| 37.42 | V | 18.64 | 40.00 | -21.36 | PK |
| 57.47 | V | 23.42 | 40.00 | -16.58 | PK |
| 84.69 | V | 23.53 | 40.00 | -16.47 | PK |
| 95.34 | V | 17.87 | 43.50 | -25.63 | PK |
| 188.05 | V | 18.88 | 43.50 | -24.62 | PK |
| 241.11 | V | 19.48 | 46.00 | -26.52 | PK |
| 58.43 | H | 21.52 | 40.00 | -18.48 | PK |
| 80.95 | H | 35.99 | 40.00 | -4.01 | PK |
| 110.64 | H | 19.51 | 43.50 | -23.99 | PK |
| 186.89 | H | 23.61 | 43.50 | -19.89 | PK |
| 260.35 | H | 30.84 | 46.00 | -15.16 | PK |
| 634.75 | H | 27.30 | 46.00 | -18.70 | PK |

- Note:**
- (1) All Readings are Peak Value.
 - (2) Emission Level= Reading Level+Probe Factor +Cable Loss.
 - (3) The average measurement was not performed when the peak measured data under the limit of average detection.
 - (4) EUT stood on the table position is the worst case result in the report.

Operation Mode: 802.11n TX Channel 6 Test Date : November 20, 2012
 Frequency Range: 30~1000MHz Temperature : 28°C
 Test Result: PASS Humidity : 65 %
 Measured Distance: 3m Test By: WOLF
 Note: Adapter 2

| Freq. (MHz) | Ant.Pol. H/V | Emission Level (dBuV/m) | Limit 3m (dBuV/m) | Over (dB) | Note |
|----------------|-----------------|----------------------------|----------------------|--------------|------|
| 38.62 | V | 18.69 | 40.00 | -20.11 | PK |
| 58.72 | V | 23.67 | 40.00 | -17.83 | PK |
| 88.25 | V | 25.98 | 43.50 | -10.71 | PK |
| 99.66 | V | 27.31 | 43.50 | -11.93 | PK |
| 186.49 | V | 17.79 | 43.50 | -23.11 | PK |
| 234.61 | V | 19.17 | 46.00 | -25.27 | PK |
| 58.83 | H | 23.88 | 40.00 | -17.32 | PK |
| 82.20 | H | 35.99 | 40.00 | -7.57 | PK |
| 107.08 | H | 19.67 | 43.50 | -22.33 | PK |
| 182.57 | H | 23.91 | 43.50 | -18.39 | PK |
| 258.79 | H | 32.90 | 46.00 | -14.60 | PK |
| 628.25 | H | 26.74 | 46.00 | -21.86 | PK |

- Note:**
- (1) All Readings are Peak Value.
 - (2) Emission Level= Reading Level+Probe Factor +Cable Loss.
 - (3) The average measurement was not performed when the peak measured data under the limit of average detection.
 - (4) EUT stood on the table position is the worst case result in the report.

Operation Mode: 802.11n TX Channel 11 Test Date : November 20, 2012
 Frequency Range: 30~1000MHz Temperature : 28°C
 Test Result: PASS Humidity : 65 %
 Measured Distance: 3m Test By: WOLF
 Note: Adapter 2

| Freq. (MHz) | Ant.Pol. H/V | Emission Level (dBuV/m) | Limit 3m (dBuV/m) | Over (dB) | Note |
|----------------|-----------------|----------------------------|----------------------|--------------|------|
| 37.82 | V | 19.87 | 40.00 | -20.13 | PK |
| 57.22 | V | 23.22 | 40.00 | -16.78 | PK |
| 85.65 | V | 25.98 | 40.00 | -14.02 | PK |
| 96.66 | V | 22.13 | 43.50 | -21.37 | PK |
| 184.04 | V | 21.89 | 43.50 | -21.61 | PK |
| 233.25 | V | 22.09 | 46.00 | -23.91 | PK |
| 62.83 | H | 23.88 | 40.00 | -16.12 | PK |
| 83.70 | H | 36.61 | 40.00 | -3.39 | PK |
| 109.68 | H | 19.61 | 43.50 | -23.89 | PK |
| 185.57 | H | 29.61 | 43.50 | -13.89 | PK |
| 261.24 | H | 35.26 | 46.00 | -10.74 | PK |
| 629.61 | H | 29.30 | 46.00 | -16.70 | PK |

- Note:**
- (1) All Readings are Peak Value.
 - (2) Emission Level= Reading Level+Probe Factor +Cable Loss.
 - (3) The average measurement was not performed when the peak measured data under the limit of average detection.
 - (4) EUT stood on the table position is the worst case result in the report.

Operation Mode: 802.11b TX Channel 1 Test Date : November 20, 2012
 Frequency Range: Above 1GHz Temperature : 28°C
 Test Result: PASS Humidity : 65 %
 Measured Distance: 3m Test By: WOLF
 Note: Adapter 1

| Freq. (MHz) | Ant.Pol. H/V | Emission Level(dBuV/m) | | Limit 3m(dBuV/m) | | Over(dB) | |
|----------------|-----------------|------------------------|-------|---------------------|-------|----------|--------|
| | | PK | AV | PK | AV | PK | AV |
| 4814.10 | V | 46.79 | 29.31 | 74.00 | 54.00 | -27.21 | -24.69 |
| 7402.24 | V | 51.90 | 35.44 | 74.00 | 54.00 | -22.10 | -18.56 |
| 7838.14 | V | 51.80 | 33.50 | 74.00 | 54.00 | -22.20 | -20.50 |
| -- | -- | -- | -- | -- | -- | -- | -- |
| -- | -- | -- | -- | -- | -- | -- | -- |
| -- | -- | -- | -- | -- | -- | -- | -- |
| 9690.71 | H | 52.50 | 35.05 | 74.00 | 54.00 | -21.50 | -18.95 |
| 10235.57 | H | 51.41 | 34.02 | 74.00 | 54.00 | -22.59 | -19.98 |
| 14458.33 | H | 53.26 | 35.17 | 74.00 | 54.00 | -20.74 | -18.83 |

All emissions not reported were more than 20dB below the specified limit or in the noise floor.

- Note:**
- (1) All Readings are Peak Value and AV.
 - (2) Emission Level= Reading Level+Probe Factor +Cable Loss.
 - (3) Data of measurement within this frequency range shown “ -- ” in the table above means the reading of emissions are attenuated more than 20dB below the permissible limits or the field strength is too small to be measured.

Operation Mode: 802.11b TX Channel 6 Test Date : November 20, 2012
 Frequency Range: Above 1GHz Temperature : 28°C
 Test Result: PASS Humidity : 65 %
 Measured Distance: 3m Test By: WOLF
 Note: Adapter 1

| Freq. (MHz) | Ant.Pol. H/V | Emission Level(dBuV/m) | | Limit 3m(dBuV/m) | | Over(dB) | |
|----------------|-----------------|------------------------|-------|---------------------|-------|----------|--------|
| | | PK | AV | PK | AV | PK | AV |
| 5277.24 | V | 46.94 | 29.42 | 74.00 | 54.00 | -27.06 | -24.58 |
| 7238.78 | V | 54.98 | 37.94 | 74.00 | 54.00 | -19.02 | -16.06 |
| 7810.90 | V | 52.13 | 34.40 | 74.00 | 54.00 | -21.87 | -19.60 |
| -- | -- | -- | -- | -- | -- | -- | -- |
| -- | -- | -- | -- | -- | -- | -- | -- |
| -- | -- | -- | -- | -- | -- | -- | -- |
| 9935.90 | H | 53.03 | 36.73 | 74.00 | 54.00 | -20.97 | -17.27 |
| 11243.59 | H | 51.01 | 35.78 | 74.00 | 54.00 | -22.99 | -18.22 |
| 13913.46 | H | 53.01 | 37.63 | 74.00 | 54.00 | -20.99 | -16.37 |

All emissions not reported were more than 20dB below the specified limit or in the noise floor.

- Note:**
- (1) All Readings are Peak Value and AV.
 - (2) Emission Level= Reading Level+Probe Factor +Cable Loss.
 - (3) Data of measurement within this frequency range shown “ -- ” in the table above means the reading of emissions are attenuated more than 20dB below the permissible limits or the field strength is too small to be measured.

Operation Mode: 802.11b TX (Channel 11) Test Date : November 20, 2012
 Frequency Range: Above 1GHz Temperature : 28°C
 Test Result: PASS Humidity : 65 %
 Measured Distance: 3m Test By: WOLF
 Note: Adapter 1

| Freq. (MHz) | Ant.Pol. H/V | Emission Level(dBuV/m) | | Limit 3m(dBuV/m) | | Over(dB) | |
|----------------|-----------------|------------------------|-------|---------------------|-------|----------|--------|
| | | PK | AV | PK | AV | PK | AV |
| 4814.10 | V | 46.79 | 29.31 | 74.00 | 54.00 | -27.21 | -24.69 |
| 7402.24 | V | 51.90 | 35.44 | 74.00 | 54.00 | -22.10 | -18.56 |
| 7838.14 | V | 51.80 | 33.50 | 74.00 | 54.00 | -22.20 | -20.50 |
| -- | -- | -- | -- | -- | -- | -- | -- |
| -- | -- | -- | -- | -- | -- | -- | -- |
| -- | -- | -- | -- | -- | -- | -- | -- |
| 9690.71 | H | 52.50 | 35.05 | 74.00 | 54.00 | -21.50 | -18.95 |
| 10235.57 | H | 51.41 | 34.02 | 74.00 | 54.00 | -22.59 | -19.98 |
| 14458.33 | H | 53.26 | 35.17 | 74.00 | 54.00 | -20.74 | -18.83 |

No others harmonics emissions are higher than 20dB below the limits of 47 CFR Part 15.247.

- Note:**
- (1) All Readings are Peak Value and AV.
 - (2) Emission Level= Reading Level+Probe Factor +Cable Loss.
 - (3) Data of measurement within this frequency range shown “ -- ” in the table above means the reading of emissions are attenuated more than 20dB below the permissible limits or the field strength is too small to be measured.

Operation Mode: 802.11g TX Channel 1 Test Date : November 20, 2012
 Frequency Range: Above 1GHz Temperature : 28°C
 Test Result: PASS Humidity : 65 %
 Measured Distance: 3m Test By: WOLF
 Note: Adapter 1

| Freq. (MHz) | Ant.Pol. H/V | Emission Level(dBuV/m) | | Limit 3m(dBuV/m) | | Over(dB) | |
|----------------|-----------------|------------------------|-------|---------------------|-------|----------|--------|
| | | PK | AV | PK | AV | PK | AV |
| 4923.08 | V | 47.55 | 29.70 | 74.00 | 54.00 | -26.45 | -24.30 |
| 7238.78 | V | 51.21 | 34.25 | 74.00 | 54.00 | -22.79 | -19.75 |
| 8028.85 | V | 51.70 | 33.95 | 74.00 | 54.00 | -22.30 | -20.05 |
| -- | -- | -- | -- | -- | -- | -- | -- |
| -- | -- | -- | -- | -- | -- | -- | -- |
| -- | -- | -- | -- | -- | -- | -- | -- |
| 9963.14 | H | 53.42 | 36.82 | 74.00 | 54.00 | -20.58 | -17.18 |
| 11243.59 | H | 50.36 | 32.48 | 74.00 | 54.00 | -23.64 | -21.52 |
| 13777.24 | H | 52.96 | 37.30 | 74.00 | 54.00 | -21.04 | -16.70 |

All emissions not reported were more than 20dB below the specified limit or in the noise floor.

- Note:**
- (1) All Readings are Peak Value and AV.
 - (2) Emission Level= Reading Level +Probe Factor +Cable Loss.
 - (3) Data of measurement within this frequency range shown “ -- ” in the table above means the reading of emissions are attenuated more than 20dB below the permissible limits or the field strength is too small to be measured.

Operation Mode: 802.11g TX (Channel 6) Test Date : November 20, 2012
 Frequency Range: Above 1GHz Temperature : 28°C
 Test Result: PASS Humidity : 65 %
 Measured Distance: 3m Test By: WOLF
 Note: Adapter 1

| Freq. (MHz) | Ant.Pol. H/V | Emission Level(dBuV/m) | | Limit 3m(dBuV/m) | | Over(dB) | |
|----------------|-----------------|------------------------|-------|---------------------|-------|----------|--------|
| | | PK | AV | PK | AV | PK | AV |
| 4923.08 | V | 48.09 | 31.30 | 74.00 | 54.00 | -25.91 | -22.70 |
| 7184.30 | V | 51.71 | 34.30 | 74.00 | 54.00 | -22.29 | -19.70 |
| 7402.24 | V | 53.66 | 36.15 | 74.00 | 54.00 | -20.34 | -17.85 |
| -- | -- | -- | -- | -- | -- | -- | -- |
| -- | -- | -- | -- | -- | -- | -- | -- |
| -- | -- | -- | -- | -- | -- | -- | -- |
| 9227.56 | H | 52.39 | 35.80 | 74.00 | 54.00 | -21.61 | -18.20 |
| 10480.76 | H | 52.45 | 35.62 | 74.00 | 54.00 | -21.55 | -18.38 |
| 14649.03 | H | 52.61 | 36.11 | 74.00 | 54.00 | -21.39 | -17.89 |

All emissions not reported were more than 20dB below the specified limit or in the noise floor.

- Note:**
- (1) All Readings are Peak Value and AV.
 - (2) Emission Level= Reading Level+Probe Factor +Cable Loss.
 - (3) Data of measurement within this frequency range shown "--" in the table above means the reading of emissions are attenuated more than 20dB below the permissible limits or the field strength is too small to be measured.

Operation Mode: 802.11g TX (Channel 11) Test Date : November 20, 2012
 Frequency Range: Above 1GHz Temperature : 28°C
 Test Result: PASS Humidity : 65 %
 Measured Distance: 3m Test By: WOLF
 Note: Adapter 1

| Freq. (MHz) | Ant.Pol. H/V | Emission Level(dBuV/m) | | Limit 3m(dBuV/m) | | Over(dB) | |
|----------------|-----------------|------------------------|-------|------------------|-------|----------|--------|
| | | PK | AV | PK | AV | PK | AV |
| 4814.10 | V | 48.79 | 30.41 | 74.00 | 54.00 | -25.21 | -23.59 |
| 7238.78 | V | 53.30 | 34.45 | 74.00 | 54.00 | -20.70 | -19.55 |
| 9309.30 | V | 51.75 | 34.62 | 74.00 | 54.00 | -22.25 | -19.38 |
| -- | -- | -- | -- | -- | -- | -- | -- |
| -- | -- | -- | -- | -- | -- | -- | -- |
| -- | -- | -- | -- | -- | -- | -- | -- |
| 9963.14 | H | 52.40 | 36.12 | 74.00 | 54.00 | -21.60 | -17.88 |
| 11025.64 | H | 51.95 | 35.50 | 74.00 | 54.00 | -22.05 | -18.50 |
| 14567.30 | H | 52.90 | 36.36 | 74.00 | 54.00 | -21.10 | -17.64 |

No others harmonics emissions are higher than 20dB below the limits of 47 CFR Part 15.247.

- Note:**
- (1) All Readings are Peak Value and AV.
 - (2) Emission Level= Reading Level+Probe Factor +Cable Loss.
 - (3) Data of measurement within this frequency range shown "--" in the table above means the reading of emissions are attenuated more than 20dB below the permissible limits or the field strength is too small to be measured.

Operation Mode: 802.11n TX Channel 1 Test Date : November 20, 2012
 Frequency Range: Above 1GHz Temperature : 28°C
 Test Result: PASS Humidity : 65 %
 Measured Distance: 3m Test By: WOLF
 Note: Adapter 1

| Freq. (MHz) | Ant.Pol. H/V | Emission Level(dBuV/m) | | Limit 3m(dBuV/m) | | Over(dB) | |
|----------------|-----------------|------------------------|-------|------------------|-------|----------|--------|
| | | PK | AV | PK | AV | PK | AV |
| 4814.10 | V | 47.83 | 31.20 | 74.00 | 54.00 | -26.17 | -22.80 |
| 6911.86 | V | 48.05 | 30.83 | 74.00 | 54.00 | -25.95 | -23.17 |
| 7238.78 | V | 55.51 | 39.04 | 74.00 | 54.00 | -18.49 | -14.96 |
| -- | -- | -- | -- | -- | -- | -- | -- |
| -- | -- | -- | -- | -- | -- | -- | -- |
| -- | -- | -- | -- | -- | -- | -- | -- |
| 7919.87 | H | 51.53 | 34.89 | 74.00 | 54.00 | -22.47 | -19.11 |
| 10399.03 | H | 51.98 | 45.12 | 74.00 | 54.00 | -22.02 | -8.88 |
| 14512.82 | H | 53.13 | 48.50 | 74.00 | 54.00 | -20.87 | -5.50 |

All emissions not reported were more than 20dB below the specified limit or in the noise floor.

- Note:**
- (1) All Readings are Peak Value and AV.
 - (2) Emission Level= Reading Level+Probe Factor +Cable Loss.
 - (3) Data of measurement within this frequency range shown “ -- ” in the table above means the reading of emissions are attenuated more than 20dB below the permissible limits or the field strength is too small to be measured.

Operation Mode: 802.11n TX (Channel 6) Test Date : November 20, 2012
 Frequency Range: Above 1GHz Temperature : 28°C
 Test Result: PASS Humidity : 65 %
 Measured Distance: 3m Test By: WOLF
 Note: Adapter 1

| Freq. (MHz) | Ant.Pol. H/V | Emission Level(dBuV/m) | | Limit 3m(dBuV/m) | | Over(dB) | |
|----------------|-----------------|------------------------|-------|------------------|-------|----------|--------|
| | | PK | AV | PK | AV | PK | AV |
| 4923.08 | V | 51.38 | 34.30 | 74.00 | 54.00 | -22.62 | -19.70 |
| 7375.00 | V | 50.92 | 32.81 | 74.00 | 54.00 | -23.08 | -21.19 |
| 7974.36 | V | 50.91 | 33.90 | 74.00 | 54.00 | -23.09 | -20.10 |
| -- | -- | -- | -- | -- | -- | -- | -- |
| -- | -- | -- | -- | -- | -- | -- | -- |
| -- | -- | -- | -- | -- | -- | -- | -- |
| 9799.68 | H | 49.83 | 33.87 | 74.00 | 54.00 | -24.17 | -20.13 |
| 13150.64 | H | 47.81 | 31.60 | 74.00 | 54.00 | -26.19 | -22.40 |
| 14512.82 | H | 48.72 | 43.11 | 74.00 | 54.00 | -25.28 | -10.89 |

All emissions not reported were more than 20dB below the specified limit or in the noise floor.

- Note:**
- (1) All Readings are Peak Value and AV.
 - (2) Emission Level= Reading Level+Probe Factor +Cable Loss.
 - (3) Data of measurement within this frequency range shown “ -- ” in the table above means the reading of emissions are attenuated more than 20dB below the permissible limits or the field strength is too small to be measured.

Operation Mode: 802.11n TX (Channel 11) Test Date : November 20, 2012
 Frequency Range: Above 1GHz Temperature : 28°C
 Test Result: PASS Humidity : 65 %
 Measured Distance: 3m Test By: WOLF
 Note: Adapter 1

| Freq. (MHz) | Ant.Pol. H/V | Emission Level(dBuV/m) | | Limit 3m(dBuV/m) | | Over(dB) | |
|----------------|-----------------|------------------------|-------|------------------|-------|----------|--------|
| | | PK | AV | PK | AV | PK | AV |
| 4923.08 | V | 51.51 | 34.30 | 74.00 | 54.00 | -22.49 | -19.70 |
| 5931.09 | V | 46.85 | 29.13 | 74.00 | 54.00 | -27.15 | -24.87 |
| 7375.00 | V | 55.62 | 38.62 | 74.00 | 54.00 | -18.38 | -15.38 |
| -- | -- | -- | -- | -- | -- | -- | -- |
| -- | -- | -- | -- | -- | -- | -- | -- |
| -- | -- | -- | -- | -- | -- | -- | -- |
| 9227.56 | H | 51.06 | 34.30 | 74.00 | 54.00 | -22.94 | -19.70 |
| 10862.17 | H | 52.46 | 35.76 | 74.00 | 54.00 | -21.54 | -18.24 |
| 13750.00 | H | 52.72 | 34.04 | 74.00 | 54.00 | -21.28 | -19.96 |

No others harmonics emissions are higher than 20dB below the limits of 47 CFR Part 15.247.

- Note:**
- (1) All Readings are Peak Value and AV.
 - (2) Emission Level= Reading Level+Probe Factor +Cable Loss.
 - (3) Data of measurement within this frequency range shown “ -- ” in the table above means the reading of emissions are attenuated more than 20dB below the permissible limits or the field strength is too small to be measured.

6.6 Radiated Measurement Photos

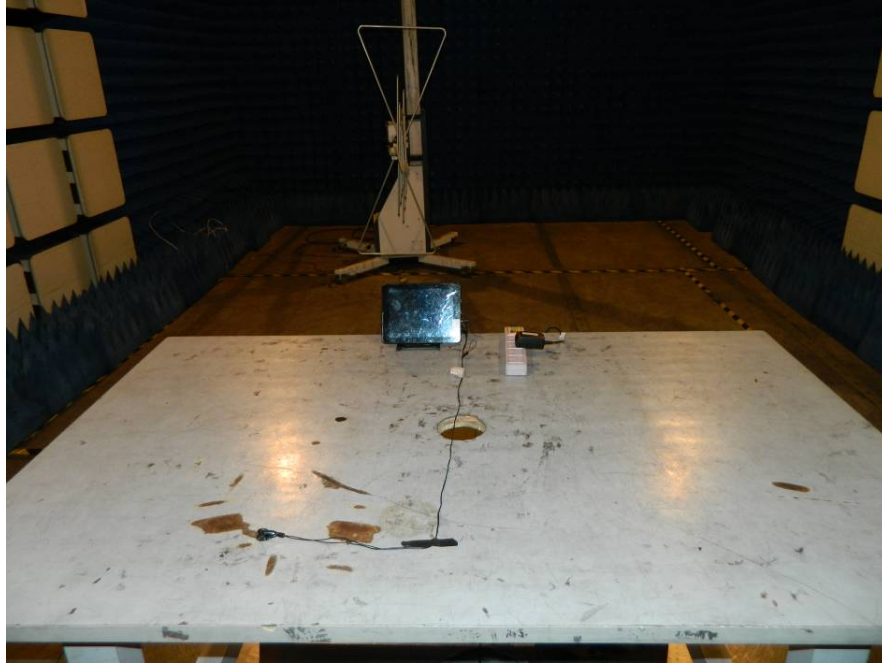



7. Occupied Bandwidth Test

7.1 Measurement Procedure

The EUT was operating in IEEE 802.11b/g/n mode or could be controlled its channel. Printed out the test result from the spectrum by hard copy function.

7.2 Test SET-UP (Block Diagram of Configuration)

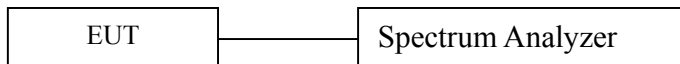

7.3 Measurement Equipment Used

| EQUIPMENT TYPE | MFR | MODEL NUMBER | SERIAL NUMBER | LAST CAL. | CAL DUE. |
|-------------------|---------|--------------|---------------|------------|------------|
| Spectrum Analyzer | Agilent | E4407B | 88156318 | 05/29/2012 | 05/28/2013 |

7.4 Measurement Results

6 Bandwidth Test Data Chart:
Refer to attached data chart.

Spectrum Detector: PK Test Date : November 20, 2012
 Test By: Andy Temperature : 28°C
 Test Result: PASS Humidity : 65 %
 Operation Mode: 802.11b

| Channel number | Channel frequency (MHz) | Measurement level (MHz) | Required Limit (kHz) |
|----------------|-------------------------|-------------------------|----------------------|
| 1 | 2412 | 10.454 | >500 |
| 6 | 2437 | 10.437 | >500 |
| 11 | 2462 | 10.439 | >500 |

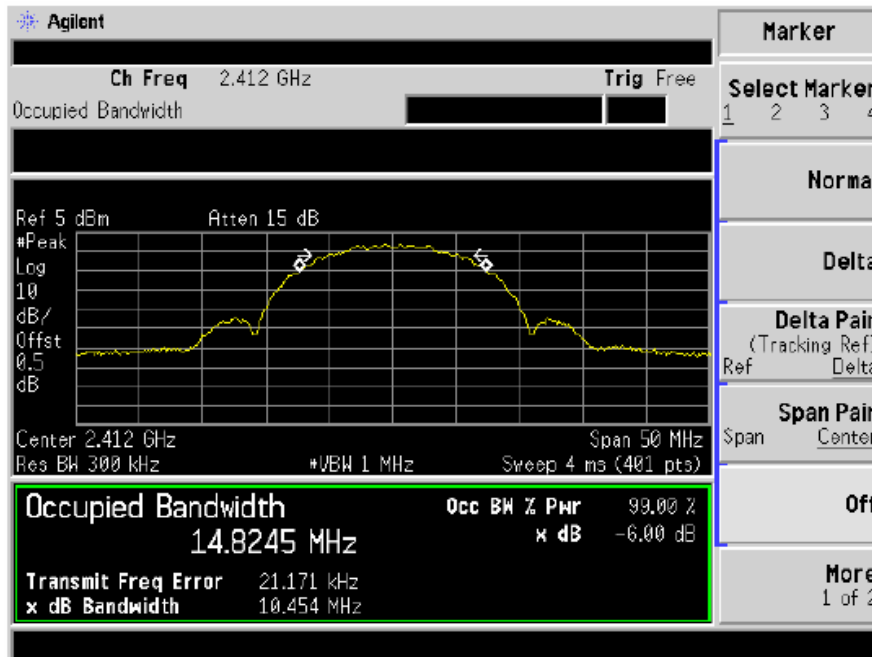

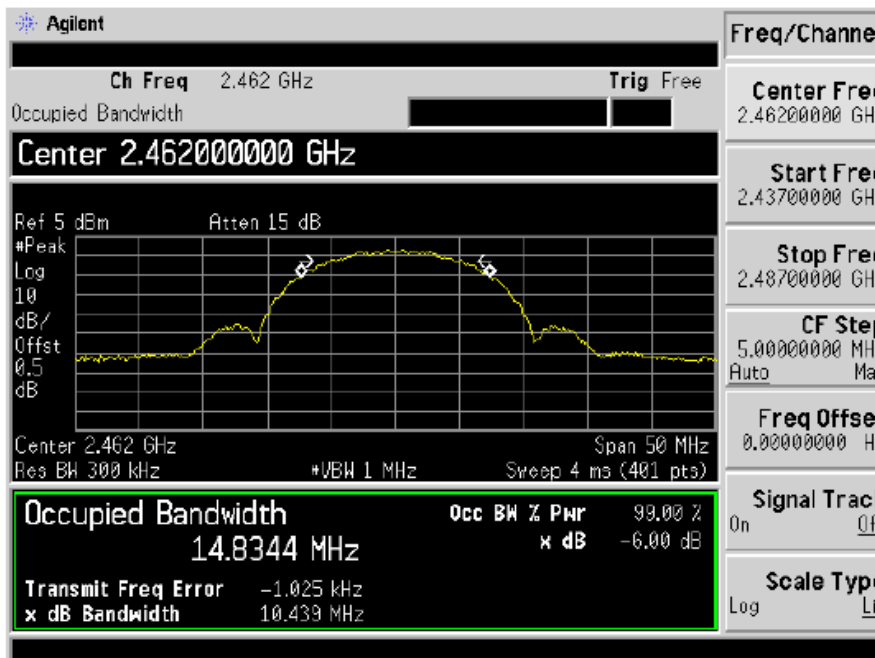
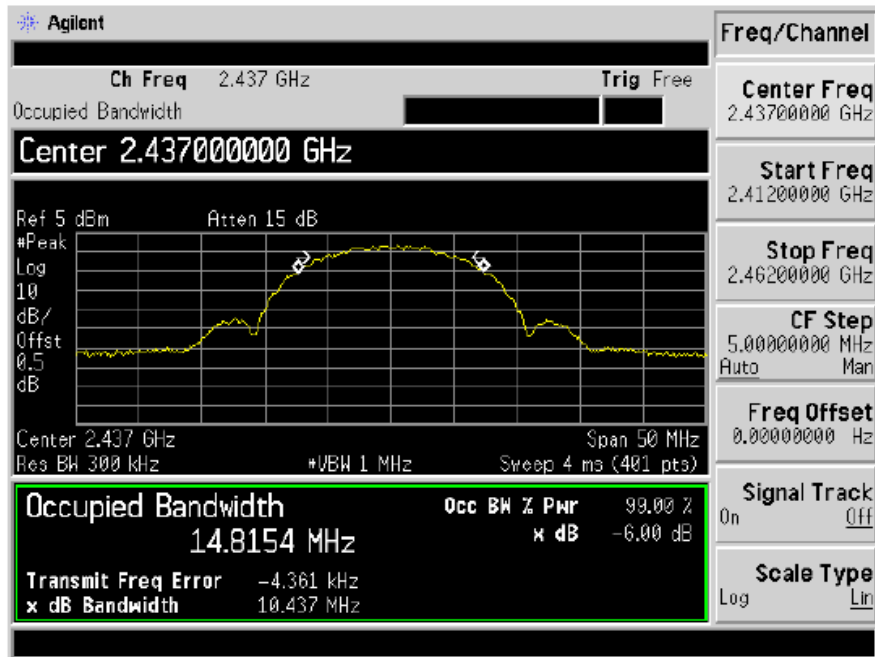

Spectrum Detector: PK Test Date : November 20, 2012
 Test By: Andy Temperature : 28°C
 Test Result: PASS Humidity : 65 %
 Operation Mode: 802.11 g

| Channel number | Channel frequency (MHz) | Measurement level (MHz) | Required Limit (kHz) |
|----------------|-------------------------|-------------------------|----------------------|
| 1 | 2412 | 16.601 | >500 |
| 6 | 2437 | 16.520 | >500 |
| 11 | 2462 | 16.607 | >500 |

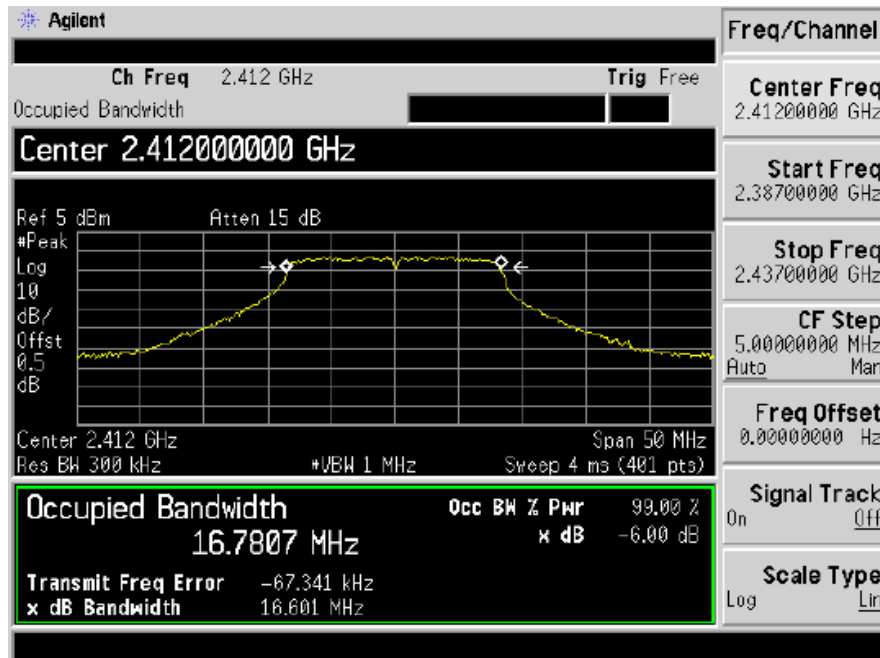

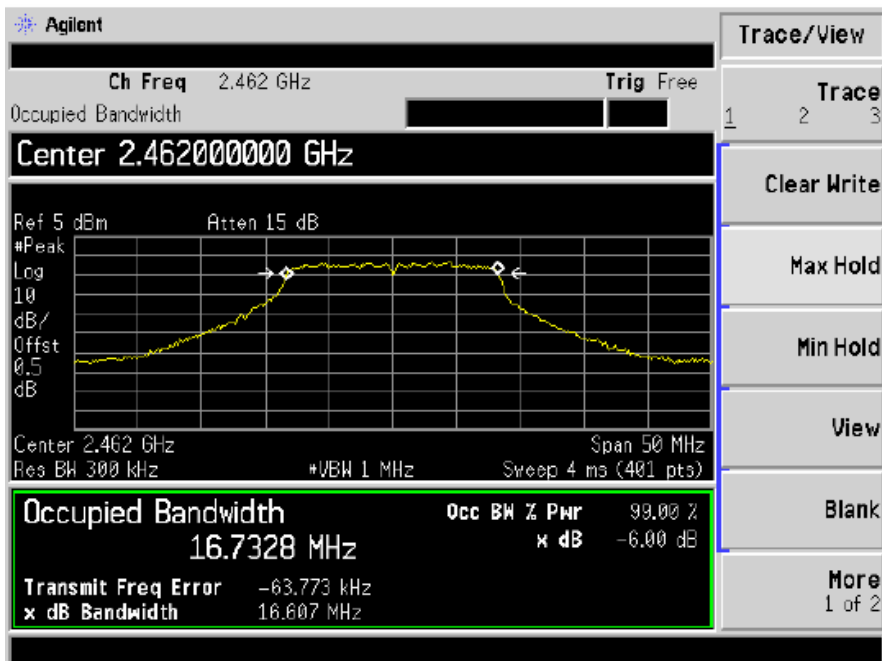
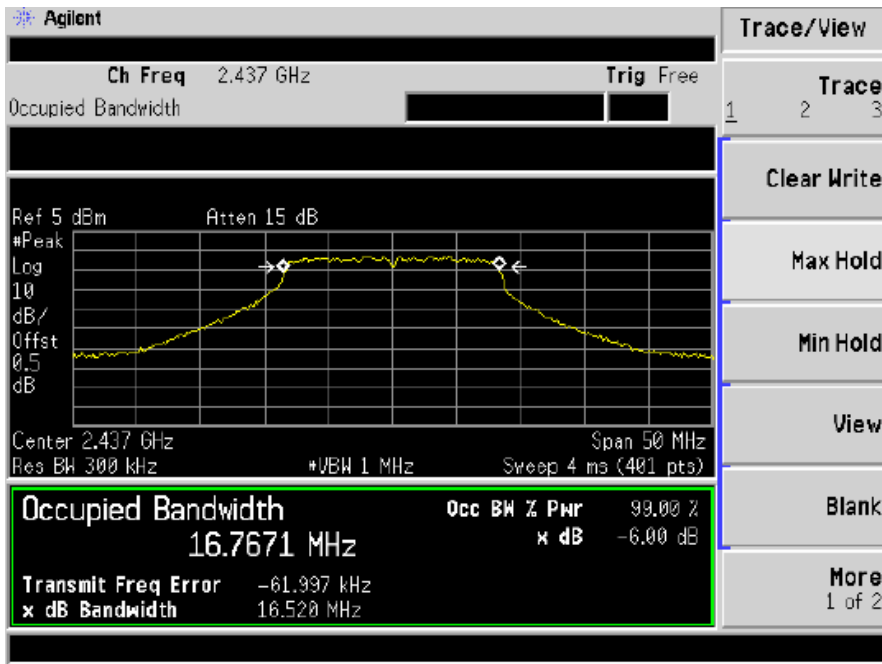

Spectrum Detector: PK Test Date : November 20, 2012
 Test By: Andy Temperature : 28°C
 Test Result: PASS Humidity : 65 %
 Operation Mode: 802.11 n HT 20

| Channel number | Channel frequency (MHz) | Measurement level (MHz) | Required Limit (kHz) |
|----------------|-------------------------|-------------------------|----------------------|
| 1 | 2412 | 17.657 | >500 |
| 6 | 2437 | 17.804 | >500 |
| 11 | 2462 | 17.813 | >500 |

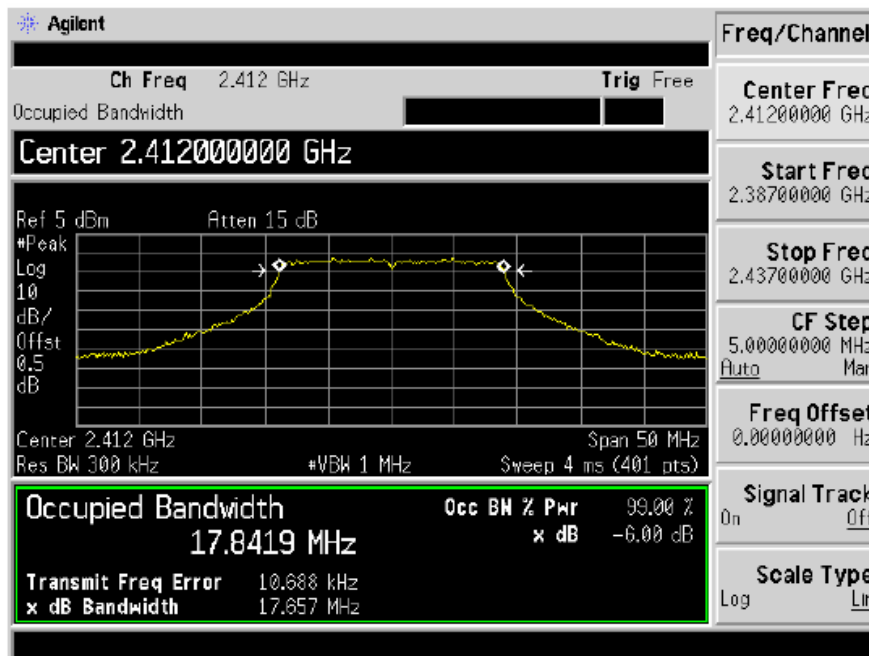

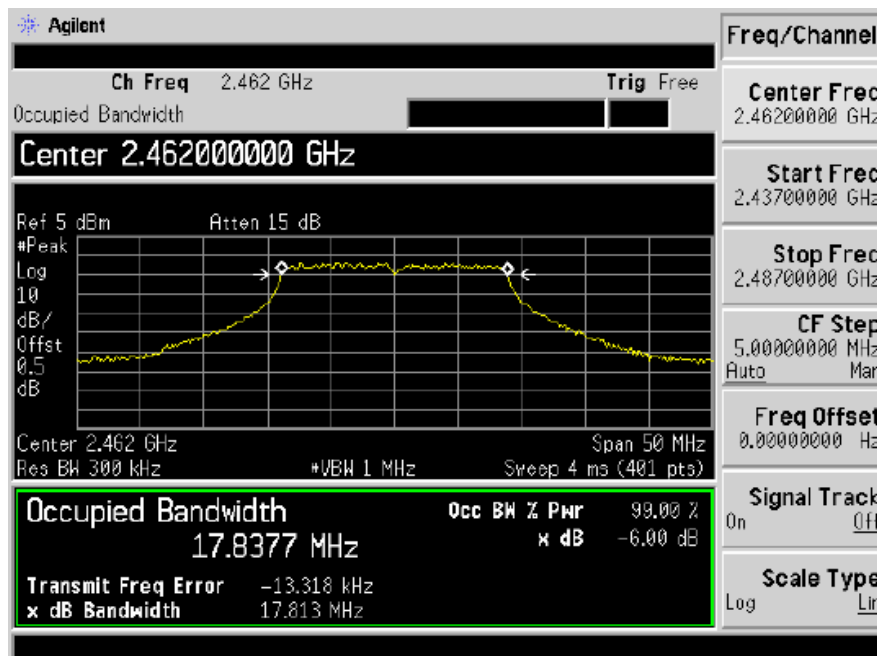
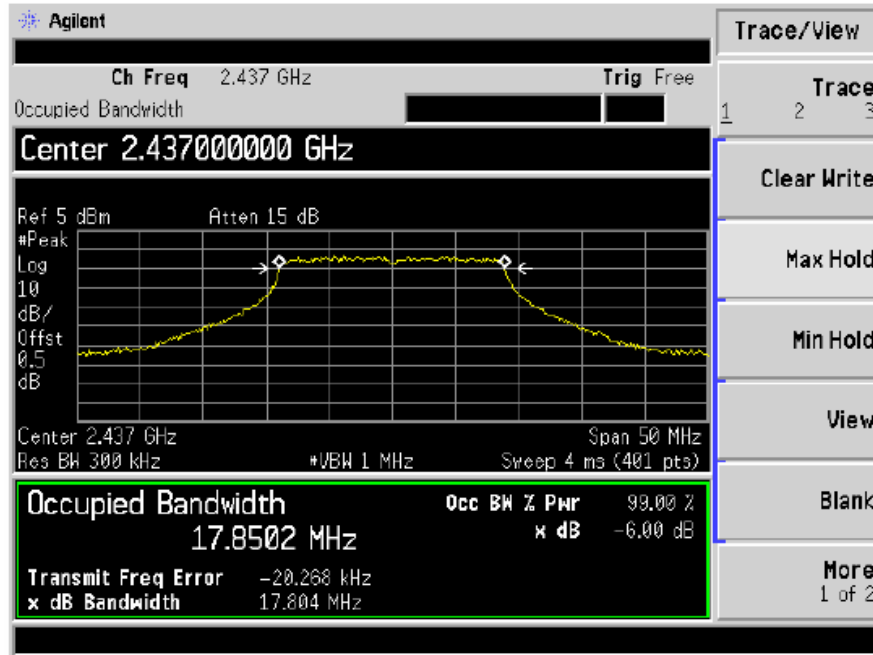

8. Maximum Peak Output Power Test

8.1 Measurement Procedure

- a. The Transmitter output (antenna port) was connected to the power meter.
- b. Turn on the EUT and power meter and then record the peak power value.
- c. Repeat above procedures on all channels needed to be tested.

8.2 Test SET-UP (Block Diagram of Configuration)

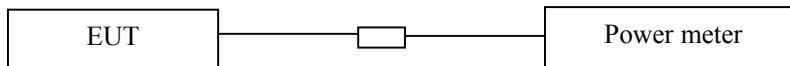

8.3 Measurement Equipment Used

| EQUIPMENT TYPE | MFR | MODEL NUMBER | SERIAL NUMBER | LAST CAL. | CAL DUE. |
|----------------|---------|--------------|---------------|------------|------------|
| Power meter | Boonton | 4232A | 29001 | 05/29/2012 | 05/28/2013 |
| Power sensor | Boonton | 51011-EMC | 31184 | 05/29/2012 | 05/28/2013 |

8.4 Peak Power output limit

The maximum peak power shall be less 1Watt.

8.5 Measurement Results

| | | | |
|-------------------------|------|---------------|-------------------|
| Spectrum Detector: | PK | Test Date : | November 20, 2012 |
| Test By: | Andy | Temperature : | 28°C |
| Test Result: | PASS | Humidity : | 65 % |
| Operation Mode: 802.11b | | | |

| Channel number | Channel Frequency(MHz) | Peak Power output(dBm) | Peak Power Limit(W) | Pass/Fail |
|----------------|------------------------|------------------------|---------------------|-----------|
| 1 | 2412 | 10.61 | 1W(30dBm) | PASS |
| 6 | 2437 | 9.38 | 1W(30dBm) | PASS |
| 11 | 2462 | 9.33 | 1W(30dBm) | PASS |

Spectrum Detector: PK Test Date : November 20, 2012
 Test By: Andy Temperature : 28°C
 Test Result: PASS Humidity : 65 %
 Operation Mode: 802.11g

| Channel number | Channel Frequency (MHz) | Peak Power output(dBm) | Peak Power Limit(W) | Pass/Fail |
|----------------|-------------------------|------------------------|---------------------|-----------|
| 1 | 2412.00 | 7.95 | 1W(30dBm) | PASS |
| 6 | 2437.00 | 7.78 | 1W(30dBm) | PASS |
| 11 | 2462.00 | 7.69 | 1W(30dBm) | PASS |

Spectrum Detector: PK Test Date : November 20, 2012
 Test By: Andy Temperature : 28°C
 Test Result: PASS Humidity : 65 %
 Operation Mode: 802.11n

| Channel number | Channel Frequency (MHz) | Peak Power output(dBm) | Peak Power Limit(W) | Pass/Fail |
|----------------|-------------------------|------------------------|---------------------|-----------|
| 1 | 2412.00 | 7.84 | 1W(30dBm) | PASS |
| 6 | 2437.00 | 7.78 | 1W(30dBm) | PASS |
| 11 | 2462.00 | 7.36 | 1W(30dBm) | PASS |

9. Band Edge Test

9.1 Measurement Procedure

1. The EUT was Operating in hopping mode or could be controlled its channel. Printed out test result from the spectrum by hard copy function.
2. The EUT was placed on a turn table which is 0.8m above ground plane.
3. Maximum procedure was performed on the six highest emissions to ensure EUT compliance.
4. And also, each emission was to be maximized by changing the polarization of receiving antenna both horizontal and vertical.
5. Repeat above procedures until all frequency measured were complete.

9.2 Test SET-UP (Block Diagram of Configuration)

As 6.2 Test set up (B) and (C)

9.3 Measurement Equipment Used

Same as 6.3 Radiated Emission Measurement.

9.4 Measurement Results

Test mode: 802.11b

| | | | |
|--------------------|-------|---------------|-------------------|
| Spectrum Detector: | PK/AV | Test Date : | November 20, 2012 |
| Test By: | Andy | Temperature : | 28 °C |
| Test channel: | 01 | Humidity : | 65 % |

| Frequency (MHz) | Polarity | Level (dBuV/m) | | Limited (dBuV/m) | |
|-----------------|----------|----------------|-------|------------------|----|
| | | PK | AV | PK | AV |
| 2390.00 | H | 45.02 | 33.67 | 74 | 54 |
| 2390.00 | V | 45.14 | 33.73 | 74 | 54 |

| | | | |
|--------------------|-------|---------------|-------------------|
| Spectrum Detector: | PK/AV | Test Date : | November 20, 2012 |
| Test By: | Andy | Temperature : | 28 °C |
| Test channel: | 11 | Humidity : | 65 % |

| Frequency (MHz) | Polarity | Level (dBuV/m) | | Limited (dBuV/m) | |
|-----------------|----------|----------------|-------|------------------|----|
| | | PK | AV | PK | AV |
| 2483.50 | H | 44.76 | 33.64 | 74 | 54 |
| 2483.50 | V | 43.91 | 32.83 | 74 | 54 |

Test mode: 802.11g

Spectrum Detector: PK/AV Test Date : November 20, 2012
 Test By: Andy Temperature : 28 °C
 Test channel: 01 Humidity : 65 %

| Frequency (MHz) | Polarity | Level (dBuV/m) | | Limited (dBuV/m) | |
|-----------------|----------|----------------|-------|------------------|----|
| | | PK | AV | PK | AV |
| 2390.00 | H | 45.37 | 34.02 | 74 | 54 |
| 2390.00 | V | 44.88 | 33.09 | 74 | 54 |

Spectrum Detector: PK/AV Test Date : November 20, 2012
 Test By: Andy Temperature : 28 °C
 Test channel: 11 Humidity : 65 %

| Frequency (MHz) | Polarity | Level (dBuV/m) | | Limited (dBuV/m) | |
|-----------------|----------|----------------|-------|------------------|----|
| | | PK | AV | PK | AV |
| 2483.50 | H | 45.41 | 33.88 | 74 | 54 |
| 2483.50 | V | 42.98 | 31.98 | 74 | 54 |

Test mode: 802.11n

Spectrum Detector: PK/AV Test Date : November 20, 2012
 Test By: Andy Temperature : 28 °C
 Test channel: 01 Humidity : 65 %

| Frequency (MHz) | Polarity | Level (dBuV/m) | | Limited (dBuV/m) | |
|-----------------|----------|----------------|-------|------------------|----|
| | | PK | AV | PK | AV |
| 2390.00 | H | 45.27 | 33.79 | 74 | 54 |
| 2390.00 | V | 45 | 34.17 | 74 | 54 |

Spectrum Detector: PK/AV Test Date : November 20, 2012
 Test By: Andy Temperature : 28 °C
 Test channel: 11 Humidity : 65 %

| Frequency (MHz) | Polarity | Level (dBuV/m) | | Limited (dBuV/m) | |
|-----------------|----------|----------------|-------|------------------|----|
| | | PK | AV | PK | AV |
| 2483.50 | H | 45.74 | 34.39 | 74 | 54 |
| 2483.50 | V | 42.93 | 32.51 | 74 | 54 |
| | | | | | |

10. Power Density

10.1 Test Equipment

| EQUIPMENT TYPE | MFR | MODEL NUMBER | SERIAL NUMBER | LAST CAL. | CAL DUE. |
|-------------------|---------|--------------|---------------|------------|------------|
| Spectrum Analyzer | Agilent | E4407B | 88156318 | 05/29/2012 | 05/28/2013 |

10.2 Measuring Instruments and Setting

The following table is the setting of spectrum analyzer.

| Spectrum analyzer | Setting |
|-------------------|-------------|
| Attenuation | Auto |
| Span Frequency | 20MHz-40MHz |
| RB | 100kHz |
| VB | 300kHz |
| Detector | Peak |
| Trace | Max hold |
| Sweep Time | Automatic |

10.3 Test Procedures

- a. The transmitter output (antenna port) was connected to the spectrum analyzer.
- b. Set RBW of spectrum analyzer to 100 kHz and VBW to 300 kHz, Set Detector to Peak and Trace to Max Hold.
- c. Mark the frequency with maximum peak power as the center of the display of the spectrum.
- d. Set the span to 200 kHz and the sweep time to auto and record the maximum peak value.
- e. BWCF = $10\log(3\text{kHz}/100\text{kHz}) = -15.2\text{ dB}$. Set offset -15.2dbm

10.4 Block Diagram of Test Setup

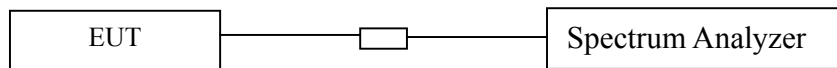

10.5 Limit

The transmitted power density averaged over any 1 second interval shall not be greater +8dBm in any 100 kHz bandwidth.

10.6 Test Result

Spectrum Detector: PK Test Date : November 20, 2012
 Test By: Andy Temperature : 28°C
 Test Result: PASS Humidity : 65 %
 Operation Mode: 802.11 b

| Channel | Measurement Level (dBm) | Required Limit (dBm) | Result |
|---------|-------------------------|----------------------|--------|
| 1 | -26.52 | <8dBm | PASS |
| 6 | -26.53 | <8dBm | PASS |
| 11 | -26.59 | <8dBm | PASS |

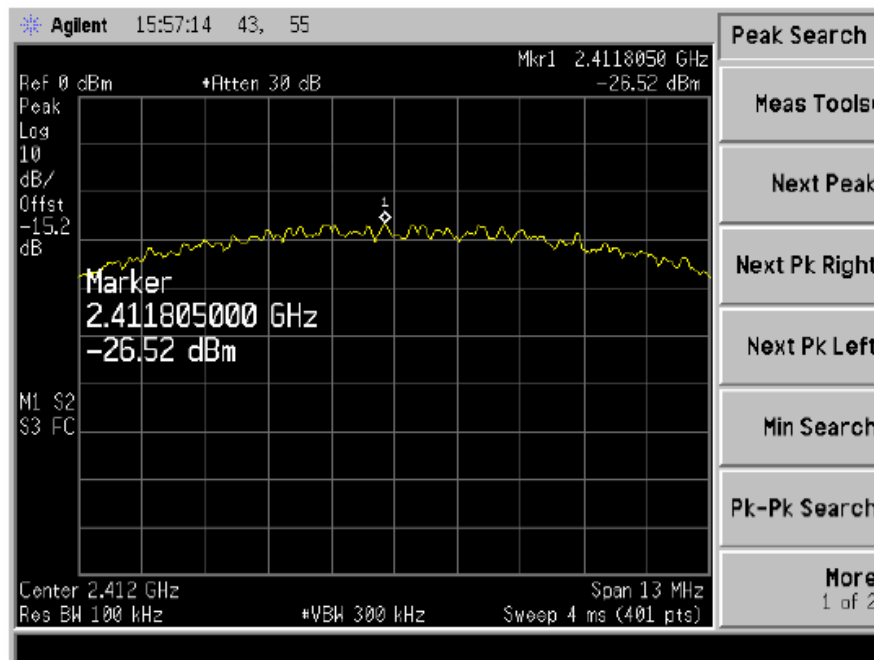

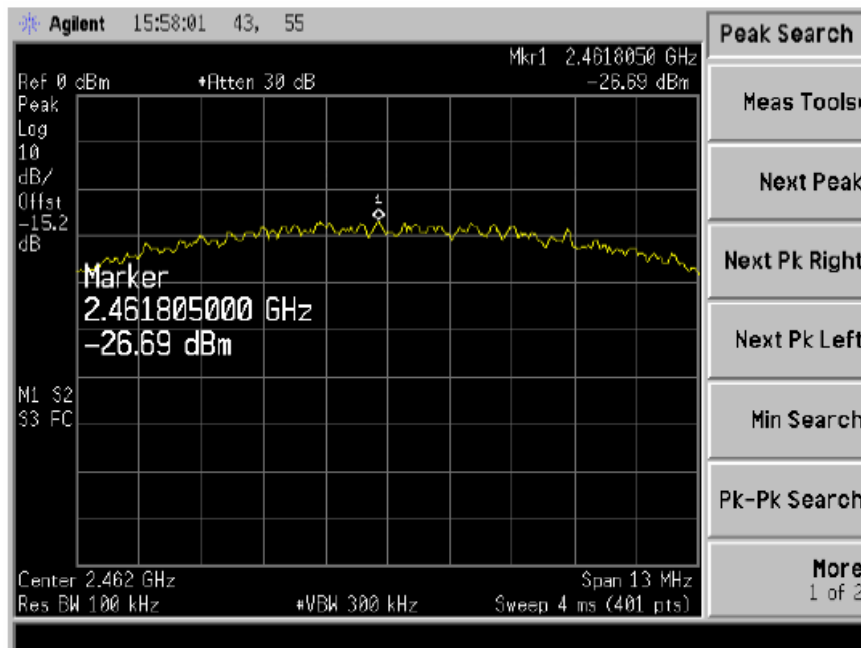
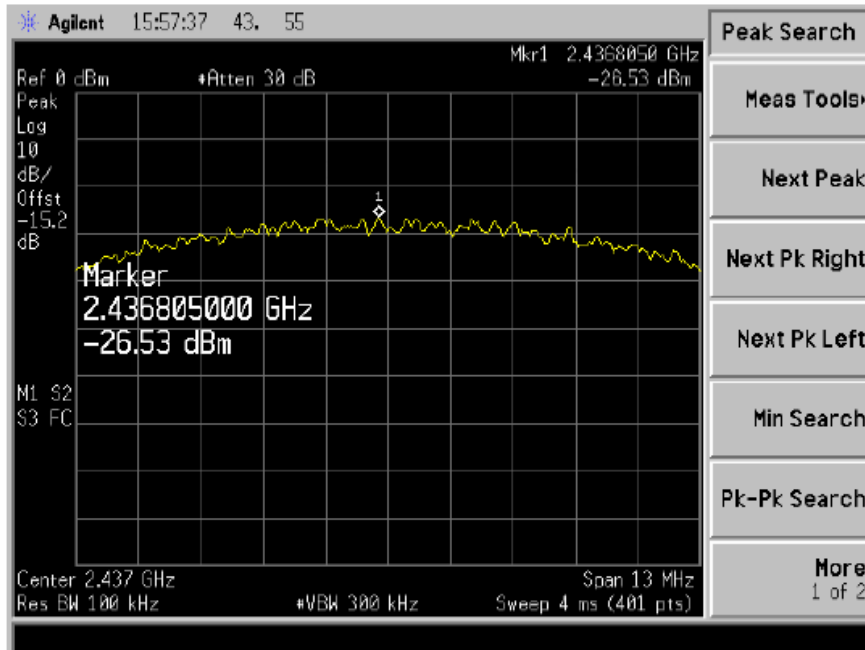

Spectrum Detector: PK Test Date : November 20, 2012
 Test By: Andy Temperature : 28°C
 Test Result: PASS Humidity : 65 %
 Operation Mode: 802.11 g

| Channel | Measurement Level (dBm) | Required Limit (dBm) | Result |
|---------|-------------------------|----------------------|--------|
| 1 | -33.58 | <8dBm | PASS |
| 6 | -33.48 | <8dBm | PASS |
| 11 | -34.15 | <8dBm | PASS |

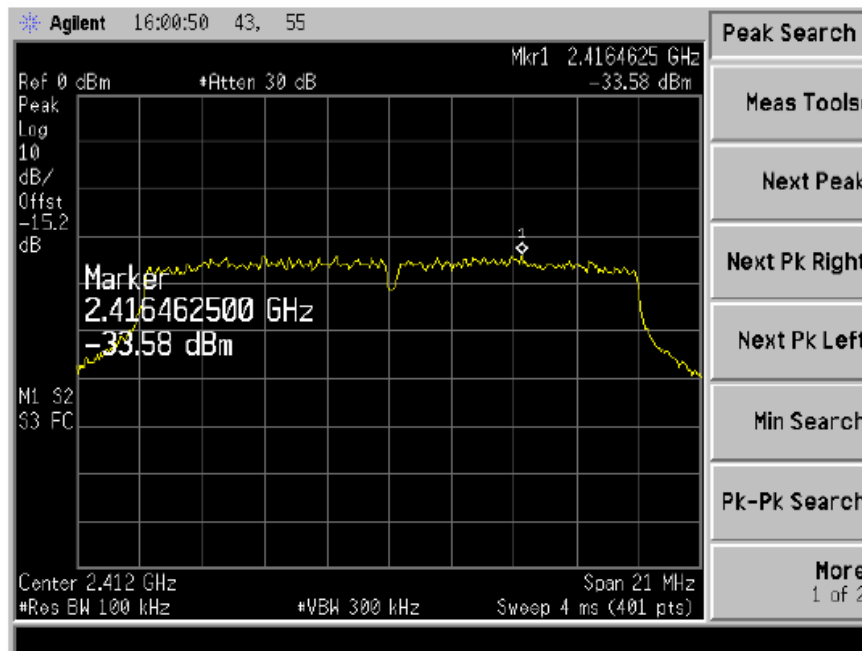

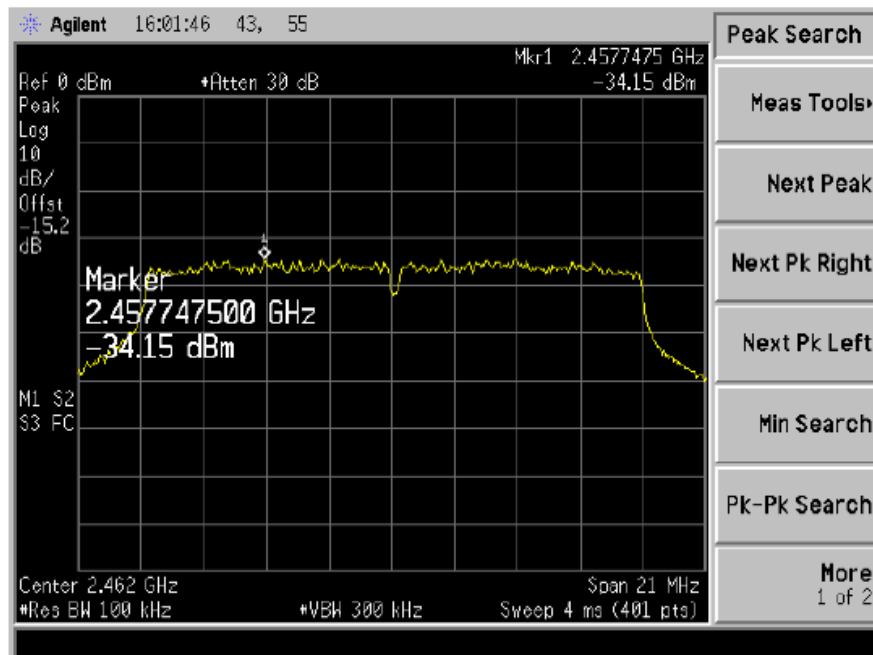
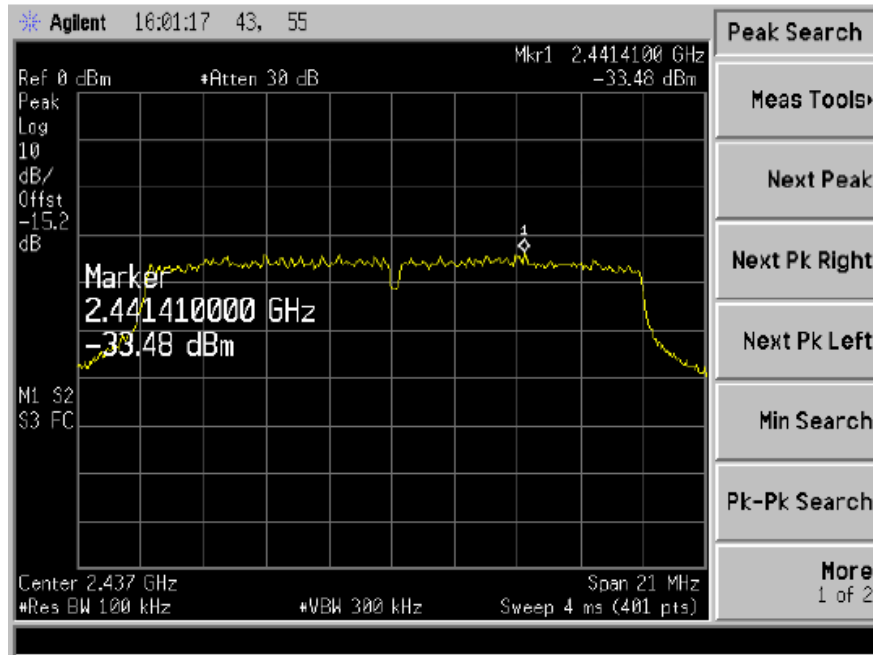

Spectrum Detector: PK Test Date : November 20, 2012
 Test By: Andy Temperature : 28°C
 Test Result: PASS Humidity : 65 %
 Operation Mode: 802.11 n

| Channel | Measurement Level (dBm) | Required Limit (dBm) | Result |
|---------|-------------------------|----------------------|--------|
| 1 | -33.99 | <8dBm | PASS |
| 6 | -34.52 | <8dBm | PASS |
| 11 | -34.12 | <8dBm | PASS |

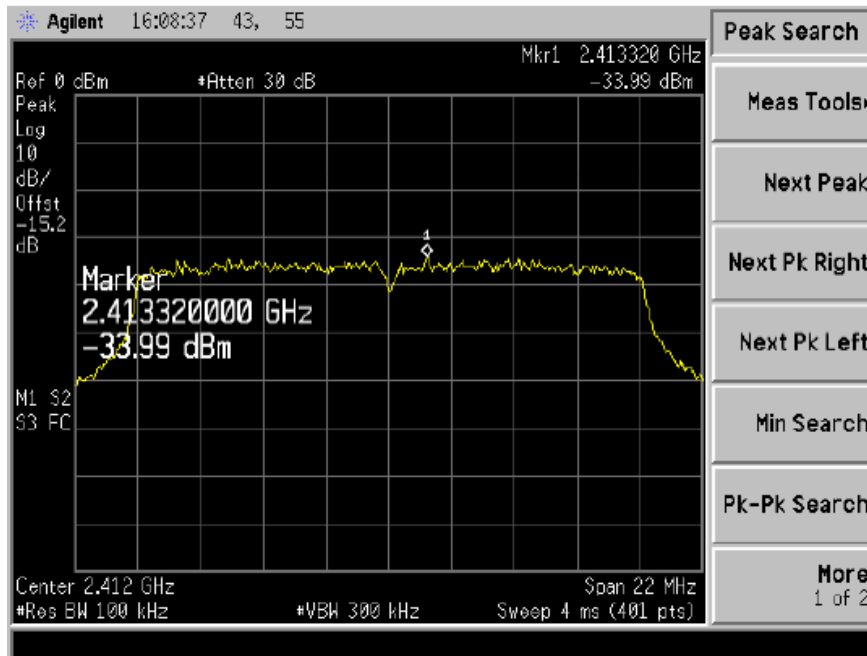

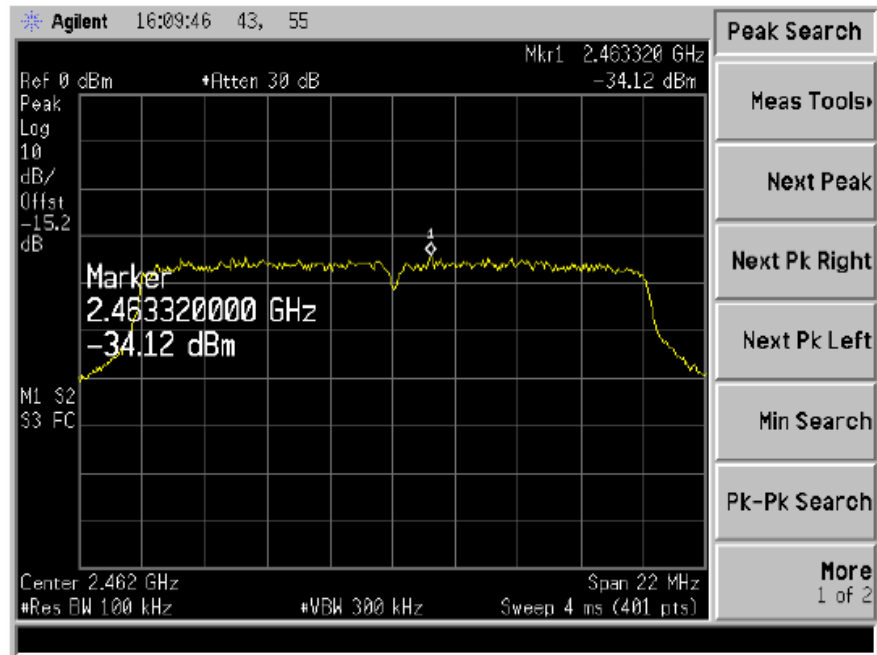
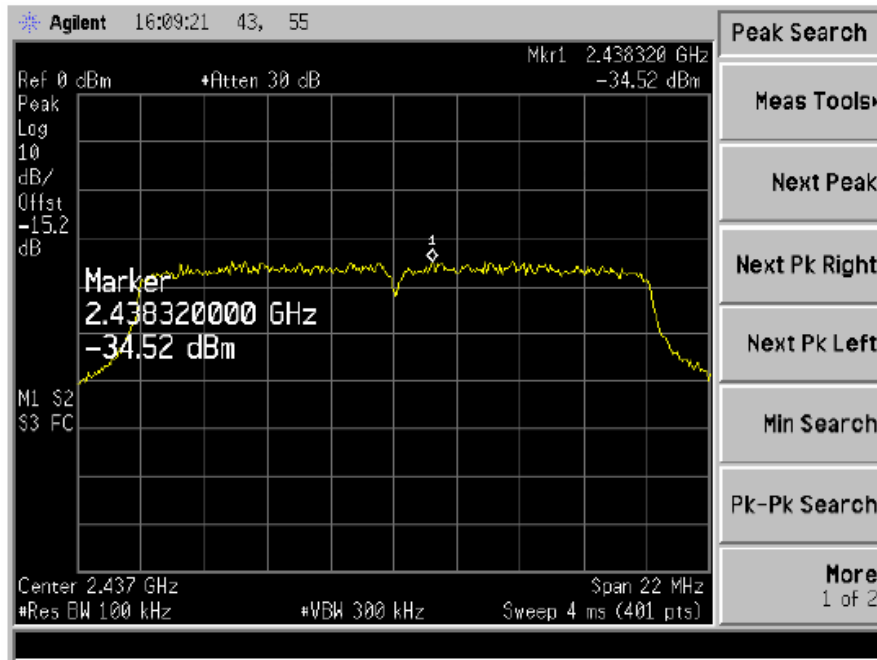

11. Antenna Port Emission

11.1 Test Equipment

| EQUIPMENT TYPE | MFR | MODEL NUMBER | SERIAL NUMBER | LAST CAL. | CAL DUE. |
|-------------------|---------|--------------|---------------|------------|------------|
| Spectrum Analyzer | Agilent | E4407B | 88156318 | 05/29/2012 | 05/28/2013 |

11.2 Measuring Instruments and Setting

The following table is the setting of spectrum analyzer.

| | |
|-------------------|----------|
| Spectrum analyzer | Setting |
| Attenuation | Auto |
| RB | 100kHz |
| VB | 300kHz |
| Detector | Peak |
| Trace | Max hold |

11.3 Test Procedures

The conducted spurious emissions were measured conducted using a spectrum analyzer at low, Middle, and high channels, the limit was determined by attenuation 20dB of the RF peak power output.

11.4 Block Diagram of Test setup

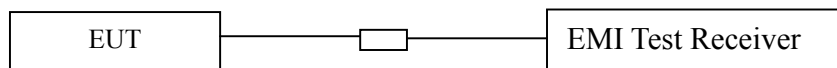

11.5 Test Result

PASS.

802.11b Low Channel 1

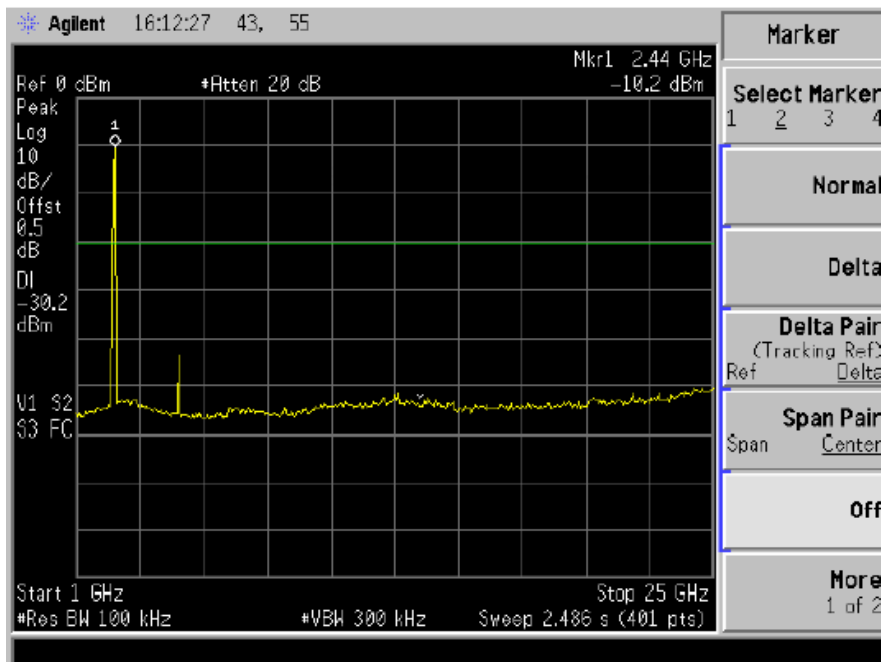
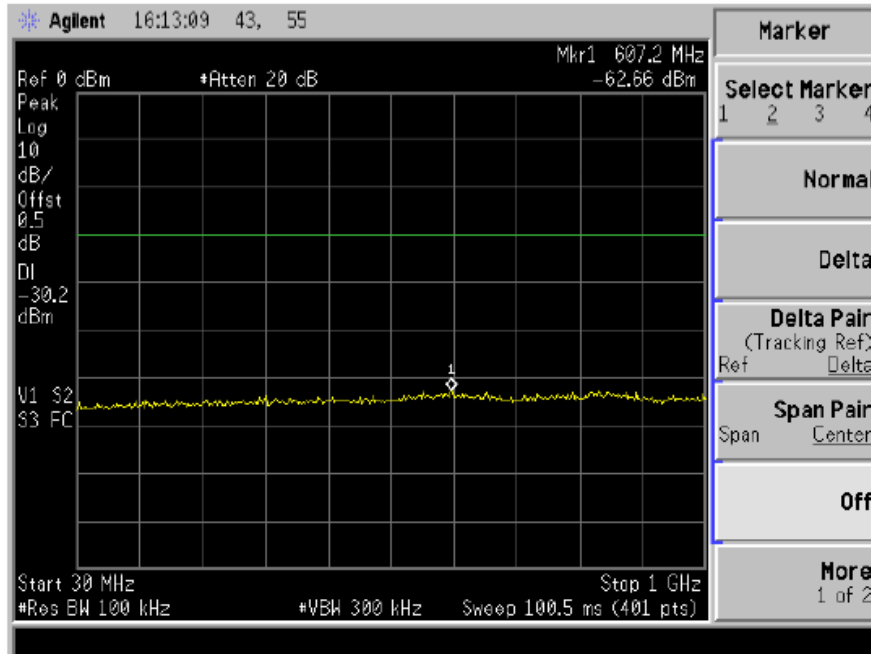

802.11b Mid Channel 6

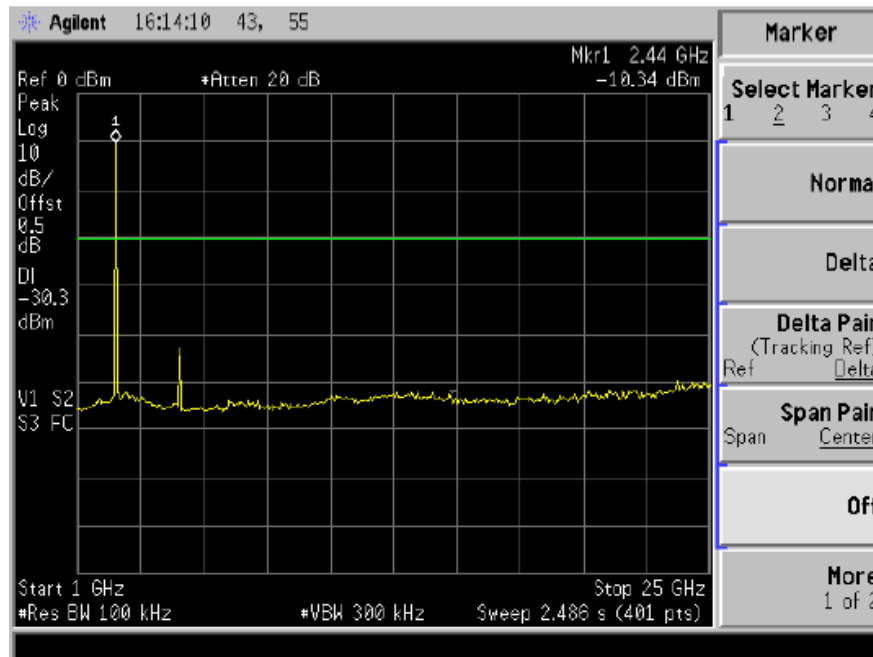
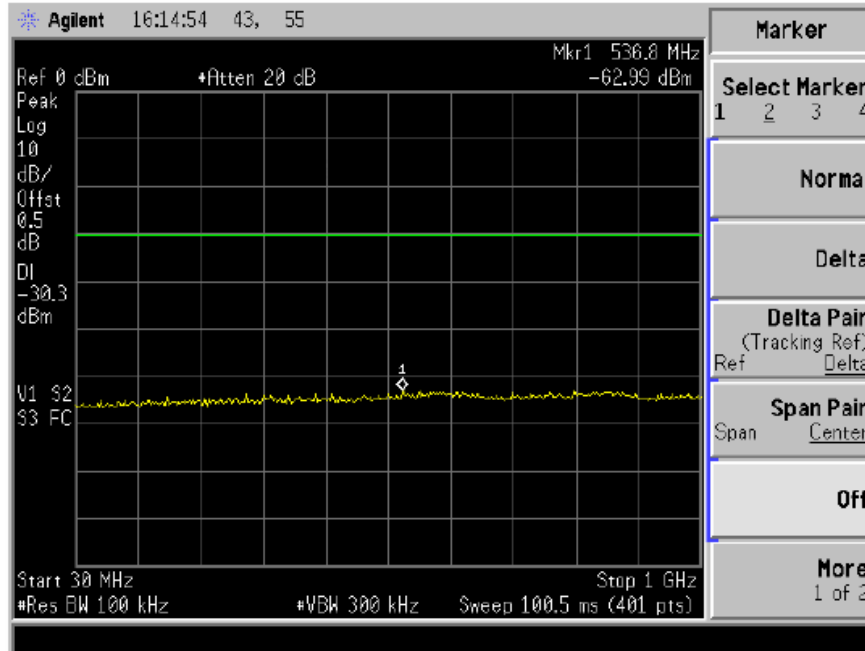

802.11b High Channel 11

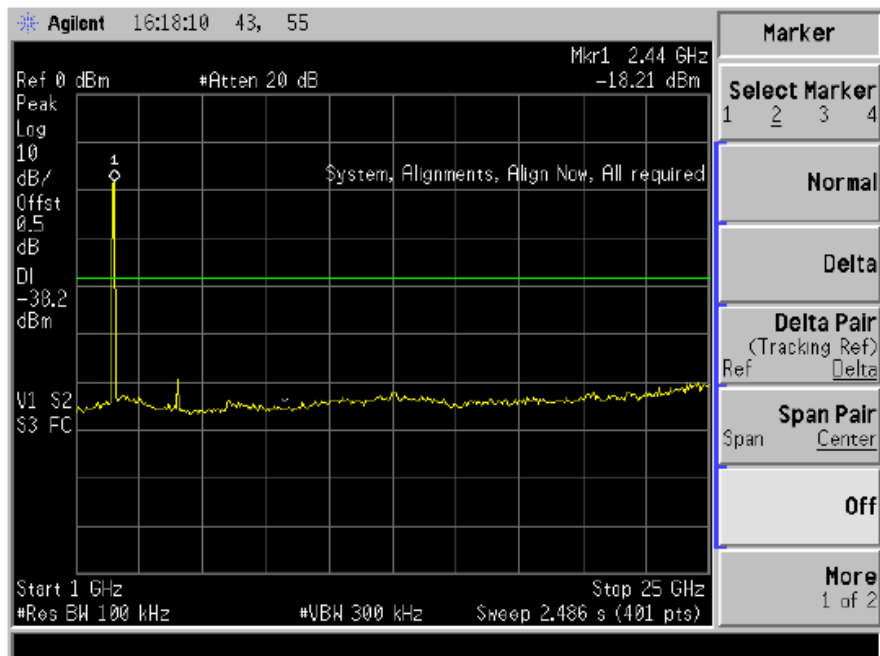
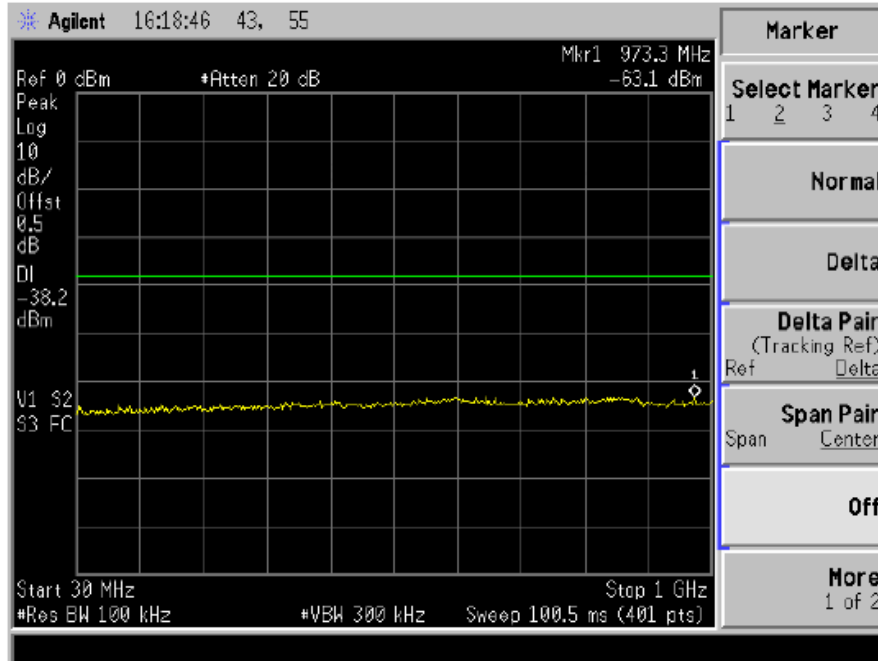

802.11g Low Channels 1

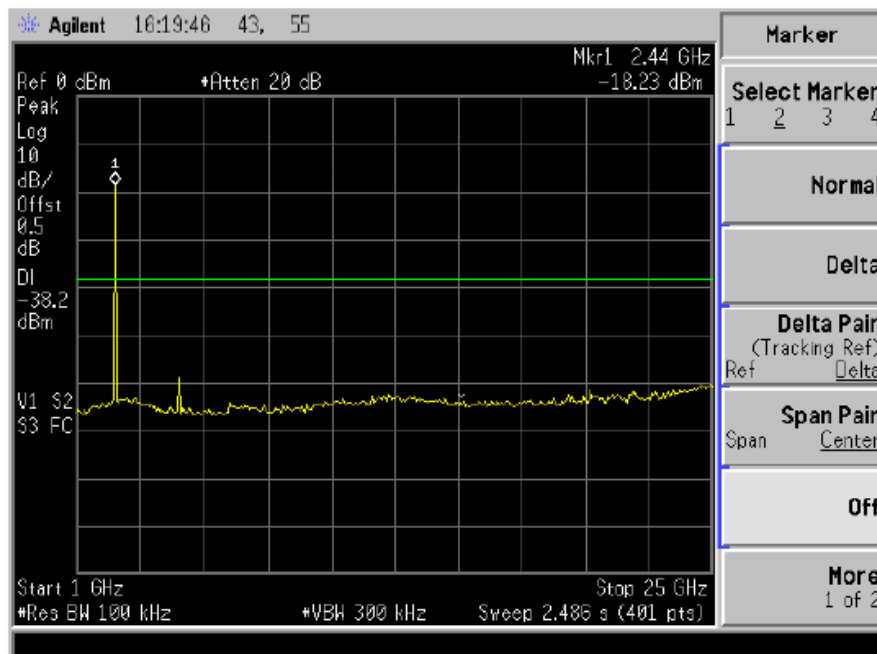
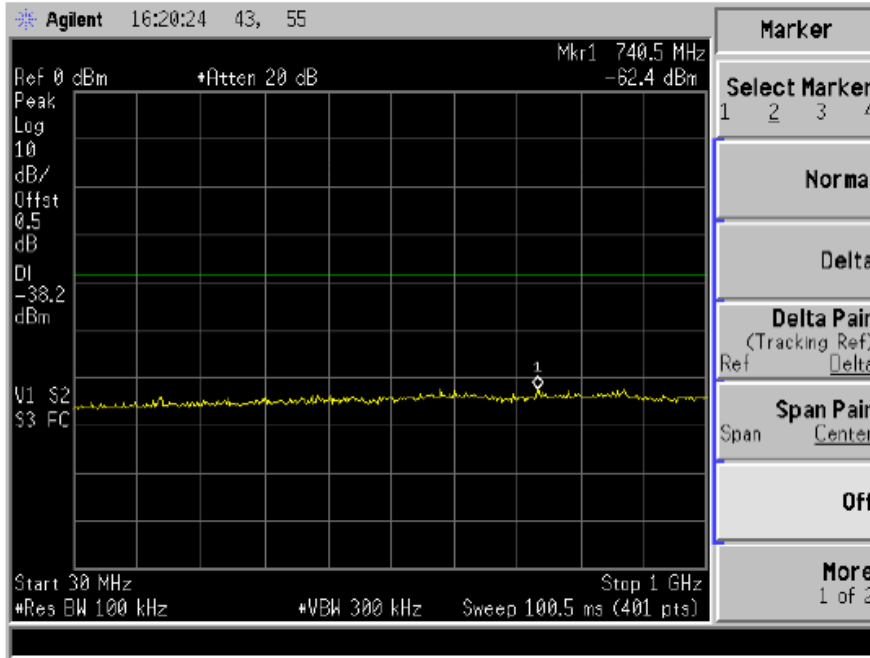

802.11g Mid Channel 6

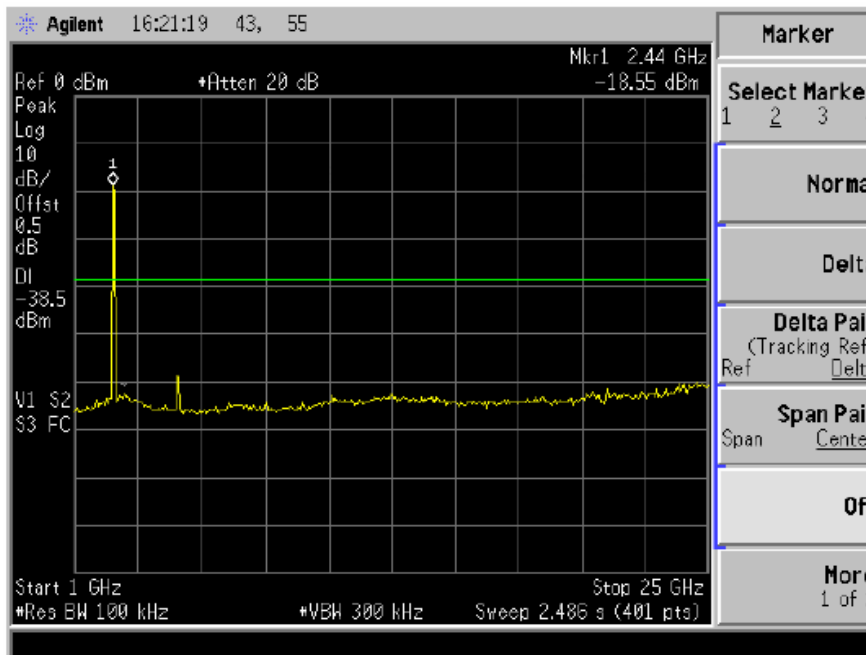
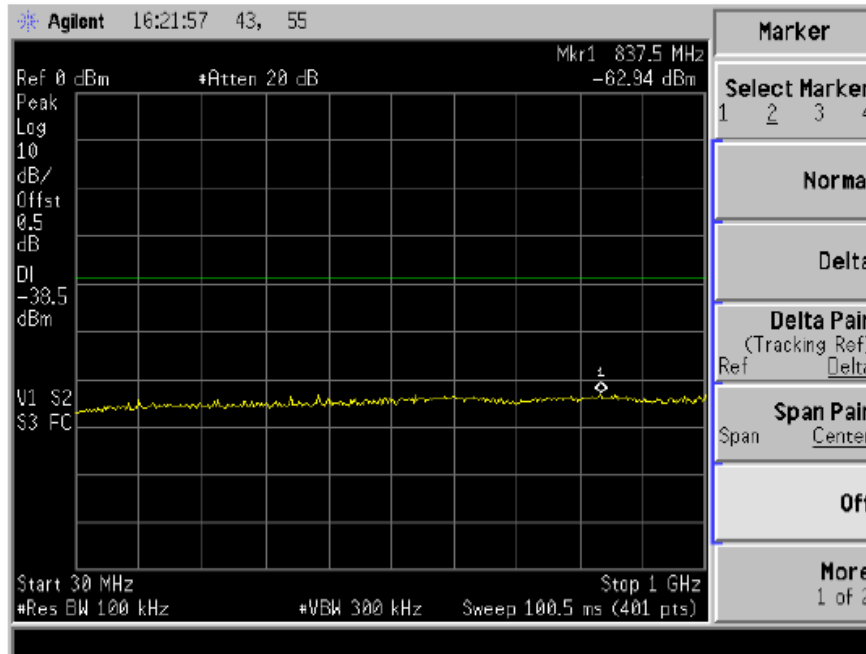

802.11g High Channel 11

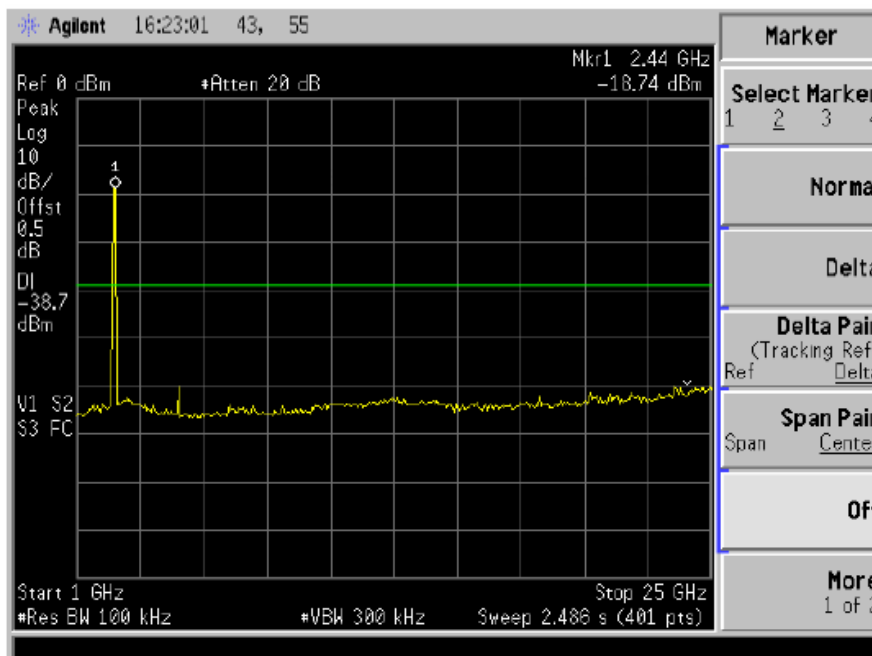
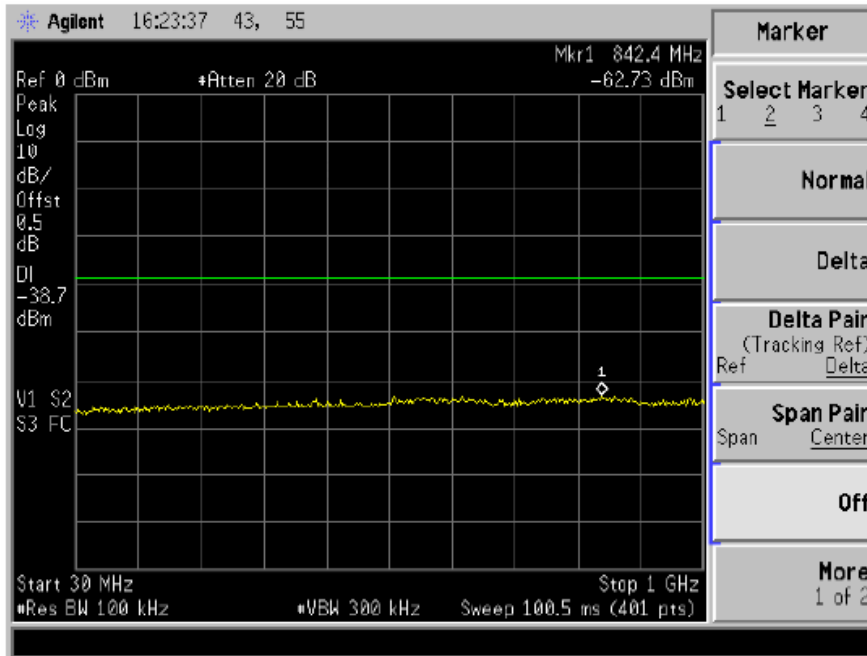

802.11n Low Channel 1

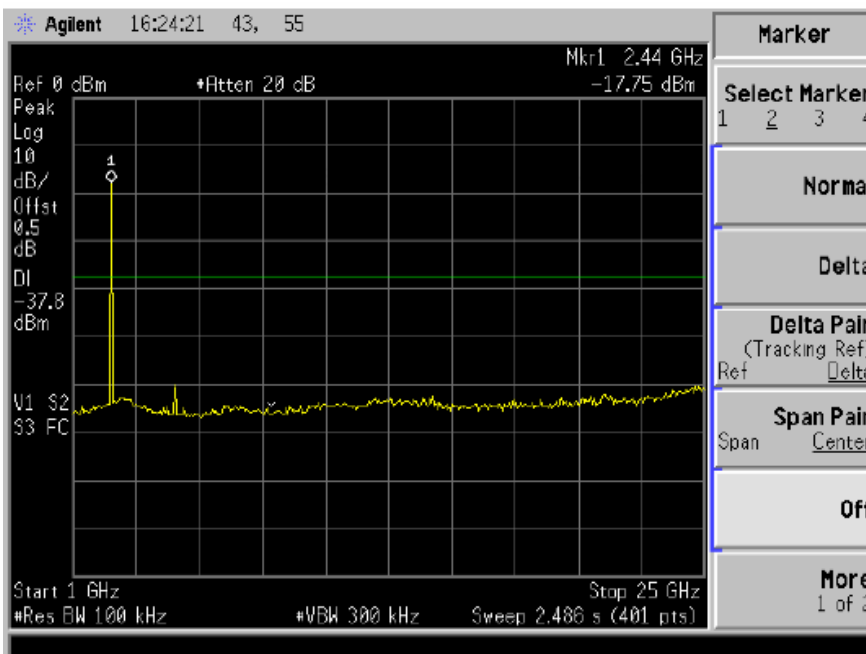
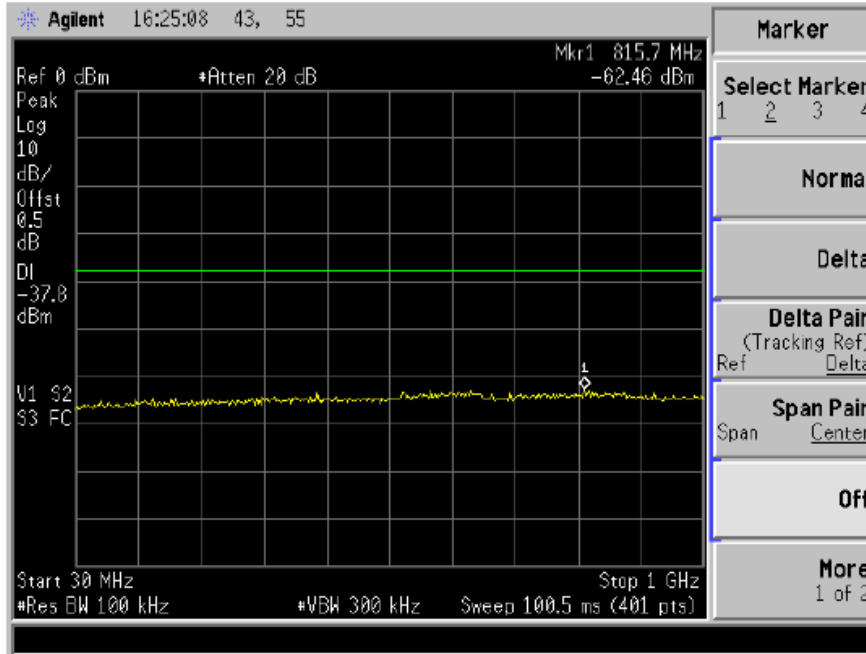

802.11n Channel 6

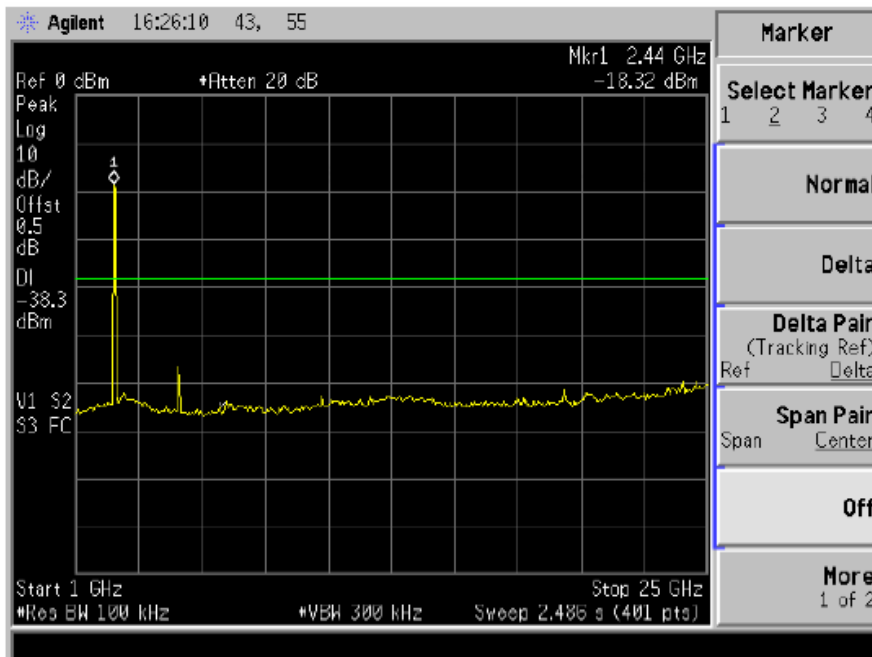
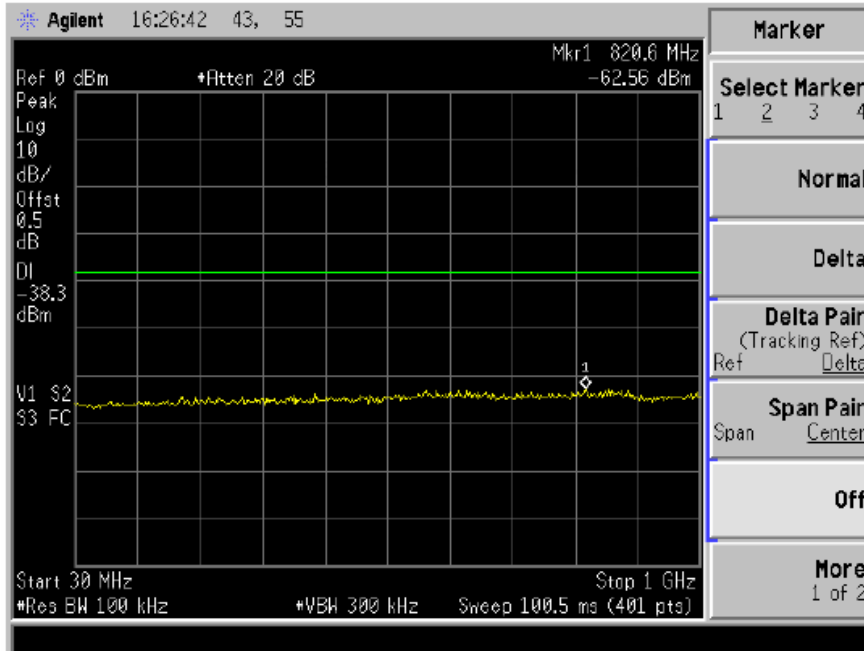

802.11n High Channel 11

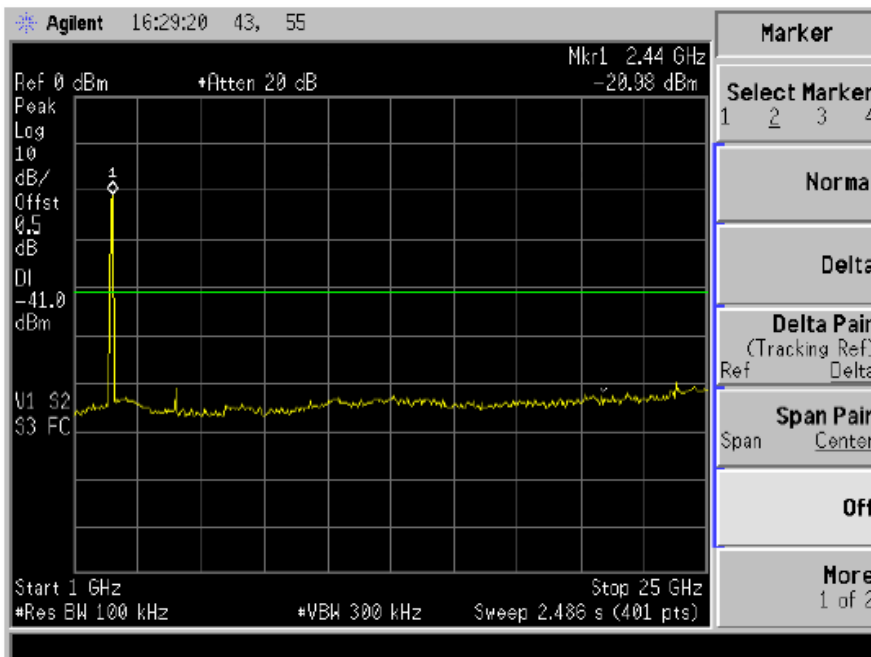
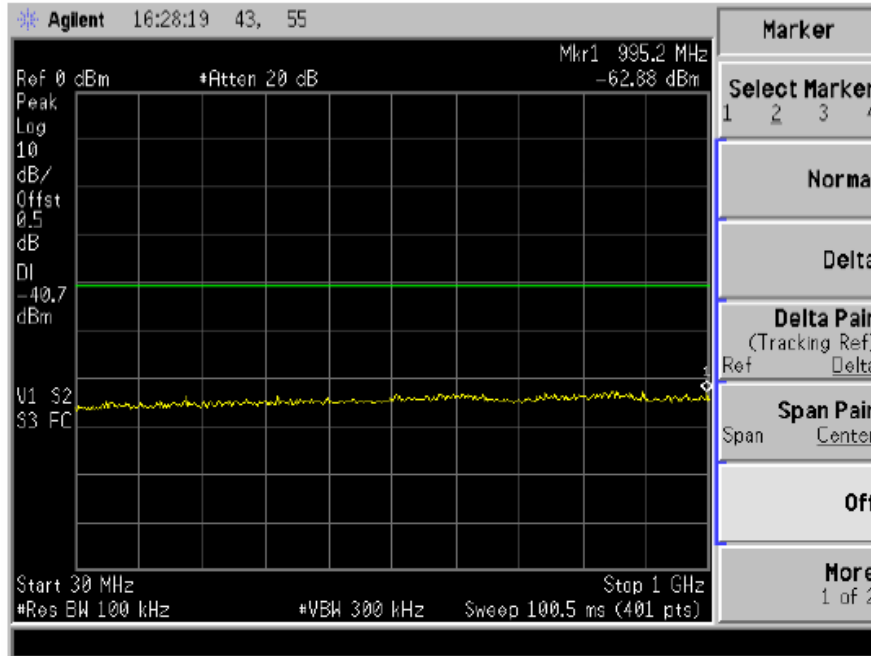

12. Antenna Application

12.1 Antenna Requirement

For intentional device, according to FCC 47 CFR Section 15.203, an intentional radiator shall be designed to ensure that no antenna other than that furnished by the responsible party shall be used with the device. And according to FCC 47 CFR Section 15.247 (b), if transmitting antennas of directional gain greater than 6dBi are used, the power shall be reduced by the amount in dB that the directional gain of the antenna exceeds 6dBi.

12.2 Result

The EUT'S antenna is PCB Antenna. The antenna's gain is 1.0dBi and meets the requirement.