

FCC 47 CFR PART 15 SUBPART C

CERTIFICATION TEST REPORT

For

Tablet PC

Model No.: Lenovo ideapad MIIX 300-10IBY, Lenovo ideapad MIIX 80NR,
Lenovo ideapad MIIX 300-10IBY xxxxxx, 80NR xxxxxx
(the dots "x" in the model name can be 0 to 9, A to Z, a to z, "-" or blank, for
marketing use)

FCC ID: S7JMIIX300

Trademark:Lenovo

REPORT NO.: ES150513119E1

ISSUE DATE: June 3, 2015

Prepared for

SHENZHEN YIFANG DIGITAL TECHNOLOGY CO., LTD.

Building NO.22,23, Fifth Region, Baiwangxin Industrial Park, Songbai Rd.,
Nanshan, Shenzhen518108, China

Prepared by

SHENZHEN EMTEK CO., LTD.

Bldg 69, Majialong Industry Zone, Nanshan District, Shenzhen,
Guangdong, China
TEL: 86-755-26954280
FAX: 86-755-26954282

Table of Contents

| | | |
|-----|---|----|
| 1 | TEST RESULT CERTIFICATION | 3 |
| 2 | EUT TECHNICAL DESCRIPTION | 4 |
| 3 | SUMMARY OF TEST RESULT | 6 |
| 4 | TEST METHODOLOGY | 7 |
| 4.1 | GENERAL DESCRIPTION OF APPLIED STANDARDS | 7 |
| 4.2 | MEASUREMENT EQUIPMENT USED | 7 |
| 4.3 | DESCRIPTION OF TEST MODES | 8 |
| 5 | FACILITIES AND ACCREDITATIONS | 9 |
| 5.1 | FACILITIES | 9 |
| 5.2 | LABORATORY ACCREDITATIONS AND LISTINGS | 9 |
| 6 | TEST SYSTEM UNCERTAINTY | 10 |
| 7 | SETUP OF EQUIPMENT UNDER TEST | 11 |
| 7.1 | RADIO FREQUENCY TEST SETUP 1 | 11 |
| 7.2 | RADIO FREQUENCY TEST SETUP 2 | 11 |
| 7.3 | CONDUCTED EMISSION TEST SETUP | 13 |
| 7.4 | BLOCK DIAGRAM CONFIGURATION OF TEST SYSTEM | 13 |
| 7.5 | SUPPORT EQUIPMENT | 13 |
| 8 | FREQUENCY HOPPING SYSTEM REQUIREMENTS | 14 |
| 8.1 | STANDARD APPLICABLE | 14 |
| 8.2 | EUT PSEUDORANDOM FREQUENCY HOPPING SEQUENCE | 14 |
| 8.3 | EQUAL HOPPING FREQUENCY USE | 15 |
| 8.4 | FREQUENCY HOPPING SYSTEM | 15 |
| 9 | TEST REQUIREMENTS | 16 |
| 9.1 | 20DB BANDWIDTH | 16 |
| 9.2 | CARRIER FREQUENCY SEPARATION | 22 |
| 9.3 | NUMBER OF HOPPING FREQUENCIES | 28 |
| 9.4 | AVERAGE TIME OF OCCUPANCY (DWELL TIME) | 30 |
| 9.5 | MAXIMUM PEAK CONDUCTED OUTPUT POWER | 33 |
| 9.6 | CONDUCTED SUPRIIOUS EMISSION | 39 |
| 9.7 | RADIATED SPURIOUS EMISSION | 46 |
| 9.8 | CONDUCTED EMISSION TEST | 67 |
| 9.9 | ANTENNA APPLICATION | 72 |

1 TEST RESULT CERTIFICATION

| | |
|----------------------|--|
| Applicant: | SHENZHEN YIFANG DIGITAL TECHNOLOGY CO., LTD. Building NO.22,23, Fifth Region, Baiwangxin Industrial Park, Songbai Rd., Nanshan, Shenzhen518108, China |
| Manufacturer: | Lenovo PC HK Limited 23/F, Lincoln House, Taikoo Place, 979 King's Road, Quarry Bay, Hong Kong |
| Product Description: | Tablet PC |
| Model Number: | Lenovo ideapad MIIX 300-10IBY,Lenovo ideapad MIIX 80NR,Lenovo ideapad MIIX 300-10IBY xxxxxx, 80NR xxxxxx(the dots "x" in the model name can be 0 to 9, A to Z, a to z, "-"or blank, for marketing use) (Note: These models are identical in circuitry and electrical, mechanical and physical construction; the only differences are the silk-screen, color and model no. for trading purpose. We prepare Lenovo ideapad MIIX 300-10IBY for test. and the worst result recorded in the report.) |
| File Number: | ES150513119E1 |
| Date of Test: | May 14, 2015 to June 3, 2015 |

Measurement Procedure Used:

| APPLICABLE STANDARDS | |
|---|-------------|
| STANDARD | TEST RESULT |
| FCC 47 CFR Part 2, Subpart J:2014 FCC 47 CFR Part 15, Subpart C:2014 | PASS |

The above equipment was tested by SHENZHEN EMTEK CO., LTD. The test data, data evaluation, test procedures, and equipment configurations shown in this report were made in accordance with the procedures given in ANSI C63.10 (2013) and the energy emitted by the sample EUT tested as described in this report is in compliance with the requirements of FCC Rules Part 2 and Part 15.247

The test results of this report relate only to the tested sample identified in this report

Date of Test : May 14, 2015 to June 3, 2015

Prepared by : 
Jack Li/Editor

Reviewer : 
Joe Xia/Supervisor

Approve & Authorized Signer : 
Lisa Wang/Manager

2 EUT TECHNICAL DESCRIPTION

| Characteristics | Description |
|-------------------------------|---|
| Device Type: | Portable device |
| Data Rate | 1Mbps for BT v2.0/v2.1/v3.0 BR GFSK modulation 2Mbps for BT v2.0/v2.1/v3.0 EDR pi/4-DQPSK modulation 3Mbps for BT v2.0/v2.1/v3.0 EDR 8DPSK modulation |
| Modulation: | GFSK modulation for BT v2.0/v2.1/v3.0 BR(1Mbps) pi/4-DQPSK modulation for BT v2.0/v2.1/v3.0 EDR(2Mbps) 8DPSK modulation for BT v2.0/v2.1/v3.0 EDR (3Mbps) |
| Operating Frequency Range(s): | 2402-2480MHz for BT v2.0 BR /2.0+EDR; 2402-2480MHz for BT v2.1 BR /2.1+EDR; 2402-2480MHz for BT v3.0 BR /3.0+ EDR; |
| Number of Channels: | 79 channels for BT v2.0/v2.1/v3.0 BR; 79 channels for BT v2.0/v2.1/v3.0 EDR; |
| Transmit Power Max: | 10.599dBm for BT v2.0/v2.1/v3.0 EDR; 9.264dBm for BT v2.0/v2.1/v3.0 BR; |
| Antenna Type : | PIFA Antenna |
| Antenna Gain: | 2.5dBi |
| Power supply: | <input checked="" type="checkbox"/> DC supply: DC 3.7V internal rechargeable lithium battery or DC 5V from AC Adapter |
| | <input checked="" type="checkbox"/> Adapter supply: Model: HKC0125024-2C INPUT: 100-240V~ 50/60Hz 0.5A OUTPUT: DC 5V 2.4A |
| Temperature Range | 0°C ~ +40°C |
| Product Software Version: | Windows 8.1 |
| Product Hardware Version: | M1205BFP-MB-V1.4 |
| Radio Software Version: | 802.11b/g/n, Bluetooth |
| Radio Hardware Version: | RTL8723BS |
| RF power setting in TEST SW: | Maximum power |

Note: for more details, please refer to the User's manual of the EUT.

3 SUMMARY OF TEST RESULT

| FCC Part Clause | Test Parameter | Verdict | Remark |
|-----------------------------|--|---------|--------|
| 15.247(a)(1) | 20 dB Bandwidth | PASS | |
| 15.247(a)(1) | Carrier Frequency Separation | PASS | |
| 15.247(a)(1) | Number of Hopping Frequencies | PASS | |
| 15.247(a)(1) | Average Time of Occupancy (Dwell Time) | PASS | |
| 15.247(b)(1) | Maximum Peak Conducted Output Power | PASS | |
| 15.247(c) | Conducted Spurious Emissions | PASS | |
| 15.247(d) 15.209 | Radiated Spurious Emissions | PASS | |
| 15.207 | Conducted Emission | PASS | |
| 15.247(b) | Antenna Application | PASS | |
| NOTE1: N/A (Not Applicable) | | | |

RELATED SUBMITTAL(S) / GRANT(S):

This submittal(s) (test report) is intended for FCC ID: S7JMIX300 filing to comply with Section 15.247 of the FCC Part 15, Subpart C Rules.

The FHSS system is compliance with Subpart B is authorized under a DOC procedure

4 TEST METHODOLOGY

4.1 GENERAL DESCRIPTION OF APPLIED STANDARDS

According to its specifications, the EUT must comply with the requirements of the following standards:
 FCC 47 CFR Part 2, Subpart J
 FCC 47 CFR Part 15, Subpart C
 DA 00-705

4.2 MEASUREMENT EQUIPMENT USED

4.2.1 Conducted Emission Test Equipment

| EQUIPMENT TYPE | MFR | MODEL NUMBER | SERIAL NUMBER | LAST CAL. |
|--------------------|-----------------|--------------|---------------|------------|
| Test Receiver | Rohde & Schwarz | ESCS30 | 828985/018 | 05/16/2015 |
| L.I.S.N. | Schwarzbeck | NNLK8129 | 8129203 | 05/16/2015 |
| 50Ω Coaxial Switch | Anritsu | MP59B | M20531 | N/A |
| Pulse Limiter | Rohde & Schwarz | ESH3-Z2 | 100006 | 05/16/2015 |
| Voltage Probe | Rohde & Schwarz | TK9416 | N/A | 05/16/2015 |
| I.S.N | Rohde & Schwarz | ENY22 | 1109.9508.02 | 05/16/2015 |

4.2.2 Radiated Emission Test Equipment

| EQUIPMENT TYPE | MFR | MODEL NUMBER | SERIAL NUMBER | LAST CAL. |
|-------------------|-----------------|--------------|---------------|------------|
| EMI Test Receiver | Rohde & Schwarz | ESU | 1302.6005.26 | 05/16/2015 |
| Pre-Amplifier | HP | 8447D | 2944A07999 | 05/16/2015 |
| Bilog Antenna | Schwarzbeck | VULB9163 | 142 | 05/16/2015 |
| Loop Antenna | ARA | PLA-1030/B | 1029 | 05/16/2015 |
| Horn Antenna | Schwarzbeck | BBHA 9170 | BBHA9170399 | 05/16/2015 |
| Horn Antenna | Schwarzbeck | BBHA 9120 | D143 | 05/16/2015 |
| Cable | Schwarzbeck | AK9513 | ACRX1 | 05/16/2015 |
| Cable | Rosenberger | N/A | FP2RX2 | 05/16/2015 |
| Cable | Schwarzbeck | AK9513 | CRPX1 | 05/16/2015 |
| Cable | Schwarzbeck | AK9513 | CRRX2 | 05/16/2015 |

4.2.3 Radio Frequency Test Equipment

| EQUIPMENT TYPE | MFR | MODEL NUMBER | SERIAL NUMBER | LAST CAL. |
|-------------------|---------|--------------|---------------|------------|
| Spectrum Analyzer | Agilent | E4407B | 88156318 | 05/16/2015 |
| Power meter | Anritsu | ML2495A | 0824006 | 05/16/2015 |
| Power sensor | Anritsu | MA2411B | 0738172 | 05/16/2015 |
| Signal Analyzer | Agilent | N9010A | My53470879 | 05/16/2015 |

Remark: Each piece of equipment is scheduled for calibration once a year.

4.3 DESCRIPTION OF TEST MODES

The EUT has been tested under its typical operating condition.

The EUT configuration for testing is installed on RF field strength measurement to meet the Commissions requirement and operating in a manner which intends to maximize its emission characteristics in a continuous normal application.

The Transmitter was operated in the normal operating mode. The TX frequency was fixed which was for the purpose of the measurements.

Test of channel included the lowest and middle and highest frequency to perform the test, then record on this report.

Those data rates (1Mbps for Bluetooth v2.0 /v2.1/v3.0 BR GFSK modulation; 2Mbps for Bluetooth v2.0/v2.1 /v3.0 EDR pi/4-DQPSK modulation; 3Mbps for Bluetooth v2.0/v2.1 /v3.0 EDR 8DPSK modulation) were used for all test.

Pre-defined engineering program for regulatory testing used to control the EUT for staying in continuous transmitting and receiving mode is programmed.

The EUT was pretested with 3 orientations placed on the table for the radiated emission measurement –X, Y, and Z-plane. The Y-plane results were found as the worst case and were shown in this report.

Frequency and Channel list for Bluetooth v2.0 /v2.1/v3.0:

| Channel | Frequency (MHz) | Channel | Frequency (MHz) | Channel | Frequency (MHz) |
|---------|-----------------|---------|-----------------|---------|-----------------|
| 0 | 2402 | 39 | 2441 | ... | ... |
| 1 | 2403 | 40 | 2442 | 76 | 2478 |
| 2 | 2404 | 41 | 2443 | 77 | 2479 |
| ... | ... | ... | ... | 78 | 2480 |

Note: $f_c = 2402\text{MHz} + k \times 1\text{MHz}$ $k=0$ to 78

Test Frequency and channel for Bluetooth v2.0 /v2.1/v3.0:

| Lowest Frequency | | Middle Frequency | | Highest Frequency | |
|------------------|-----------------|------------------|-----------------|-------------------|-----------------|
| Channel | Frequency (MHz) | Channel | Frequency (MHz) | Channel | Frequency (MHz) |
| 0 | 2402 | 39 | 2441 | 78 | 2480 |

5 FACILITIES AND ACCREDITATIONS

5.1 FACILITIES

All measurement facilities used to collect the measurement data are located at

Bldg 69, Majialong Industry Zone District, Nanshan District, Shenzhen, China

The sites are constructed in conformance with the requirements of ANSI C63.7, ANSI C63.10 and CISPR Publication 22.

5.2 LABORATORY ACCREDITATIONS AND LISTINGS

Site Description

- EMC Lab.
- : Accredited by CNAS, 2013.10.29
The certificate is valid until 2016.10.28
The Laboratory has been assessed and proved to be in compliance with CNAS-CL01: 2006(identical to ISO/IEC17025: 2005)
The Certificate Registration Number is L2291
 - : Accredited by TUV Rheinland Shenzhen, 2010.5.25
The Laboratory has been assessed according to the requirements ISO/IEC 17025.
 - : Accredited by FCC, October 28, 2010
The Certificate Registration Number is 406365.
 - : Accredited by FCC, February 28, 2013
The Certificate Registration Number is 709623.
 - : Accredited by Industry Canada, May 24, 2008
The Certificate Registration Number is 4480A-2

6 TEST SYSTEM UNCERTAINTY

The following measurement uncertainty levels have been estimated for tests performed on the apparatus:

| Parameter | Uncertainty |
|--------------------------------|-------------------------|
| Radio Frequency | $\pm 1 \times 10^{-5}$ |
| Maximum Peak Output Power Test | $\pm 1.0\text{dB}$ |
| Conducted Emissions Test | $\pm 2.0\text{dB}$ |
| Radiated Emission Test | $\pm 2.0\text{dB}$ |
| Occupied Bandwidth Test | $\pm 1.0\text{dB}$ |
| Band Edge Test | $\pm 3\text{dB}$ |
| All emission, radiated | $\pm 3\text{dB}$ |
| Antenna Port Emission | $\pm 3\text{dB}$ |
| Temperature | $\pm 0.5^\circ\text{C}$ |
| Humidity | $\pm 3\%$ |

Measurement Uncertainty for a level of Confidence of 95%

7 SETUP OF EQUIPMENT UNDER TEST

7.1 RADIO FREQUENCY TEST SETUP 1

The Bluetooth v2.0 /v2.1/v3.0 component's antenna ports(s) of the EUT are connected to the measurement instrument per an appropriate attenuator. The EUT is controlled by PC/software to emit the specified signals for the purpose of measurements.

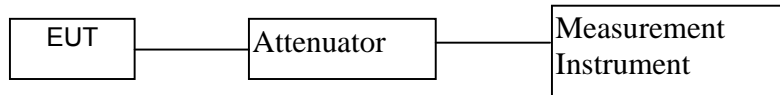

7.2 RADIO FREQUENCY TEST SETUP 2

The test site semi-anechoic chamber has met the requirement of NSA tolerance 4 dB according to the standards: ANSI C63.10-2013. The test distance is 3m. The setup is according to the requirements in Section 13.1.4.1 of ANSI C63.10-2013 and CAN/CSA-CEI/IEC CISPR 22.

The maximal emission value is acquired by adjusting the antenna height, polarisation and turntable azimuth. Normally, the height range of antenna is 1 m to 4 m, the azimuth range of turntable is 0° to 360°, and the receive antenna has two polarizations Vertical (V) and Horizontal (H).

Below 1000MHz:

The EUT is placed on a turntable 0.8 meters above the ground in the chamber, 3 meter away from the antenna (loop antenna). The Antenna should be positioned with its plane vertical at the specified distance from the EUT and rotated about its vertical axis for maximum response at each azimuth about the EUT. The center of the loop shall be 1 m above the ground. For certain applications, the loop antenna plane may also need to be positioned horizontally at the specified distance from the EUT.

Above 1000MHz:

The EUT is placed on a turntable 1.5 meters above the ground in the chamber, 3 meter away from the antenna. The maximal emission value is acquired by adjusting the antenna height, polarisation and turntable azimuth. Normally, the height range of antenna is 1 m to 4 m, the azimuth range of turntable is 0° to 360°, and the receive antenna has two polarizations Vertical (V) and Horizontal (H).

(a) Radiated Emission Test Set-Up, Frequency Below 30MHz

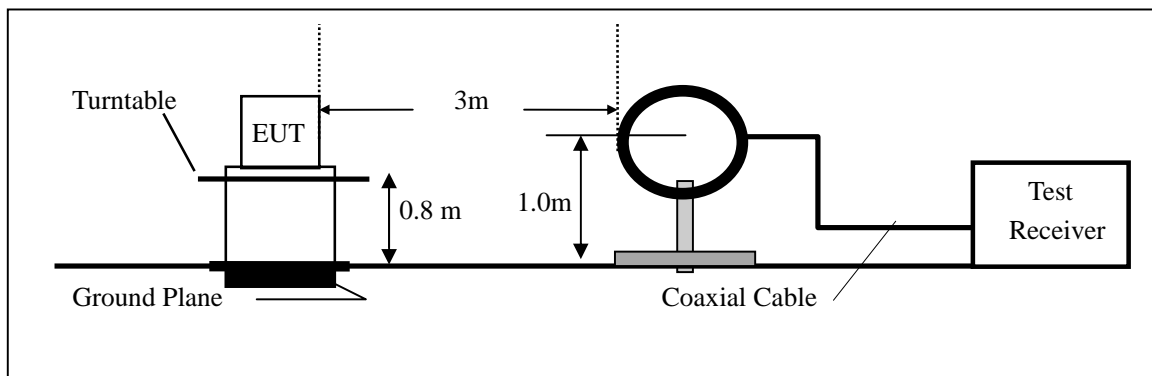

(b) Radiated Emission Test Set-Up, Frequency Below 1000MHz

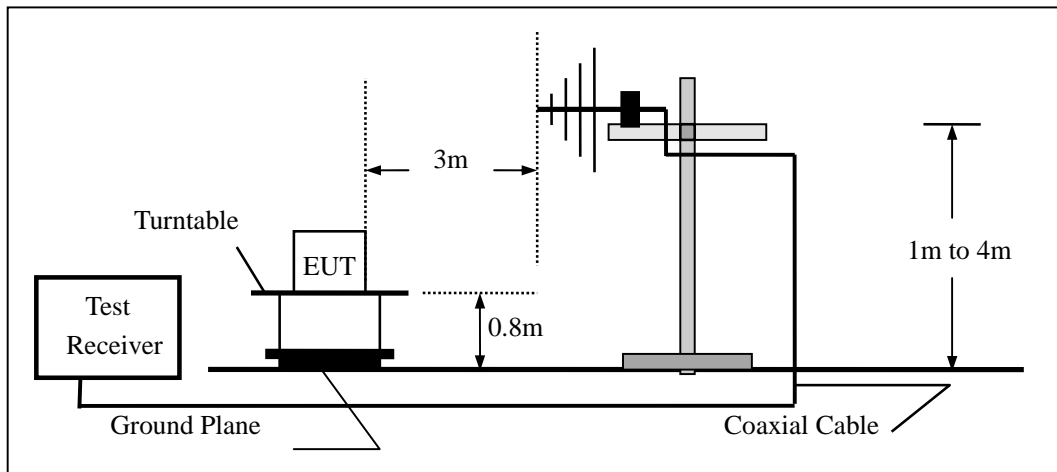

(c) Radiated Emission Test Set-Up, Frequency above 1000MHz

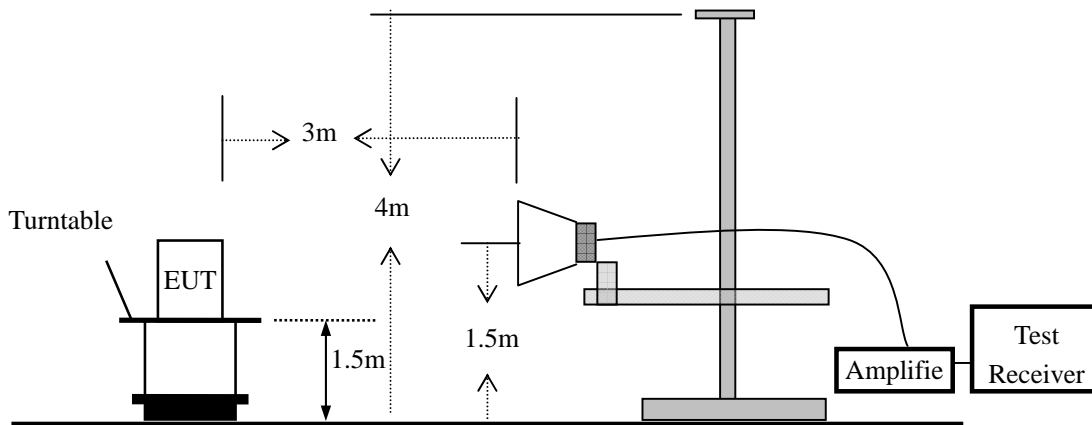

7.3 CONDUCTED EMISSION TEST SETUP

The mains cable of the EUT (Tablet PC) must be connected to LISN. The LISN shall be placed 0.8 m from the boundary of EUT and bonded to a ground reference plane for LISN mounted on top of the ground reference plane. This distance is between the closest points of the LISN and the EUT. All other units of the EUT and associated equipment shall be at least 0.8m from the LISN.

Ground connections, where required for safety purposes, shall be connected to the reference ground point of the LISN and, where not otherwise provided or specified by the manufacturer, shall be of same length as the mains cable and run parallel to the mains connection at a separation distance of not more than 0.1 m.

According to the requirements in Section 13.1.4.1 of ANSI C63.10-2013 Conducted emissions from the EUT measured in the frequency range between 0.15 MHz and 30 MHz using CISPR Quasi-Peak and average detector mode.

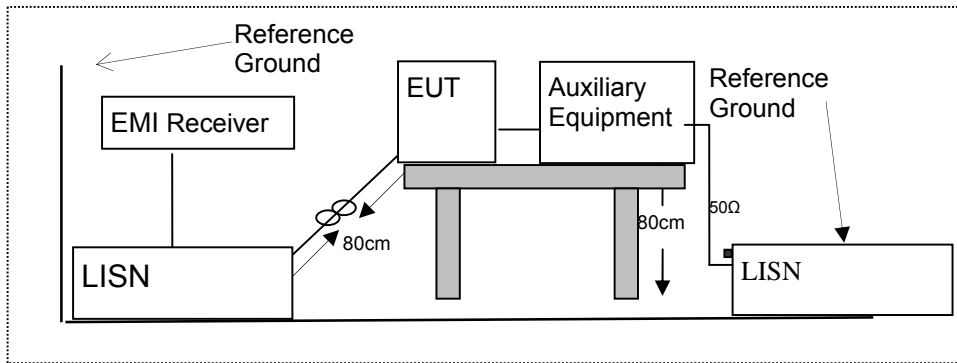

7.4 BLOCK DIAGRAM CONFIGURATION OF TEST SYSTEM

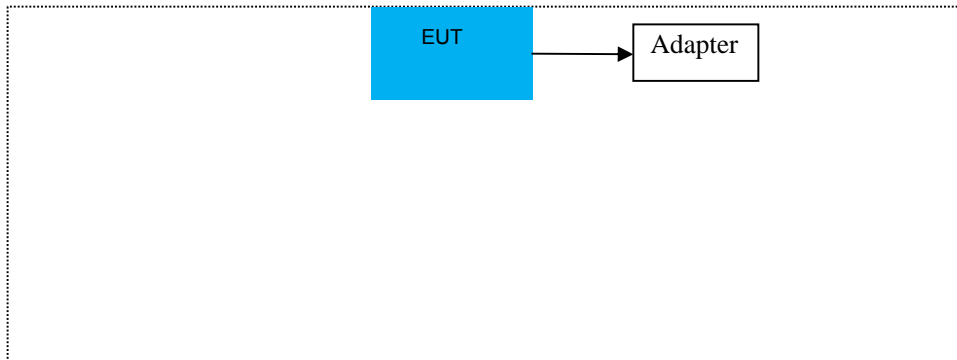

7.5 SUPPORT EQUIPMENT

| Item | Equipment | Mfr/Brand | Model/Type No. | FCC ID | Note |
|------|-----------|-----------|-------------------------------|------------|------|
| 1. | Tablet PC | Lenovo | Lenovo ideapad MIIX 300-10IBY | S7JMIIX300 | EUT |
| | | | | | |
| | | | | | |
| | | | | | |

Notes:

1. All the equipment/cables were placed in the worst-case configuration to maximize the emission during the test.
2. Grounding was established in accordance with the manufacturer's requirements and conditions for the intended use.

8 FREQUENCY HOPPING SYSTEM REQUIREMENTS

8.1 Standard Applicable

According to FCC Part 15.247(a)(1), The system shall hop to channel frequencies that are selected at the system hopping rate from a pseudo randomly ordered list of hopping frequencies. Each frequency must be used equally on the average by each transmitter. The system receivers shall have input bandwidths that match the hopping channel bandwidths of their corresponding transmitters and shall shift frequencies in synchronization with the transmitted signals.

(g) Frequency hopping spread spectrum systems are not required to employ all available hopping channels during each transmission. However, the system, consisting of both the transmitter and the receiver, must be designed to comply with all of the regulations in this section should the transmitter be presented with a continuous data (or information) stream. In addition, a system employing short transmission bursts must comply with the definition of a frequency hopping system and must distribute its transmissions over the minimum number of hopping channels specified in this section.

(h) The incorporation of intelligence within a frequency hopping spread spectrum system that permits the system to recognize other users within the spectrum band so that it individually and independently chooses and adapts its hopsets to avoid hopping on occupied channels is permitted. The coordination of frequency hopping systems in any other manner for the express purpose of avoiding the simultaneous occupancy of individual hopping frequencies by multiple transmitters is not permitted.

8.2 EUT Pseudorandom Frequency Hopping Sequence

The pseudorandom sequence may be generated in a nine-stage shift register whose 5th and 9th stage outputs are added in a modulo-two addition stage, and the result is fed back to the input of the first stage. The sequence begins with the first ONE of 9 consecutive ONES; i.e. the shift register is initialized with nine ones. Number of shift register stages: 9
Length of pseudo-random sequence: $2^9 - 1 = 511$ bits
Longest sequence of zeros: 8 (non-inverted signal)

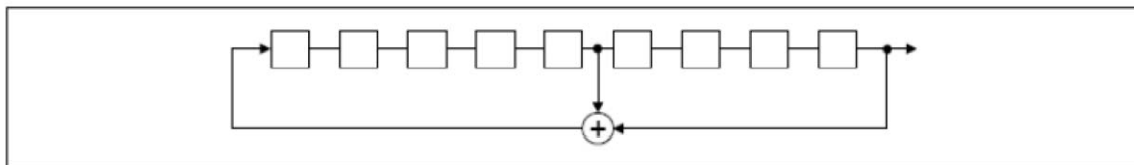

Linear Feedback Shift Register for Generation of the PRBS sequence

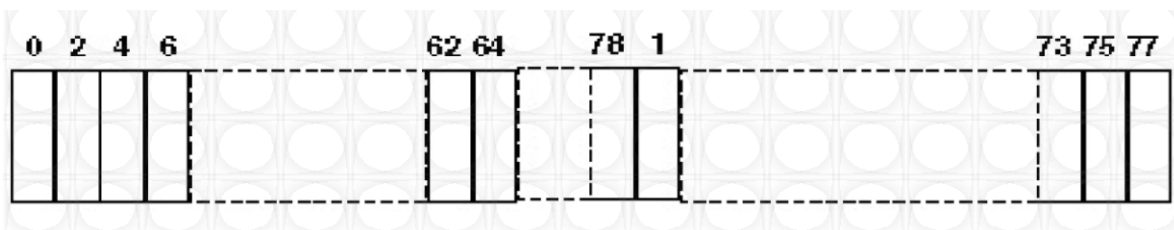

Each frequency used equally on the average by each transmitter. The system receiver have input bandwidths that match the hopping channel bandwidths of their corresponding transmitters and shift frequencies in synchronization with the transmitted signals.

8.3 Equal Hopping Frequency Use

All Bluetooth units participating in the piconet are time and hop-synchronized to the channel.

Example of a 79 hopping sequence in data mode:

40, 14, 44, 8, 27, 53, 46, 55, 48, 33, 63, 35, 50, 65, 54, 67, 56, 37, 60, 39, 58, 69, 62, 71, 64, 25, 68, 26, 66, 57, 70, 59, 72, 29, 76, 31, 74, 61, 78, 3, 1, 41, 5, 43, 2, 73, 7, 75, 09, 45, 13, 47, 11, 77, 15, 00, 4, 49, 56, 23, 18, 02, 7, 6, 10, 21, 32, 5, 12, 48, 34, 20, 28, 52, 38, 17, 22, 30, 42, 16, 51, 36, 21, 19, 24

Each Frequency used equally on the average by each transmitter

8.4 Frequency Hopping System

This transmitter device is frequency hopping device, and complies with FCC part 15.247 rule.

This device uses Bluetooth radio which operates in 2400-2483.5 MHz band. Bluetooth uses a radio technology called frequency-hopping spread spectrum, which chops up the data being sent and transmits chunks of it on up to 79 bands (1 MHz each; centred from 2402 to 2480 MHz) in the range 2,400-2,483.5 MHz. The transmitter switches hop frequencies 1,600 times per second to assure a high degree of data security. All Bluetooth devices participating in a given piconet are synchronized to the frequency-hopping channel for the piconet. The frequency hopping sequence is determined by the master's device address and the phase of the hopping sequence (the frequency to hop at a specific time) is determined by the master's internal clock. Therefore, all slaves in a piconet must know the master's device address and must synchronize their clocks with the master's clock.

Adaptive Frequency Hopping (AFH) was introduced in the Bluetooth specification to provide an effective way for a Bluetooth radio to counteract normal interference. AFH identifies "bad" channels, where either other wireless devices are interfering with the Bluetooth signal or the Bluetooth signal is interfering with another device. The AFH-enabled Bluetooth device will then communicate with other devices within its piconet to share details of any identified bad channels. The devices will then switch to alternative available "good" channels, away from the areas of interference, thus having no impact on the bandwidth used.

9 TEST REQUIREMENTS

9.1 20DB BANDWIDTH

9.1.1 Applicable Standard

According to FCC Part 15.247(a)(1) and DA 00-705

9.1.2 Conformance Limit

No limit requirement.

9.1.3 Test Configuration

Test according to clause 7.1 radio frequency test setup 1

9.1.4 Test Procedure

The EUT was operating in Bluetooth v2.0 /v2.1/v3.0 mode and controlled its channel. Printed out the test result from the spectrum by hard copy function.

The RF output of EUT was connected to the spectrum analyzer by RF cable and attenuator. The path loss was compensated to the results for each measurement.

Set to the maximum power setting and enable the EUT transmit continuously

Set RBW = 30 kHz.

Set the video bandwidth (VBW) =100 kHz.

Set Span= approximately 2 to 3 times the 20 dB bandwidth

Set Detector = Peak.

Set Trace mode = max hold.

Set Sweep = auto couple.

The EUT should be transmitting at its maximum data rate. Allow the trace to stabilize. Use the marker-to-peak function to set the marker to the peak of the emission. Use the marker-delta function to measure 20 dB down one side of the emission. Reset the markerdelta function, and move the marker to the other side of the emission, until it is (as close as possible to) even with the reference marker level. The marker-delta reading at this point is the 20 dB bandwidth of the emission.

If this value varies with different modes of operation (e.g., data rate, modulation format, etc.), repeat this test for each variation.

Measure and record the results in the test report.

Test Results

Temperature: 24°C
Humidity: 53 %

Test Date: May 17, 2015
Test By: KING KONG

| Modulation Mode | Channel Number | Channel Frequency (MHz) | Measurement Bandwidth (kHz) | Limit (kHz) | Verdict |
|-----------------|----------------|-------------------------|-----------------------------|-------------|---------|
| GFSK | 00 | 2402 | 1043.00 | N/A | PASS |
| | 39 | 2441 | 1042.00 | N/A | PASS |
| | 78 | 2480 | 1043.00 | N/A | PASS |
| pi/4-DQPSK | 00 | 2402 | 1292.00 | N/A | PASS |
| | 39 | 2441 | 1294.00 | N/A | PASS |
| | 78 | 2480 | 1299.00 | N/A | PASS |
| 8DPSK | 00 | 2402 | 1306.00 | N/A | PASS |
| | 39 | 2441 | 1316.00 | N/A | PASS |
| | 78 | 2480 | 1307.00 | N/A | PASS |

Note: N/A (Not Applicable)

| | | |
|------------|---------------------------|-----------------|
| Test Model | 20dB Bandwidth | |
| | Bluetooth v2.0 /v2.1/v3.0 | |
| | Channel 0: 2402MHz | GFSK Modulation |

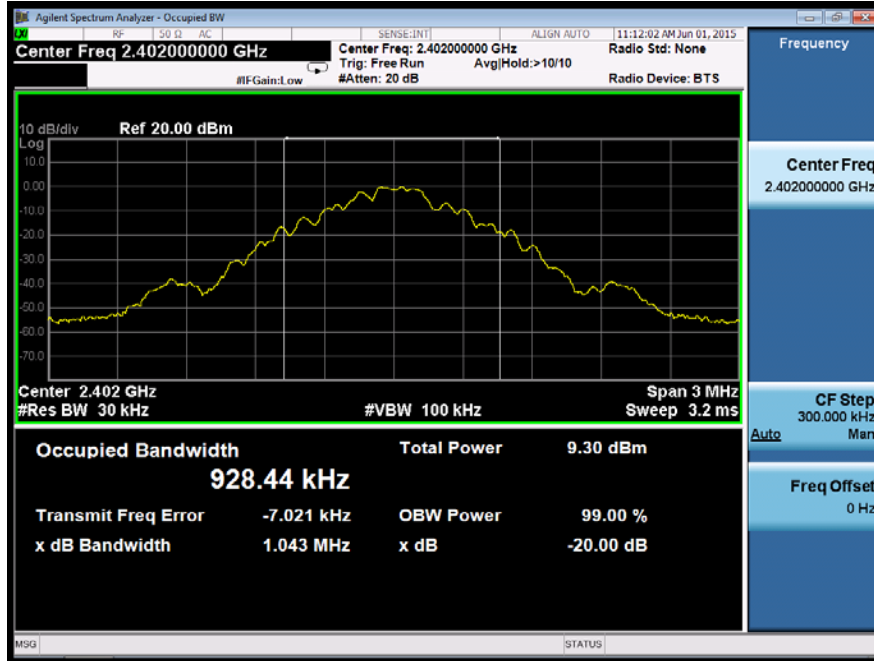

| | | |
|------------|---------------------------|-----------------|
| Test Model | 20dB Bandwidth | |
| | Bluetooth v2.0 /v2.1/v3.0 | |
| | Channel 39: 2441MHz | GFSK Modulation |



| | | |
|------------|---------------------------|-----------------|
| Test Model | 20dB Bandwidth | |
| | Bluetooth v2.0 /v2.1/v3.0 | |
| | Channel 78: 2480MHz | GFSK Modulation |



| | | |
|------------|---------------------------|-----------------------|
| Test Model | 20dB Bandwidth | |
| | Bluetooth v2.0 /v2.1/v3.0 | |
| | Channel 0: 2402MHz | pi/4-DQPSK Modulation |

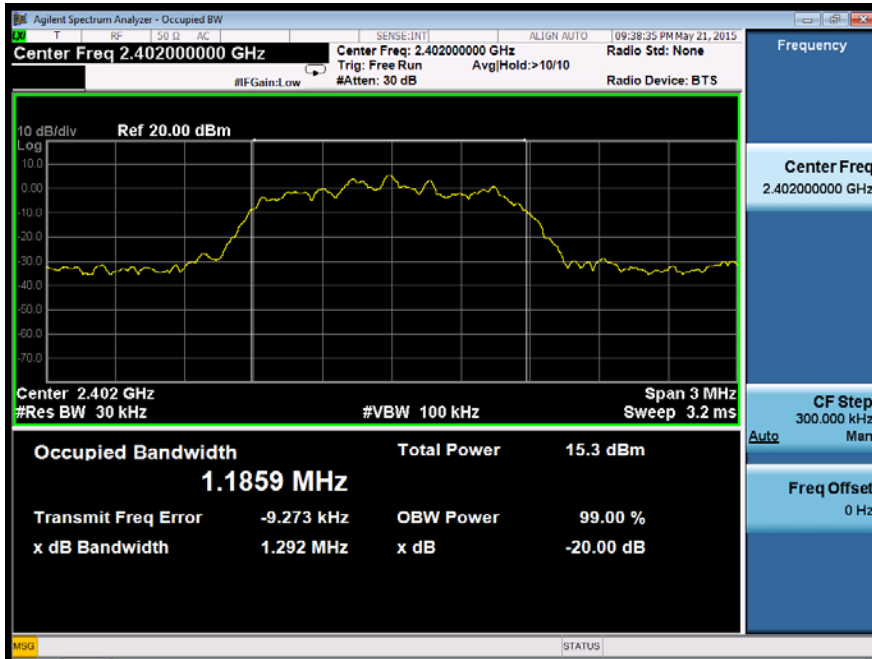

| | | |
|------------|---------------------------|-----------------------|
| Test Model | 20dB Bandwidth | |
| | Bluetooth v2.0 /v2.1/v3.0 | |
| | Channel 39: 2441MHz | pi/4-DQPSK Modulation |

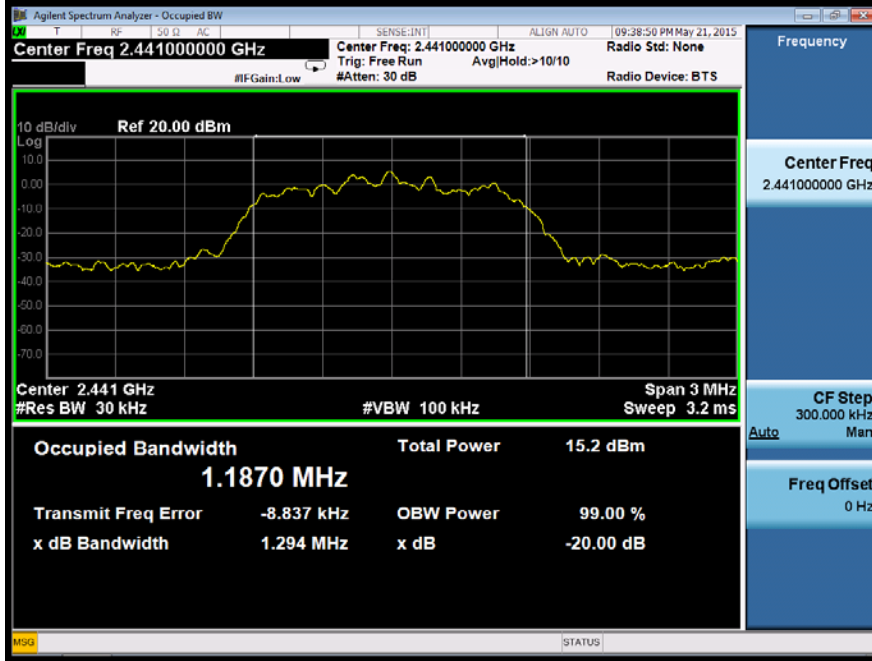

| | | |
|------------|---------------------------|-----------------------|
| Test Model | 20dB Bandwidth | |
| | Bluetooth v2.0 /v2.1/v3.0 | |
| | Channel 78: 2480MHz | pi/4-DQPSK Modulation |

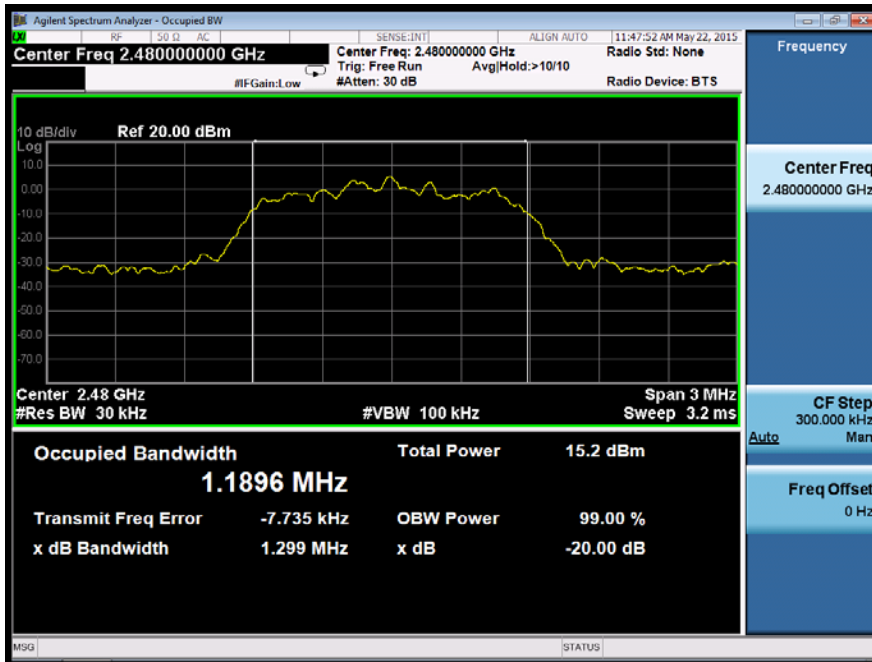

| | | |
|------------|---------------------------|------------------|
| Test Model | 20dB Bandwidth | |
| | Bluetooth v2.0 /v2.1/v3.0 | |
| | Channel 0: 2402MHz | 8DPSK Modulation |

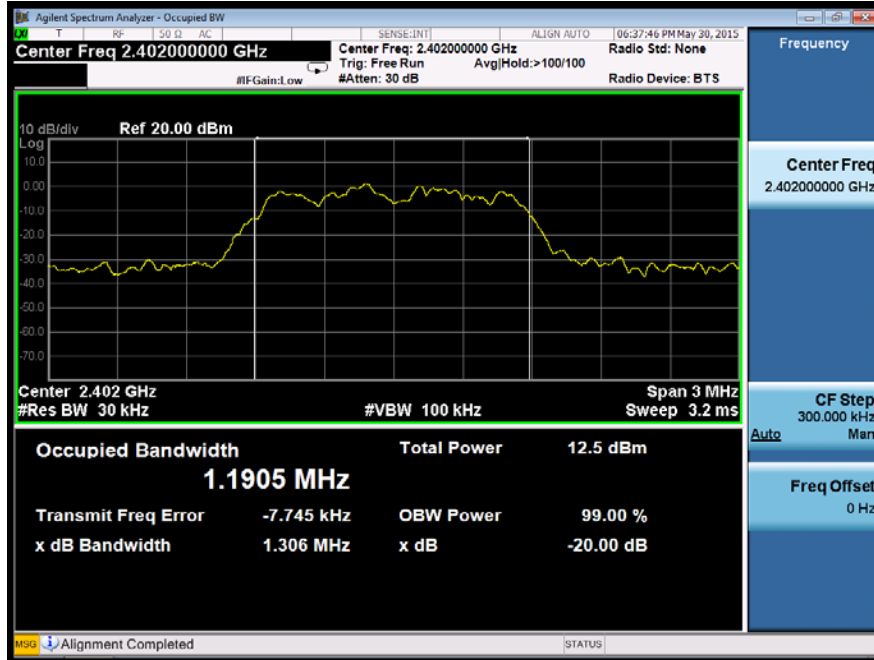

| | | |
|------------|---------------------------|------------------|
| Test Model | 20dB Bandwidth | |
| | Bluetooth v2.0 /v2.1/v3.0 | |
| | Channel 39: 2441MHz | 8DPSK Modulation |

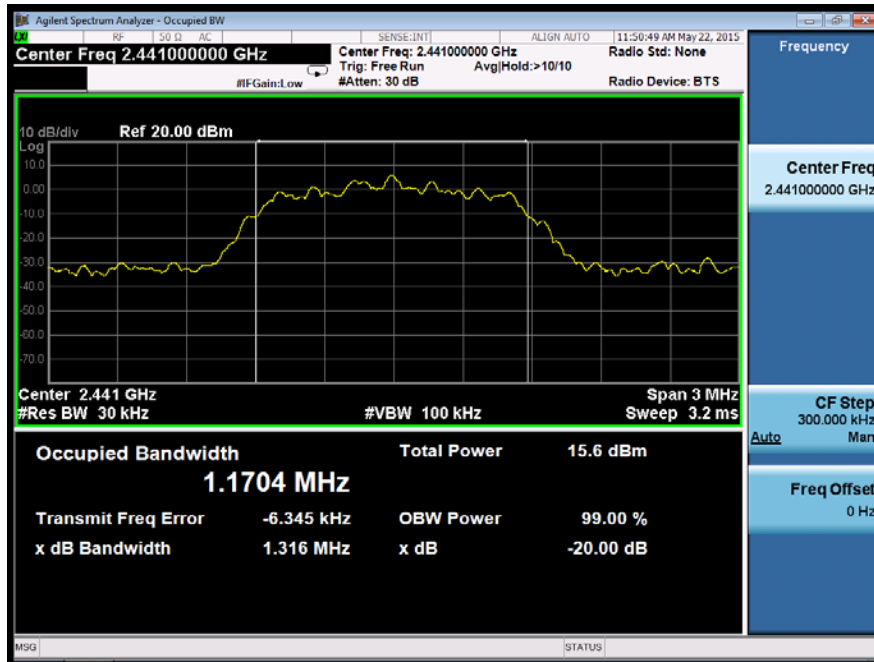

| | | |
|------------|---------------------------|------------------|
| Test Model | 20dB Bandwidth | |
| | Bluetooth v2.0 /v2.1/v3.0 | |
| | Channel 78: 2480MHz | 8DPSK Modulation |

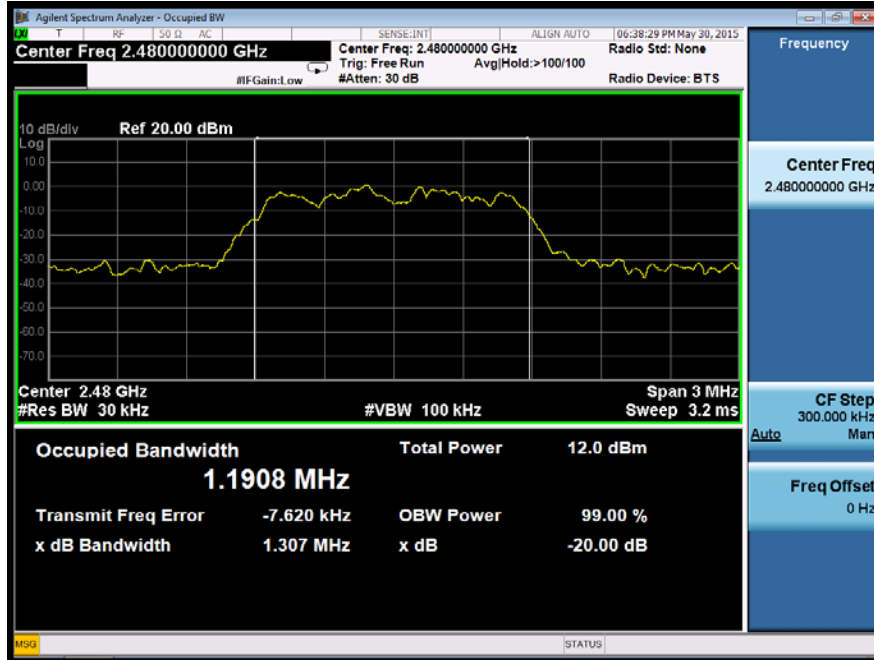

9.2 CARRIER FREQUENCY SEPARATION

9.2.1 Applicable Standard

According to FCC Part 15.247(a)(1) and DA 00-705

9.2.2 Conformance Limit

Frequency hopping systems operating in the 2400-2483.5MHz band shall have hopping channel carrier frequencies separated by a minimum of 25kHz or the 20dB bandwidth of the hopping channel, whichever is greater.

In case of an output power less than 125mW, the frequency hopping system may have channels separated by a minimum of 25kHz or two-thirds of the 20dB bandwidth of the hopping channel, whichever is greater.

9.2.3 Test Configuration

Test according to clause 7.1 radio frequency test setup 1

9.2.4 Test Procedure

■ According to FCC Part 15.247(a)(1)

The EUT must have its hopping function enabled. Use the following spectrum analyzer settings:

Set the RBW = 100kHz.

Set VBW = 300kHz.

Set the span = wide enough to capture the peaks of two adjacent channels

Set Sweep time = auto couple.

Set Detector = peak.

Set Trace mode = max hold.

Allow the trace to stabilize. Use the marker-delta function to determine the separation between the peaks of the adjacent channels. The limit is specified in one of the subparagraphs of this Section. Submit this plot.

Test Results

Temperature: 24 °C
Humidity: 53 %

Test Date: May 17, 2015
Test By: KING KONG

| Modulation Mode | Channel Number | Channel Frequency (MHz) | Measurement Bandwidth (kHz) | Limit (kHz) | Verdict |
|-----------------|----------------|-------------------------|-----------------------------|-------------|---------|
| GFSK | 0 | 2402 | 1000.00 | >695.333 | PASS |
| | 39 | 2441 | 1000.00 | >694.667 | PASS |
| | 78 | 2480 | 1000.00 | >695.333 | PASS |
| pi/4-DQPSK | 0 | 2402 | 1000.00 | >861.333 | PASS |
| | 39 | 2441 | 1000.00 | >862.667 | PASS |
| | 78 | 2480 | 1000.00 | >866.000 | PASS |
| 8DPSK | 0 | 2402 | 1000.00 | >870.667 | PASS |
| | 39 | 2441 | 1000.00 | >877.333 | PASS |
| | 78 | 2480 | 1000.00 | >871.333 | PASS |

Note: Limit = 20dB bandwidth*2/3 for GFSK, pi/4-DQPSK & 8DPSK Modulation, if it is greater than 25kHz and the output power is less than 125mW (21dBm).

| | | |
|------------|------------------------------|-----------------|
| Test Model | Carrier Frequency Separation | |
| | Bluetooth v2.0 /v2.1/v3.0 | |
| | Channel 0: 2402MHz | GFSK Modulation |

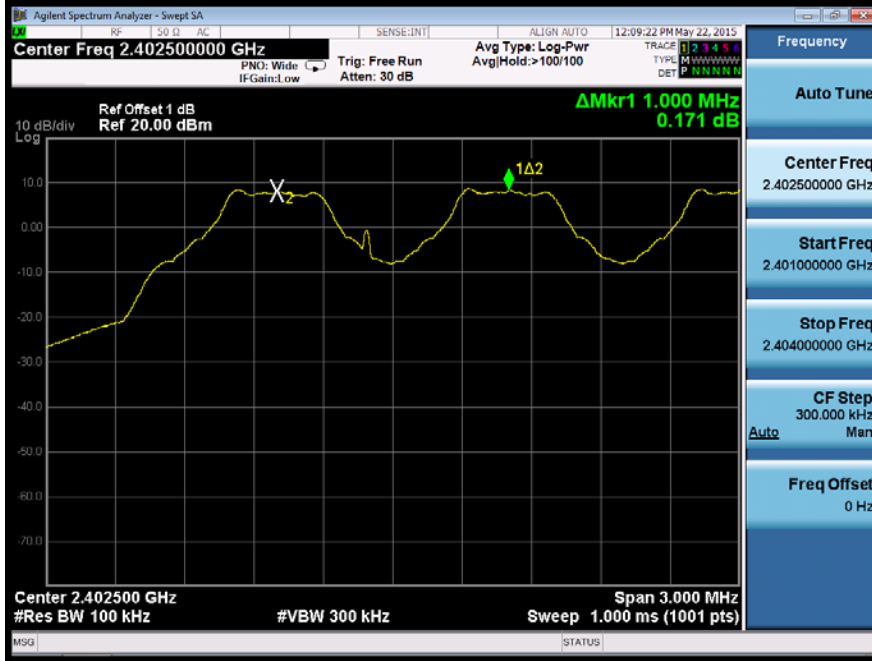

| | | |
|------------|------------------------------|-----------------|
| Test Model | Carrier Frequency Separation | |
| | Bluetooth v2.0 /v2.1/v3.0 | |
| | Channel 39: 2441MHz | GFSK Modulation |

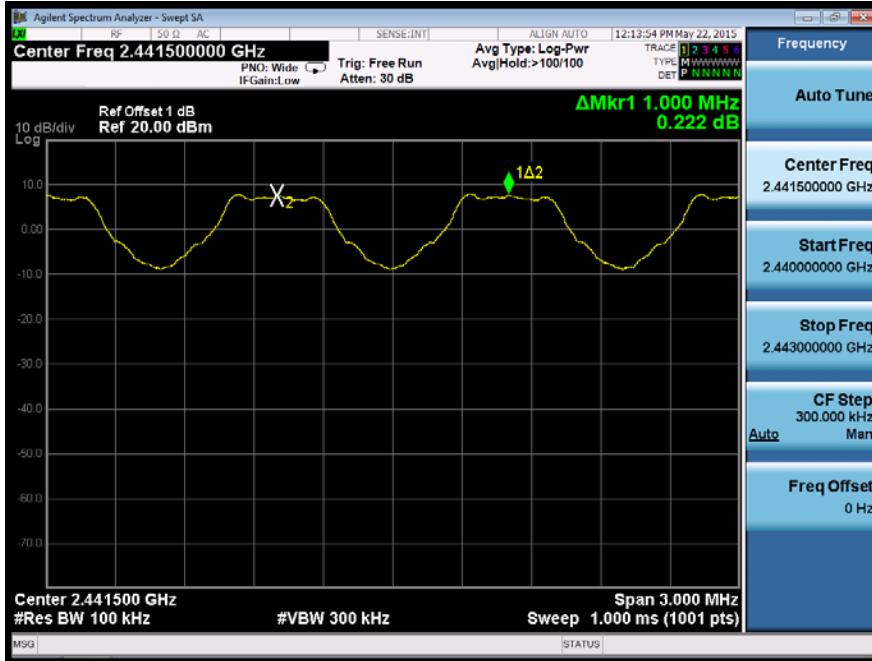

| | | |
|------------|------------------------------|-----------------|
| Test Model | Carrier Frequency Separation | |
| | Bluetooth v2.0 /v2.1/v3.0 | |
| | Channel 78: 2480MHz | GFSK Modulation |

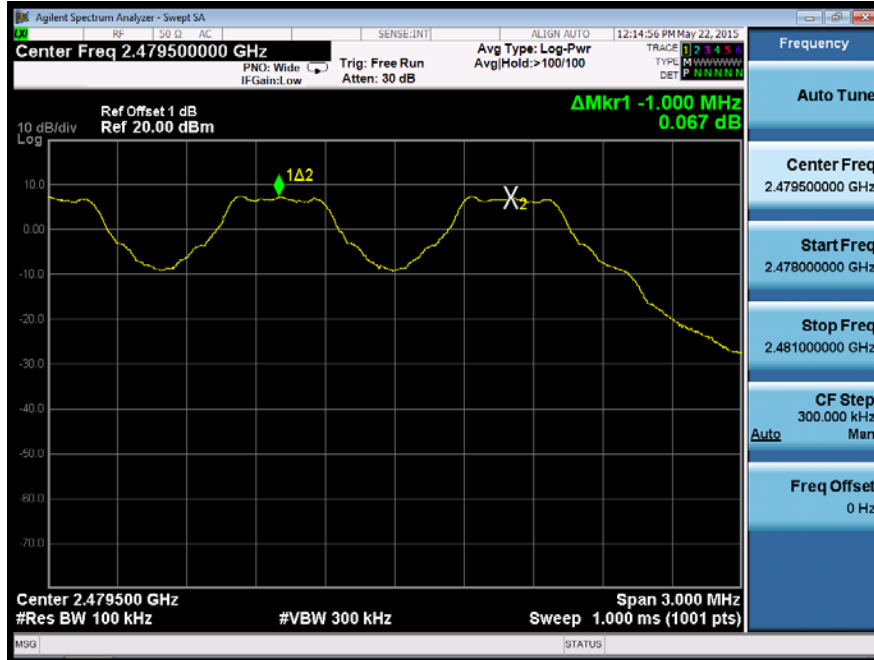

| | | |
|------------|------------------------------|-----------------------|
| Test Model | Carrier Frequency Separation | |
| | Bluetooth v2.0 /v2.1/v3.0 | |
| | Channel 0: 2402MHz | pi/4-DQPSK Modulation |

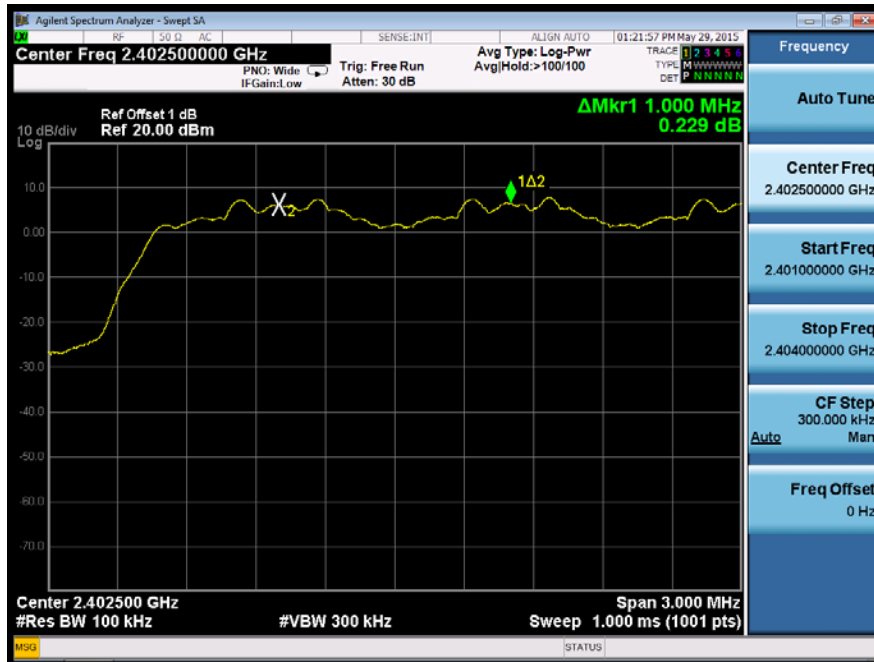

| | | |
|------------|------------------------------|-----------------------|
| Test Model | Carrier Frequency Separation | |
| | Bluetooth v2.0 /v2.1/v3.0 | |
| | Channel 39: 2441MHz | pi/4-DQPSK Modulation |

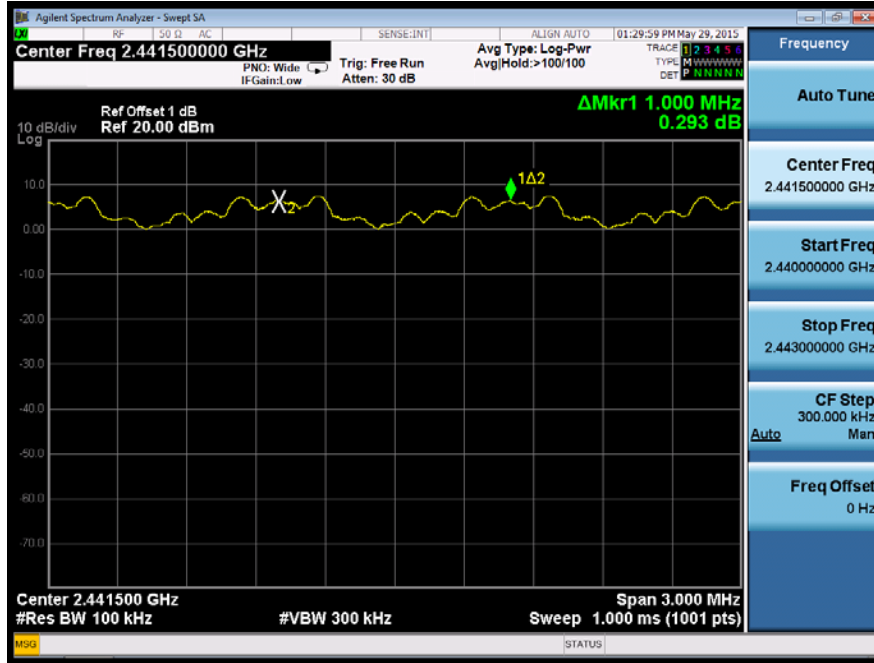

| | | |
|------------|------------------------------|-----------------------|
| Test Model | Carrier Frequency Separation | |
| | Bluetooth v2.0 /v2.1/v3.0 | |
| | Channel 78: 2480MHz | pi/4-DQPSK Modulation |



| | | |
|------------|------------------------------|------------------|
| Test Model | Carrier Frequency Separation | |
| | Bluetooth v2.0 /v2.1/v3.0 | |
| | Channel 0: 2402MHz | 8DPSK Modulation |

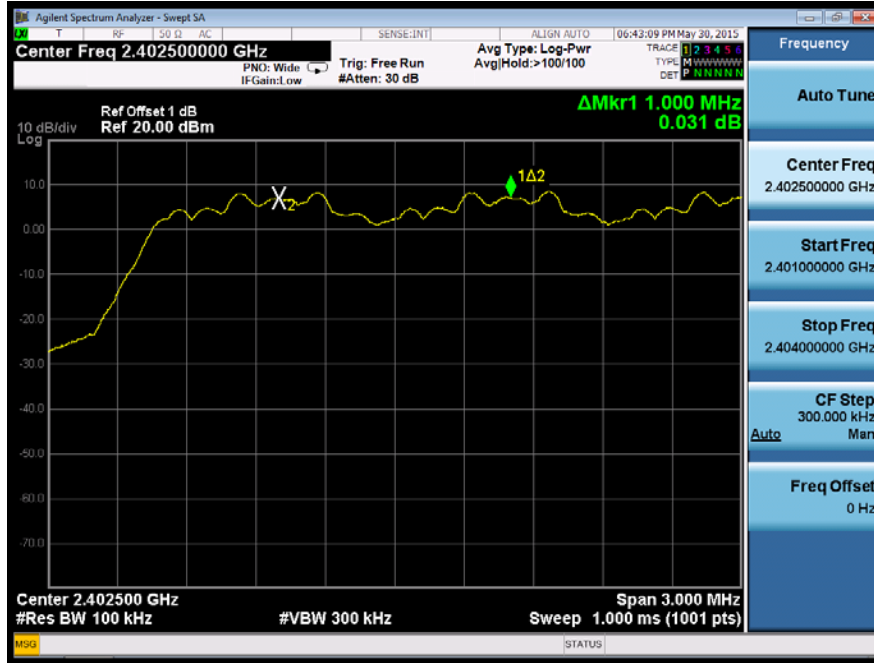

| | | |
|------------|------------------------------|------------------|
| Test Model | Carrier Frequency Separation | |
| | Bluetooth v2.0 /v2.1/v3.0 | |
| | Channel 39: 2441MHz | 8DPSK Modulation |

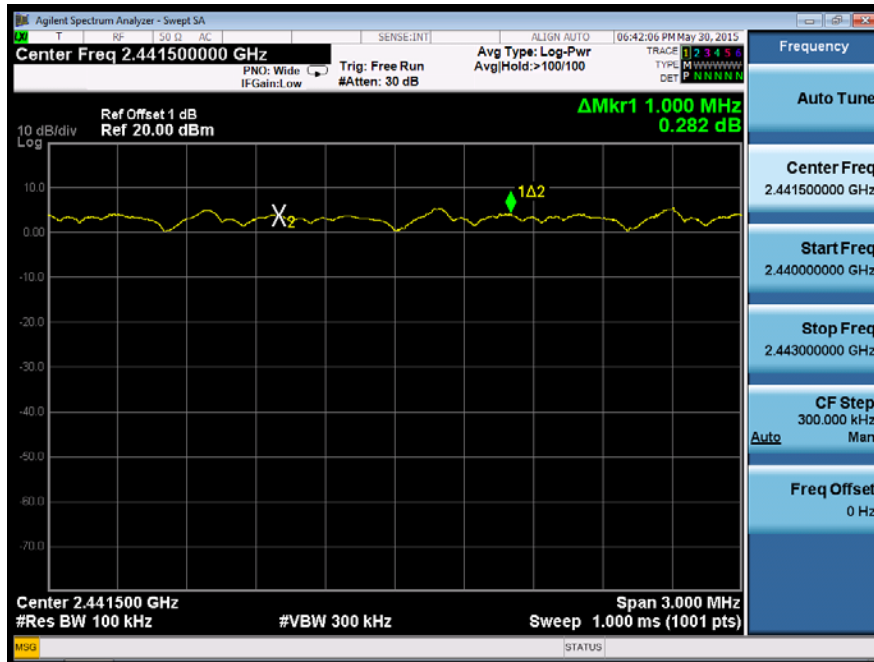

| | | |
|------------|------------------------------|------------------|
| Test Model | Carrier Frequency Separation | |
| | Bluetooth v2.0 /v2.1/v3.0 | |
| | Channel 78: 2480MHz | 8DPSK Modulation |



9.3 NUMBER OF HOPPING FREQUENCIES

9.3.1 Applicable Standard

According to FCC Part 15.247(a)(1) (iii) and DA 00-705

9.3.2 Conformance Limit

Frequency hopping systems operating in the 2400-2483.5MHz band shall use at least 15 channels.

9.3.3 Test Configuration

Test according to clause 7.1 radio frequency test setup 1

9.3.4 Test Procedure

- According to FCC Part 15.247(a)(1)(iii)

The EUT must have its hopping function enabled. Use the following spectrum analyzer settings:

Span = the frequency band of operation (2390-2440MHz) and (2440-2490MHz)

RBW \geq 1% of the span

VBW \geq RBW

Sweep = auto

Detector function = peak

Trace = max hold

Allow the trace to stabilize. It may prove necessary to break the span up to sections, in order to clearly show all of the hopping frequencies.

Test Results

| | | | |
|--------------------|-----------|---------------|--------------|
| Spectrum Detector: | PK | Test Date : | May 17, 2015 |
| Test By: | KING KONG | Temperature : | 24°C |
| Test Result: | PASS | Humidity : | 53 % |

| Hopping Channel Frequency Range (MHz) | Quantity of Hopping Channel | Quantity of Hopping Channel limit |
|---------------------------------------|-----------------------------|-----------------------------------|
| 2400-2483.5 | 79 | ≥ 15 |

| | | |
|------------|-------------------------------|--|
| Test Model | Number Of Hopping Frequencies | |
| | Bluetooth v2.0 /v2.1/v3.0 | |
| | Span: 2390-2440MHz | |

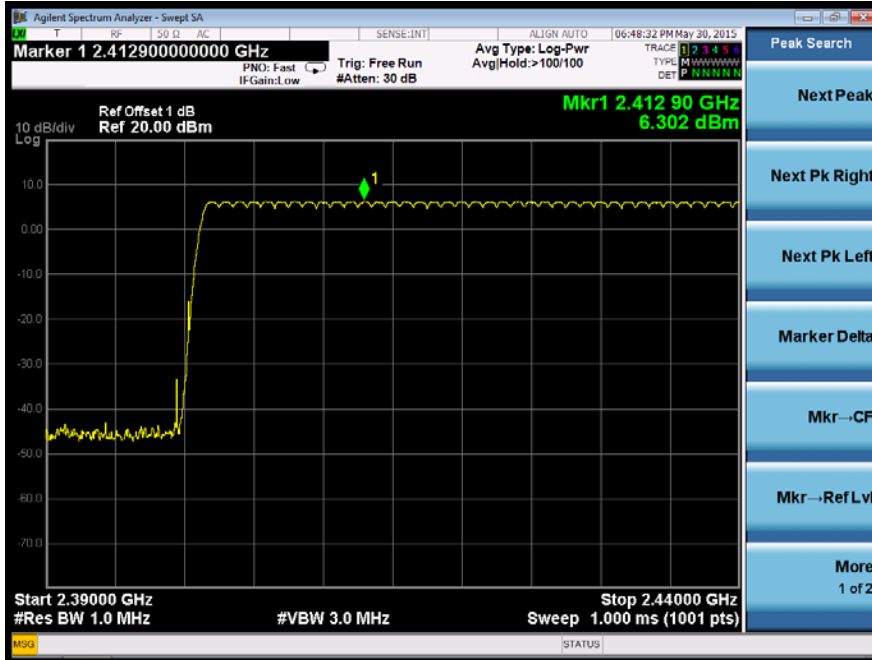

| | | |
|------------|-------------------------------|--|
| Test Model | Number Of Hopping Frequencies | |
| | Bluetooth v2.0 /v2.1/v3.0 | |
| | Span: 2440-2490MHz | |

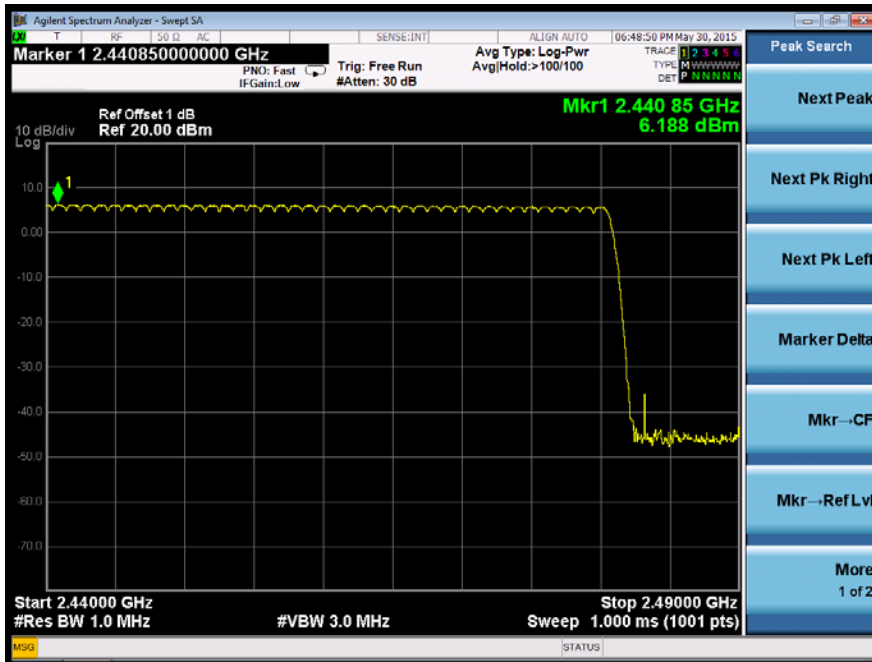

9.4 AVERAGE TIME OF OCCUPANCY (DWELL TIME)

9.4.1 Applicable Standard

According to FCC Part 15.247(a)(1)(iii) and DA 00-705

9.4.2 Conformance Limit

For frequency hopping systems operating in the 2400-2483.5MHz band, the average time of occupancy on any channel shall not be greater than 0.4s within a period of 0.4s multiplied by the number of hopping channels employed.

9.4.3 Test Configuration

Test according to clause 7.1 radio frequency test setup 1

9.4.4 Test Procedure

- According to FCC Part 15.247(a)(1)(iii)
 The EUT must have its hopping function enabled. Use the following spectrum analyzer settings:
 Span = zero span, centered on a hopping channel
 RBW = 1 MHz
 VBW ≥ RBW
 Sweep = as necessary to capture the entire dwell time per hopping channel
 Detector function = peak
 Trace = max hold
 If possible, use the marker-delta function to determine the dwell time. If this value varies with different modes of operation (e.g., data rate, modulation format, etc.), repeat this test for each variation. The limit is specified in one of the subparagraphs of this Section.

9.4.5 Test Results

Temperature: 24°C Test Date: May 17, 2015
 Humidity: 53 % Test By: KING KONG

| Modulation Mode | Channel Number | Packet type | Pulse width (ms) | Number per channel in 31.6s (79 Hopping*0.4) | dwell time (ms) | Limit (ms) | Verdict |
|-----------------|----------------|-------------|------------------|---|-----------------|------------|---------|
| GFSK | 0 | DH1 | 0.366 | $1600/(2*79) \times 31.6 = 320$ | 117.120 | <400 | PASS |
| | 0 | DH3 | 1.624 | $1600/(4*79) \times 31.6 = 160$ | 259.840 | <400 | PASS |
| | 0 | DH5 | 2.880 | $1600/(6*79) \times 31.6 = 106.67$ | 307.210 | <400 | PASS |
| Note: | | | | | | | |

| | | |
|------------|--|----------|
| Test Model | Average Time Of Occupancy (Dwell Time) | |
| | Bluetooth v2.0 /v2.1/v3.0 | |
| | CH 0: 2402MHz | GFSK DH1 |

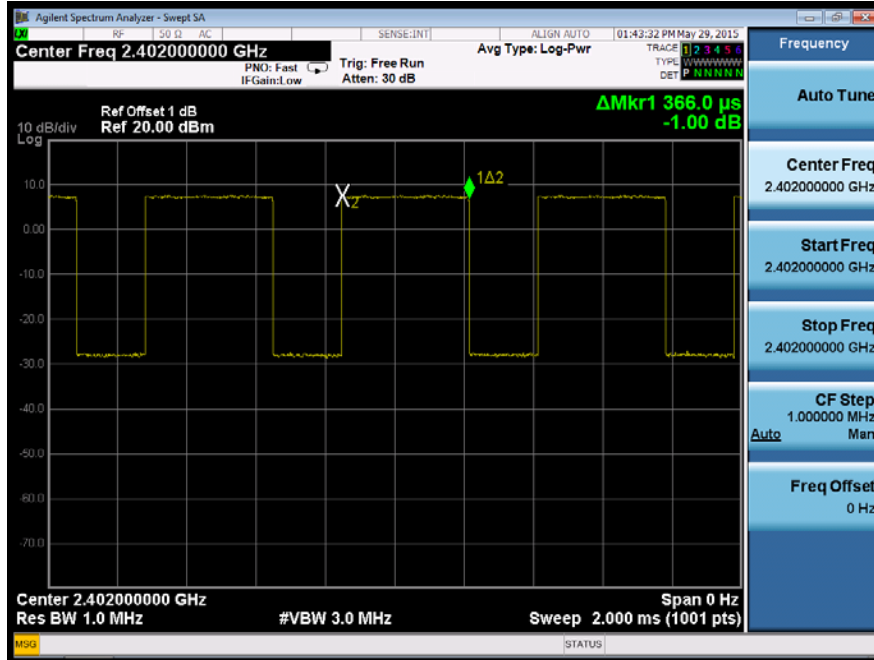

| | | |
|------------|--|----------|
| Test Model | Average Time Of Occupancy (Dwell Time) | |
| | Bluetooth v2.0 /v2.1/v3.0 | |
| | CH 0: 2402MHz | GFSK DH3 |

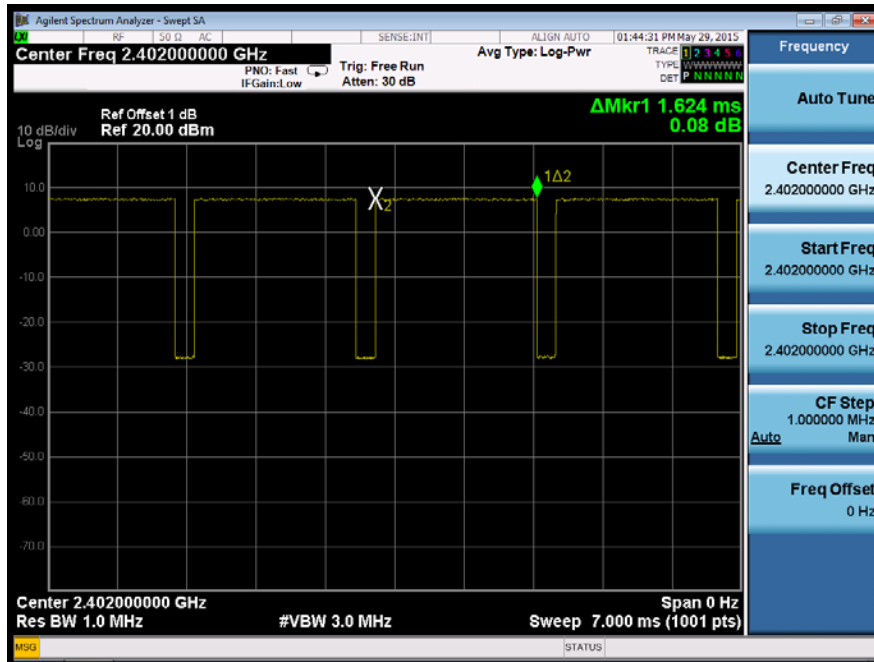

| | | |
|------------|--|----------|
| Test Model | Average Time Of Occupancy (Dwell Time) | |
| | Bluetooth v2.0 /v2.1/v3.0 | |
| | CH 0: 2402MHz | GFSK DH5 |

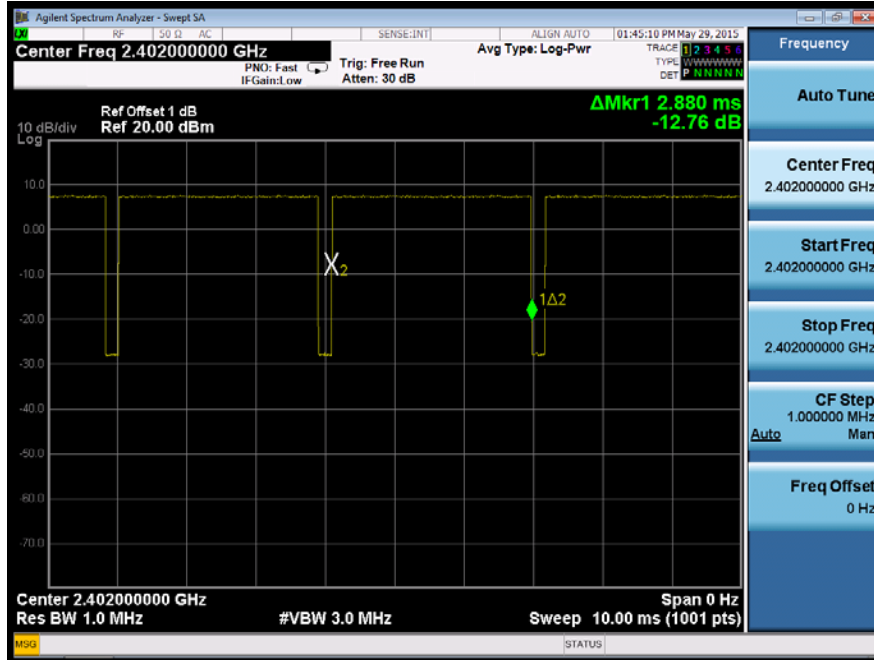

9.5 MAXIMUM PEAK CONDUCTED OUTPUT POWER

9.5.1 Applicable Standard

According to FCC Part 15.247(b)(1) and DA 00-705

9.5.2 Conformance Limit

The max For frequency hopping systems operating in the 2400-2483.5 MHz band employing at least 75 non-overlapping hopping channels: 1 watt. For all other frequency hopping systems in the 2400-2483.5 MHz band: 0.125 watts.

9.5.3 Test Configuration

Test according to clause 7.1 radio frequency test setup 1

9.5.4 Test Procedure

■ According to FCC Part 15.247(b)(1)

As an alternative to a peak power measurement, compliance with the limit can be based on a measurement of the maximum conducted output power.

Use the following spectrum analyzer settings:

Set Span = approximately 5 times the 20 dB bandwidth, centered on a hopping channel (about 10MHz)

Set RBW > the 20 dB bandwidth of the emission being measured (about 3MHz)

Set VBW ≥ RBW

Set Sweep = auto

Set Detector function = peak

Set Trace = max hold

Allow the trace to stabilize. Use the marker-to-peak function to set the marker to the peak of the emission to determine the peak amplitude level.

Test Results

Temperature: 24°C
Humidity: 53 %

Test Date: May 17, 2015
Test By: KING KONG

| Operation Mode | Channel Number | Channel Frequency (MHz) | Measurement Level (dBm) | Limit (dBm) | Verdict |
|----------------|----------------|-------------------------|-------------------------|-------------|---------|
| GFSK | 0 | 2402 | 9.264 | 21 | PASS |
| | 39 | 2441 | 9.170 | 21 | PASS |
| | 78 | 2480 | 8.687 | 21 | PASS |
| pi/4-DQPSK | 0 | 2402 | 10.429 | 21 | PASS |
| | 39 | 2441 | 10.309 | 21 | PASS |
| | 78 | 2480 | 9.733 | 21 | PASS |
| 8DPSK | 0 | 2402 | 10.599 | 21 | PASS |
| | 39 | 2441 | 10.434 | 21 | PASS |
| | 78 | 2480 | 9.909 | 21 | PASS |

Note: N/A

| | | |
|------------|-------------------------------------|------|
| Test Model | Maximum Peak Conducted Output Power | |
| | Bluetooth v2.0 /v2.1/v3.0 | |
| | Channel 0: 2402MHz | GFSK |

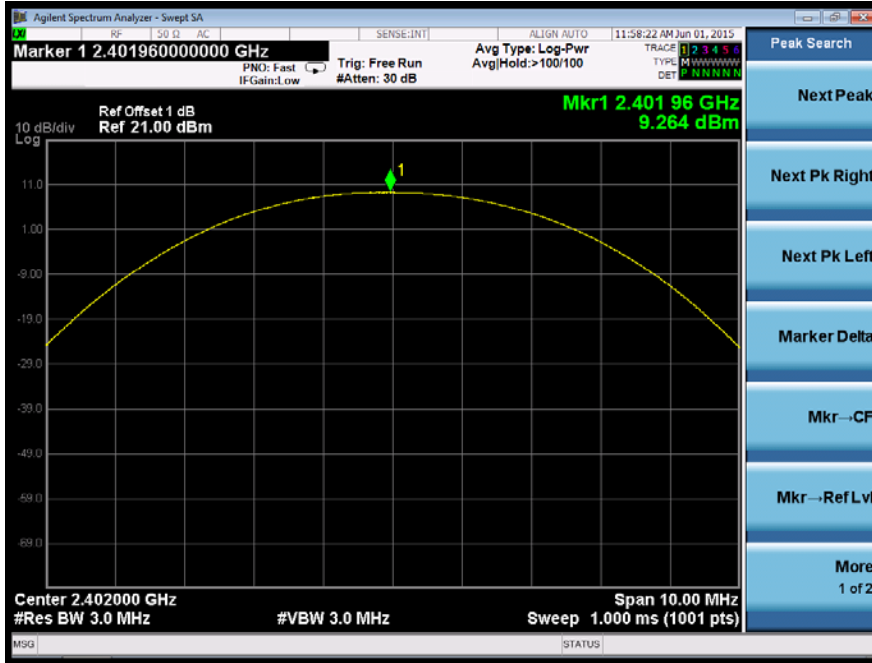

| | | |
|------------|-------------------------------------|------|
| Test Model | Maximum Peak Conducted Output Power | |
| | Bluetooth v2.0 /v2.1/v3.0 | |
| | Channel 39: 2441MHz | GFSK |

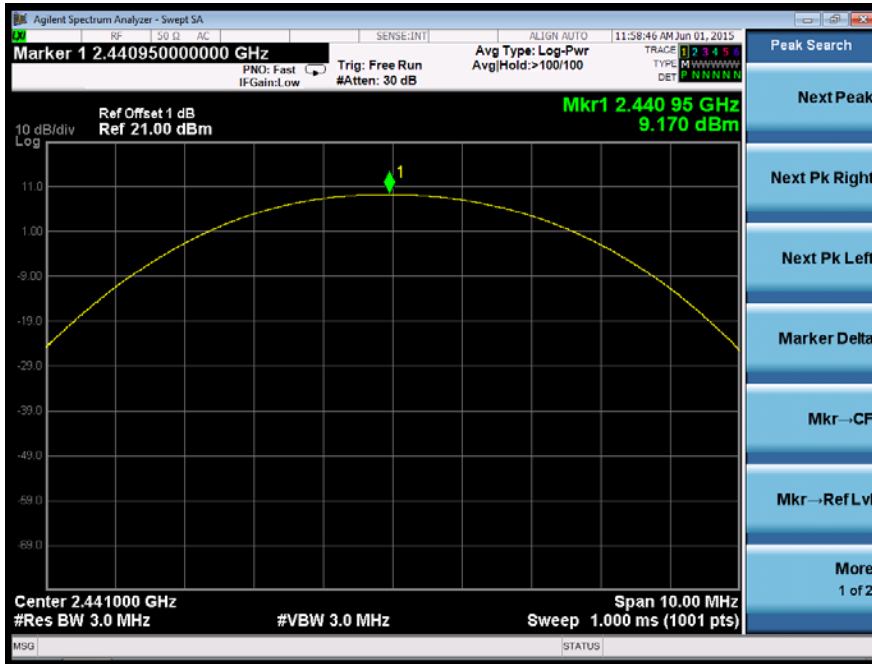

| | | |
|------------|-------------------------------------|------|
| Test Model | Maximum Peak Conducted Output Power | |
| | Bluetooth v2.0 /v2.1/v3.0 | |
| | Channel 78: 2480MHz | GFSK |

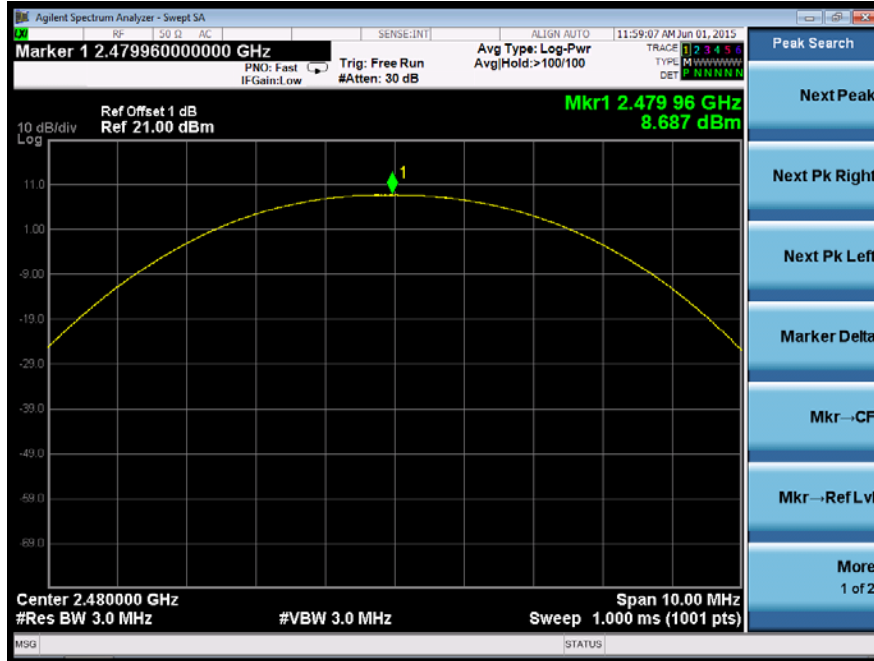

| | | |
|------------|-------------------------------------|------------|
| Test Model | Maximum Peak Conducted Output Power | |
| | Bluetooth v2.0 /v2.1/v3.0 | |
| | Channel 0: 2402MHz | pi/4-DQPSK |

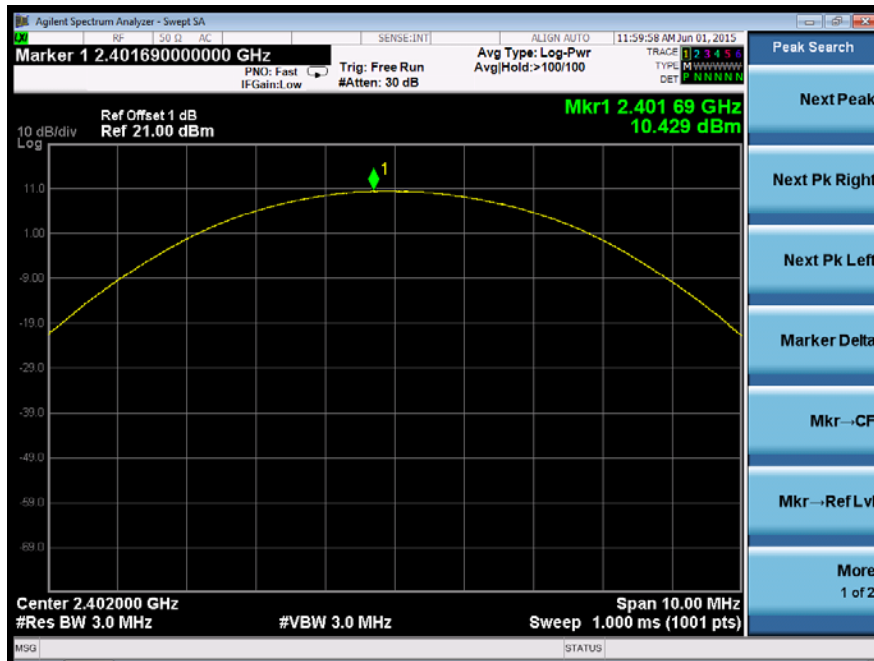

| | | |
|------------|-------------------------------------|------------|
| Test Model | Maximum Peak Conducted Output Power | |
| | Bluetooth v2.0 /v2.1/v3.0 | |
| | Channel 39: 2441MHz | pi/4-DQPSK |

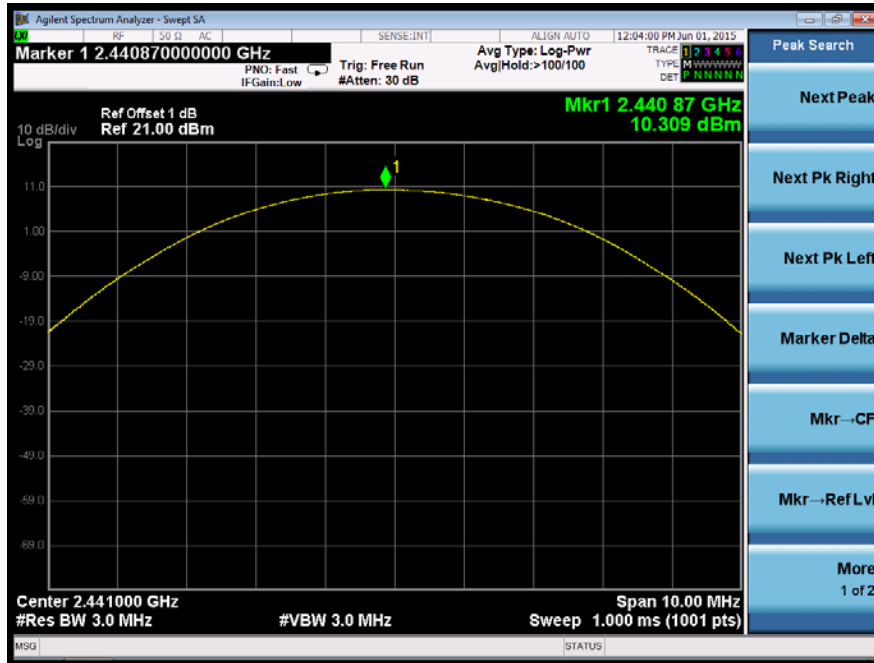

| | | |
|------------|-------------------------------------|------------|
| Test Model | Maximum Peak Conducted Output Power | |
| | Bluetooth v2.0 /v2.1/v3.0 | |
| | Channel 78: 2480MHz | pi/4-DQPSK |

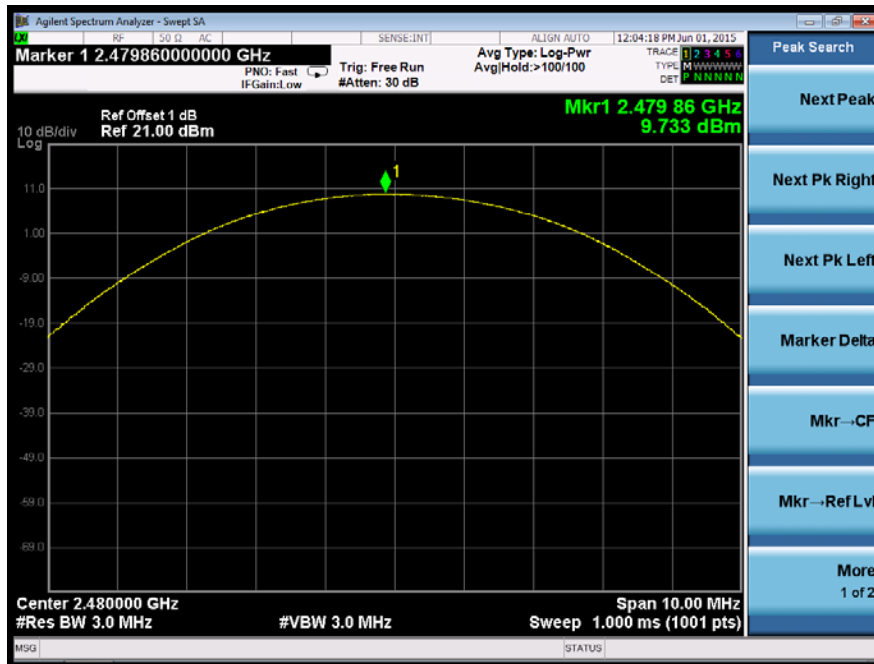

| | | |
|------------|-------------------------------------|-------|
| Test Model | Maximum Peak Conducted Output Power | |
| | Bluetooth v2.0 /v2.1/v3.0 | |
| | Channel 0: 2402MHz | 8DPSK |

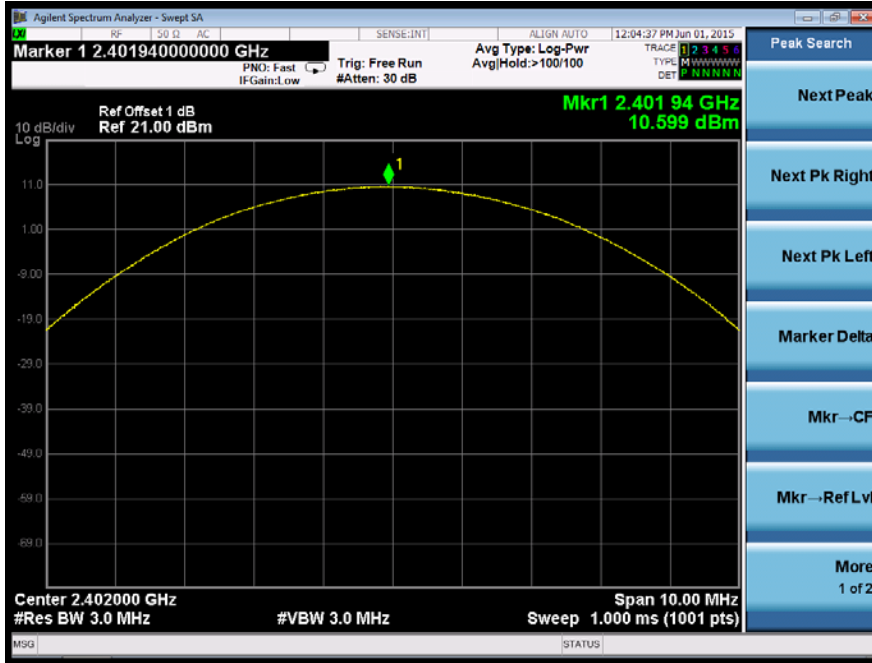

| | | |
|------------|-------------------------------------|-------|
| Test Model | Maximum Peak Conducted Output Power | |
| | Bluetooth v2.0 /v2.1/v3.0 | |
| | Channel 39: 2441MHz | 8DPSK |

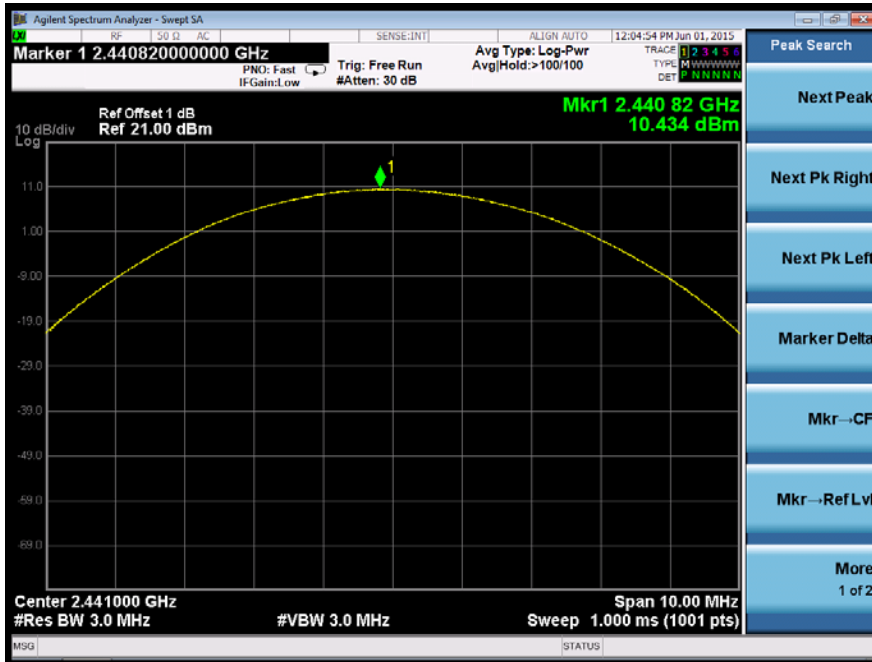

| | | |
|------------|-------------------------------------|-------|
| Test Model | Maximum Peak Conducted Output Power | |
| | Bluetooth v2.0 /v2.1/v3.0 | |
| | Channel 78: 2480MHz | 8DPSK |

