

D

C

B

A

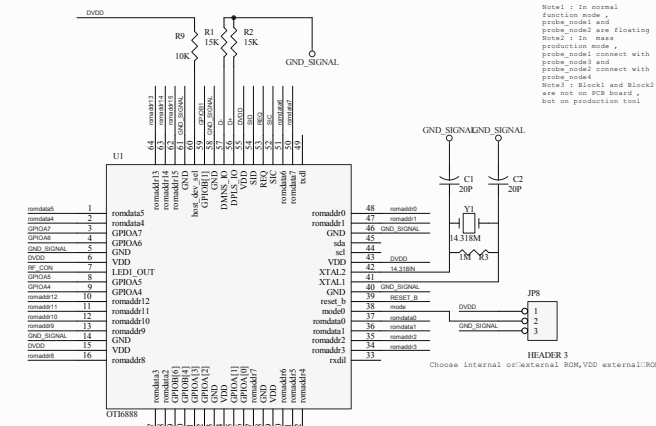

Note1: In normal function mode, probe_model1 and probe_model2 are floating.
 Note2: In mass production mode, probe_model1 connect with probe_model2 and probe_model2 connect with probe_model1.
 Note3: Block1 and Block2 are not on PCB board, but on production tool.

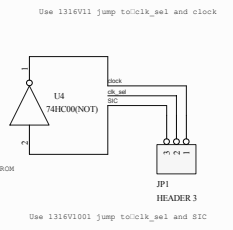
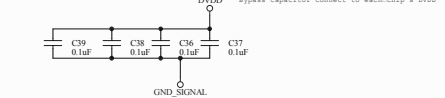
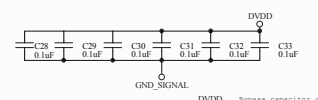

Use 1316V1001 jump to clk_sel and STC

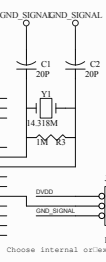

Choose internal or external ROM_VDD external:ROM,GND_SIGNAL internal:ROM

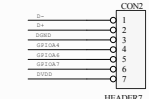
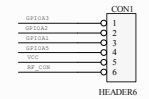
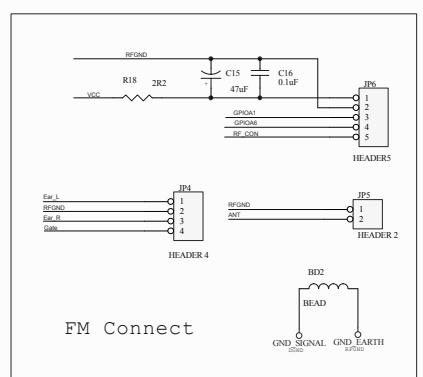
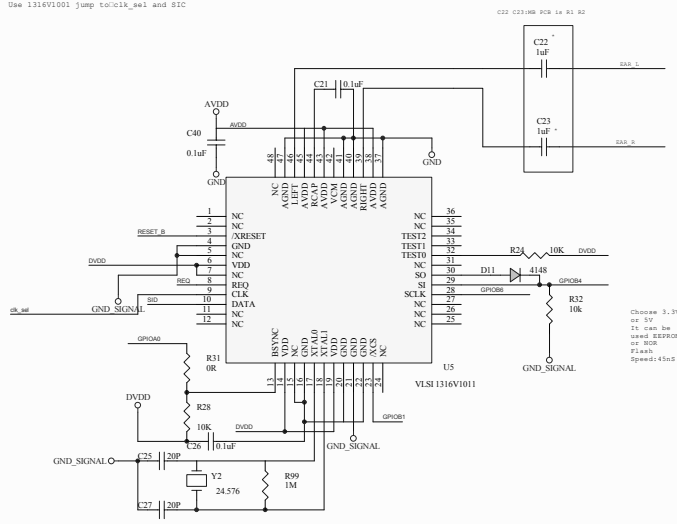
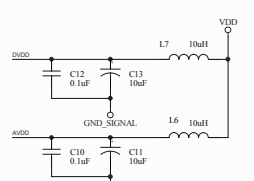
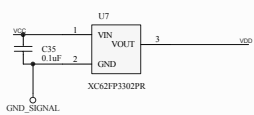
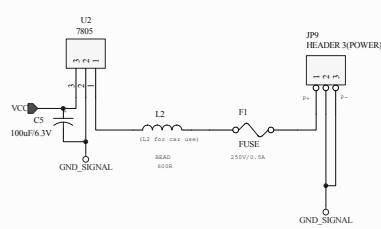

OT16888VLSI1316
 EM190F CAR MP3

Title		
Size	Number	Revision
Over C		
Date:	28-Mar-2005	Sheet of
File:	E:\EM190 FM\pcb file\McDesign.dbs	Drawn By: