

Sensor

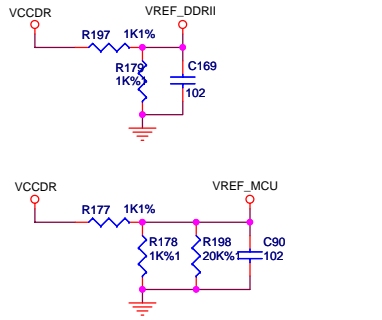

Ver1.1: 增加VLGA封装

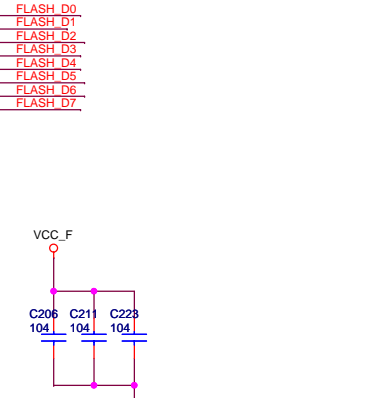
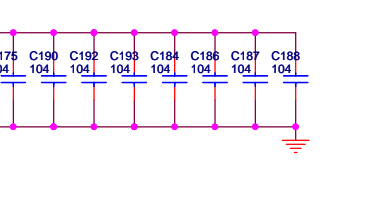
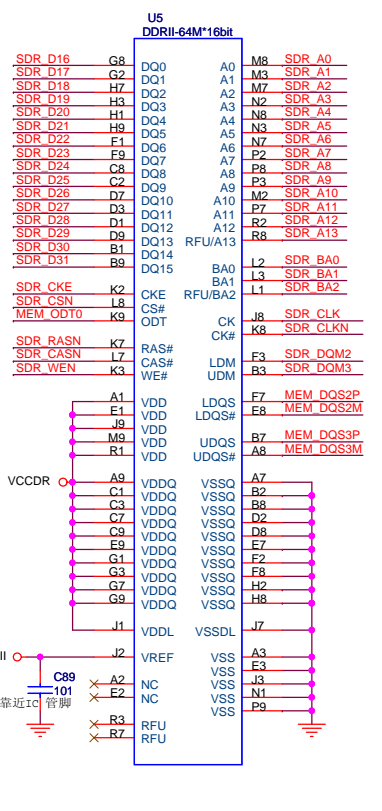
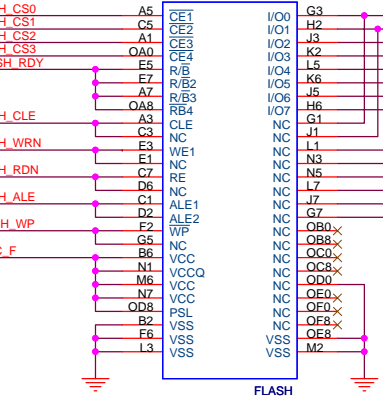
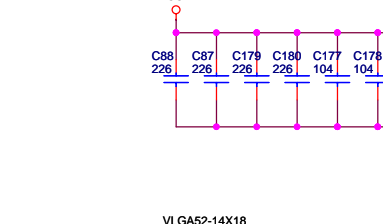
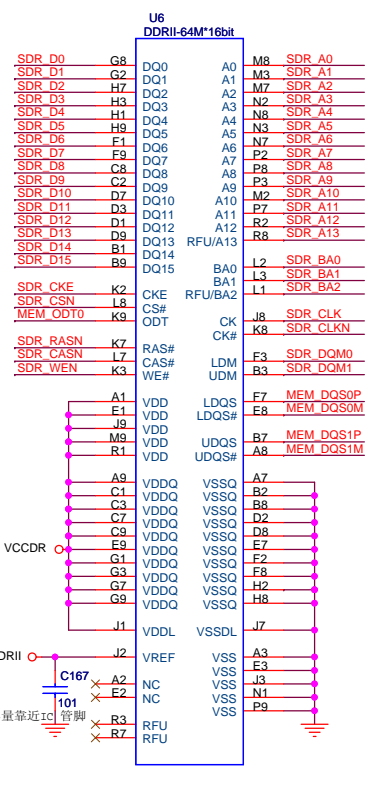
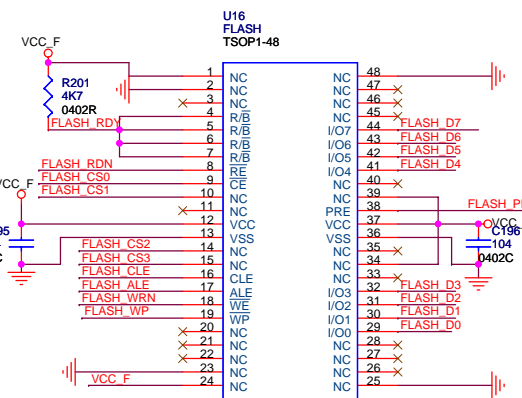
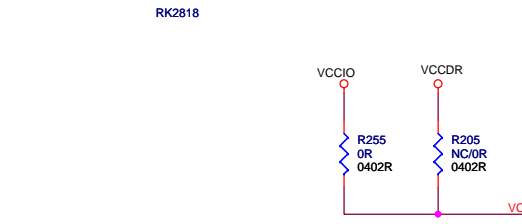
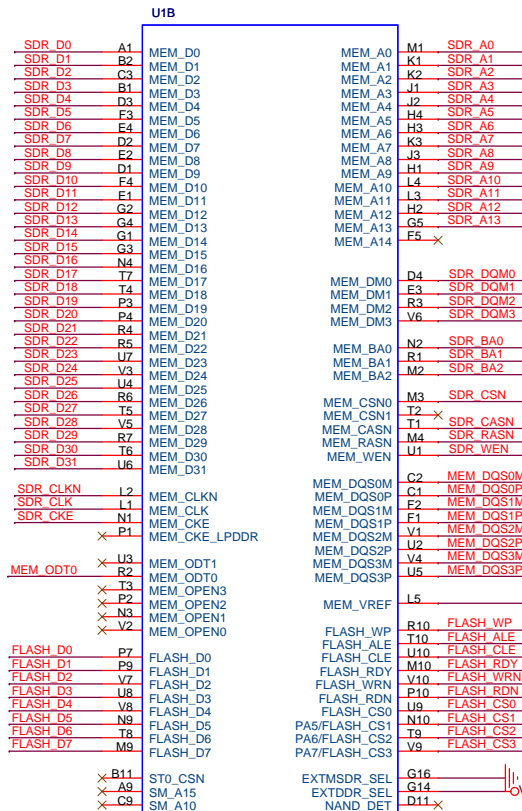
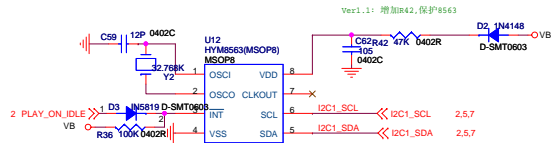
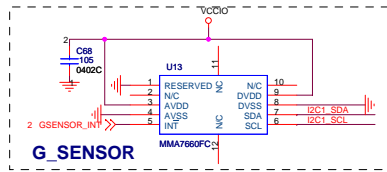

RTC

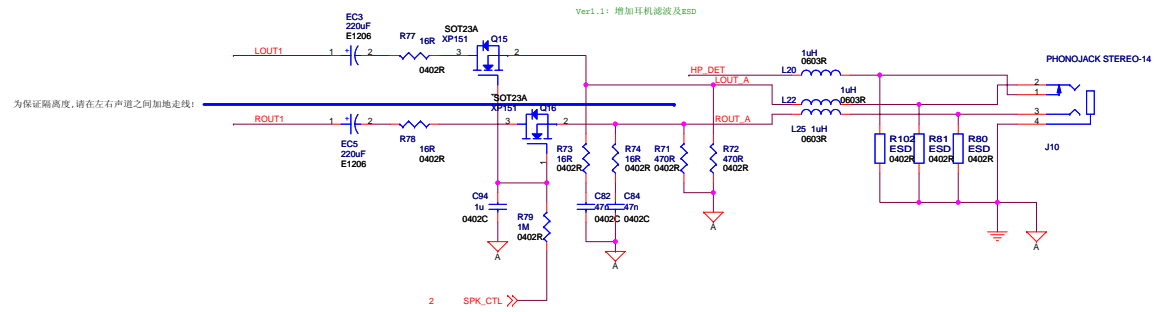
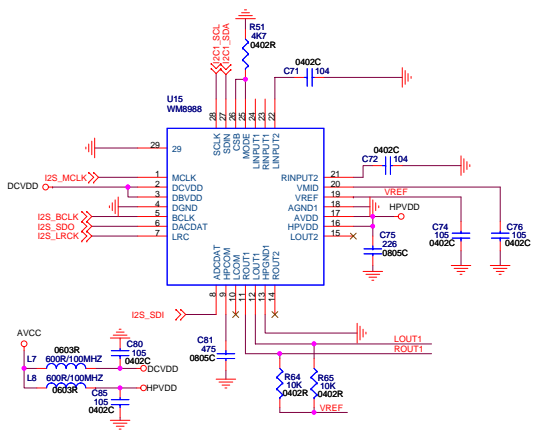
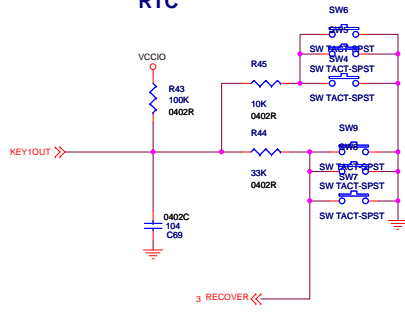

为保证隔离度,请在左右声道之间加地走线:

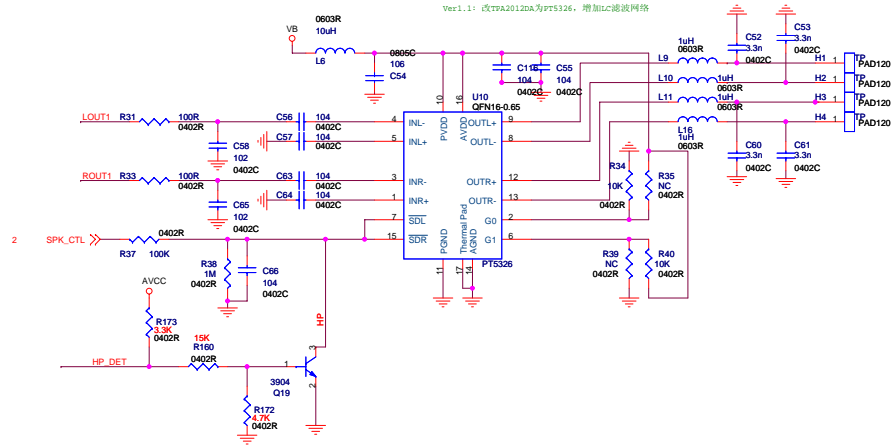

SHENZHEN YIFANG DIGITAL TECHNOLOGY CO.,LTD.			
File	M730U		
Size	Document Number	AUDIO	Rev V1.0
Date:	Thursday, September 09, 2010	Sheet	4 of 7

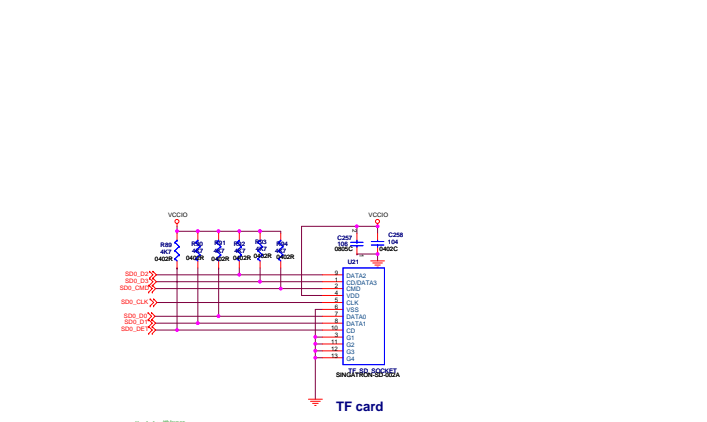
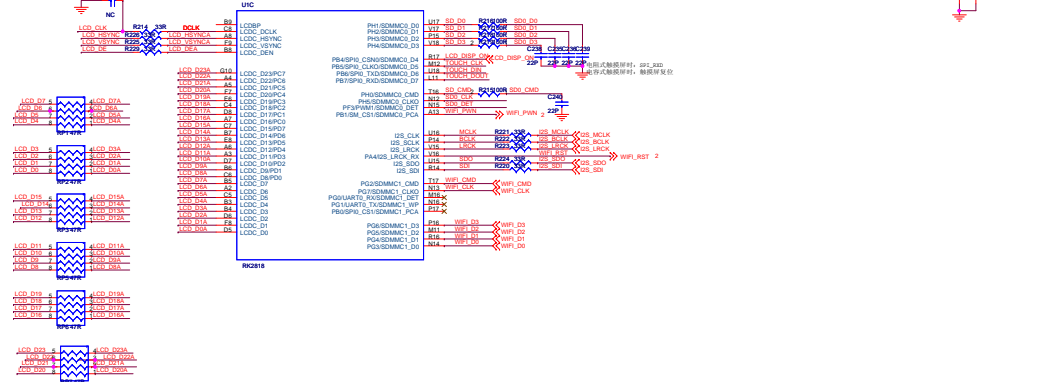
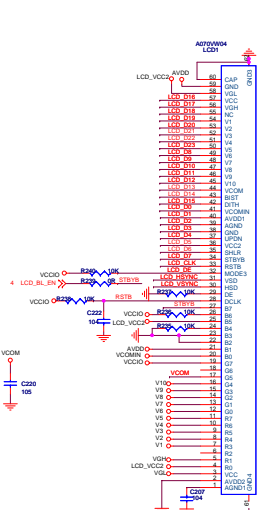
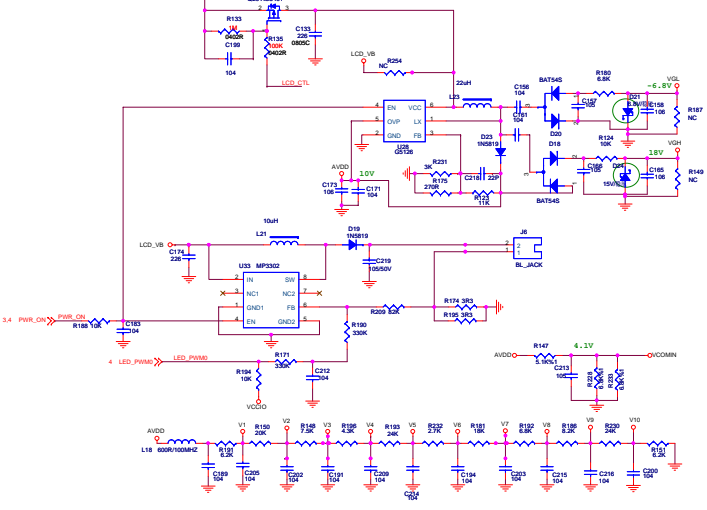
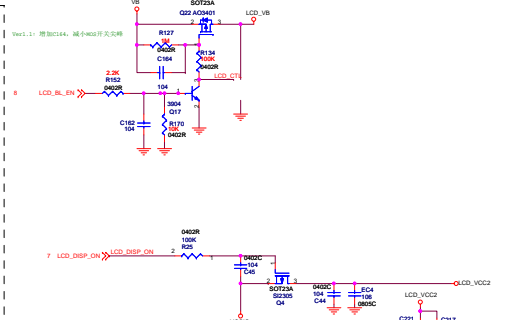
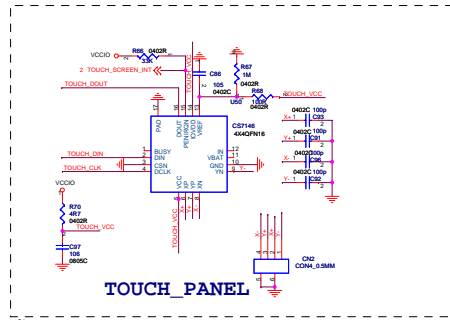

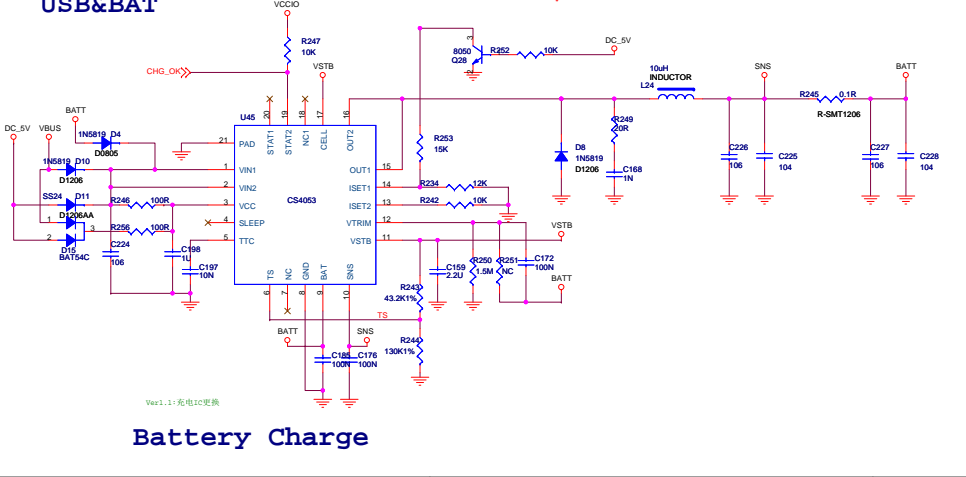
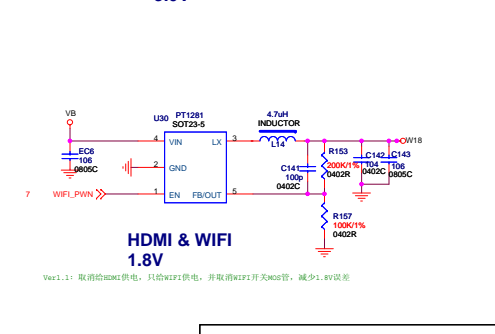
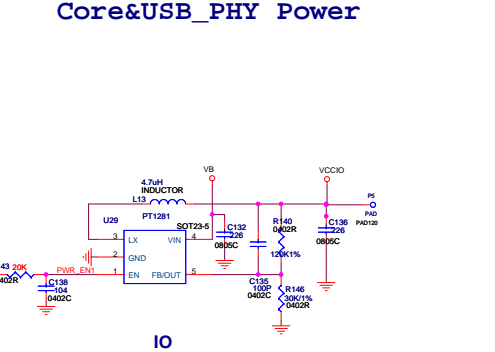
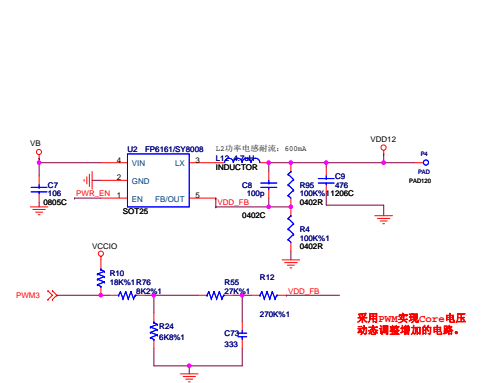
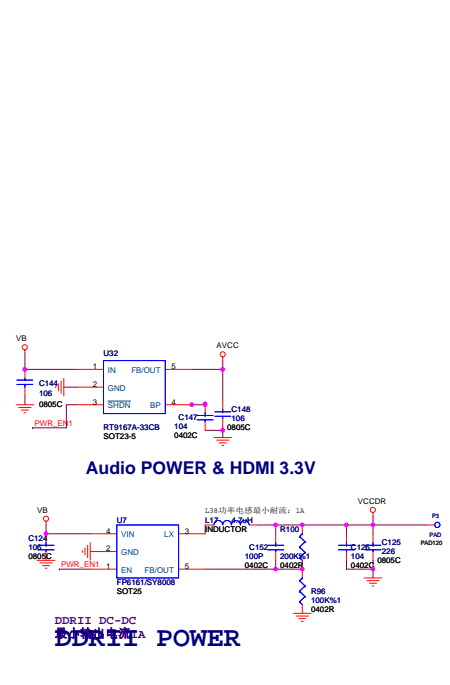
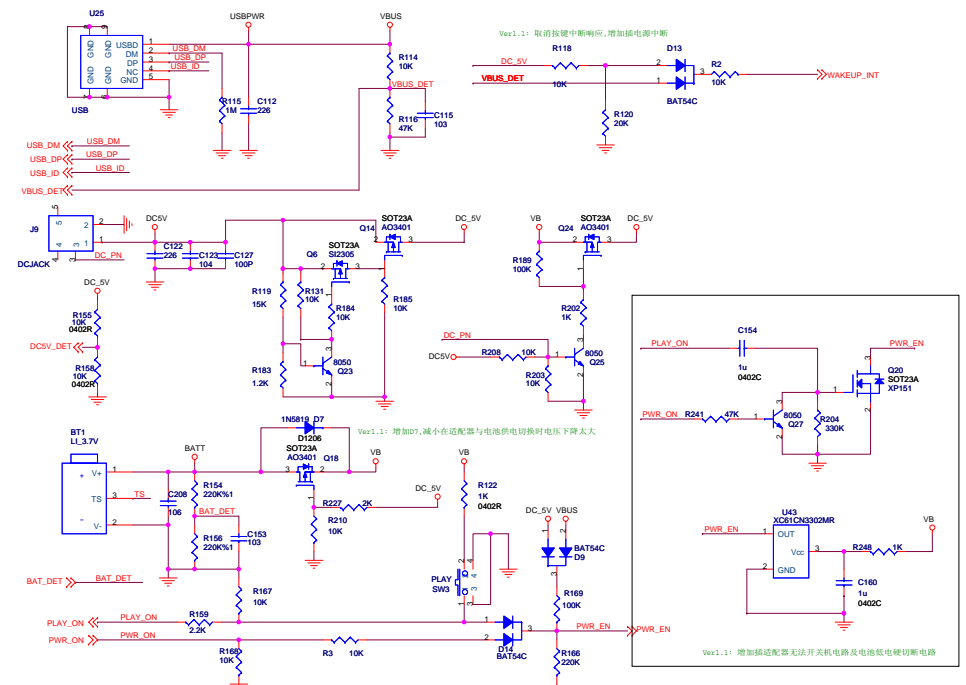

SHENZHEN YIFANG DIGITAL TECHNOLOGY CO., LTD.			
File	M730U		
Size	Document Number	POWER	Rev V1.0
Date:	Sunday, September 26, 2010	Sheet 6	of 7

Version	Date	Author	Change Note	Approved
V1.0			First edition	

GPIO

GPIO	FUNCTION	GPIO	FUNCTION	GPIO	FUNCTION	GPIO	FUNCTION
PA0	RECOVER	PB7	TOUCH_DOUT	PF3	SD0_DET	PG0	EVDO_ONOFF
PA1	SENSOR_PWDN	PE0	GSENSOR_INT	PF4	NAND_DETECT	PG1	EVDO_RST
PA2	JOG_LEFT	PE1	PLAY_ON_IDLE	PF5	PWM3(VDD ajust)	PG2	WIFI_CMD
PA3	JOG_RIGHT	PE2	WAKEUP_INT	PF7	SPK_CTL	PG3	WIFI_D0
PA4	WIFI_RST	PE3	TOUCH_SCREEN_INT	PH0	SD0_CMD	PG4	WIFI_D1
PB0	EVDO_POWERON	PE4	JOG_UP	PH1	SD_D0	PG5	WIFI_D2
PB1	WIFI_PWN	PE5	JOG_DOWN	PH2	SD_D1	PG6	WIFI_D3
PB2	KEY-LED	PE6	I2C1_SDA	PH3	SD_D2	PG7	WIFI_CLK
PB3	CHG_OK	PE7	I2C1_SCL	PH4	SD_D3	AIN0	BAT_DET
PB4	LCD_DISP_ON	PF0	UART1_RX	PH5	SD0_CLK	AIN1	AD_KEY
PB5	TOUCH_CLK	PF1	UART1_TX	PH6	LCD_BL_EN	AIN2	DC5V_DET
PB6	TOUCH_DIN	PF2	LED_PWM0	PH7	PWR_ON		

I2C1

设备:

- 1:Sensor
- 2:G_SENSOR MMA7660FC
- 3:RTC HYM8563 Address: read 0XA3H write 0XA2H
- 4:CODEC WM8988 Address:0X34H
- 5:HDMI ANX7150

备注: 1.红色字体的IO, 不能更改!!!
2.RK2818的PA口和PE口可以做中断输入口!

SHENZHEN YIFANG DIGITAL TECHNOLOGY CO.,LTD.		
Title M730U		
Size A	Document Number NOTE	Rev V1.0
Date: Wednesday, August 11, 2010		Sheet 7 of 7