



FCC PART 90 TEST REPORT

FCC Part 90

Report Reference No......: **TRE1301007601 R/C: 89798**

FCC ID.....: **S5XALK300-45**

Compiled by
 (position+printed name+signature)..: File administrators Jerome Luo

Jerome Luo

Supervised by
 (position+printed name+signature)..: Test Engineer Yuchao Wang

yuchao.wang

Approved by
 (position+printed name+signature)..: Manager Wenliang Li

Wenliang Li

Date of issue.....: Aug 23, 2013

Testing Laboratory Name: **Shenzhen Huatongwei International Inspection Co., Ltd**

Address.....: Keji Nan No.12 Road, Hi-tech Park, Shenzhen, China

Applicant's name: **VictelGlobal Communications Corporation Limited**

Address.....: FLAT/RM 803 8/F C C WU BLDG 302-308 HENNESSY RD
 WANCHAI, Hong Kong, China

Test specification:

Standard: **FCC Part 90: PRIVATE LAND MOBILE RADIO SERVICES**

TRF Originator.....: Shenzhen Huatongwei International Inspection CO., Ltd

Master TRF.....: Dated 2006-06

Shenzhen Huatongwei International Inspection Co., Ltd. All rights reserved.

This publication may be reproduced in whole or in part for non-commercial purposes as long as the Shenzhen Huatongwei International Inspection Co., Ltd is acknowledged as copyright owner and source of the material. Shenzhen Huatongwei International Inspection Co., Ltd takes no responsibility for and will not assume liability for damages resulting from the reader's interpretation of the reproduced material due to its placement and context.

Test item description: VictelGlobal KH Digital Transceiver

Trade Mark: **VictelGlobal**

Manufacturer: **Guangzhou Victel Technology Co., Ltd**

Model/Type reference.....: ALK300-45

Listed Models: /

Ratings.....: AC 120V/60Hz

Modulation: FM&4FSK

Channel Separation.....: 12.5KHz

Rated Power: 50 Watts(46.98dBm)/15 Watts(41.76dBm)

Operation Frequency Range: From 400 MHz to 470 MHz

Result.....: **Positive**

TEST REPORT

Test Report No. :	TRE1301007601	Aug 23, 2013
		Date of issue

Equipment under Test : VictelGlobal KH Digital Transceiver

Model /Type : ALK300-45

Listed Models : /

Applicant : **VictelGlobal Communications Corporation Limited**

Address : FLAT/RM 803 8/F C C WU BLDG 302-308 HENNESSY RD WANCHAI, Hong Kong, China

Manufacturer : **Guangzhou Victel Technology Co., Ltd**

Address : 13th Building, No.161 DongGuanZhuang Road, Tianhe District, Guangzhou, China

Test Result according to the standards on page 4:	Positive
--	-----------------

The test report merely corresponds to the test sample.
It is not permitted to copy extracts of these test result without the written permission of the test laboratory.

Contents

1.	<u>TEST STANDARDS</u>	4
2.	<u>SUMMARY</u>	5
2.1.	General Remarks	5
2.2.	Product Description	5
2.3.	Equipment under Test	5
2.4.	Short description of the Equipment under Test (EUT)	6
2.5.	EUT Configuration	6
2.6.	EUT operation mode	6
2.7.	EUT configuration	6
2.8.	Related Submittal(s) / Grant (s)	6
2.9.	Modifications	6
2.10.	Note	7
3.	<u>TEST ENVIRONMENT</u>	8
3.1.	Address of the test laboratory	8
3.2.	Test Facility	8
3.3.	Environmental conditions	9
3.4.	Configuration of Tested System	9
3.5.	Discription of Tested Modes	9
3.6.	Statement of the measurement uncertainty	9
3.7.	Test Description	10
3.8.	Equipments Used during the Test	10
4.	<u>TEST CONDITIONS AND RESULTS</u>	12
4.1.	Conducted Emissions Test	12
4.2.	Occupied Bandwidth and Emission Mask Test	17
4.3.	Transmitter Radiated Spurious Emssion	35
4.4.	Spurious Emssion on Antenna Port	42
4.5.	Modulation Charcateristics	74
4.6.	Frequency Stability Test	77
4.7.	Maximum Transmitter Power	79
4.8.	Transmitter Frequency Behavior	90
5.	<u>TEST SETUP PHOTOS OF THE EUT</u>	93
6.	<u>EXTERNAL AND INTERNAL PHOTOS OF THE EUT</u>	95

1. TEST STANDARDS

The tests were performed according to following standards:

[FCC Rules Part 90](#): PRIVATE LAND MOBILE RADIO SERVICES.

[TIA/EIA 603 D June 2010](#): Land Mobile FM or PM Communications Equipment Measurement and Performance Standards.

[47 CFR FCC Part 15 Subpart B](#): - Unintentional Radiators

[FCC Part 2](#): FREQUENCY ALLOCATIONS AND RADIO TREATY MATTERS; GENERAL RULES AND REGULATIONS

2. SUMMARY

2.1. General Remarks

Date of receipt of test sample	:	Jan 20, 2013
Testing commenced on	:	Jan 20, 2013
Testing concluded on	:	Aug 23, 2013

2.2. Product Description

The **VictelGlobal Communications Corporation Limited.**'s Model: ALK300-45 or the "EUT" as referred to in this report; more general information as follows, for more details, refer to the user's manual of the EUT.

Name of EUT	VictelGlobal KH Digital Transceiver	
Model Number	ALK300-45	
FCC ID	SSXALK300-45	
Rated Output Power	50 Watts(46.98dBm)/15 Watts(41.76dBm)	
Support data rate	9.6kbps	
Modulation Type	FM for Analog Voice	
	4FSK for Digital Voice/Digital Data	
	4FSK for Digital Data	
	Analog	11K0F3E for 12.5KHz Channel Separation
Digital	7K60FXD for Digital Data only	
	7K60FXW for Digital Data & Digital Voice	
Channel Separation	Analog	12.5KHz
	Digital Voice/Data	12.5KHz
	Digital Data	12.5KHz
Antenna Type	External	
Frequency Range	From 400 MHz to 470 MHz	
Maximum Transmitter Power	Analog	57.67W for 12.5 KHz Channel Separation
	Digital	57.15W for 12.5 KHz Channel Separation

Note: The product has the same digital working characters when operating in both two digitized voice/data mode (7K60FXD and 7K60FXW). So only one set of test results for digital modulation modes are provided in this test report.

2.3. Equipment under Test

Power supply system utilised

Power supply voltage	:	<input checked="" type="radio"/> 120V / 60 Hz	<input type="radio"/> 115V / 60Hz
		<input type="radio"/> 12 V DC	<input type="radio"/> 24 V DC
		<input type="radio"/> Other (specified in blank below)	

Test frequency list

Modulation Type	Test Channel	Test Frequency
Analog/FM	Low	406.5000 MHz
	Low	418.0000 MHz
	Middle	435.5000 MHz
	High	453.0000 MHz
	High	469.5000 MHz
Digital/4FSK	Low	406.5000 MHz
	Low	418.0000 MHz
	Middle	435.5000 MHz
	High	453.0000 MHz
	High	469.5000 MHz

2.4. Short description of the Equipment under Test (EUT)

400-470 MHz U frequency band VictelGlobal KH Digital Transceiver.

For more details, refer to the user's manual of the EUT.

Serial number: Prototype

2.5. EUT Configuration

The EUT configuration for testing is installed on RF field strength measurement to meet the Commission's requirement and operating in a manner which intends to maximize its emission characteristics in a continuous normal application.

2.6. EUT operation mode

The EUT has been tested under typical operating condition and The Transmitter was operated in the normal operating mode. The TX frequency was fixed which was for the purpose of the measurements.

2.7. EUT configuration

The following peripheral devices and interface cables were connected during the measurement:

- supplied by the manufacturer
- supplied by the lab

<input type="radio"/>	Power Cable	Length (m) :	/
		Shield :	/
		Detachable :	/
<input type="radio"/>	Multimeter	Manufacturer :	/
		Model No. :	/

2.8. Related Submittal(s) / Grant (s)

This submittal(s) (test report) is intended for FCC ID: **S5XALK300-45** filing to comply with FCC Part 90 Rules

2.9. Modifications

No modifications were implemented to meet testing criteria.

2.10. Note

1. The EUT is a U frequency band (400-470MHz) VitelGlobal KH Digital Transceiver, The functions of the EUT listed as below:

	Test Standards	Reference Report
Radio	FCC Part 90	TRE1301007601
MPE	Oet 65	TRE1301007602

3. TEST ENVIRONMENT

3.1. Address of the test laboratory

Shenzhen Huatongwei International Inspection Co., Ltd
Keji Nan No.12 Road, Hi-tech Park, Shenzhen, China
Phone: 86-755-26715686 Fax: 86-755-26748089

The sites are constructed in conformance with the requirements of ANSI C63.7, ANSI C63.4 (2009) and CISPR Publication 22.

3.2. Test Facility

The test facility is recognized, certified, or accredited by the following organizations:

CNAS-Lab Code: L1225

Shenzhen Huatongwei International Inspection Co., Ltd has been assessed and proved to be in compliance with CNAS-CL01 Accreditation Criteria for Testing and Calibration Laboratories (identical to ISO/IEC 17025: 2005 General Requirements) for the Competence of Testing and Calibration Laboratories, Date of Registration: Mar 01, 2012. Valid time is until Feb 28, 2015.

A2LA-Lab Cert. No. 2243.01

Shenzhen Huatongwei International Inspection Co., Ltd, EMC Laboratory has been accredited by A2LA for technical competence in the field of electrical testing, and proved to be in compliance with ISO/IEC 17025: 2005 General Requirements for the Competence of Testing and Calibration Laboratories and any additional program requirements in the identified field of testing. Valid time is until Sept 30, 2013.

FCC-Registration No.: 662850

Shenzhen Huatongwei International Inspection Co., Ltd, EMC Laboratory has been registered and fully described in a report filed with the FCC (Federal Communications Commission). The acceptance letter from the FCC is maintained in our files. Registration 662850, Renewal date June 01, 2015.

IC-Registration No.: 5377

The 3m Alternate Test Site of Shenzhen Huatongwei International Inspection Co., Ltd has been registered by Certification and Engineering Bureau of Industry Canada for the performance of radiated measurements with Registration No. 5377 on Jan 25, 2011. Valid time is until Jan 24, 2014

ACA

Shenzhen Huatongwei International Inspection Co., Ltd, EMC Laboratory can also perform testing for the Australian C-Tick mark as a result of our A2LA accreditation.

VCCI

The 3m Semi-anechoic chamber (12.2m×7.95m×6.7m) and Shielded Room (8m×4m×3m) of Shenzhen Huatongwei International Inspection Co., Ltd has been registered in accordance with the Regulations for Voluntary Control Measures with Registration No.: R-2484. Date of Registration: December 20, 2009. Valid time is until December 19, 2013.

Main Ports Conducted Interference Measurement of Shenzhen Huatongwei International Inspection Co., Ltd has been registered in accordance with the Regulations for Voluntary Control Measures with Registration No.: C-2726. Date of Registration: December 20, 2009. Valid time is until December 19, 2013.

DNV

Shenzhen Huatongwei International Inspection Co Ltd has been found to comply with the requirements of DNV towards subcontractor of EMC and safety testing services in conjunction with the EMC and Low voltage Directives and in the voluntary field. The acceptance is based on a formal quality Audit and follow-ups according to relevant parts of ISO/IEC Guide 17025(2005), in accordance with the requirements of the DNV Laboratory Quality Manual towards subcontractors. Valid time is until Aug 24, 2016.

3.3. Environmental conditions

During the measurement the environmental conditions were within the listed ranges:

Temperature:	15-35 ° C
Humidity:	30-60 %
Atmospheric pressure:	950-1050mbar

3.4. Configuration of Tested System

Fig. 2-1 Configuration of Tested System

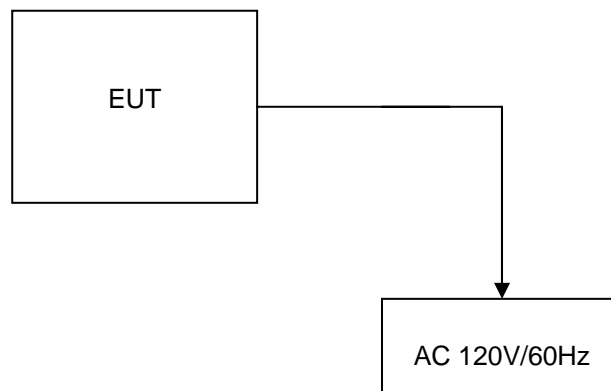

Table 2-1 Equipment Used in Tested System

3.5. Discription of Tested Modes

The EUT has been tested under normal operating condition. Five channels (the high, the middle and the low) are chosen for testing at each channel separation (12.5 KHz).

3.6. Statement of the measurement uncertainty

The data and results referenced in this document are true and accurate. The reader is cautioned that there may be errors within the calibration limits of the equipment and facilities. The measurement uncertainty was calculated for all measurements listed in this test report acc. to CISPR 16 - 4 „Specification for radio disturbance and immunity measuring apparatus and methods – Part 4: Uncertainty in EMC Measurements“ and is documented in the Shenzhen Huatongwei International Inspection Co., Ltd quality system acc. to DIN EN ISO/IEC 17025. Furthermore, component and process variability of devices similar to that tested may result in additional deviation. The manufacturer has the sole responsibility of continued compliance of the device.

Hereafter the best measurement capability for Shenzhen Huatongwei laboratory is reported:

Test Items	Measurement Uncertainty	Notes
Frequency stability	25 Hz	(1)
Transmitter power conducted	0.57 dB	(1)
Transmitter power Radiated	2.20 dB	(1)
Conducted spurious emission 9KHz-12.75 GHz	1.60 dB	(1)
Conducted Emission 9KHz-30MHz	3.39 dB	(1)
Radiated Emission 30~1000MHz	4.24 dB	(1)
Radiated Emissio 1~18GHz	5.16 dB	(1)
Radiated Emissio 18-40GHz	5.54 dB	(1)
Occupied Bandwidth	-----	(1)
Emission Mask	-----	(1)
Modulation Characteristic	-----	(1)
Transmitter Frequency Behavior	-----	(1)

- (1) This uncertainty represents an expanded uncertainty expressed at approximately the 95% confidence level using a coverage factor of k=1.96.

3.7. Test Description

ETSI EN 300 219-1/-2 requirements		
Conducted Emission	§ 15.107	PASS
Receiver Radiated Spurious Emssion	§ 15.109	N/A ^[2]
Receiver Conducted Spurious Emssion	§ 15.109	N/A ^[2]
Maximum Transmitter Power	§ 90.205	PASS
Modulation Characteristic	§ 90.207	PASS
Occupied Bandwidth	§ 90.209	PASS
Emission Mask	§ 90.210	PASS
Frequency Stability	§ 90.213	PASS
Transmitter Frequency Behavior	§ 90.214	PASS
Transmitter Radiated Spurious Emssion	§ 90.210	PASS
Spurious Emssion On Antenna Port	§ 90.210	PASS

- Remark:1.The product was continuous transmitter after receive signal to activate transmitter;
 2.The product can not state only receiver mode and the product was continuous transmitter after receive signal to activate transmitter;
 3.The measurement uncertainty is not included in the test result.

3.8. Equipments Used during the Test

AC Power Conducted Emission				
Name of Equipment	Manufacturer	Model	Serial Number	Calibration Due
Artificial Mains	Rohde&Schwarz	ESH2-Z5	100028	10/27/2013
EMI Test Receiver	Rohde&Schwarz	ESCS 30	100038	10/27/2013
Pulse Limiter	Rohde&Schwarz	ESHSZ2	100044	10/27/2013
EMI Test Software	Rohde&Schwarz	ES-K1 V1.71	N/A	N/A
RF COMMUNICATION TEST SET	HP	8920A	3813A10206	10/27/2013

Modulation Characteristic				
Name of Equipment	Manufacturer	Model	Serial Number	Calibration Due
RF COMMUNICATION TEST SET	HP	8920A	3813A10206	10/27/2013

Frequency Stability				
Name of Equipment	Manufacturer	Model	Serial Number	Calibration Due
RF COMMUNICATION TEST SET	HP	8920A	3813A10206	10/27/2013
Signal Generator	Rohde&Schwarz	SMT03	100059	10/27/2013
Climate Chamber	ESPEC	EL-10KA	05107008	10/27/2013

Transmitter Radiated Spurious Emission				
Name of Equipment	Manufacturer	Model	Serial Number	Calibration Due
Ultra-Broadband Antenna	Rohde&Schwarz	HL562	100015	10/27/2013
EMI Test Receiver	Rohde&Schwarz	ESI 26	100009	10/27/2013
RF Test Panel	Rohde&Schwarz	TS / RSP	335015/ 0017	N/A
HORN ANTENNA	Rohde&Schwarz	HF906	100039	10/27/2013
Turntable	ETS	2088	2149	N/A
Antenna Mast	ETS	2075	2346	N/A
EMI Test Software	Rohde&Schwarz	ES-K1 V1.71	N/A	N/A
RF COMMUNICATION TEST SET	HP	8920A	3813A10206	10/27/2013
Ultra-Broadband Antenna	ShwarzBeck	VULB9163	538	10/27/2013
Ultra-Broadband Antenna	ShwarzBeck	VULB9163	539	10/27/2013
HORN ANTENNA	ShwarzBeck	9120D	1012	10/27/2013
HORN ANTENNA	ShwarzBeck	9120D	1011	10/27/2013
TURNTABLE	MATURO	TT2.0	----	N/A
ANTENNA MAST	MATURO	TAM-4.0-P	----	N/A

Maximum Transmitter Power & Spurious Emission On Antenna Port & Occupied Bandwidth & Emission Mask				
Name of Equipment	Manufacturer	Model	Serial Number	Calibration Due
Receiver	Rohde&Schwarz	ESI 26	100009	10/27/2013
Attenuator	R&S	ESH3-22	100449	10/27/2013
RF COMMUNICATION TEST SET	HP	8920A	3813A10206	10/27/2013
High-Pass Filter	Anritsu	MP526B	6220875256	10/27/2013
High-Pass Filter	Anritsu	MP526D	6220878392	10/27/2013
Spectrum Analyzer	Aglient	E4407B	MY44210775	10/27/2013
Spectrum Analyzer	Rohde&Schwarz	FSP40	1164.4391.40	10/27/2013

Transient Frequency Behavior				
Name of Equipment	Manufacturer	Model	Serial Number	Calibration Due
Signal Generator	Rohde&Schwarz	SMT03	100059	10/27/2013
Storage Oscilloscope	Tektronix	TDS3054B	B033027	10/27/2013
RF COMMUNICATION TEST SET	HP	8920A	3813A10206	10/27/2013

The calibration interval was one year.

4. TEST CONDITIONS AND RESULTS

4.1. Conducted Emissions Test

TEST APPLICABLE

The EUT was tested according to ANSI C63.4 - 2009. The frequency spectrum from 0.15 MHz to 30 MHz was investigated. The LISN used was 50 ohm / 50 u Henry as specified by section 5.1 of ANSI C63.4 - 2009. Cables and peripherals were moved to find the maximum emission levels for each frequency.

TEST CONFIGURATION

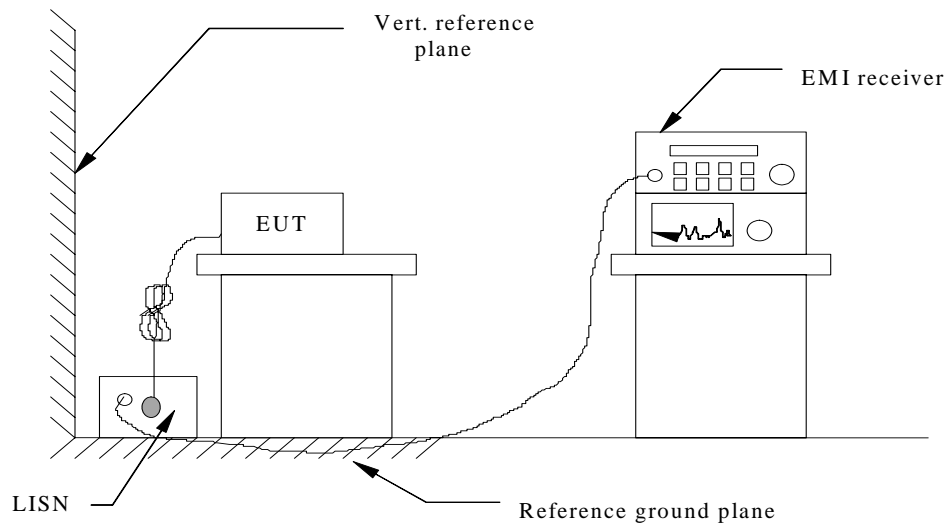

TEST PROCEDURE

- 1 The equipment was set up as per the test configuration to simulate typical actual usage per the user's manual. The EUT is a tabletop system; a wooden table with a height of 0.8 meters is used and is placed on the ground plane as per ANSI C63.4-2009.
- 2 Support equipment, if needed, was placed as per ANSI C63.4-2009.
- 3 All I/O cables were positioned to simulate typical actual usage as per ANSI C63.4-2009.
- 4 If a EUT received DC power from the adapter, the adapter received AC120V/60Hz power through a Line Impedance Stabilization Network (LISN) which supplied power source and was grounded to the ground plane.
- 5 All support equipments received AC power from a second LISN, if any.
- 6 The EUT test program was started. Emissions were measured on each current carrying line of the EUT using a spectrum Analyzer / Receiver connected to the LISN powering the EUT. The LISN has two monitoring points: Line 1 (Hot Side) and Line 2 (Neutral Side). Two scans were taken: one with Line 1 connected to Analyzer / Receiver and Line 2 connected to a 50 ohm load; the second scan had Line 1 connected to a 50 ohm load and Line 2 connected to the Analyzer / Receiver.
- 7 Analyzer / Receiver scanned from 150 KHz to 30MHz for emissions in each of the test modes.
- 8 During the above scans, the emissions were maximized by cable manipulation.

Conducted Power Line Emission Limit

For unintentional device, according to § 15.107(a) Line Conducted Emission Limits is as following :

Frequency (MHz)	Maximum RF Line Voltage (dBµV)			
	CLASS A		CLASS B	
	Q.P.	Ave.	Q.P.	Ave.
0.15 - 0.50	79	66	66-56*	56-46*
0.50 - 5.00	73	60	56	46
5.00 - 30.0	73	60	60	50

* Decreasing linearly with the logarithm of the frequency

For intentional device, according to §15.207(a) Line Conducted Emission Limit is same as above table.

TEST RESULTS

For FM Modulation @ 12.5 KHz TX Mode

SCAN TABLE: "Voltage (9K-30M) FIN"
 Short Description: 150K-30M Voltage

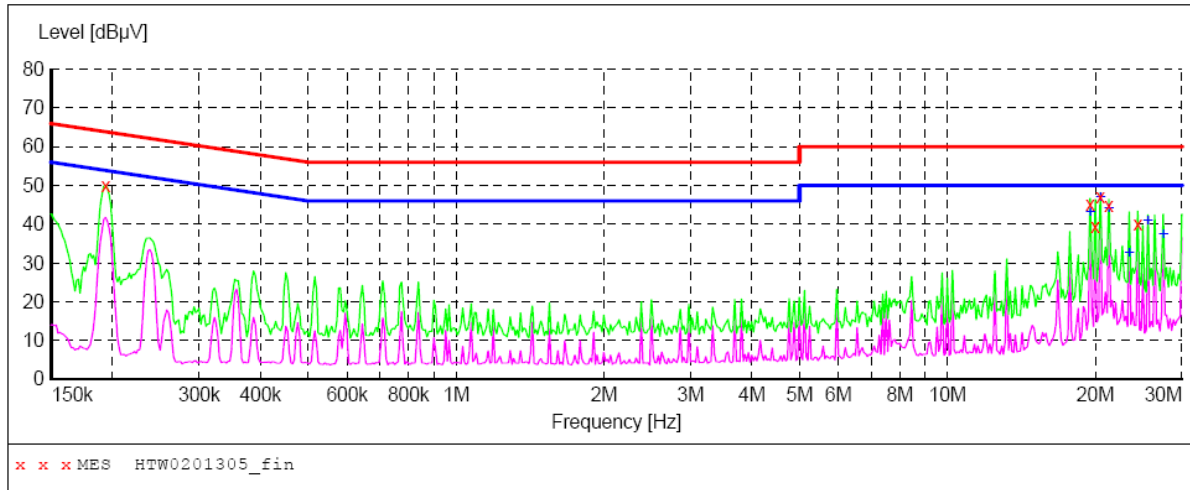

MEASUREMENT RESULT: "HTW0201305_fin"

2/1/2013 10:45AM

Frequency MHz	Level dBµV	Transd dB	Limit dBµV	Margin dB	Detector	Line	PE
0.193556	50.00	10.1	64	13.9	QP	N	GND
19.519839	45.10	10.9	60	14.9	QP	N	GND
19.992077	39.30	10.9	60	20.7	QP	N	GND
20.475736	47.10	10.9	60	12.9	QP	N	GND
21.307971	44.90	10.9	60	15.1	QP	N	GND
24.398952	40.20	11.0	60	19.8	QP	N	GND

MEASUREMENT RESULT: "HTW0201305_fin2"

2/1/2013 10:45AM

Frequency MHz	Level dBµV	Transd dB	Limit dBµV	Margin dB	Detector	Line	PE
19.519839	43.20	10.9	50	6.8	AV	N	GND
20.475736	47.10	10.9	50	2.9	AV	N	GND
21.307971	44.30	10.9	50	5.7	AV	N	GND
23.445989	32.60	11.0	50	17.4	AV	N	GND
25.593775	41.00	11.0	50	9.0	AV	N	GND
27.496607	37.50	11.0	50	12.5	AV	N	GND

SCAN TABLE: "Voltage (9K-30M)FIN"
 Short Description: 150K-30M Voltage

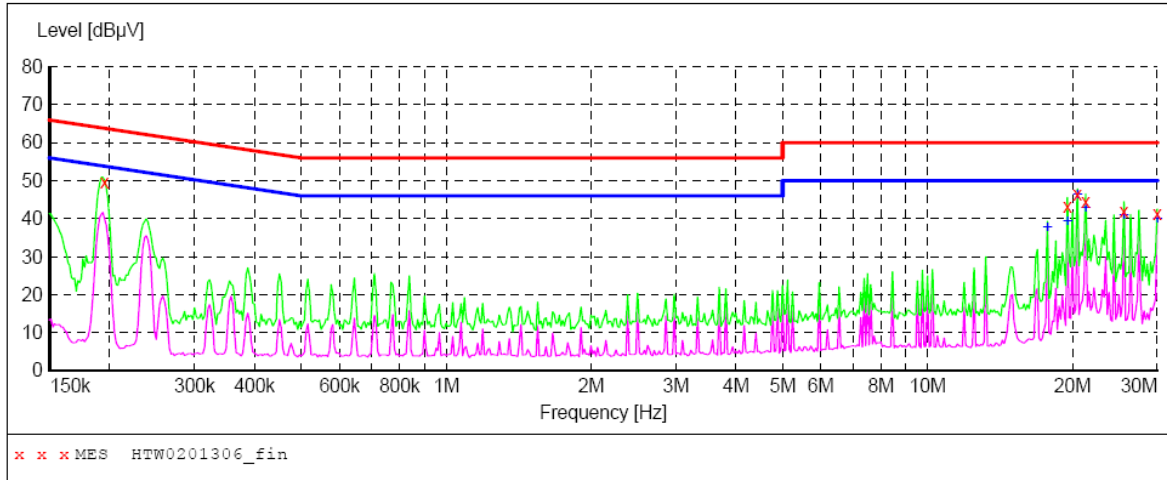

MEASUREMENT RESULT: "HTW0201306_fin"

2/1/2013 10:51AM

Frequency MHz	Level dBµV	Transd dB	Limit dBµV	Margin dB	Detector	Line	PE
0.195105	49.50	10.1	64	14.3	QP	L1	GND
19.519839	43.10	10.9	60	16.9	QP	L1	GND
20.475736	46.50	10.9	60	13.5	QP	L1	GND
21.307971	44.50	10.9	60	15.5	QP	L1	GND
25.593775	41.80	11.0	60	18.2	QP	L1	GND
30.000000	41.30	11.1	60	18.7	QP	L1	GND

MEASUREMENT RESULT: "HTW0201306_fin2"

2/1/2013 10:51AM

Frequency MHz	Level dBµV	Transd dB	Limit dBµV	Margin dB	Detector	Line	PE
17.739842	37.70	10.8	50	12.3	AV	L1	GND
19.519839	39.30	10.9	50	10.7	AV	L1	GND
20.475736	46.40	10.9	50	3.6	AV	L1	GND
21.307971	43.00	10.9	50	7.0	AV	L1	GND
25.593775	41.10	11.0	50	8.9	AV	L1	GND
30.000000	40.20	11.1	50	9.8	AV	L1	GND

For 4FSK Modulation @ 12.5 KHz TX Mode

SCAN TABLE: "Voltage (9K-30M) FIN"

Short Description: 150K-30M Voltage

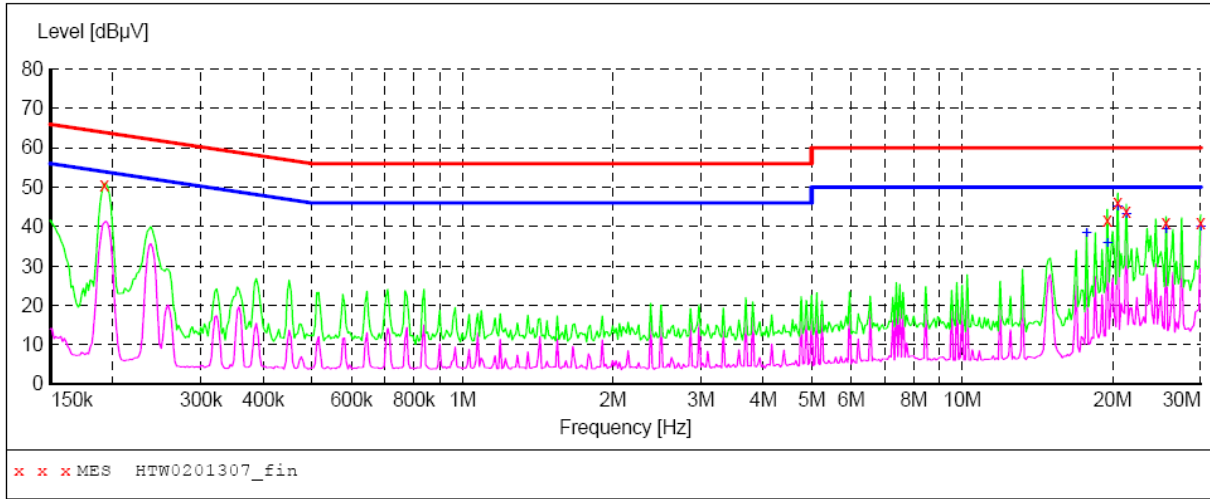

MEASUREMENT RESULT: "HTW0201307_fin"

2/1/2013 10:58AM

Frequency MHz	Level dBµV	Transd dB	Limit dBµV	Margin dB	Detector	Line	PE
0.192020	50.50	10.1	64	13.4	QP	L1	GND
19.519839	41.60	10.9	60	18.4	QP	L1	GND
20.475736	46.00	10.9	60	14.0	QP	L1	GND
21.307971	44.00	10.9	60	16.0	QP	L1	GND
25.593775	41.10	11.0	60	18.9	QP	L1	GND
30.000000	40.90	11.1	60	19.1	QP	L1	GND

MEASUREMENT RESULT: "HTW0201307_fin2"

2/1/2013 10:58AM

Frequency MHz	Level dBµV	Transd dB	Limit dBµV	Margin dB	Detector	Line	PE
17.739842	38.40	10.8	50	11.6	AV	L1	GND
19.519839	35.90	10.9	50	14.1	AV	L1	GND
20.475736	45.10	10.9	50	4.9	AV	L1	GND
21.307971	43.40	10.9	50	6.6	AV	L1	GND
25.593775	39.50	11.0	50	10.5	AV	L1	GND
30.000000	40.20	11.1	50	9.8	AV	L1	GND

SCAN TABLE: "Voltage (9K-30M)FIN"

Short Description: 150K-30M Voltage

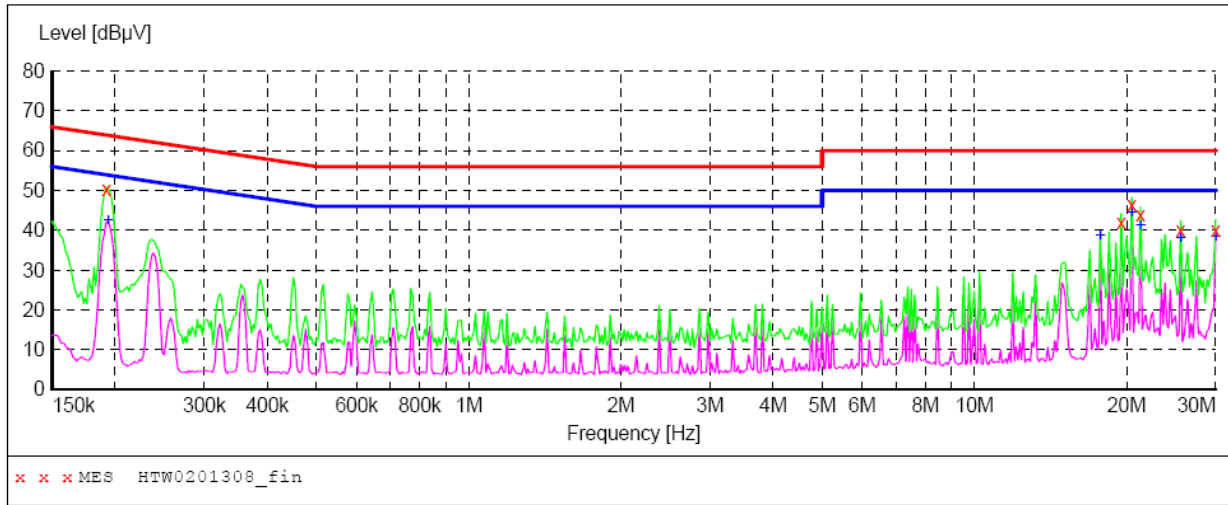

MEASUREMENT RESULT: "HTW0201308_fin"

2/1/2013 11:04AM

Frequency MHz	Level dBµV	Transd dB	Limit dBµV	Margin dB	Detector	Line	PE
0.192024	50.30	10.1	64	13.6	QP	N	GND
19.519839	41.80	10.9	60	18.2	QP	N	GND
20.475736	46.40	10.9	60	13.6	QP	N	GND
21.307971	43.80	10.9	60	16.2	QP	N	GND
25.593775	40.00	11.0	60	20.0	QP	N	GND
30.000000	40.20	11.1	60	19.8	QP	N	GND

MEASUREMENT RESULT: "HTW0201308_fin2"

2/1/2013 11:04AM

Frequency MHz	Level dBµV	Transd dB	Limit dBµV	Margin dB	Detector	Line	PE
0.193560	42.50	10.1	54	11.4	AV	N	GND
17.739842	38.80	10.8	50	11.2	AV	N	GND
20.475736	44.40	10.9	50	5.6	AV	N	GND
21.307971	41.20	10.9	50	8.8	AV	N	GND
25.593775	38.00	11.0	50	12.0	AV	N	GND
30.000000	38.50	11.1	50	11.5	AV	N	GND

4.2. Occupied Bandwidth and Emission Mask Test

TEST APPLICABLE

- (a). Occupied Bandwidth: The EUT was connected to the audio signal generator and the spectrum analyzer via the main RF connector, and through an appropriate attenuator. The EUT was controlled to transmit its maximum power. Then the bandwidth of 99% power can be measured by the spectrum analyzer.
- (b). Emission Mask B: For transmitters that are equipped with an audio low-pass filter pursuant to §90.211(a), the power of any emission must be below the unmodulated carrier power (P) as follows:
- (1) On any frequency removed from the assigned frequency by more than 50 percent, but not more than 100 percent of the authorized bandwidth: At least 25 dB.
 - (2) On any frequency removed from the assigned frequency by more than 100 percent, but not more than 250 percent of the authorized bandwidth: At least 35 dB.
 - (3) On any frequency removed from the assigned frequency by more than 250 percent of the authorized bandwidth: At least $43 + 10 \log (P)$ dB.
- (c). Emission Mask D, 12.5 kHz channel bandwidth equipment: For transmitters designed to operate with a 12.5 kHz channel bandwidth, any emission must be attenuated below the power (P) of the highest emission contained within the authorized bandwidth as follows:
- (1) On any frequency from the center of the authorized bandwidth f_0 to 5.625 kHz removed from f_0 : Zero dB.
 - (2) On any frequency removed from the center of the authorized bandwidth by a displacement frequency (f_d in kHz) of more than 5.625 kHz but no more than 12.5 kHz: At least $7.27(f_d - 2.88 \text{ kHz})$ dB.
 - (3) On any frequency removed from the center of the authorized bandwidth by a displacement frequency (f_d in kHz) of more than 12.5 kHz: At least $50 + 10 \log (P)$ dB or 70 dB, whichever is the lesser attenuation.

TEST CONFIGURATION

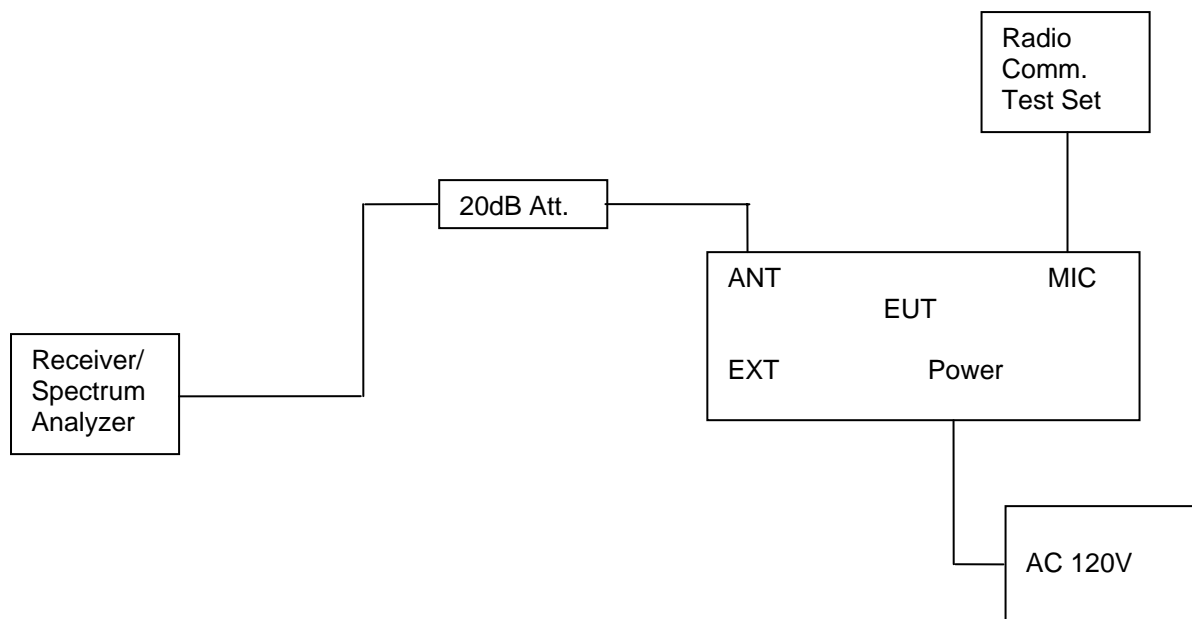

TEST PROCEDURE

1. The EUT was placed on a turn table which is 0.8m above ground plane.
2. The EUT was modulated by 2.5 KHz Sine wave audio signal; the level of the audio signal employed is 16 dB greater than that necessary to produce 50% of rated system deviation. Rated system deviation is 2.5 kHz (12.5 kHz channel spacing) and 5 kHz (25 kHz channel spacing).
3. Set EUT as normal operation.
4. Set SPA Center Frequency = fundamental frequency, RBW=300Hz, VBW= 3 KHz, span =50 KHz.
5. Set SPA Max hold. Mark peak, Set 99% Occupied Bandwidth and 26dB Occupied Bandwidth.
6. Set SPA Center Frequency=fundamental frequency, set =300Hz, VBW=3 KHz, span=50 KHz for 12.5 channel spacing.

TEST RESULTS

4.2.1 Occupied Bandwidth

Modulation Type	Channel Separation	Test Channel	Test Frequency	99% Occupied Bandwidth	26dB Occupied Band width
FM	12.5KHz	Low	406.5000 MHz	9.80 KHz	10.60 KHz
		Low	418.0000 MHz	9.70 KHz	10.50 KHz
		Middle	435.5000 MHz	9.70 KHz	10.60 KHz
		High	453.0000 MHz	9.70 KHz	10.50 KHz
		High	469.5000 MHz	9.60 KHz	10.50 KHz
4FSK	12.5KHz	Low	406.5000 MHz	7.60 KHz	10.10 KHz
		Low	418.0000 MHz	8.00 KHz	10.30 KHz
		Middle	435.5000 MHz	7.60 KHz	10.20 KHz
		High	453.0000 MHz	7.80 KHz	10.10 KHz
		High	469.5000 MHz	7.70 KHz	9.40 KHz
Limit		11.25KHz for 12.5KHz Channel Separation			
Test Results		Compliance			

Plots of 99% and 26dB Bandwidth Measurement

Modulation Type	Channel Separation	Freq.(MHz)	99% Bandwidth (KHz)	26dB Bandwidth (KHz)	FCC Limit (KHz)	Results
FM	12.5 KHz	406.5000	9.80	10.60	11.25	Compliance

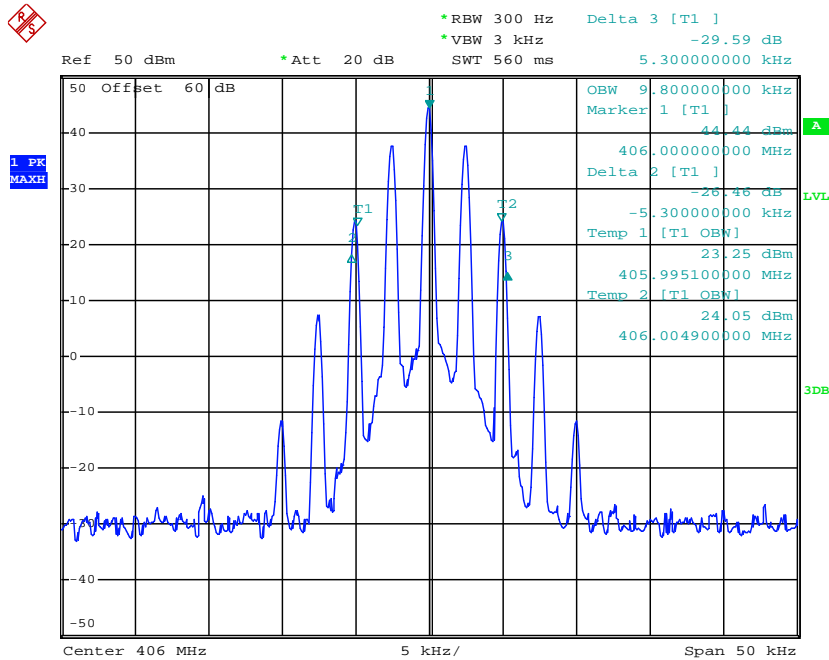

Date: 5.FEB.2013 10:12:39

Modulation Type	Channel Separation	Freq.(MHz)	99% Bandwidth (KHz)	26dB Bandwidth (KHz)	FCC Limit (KHz)	Results
FM	12.5 KHz	418.0000	9.70	10.50	11.25	Complicance

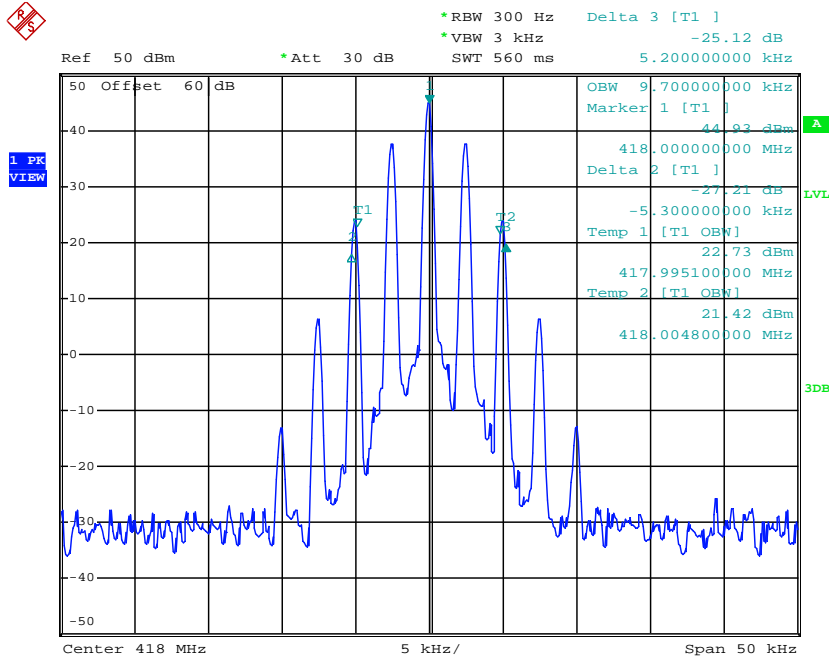

Date: 5.FEB.2013 10:10:27

Modulation Type	Channel Separation	Freq.(MHz)	99% Bandwidth (KHz)	26dB Bandwidth (KHz)	FCC Limit (KHz)	Results
FM	12.5 KHz	435.5000	9.70	10.60	11.25	Complicance

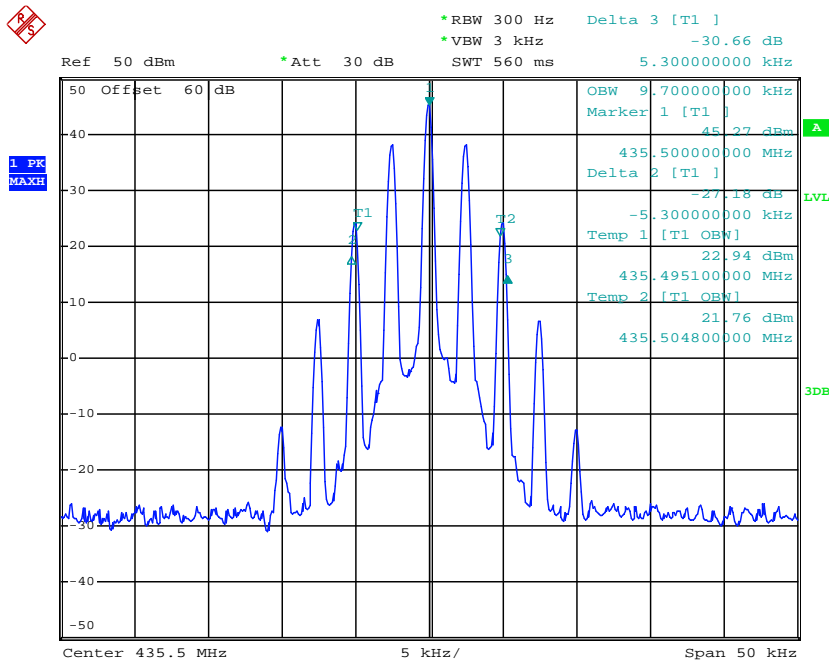

Date: 5.FEB.2013 10:05:01

Modulation Type	Channel Separation	Freq.(MHz)	99% Bandwidth (KHz)	26dB Bandwidth (KHz)	FCC Limit (KHz)	Results
FM	12.5 KHz	453.0000	9.70	10.50	11.25	Complicance

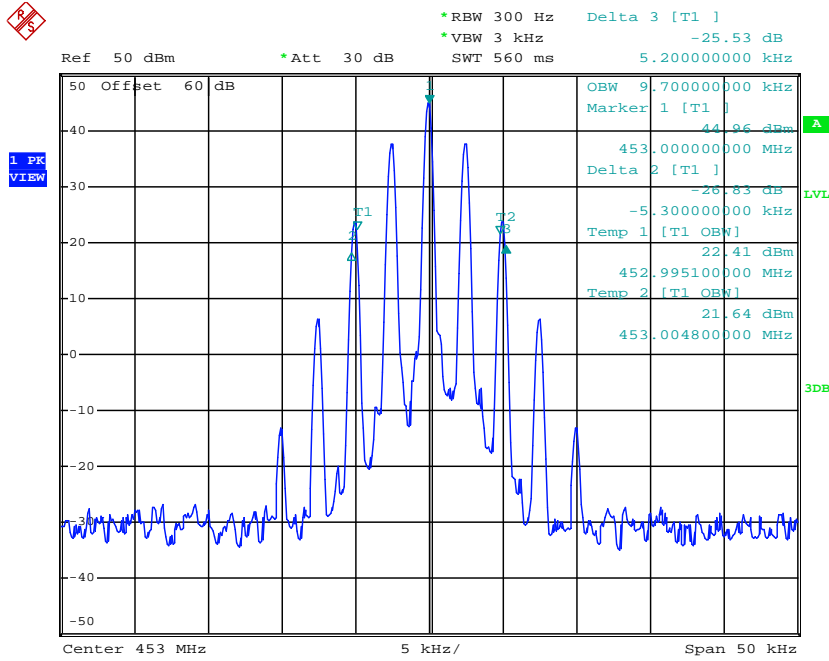

Date: 5.FEB.2013 10:08:53

Modulation Type	Channel Separation	Freq.(MHz)	99% Bandwidth (KHz)	26dB Bandwidth (KHz)	FCC Limit (KHz)	Results
FM	12.5 KHz	469.5000	9.60	10.50	11.25	Complicance

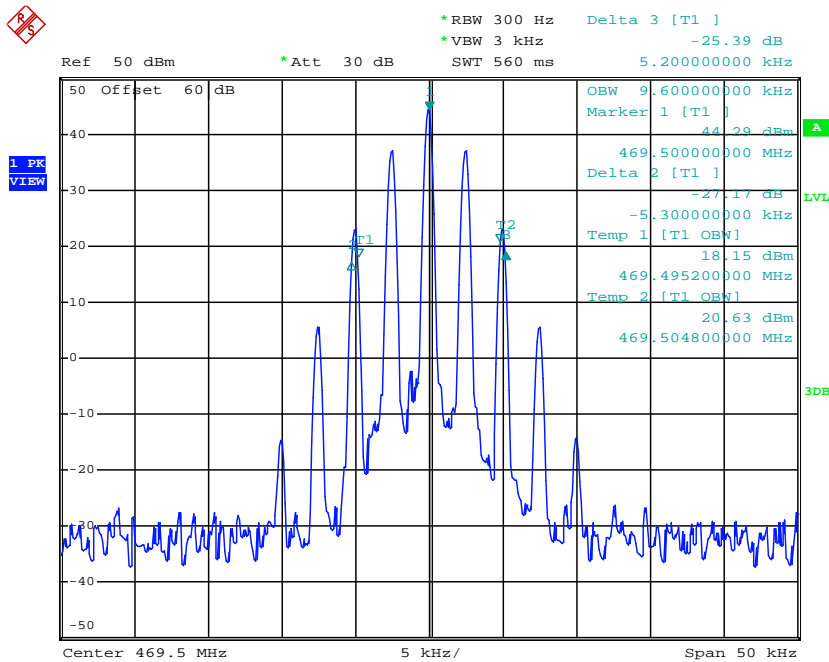

Date: 5.FEB.2013 10:06:47

Modulation Type	Channel Separation	Freq.(MHz)	99% Bandwidth (KHz)	26dB Bandwidth (KHz)	FCC Limit (KHz)	Results
4FSK	12.5 KHz	406.5000	7.60	10.10	11.25	Complicance

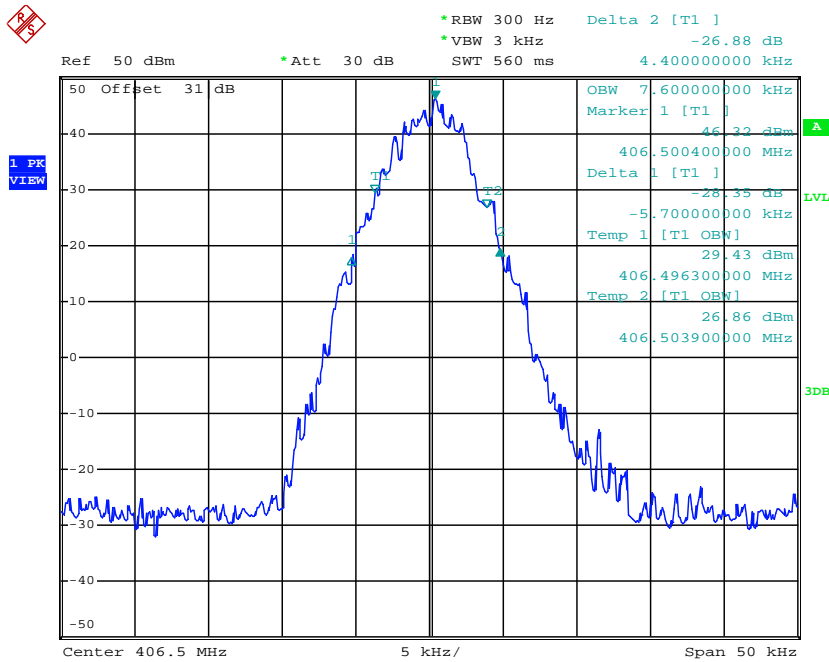

Date: 30.JAN.2013 16:42:41

Modulation Type	Channel Separation	Freq.(MHz)	99% Bandwidth (KHz)	26dB Bandwidth (KHz)	FCC Limit (KHz)	Results
4FSK	12.5 KHz	418.0000	8.00	10.30	11.25	Complicance

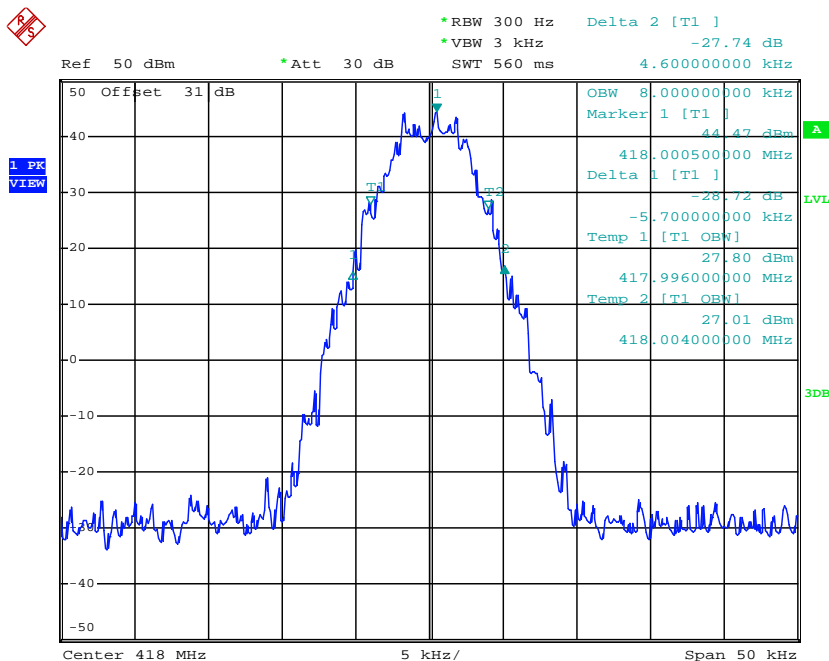

Date: 30.JAN.2013 16:41:27

Modulation Type	Channel Separation	Freq.(MHz)	99% Bandwidth (KHz)	26dB Bandwidth (KHz)	FCC Limit (KHz)	Results
4FSK	12.5 KHz	435.5000	7.60	10.20	11.25	Complicance

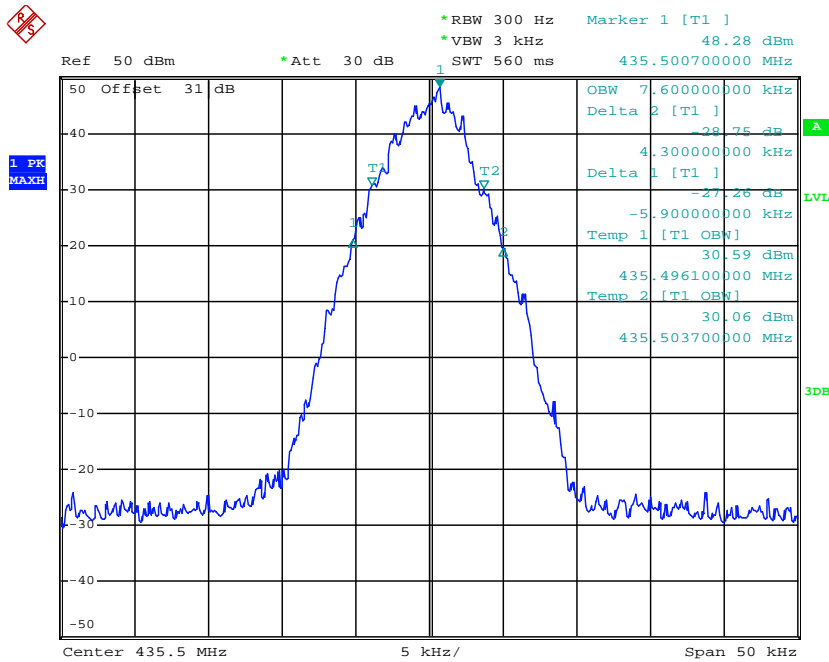

Date: 30.JAN.2013 16:38:17

Modulation Type	Channel Separation	Freq.(MHz)	99% Bandwidth (KHz)	26dB Bandwidth (KHz)	FCC Limit (KHz)	Results
4FSK	12.5 KHz	453.0000	7.80	10.10	11.25	Complicance

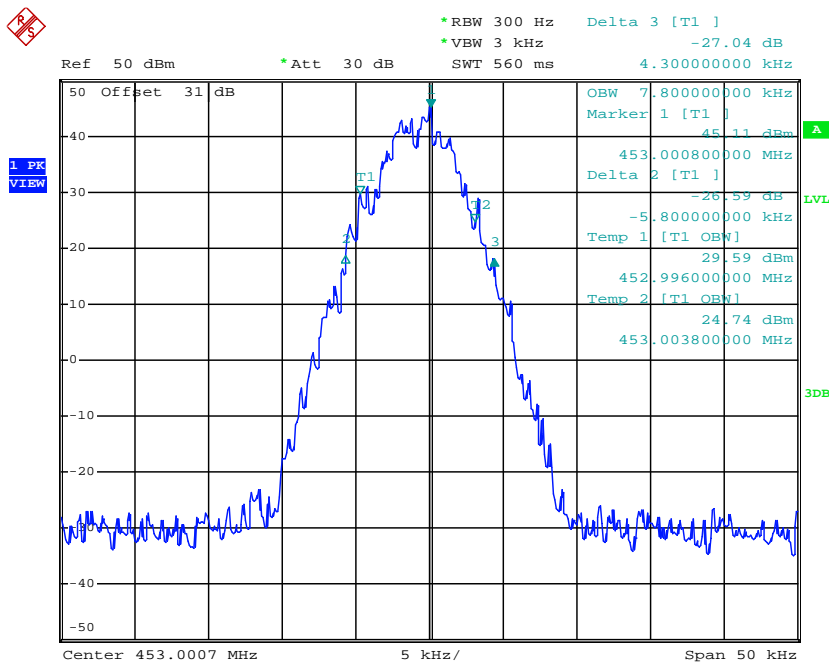

Date: 30.JAN.2013 16:37:16

Modulation Type	Channel Separation	Freq.(MHz)	99% Bandwidth (KHz)	26dB Bandwidth (KHz)	FCC Limit (KHz)	Results
4FSK	12.5 KHz	469.5000	7.70	9.40	11.25	Complicance

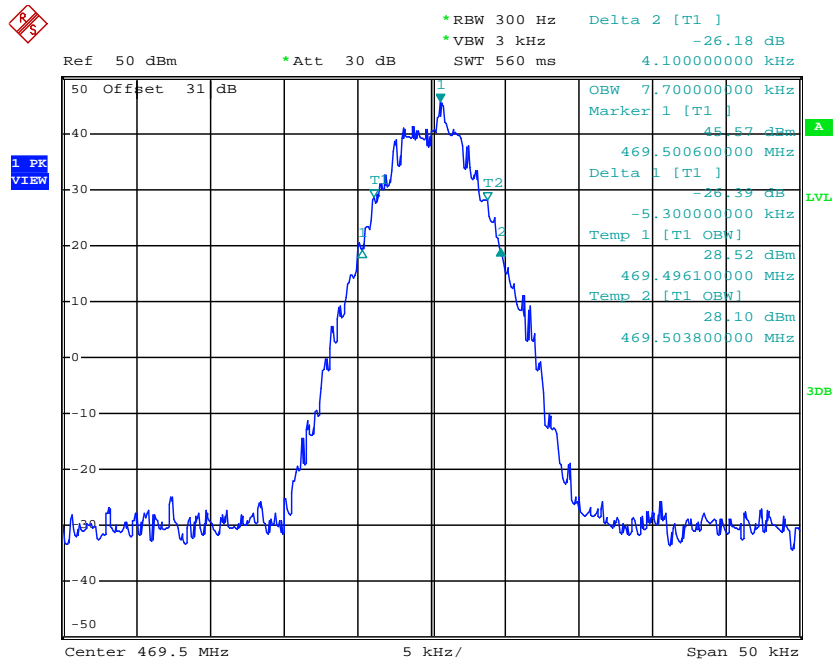

Date: 30.JAN.2013 16:30:46

4.2.2 Emission Mask

Modulation Type	Channel Sparation	Test Channel	Test Frequency	FCC Applicable Mask	RBW
FM	12.5KHz	Low	406.5000 MHz	D	300 Hz
		Low	418.0000 MHz	D	300 Hz
		Middle	435.5000 MHz	D	300 Hz
		High	453.0000 MHz	D	300 Hz
		High	469.5000 MHz	D	300 Hz
4FSK	12.5KHz	Low	406.5000 MHz	D	300 Hz
		Low	418.0000 MHz	D	300 Hz
		Middle	435.5000 MHz	D	300 Hz
		High	453.0000 MHz	D	300 Hz
		High	469.5000 MHz	D	300 Hz
Test Results		Compliance			

Plots of Emission Mask Measurement

Referred as the attached plot hereinafter

Note: The Blue curve represents unmodulated signal.
The Black curve represents modulated signal.

Modulation Type	Channel Separation	Freq.(MHz)	FCC Applicable Mask	RBW	Audio Freq. (KHz)	Results
FM	12.5 KHz	406.5000	D	300	2.5	Complicance

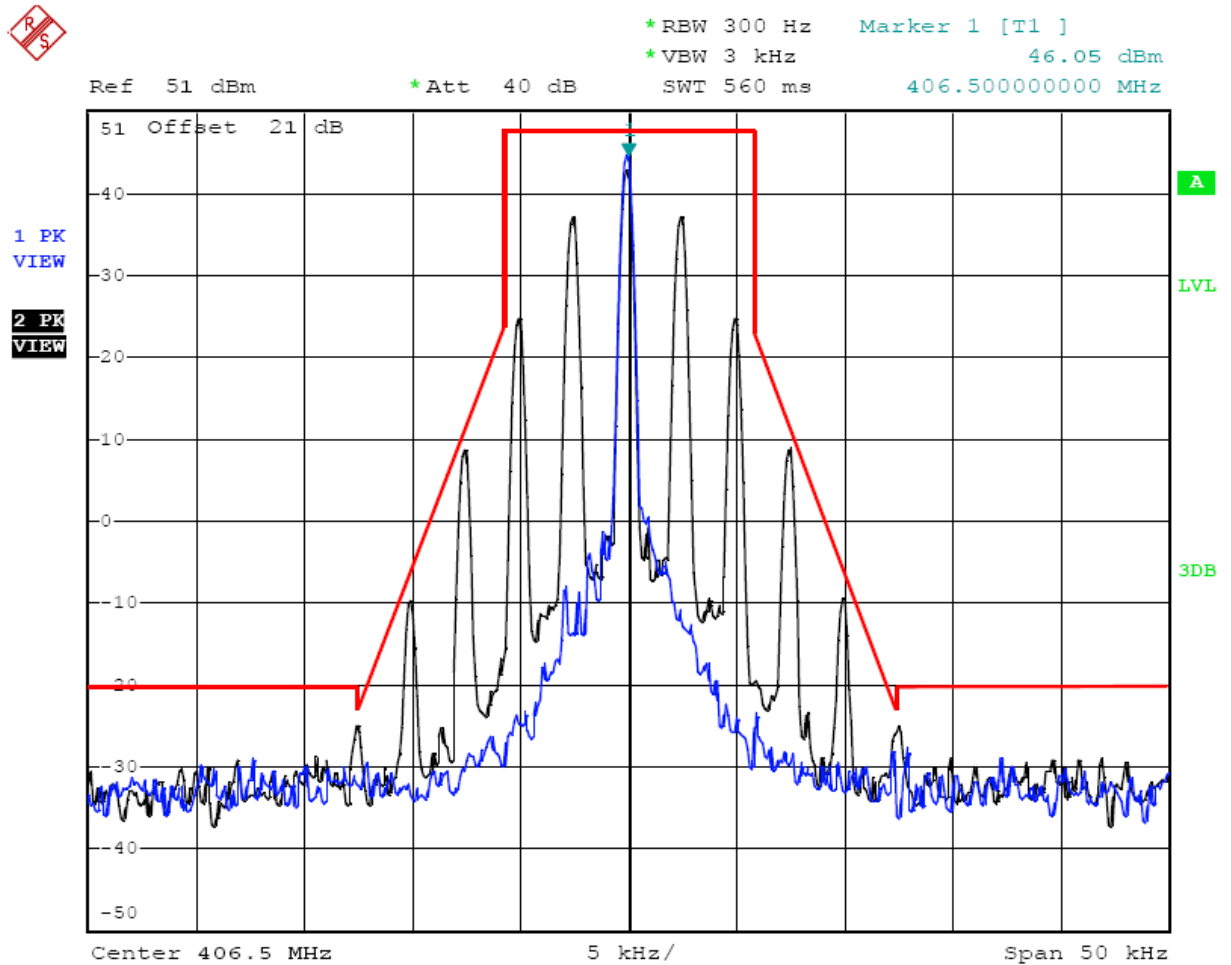

Date: 23.AUG.2013 10:00:00

12.5 kHz Channel Spacing, 406.5000 MHz, 2500 Hz Audio Modulation Only

Modulation Type	Channel Separation	Freq.(MHz)	FCC Applicable Mask	RBW	Audio Freq. (KHz)	Results
FM	12.5 KHz	418.0000	D	300Hz	2.5	Complicance

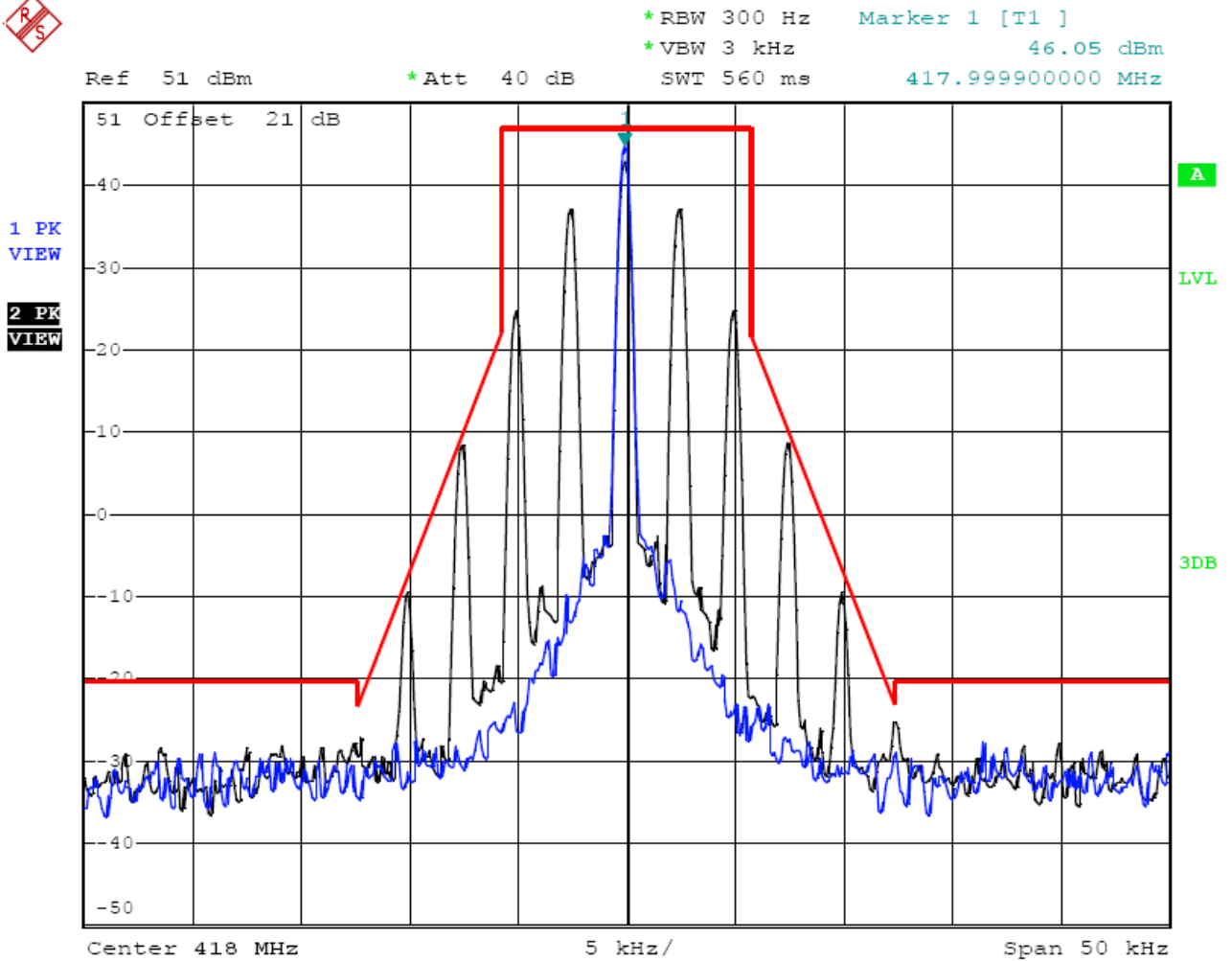

Date: 23.AUG.2013 10:05:23

12.5 kHz Channel Spacing, 418.0000 MHz, 2500 Hz Audio Modulation Only

Modulation Type	Channel Separation	Freq.(MHz)	FCC Applicable Mask	RBW	Audio Freq. (KHz)	Results
FM	12.5 KHz	435.5000	D	300Hz	2.5	Complicance

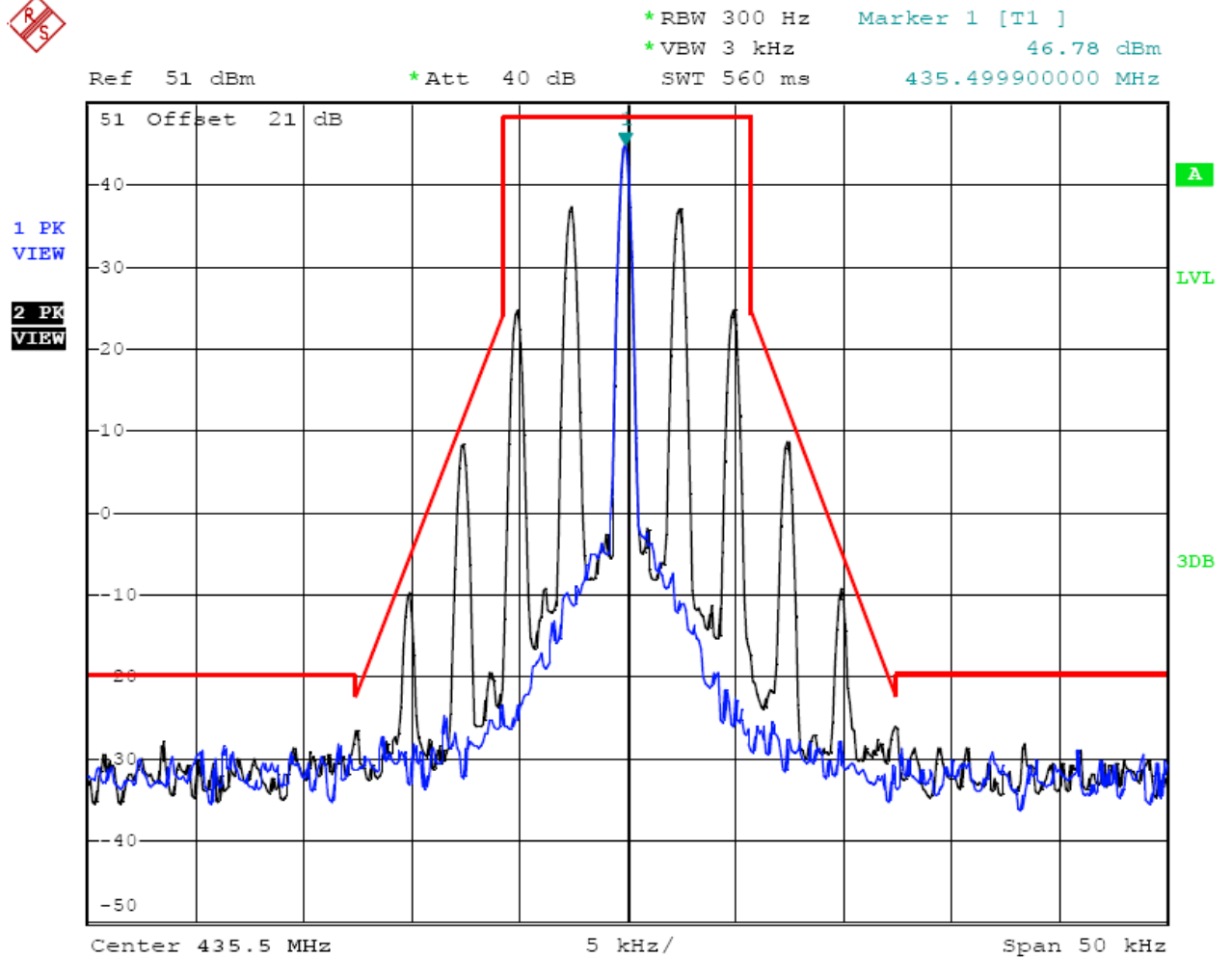

Date:23.AUG.2013 10:10:08

12.5 kHz Channel Spacing, 435.5000 MHz, 2500 Hz Audio Modulation Only

Modulation Type	Channel Separation	Freq.(MHz)	FCC Applicable Mask	RBW	Audio Freq. (KHz)	Results
FM	12.5 KHz	453.0000	D	300Hz	2.5	Complicance

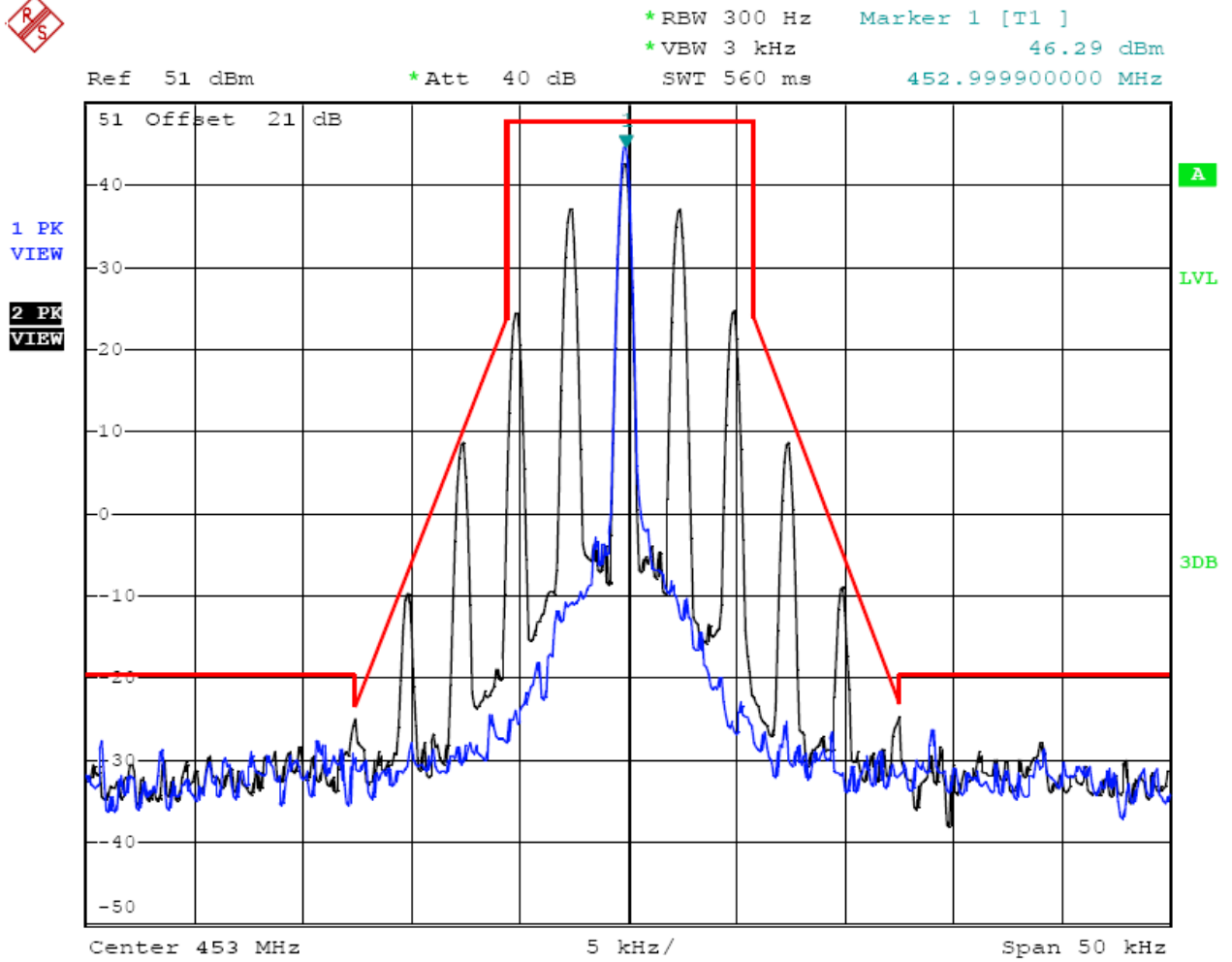

Date: 23.AUG.2013 10:15:00

12.5 kHz Channel Spacing, 453.0000 MHz, 2500 Hz Audio Modulation Only

Modulation Type	Channel Separation	Freq.(MHz)	FCC Applicable Mask	RBW	Audio Freq. (KHz)	Results
FM	12.5 KHz	469.5000	D	300Hz	2.5	Compliance



Ref 51 dBm *Att 40 dB *RBW 300 Hz Marker 1 [T1] 46.33 dBm
*VBW 3 kHz SWT 560 ms 469.499900000 MHz

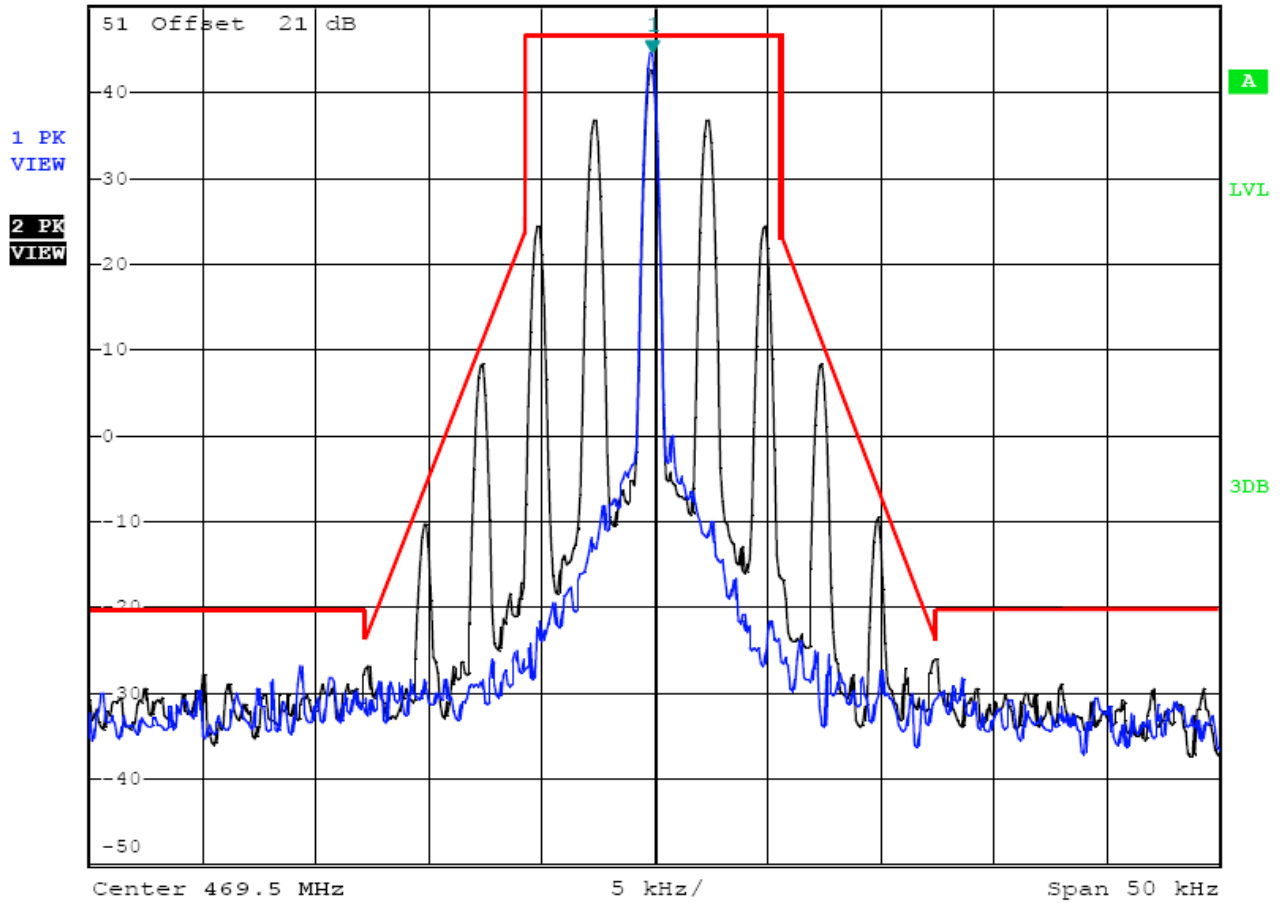

Date: 23.AUG.2013 10:20:04

12.5 kHz Channel Spacing, 469.5000 MHz, 2500 Hz Audio Modulation Only

Modulation Type	Channel Separation	Freq.(MHz)	FCC Applicable Mask	RBW	Audio Freq. (KHz)	Results
4FSK	12.5 KHz	453.0000	D	300Hz	/	Complicance

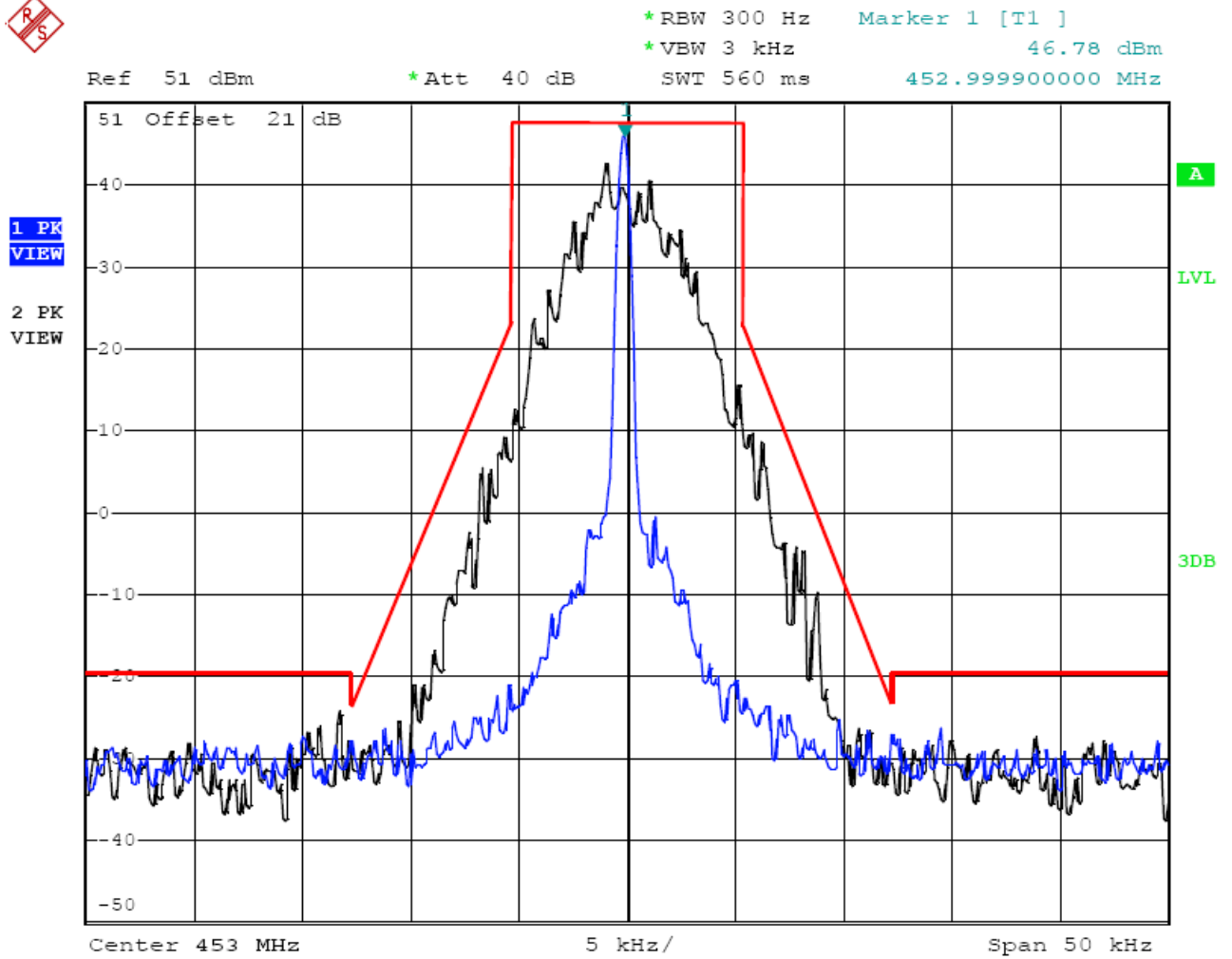

Date: 23.AUG.2013 10:30:18

12.5 kHz Channel Spacing, 453.0000 MHz, 4FSK Modulation Only

Modulation Type	Channel Separation	Freq.(MHz)	FCC Applicable Mask	RBW	Audio Freq. (KHz)	Results
4FSK	12.5 KHz	469.5000	D	300Hz	/	Complicance

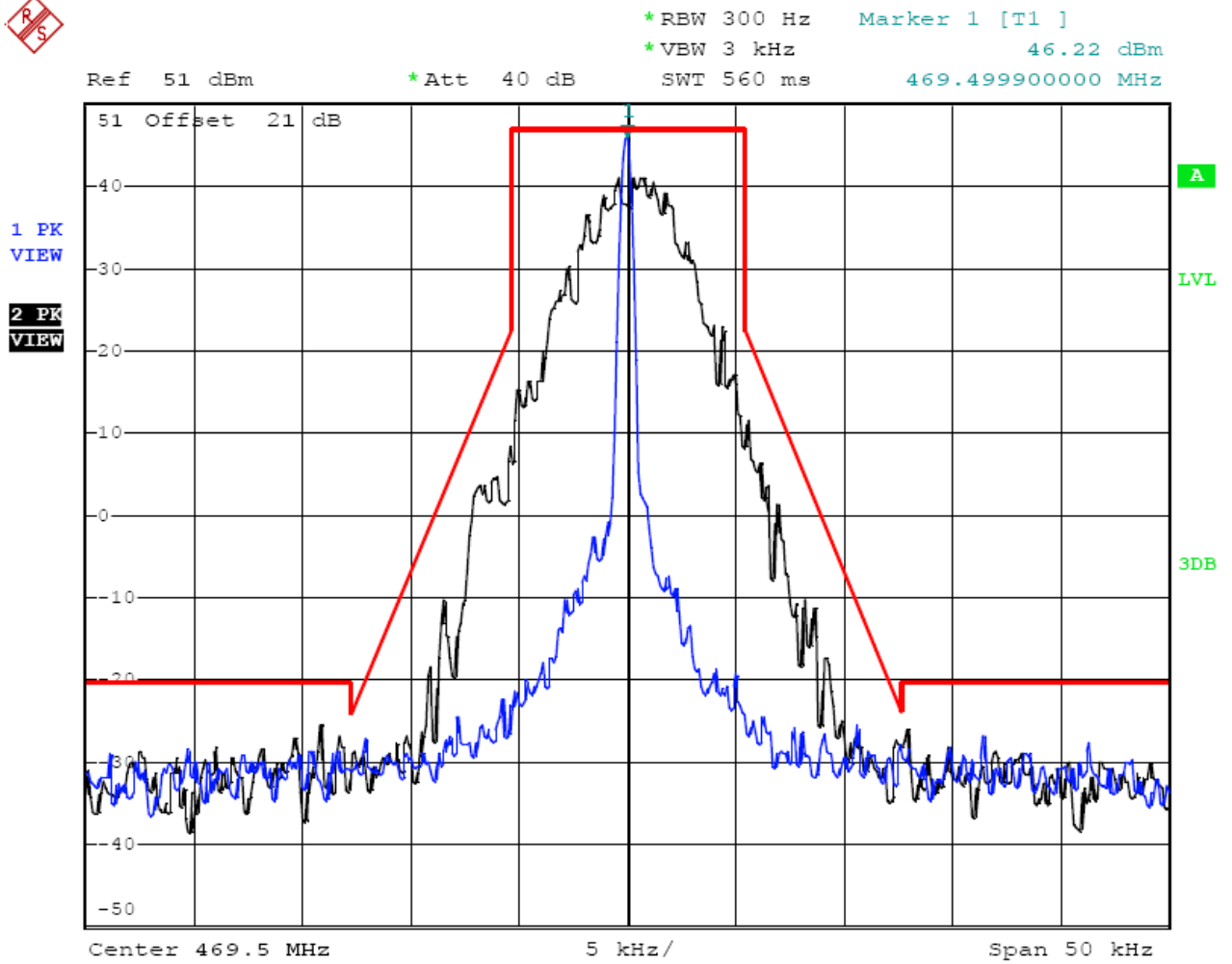

Date: 23.AUG.2013 10:32:52

12.5 kHz Channel Spacing, 469.5000 MHz, 4FSK Modulation Only

4.3. Transmitter Radiated Spurious Emission

TEST APPLICABLE

According to the TIA/EIA 603 test method, and according to Section 90.210, the power of each unwanted emission shall be less than Transmitted Power as specified below for transmitters designed to operate with 12.5 KHz channel bandwidth:

1. On any frequency removed from the center of the authorized bandwidth f_0 to 5.625 KHz removed from f_0 : Zero dB
2. On any frequency removed from the center of the authorized bandwidth by a displacement frequency (f_d in KHz) f_0 of more than 5.625 KHz but no more than 12.5 KHz: At least 7.27dB
3. On any frequency removed from the center of the authorized bandwidth by a displacement frequency (f_d in KHz) f_0 of more than 12.5 KHz: At least $50 + 10 \log(P)$ dB or 70 dB, which ever is lesser attenuation.

For transmitters designed to transmit with 25 KHz channel separation and equipped with an audio low-pass filter, the power of any emission must be attenuated below the unmodulated carrier power (P) as following:

1. On any frequency removed from the assigned frequency by more than 50 percent, but no more than 100 percent of the authorized bandwidth: At least 25 dB.
2. On any frequency removed from the assigned frequency by more than 100 percent, but no more than 250 percent of the authorized bandwidth: At least 35 dB.
3. On any frequency removed from the assigned frequency by more than 250 percent of the authorized bandwidth: At least $43 + 10 \log(P)$ dB.

TEST CONFIGURATION

Below 1GHz

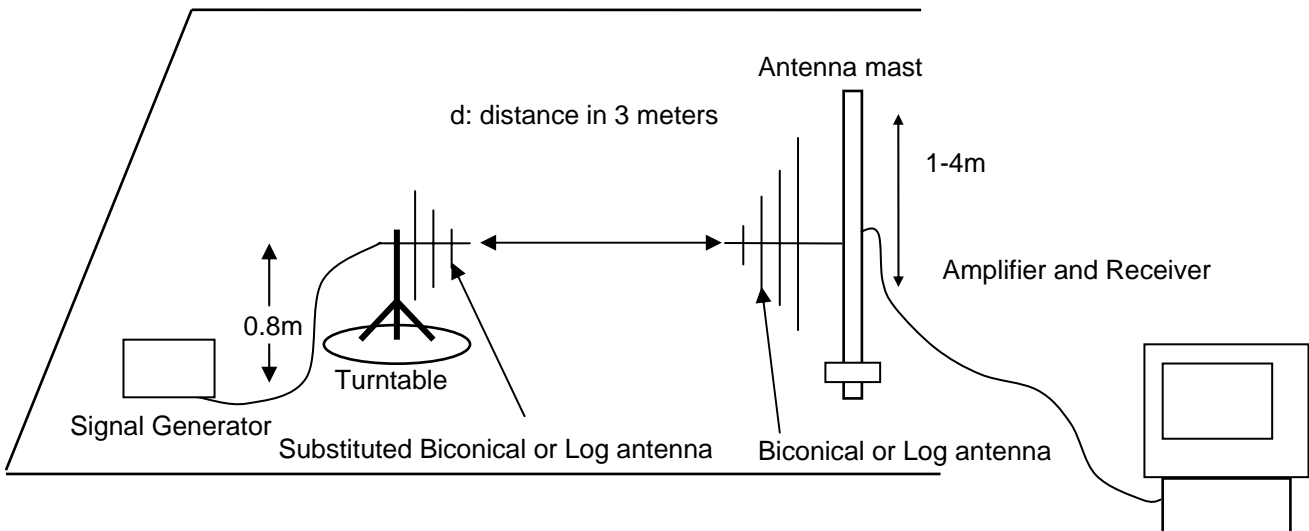
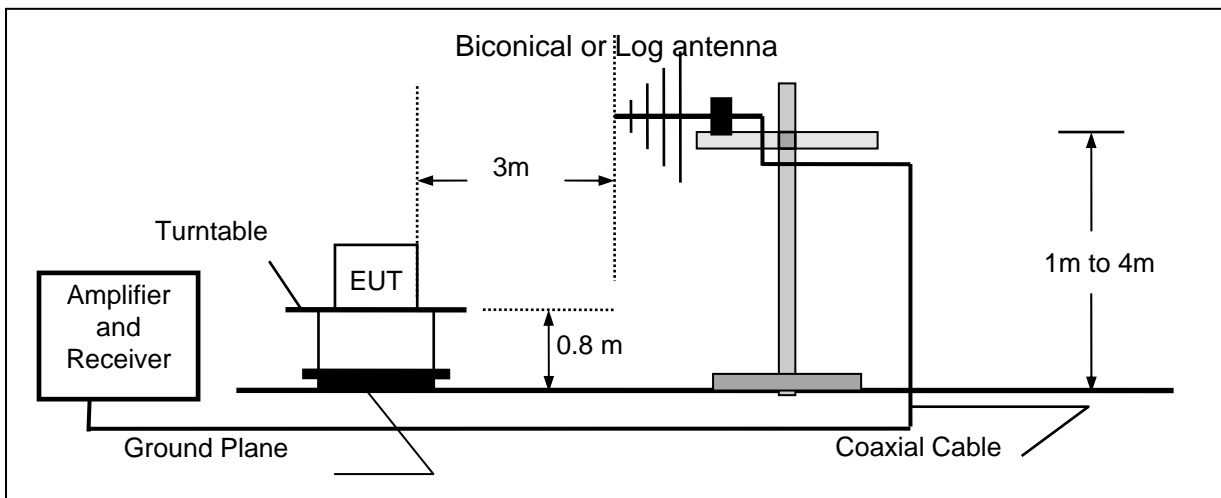

Above 1GHz

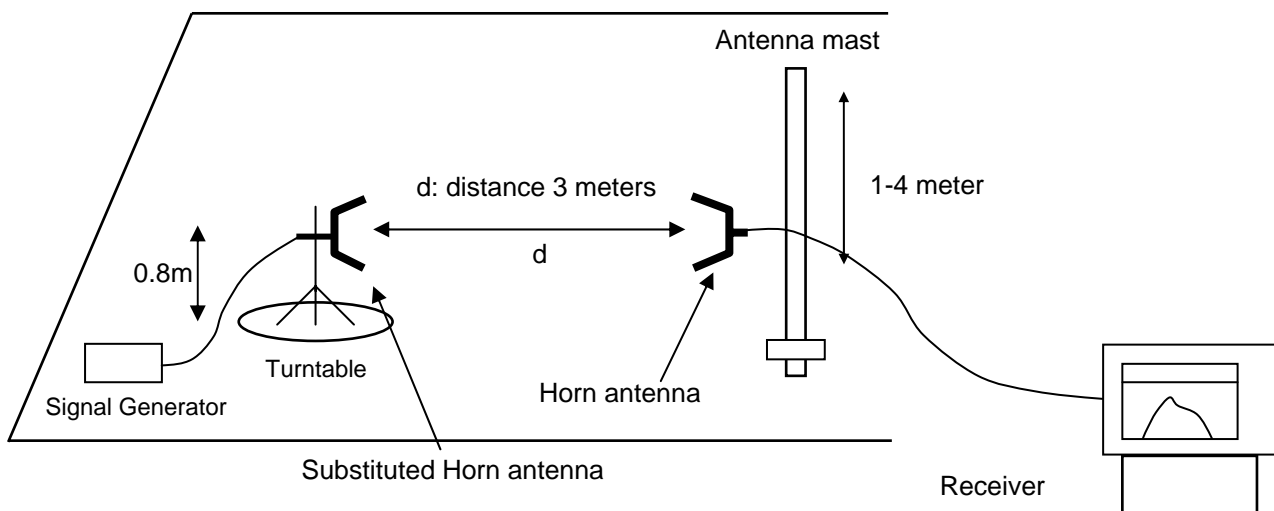
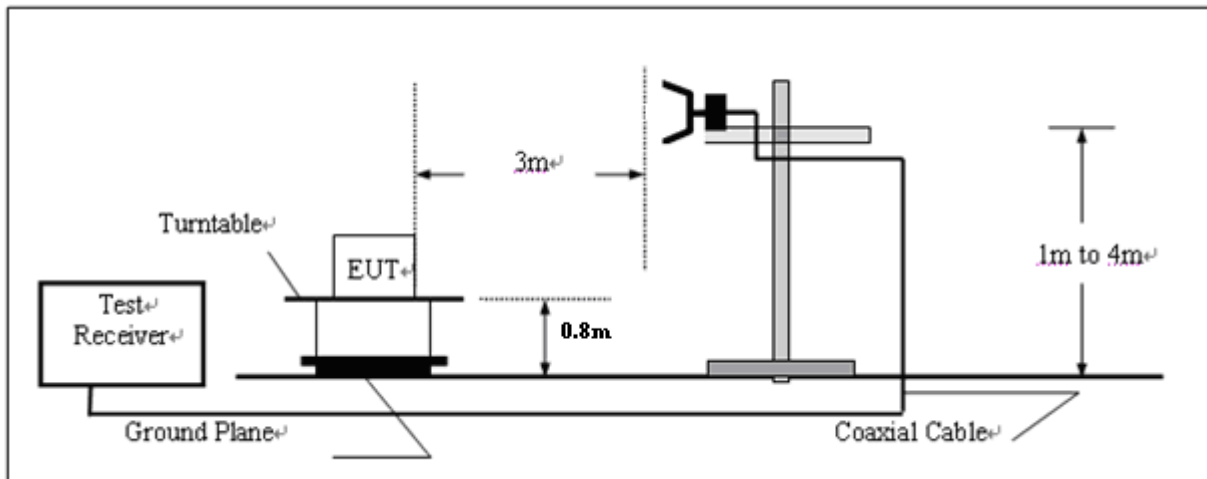
**TEST PROCEDURE**

1. Set the EMI Receiver (for measuring E-Field) and Receiver (for measuring EIRP) as follows:
Center Frequency: equal to the signal source
Resolution BW: 100 KHz
Video BW: VBW > RBW
Detector Mode: positive
Average: off
Span: 3 x the signal bandwidth
2. Load an appropriate correction factors file in EMI Receiver for correcting the field strength reading level
Total Correction Factor recorded in the EMI Receiver = Cable Loss + Antenna Factor + Amplifier Gain
 $E \text{ (dBuV/m)} = \text{Reading (dBuV)} + \text{Total Correction Factor (dB)}$
3. The transmitter under test was placed at the specified height on a non-conducting turntable (80 cm height)
4. Substitute the EUT by a signal generator and one of the following transmitting antenna (substitution antenna):
DIPOLE antenna for frequency from 30-1000 MHz or
HORN antenna for frequency above 1 GHz}.
5. Mount the transmitting antenna at 1.0 meter high from the ground plane.
6. Use one of the following antenna as a receiving antenna:
DIPOLE antenna for frequency from 30-1000 MHz or
HORN antenna for frequency above 1 GHz}.
7. If the DIPOLE antenna is used, tune it's elements to the frequency as specified in the calibration manual.
8. Adjust both transmitting and receiving antenna in a VERTICAL polarization.
9. Tune the EMI Receivers to the test frequency.
10. Lower or raise the test antenna from 1 to 4 meters until the maximum signal level was detected.
11. The transmitter was rotated through 360o about a vertical axis until a higher maximum signal was received.
12. Lower or raise the test antenna from 1 to 4 meters until the maximum signal level was detected.

13. Adjust input signal to the substitution antenna until an equal or a known related level to that detected from the transmitter was obtained in the test receiver.
14. Record the power level read from the Average Power Meter and calculate the ERP/EIRP as follows:

$$P = P_1 - L_1 = (P_2 + L_2) - L_1 = P_3 + A + L_2 - L_1$$

$$\text{EIRP} = P + G_1 = P_3 + L_2 - L_1 + A + G_1$$

$$\text{ERP} = \text{EIRP} - 2.15 \text{ dB}$$
 Total Correction factor in EMI Receiver = $L_2 - L_1 + G_1$
- Where:
 P: Actual RF Power fed into the substitution antenna port after corrected.
 P₁: Power output from the signal generator
 P₂: Power measured at attenuator A input
 P₃: Power reading on the Average Power Meter
 EIRP: EIRP after correction
 ERP: ERP after correction
15. Adjust both transmitting and receiving antenna in a Horizontal polarization, then repeat step (11) to (14).
16. Repeat step (4) to (16) for different test frequency
17. Repeat steps (3) to (12) with the substitution antenna oriented in horizontal polarization.
18. Actual gain of the EUT's antenna is the difference of the measured EIRP and measured RF power at the RF port. Correct the antenna gain if necessary.

TEST RESULTS

The Transmitter Radiated Spurious Emission was performed to the Rated high power (50Watt) and Rated low power (15Watt) the datum that reported below is the worst case (Rated high power) of the two rated power conditions.

Modulation Type: FM

FCC Part 22.359, 74.462, 80.211 and 90.210 and RSS Gen, RSS 119 Issue 11 (12.5 kHz bandwidth only): On any frequency removed from the center of the authorized bandwidth by a displacement frequency (f d in kHz) of more than 12.5 kHz at least:

Low: $50 + 10 \log (P_{\text{watts}}) = 50 + 10 \log (41.50) = 66.18 \text{ dB}$

High: $50 + 10 \log (P_{\text{watts}}) = 50 + 10 \log (57.68) = 67.61 \text{ dB}$

Note: In general, the worse case attenuation requirement shown above was applied.

Calculation: Limit (dBm) = $\text{EL} - 50 - 10 \log_{10} (\text{TP})$

Notes: EL is the emission level of the Output Power expressed in dBm,

In this application, the EL is 47.61 dBm.

Limit (dBm) = $47.61 - 50 - 10 \log_{10} (57.68) = -20 \text{ dBm}$

Modulation Type: 4FSK

FCC Part 22.359, 74.462, 80.211 and 90.210 and RSS Gen, RSS 119 Issue 11 (12.5 kHz Bandwidth only):

On any frequency removed from the center of the authorized bandwidth by a displacement frequency (f d in kHz) of more than 12.5 kHz at least:

Low: $50 + 10 \log (P_{\text{watts}}) = 50 + 10 \log (41.40) = 66.17 \text{ dB}$

High: $50 + 10 \log (P_{\text{watts}}) = 50 + 10 \log (57.15) = 67.57 \text{ dB}$

Note: In general, the worse case attenuation requirement shown above was applied.

Calculation: Limit (dBm) = $\text{EL} - 50 - 10 \log_{10} (\text{TP})$

Notes: EL is the emission level of the Output Power expressed in dBm,

In this application, the EL is 47.57 dBm.

Limit (dBm) = $47.57 - 50 - 10 \log_{10} (57.15) = -20 \text{ dBm}$

Note: 1. In general, the worse case attenuation requirement shown above was applied.

2. The measurement frequency range from 30 MHz to 6 GHz.

3. *** means that the emission level is too low to be measured or at least 20 dB down than the limit.

4.4. Spurious Emission on Antenna Port

TEST APPLICABLE

The same as Section 4.3

TEST PROCEDURE

The RF output of the EUT was connected to a spectrum analyzer through appropriate attenuation. The resolution bandwidth of the spectrum analyzer was set to 100 kHz. Sufficient scans were taken to show any out of band emission up to 10th. Harmonic for the lower and the highest frequency range. Set RBW 100 kHz, VBW 300 kHz in the frequency band 30MHz to 1GHz, while set RBW=1MHz. VBW=3MHz from the 1GHz to 10th Harmonic.

The audio input was set to 0 to get the unmodulated carrier, the resulting picture is print out for each channel separation.

TEST CONFIGURATION

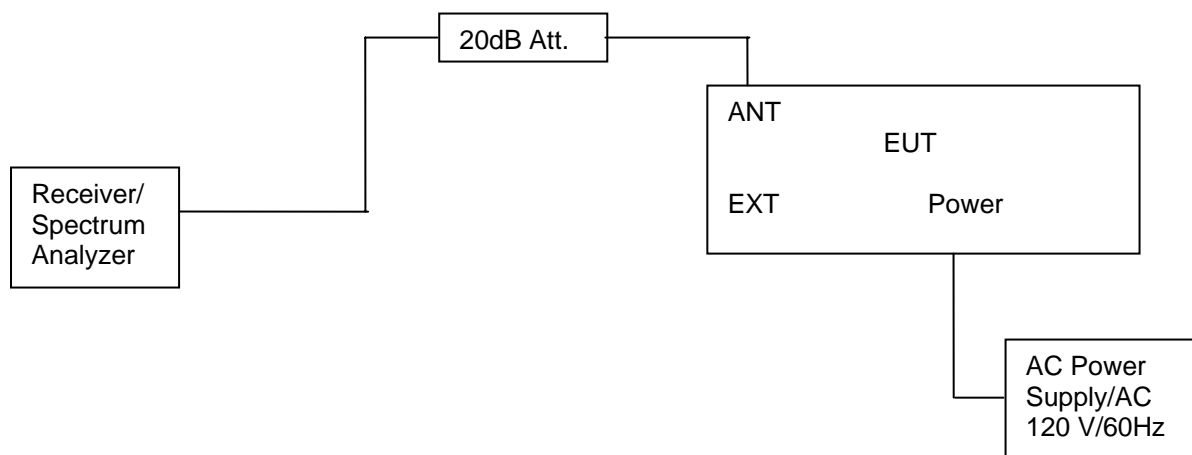

TEST RESULTS

Modulation Type: FM

FCC Part 22.359, 74.462, 80.211 and 90.210 and RSS Gen, RSS 119 Issue 11 (12.5 kHz bandwidth only): On any frequency removed from the center of the authorized bandwidth by a displacement frequency (f d in kHz) of more than 12.5 kHz at least:

Low: $50 + 10 \log (P_{\text{watts}}) = 50 + 10 \log (41.50) = 66.18 \text{ dB}$

High: $50 + 10 \log (P_{\text{watts}}) = 50 + 10 \log (57.68) = 67.61 \text{ dB}$

Note: In general, the worse case attenuation requirement shown above was applied.

Calculation: Limit (dBm) = EL - 50 - 10log₁₀ (TP)

Notes: EL is the emission level of the Output Power expressed in dBm,
In this application, the EL is 47.61 dBm.

Limit (dBm) = 47.61 - 50 - 10log₁₀ (57.68) = -20 dBm

Modulation Type: 4FSK

FCC Part 22.359, 74.462, 80.211 and 90.210 and RSS Gen, RSS 119 Issue 11 (12.5 kHz Bandwidth only):

On any frequency removed from the center of the authorized bandwidth by a displacement frequency (f d in kHz) of more than 12.5 kHz at least:

Low: $50 + 10 \log (P_{\text{watts}}) = 50 + 10 \log (41.40) = 66.17 \text{ dB}$

High: $50 + 10 \log (P_{\text{watts}}) = 50 + 10 \log (57.15) = 67.57 \text{ dB}$

Note: In general, the worse case attenuation requirement shown above was applied.

Calculation: Limit (dBm) = EL - 50 - 10log₁₀ (TP)

Notes: EL is the emission level of the Output Power expressed in dBm,
In this application, the EL is 47.57 dBm.

Limit (dBm) = 47.57 - 50 - 10log₁₀ (57.15) = -20 dBm

Note: 1. In general, the worse case attenuation requirement shown above was applied.

2. The measurement frequency range from 30 MHz to 6 GHz.
3. *** means that the emission level is too low to be measured or at least 20 dB down than the limit.

For Rated High Power (50Watt)

Modulation Type	Channel Separation	Test Channel	Test Frequency (MHz)	Maximum Conducted Spurious Emissions Below 1GHz		Maximum Conducted Spurious Emissions Above 1GHz	
				Frequency (MHz)	Datum (dBm)	Frequency (MHz)	Datum (dBm)
FM	12.5KHz	Low	406.5000	813.00	-48.95	1220.00	-57.12
		Low	418.0000	836.00	-40.72	1250.00	-54.69
		Middle	435.5000	871.00	-41.28	1300.00	-55.06
		High	453.0000	906.00	-44.60	1360.00	-54.88
		High	469.5000	939.00	-42.41	1400.00	-51.57
4FSK	12.5KHz	Low	406.5000	813.00	-42.43	3170.00	-46.12
		Low	418.0000	836.00	-40.72	1250.00	-54.69
		Middle	435.5000	871.00	-37.79	3270.00	-46.20
		High	453.0000	906.00	-42.89	3280.00	-46.03
		High	469.5000	926.00	-49.60	3110.00	-46.36
Limit		-20dBm for 12.5KHz Channel Separation					
Test Results		Compliance					

For Rated Low Power (15Watt)

Modulation Type	Channel Separation	Test Channel	Test Frequency (MHz)	Maximum Conducted Spurious Emissions Below 1GHz		Maximum Conducted Spurious Emissions Above 1GHz	
				Frequency (MHz)	Datum (dBm)	Frequency (MHz)	Datum (dBm)
FM	12.5KHz	Low	406.5000	605.00	-58.91	3250.00	-55.22
		Low	418.0000	836.00	-53.63	3140.00	-55.73
		Middle	435.5000	871.00	-47.76	3080.00	-55.98
		High	453.0000	906.00	-54.50	3210.00	-56.46
		High	469.5000	939.00	-53.71	3190.00	-55.71
4FSK	12.5KHz	Low	406.5000	813.00	-55.09	3190.00	-45.23
		Low	418.0000	836.00	-53.63	3140.00	-55.73
		Middle	435.5000	871.00	-46.12	3140.00	-45.09
		High	453.0000	906.00	-42.89	3280.00	-46.03
		High	469.5000	926.00	-56.82	3200.00	-44.89
Limit		-20dBm for 12.5KHz Channel Separation					
Test Results		Compliance					

Plots of Spurious Emission on Antenna Port Measurement**For Rated High Power (50Watt)**

Modulation Type	Channel Separation	Test Channel	Test Frequency (MHz)	Maximum Conducted Spurious Emissions Below 1GHz		Maximum Conducted Spurious Emissions Above 1GHz		FCC Limit
				Frequency (MHz)	Datum (dBm)	Frequency (MHz)	Datum (dBm)	
FM	12.5KHz	Low	406.5000	813.00	-48.95	1220.00	-57.12	-20dBm
Test Results				Compliance				

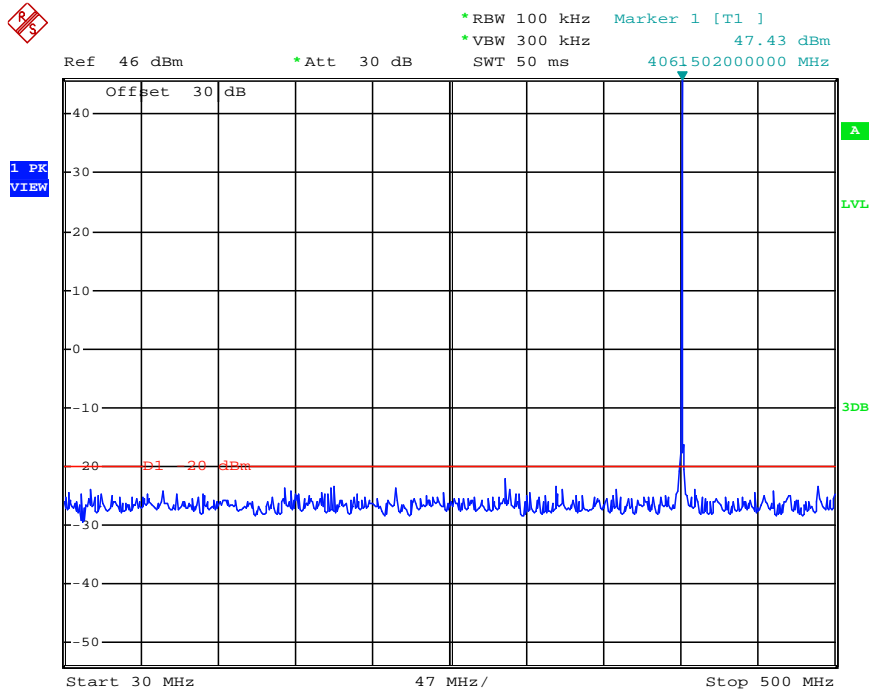

Date: 30.JAN.2013 15:40:49

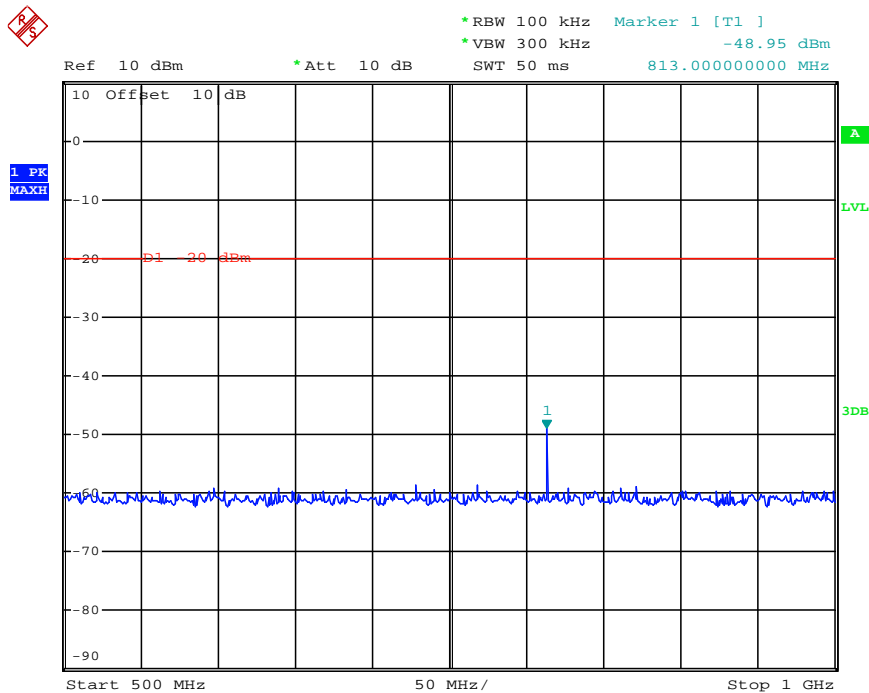

Date: 30.JAN.2013 15:44:09

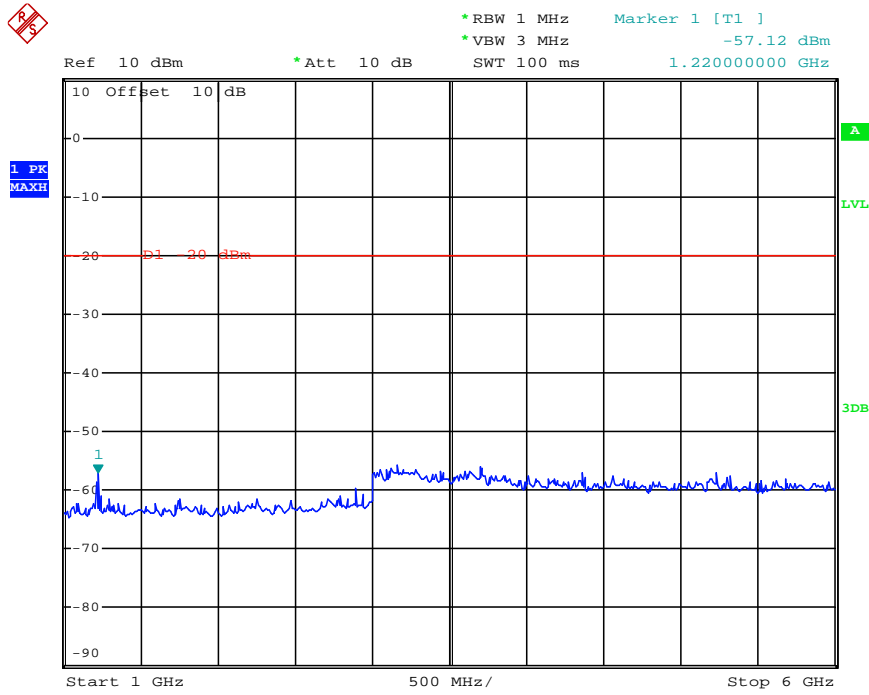

Date: 30.JAN.2013 15:44:32

Modulation Type	Channel Spation	Test Channel	Test Frequency (MHz)	Maximum Conducted Spurious Emissions Below 1GHz		Maximum Conducted Spurious Emissions Above 1GHz		FCC Limit
				Frequency (MHz)	Datum (dBm)	Frequency (MHz)	Datum (dBm)	
FM	12.5KHz	Low	418.0000	836.00	-40.72	1250.00	-54.69	-20dBm
Test Results				Compliance				

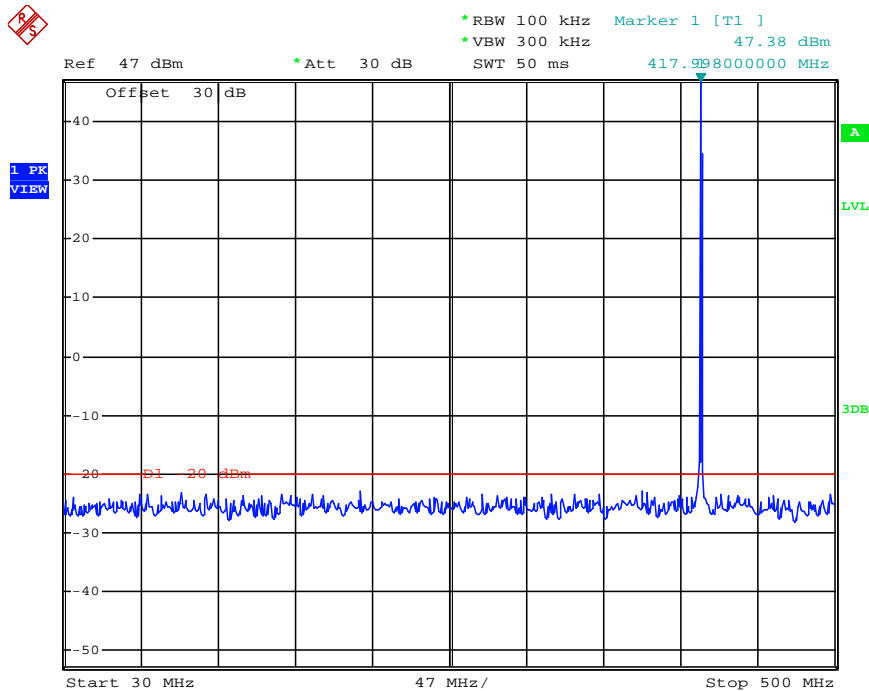

Date: 30.JAN.2013 15:50:48

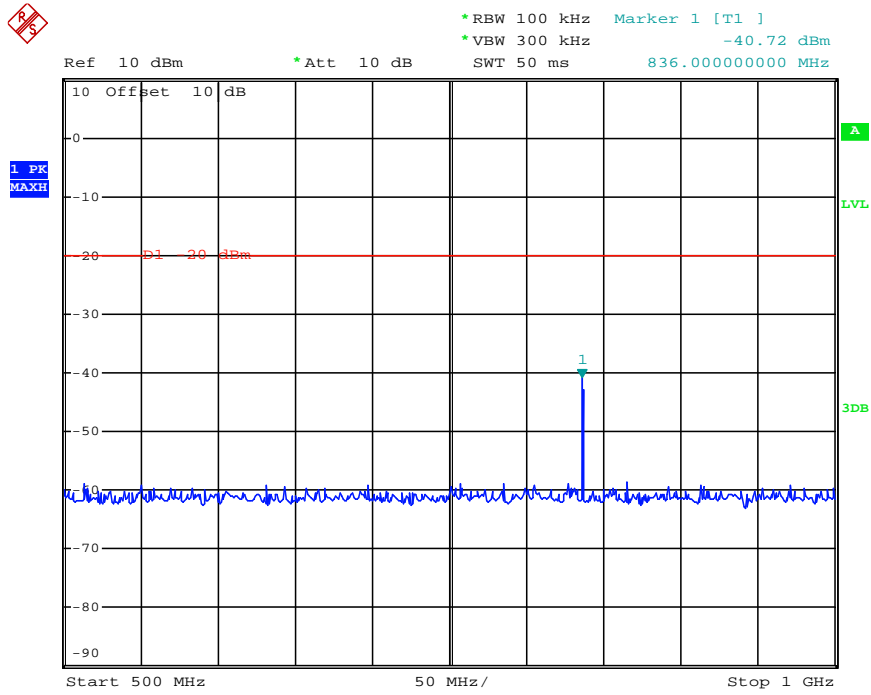

Date: 30.JAN.2013 15:52:26

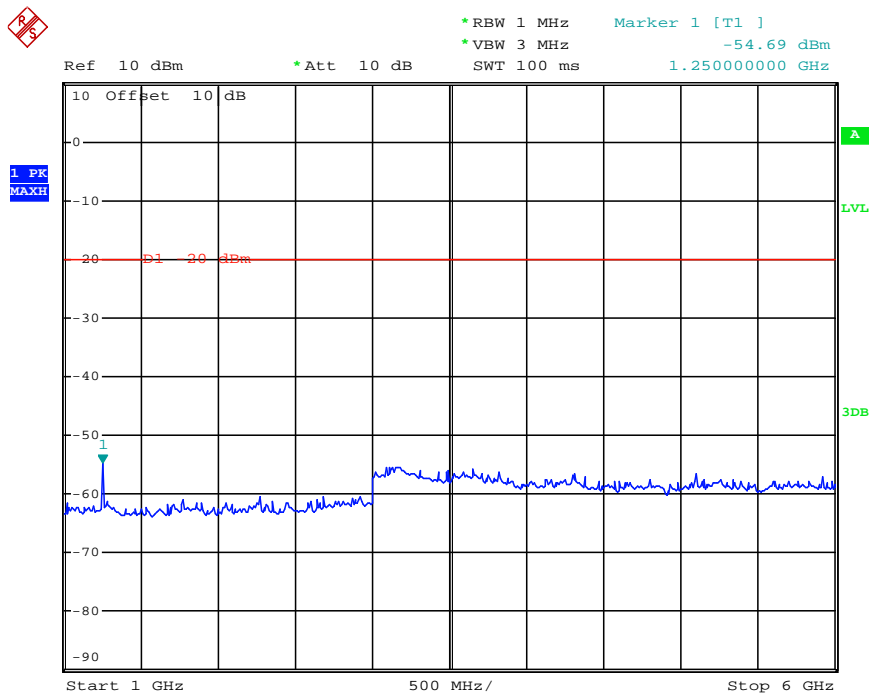

Date: 30.JAN.2013 15:53:59

Modulation Type	Channel Sparation	Test Channel	Test Frequency (MHz)	Maximum Conducted Spurious Emissions Below 1GHz		Maximum Conducted Spurious Emissions Above 1GHz		FCC Limit
				Frequency (MHz)	Datum (dBm)	Frequency (MHz)	Datum (dBm)	
FM	12.5KHz	Middle	435.5000	871.00	-41.28	1300.00	-55.06	-20dBm
Test Results				Compliance				

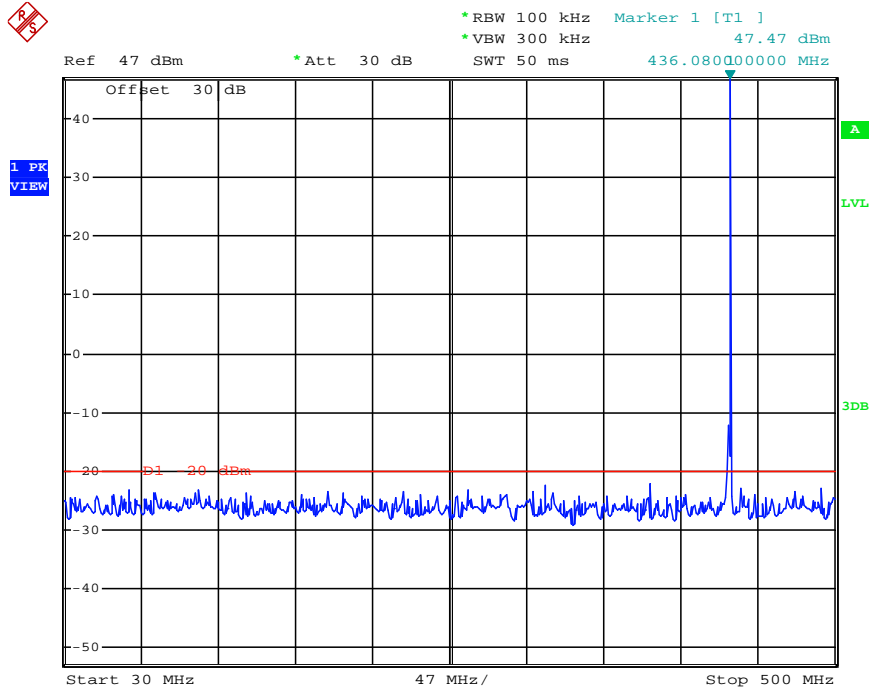

Date: 30.JAN.2013 16:07:08

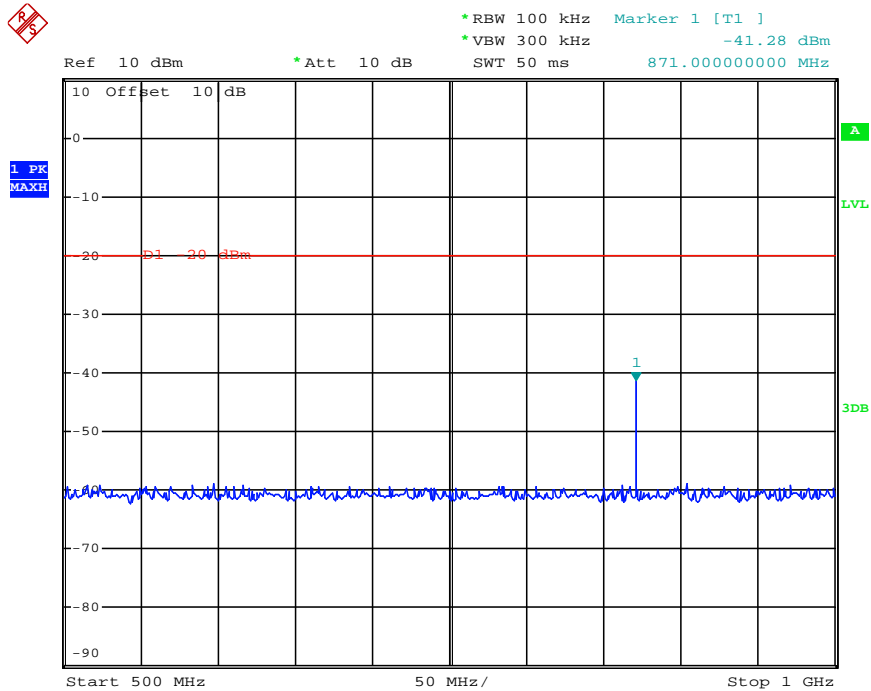

Date: 30.JAN.2013 16:01:46

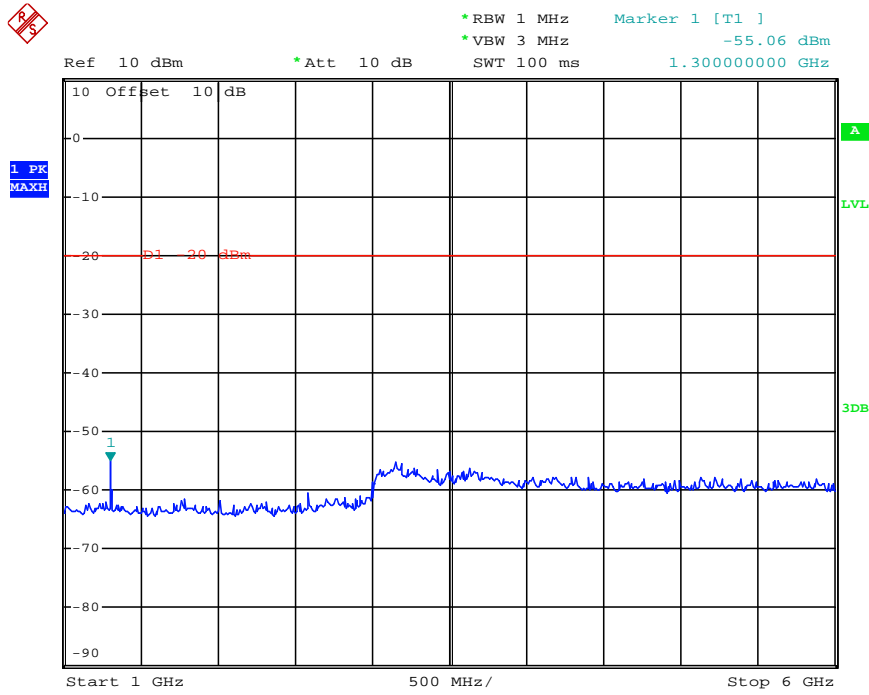

Date: 30.JAN.2013 16:02:07

Modulation Type	Channel Spation	Test Channel	Test Frequency (MHz)	Maximum Conducted Spurious Emissions Below 1GHz		Maximum Conducted Spurious Emissions Above 1GHz		FCC Limit
				Frequency (MHz)	Datum (dBm)	Frequency (MHz)	Datum (dBm)	
FM	12.5KHz	High	453.0000	906.00	-44.60	1360.00	-54.88	-20dBm
Test Results				Compliance				

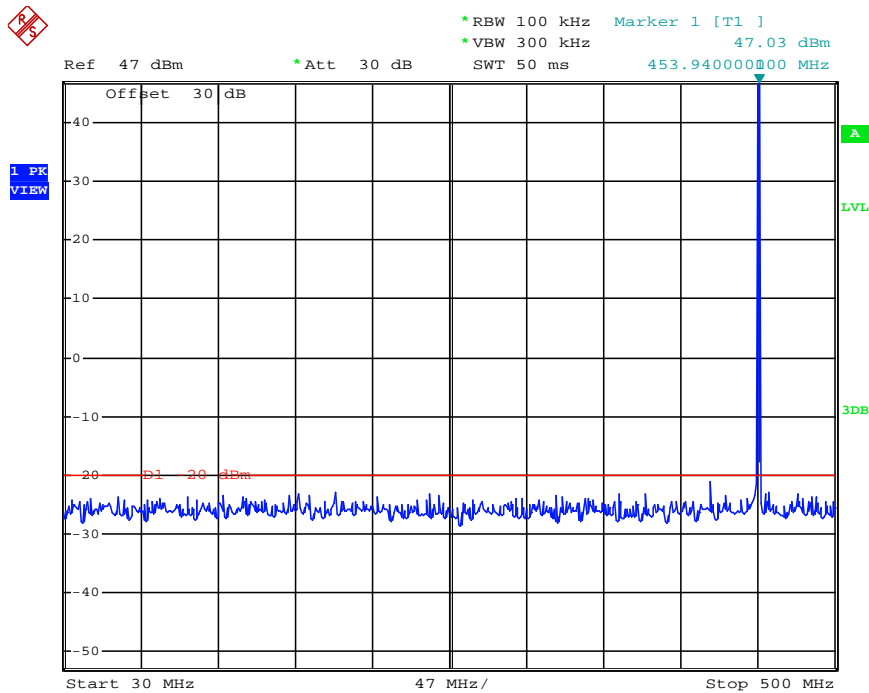

Date: 30.JAN.2013 16:11:25



*RBW 100 kHz Marker 1 [T1]
*VBW 300 kHz -44.60 dBm
SWT 50 ms 906.00000000 MHz

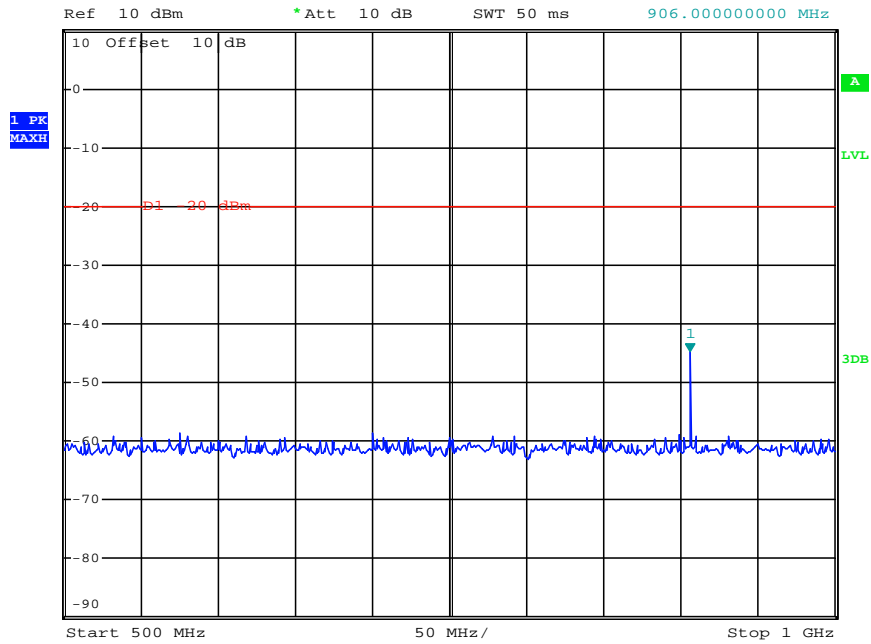

Date: 30.JAN.2013 16:12:53



*RBW 1 MHz Marker 1 [T1]
*VBW 3 MHz -54.88 dBm
SWT 100 ms 1.360000000 GHz

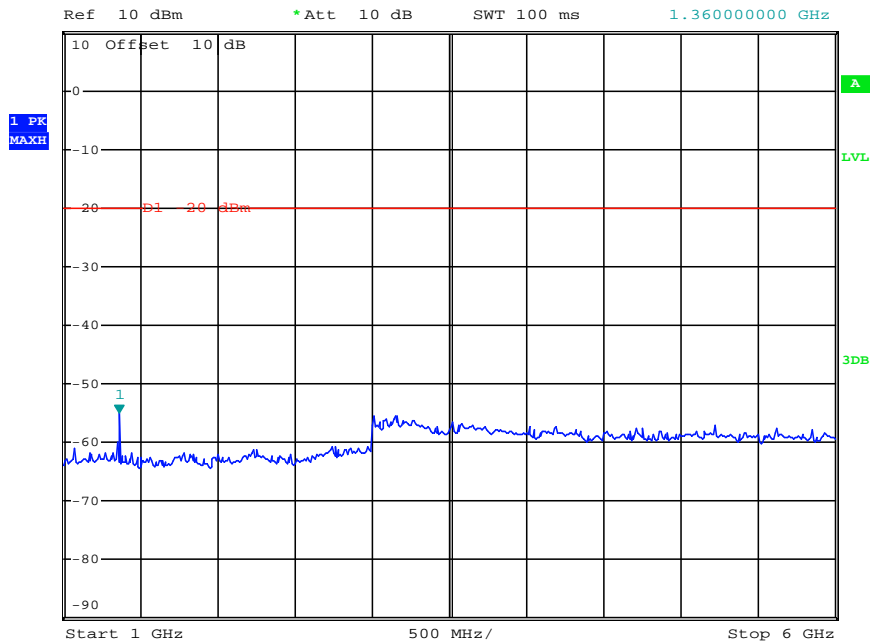

Date: 30.JAN.2013 16:14:08

Modulation Type	Channel Separation	Test Channel	Test Frequency (MHz)	Maximum Conducted Spurious Emissions Below 1GHz		Maximum Conducted Spurious Emissions Above 1GHz		FCC Limit
				Frequency (MHz)	Datum (dBm)	Frequency (MHz)	Datum (dBm)	
FM	12.5KHz	High	469.5000	939.00	-42.41	1400.00	-51.57	-20dBm
Test Results				Compliance				

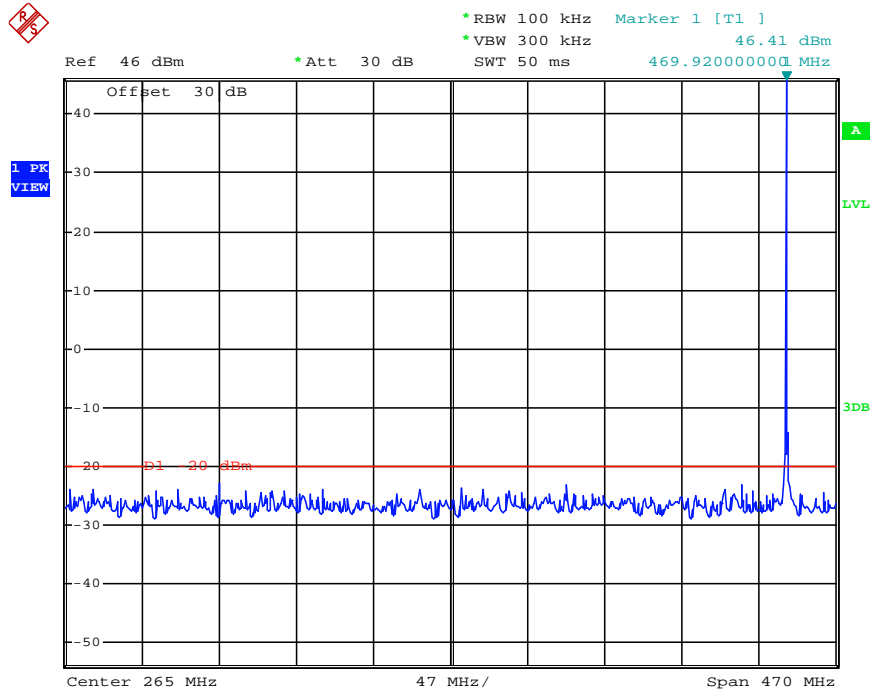

Date: 30.JAN.2013 16:18:43

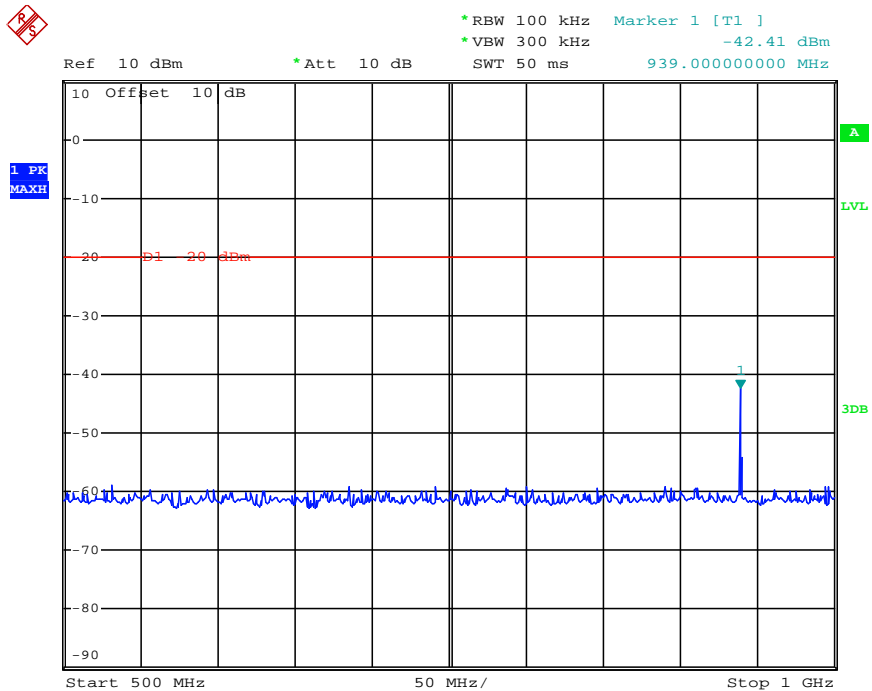

Date: 30.JAN.2013 16:20:41

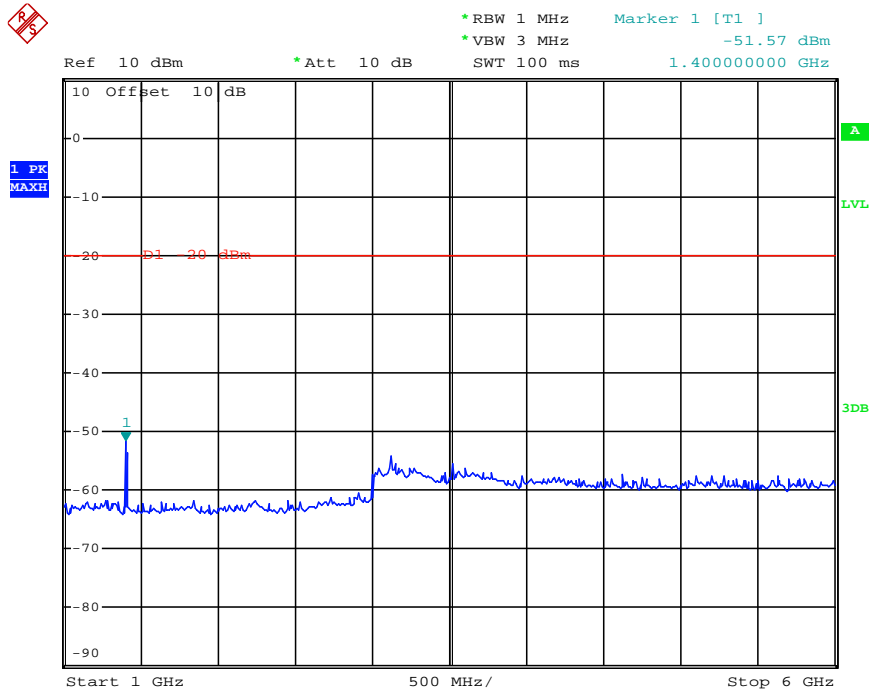

Date: 30.JAN.2013 16:21:54

Modulation Type	Channel SpARATION	Test Channel	Test Frequency (MHz)	Maximum Conducted Spurious Emissions Below 1GHz		Maximum Conducted Spurious Emissions Above 1GHz		FCC Limit
				Frequency (MHz)	Datum (dBm)	Frequency (MHz)	Datum (dBm)	
4FSK	12.5KHz	Low	406.5000	813.00	-42.43	3170.00	-46.12	-20dBm
Test Results				Compliance				

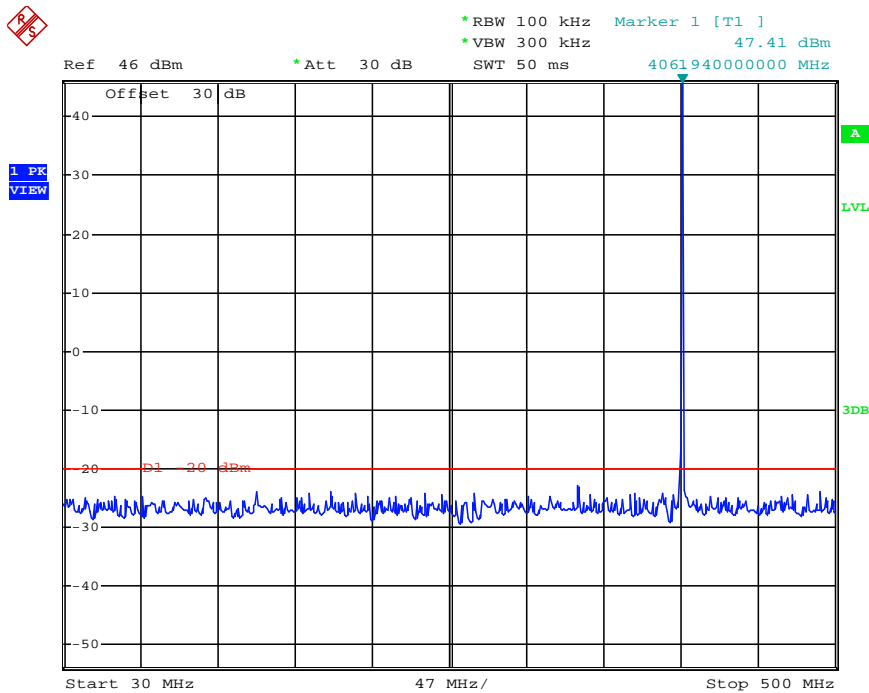

Date: 4.FEB.2013 17:22:12

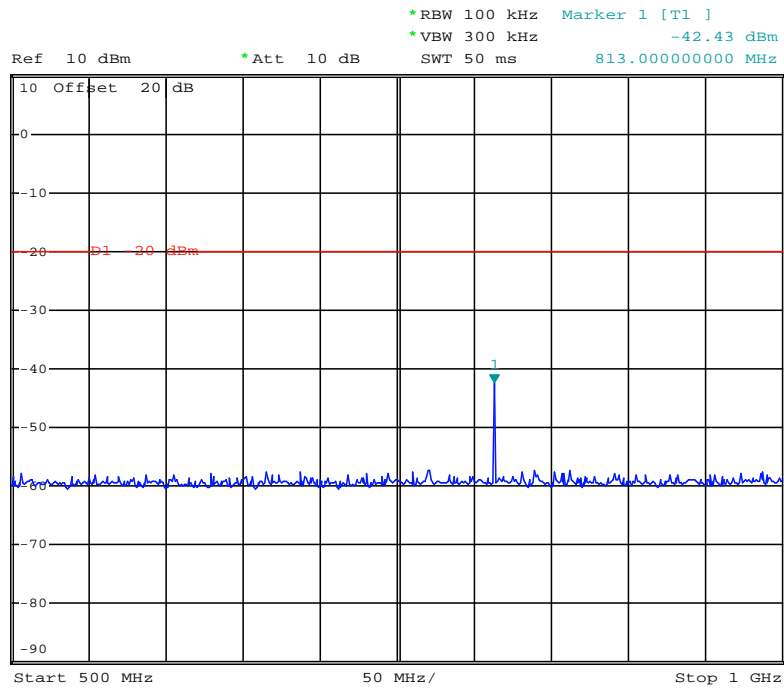

Date: 4.FEB.2013 17:27:00

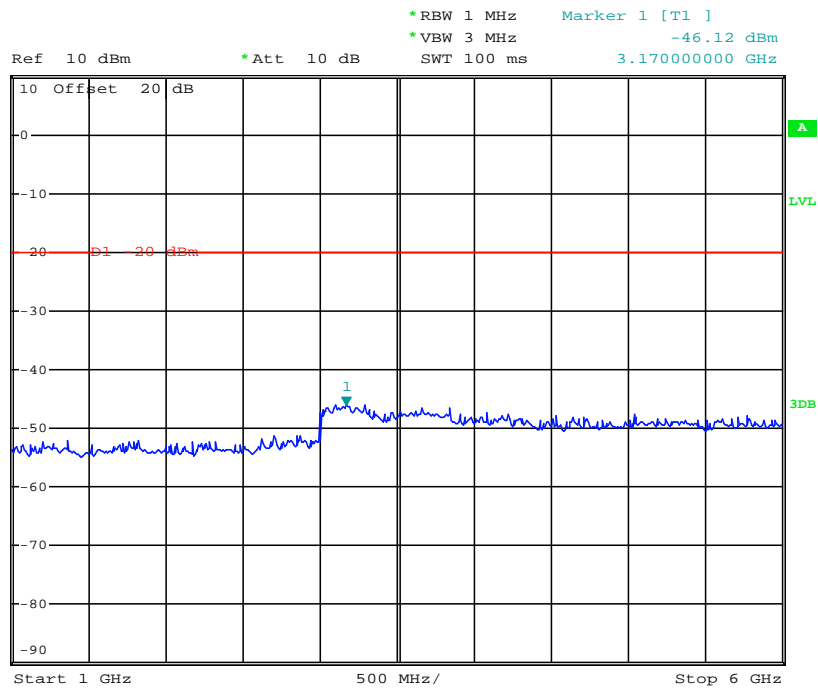

Date: 4.FEB.2013 17:27:40

Modulation Type	Channel Sparation	Test Channel	Test Frequency (MHz)	Maximum Conducted Spurious Emissions Below 1GHz		Maximum Conducted Spurious Emissions Above 1GHz		FCC Limit
				Frequency (MHz)	Datum (dBm)	Frequency (MHz)	Datum (dBm)	
4FSK	12.5KHz	Low	418.0000	836.00	-40.72	1250.00	-54.69	-20dBm
Test Results				Compliance				

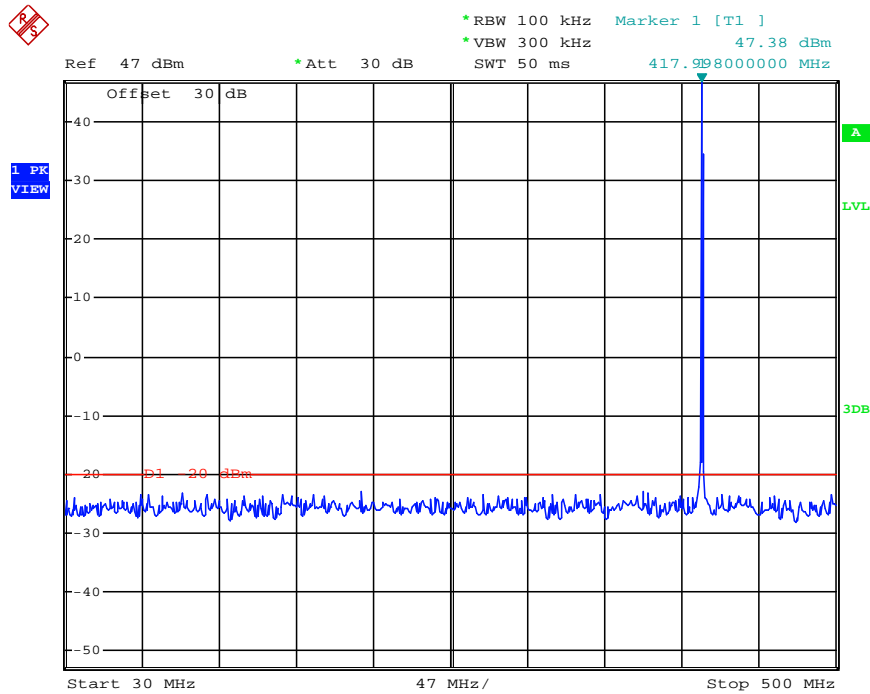

Date: 30.JAN.2013 15:50:48

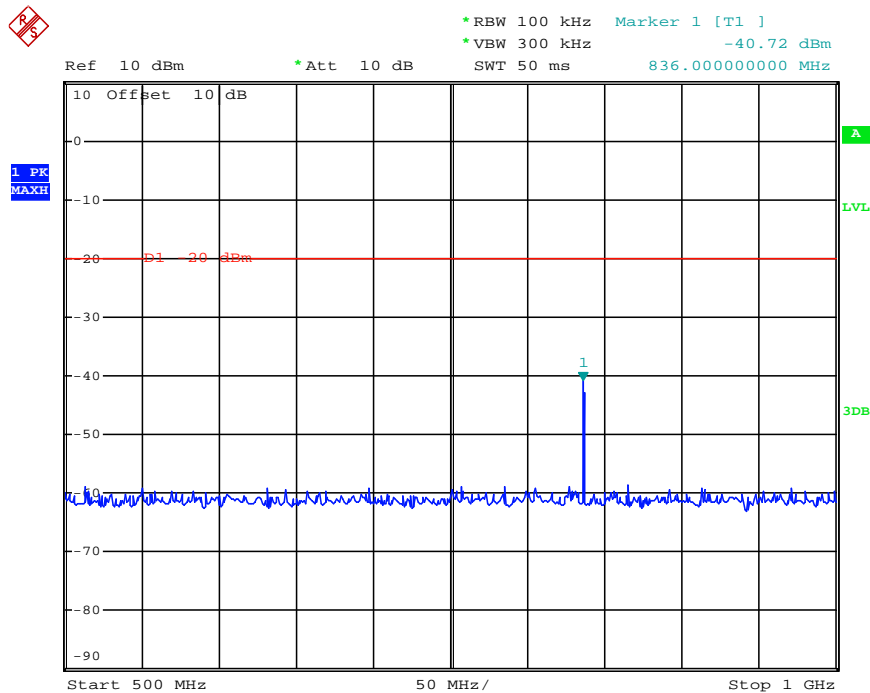

Date: 30.JAN.2013 15:52:26

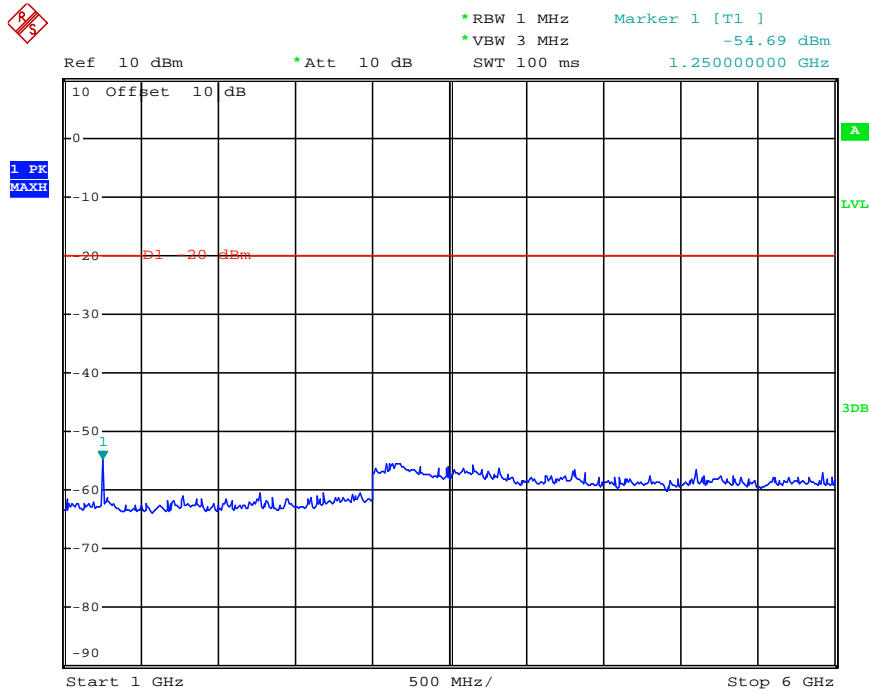

Date: 30.JAN.2013 15:53:59

Modulation Type	Channel Spation	Test Channel	Test Frequency (MHz)	Maximum Conducted Spurious Emissions Below 1GHz		Maximum Conducted Spurious Emissions Above 1GHz		FCC Limit
				Frequency (MHz)	Datum (dBm)	Frequency (MHz)	Datum (dBm)	
4FSK	12.5KHz	Middle	435.5000	871.00	-37.79	3270.00	-46.20	-20dBm
Test Results				Compliance				

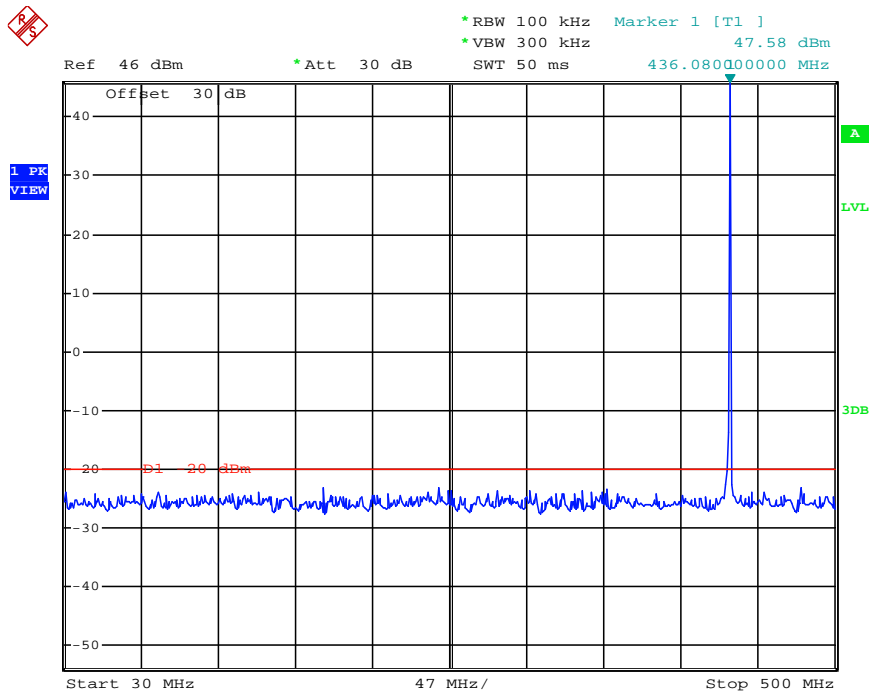

Date: 4.FEB.2013 17:37:16

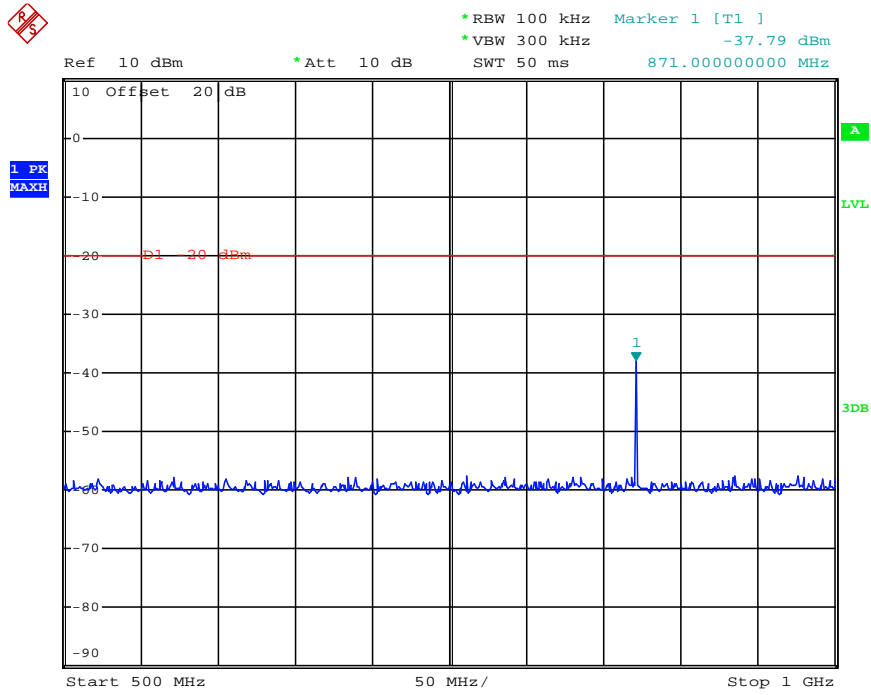

Date: 4.FEB.2013 17:33:16

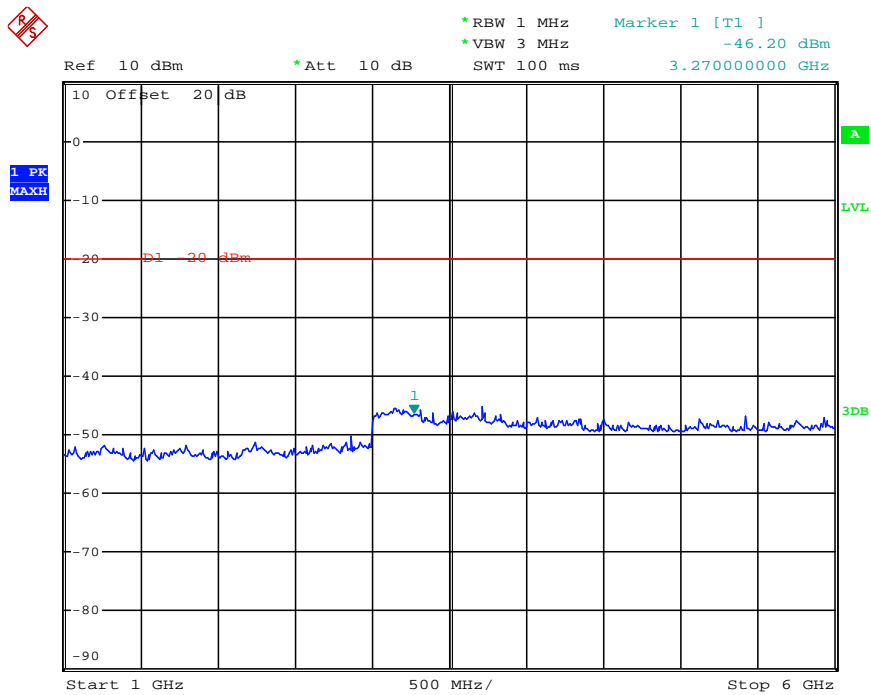

Date: 4.FEB.2013 17:31:56

Modulation Type	Channel Separation	Test Channel	Test Frequency (MHz)	Maximum Conducted Spurious Emissions Below 1GHz		Maximum Conducted Spurious Emissions Above 1GHz		FCC Limit
				Frequency (MHz)	Datum (dBm)	Frequency (MHz)	Datum (dBm)	
4FSK	12.5KHz	High	453.0000	906.00	-42.89	3280.00	-46.03	-20dBm
Test Results				Compliance				

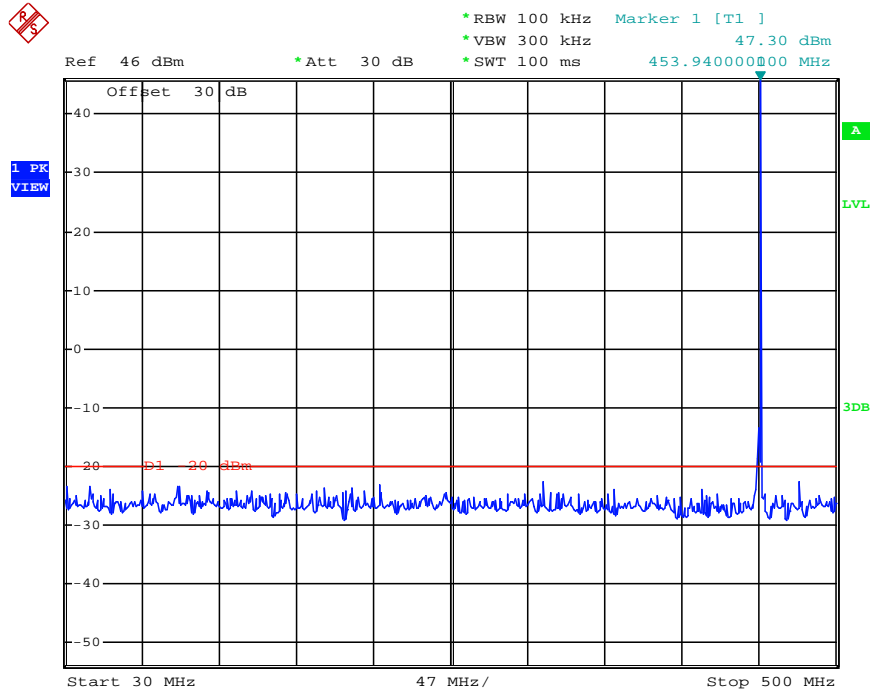

Date: 4.FEB.2013 16:15:50

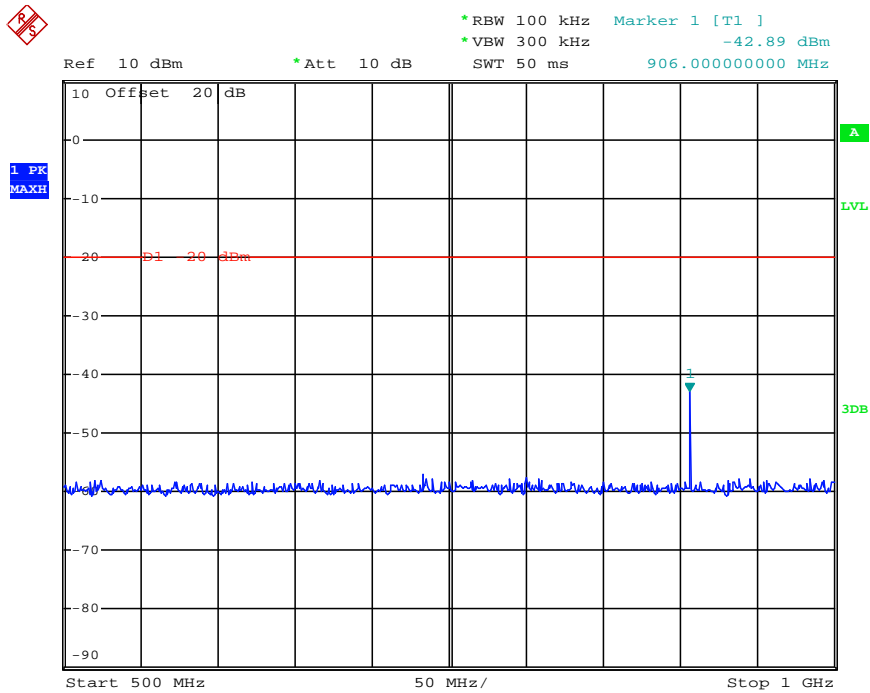

Date: 4.FEB.2013 16:53:34

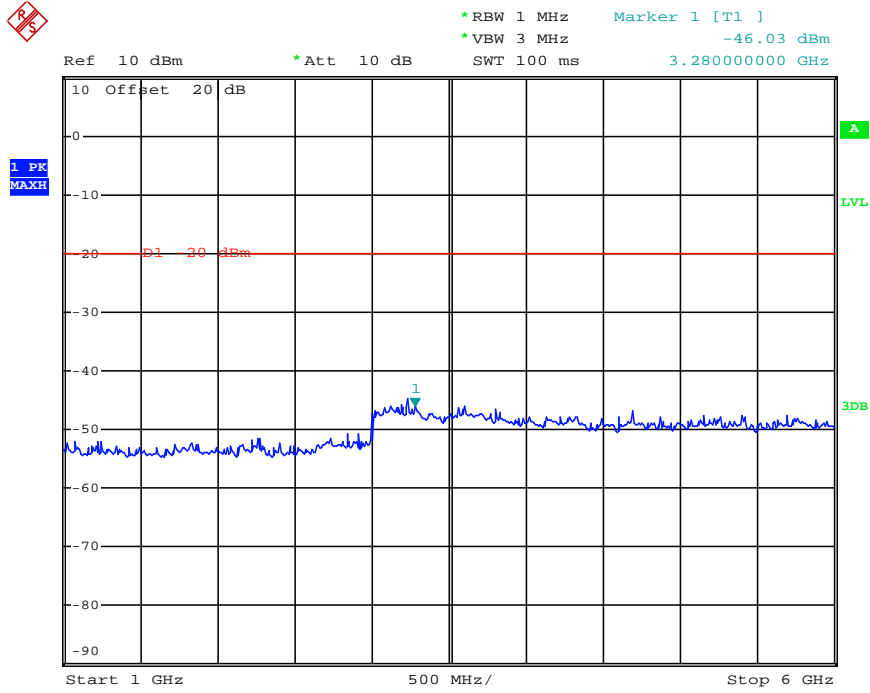

Date: 4.FEB.2013 16:54:23

Modulation Type	Channel Spation	Test Channel	Test Frequency (MHz)	Maximum Conducted Spurious Emissions Below 1GHz		Maximum Conducted Spurious Emissions Above 1GHz		FCC Limit
				Frequency (MHz)	Datum (dBm)	Frequency (MHz)	Datum (dBm)	
4FSK	12.5KHz	High	469.5000	926.00	-49.60	3110.00	-46.36	-20dBm
Test Results				Compliance				

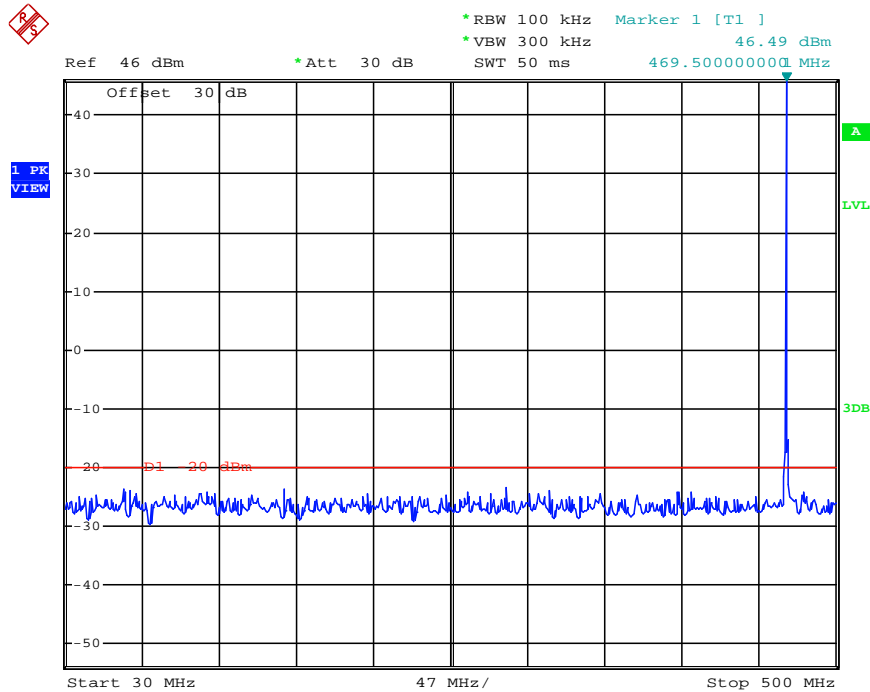

Date: 4.FEB.2013 17:15:25

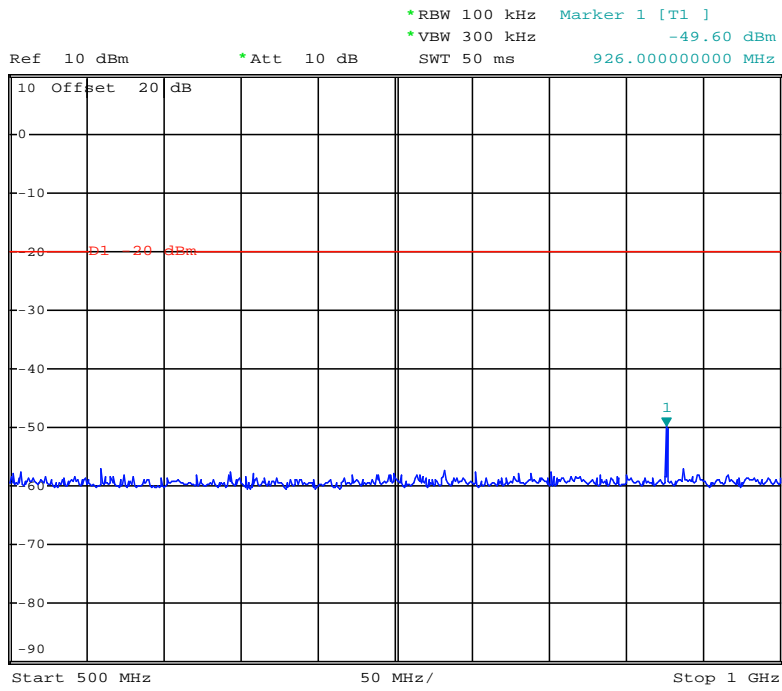

Date: 4.FEB.2013 17:01:53

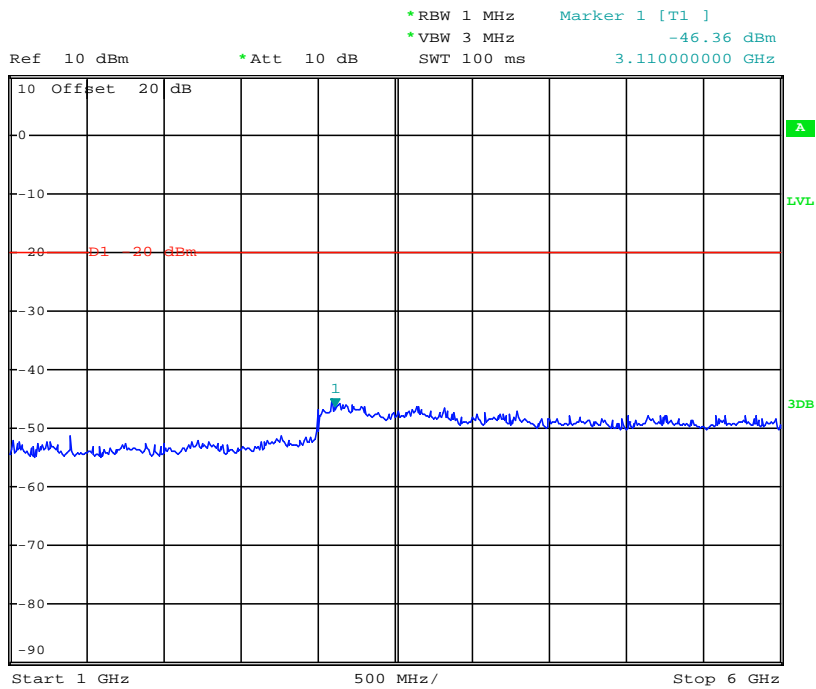

Date: 4.FEB.2013 17:03:37

For Rated Low Power (15Watt)

Modulation Type	Channel Sparation	Test Channel	Test Frequency (MHz)	Maximum Conducted Spurious Emissions Below 1GHz		Maximum Conducted Spurious Emissions Above 1GHz		FCC Limit
				Frequency (MHz)	Datum (dBm)	Frequency (MHz)	Datum (dBm)	
FM	12.5KHz	Low	406.5000	605.00	-58.91	3250.00	-55.22	-20dBm
Test Results				Compliance				

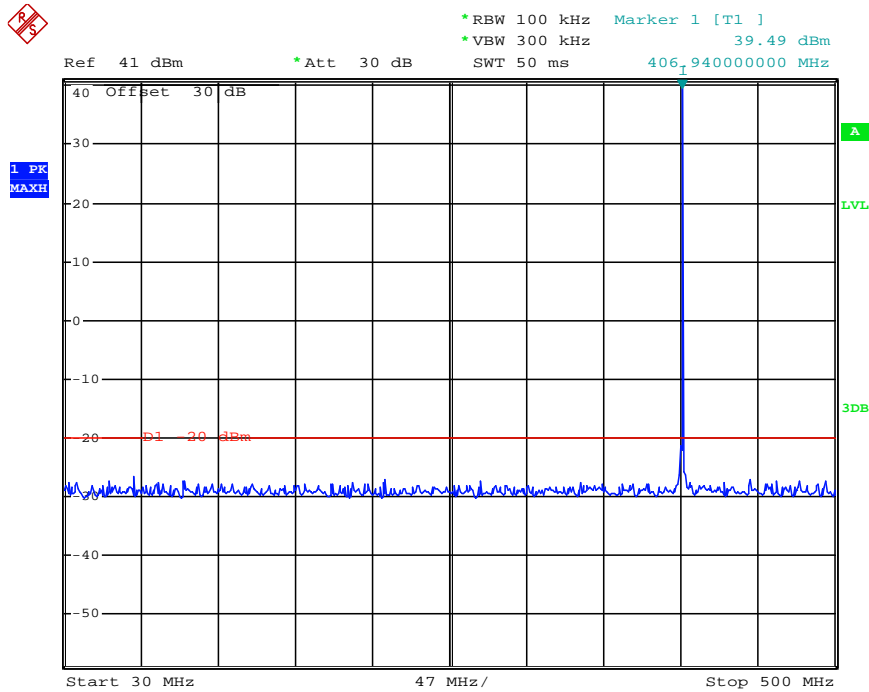

Date: 30.JAN.2013 15:41:24

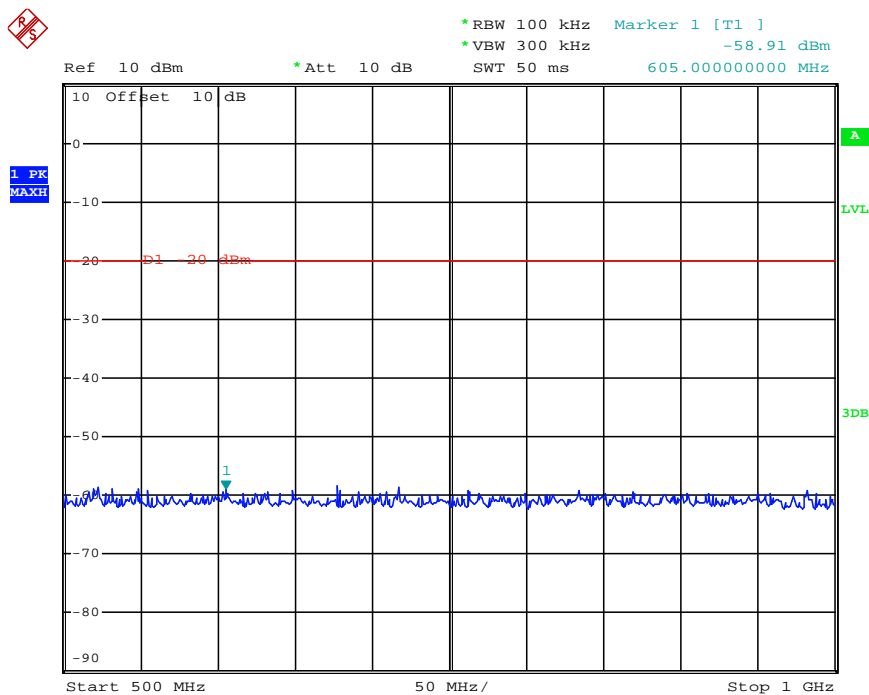

Date: 30.JAN.2013 15:43:47

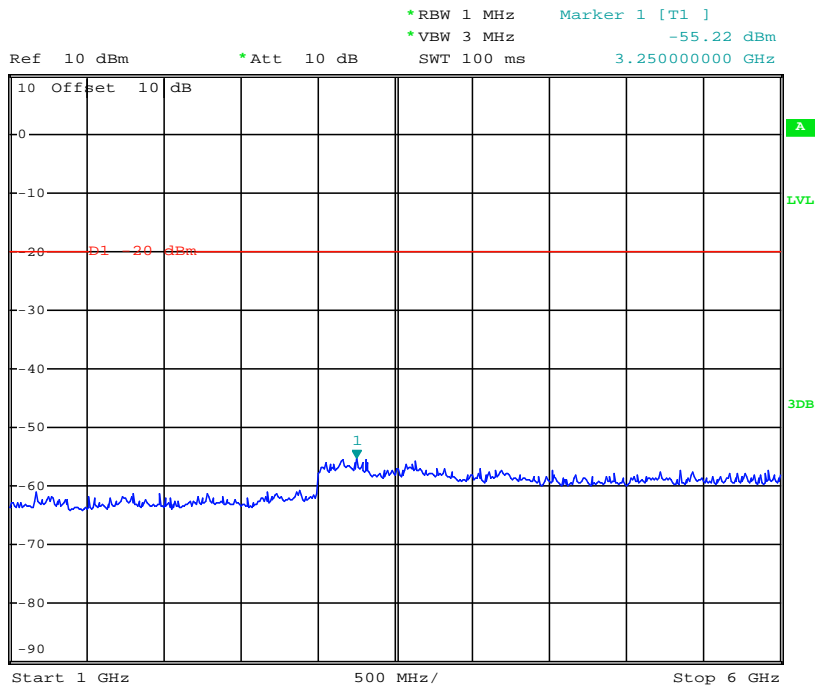

Date: 30.JAN.2013 15:44:58

Modulation Type	Channel Spation	Test Channel	Test Frequency (MHz)	Maximum Conducted Spurious Emissions Below 1GHz		Maximum Conducted Spurious Emissions Above 1GHz		FCC Limit
				Frequency (MHz)	Datum (dBm)	Frequency (MHz)	Datum (dBm)	
FM	12.5KHz	Low	418.0000	836.00	-53.63	3140.00	-55.73	-20dBm
Test Results				Compliance				

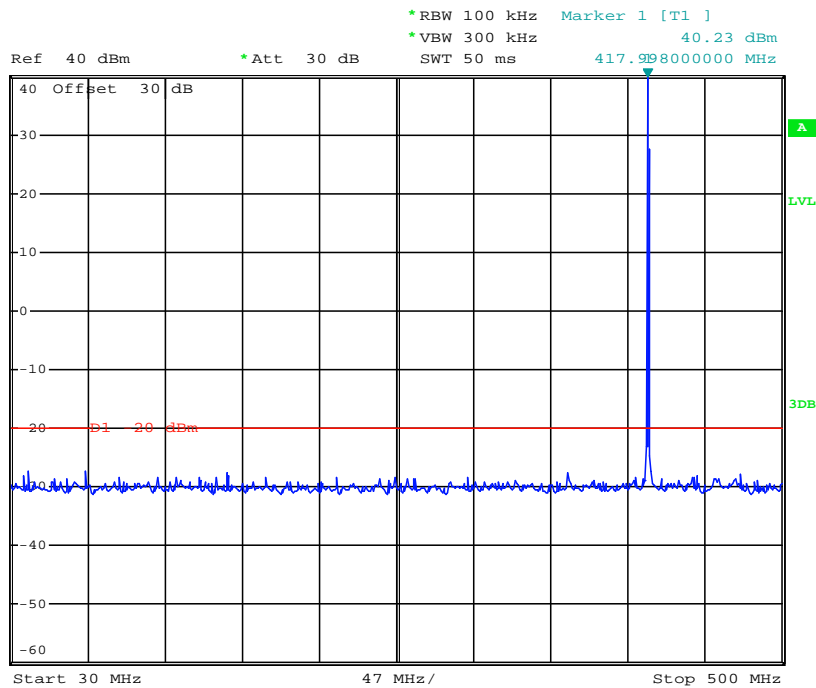

Date: 30.JAN.2013 15:49:58

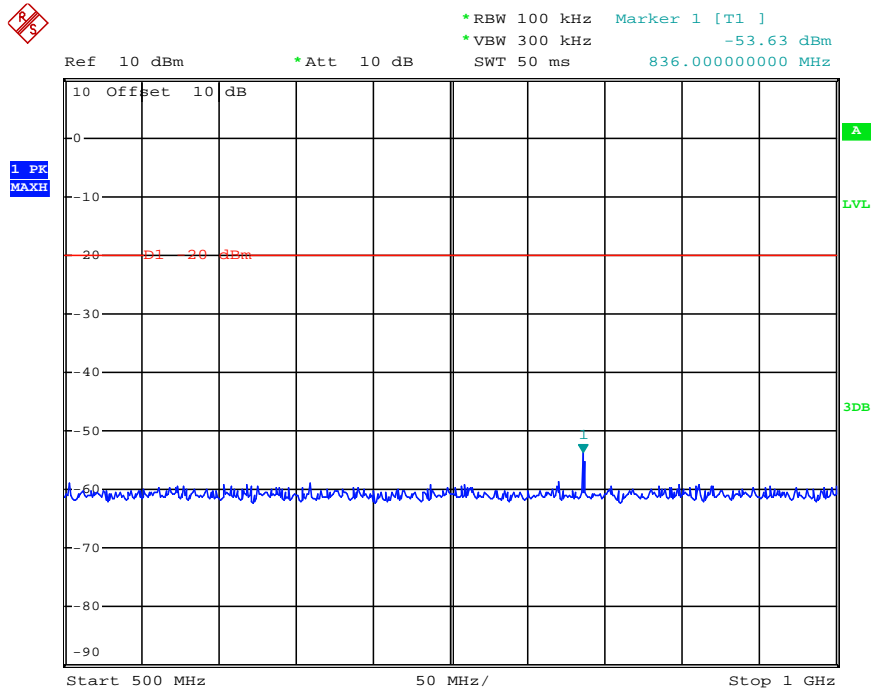

Date: 30.JAN.2013 15:52:52

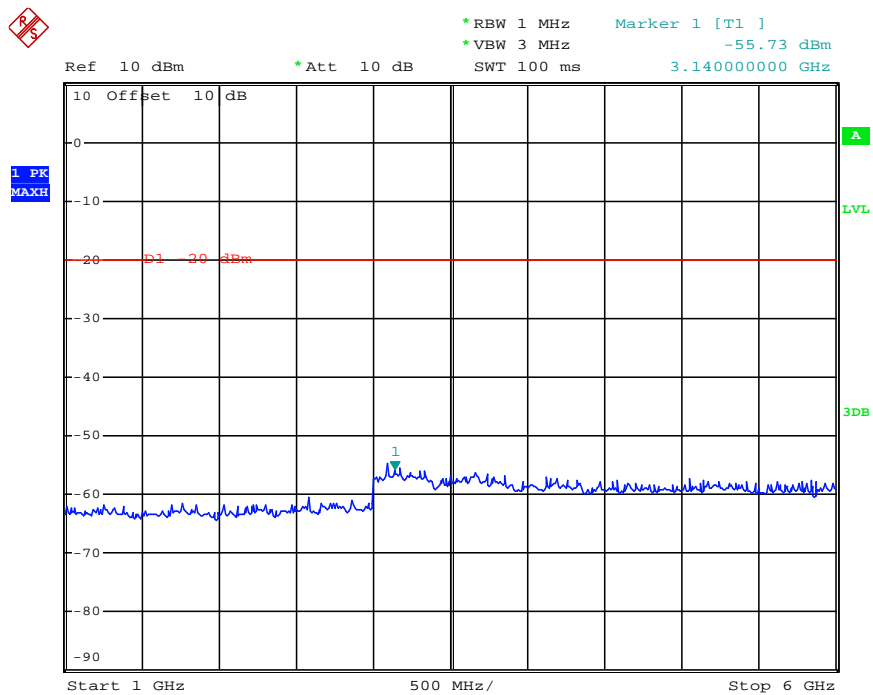

Date: 30.JAN.2013 15:53:17

Modulation Type	Channel Sparation	Test Channel	Test Frequency (MHz)	Maximum Conducted Spurious Emissions Below 1GHz		Maximum Conducted Spurious Emissions Above 1GHz		FCC Limit
				Frequency (MHz)	Datum (dBm)	Frequency (MHz)	Datum (dBm)	
FM	12.5KHz	Middle	435.5000	871.00	-47.76	3080.00	-55.98	-20dBm
Test Results				Compliance				

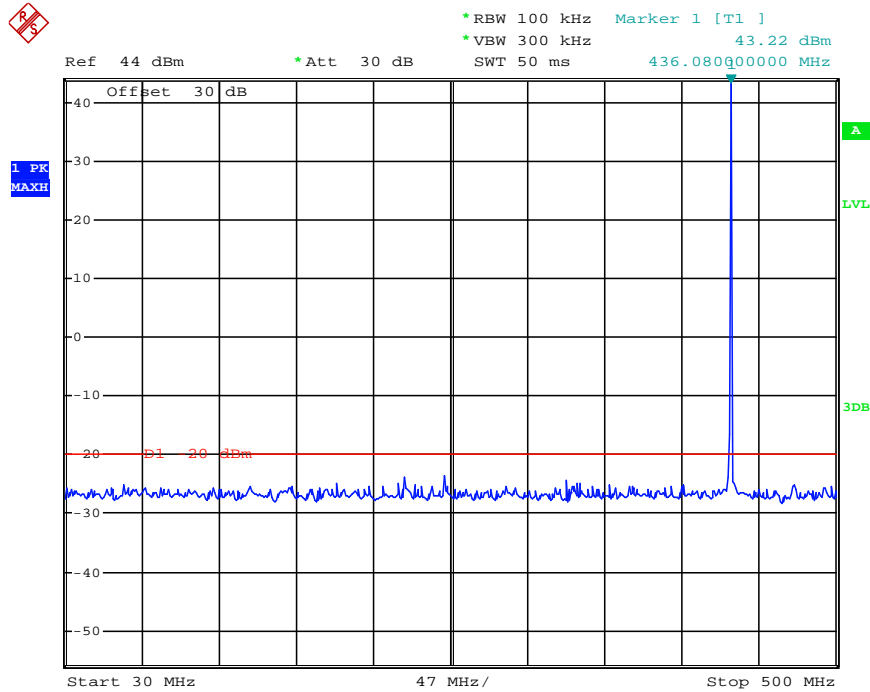

Date: 30.JAN.2013 16:06:32

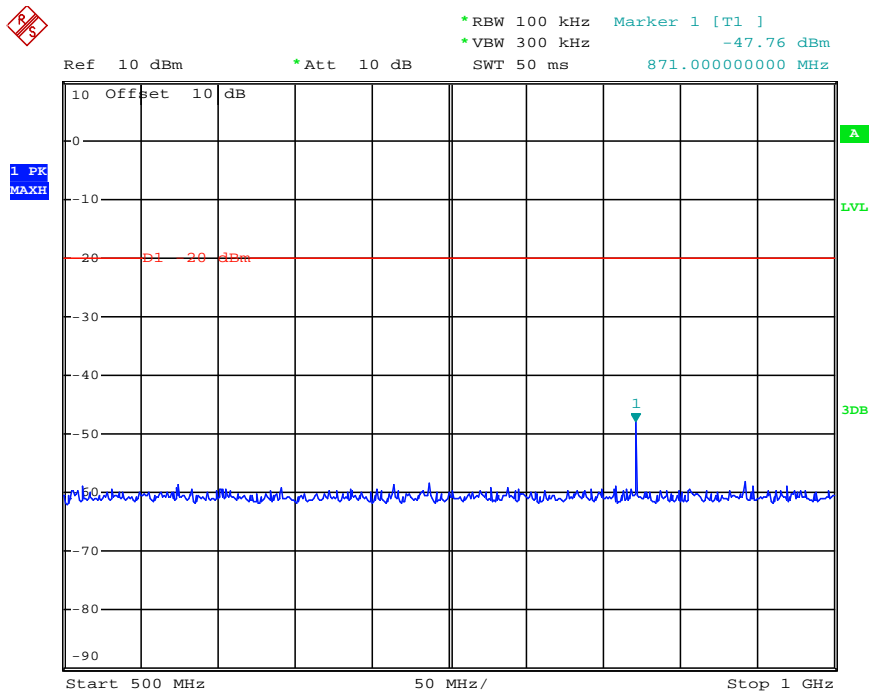

Date: 30.JAN.2013 16:01:23

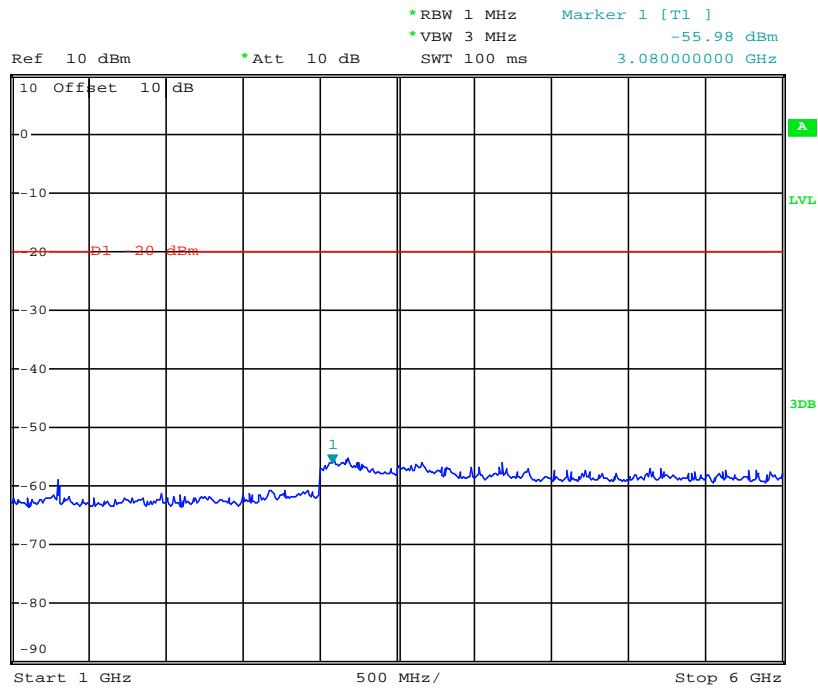

Date: 30.JAN.2013 16:02:49

Modulation Type	Channel Spation	Test Channel	Test Frequency (MHz)	Maximum Conducted Spurious Emissions Below 1GHz		Maximum Conducted Spurious Emissions Above 1GHz		FCC Limit
				Frequency (MHz)	Datum (dBm)	Frequency (MHz)	Datum (dBm)	
FM	12.5KHz	High	453.0000	906.00	-54.50	3210.00	-56.46	-20dBm
Test Results				Compliance				

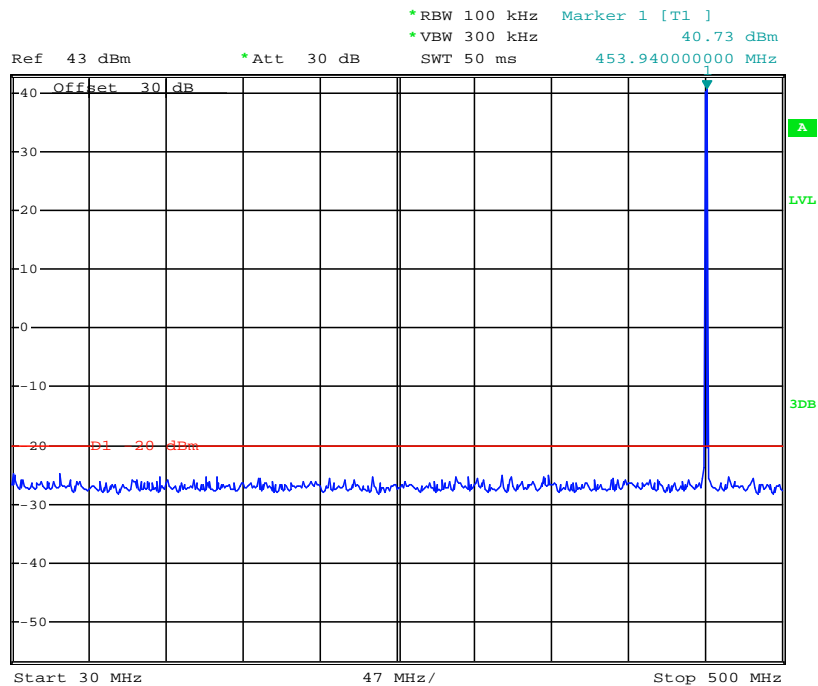

Date: 30.JAN.2013 16:10:36

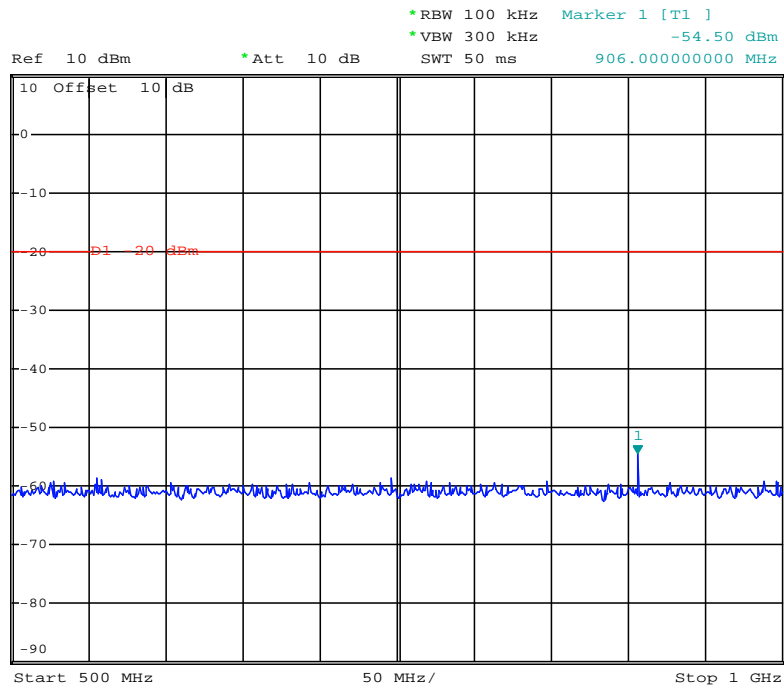

Date: 30.JAN.2013 16:13:22

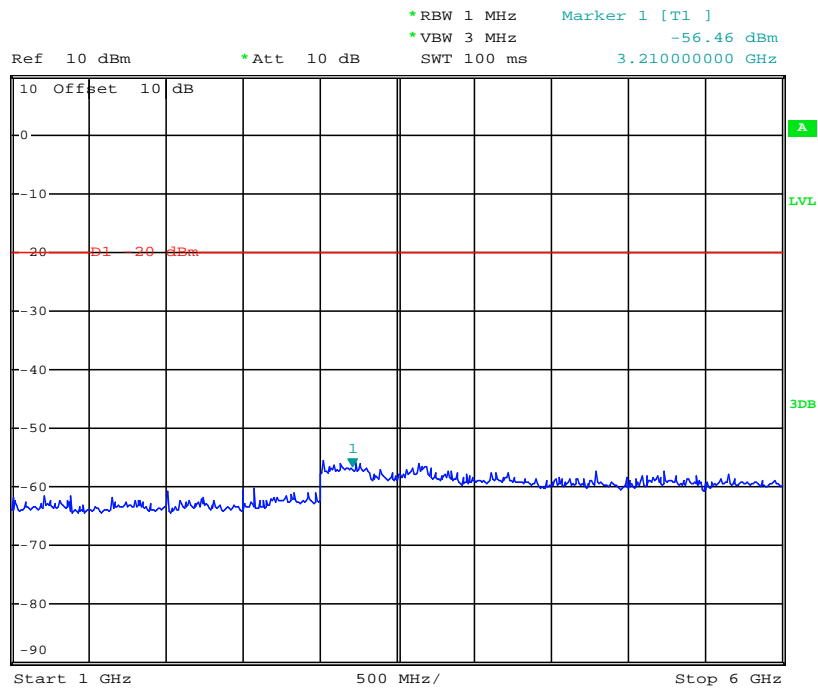

Date: 30.JAN.2013 16:13:41

Modulation Type	Channel Separation	Test Channel	Test Frequency (MHz)	Maximum Conducted Spurious Emissions Below 1GHz		Maximum Conducted Spurious Emissions Above 1GHz		FCC Limit
				Frequency (MHz)	Datum (dBm)	Frequency (MHz)	Datum (dBm)	
FM	12.5KHz	High	469.5000	939.00	-53.71	3190.00	-55.71	-20dBm
Test Results				Compliance				

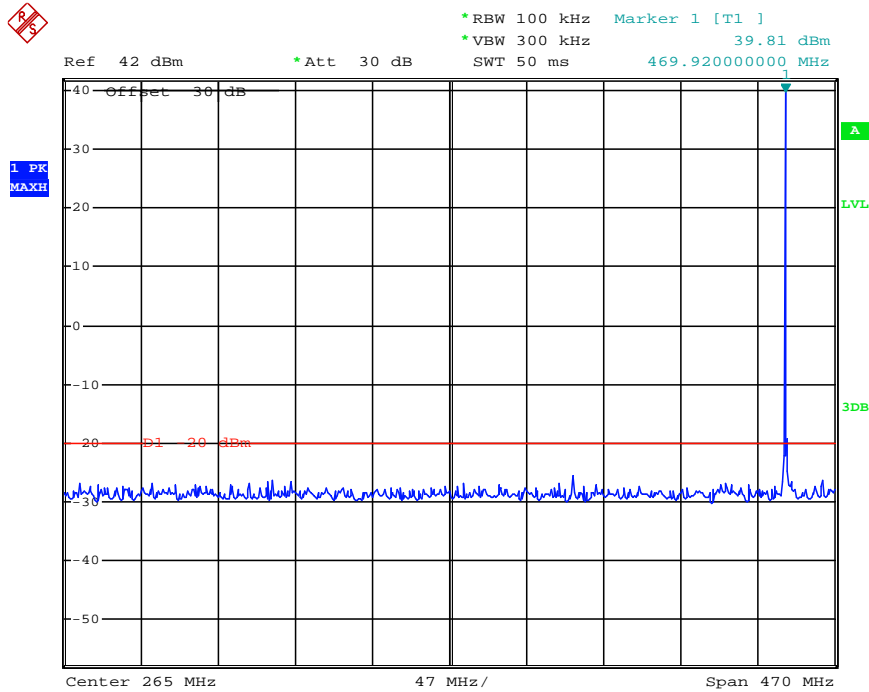

Date: 30.JAN.2013 16:17:53

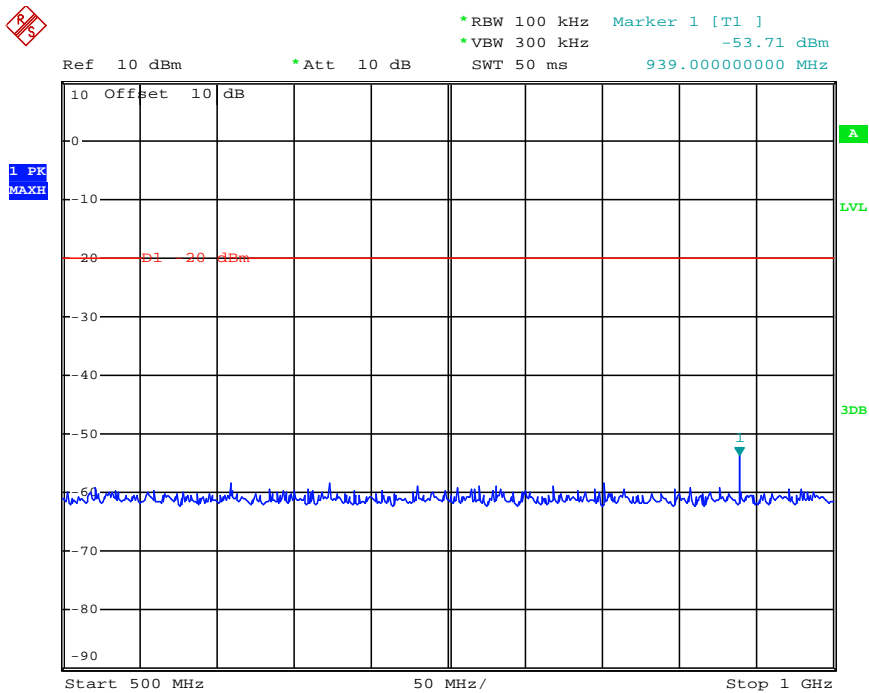

Date: 30.JAN.2013 16:21:05

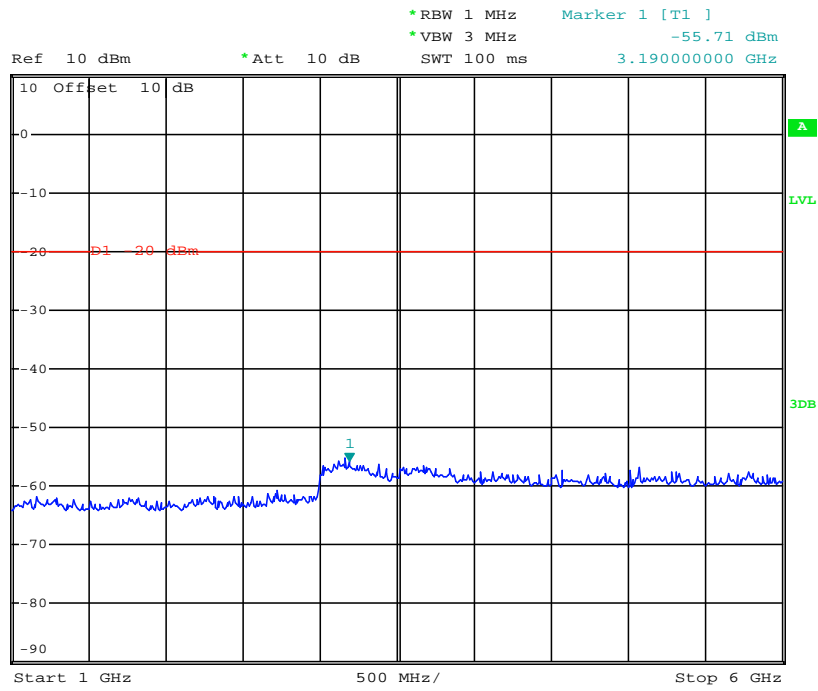

Date: 30.JAN.2013 16:21:24

Modulation Type	Channel Spation	Test Channel	Test Frequency (MHz)	Maximum Conducted Spurious Emissions Below 1GHz		Maximum Conducted Spurious Emissions Above 1GHz		FCC Limit
				Frequency (MHz)	Datum (dBm)	Frequency (MHz)	Datum (dBm)	
4FSk	12.5KHz	Low	406.5000	813.00	-55.09	3190.00	-45.23	-20dBm
Test Results				Compliance				

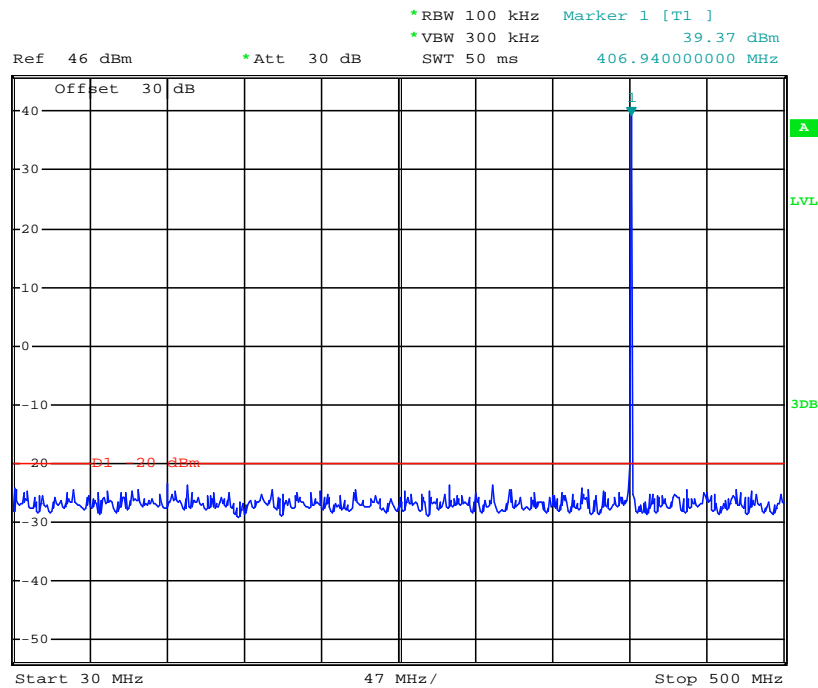

Date: 4.FEB.2013 17:21:37

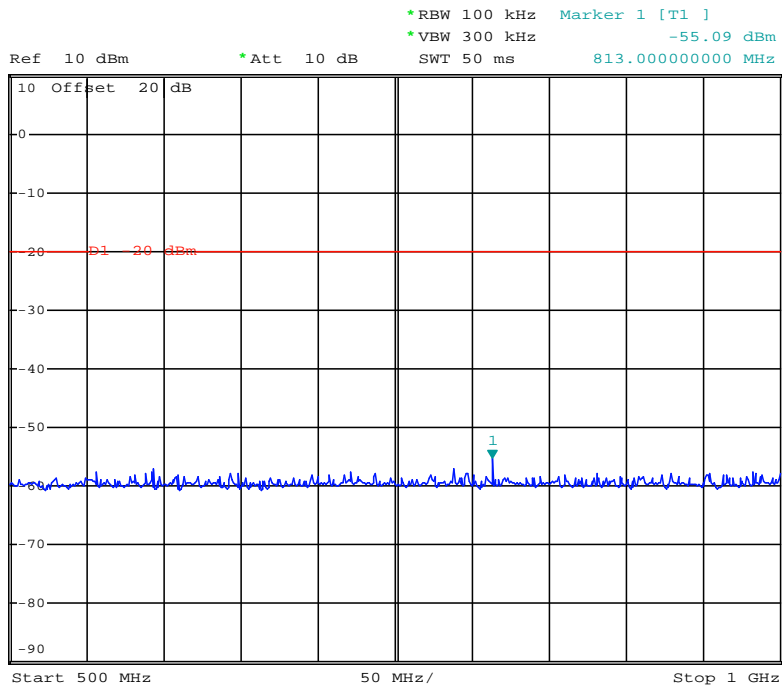

Date: 4.FEB.2013 17:26:07

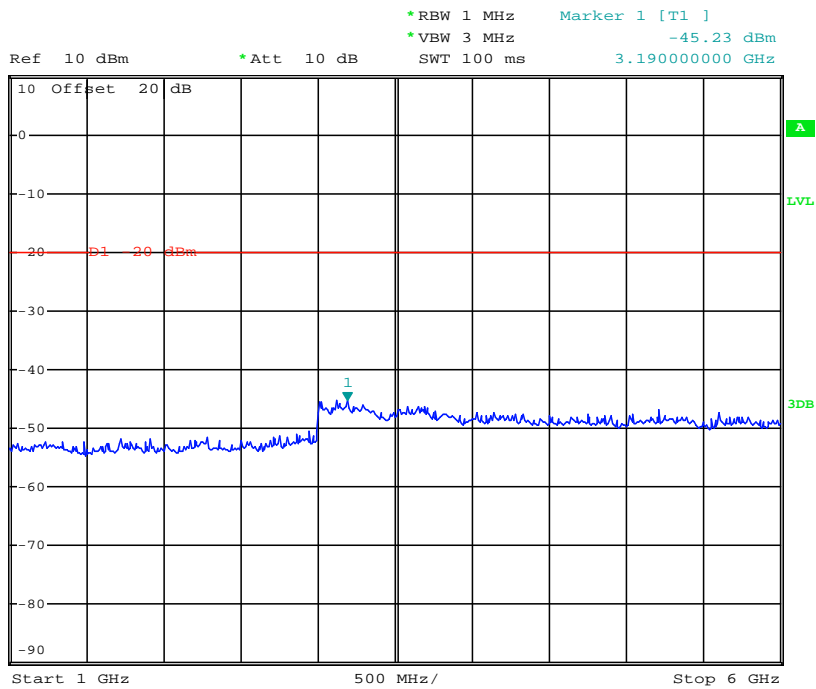

Date: 4.FEB.2013 17:28:06

Modulation Type	Channel Separation	Test Channel	Test Frequency (MHz)	Maximum Conducted Spurious Emissions Below 1GHz		Maximum Conducted Spurious Emissions Above 1GHz		FCC Limit
				Frequency (MHz)	Datum (dBm)	Frequency (MHz)	Datum (dBm)	
4FSK	12.5KHz	Low	418.0000	836.00	-53.63	3140.00	-55.73	-20dBm
Test Results				Compliance				

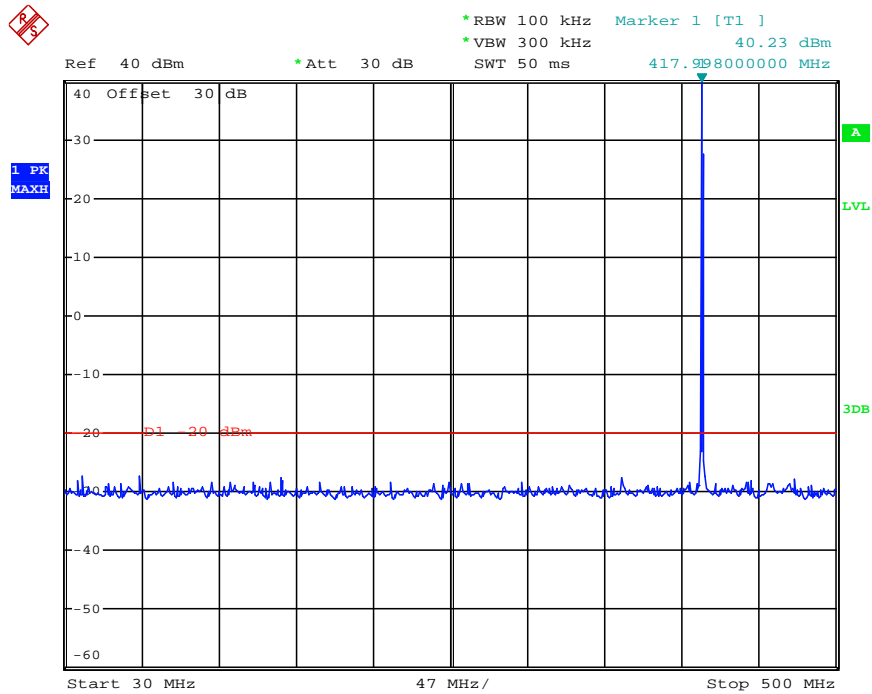

Date: 30.JAN.2013 15:49:58

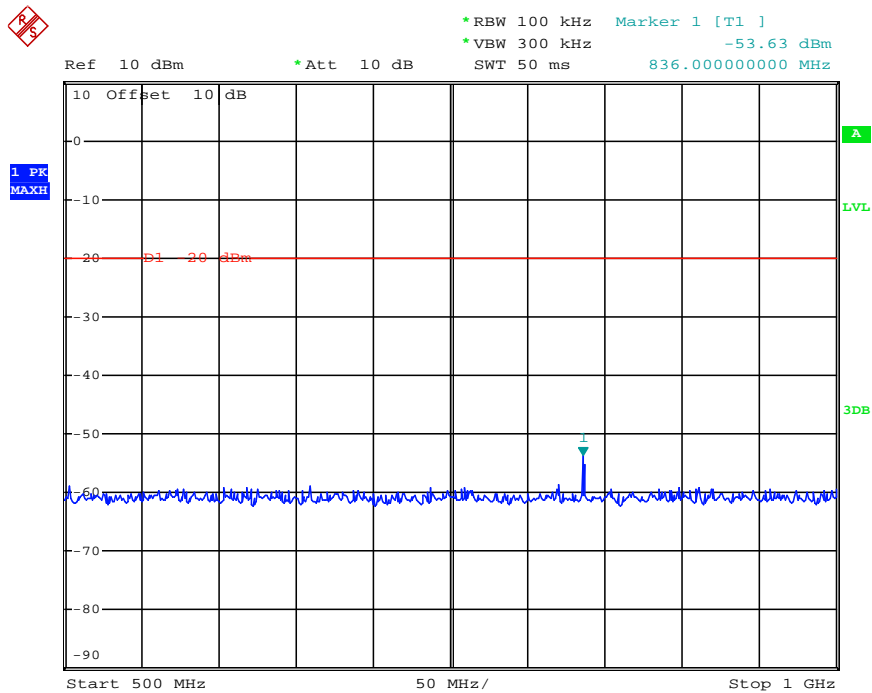

Date: 30.JAN.2013 15:52:52

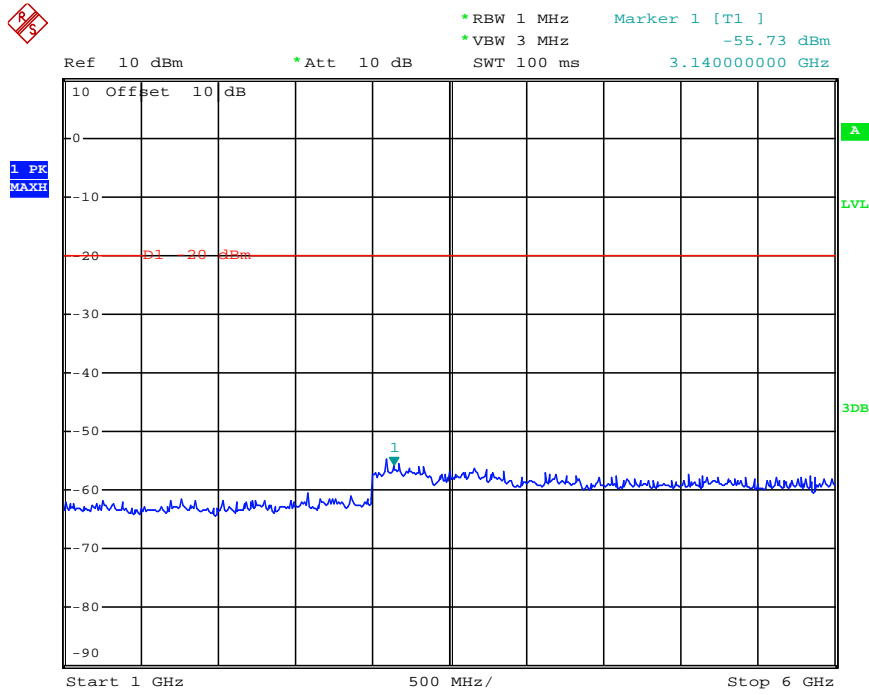

Date: 30.JAN.2013 15:53:17

Modulation Type	Channel Spation	Test Channel	Test Frequency (MHz)	Maximum Conducted Spurious Emissions Below 1GHz		Maximum Conducted Spurious Emissions Above 1GHz		FCC Limit
				Frequency (MHz)	Datum (dBm)	Frequency (MHz)	Datum (dBm)	
4FSK	12.5KHz	Middle	435.5000	871.00	-46.12	3140.00	-45.09	-20dBm
Test Results				Compliance				

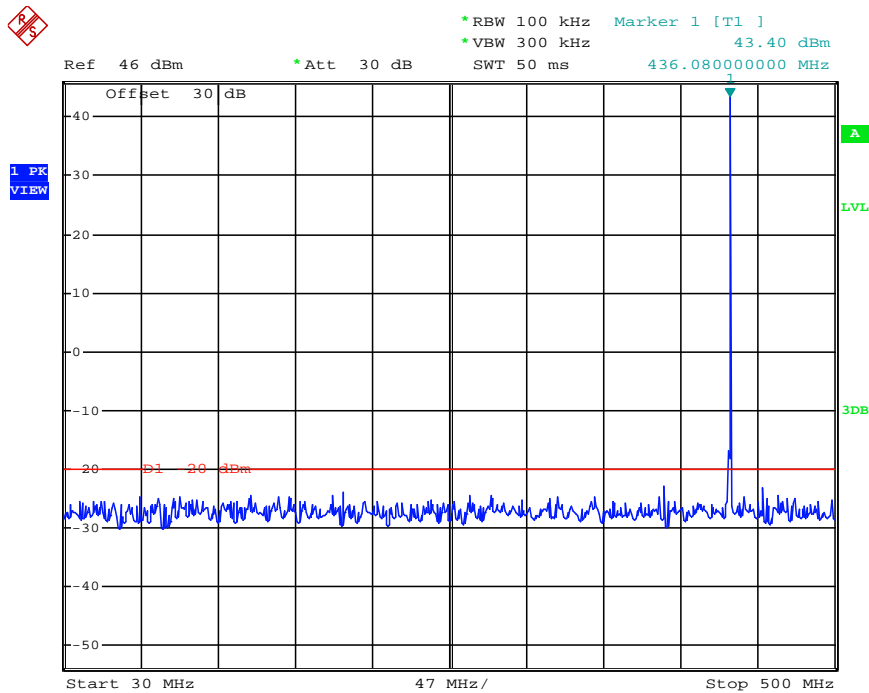

Date: 4.FEB.2013 17:36:51

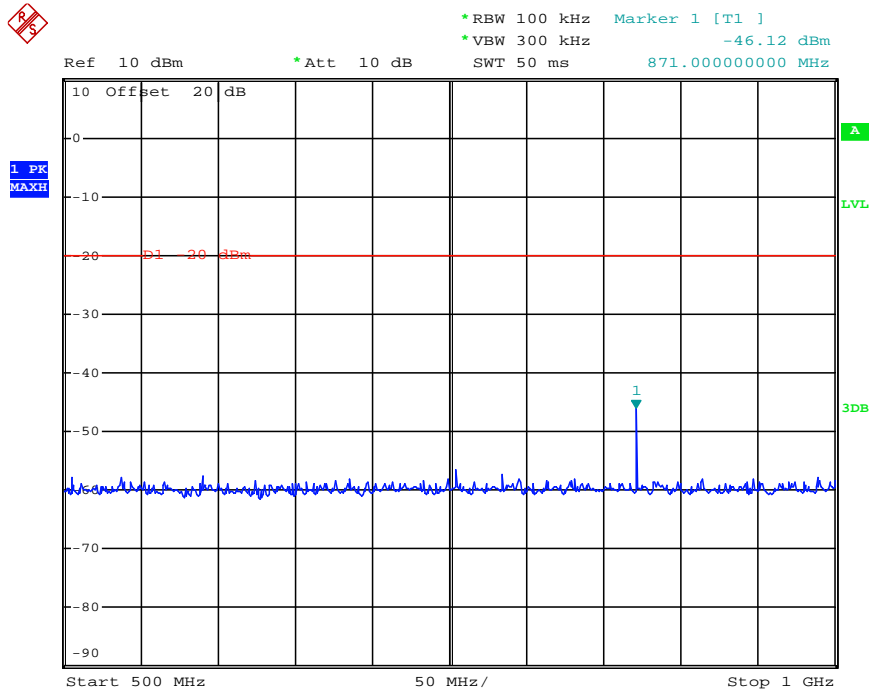

Date: 4.FEB.2013 17:33:50

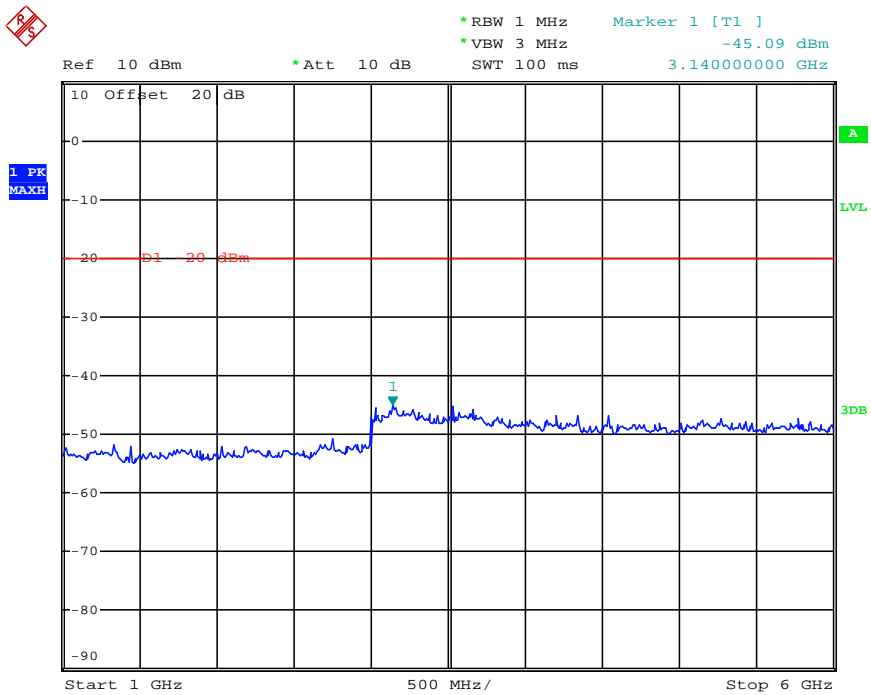

Date: 4.FEB.2013 17:32:23

Modulation Type	Channel Separation	Test Channel	Test Frequency (MHz)	Maximum Conducted Spurious Emissions Below 1GHz		Maximum Conducted Spurious Emissions Above 1GHz		FCC Limit
				Frequency (MHz)	Datum (dBm)	Frequency (MHz)	Datum (dBm)	
4FSK	12.5KHz	High	453.0000	906.00	-42.89	3280.00	-46.03	-20dBm
Test Results				Compliance				

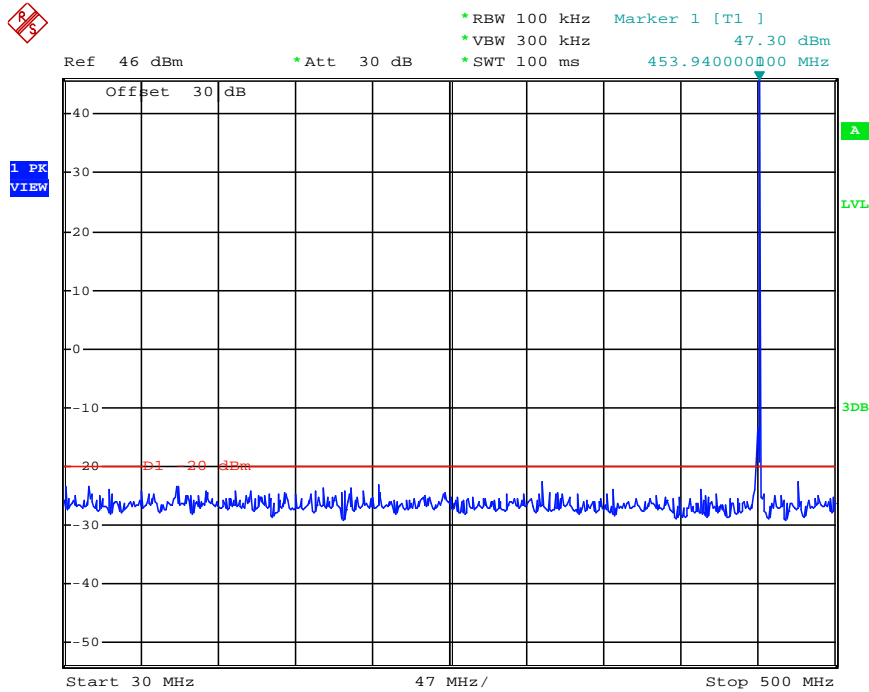

Date: 4.FEB.2013 16:15:50

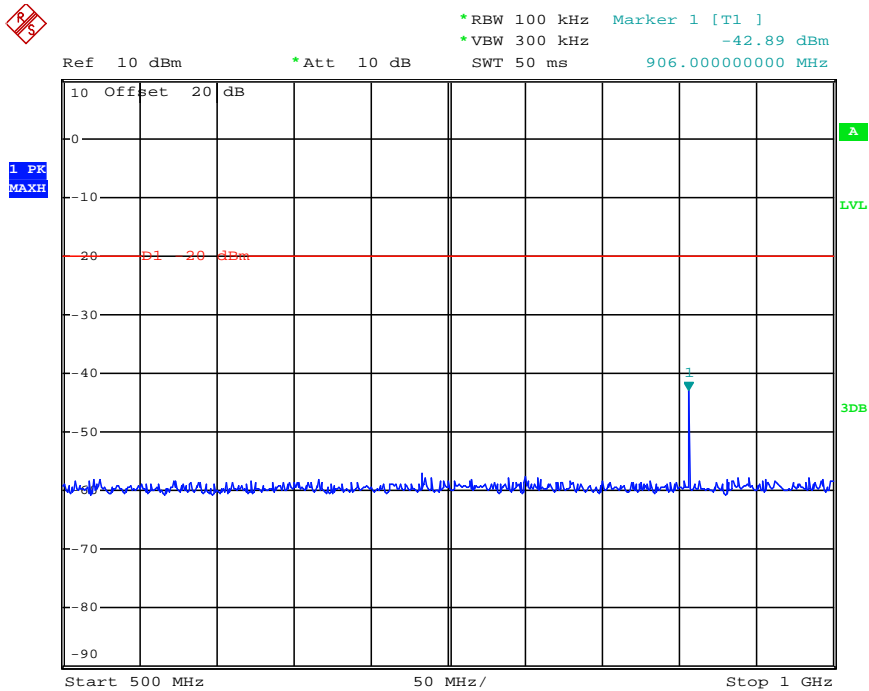

Date: 4.FEB.2013 16:53:34

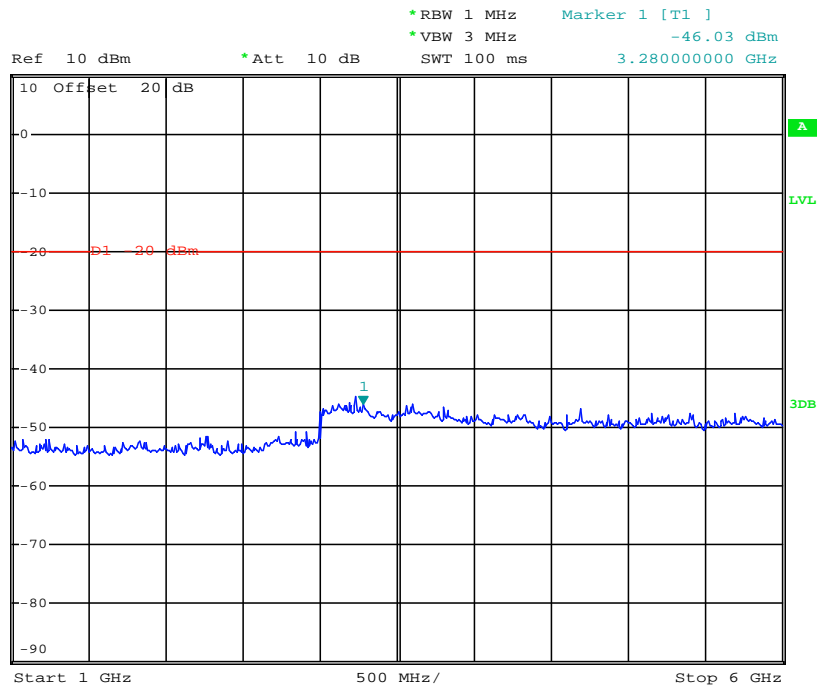

Date: 4.FEB.2013 16:54:23

Modulation Type	Channel Spation	Test Channel	Test Frequency (MHz)	Maximum Conducted Spurious Emissions Below 1GHz		Maximum Conducted Spurious Emissions Above 1GHz		FCC Limit
				Frequency (MHz)	Datum (dBm)	Frequency (MHz)	Datum (dBm)	
4FSK	12.5KHz	High	469.5000	926.00	-56.82	3200.00	-44.89	-20dBm
Test Results				Compliance				

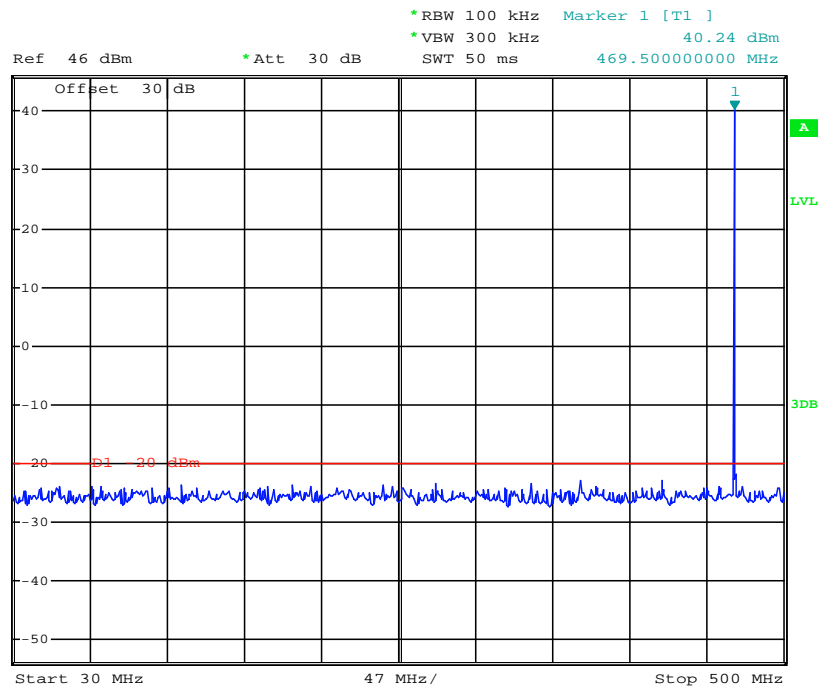

Date: 4.FEB.2013 17:15:57

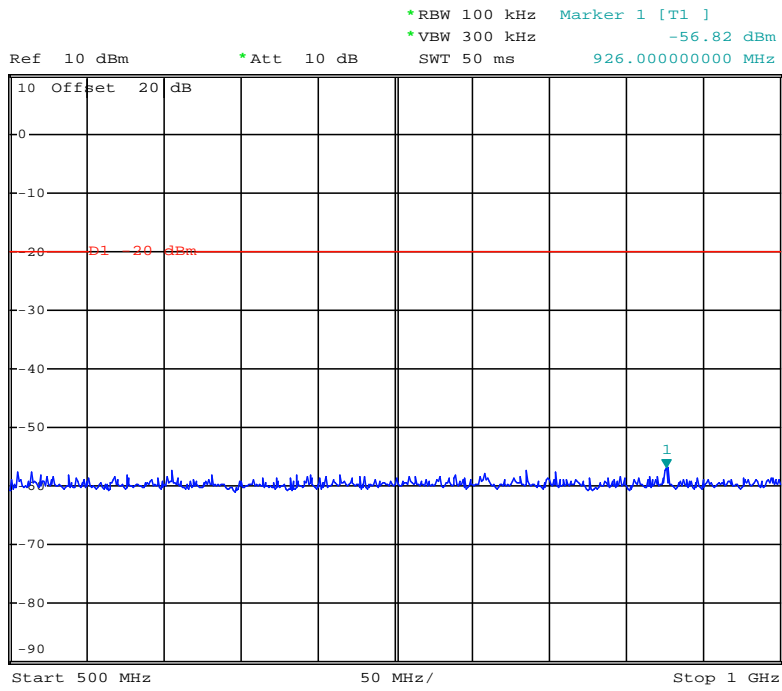

Date: 4.FEB.2013 17:02:28

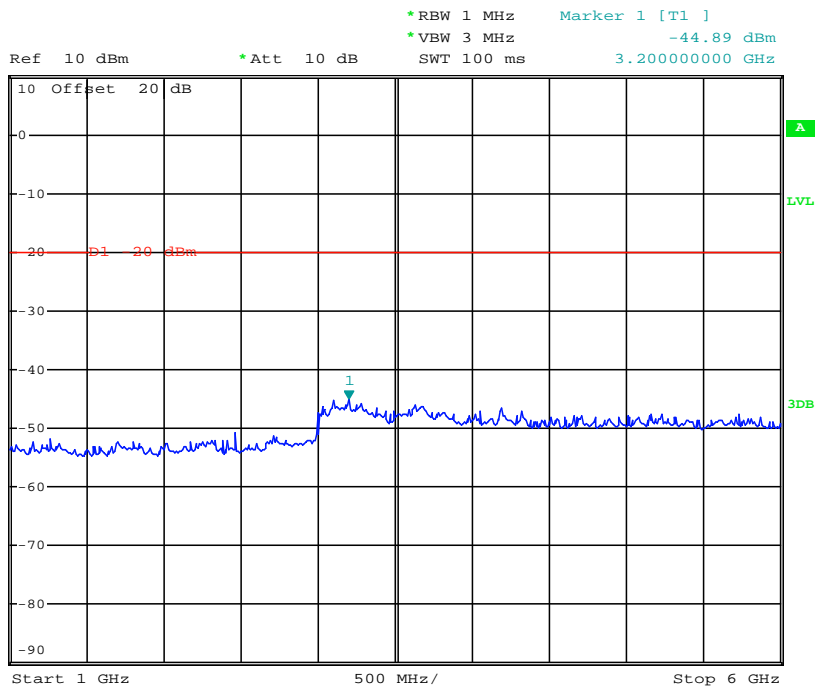

Date: 4.FEB.2013 17:03:54

4.5. Modulation Characteristics

TEST APPLICABLE

According to CFR47 section 2.1047(a), for Voice Modulation Communication Equipment, the frequency response of the audio modulation circuit over a range of 100 to 5000Hz shall be measured.

TEST PROCEDURE

Modulation Limit

- 1 Configure the EUT as shown in figure 1, adjust the audio input for 60% of rated system deviation at 1 KHz using this level as a reference (0dB) and vary the input level from -20 to +20dB. Record the frequency deviation obtained as a function of the input level.
- 2 Repeat step 1 with input frequency changing to 300, 1004, 1500 and 2500Hz in sequence.

Audio Frequency Response

- 1 Configure the EUT as shown in figure 1.
- 2 Adjust the audio input for 20% of rated system deviation at 1 KHz using this level as a reference (0dB).
- 3 Vary the Audio frequency from 100 Hz to 3 KHz and record the frequency deviation.
- 4 Audio Frequency Response = $20 \log_{10} (\text{Deviation of test frequency} / \text{Deviation of 1 KHz reference})$.

TEST CONFIGURATION

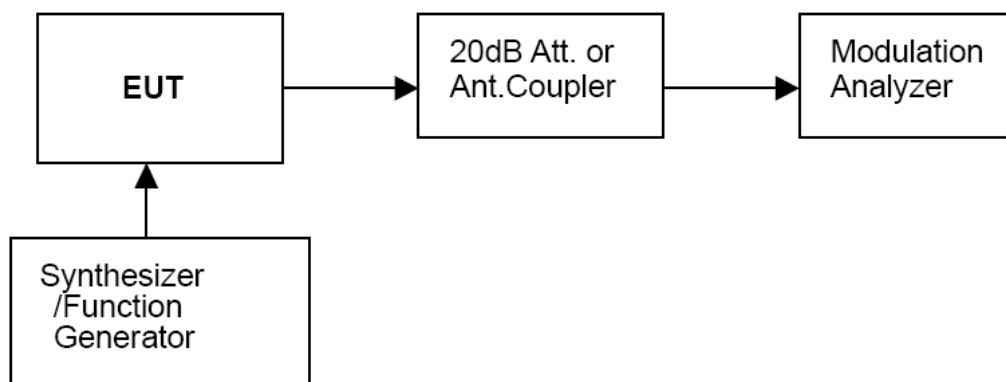

TEST RESULTS

Modulation Type: FM

12.5 KHz Channel Separation

Modulation Level(dB)	Peak Freq. Deviation At 300 Hz(KHz)	Peak Freq. Deviation At 1004 H(KHz)	Peak Freq. Deviation At 1500 Hz(KHz)	Peak Freq. Deviation At 2500 Hz(KHz)
-20	0.20	0.20	0.32	0.53
-15	0.23	0.43	0.50	0.75
-10	0.25	0.62	0.81	1.08
-5	0.30	0.91	1.36	2.15
0	0.52	1.85	2.22	2.21
+5	0.82	2.28	2.29	2.26
+10	1.31	2.30	2.34	2.28
+15	2.20	2.34	2.34	2.30
+20	2.33	2.34	2.34	2.30

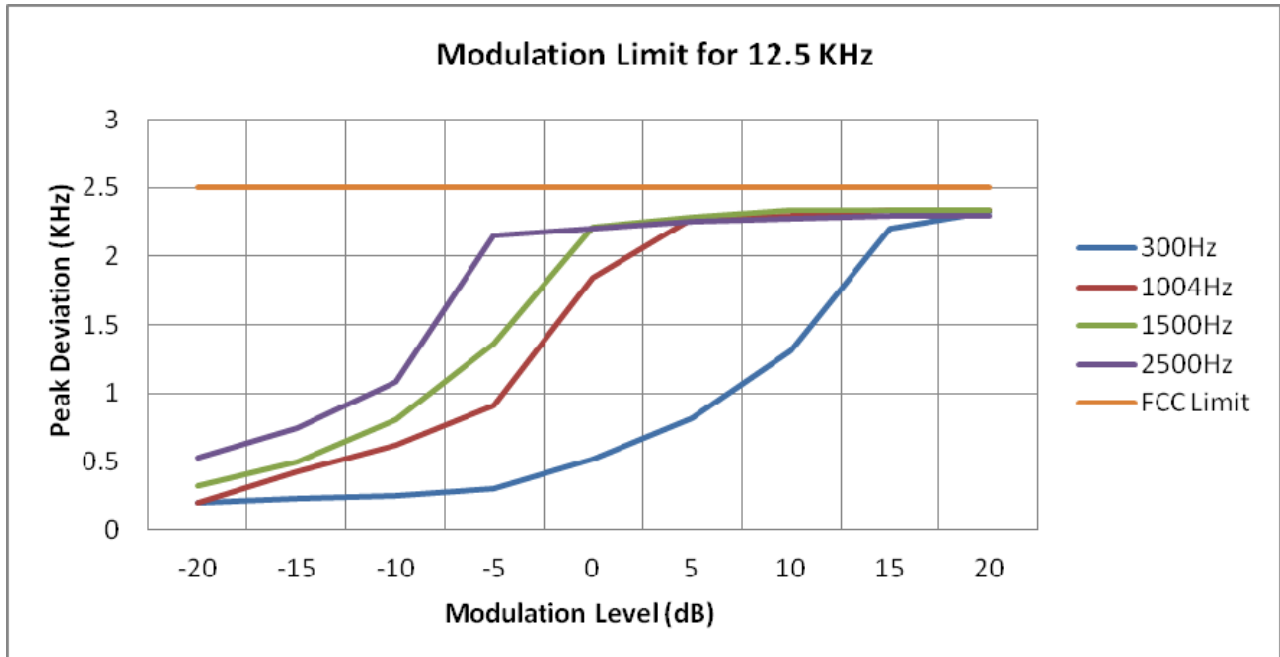

Modulation type: 4FSK

Channel bandwidth: 12.5 kHz

It is not applicable for devices which operate with the digitized voice/data modulation type.

b). Audio Frequency Response:

Rule Part No.: Part 2.1407(a) (b)

Method of Measurement:

The audio frequency response was measured in accordance with TIA/EIA Specification 603 with no exception. A curve or equivalent data showing the frequency response of the audio modulating circuit over a range of 300-3000Hz shall be submitted and Audio Post Limiter Low Pass Filter Response from 3.0 KHz to 50KHz. However, the audio frequency response should test from 100Hz to 5.0 KHz according to FCC Part 90.

Modulation Type: FM

The audio frequency response curve is show below.and

Test Audio Level (1 KHz and 20% maximum deviation) is 2.70mv for 12.5 KHz channel separation.

Note:

1. Not applicable to new standard. However, tests are conducted under FCC's recommendation.
2. The Audio Frequency Response is identical for 12.5 KHz channel separation

12.5 KHz Channel Separation

Frequency (KHz)	Frequency Deviation (KHz)	1KHz Reference Deviation (KHz)	Audio Frequency Response (dB)
0.1	0.05	0.50	-20.00
0.2	0.05	0.50	-20.00
0.3	0.15	0.50	-10.46
0.4	0.15	0.50	-10.46
0.5	0.21	0.50	-7.54
0.6	0.30	0.50	-4.44
0.7	0.32	0.50	-3.88
0.8	0.35	0.50	-3.10
0.9	0.42	0.50	-1.51
1.0	0.50	0.50	0.00
1.2	0.55	0.50	0.83
1.4	0.64	0.50	2.14
1.6	0.75	0.50	3.52
1.8	0.84	0.50	4.51
2.0	0.90	0.50	5.11
2.2	1.02	0.50	6.19
2.4	1.12	0.50	7.00
2.6	1.21	0.50	7.68
2.7	1.21	0.50	7.68
2.8	1.22	0.50	7.75
3.0	1.26	0.50	8.03
3.5	0.06	0.50	-18.42
4.0	0.05	0.50	-20.00
4.5	0.03	0.50	-24.44
5.0	0.03	0.50	-24.44

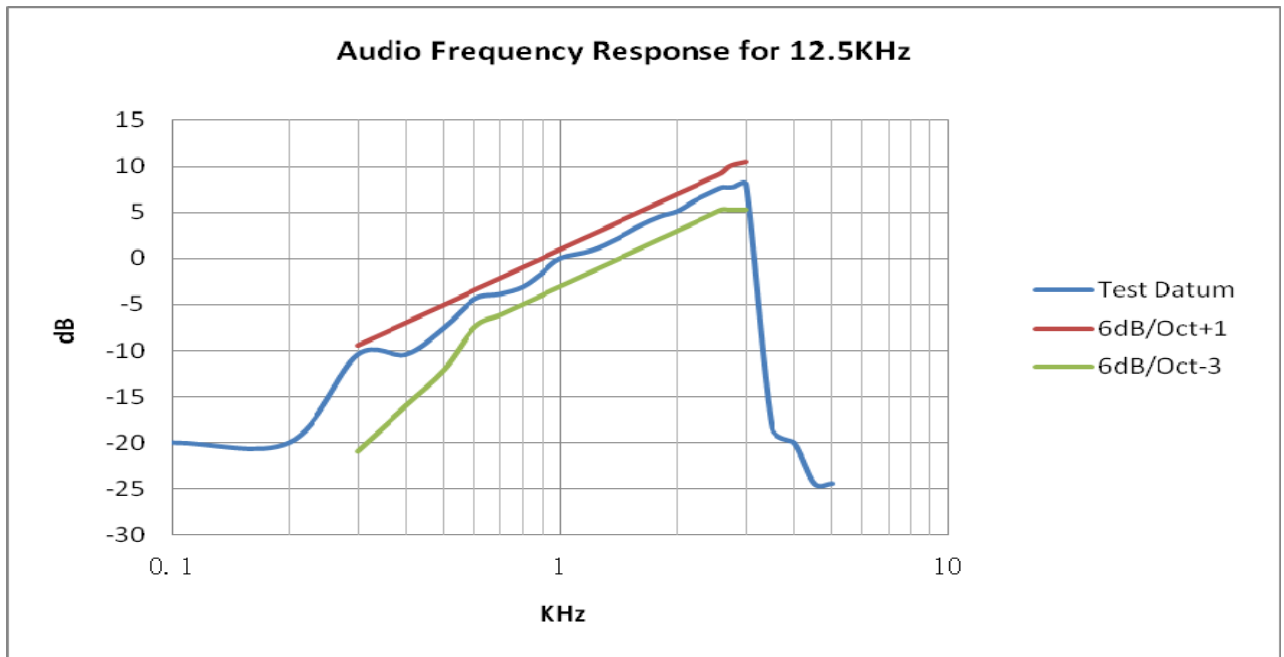

Modulation Type: 4FSK

Channel bandwidth: 12.5 kHz

It is not applicable for devices which operate with the digitized voice/data modulation type.

4.6. Frequency Stability Test

TEST APPLICABLE

1. According to FCC Part 2 Section 2.1055 (a)(1), the frequency stability shall be measured with variation of ambient temperature from -30°C to +50°C centigrade.
2. According to FCC Part 2 Section 2.1055 (a) (2), for battery powered equipment, the frequency stability shall be measured with reducing primary supply voltage to the battery operating end point, which is specified by the manufacture.
3. Vary primary supply voltage from 85 to 115 percent of the nominal value for other than hand carried voltage equipment and the end voltage point was 120V.
4. According to §90.213, the frequency stability limit is 1.5 ppm for 12.5KHz channel separation

TEST PROCEDURE

The EUT was set in the climate chamber and connected to an external AC power supply. The RF output was directly connected to Spectrum Analyzer ESI 26. The coupling loss of the additional cables was recorded and taken in account for all the measurements. After temperature stabilization (approx. 20 min for each stage), the frequency for the lower, the middle and the highest frequency range was recorded. For Frequency stability Vs. Voltage the EUT was connected to a AC power supply and the voltage was adjusted in the required ranges. The result was recorded.

TEST CONFIGURATION

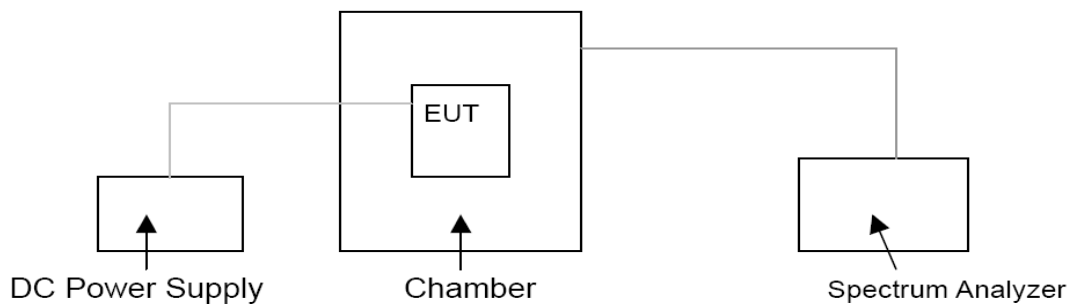

TEST LIMITS

According to 90.213, Transmitters used must have minimum frequency stability as specified in the following table.

Frequency Range (MHz)	Channel Bandwidth (KHz)	Frequency Tolerance (ppm)		
		Fixed and Base Stations	Mobile Stations	
			> 2 W	≤ 2 W
150-174 MHz	6.25	1.0	2.0	2.0
	12.5	2.5	5.0	5.0
	25	5.0	5.0	50.0*
421-512 MHz	6.25	0.5	1.0	1.0
	12.5	1.5	2.5	2.5
	25	2.5	5.0	5.0

- Stations operating in the 154.45 to 154.49 MHz or the 173.2 to 173.4 MHz bands must have a frequency stability of 5 ppm.
- Paging transmitters operating on paging-only frequencies must operate with frequency stability of 5 ppm in the 150-174 MHz band and 2.5 ppm in the 421-512 MHz band.

TEST RESULTS

Modulation Type	Channel Separation	Test conditions		Frequency error (ppm)				
		Voltage(V)	Temp(°C)	406.5	418	435.5	453	469.5
Analog/FM	12.5KHz	120	-30	0.53	0.52	0.51	0.51	0.49
			-20	0.53	0.50	0.49	0.48	0.47
			-10	0.42	0.41	0.43	0.44	0.43
			0	0.36	0.35	0.35	0.32	0.32
			10	0.25	0.26	0.26	0.29	0.25
			20	0.20	0.23	0.21	0.22	0.20
			30	0.23	0.23	0.22	0.22	0.22
			40	0.42	0.35	0.30	0.30	0.33
			50	0.49	0.47	0.44	0.41	0.39
		102 (85% Rated)	20	0.22	0.23	0.21	0.22	0.20
		138 (115% Rated)	20	0.25	0.23	0.22	0.20	0.22
Limit			1.5 ppm					
Conclusion			Complies					

Modulation Type	Channel Separation	Test conditions		Frequency error (ppm)				
		Voltage(V)	Temp(°C)	406.5	418	435.5	453	469.5
Digital/4FSK	12.5KHz	120	-30	0.53	0.52	0.52	0.51	0.49
			-20	0.51	0.50	0.50	0.48	0.45
			-10	0.45	0.44	0.43	0.43	0.45
			0	0.40	0.35	0.33	0.32	0.31
			10	0.25	0.26	0.26	0.25	0.25
			20	0.23	0.23	0.22	0.22	0.20
			30	0.23	0.23	0.22	0.22	0.20
			40	0.42	0.39	0.35	0.33	0.33
			50	0.51	0.50	0.48	0.41	0.41
		102 (85% Rated)	20	0.23	0.23	0.21	0.22	0.20
		138 (115% Rated)	20	0.23	0.23	0.21	0.22	0.20
Limit			1.5 ppm					
Conclusion			Complies					

4.7. Maximum Transmitter Power

TEST APPLICABLE

Per FCC «2.1046 and «90.205: Maximum ERP is dependent upon the station's antenna HAAT and required service area.

TEST PROCEDURE

Measurements shall be made to establish the radio frequency power delivered by the transmitter the standard output termination. The power output shall be monitored and recorded and no adjustment shall be made to the transmitter after the test has begun, except as noted below:

If the power output is adjustable, measurements shall be made for the highest and lowest power levels.

The EUT connect to the Receiver through 20 dB attenuator.

Measurement with Spectrum Analyzer FSP40 conducted, external power supply with 120 V/60Hz

TEST CONFIGURATION

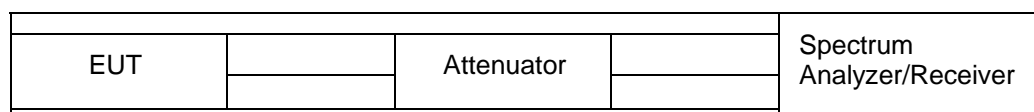

The EUT was directly connected to a RF Communication
Test set by a 20 dB attenuator

TEST RESULTS

Modulation Type	Channel Separation	Test Channel	Test Frequency	Maximum Transmitter Power at Rated High Power Level(dBm)	Maximum Transmitter Power at Rated Low Power Level(dBm)
Analog/FM	12.5KHz	Low Channel	406.5000 MHz	47.44	39.49
		Low Channel	418.0000 MHz	46.18	41.22
		Middle Channel	435.5000 MHz	47.61	42.56
		High Channel	453.0000 MHz	47.37	41.27
		High Channel	469.5000 MHz	46.53	40.25
Digital/4FSK	12.5KHz	Low Channel	406.5000 MHz	47.38	39.55
		Low Channel	418.0000 MHz	46.17	41.22
		Middle Channel	435.5000 MHz	47.57	42.26
		High Channel	453.0000 MHz	47.19	41.79
		High Channel	469.5000 MHz	46.47	40.87
Limit	The limit is dependent upon the station's antenna HAAT and required service area.				
Test Results	Complicance				

Plots of Maximum Transmitter Power Measurement

Modulation Type	Channel Separation	Freq.(MHz)	Rated Power (Watt)	Measurement (dBm)	FCC Limit	Results
FM	12.5 KHz	406.5000	50	47.44	Varies	Complicance

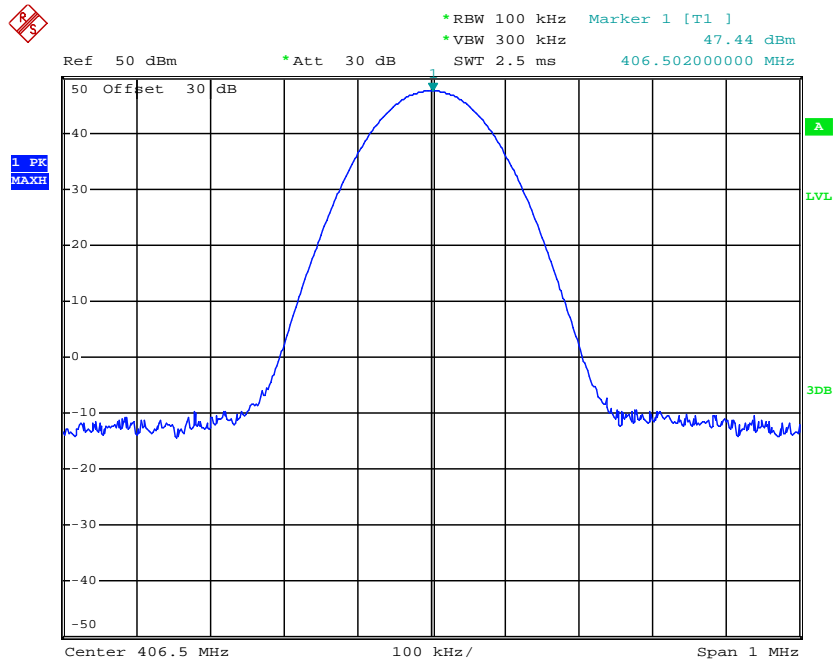

Date: 4.FEB.2013 17:23:11

Modulation Type	Channel Separation	Freq.(MHz)	Rated Power (Watt)	Measurement (dBm)	FCC Limit	Results
FM	12.5 KHz	418.0000	50	46.18	Varies	Complicance

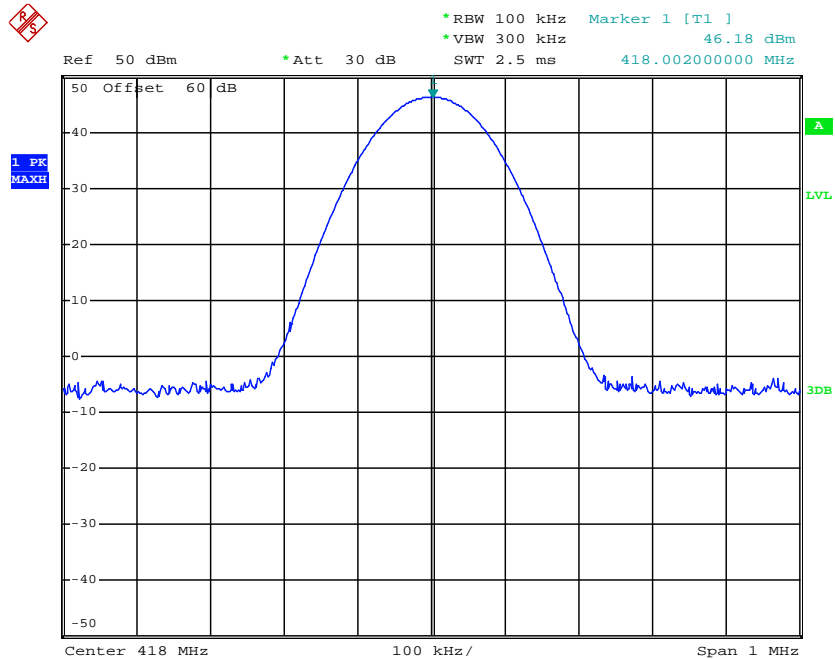

Date: 5.FEB.2013 15:38:59

Modulation Type	Channel Separation	Freq.(MHz)	Rated Power (Watt)	Measurement (dBm)	FCC Limit	Results
FM	12.5 KHz	435.5000	50	47.61	Varies	Complicance

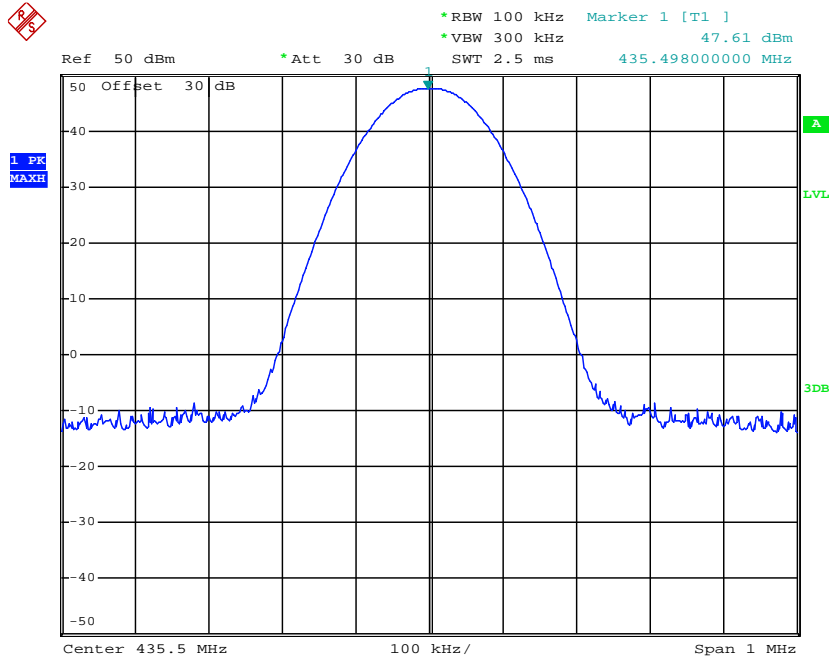

Date: 4.FEB.2013 17:37:59

Modulation Type	Channel Separation	Freq.(MHz)	Rated Power (Watt)	Measurement (dBm)	FCC Limit	Results
FM	12.5 KHz	453.0000	50	47.37	Varies	Complicance

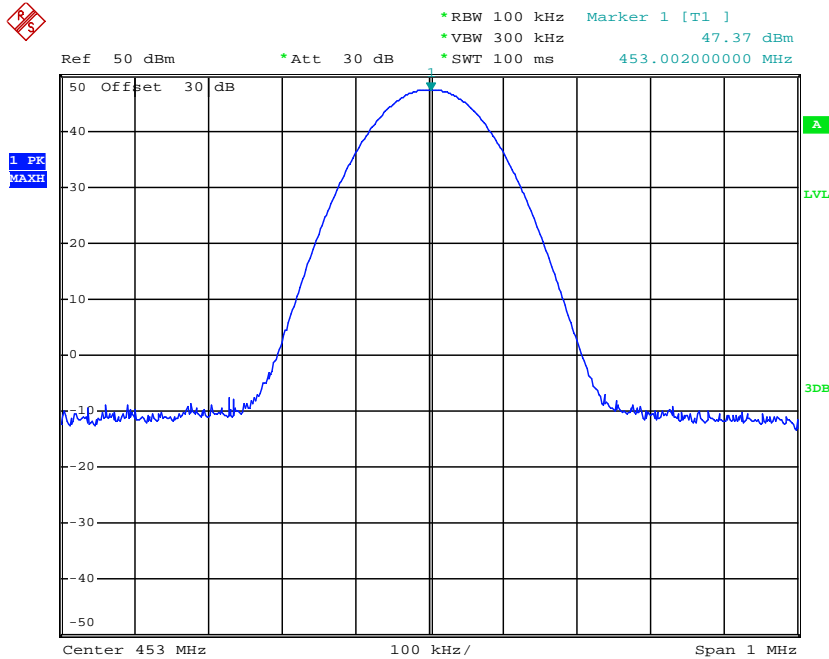

Date: 4.FEB.2013 16:11:41

Modulation Type	Channel Separation	Freq.(MHz)	Rated Power (Watt)	Measurement (dBm)	FCC Limit	Results
FM	12.5 KHz	469.5000	50	46.53	Varies	Complicance

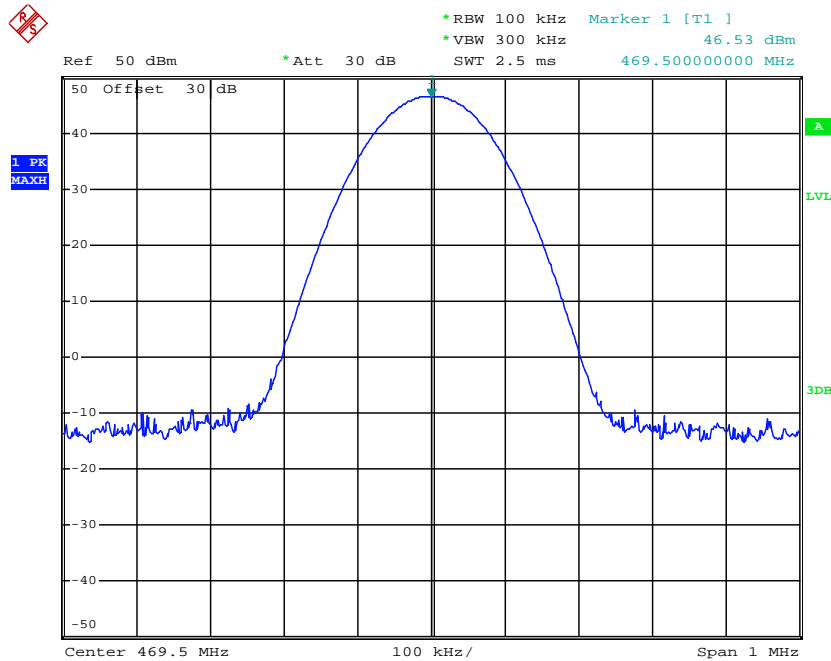

Date: 4.FEB.2013 17:13:58

Modulation Type	Channel Separation	Freq.(MHz)	Rated Power (Watt)	Measurement (dBm)	FCC Limit	Results
4FSK	12.5 KHz	406.5000	50	47.38	Varies	Complicance

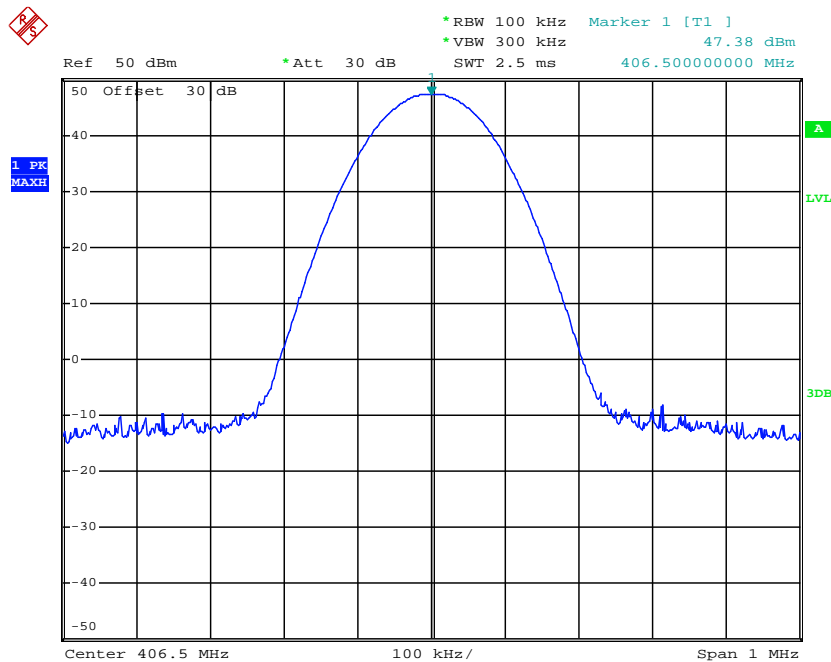

Date: 5.FEB.2013 15:55:02

Modulation Type	Channel Separation	Freq.(MHz)	Rated Power (Watt)	Measurement (dBm)	FCC Limit	Results
4FSK	12.5 KHz	418.0000	50	46.17	Varies	Complicance

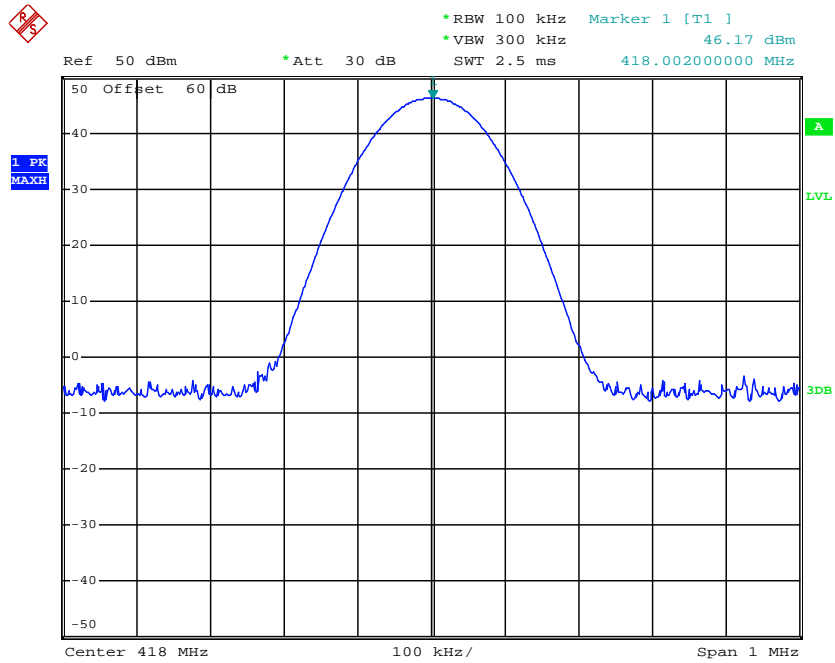

Date: 5.FEB.2013 15:39:47

Modulation Type	Channel Separation	Freq.(MHz)	Rated Power (Watt)	Measurement (dBm)	FCC Limit	Results
4FSK	12.5 KHz	435.5000	50	47.57	Varies	Complicance

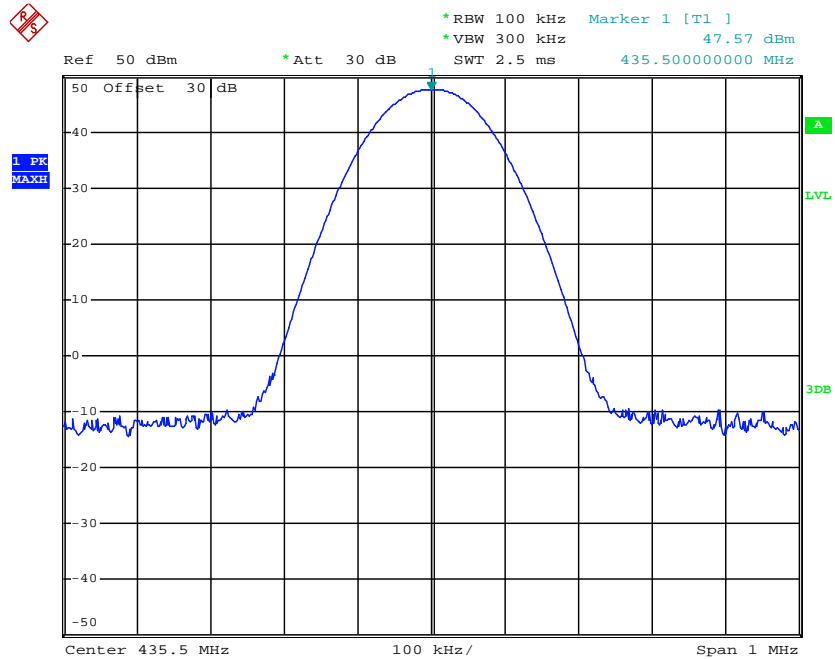

Date: 5.FEB.2013 15:43:38

Modulation Type	Channel Separation	Freq.(MHz)	Rated Power (Watt)	Measurement (dBm)	FCC Limit	Results
4FSK	12.5 KHz	453.0000	50	47.19	Varies	Complicance

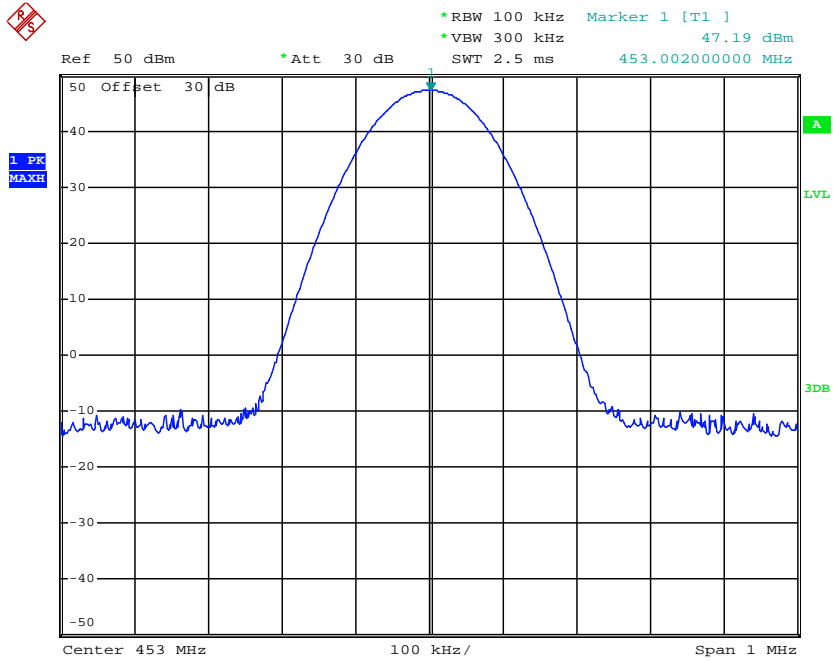

Date: 5.FEB.2013 15:53:00

Modulation Type	Channel Separation	Freq.(MHz)	Rated Power (Watt)	Measurement (dBm)	FCC Limit	Results
4FSK	12.5 KHz	469.5000	50	46.47	Varies	Complicance

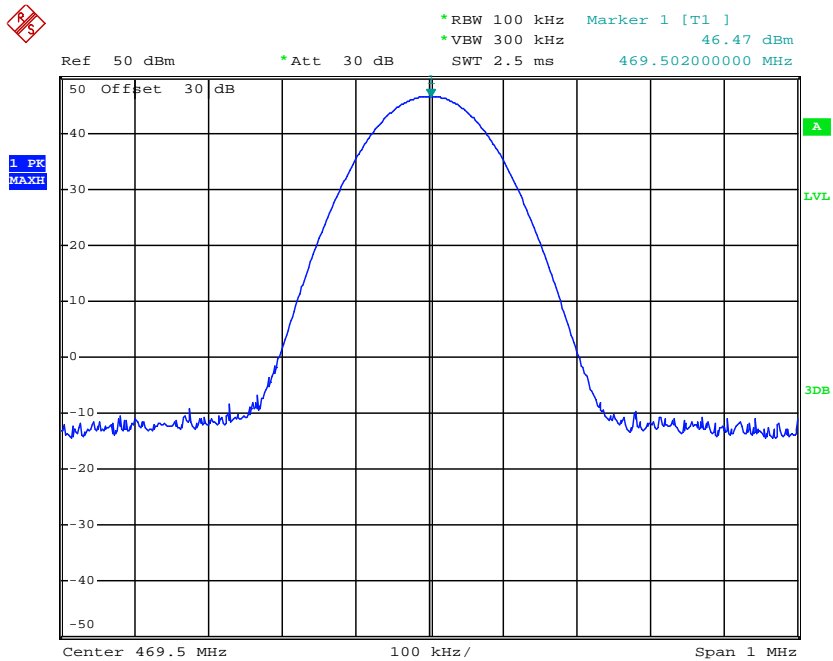

Date: 5.FEB.2013 15:56:26

Modulation Type	Channel Separation	Freq.(MHz)	Rated Power (Watt)	Measurement (dBm)	FCC Limit	Results
FM	12.5 KHz	406.5000	15	39.49	Varies	Complicance

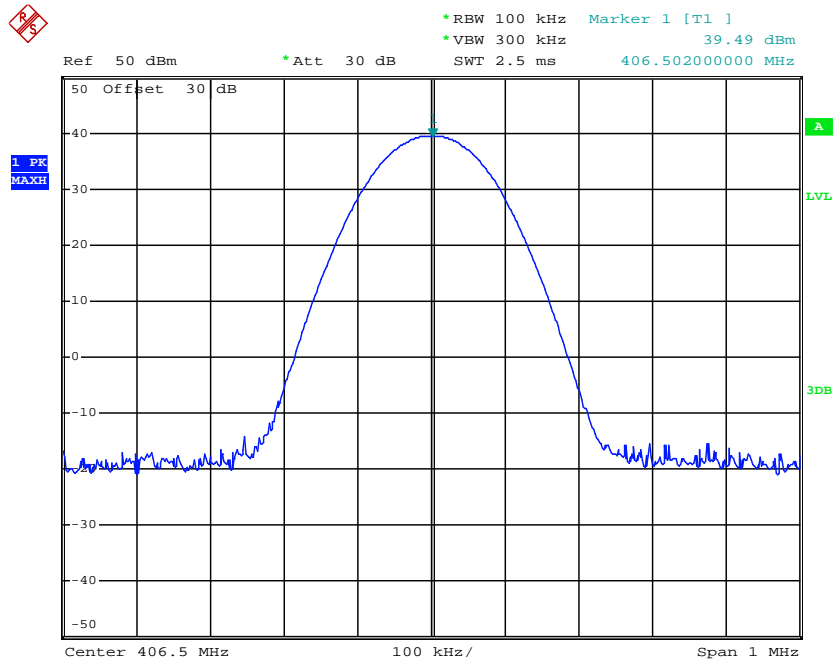

Date: 4.FEB.2013 17:23:37

Modulation Type	Channel Separation	Freq.(MHz)	Rated Power (Watt)	Measurement (dBm)	FCC Limit	Results
FM	12.5 KHz	418.0000	15	41.22	Varies	Complicance

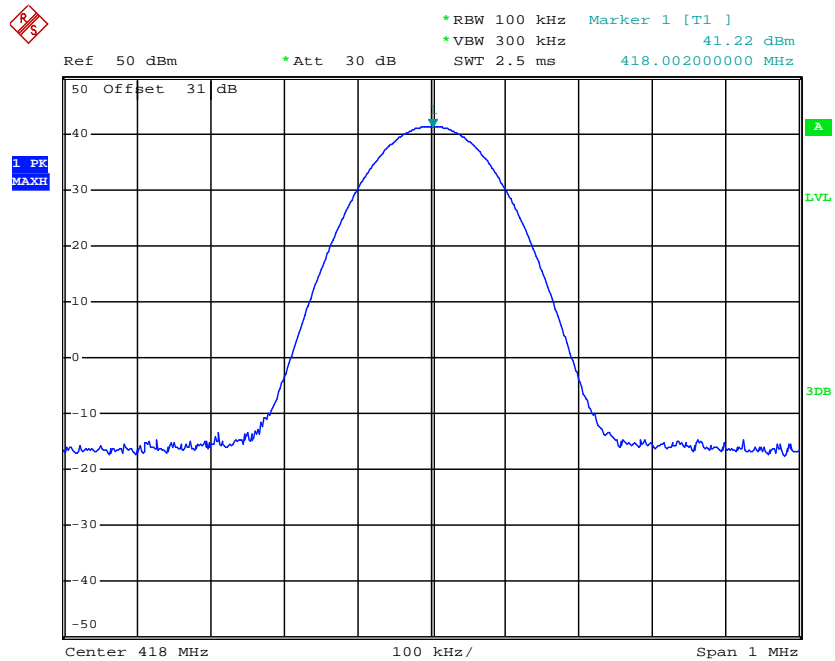

Date: 30.JAN.2013 15:47:49

Modulation Type	Channel Separation	Freq.(MHz)	Rated Power (Watt)	Measurement (dBm)	FCC Limit	Results
FM	12.5 KHz	435.5000	15	43.56	Varies	Complicance

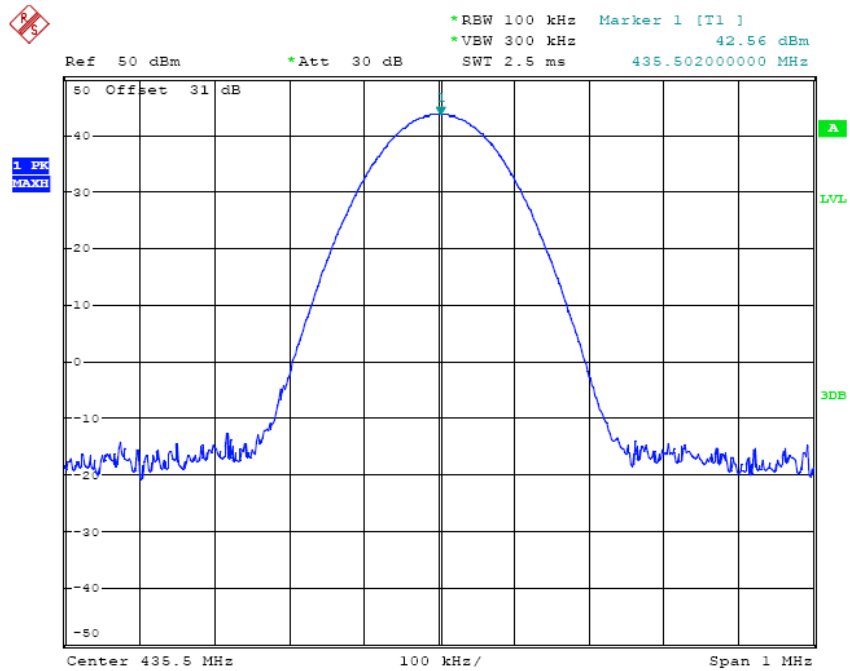

Date: 4.FEB.2013 17:38:25

Modulation Type	Channel Separation	Freq.(MHz)	Rated Power (Watt)	Measurement (dBm)	FCC Limit	Results
FM	12.5 KHz	453.0000	15	41.27	Varies	Complicance

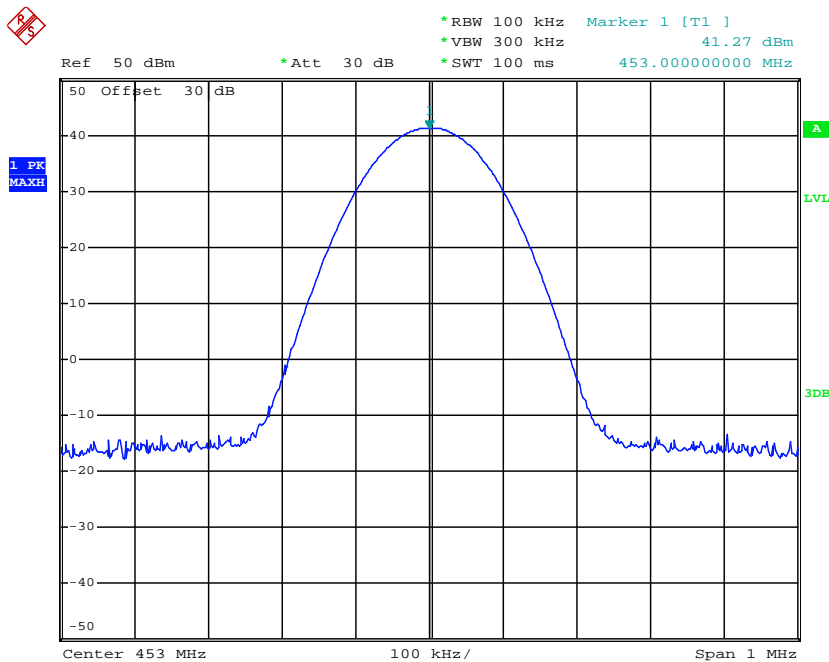

Date: 4.FEB.2013 16:12:28

Modulation Type	Channel Separation	Freq.(MHz)	Rated Power (Watt)	Measurement (dBm)	FCC Limit	Results
FM	12.5 KHz	469.5000	15	40.25	Varies	Complicance

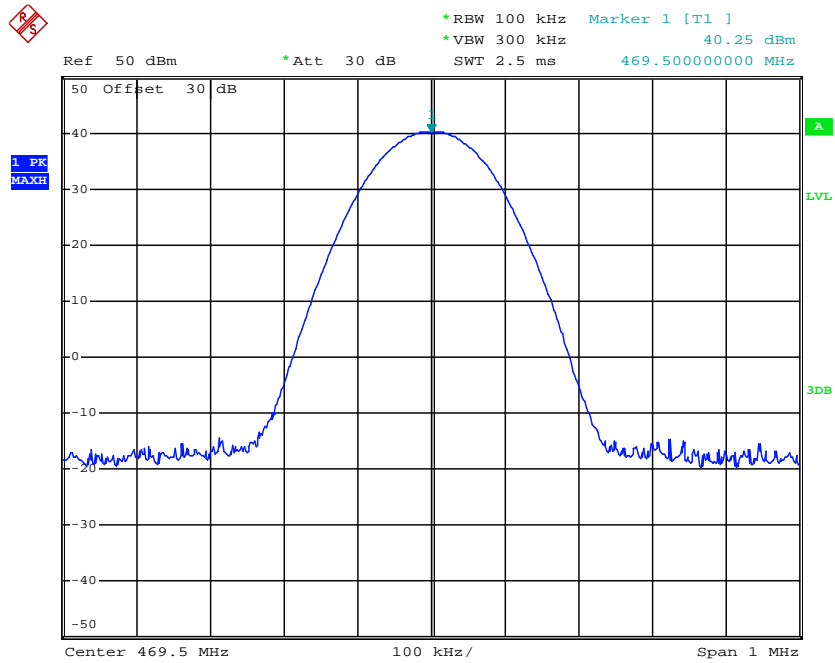

Date: 4.FEB.2013 17:13:21

Modulation Type	Channel Separation	Freq.(MHz)	Rated Power (Watt)	Measurement (dBm)	FCC Limit	Results
4FSK	12.5 KHz	406.5000	15	39.55	Varies	Complicance

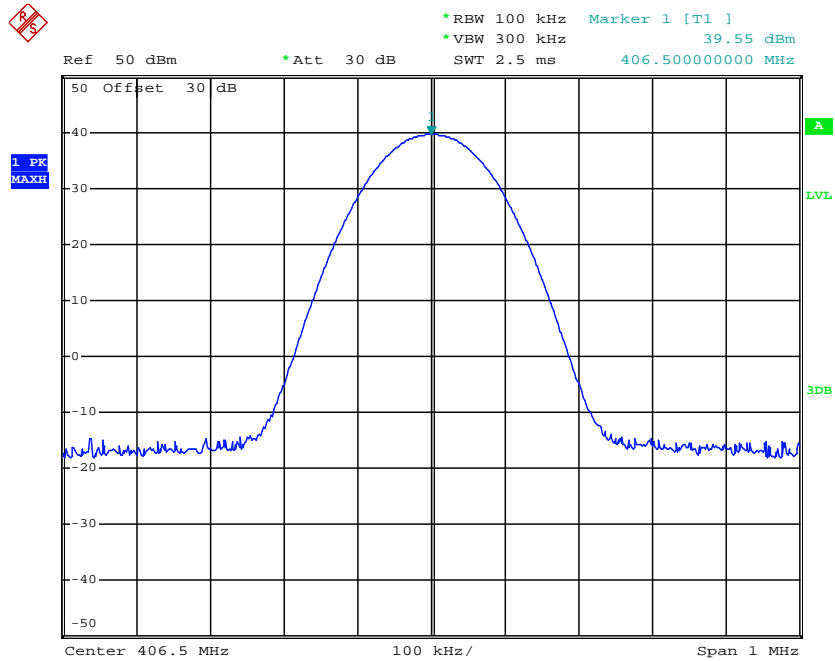

Date: 30.JAN.2013 15:37:09

Modulation Type	Channel Separation	Freq.(MHz)	Rated Power (Watt)	Measurement (dBm)	FCC Limit	Results
4FSK	12.5 KHz	418.0000	15	41.22	Varies	Compliance

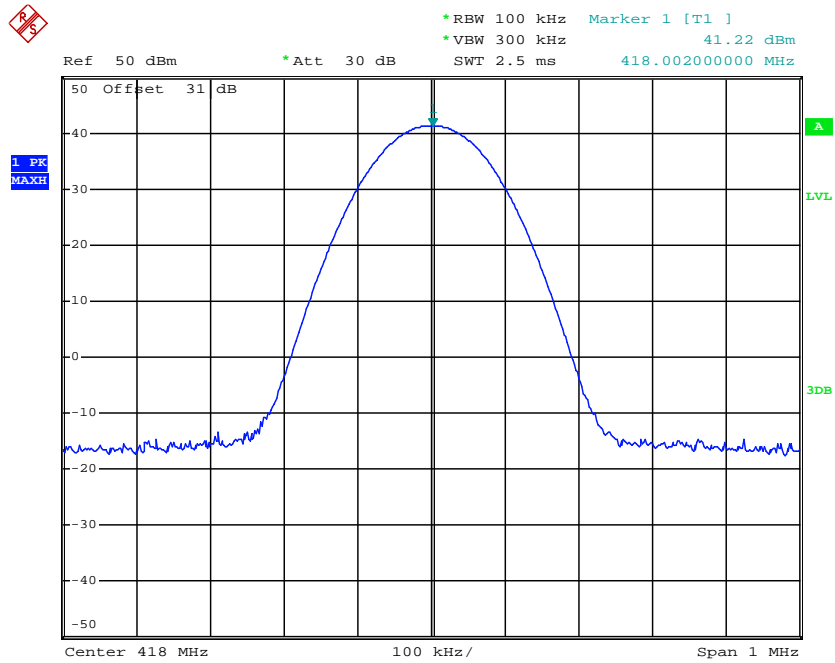

Date: 30.JAN.2013 15:47:49

Modulation Type	Channel Separation	Freq.(MHz)	Rated Power (Watt)	Measurement (dBm)	FCC Limit	Results
4FSK	12.5 KHz	435.5000	15	43.26	Varies	Compliance

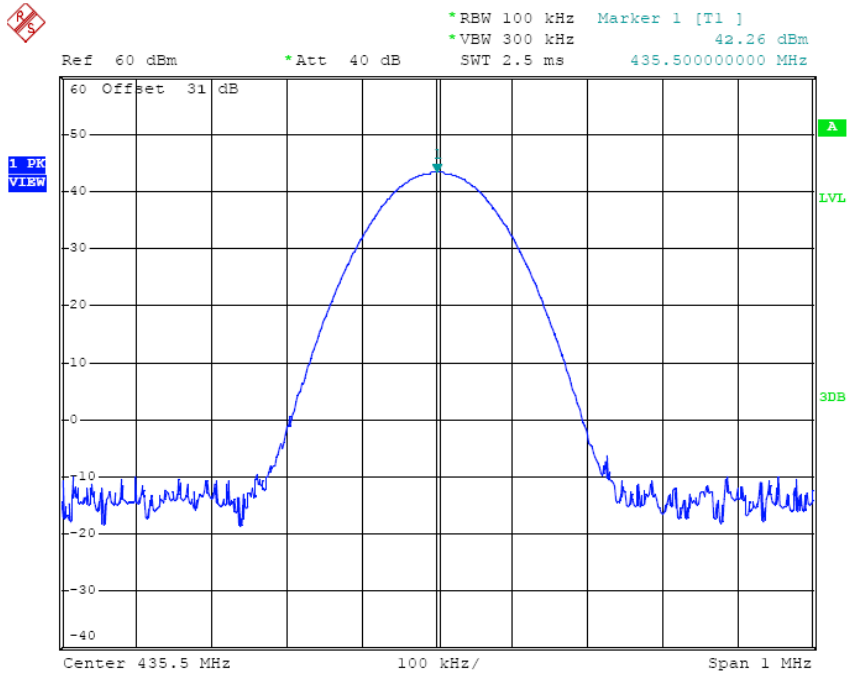

Date: 30.JAN.2013 15:59:08

Modulation Type	Channel Separation	Freq.(MHz)	Rated Power (Watt)	Measurement (dBm)	FCC Limit	Results
4FSK	12.5 KHz	453.0000	15	41.79	Varies	Complicance

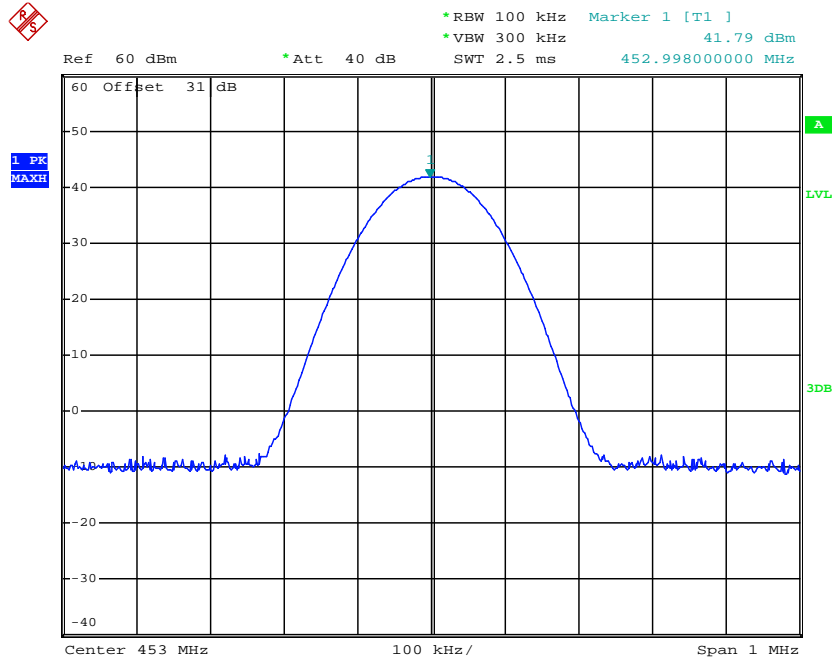

Date: 30.JAN.2013 16:09:28

Modulation Type	Channel Separation	Freq.(MHz)	Rated Power (Watt)	Measurement (dBm)	FCC Limit	Results
4FSK	12.5 KHz	469.5000	15	40.87	Varies	Complicance

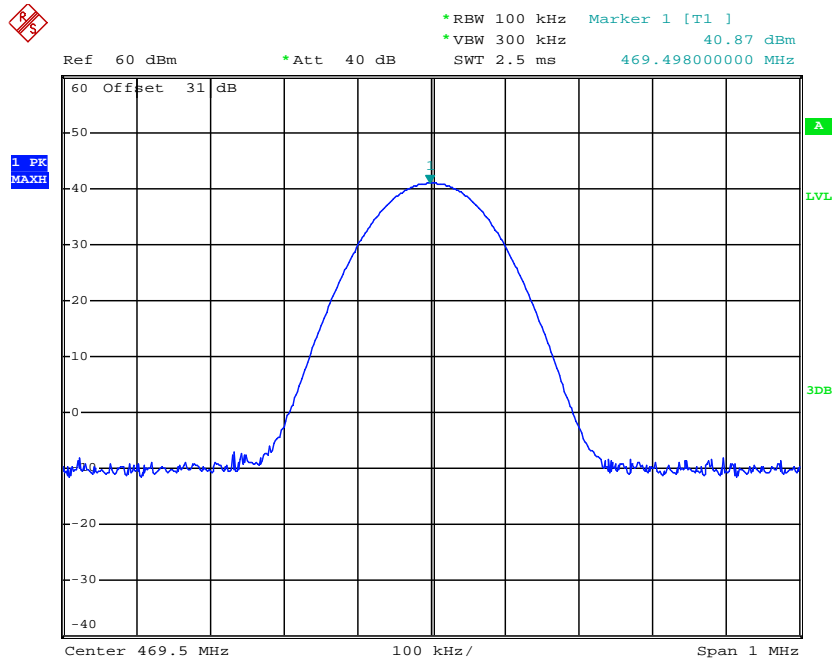

Date: 30.JAN.2013 16:16:55

4.8. Transmitter Frequency Behavior

TEST APPLICABLE

Section 90.214

Transient frequencies must be within the maximum frequency difference limits during the time intervals indicated:

Time intervals ^{1, 2}	Maximum frequency difference ³	All equipment	
		150 to 174 MHz	421 to 512MHz
Transient Frequency Behavior for Equipment Designed to Operate on 25 KHz Channels			
t ₁ ⁴	± 25.0 KHz	5.0 ms	10.0 ms
t ₂	± 12.5 KHz	20.0 ms	25.0 ms
t ₃ ⁴	± 25.0 KHz	5.0 ms	10.0 ms
Transient Frequency Behavior for Equipment Designed to Operate on 12.5 KHz Channels			
t ₁ ⁴	± 12.5 KHz	5.0 ms	10.0 ms
t ₂	± 6.25 KHz	20.0 ms	25.0 ms
t ₃ ⁴	± 12.5 KHz	5.0 ms	10.0 ms
Transient Frequency Behavior for Equipment Designed to Operate on 6.25 KHz Channels			
t ₁ ⁴	±6.25 KHz	5.0 ms	10.0 ms
t ₂	±3.125 KHz	20.0 ms	25.0 ms
t ₃ ⁴	±6.25 KHz	5.0 ms	10.0 ms

- t_{on} is the instant when a 1 KHz test signal is completely suppressed, including any capture time due to phasing.
 t₁ is the time period immediately following t_{on}.
 t₂ is the time period immediately following t₁.
 t₃ is the time period from the instant when the transmitter is turned off until t_{off}.
 t_{off} is the instant when the 1 KHz test signal starts to rise.
- During the time from the end of t₂ to the beginning of t₃, the frequency difference must not exceed the limits specified in § 90.213.
- Difference between the actual transmitter frequency and the assigned transmitter frequency.
- If the transmitter carrier output power rating is 6 watts or less, the frequency difference during this time period may exceed the maximum frequency difference for this time period.

TEST PROCEDURE

TIA/EIA-603 2.2.19

TEST CONFIGURATION

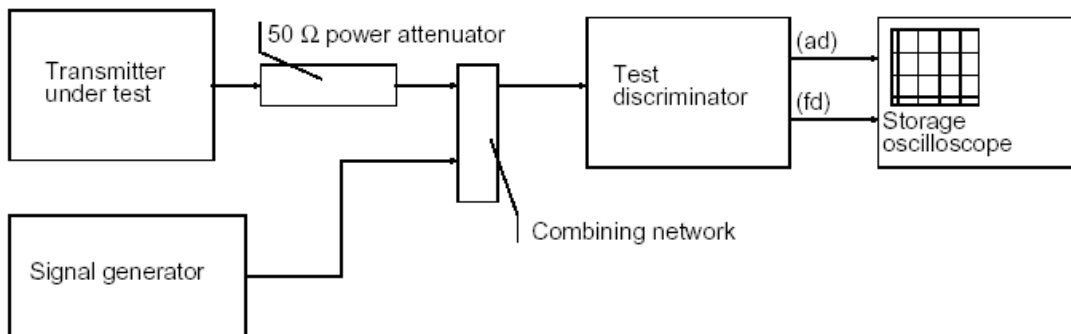

TEST RESULTS

Remark: we test all channels and recorded worst case at middle channel(435.5MHz) for both FM and 4FSK modulation

Please refer to the following plots.

Modulation Type: FM

Transmitter Frequency Behaviour @ 12.5 KHz Channel Separation-----Off - On

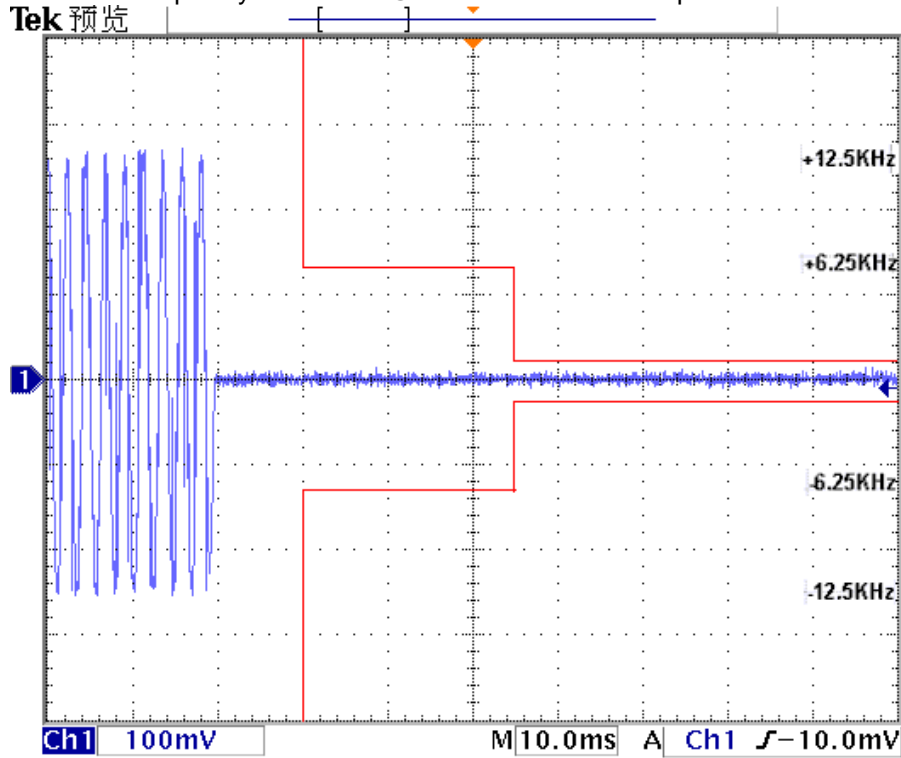

Transmitter Frequency Behaviour @ 12.5 KHz Channel Separation-----On - Off

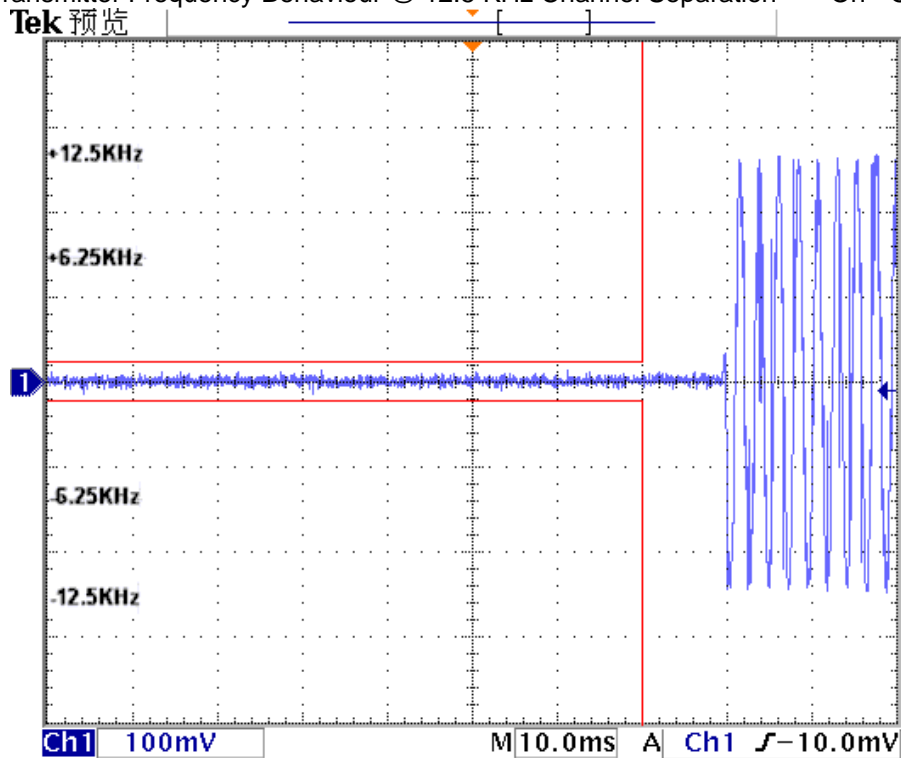

Modulation Type: 4FSK

Transmitter Frequency Behaviour @ 12.5 KHz Channel Separation-----Off – On

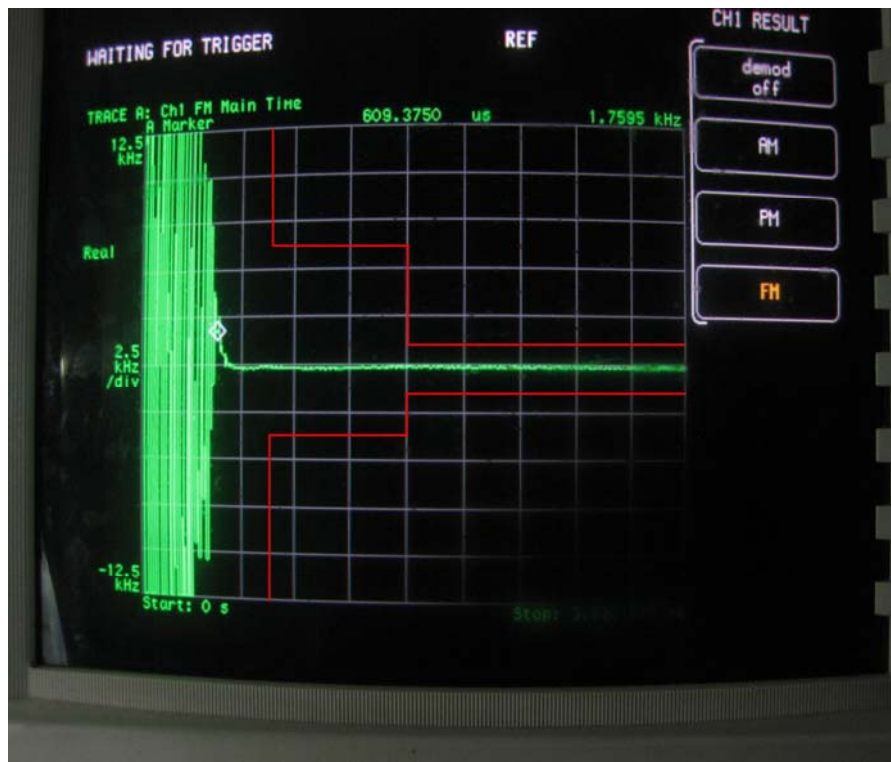

Transmitter Frequency Behaviour @ 12.5 KHz Channel Separation-----On - Off

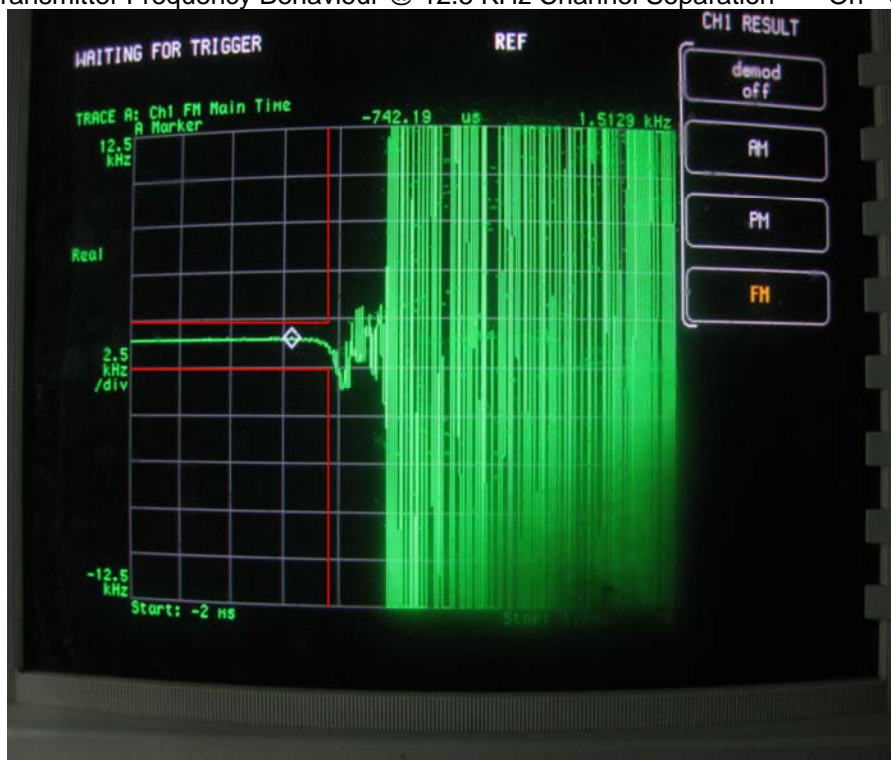

5. Test Setup Photos of the EUT

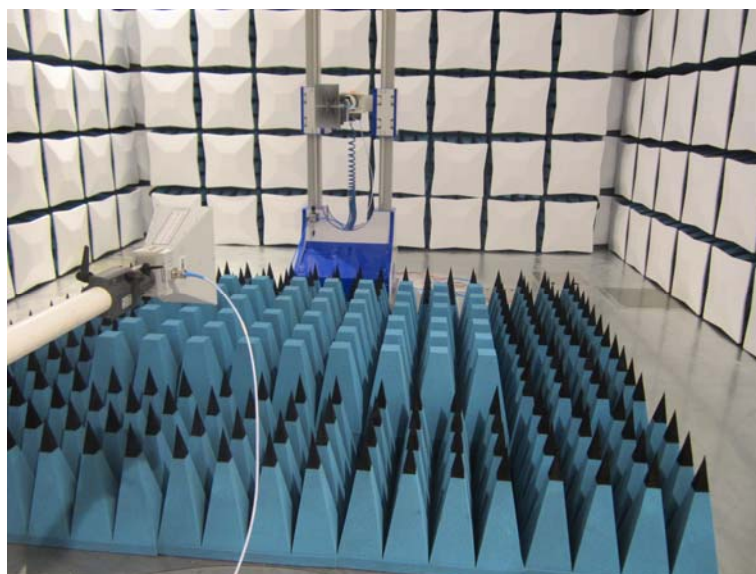

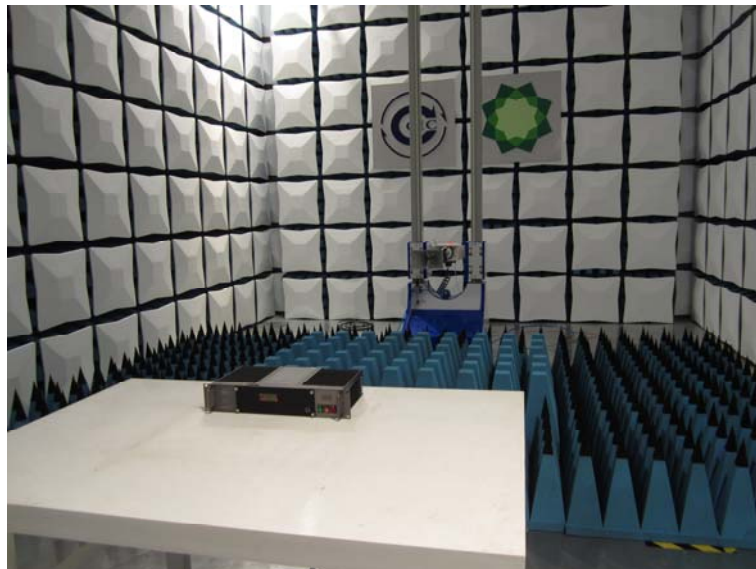

6. External and Internal Photos of the EUT

External photos of the EUT





Internal photos of the EUT



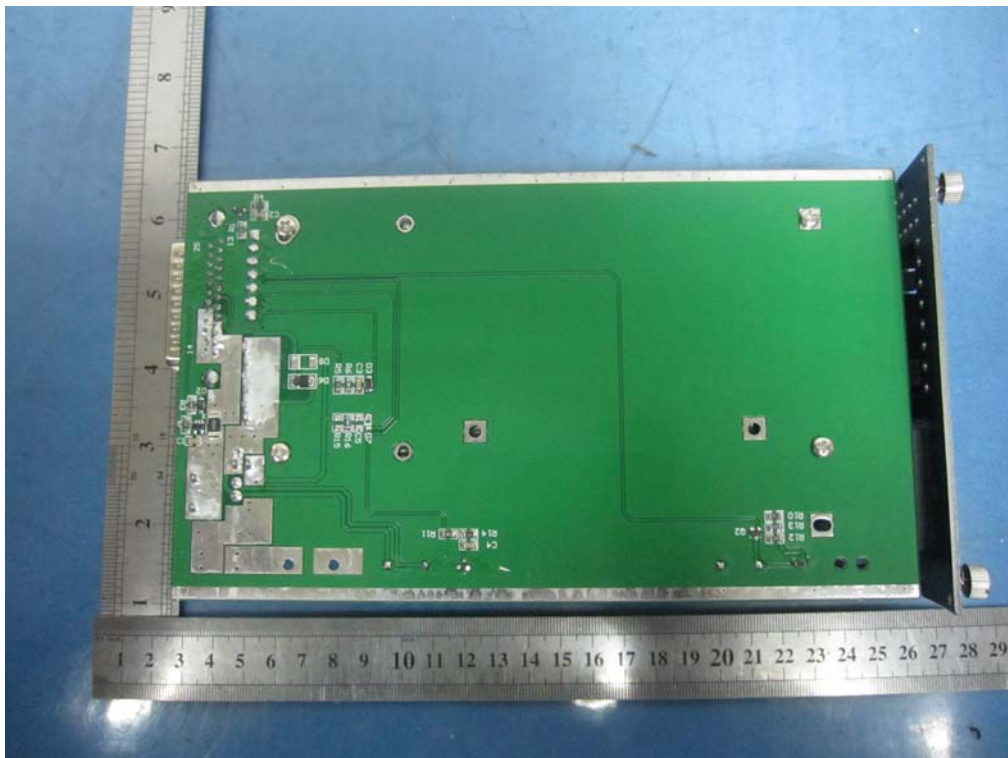
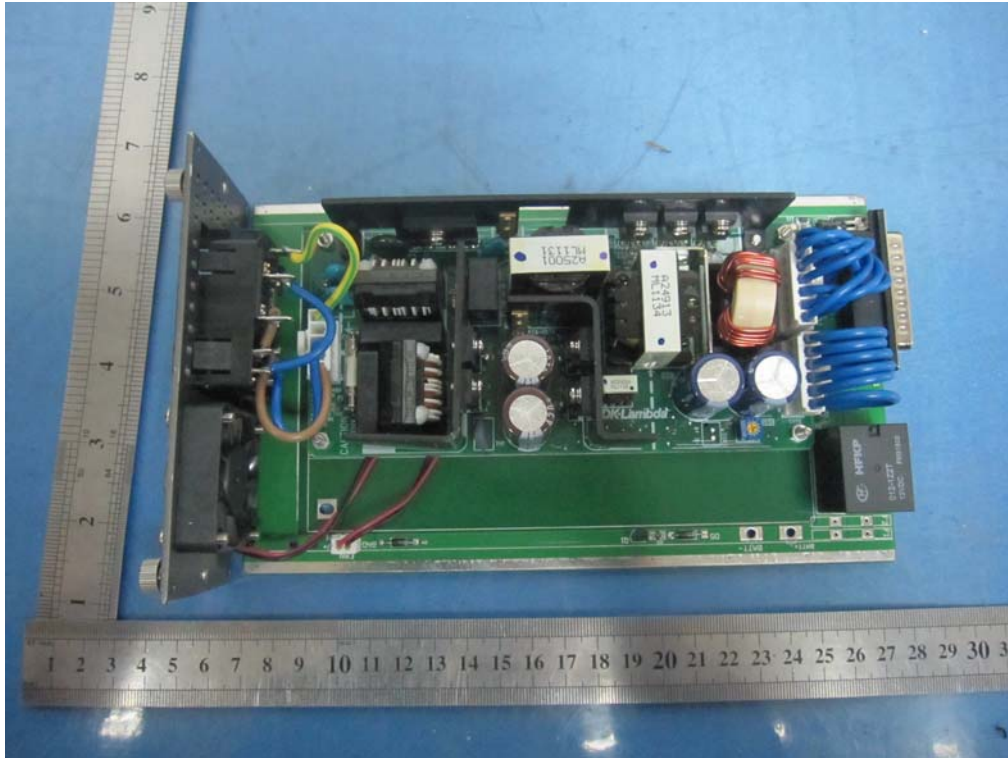

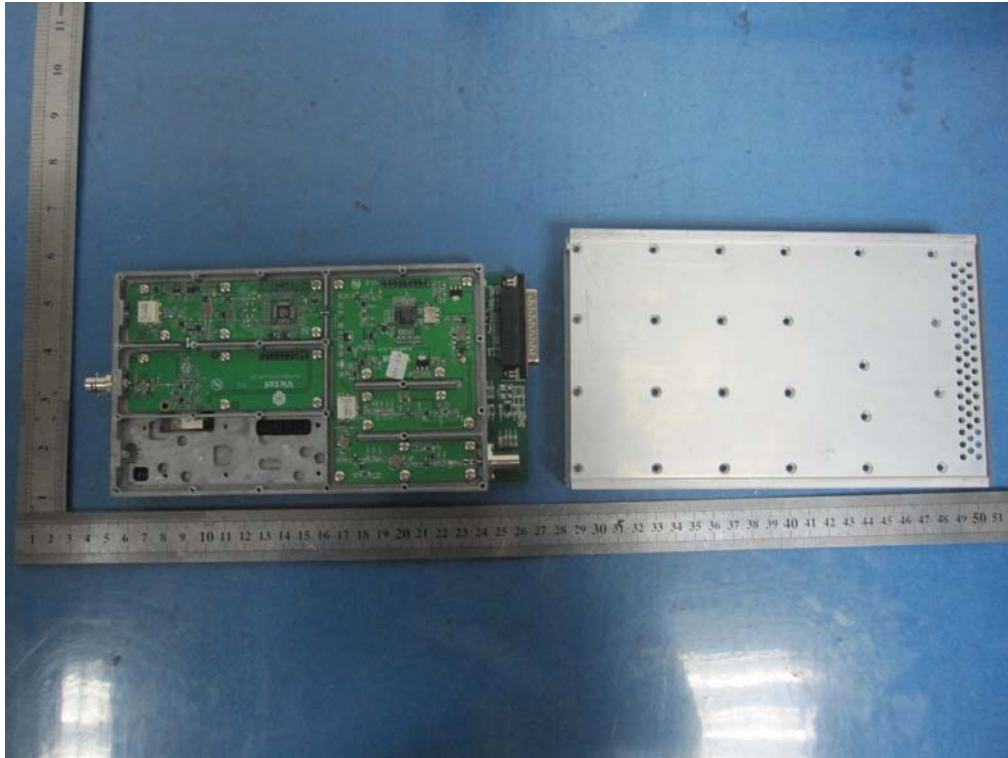





.....End of Report.....