

- Fully Operational Excavator Vehicle
- 6-Function Wireless Remote Control
- Excavator Arm Moves Wirelessly
- Knobby Tires for All-Terrain Action

OPERATE A POWERED EXCAVATOR BY REMOTE CONTROL!



HEAVY DUTY EXCAVATOR

RADIO CONTROLLED CONSTRUCTION VEHICLE

OPERATE A POWERED EXCAVATOR BY REMOTE CONTROL!

AVAILABLE IN TWO FREQUENCIES FOR DUAL OPERATION

- BOX CONTAINS THE FOLLOWING FREQUENCY:
- 27 MHz
 - 49 MHz

BATTERY OPERATED PLAY VEHICLE
AGES 6 AND UP
WARNING! CHOKING HAZARD -
 Small parts. Not suitable for children under 3 years.



AVAILABLE IN TWO FREQUENCIES FOR DUAL OPERATION



HEAVY DUTY EXCAVATOR

RADIO CONTROLLED CONSTRUCTION VEHICLE

FULL FUNCTION WIRELESS REMOTE INCLUDED!



AGES 6+

FULL FUNCTION RC ACTION! EXCAVATOR ARM TILTS UP & DOWN WIRELESSLY



FULL FUNCTION RC ACTION! EXCAVATOR ARM TILTS UP & DOWN WIRELESSLY

- Fully Operational Excavator Vehicle
- 6-Function Wireless Remote Control
- Excavator Arm Moves Wirelessly
- Knobby Tires for All-Terrain Action



BATTERY INSTALLATION

- The excavator requires 3 "AA" batteries (not included). The remote control unit requires two "AA" batteries (not included). When changing batteries, adult supervision is required. Use alkaline batteries for best performance.
- Using a screwdriver, remove the screws from the battery compartment door located on the underside of the vehicle to open (Fig. 1).
 - Insert 3 "AA" batteries while observing the correct polarity.
 - Replace the screw/battery compartment door.
 - Next, remove the screws from the battery compartment door located on the backside of the remote control unit to open (Fig. 2).
 - Insert 2 "AA" batteries while observing the correct polarity.
 - Replace the screw/battery compartment door.
 - Switch the vehicle power switch to the "ON" position (Fig. 3).
 - The excavator is now ready for operation.

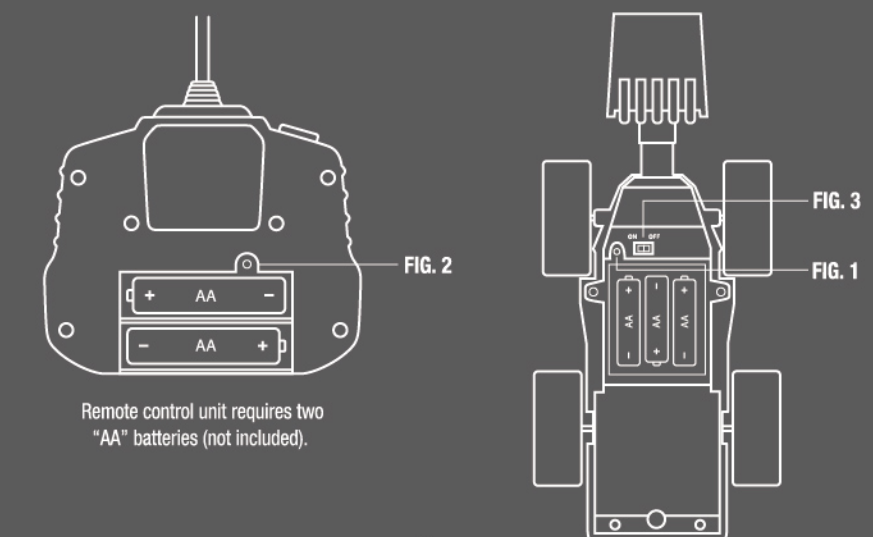

SAFETY PRECAUTIONS

- Do not operate during thunderstorms or rain.
- Avoid water, sand and snow when operating your vehicle.
- Do not submerge vehicle or controller in water.
- Never operate your vehicle on the street or highway.
- Adult supervision is recommended when operating this vehicle.
- Remove all batteries when not in use to avoid accidental operation.
- Never operate your vehicle in a confined or crowded area, and do not use people or animals as obstacles.
- Do not run your vehicle into furniture, objects or hard surfaces, as this will cause damage to both the object and the vehicle.
- Keep fingers, hair and loose clothing away from the tires, gears and motor while the vehicle is switched to "ON".
- Do not leave vehicle or controller near sources of heat or under direct sunlight for long periods of time.
- Do not leave vehicle or controller outside overnight. Dampness is harmful to interior components.

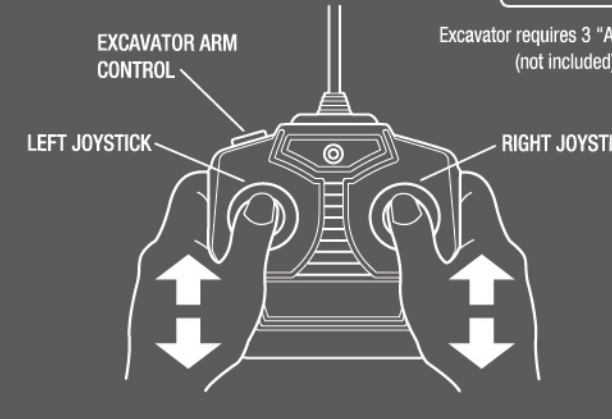

- OPERATING CONTROLS**
- Push both levers up to move forward
 - Push both levers down to move backwards
 - Push left lever to move right
 - Push right lever to move left
 - Press top left button to raise/lower excavator arm

NOTE: This equipment has been tested and found to comply with the limits for a Class B digital device, pursuant to Part 15 of the FCC Rules. These limits are designed to provide reasonable protection against harmful interference in a residential installation. This equipment generates, uses, and can radiate radio frequency energy and, if not installed and used in accordance with the instructions, may cause harmful interference to radio communications.

However, there is no guarantee that interference will not occur in a particular installation. If this equipment does cause harmful interference to radio or television reception, which can be determined by turning the equipment off and on, the user is encouraged to try to correct the interference by one or more of the following measures:

- Reorient or relocate the receiving antenna.
- Increase the separation between the equipment and receiver.
- Connect the equipment into a power outlet on a circuit different from that which the receiver is connected.
- Consult the dealer or an experienced radio/TV technician for help.

This device complies with Part 15 of the FCC Rules. Operation is subject to the following two conditions: (1) This device may not cause harmful interference, and (2) this device must accept any interference received, including interference that may cause undesired operation.

WARNING: Changes or modifications not expressly approved by the party responsible for compliance could void the user's authority to operate the equipment.

BATTERY WARNING:

- Do not mix old and new batteries.
- Do not recharge, operate, charge, or use rechargable (nickel-cadmium) batteries.
- Do not use alkaline, silver-oxide, or zinc-carbon batteries in the remote control.
- Never touch the battery terminals with your fingers or other metal objects.
- Do not use the battery terminals as a screwdriver or other metal tool.
- Do not use the battery terminals as a short circuit.
- Do not use the battery terminals as a ground.
- Do not use the battery terminals as a power source.
- Do not use the battery terminals as a power source.
- Do not use the battery terminals as a power source.

KEEP THIS PACKAGE FOR FUTURE USE AS IT CONTAINS IMPORTANT INFORMATION.

This product and design of this package are protected by US copyright law and may not be reproduced, distributed, displayed, published or sold for any purpose without prior written permission. It is not permitted to buy, sell, or reproduce any trademarks or copyright notice from this package.

2905006 (32229)
HEAVY DUTY EXCAVATOR
 RADIO CONTROLLED CONSTRUCTION VEHICLE
 ©2015 MacGonigal, LLC. Blue Hat Toy Company and all associated logos are trademarks of MacGonigal, LLC. All rights reserved.
 Distributed by MacGonigal, LLC, Irvine, CA 92618.
 For technical support, please call 1-800-231-2141.
 Made in China

TRAY INSERT