



MovingMedia[®] 2000

iCell CDMA2000 1X

iPA 800 MHz

Bi-directional Amplifier

BASIC INSTALLATION GUIDE

**RELEASE 4.5
DRAFT 0.1
PART NUMBER NXX0306XXX**

Copyright © 2004 UTStarcom Incorporated. All rights reserved.

Copyright © 2004, UTStarcom, Inc. All rights reserved. No part of this documentation may be reproduced in any form or by any means or used to make any derivative work (such as translation, transformation, or adaptation) without prior written permission from UTStarcom, Inc.

UTStarcom, Inc. reserves the right to revise this documentation and to make changes in content from time to time without obligation on the part of UTStarcom, Inc. to provide notification of such revision or change.

UTStarcom, Inc. provides this documentation without warranty of any kind, either implied or expressed, including, but not limited to, the implied warranties of merchantability and fitness for a particular purpose. UTStarcom may make improvements or changes in the product(s) and/or the program(s) described in this documentation at any time.

UNITED STATES GOVERNMENT LEGENDS:

If you are a United States government agency, then this documentation and the software described herein are provided to you subject to the following:

United States Government Legend: All technical data and computer software is commercial in nature and developed solely at private expense. Software is delivered as Commercial Computer Software as defined in DFARS 252.227-7014 (June 1995) or as a commercial item as defined in FAR 2.101(a) and as such is provided with only such rights as are provided in UTStarcom's standard commercial license for the Software. Technical data is provided with limited rights only as provided in DFAR 252.227-7015 (November 1995) or FAR 52.227-14 (June 1987), whichever is applicable. You agree not to remove or deface any portion of any legend provided on any licensed program or documentation contained in, or delivered to you in conjunction with, this User Guide.

UTStarcom, the UTStarcom logo and MovingMedia 2000 are registered trademarks of UTStarcom, Inc. and its subsidiaries. Other brand and product names may be registered trademarks or trademarks of their respective holders.

Regulatory

This device complies with Part 15 of the FCC Rules. Operation of this device is subject to the following two conditions: (1) this device may not cause harmful interference, and (2) this device must accept any interference received including interference that may cause undesired operation.

Where appropriate, the use of the equipment is subject to the following conditions:

CAUTION! Unauthorized modifications or changes not expressly approved by UTStarcom could void compliance with regulatory rules, and thereby your authority to use this equipment.

WARNING (EMI) - United States FCC Information - This equipment has been tested and found to comply with the limits pursuant to Part 15 of the FCC Rules. These limits are designed to provide reasonable protection against harmful interference in an appropriate installation. This equipment generates, uses, and can radiate radio frequency energy and, if not installed and used in accordance with the instructions, may cause harmful interference to radio communication. However, there is no guarantee that interference will not occur in a particular installation. If this equipment does cause harmful interference to radio or television reception, which can be determined by turning the equipment OFF and ON, the user is encouraged to try to correct the interference by one or more of the following measures:

- Reorient or relocate the receiving antenna.
- Increase the separation between the equipment and receiver.
- Connect the equipment into an outlet on a circuit different from that to which the receiver is connected.
- Consult the dealer or an experienced radio/TV technician

To comply with Maximum Permissible Exposure (MPE) requirements, the maximum composite output from the antenna cannot exceed ____ Watts EIRP and the antenna must be permanently installed in a fixed location that provides at least ____ cm of separation from all persons.

1 PREFACE

1.1 Objective

This document provides installation and configuration instructions for setting up an iCell-CDMA2000 1X iPA system. It covers physical installation only.

1.2 Organization

The major sections of this guide are as follows:

Table 1-1: Organization Table

Chapter	Title	Description
Chapter 1	Preface	Introduction to the Installation Guide.
Chapter 2	iCell System Description	Describes the System components
Chapter 3	iPA Physical Installation	Provides mechanical installation and wiring instructions.

1.3 Reference Documents

The following table summarizes the applicable reference documents.

Table 1-2: Reference Documents

Ref.	Title	Number
1	User Manual Pico BTS	
2	iCell CDMA2000 1X Alarms and Statistics	
3	iCell CDMA2000 1X Configuration Guide	

1.4 Acronyms and Abbreviations

The following table summarizes the acronyms and abbreviations used throughout the document.

Table 1 -3: Acronyms and Abbreviations

1PPS	One Pulse Per Second
AAA	Authentication, Authorization, and Accounting function
Abis	Protocol interface between sBSC and BTS
ASN.1	The language used to define the MIB of the NE
EM	Element Manager
GPS	Global Positioning System
HLR	Home Location Register
sBSC	iCell Base Station Controller
BTS	iCell Base Station Transceiver Subsystem
BSS	Base Station Subsystem (BSC+BTS)
iMB	iCell Main Board
IOS	Inter-Operability Standard; A-Interface between sBSC and MSC
IP	Internet Protocol
iPA	iCell Power Amplifier
MIB	Management Information Base
MS	Mobile Station (phone)
MSC	Mobile Switching Center
NE	Network Element or agent
NOC	Network Operations Center
OID	Object Identifier
OMC	Operations & Maintenance Center
PA	Power Amplifier

PDSN	Packet Data Serving Node
PSTN	Public Switch Telephone Network
RF	Radio Frequency
SMSC	Short Message Service Center
SNMP	Simple Network Management Protocol
SNTP	Simple Network Timing Protocol To Be Defined
TBD	Transmission Control Protocol
TCP	Time Of Day
TOD	

2 iCell MACRO SYSTEM DESCRIPTION

This chapter provides an iCell system description.

2.1 Introduction

The iCell is an IP-based solution for CDMA2000 1X radio access networks. The iCell system provides the overall functionality of a CDMA2000 1X Base station transceiver subsystem (BTS) and soft base station controller (sBSC), providing an IP over Ethernet interface to the core network. For Macro coverage small footprint iPA Bi-directional amplifier is added to the basic BTS configuration. Figure 2-1 shows the system architecture.

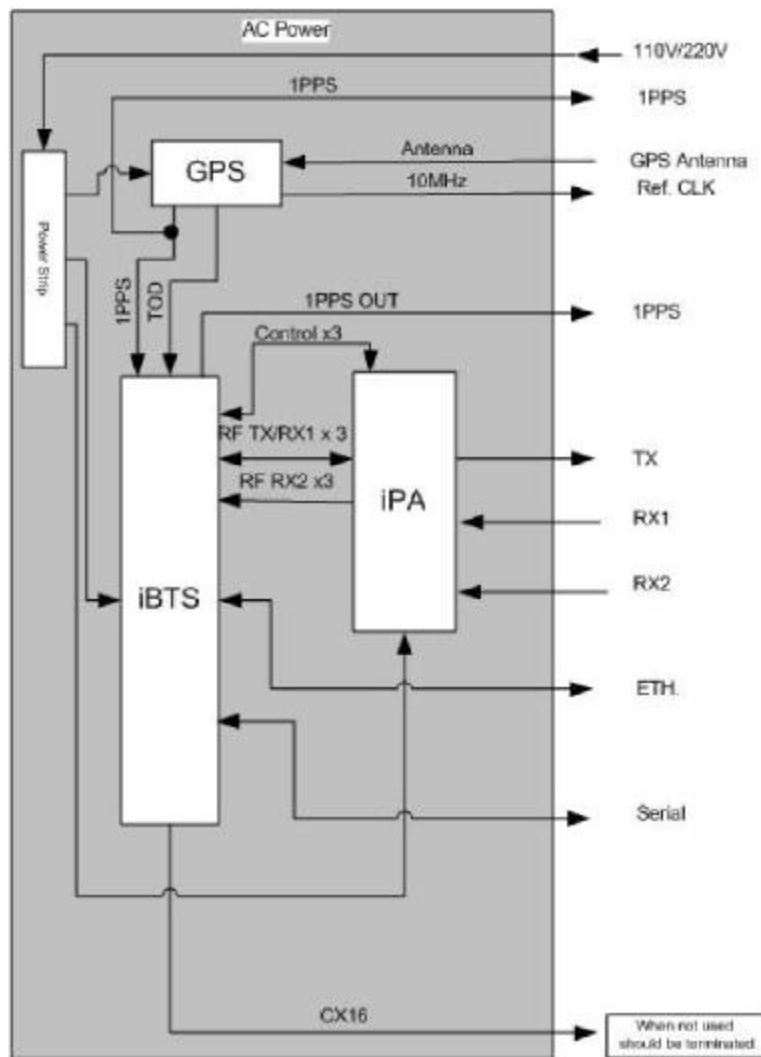

Figure 2-1: iCell Macro BSS using iPA

3 BTS PHYSICAL INSTALLATION

3.1 General

This chapter provides physical installation and wiring instructions for the iPA.

3.2 Unpacking

Upon receipt of, and before opening the iCell packages, inspect for any damage that might have occurred during shipping. If the package shows any signs of external damage or rough handling, notify your carrier's representative.



CAUTION

All modules are susceptible to electrostatic discharge (ESD) even while installed. Take the necessary precautions to minimize electrostatic damage while handling modules.

Carefully remove all parts and hardware out of the packages. Carry out a full inventory before installation procedure starts.

3.3.1 BTS 19" Rack Mount

See Figure 3-1 and Figure 3-2.

1. Insert the BTS 1X 19" unit into a 19" rack. Secure with four NF10 screws.
2. Connect BTS 19" Rack Mount according to paragraph 3.4.2.



Figure 3-1: BTS 19" Rack Mount Rear View



Figure 3.2: BTS 19" Rack Mount Front View



Figure 3.3: iPA Front View



Figure 3.4: iPA Rear View (AC input Power) (-48v DC version also available)

3.4 Interface Connections

3.4.1 BTS and iPA Interface Connections

Verify that the power switch is off on both the iPA and the BTS unit

3.4.2 BTS to iPA Interface Connection

Figure 3-1 illustrates the wiring diagram of the BTS and iPA for Macro coverage. Table 3-1 provides the wiring parameters.

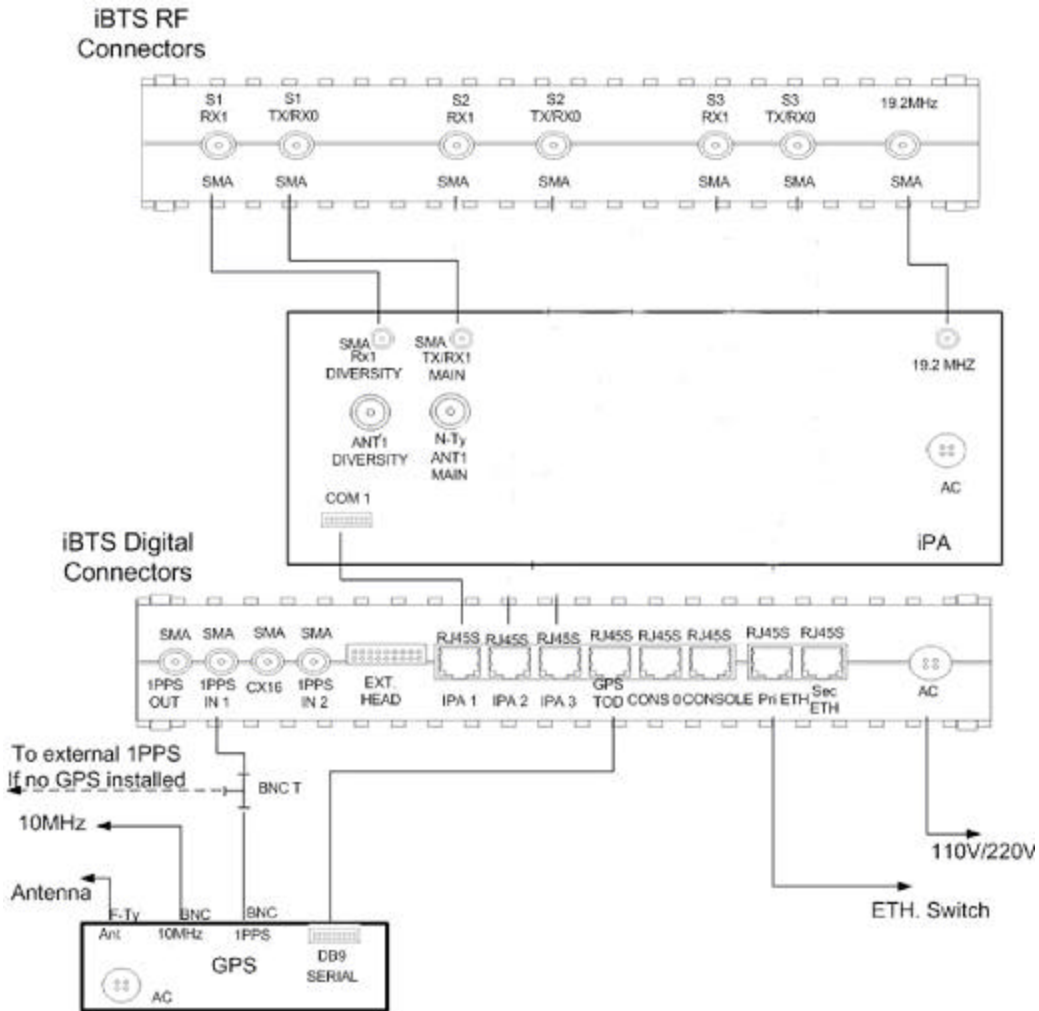

Figure 3.1: BTS and iPA wiring diagram

Table 3-1: iBTS 19" Wiring

iBTS		Cable MCN	Destination	
Name	Type		Name	Type
S3 RX1	SMA	45-89330-M3	iPA RX3 Diversity	SMA
S3 TX/RX0	SMA	45-89330-M3	iPA TX/RX3 Diversity	SMA
S2RX2	SMA	45-89330-M3	iPA RX2Diversity	SMA
S2 TX/RX0	SMA	45-89330-M3	iPA TX/RX2 Diversity	SMA
S1 RX2	SMA	45-89330-M3	iPA RX1 Diversity	SMA
S1 TX/RX0	SMA	45-89330-M3	iPA TX/RX1 Diversity	SMA
iPA 1	RJ45S	45-89331-M2	iPA Com 1	DB-9
iPA 2	RJ45S	45-89331-M2	iPA Com 2	DB-9
iPA 3	RJ45S	45-89331-M2	iPA Com 3	DB-9
19.2 MHz	SMA	45-89330-M3	iPA SMA	19.2 MHz
Pri Eth	RJ45S	Standard CAT5	Ethernet Switch	RJ45
Console	RJ45S	45-89331-M2	PC	DB9
GPS TOD	RJ45S	45-89332-M3	GPS DB9 Serial	DB9
1 PPS IN 1	SMA		GPS 1 PPS	BNC
AC Power	Power Supply Switching	363-06097-0015 or 363-02155-0002	External Source Power	

NOTE

All SMA connectors that are not connected should be terminated.

3.4.2.1 Connecting to iPA for three sector case:

To Connect the iBTS to the iPA:

Connect the iBTS iPA 1 RJ-45 connector to the iPA COM 1 DB-9 connector with cable MCN 45-89330-M3.

Connect the iBTS iPA 2 RJ-45 connector to the iPA COM 2 DB-9 connector with cable MCN 45-89330-M3.

Connect the iBTS iPA 3 RJ-45 connector to the iPA COM 3 DB-9 connector with cable MCN 45-89330-M3.

Connect the iBTS S1 RX1 SMA Connector to the iPA RX1 Diversity SMA connector with cable MCN 45-89331-M2.

Connect the iBTS S1 TX/RX0 SMA Connector to the iPA TX/RX1 SMA connector with cable MCN 45-89331-M2.

Connect the iBTS S2 RX1 SMA Connector to the iPA RX2 Diversity SMA connector with cable MCN 45-89331-M2.

Connect the iBTS S2 TX/RX0 SMA Connector to the iPA TX/RX2 SMA connector with cable MCN 45-89331-M2.

Connect the iBTS S3 RX1 SMA Connector to the iPA RX3 Diversity SMA connector with cable MCN 45-89331-M2.

Connect the iBTS S3 TX/RX0 SMA Connector to the iPA TX/RX3 SMA connector with cable MCN 45-89331-M2.

Connect the iBTS 19.2 MHz SMA connector to iPA 19.2 MHz SMA Connector with cable MCN 45-89331-M2.

3.4.2.2 Miscellaneous Connections for both iPA and BTS units

To connect the remainder connections:

- For AC Rack mount version, just connect the AC cord to 110 or 220 V AC supply.
- For DC Rack Mount version, make sure the main rack breaker is off and the BTS power switch is in the off position. Connect the -48v wire as indicated on the rear of the unit marked “-” or “-48v” and the positive (Bat. Rtn) wire to the terminal marked “+” or Bat Return.

The BTS and iPA are now ready for configuration. Refer to *iCell CDMA2000 1X Configuration Guide*.