

Radio Test Report

*FCC Part 22 and RSS 129 Issue 2
(869.76 MHz to 893.25 MHz)*

iCell COMPAC 1X IP – RAN 800MHz CPU DC

COMPANY: Star Solutions
4600 Jacombs Road, Suite 120
Richmond, BC V6V 3B1

TEST SITE(S): Elliott Laboratories
41039 Boyce Road.
Fremont, CA. 94538-2435

REPORT DATE: May 24, 2012

FINAL TEST DATES: April 3, 4, 6 and 9, 2012

TOTAL NUMBER OF PAGES: 42

PROGRAM MGR /
TECHNICAL REVIEWER:



Deniz Demirci
Senior Wireless / EMC Engineer

QUALITY ASSURANCE DELEGATE /
FINAL REPORT PREPARER:

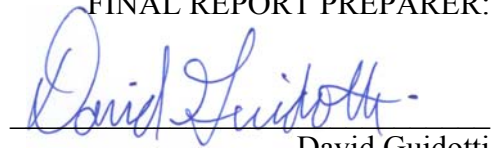

David Guidotti
Senior Technical Writer



Elliott Laboratories is accredited by the A2LA, certificate number 0214.26, to perform the test(s) listed in this report, except where noted otherwise. This report and the information contained herein represent the results of testing test articles identified and selected by the client performed to specifications and/or procedures selected by the client. National Technical Systems (NTS) makes no representations, expressed or implied, that such testing is adequate (or inadequate) to demonstrate efficiency, performance, reliability, or any other characteristic of the articles being tested, or similar products. This report should not be relied upon as an endorsement or certification by NTS of the equipment tested, nor does it represent any statement whatsoever as to its merchantability or fitness of the test article, or similar products, for a particular purpose. This report shall not be reproduced except in full

REVISION HISTORY

Rev#	Date	Comments	Modified By
1	05-24-2012	First release	

TABLE OF CONTENTS

REVISION HISTORY	2
TABLE OF CONTENTS	3
SCOPE.....	4
OBJECTIVE	5
STATEMENT OF COMPLIANCE.....	5
DEVIATIONS FROM THE STANDARDS.....	5
TEST RESULTS.....	6
FCC PART 22 AND RSS 129 ISSUE 2	6
EXTREME CONDITIONS	7
MEASUREMENT UNCERTAINTIES.....	7
EQUIPMENT UNDER TEST (EUT) DETAILS.....	8
GENERAL.....	8
OTHER EUT DETAILS.....	8
ENCLOSURE.....	8
MODIFICATIONS.....	8
SUPPORT EQUIPMENT.....	8
EUT INTERFACE PORTS	9
EUT OPERATION	9
TESTING	10
GENERAL INFORMATION.....	10
RF PORT MEASUREMENT PROCEDURES	11
OUTPUT POWER.....	11
BANDWIDTH MEASUREMENTS	12
CONDUCTED SPURIOUS EMISSIONS.....	12
TRANSMITTER MASK MEASUREMENTS.....	13
FREQUENCY STABILITY.....	13
TRANSIENT FREQUENCY BEHAVIOR:.....	13
RADIATED EMISSIONS MEASUREMENTS.....	14
INSTRUMENTATION	15
FILTERS/ATTENUATORS	15
ANTENNAS.....	15
ANTENNA MAST AND EQUIPMENT TURNTABLE.....	15
SAMPLE CALCULATIONS	16
SAMPLE CALCULATIONS - CONDUCTED SPURIOUS EMISSIONS	16
SAMPLE CALCULATIONS –RADIATED FIELD STRENGTH.....	16
SAMPLE CALCULATIONS –RADIATED POWER.....	17
RECEIVER RADIATED SPURIOUS EMISSIONS SPECIFICATION LIMITS	18
APPENDIX A TEST EQUIPMENT CALIBRATION DATA	19
APPENDIX B TEST DATA	20
END OF REPORT	42

SCOPE

Tests have been performed on the Star Solutions iCell COMPAC 1X IP – RAN 800MHz CPU DC, pursuant to the relevant requirements of the following standard(s) in order to obtain device certification against the regulatory requirements of the Federal Communications Commission and Industry Canada.

- Code of Federal Regulations (CFR) Title 47 Part 2
- Industry Canada RSS-Gen Issue 3
- CFR 47 Part 22
- RSS-129 Issue 2, Rev. 1 September 25, 1999 800 MHz Dual-Mode CDMA Cellular Telephones

Conducted and radiated emissions data has been collected, reduced, and analyzed within this report in accordance with measurement guidelines set forth in the following reference standards and as outlined in Elliott Laboratories test procedures:

ANSI C63.4:2003

ANSI TIA-603-C August 17, 2004

FCC Public Notice, DA-02-1097, May 10, 2002 *Guidance on Certification of Linear Power Amplifiers used with Cellular and PCS Transmitters*

The intentional radiator above has been tested in a simulated typical installation to demonstrate compliance with the relevant Industry Canada performance and procedural standards.

Every practical effort was made to perform an impartial test using appropriate test equipment of known calibration. All pertinent factors have been applied to reach the determination of compliance.

The test results recorded herein are based on a single type test of the Star Solutions iCell COMPAC 1X IP – RAN 800MHz CPU DC and therefore apply only to the tested sample. The sample was selected and prepared by Azadeh Farzin of Star Solutions.

OBJECTIVE

The primary objective of the manufacturer is compliance with the regulations outlined in the previous section.

Prior to marketing in the USA, the device requires certification. Prior to marketing in Canada, Class I transmitters, receivers and transceivers require certification.

Certification is a procedure where the manufacturer submits test data and technical information to a certification body and receives a certificate or grant of equipment authorization upon successful completion of the certification body's review of the submitted documents. Once the equipment authorization has been obtained, the label indicating compliance must be attached to all identical units, which are subsequently manufactured.

Maintenance of compliance is the responsibility of the manufacturer. Any modification of the product which may result in increased emissions should be checked to ensure compliance has been maintained (i.e., printed circuit board layout changes, different line filter, different power supply, harnessing or I/O cable changes, etc.).

Testing was performed only on iCell COMPAC 1X IP – RAN 800MHz CPU DC. This model was considered representative of the following models;

- iCell COMPAC 1X IP – RAN 800MHz CPU DC M/N: CX8011.0
- iCell COMPAC 1X IP – RAN 800MHz DC M/N: CX8010.0

STATEMENT OF COMPLIANCE

The tested sample of Star Solutions iCell COMPAC 1X IP – RAN 800MHz CPU DC complied with the requirements of the standards and frequency bands declared in the scope of this test report.

Maintenance of compliance is the responsibility of the manufacturer. Any modifications to the product should be assessed to determine their potential impact on the compliance status of the device with respect to the standards detailed in this test report.

DEVIATIONS FROM THE STANDARDS

No deviations were made from the published requirements listed in the scope of this report.

TEST RESULTS**FCC Part 22 and RSS 129 Issue 2**

FCC	Canada	Description	Measured	Limit	Result
Transmitter Modulation, output power and other characteristics					
§2.1033 (c) (5)	RSP 100 7.2 (a) RSS 129 Table 5.1	Frequency range(s)	869.76 MHz – 893.25 MHz	869.70 MHz – 893.31 MHz	Pass
§2.1033 (c) (6) §2.1033 (c) (7) §2.1046 § 22.913	RSP 100 7.2 (a) RSS 129	RF power output at the antenna terminals	47.3 dBm to 47.8 dBm	ERP 57 dBm	Pass
	RSS GEN 4.4.1 RSS 129	99% Bandwidth	1.25 MHz	N/A	N/A
§2.1049 § 22.917 (b)		Occupied Bandwidth	1.32 MHz	N/A	N/A
Transmitter spurious emissions					
§2.1051 §2.1057	RSS 129	At the antenna terminals	< 20 dB margin	-13 dBm	Pass
§2.1053 §2.1057	RSS 129	Field strength	< 20 dB margin	-13 dBm	Pass
Receiver spurious emissions					
15.109	RSS 129 10(a)(d)	At the antenna terminals	< 10 dB margin	< 1GHz: 2 nW > 1GHz: 5 nW	Pass
15.109	RSS 129 10(a)(d)	Field strength	< 20 dB margin	See limit table on page 18	Pass
Other details					
§2.1055 § 22.355	RSS 129 9.2.1	Frequency stability	1.3 ppm	1.5 ppm	Pass
§2.1093	RS 102	RF Exposure	N/A	N/A	N/A
-	-	Antenna Gain	N/A	N/A	N/A
Notes					

EXTREME CONDITIONS

Frequency stability is determined over extremes of temperature and voltage.
 Extreme voltages are -40 Vdc and -68 Vdc
 The extremes of temperature were -30°C to +50°C as specified in FCC §2.1055(a)(1).

MEASUREMENT UNCERTAINTIES

ISO/IEC 17025 requires that an estimate of the measurement uncertainties associated with the emissions test results be included in the report. The measurement uncertainties given below are based on a 95% confidence level (based on a coverage factor (k=2) and were calculated in accordance with NAMAS document NIS 81 and M3003.

Measurement Type	Measurement Unit	Frequency Range	Expanded Uncertainty
RF frequency	Hz	25 to 7,000 MHz	1.7×10^{-7}
RF power, conducted	dBm	25 to 7,000 MHz	± 0.52 dB
Conducted emission of transmitter	dBm	25 to 40,000 MHz	± 0.7 dB
Conducted emission of receiver	dBm	25 to 40,000 MHz	± 0.7 dB
Radiated emission (substitution method)	dBm	25 to 40,000 MHz	± 2.5 dB
Radiated emission (field strength)	dBμV/m	25 to 1,000 MHz 1 to 40 GHz	± 3.6 dB ± 6.0 dB

EQUIPMENT UNDER TEST (EUT) DETAILS**GENERAL**

The Star Solutions iCell COMPAC 1X IP – RAN 800MHz CPU DC is a 1xRTT CDMA2000 Cellular Base Station which is designed to operate Tx: 869–894 MHz and Rx: 824–849 MHz. Since the EUT would normally be Pole Mounting, Wall Mounting or Floor Mounting during operation, the EUT was treated as floor-standing equipment during testing to simulate the end-user environment. The electrical rating of the EUT is - 48 Vdc. Power consumption is less than 150W (in typical operating conditions).

The sample was received on April 3, 2012 and tested on April 3, 4, 6 and 9, 2012. The EUT consisted of the following component(s):

Company	Model	Description	Serial Number	
Star Solutions	CX8011.0	CDMA2000 Cellular Base Station	17UEY1JMEM01	FCC ID: S52-1-09-00-00-1 IC: 8076A-10900001

OTHER EUT DETAILS

No antennas were provided with this sample.

The antenna(s) used for this transmitter must be fixed-mounted on permanent outdoor structures. RF exposure compliance is addressed at the time of licensing, as required by the responsible FCC Bureau(s), including antenna co-location requirements of Section 1.1037(b)(3).

ENCLOSURE

The EUT enclosure measures approximately 80 by 23 by 23 centimeters. It is primarily constructed of aluminum steel.

The EUT has no enclosure. It is designed to be installed within the enclosure of a host computer.

MODIFICATIONS

No modifications were made to the EUT during the time the product was at Elliott.

SUPPORT EQUIPMENT

The following equipment was used as support equipment for testing:

Company	Model	Description	Serial Number	FCC ID
Excelsys	LXV200-048S	Power supply	101023591	N/A

The following equipment was used as remote support equipment for emissions testing:

Company	Model	Description	Serial Number	FCC ID
DELL	Latitude D630	Laptop	17545509109	N/A

EUT INTERFACE PORTS

The I/O cabling configuration during testing was as follows:

Port	Connected To	Description	Cable(s)	
			Shielded or Unshielded	Length(m)
Ethernet	EUT	CAT 5E	Unshielded	2.0
AC Power	AC Mains	Three wire	Unshielded	1.0
DC Power	EUT	Two wire	Unshielded	0.3

EUT OPERATION

During RF conducted emissions testing the EUT was set to transmit at maximum power level. Diversity RF output was terminated with 50 Ohm loads. Measurements were performed at Main RF output. Diversity output is not active. The receiver emissions were performed at Main RF output with reduced RF power.

During frequency stability testing the EUT was set to transmit at maximum power level at center channel. The EUT was not able to generate un-modulated signal hence the measurements were taken on the modulated carrier signal

During radiated emissions testing the EUT was set to transmit at maximum power level with low, mid and high channels. Main and Diversity RF outputs are terminated with 50 Ohm loads

TESTING**GENERAL INFORMATION**

Antenna port measurements were taken at the Elliott Laboratories test site located at 41039 Boyce Road, Fremont, CA 94538-2435.

Radiated spurious emissions measurements were taken at the Elliott Laboratories Anechoic Chambers and/or Open Area Test Site(s) listed below. The sites conform to the requirements of ANSI C63.4: 2003 *American National Standard for Methods of Measurement of Radio-Noise Emissions from Low-Voltage Electrical and Electronic Equipment in the Range of 9 kHz to 40 GHz* and CISPR 16-1-4:2007 - *Specification for radio disturbance and immunity measuring apparatus and methods Part 1-4: Radio disturbance and immunity measuring apparatus Ancillary equipment Radiated disturbances*. They are on file with the FCC and industry Canada.

Site	Registration Numbers		Location
	FCC	Canada	
Chamber 5	211948	IC 2845B-5	41039 Boyce Road Fremont, CA 94538-2435

In the case of Open Area Test Sites, ambient levels are at least 6 dB below the specification limits with the exception of predictable local TV, radio, and mobile communications traffic.

Considerable engineering effort has been expended to ensure that the facilities conform to all pertinent requirements.

RF PORT MEASUREMENT PROCEDURES

Conducted measurements are performed with the EUT's rf input/output connected to the input of a spectrum analyzer, power meter or modulation analyzer. When required an attenuator, filter and/or dc block is placed between the EUT and the spectrum analyzer to avoid overloading the front end of the measurement device. Measurements are corrected for the insertion loss of the attenuators and cables inserted between the rf port of the EUT and the measurement equipment.

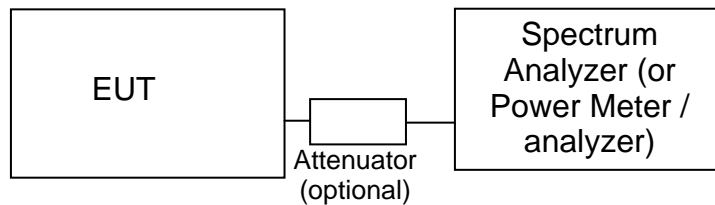

Test Configuration for Antenna Port Measurements

For devices with an integral antenna the output power and spurious emissions are measured as a field strength at a test distance of (typically) 3m and then converted to an eirp using a substitution measurement (refer to RADIATED EMISSIONS MEASUREMENTS). All other measurements are made as detailed below but with the test equipment connected to a measurement antenna directed at the EUT.

OUTPUT POWER

Output power is measured using a power meter and an average sensor head, a spectrum analyzer or a power meter and peak power sensor head as required by the relevant rule part(s). Where necessary measurements are gated to ensure power is only measured over periods that the device is transmitting.

Power measurements made directly on the rf power port are, when appropriate, converted to an EIRP by adding the gain of the highest gain antenna that can be used with the device under test, as specified by the manufacturer.

BANDWIDTH MEASUREMENTS

The 6dB, 20dB and/or 26dB signal bandwidth is measured in using the bandwidths recommended by ANSI C63.4. When required, the 99% bandwidth is measured using the methods detailed in RSS GEN. The measurement bandwidth is set to be at least 1% of the instrument's frequency span.

CONDUCTED SPURIOUS EMISSIONS

Initial scans are made using a peak detector (RBW=VBW) and using scan rates to ensure that the EUT transmits before the sweep moves out of each resolution bandwidth (for transmit mode measurements). Where the limits are expressed as an average power the spectrum analyzer is tuned to that frequency with a narrow span (wide enough to capture the emission and its sidebands) and the resolution and video bandwidths are adjusted as required by the reference measurement standards. For transmitter measurements the appropriate detector (average, peak, normal, sample, quasi-peak) is used when making measurements for licensed devices. For receiver conducted spurious measurements the detector is set to peak.

TRANSMITTER MASK MEASUREMENTS

The transmitter mask measurements are made using resolution bandwidths as specified in the pertinent rule part(s). Where narrower bandwidths are used the measurement is corrected to account for the reduced bandwidth by either using the adjacent channel power function of the spectrum analyzer to sum the power across the required measurement bandwidth. The frequency span of the analyzer is set to ensure the fundamental signal and all significant sidebands are displayed.

The top of the mask may be set by the total output power of the signal, the power of the unmodulated signal or the peak value of the signal in the reference bandwidth being used for the mask measurement.

FREQUENCY STABILITY

The EUT is placed inside a temperature chamber with all support and test equipment located outside of the chamber. The temperature is varied across the specified frequency range in 10 degree increments with frequency measurements made at each temperature step. The EUT is allowed enough time to stabilize at each temperature variation.

The spectrum analyzer is configured to give a 5- or 6-digit display for the marker-frequency function. The spectrum analyzer's built-in frequency counter is used to measure the maximum deviation of the fundamental frequency at each temperature. Where possible the device is set to transmit an unmodulated signal. Where this is not possible the frequency drift is determined by finding a stable point on the signal (e.g. the null at the centre of an OFDM signal) or by calculating a centre frequency based on the upper and lower XdB points (where X is typically 6dB or 10dB) on the signal's skirts.

TRANSIENT FREQUENCY BEHAVIOR:

The TIA/EIA 603 procedure is used to determine compliance with transient frequency timing requirements as the radio is keyed on and off.

The EUTs rf output is connected via a combiner/splitter to the test receiver/spectrum analyzer and to a diode detector. The test receiver or spectrum analyzer video output is connected to an oscilloscope, which is triggered by the output from the diode detector.

Plots showing Ton, T1, and T2 are made when turning on the transmitter and showing T3 when turning off the transmitter.

RADIATED EMISSIONS MEASUREMENTS

Receiver radiated spurious emissions measurements are made in accordance with ANSI C63.4:2003 by measuring the field strength of the emissions from the device at a specific test distance and comparing them to a field strength limit. Where the field strength limit is specified at a longer distance than the measurement distance the measurement is extrapolated to the limit distance.

Transmitter radiated spurious emissions are initially measured as a field strength. The eirp or erp limit as specified in the relevant rule part(s) is converted to a field strength at the test distance and the emissions from the EUT are then compared to that limit. Emissions within 20dB of this limit are the subjected to a substitution measurement.

All radiated emissions measurements are performed in two phases. A preliminary scan of emissions is conducted in either an anechoic chamber or on an OATS during which all significant EUT frequencies are identified with the system in a nominal configuration. At least two scans are performed across the complete frequency range of interest and at each operating frequency identified in the reference standard. One or more of these is with the antenna polarized vertically while the one or more of these is with the antenna polarized horizontally. Initial scans are made using a peak detector (RBW=VBW) and using scan rates to ensure that the EUT transmits before the sweep moves out of each resolution bandwidth (for transmit mode).

During the preliminary scans, the EUT is rotated through 360°, the antenna height is varied and cable positions are varied to determine the highest emission relative to the limit. For transmitter spurious emissions, where the limit is expressed as an effective radiated power, the eirp or erp is converted to a field strength limit.

Final measurements are made on an OATS or in a semi-anechoic chamber at the significant frequencies observed during the preliminary scan(s) using the same process of rotating the EUT and raising/lowering the measurement antenna to find the highest level of the emission. The field strength is recorded and, for receiver spurious emissions, compared to the field strength limit. For the final measurement the appropriate detectors (average, peak, normal, sample, quasi-peak) are used. For receiver measurements below 1GHz the detector is a Quasi-Peak detector, above 1GHz a peak detector is used and the peak value (RB=VB=1MHz) and average value (RB=1MHz, VB=10Hz) are recorded.

For transmitter spurious emissions, the radiated power of all emissions within 20dB of the calculated field strength limit are determined using a substitution measurement. The substitution measurement is made by replacing the EUT with an antenna of known gain (typically a dipole antenna or a double-ridged horn antenna), connected to a signal source. The output power of the signal generator is adjusted until the maximum field strength from the substitution antenna is similar to the field strength recorded from the EUT. The erp of the EUT is then calculated.

INSTRUMENTATION

An EMI receiver as specified in CISPR 16-1-1 is used for radiated emissions measurements. The receivers used can measure over the frequency range of 9 kHz up to 7000 MHz. These receivers allow both ease of measurement and high accuracy to be achieved. The receivers have Peak, Average, and CISPR (Quasi-peak) detectors built into their design so no external adapters are necessary.

For measurements above the frequency range of the receivers and for all conducted measurements a spectrum analyzer is utilized because it provides visibility of the entire spectrum along with the precision and versatility required to support engineering analysis.

Measurement bandwidths for the test instruments are set in accordance with the requirements of the standards referenced in this document.

Software control is used to correct the measurements for transducer factors (e.g. antenna) and the insertion loss of cables, attenuators and other series elements to obtain the final measurement value. This provides faster, more accurate readings by performing the conversions described under Sample Calculations within the Test Procedures section of this report. Results are exported in a graphic and/or tabular format, as appropriate.

FILTERS/ATTENUATORS

External filters and precision attenuators are often connected between the EUT antenna port or receiving antenna and the test receiver. This eliminates saturation effects and non-linear operation due to high amplitude transient events.

ANTENNAS

A combination of biconical, log periodic or bi-log antennas are used to cover the range from 30 MHz to 1000 MHz. Broadband antennas or tuned dipole antennas are used over the entire 25 to 1000 MHz frequency range as the reference antenna for substitution measurements.

Above 1000 MHz, a dual-ridge guide horn antenna or octave horn antenna are used as reference and measurement antennas.

The antenna calibration factors are included in site factors that are programmed into the test receivers and instrument control software when measuring the radiated field strength.

ANTENNA MAST AND EQUIPMENT TURNTABLE

The antennas used to measure the radiated electric field strength are mounted on a non-conductive antenna mast equipped with a motor-drive to vary the antenna height.

Table mounted devices are placed on a non-conductive table at a height of 80 centimeters above the floor. Floor mounted equipment is placed on the ground plane if the device is normally used on a conductive floor or separated from the ground plane by insulating material from 3 to 12 mm if the device is normally used on a non-conductive floor. The EUT is positioned on a motorized turntable to allow it to be rotated during testing to determine the angle with the highest level of emissions.

SAMPLE CALCULATIONS**SAMPLE CALCULATIONS - CONDUCTED SPURIOUS EMISSIONS**

Measurements are compared directly to the conducted emissions specification limit (decibel form). The calculation is as follows:

$$R_r - S = M$$

where:

$$\begin{aligned} R_r &= \text{Measured value in dBm} \\ S &= \text{Specification Limit in dBm} \\ M &= \text{Margin to Specification in +/- dB} \end{aligned}$$

SAMPLE CALCULATIONS - RADIATED FIELD STRENGTH

Measurements of radiated field strength are compared directly to the specification limit (decibel form). The receiver and/or control software corrects for cable loss, preamplifier gain, and antenna factor. The calculations are in the reverse direction of the actual signal flow, thus cable loss is added and the amplifier gain is subtracted. The Antenna Factor converts the voltage at the antenna coaxial connector to the field strength at the antenna elements.

A distance factor is used when measurements are made at a test distance that is different to the specified limit distance by using the following formula:

$$F_d = 20 * \text{LOG}_{10} (D_m/D_s)$$

where:

$$\begin{aligned} F_d &= \text{Distance Factor in dB} \\ D_m &= \text{Measurement Distance in meters} \\ D_s &= \text{Specification Distance in meters} \end{aligned}$$

For electric field measurements below 30MHz the extrapolation factor is either determined by making measurements at multiple distances or a theoretical value is calculated using the formula:

$$F_d = 40 * \text{LOG}_{10} (D_m/D_s)$$

The margin of a given emission peak relative to the limit is calculated as follows:

$$R_c = R_r + F_d$$

and

$$M = R_c - L_s$$

where:

- R_r = Receiver Reading in dBuV/m
 F_d = Distance Factor in dB
 R_c = Corrected Reading in dBuV/m
 L_s = Specification Limit in dBuV/m
 M = Margin in dB Relative to Spec

SAMPLE CALCULATIONS –RADIATED POWER

The erp/eirp limits for transmitter spurious measurements are converted to a field strength in free space using the following formula:

$$E = \frac{\sqrt{30 P G}}{d}$$

where:

- E = Field Strength in V/m
 P = Power in Watts
 G = Gain of isotropic antenna (numeric gain) = 1
 D = measurement distance in meters

The field strength limit is then converted to decibel form (dBuV/m) and the margin of a given emission peak relative to the limit is calculated (refer to *SAMPLE CALCULATIONS –RADIATED FIELD STRENGTH*).

When substitution measurements are required (all signals with less than 20dB of margin relative to the calculated field strength limit) the eirp of the spurious emission is calculated using:

$$P_{EUT} = P_s - (E_s - E_{EUT})$$

and

$$P_s = G + P_{in}$$

where:

- P_s = effective isotropic radiated power of the substitution antenna (dBm)
 P_{in} = power input to the substitution antenna (dBm)
 G = gain of the substitution antenna (dBi)
 E_s = field strength the substitution antenna (dBm) at eirp P_s
 E_{EUT} = field strength measured from the EUT

Where necessary the effective isotropic radiated power is converted to effective radiated power by subtracting the gain of a dipole (2.2dBi) from the eirp value.

RECEIVER RADIATED SPURIOUS EMISSIONS SPECIFICATION LIMITS

The table below shows the limits for the spurious emissions from receivers as detailed in FCC Part 15.109, RSS 210 Table 2, RSS GEN Table 1 and RSS 310 Table 3. Note that receivers operating outside of the frequency range 30 MHz – 960 MHz are exempt from the requirements of 15.109.

Frequency Range (MHz)	Limit ($\mu\text{V}/\text{m}$ @ 3m)	Limit ($\text{dB}\mu\text{V}/\text{m}$ @ 3m)
30 to 88	100	40
88 to 216	150	43.5
216 to 960	200	46.0
Above 960	500	54.0

Appendix A Test Equipment Calibration Data**Radio Antenna Port (Power and Spurious Emissions)**

<u>Manufacturer</u>	<u>Description</u>	<u>Model</u>	<u>Asset #</u>	<u>Cal Due</u>
Agilent	PSA, Spectrum Analyzer, (installed options, 111, 115, 123, 1DS, B7J, HYX,	E4446A	2139	2/23/2013
Agilent	MXG Analog Signal Generator	N5181A	2146	1/27/2013

Radiated Emissions

<u>Manufacturer</u>	<u>Description</u>	<u>Model</u>	<u>Asset #</u>	<u>Cal Due</u>
EMCO	Antenna, Horn, 1-18 GHz	3115	1561	6/22/2012
Sunol Sciences	Biconilog, 30-3000 MHz	JB3	1657	5/28/2012
Hewlett Packard	Microwave Preamplifier, 1- 26.5GHz	8449B	2199	2/23/2013
Com-Power Corp.	Preamplifier, 30-1000 MHz	PA-103A	2359	2/14/2013
Hewlett Packard	SpecAn 9 kHz - 40 GHz, (SA40) Purple	8564E (84125C)	2415	7/28/2012
Rohde & Schwarz	EMI Receiver	ESI-40	2493	12/9/2012

Appendix B Test Data

T87071 Pages 21 - 41



EMC Test Data

Client:	Star Solutions	Job Number:	J86373
Model Name:	iCell COMPAC 1X IP – RAN 800MHz CPU DC	T-Log Number:	T87071
Contact:	Azadeh Farzin [azadeh.farzin@starsolutions.com]	Account Manager:	Christine Krebill
Emissions Standard(s):	FCC Part 22 , RSS 129 Issue 2	Class:	-
Immunity Standard(s):	-	Environment:	Radio

EMC Test Data

For The

Star Solutions

Model

iCell COMPAC 1X IP – RAN 800MHz CPU DC

Date of Last Test: 5/2/2012

Client:	Star Solutions	Job Number:	J86373
Model Name:	iCell COMPAC 1X IP – RAN 800MHz CPU DC	T-Log Number:	T87071
		Account Manager:	Christine Krebill
Contact:	Azadeh Farzin [azadeh.farzin@starsolutions.com]		
Standard:	FCC Part 22 , RSS 129 Issue 2	Class:	N/A

RSS 129 Issue 2 and FCC Part 22 H
Power, Occupied Bandwidth, Frequency Stability and Spurious Emissions

Test Specific Details

Objective: The objective of this test session is to perform final qualification testing of the EUT with respect to the specification listed above.

General Test Configuration

With the exception of the radiated spurious emissions tests, all measurements are made with the EUT's rf port connected to the measurement instrument via an attenuator or dc-block if necessary. All amplitude measurements are adjusted to account for the attenuation between EUT and measuring instrument. For frequency stability measurements the EUT was place inside an environmental chamber.

Radiated measurements are made with the EUT located on a non-conductive table, 3m from the measurement antenna.

Ambient Conditions: Temperature: 22~25 °C
 Rel. Humidity: 35~45 %

Summary of Results

Run #	Spacing	Data Rate	Test Performed	Limit	Pass / Fail	Result / Margin
1	-	-	Output Power	ERP 57 dBm	Pass	47.8 dBm
1	-	-	99% Occupied Bandwidth	-	-	1.25 MHz
1	-	-	26dB Bandwidth	In Band	Pass	1.33 MHz
2a	-	-	Band Edge	-13 dBm	Pass	-1.11 dB
2b	-	-	Block Edge offset 750kHz	>45 dBc	Pass	-3.52 dB
2b	-	-	Block Edge offset 1.98MHz	>60 dBc	Pass	-7.23 dB
2c	-	-	Block Edge	-13 dBm	Pass	0 dB
3	-	-	TX Spurious Emissions (conducted)	-13 dBm	Pass	-59.8 dBm @ 2610.4 MHz (-46.8 dB)
4	-	-	RX Spurious Emissions (conducted)	See Table	Pass	Pass
5	-	-	Frequency Stability	1.5 ppm	Pass	1.3 ppm
6	-	-	TX Spurious Emissions (Radiated)	-13 dBm	Pass	30.5 dBμV/m @ 900.0 MHz (-43.4 dB)
7	-	-	RX Spurious Emissions (Radiated)	Table 10.1	Pass	Pass

Modifications Made During Testing

No modifications were made to the EUT during testing

Deviations From The Standard

No deviations were made from the requirements of the standard.

Client:	Star Solutions	Job Number:	J86373
Model Name:	iCell COMPAC 1X IP – RAN 800MHz CPU DC	T-Log Number:	T87071
Contact:	Azadeh Farzin [azadeh.farzin@starsolutions.com]	Account Manager:	Christine Krebill
Standard:	FCC Part 22 , RSS 129 Issue 2	Class:	N/A

Run #1: Output Power, 99% OBW, 26dB BW

Date of Test: 4/3/2012, 4/4/2012

Test Engineer: Jack Liu

Test Location: FT Power Fault

Config. Used: 1

Config Change: None

EUT Voltage: -48 Vdc

Test Method:

The EUT was setup via a computer and Star Solutions software to transmit at maximum power in 1xRTT mode, at the low, middle, and high ends of the frequency bands supported. The RF output power was measured using the spectrum analyzer with a maximum peak detector.

RF Output Power, 99% OBW, 26dB BW

Channel Number (Block)	Mode	Channel Frequency (MHz)	Measured Peak RF Output Power (dBm)	99% OBW (MHz)	26dB BW (MHz)
1015 (A')	1xRTT	869.76	47.7	1.25	1.33
309 (A)	1xRTT	879.27	47.8	1.25	1.31
358 (B)	1xRTT	880.74	47.4	1.25	1.32
642 (B)	1xRTT	889.26	47.7	1.25	1.31
691 (A')	1xRTT	890.73	47.3	1.25	1.32
692 (A')	1xRTT	890.76	47.5	1.25	1.32
741 (B')	1xRTT	892.23	47.5	1.25	1.32
775 (B')	1xRTT	893.25	47.8	1.25	1.32

Test Setup:

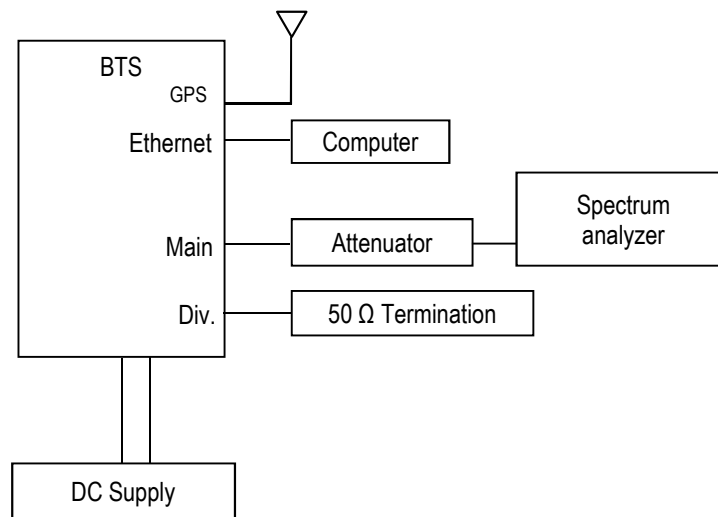

Client:	Star Solutions	Job Number:	J86373
Model Name:	iCell COMPAC 1X IP – RAN 800MHz CPU DC	T-Log Number:	T87071
Contact:	Azadeh Farzin [azadeh.farzin@starsolutions.com]	Account Manager:	Christine Krebill
Standard:	FCC Part 22 , RSS 129 Issue 2	Class:	N/A

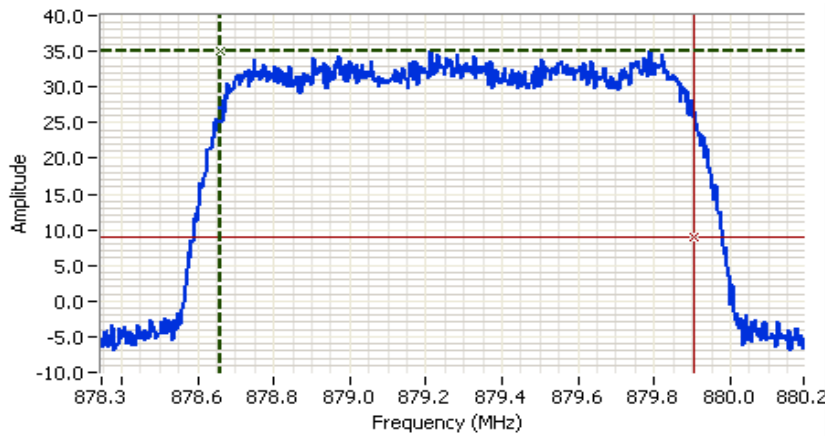

Analyzer Settings
 Agilent Technologies, E4446A
 CF: 879.270 MHz
 SPAN: 1.845 MHz
 RB: 30.0 kHz
 VB: 91.0 kHz
 Detector: POS
 Attn: 30 DB
 RL Offset: 30.0 DB
 Sweep Time: 1.0s
 Ref Lvl: 50.0 DBM

Comments
 99% power BW: 1.246 MHz
 Power over span: 47.78dBm
 CH309

Cursor 1 878.6576 35.04
 Cursor 2 879.9039 9.04

Delta Freq. 1.246
 Delta Amplitude 26.00

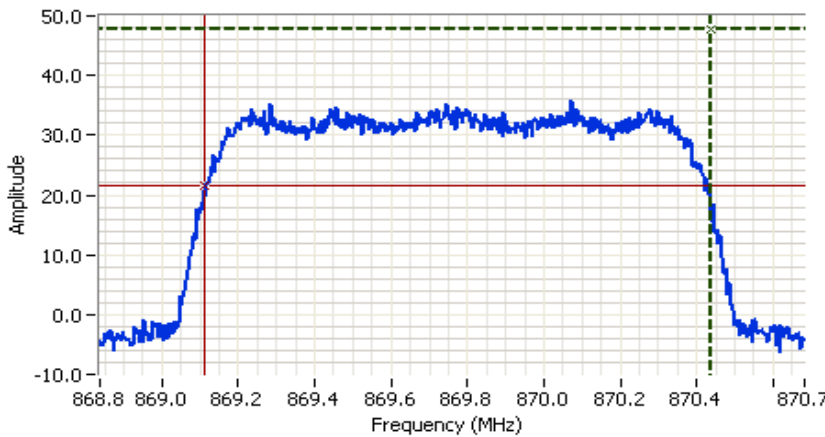

Analyzer Settings
 Agilent Technologies, E4446A
 CF: 869.760 MHz
 SPAN: 1.845 MHz
 RB: 30.0 kHz
 VB: 91.0 kHz
 Detector: POS
 Attn: 30 DB
 RL Offset: 30.0 DB
 Sweep Time: 1.0s
 Ref Lvl: 50.0 DBM

Comments
 26dB BW: 1.33 MHz
 CH 1015

Cursor 1 870.4375 47.70
 Cursor 2 869.1114 21.70

Delta Freq. 1.326
 Delta Amplitude 26.00



Client:	Star Solutions	Job Number:	J86373
Model Name:	iCell COMPAC 1X IP – RAN 800MHz CPU DC	T-Log Number:	T87071
Contact:	Azadeh Farzin [azadeh.farzin@starsolutions.com]	Account Manager:	Christine Krebill
Standard:	FCC Part 22 , RSS 129 Issue 2	Class:	N/A

Run# 2: In Band Unwanted Emission, Band Edge

Date of Test: 4/3/2012, 4/4/2012
 Test Engineer: Jack Liu
 Test Location: FT Power Fault

Config. Used: 1
 Config Change: None
 EUT Voltage: -48 Vdc

Test Method:

The EUT was setup via a computer and Star Solutions software to transmit at maximum power in 1xRTT mode, at the low and high ends of the frequency bands supported. The RF output power was measured using the spectrum analyzer with maximum peak detector with power integration over 30 kHz with RBW: 1 kHz and VBW: 1 kHz

Run 2a: Band Edge- Unwanted Emissions from Base Stations(30 kHz outside the cellular band)

Channel Number (Block)	Mode	Channel Frequency (MHz)	Measured Band Edge Power (dBm)	Limit (dBm)	Margin (dB)
1015 (A')	1xRTT	869.76	-14.11	-13.00	-1.11
775 (B')	1xRTT	893.25	-16.96	-13.00	-3.96

Test Setup:

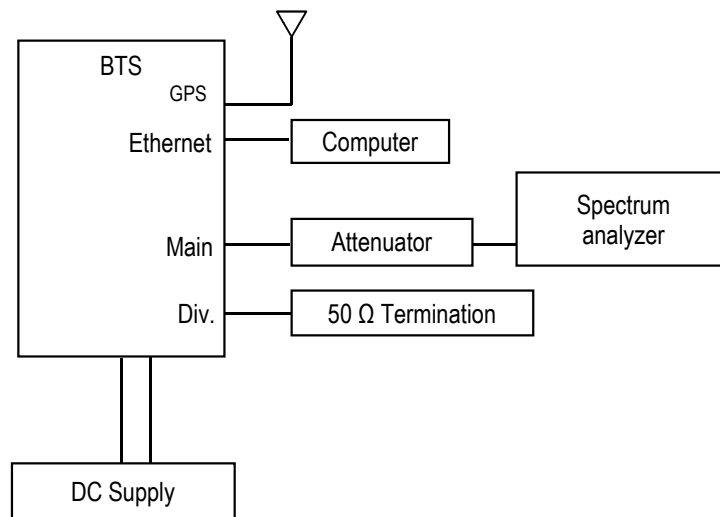

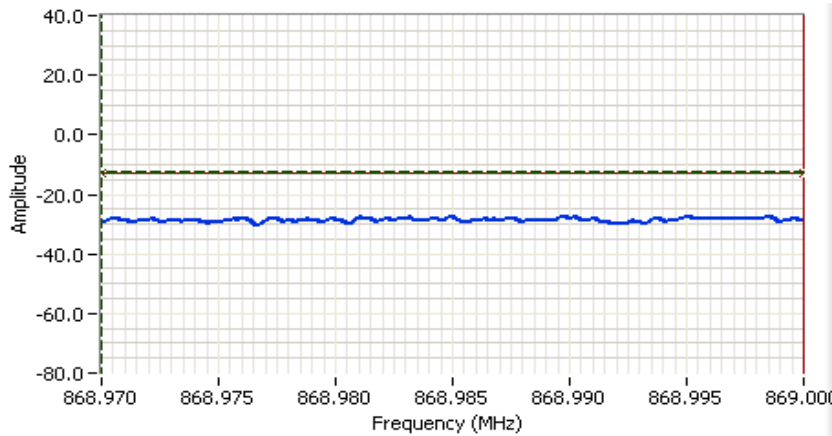

Client:	Star Solutions	Job Number:	J86373
Model Name:	iCell COMPAC 1X IP – RAN 800MHz CPU DC	T-Log Number:	T87071
Contact:	Azadeh Farzin [azadeh.farzin@starsolutions.com]	Account Manager:	Christine Krebill
Standard:	FCC Part 22 , RSS 129 Issue 2	Class:	N/A



Analyzer Settings
 Agilent Technologies, E4446A
 CF: 868.985 MHz
 SPAN: 30.0 kHz
 RB: 1.00 kHz
 VB: 10.0 kHz
 Detector: POS
 Attn: 20 DB
 RL Offset: 30.0 DB
 Sweep Time: 27.7ms
 Ref Lvl: 40.0 DBM
 Vavg: 100

Comments
 Power over span: -14.11dBm
 CH1015

Cursor 1 868.9700 -13.00 

Cursor 2 869.0000 -13.00 

Delta Freq. 30.0 kHz

Delta Amplitude 0.00

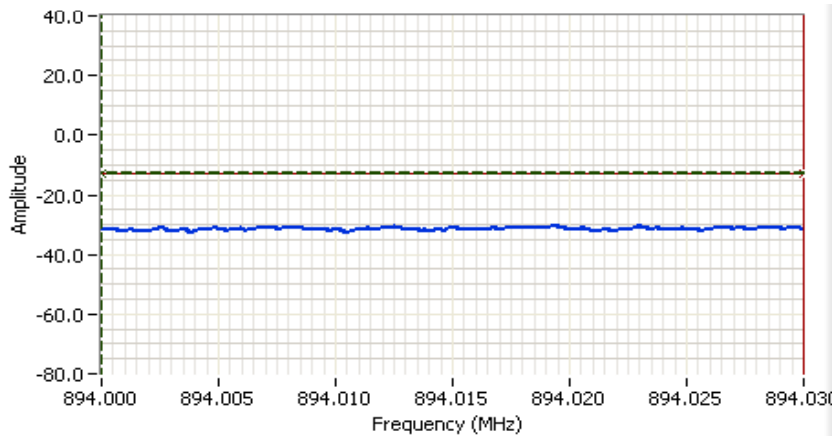

Analyzer Settings
 Agilent Technologies, E4446A
 CF: 894.015 MHz
 SPAN: 30.0 kHz
 RB: 1.00 kHz
 VB: 10.0 kHz
 Detector: POS
 Attn: 20 DB
 RL Offset: 30.0 DB
 Sweep Time: 27.7ms
 Ref Lvl: 40.0 DBM
 Vavg: 100

Comments
 Power over span: -16.96dBm
 CH 775

Cursor 1 894.0000 -13.00 

Cursor 2 894.0300 -13.00 

Delta Freq. 30.0 kHz

Delta Amplitude 0.00



Client:	Star Solutions	Job Number:	J86373
Model Name:	iCell COMPAC 1X IP – RAN 800MHz CPU DC	T-Log Number:	T87071
Contact:	Azadeh Farzin [azadeh.farzin@starsolutions.com]	Account Manager:	Christine Krebill
Standard:	FCC Part 22 , RSS 129 Issue 2	Class:	N/A

Run 2b: Unwanted Emissions, 750 kHz and 1.98 MHz Offset Frequencies (RSS-129 Issue 2, Clause 8.1.2 (1)(a)(b))

Channel Number (Block)	Mode	Channel Frequency (MHz)	Offset (MHz)	Measured (dBc)	Limit (dBc)	Margin (dB)
1015 (A')	1xRTT	869.76	-0.75	-48.52	-45.00	-3.52
1015 (A')	1xRTT	869.76	-1.98	-68.63	-60.00	-8.63
1015 (A')	1xRTT	869.76	0.75	-49.16	-45.00	-4.16
1015 (A')	1xRTT	869.76	1.98	-69.41	-60.00	-9.41
383 (B)	1xRTT	881.49	-0.75	-49.25	-45.00	-4.25
383 (B)	1xRTT	881.49	-1.98	-67.23	-60.00	-7.23
383 (B)	1xRTT	881.49	0.75	-49.77	-45.00	-4.77
383 (B)	1xRTT	881.49	1.98	-67.82	-60.00	-7.82
775 (B')	1xRTT	893.25	-0.75	-50.44	-45.00	-5.44
775 (B')	1xRTT	893.25	-1.98	-67.81	-60.00	-7.81
775 (B')	1xRTT	893.25	0.75	-50.09	-45.00	-5.09
775 (B')	1xRTT	893.25	1.98	-68.52	-60.00	-8.52

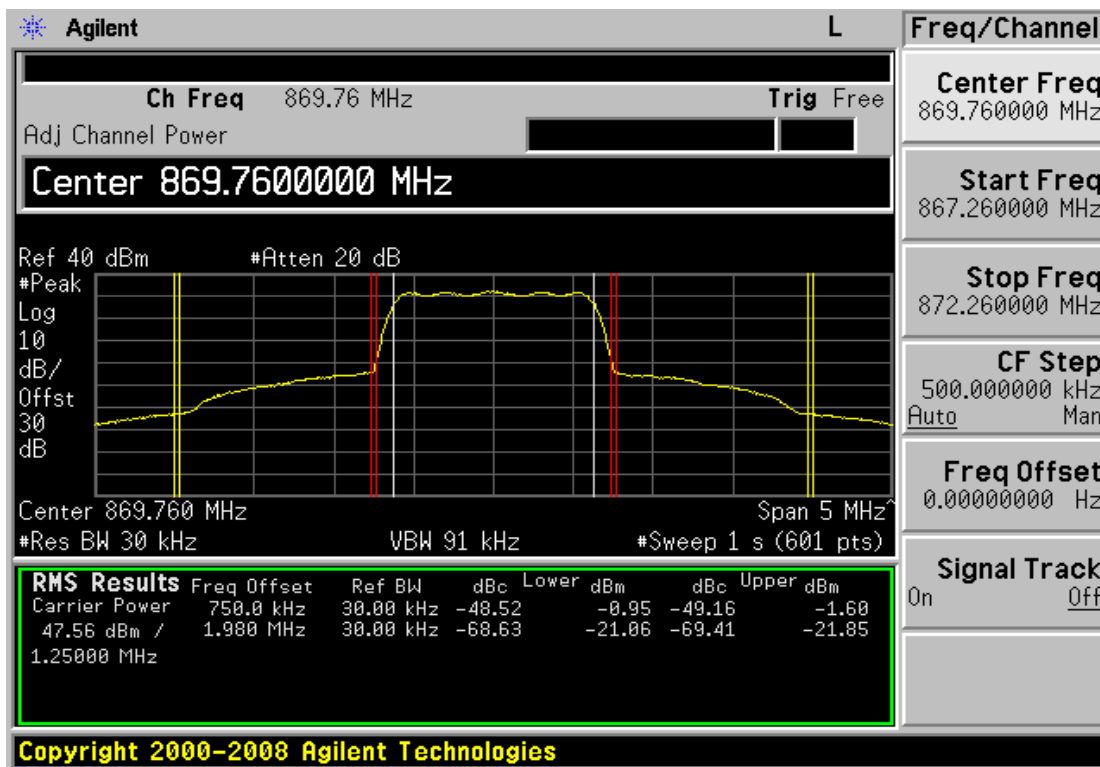

Client:	Star Solutions	Job Number:	J86373
Model Name:	iCell COMPAC 1X IP – RAN 800MHz CPU DC	T-Log Number:	T87071
Contact:	Azadeh Farzin [azadeh.farzin@starsolutions.com]	Account Manager:	Christine Krebill
Standard:	FCC Part 22 , RSS 129 Issue 2	Class:	N/A

Run 2c: Block Edge Unwanted Emissions (RSS-129 Issue 2, Clause 8.1.2 (1) (c))

Channel Number (Block)	Mode	Channel Frequency (MHz)	Block Edge (MHz)	Measured Block Edge power (dBm)	Limit (dBm)	Margin (dB)
309 (A)	1xRTT	879.27	880.00	-13.00	-13.00	0.00
358 (B)	1xRTT	880.74	880.00	-14.53	-13.00	-1.53
642 (B)	1xRTT	889.26	890.00	-14.98	-13.00	-1.98
691 (A')	1xRTT	890.73	890.00	-13.94	-13.00	-0.94
692 (A')	1xRTT	890.76	891.50	-16.21	-13.00	-3.21
741 (B')	1xRTT	892.23	891.50	-13.81	-13.00	-0.81

Test Setup:

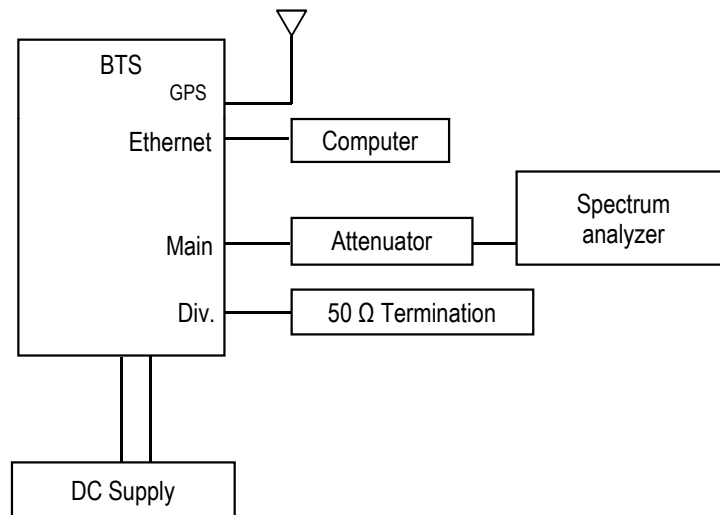

Client:	Star Solutions	Job Number:	J86373
Model Name:	iCell COMPAC 1X IP – RAN 800MHz CPU DC	T-Log Number:	T87071
Contact:	Azadeh Farzin [azadeh.farzin@starsolutions.com]	Account Manager:	Christine Krebill
Standard:	FCC Part 22 , RSS 129 Issue 2	Class:	N/A

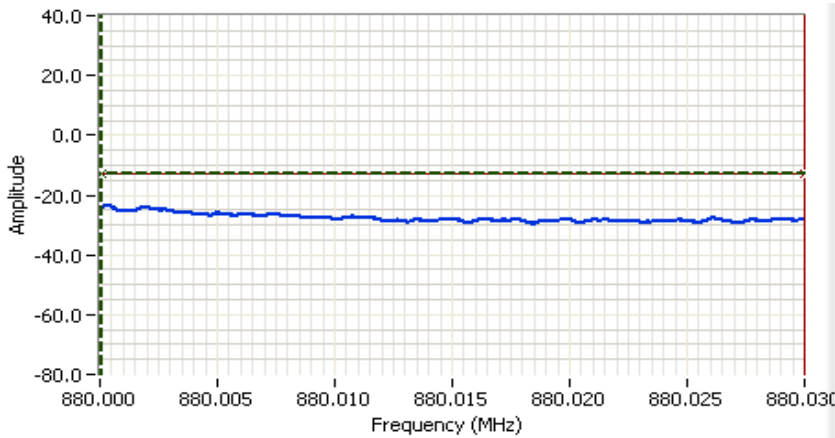

Analyzer Settings
 Agilent Technologies, E4446A
 CF: 880.015 MHz
 SPAN: 30.0 kHz
 RB: 1.00 kHz
 VB: 10.0 kHz
 Detector: POS
 Attn: 20 DB
 RL Offset: 30.0 DB
 Sweep Time: 27.7ms
 Ref Lvl: 40.0 DBM
 Vavg: 100

Comments
 Power over span: -13.00dBm
 CH 309

Cursor 1 880.0000 -13.00

Cursor 2 880.0300 -13.00

Delta Freq. 30.0 kHz

Delta Amplitude 0.00

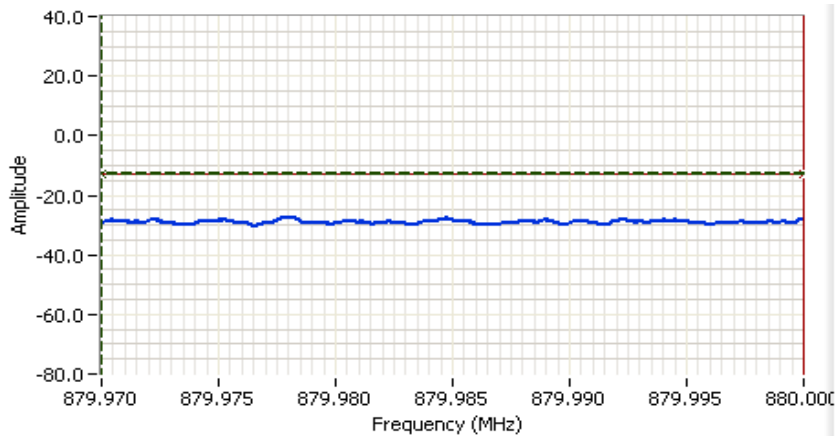

Analyzer Settings
 Agilent Technologies, E4446A
 CF: 879.985 MHz
 SPAN: 30.0 kHz
 RB: 1.00 kHz
 VB: 10.0 kHz
 Detector: POS
 Attn: 20 DB
 RL Offset: 30.0 DB
 Sweep Time: 27.7ms
 Ref Lvl: 40.0 DBM
 Vavg: 100

Comments
 Power over span: -14.53dBm
 CH 358

Cursor 1 879.9700 -13.00

Cursor 2 880.0000 -13.00

Delta Freq. 30.0 kHz

Delta Amplitude 0.00



Client:	Star Solutions	Job Number:	J86373
Model Name:	iCell COMPAC 1X IP – RAN 800MHz CPU DC	T-Log Number:	T87071
Contact:	Azadeh Farzin [azadeh.farzin@starsolutions.com]	Account Manager:	Christine Krebill
Standard:	FCC Part 22 , RSS 129 Issue 2	Class:	N/A

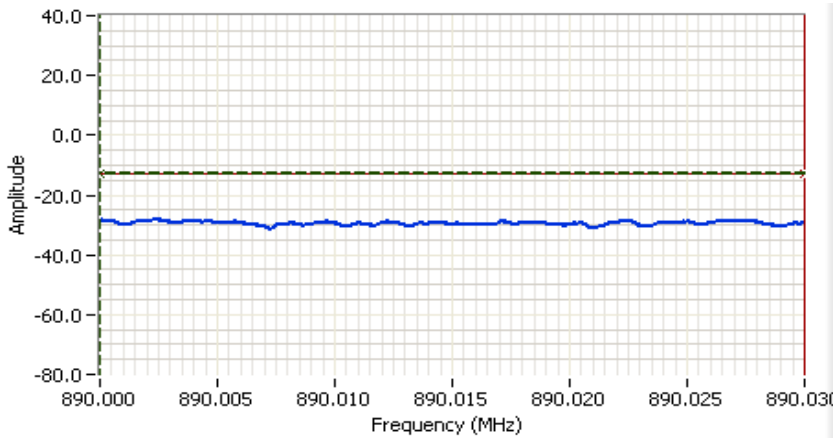

Analyzer Settings
 Agilent Technologies, E4446A
 CF: 890.015 MHz
 SPAN: 30.0 kHz
 RB: 1.00 kHz
 VB: 10.0 kHz
 Detector: POS
 Attn: 20 DB
 RL Offset: 30.0 DB
 Sweep Time: 27.7ms
 Ref Lvl: 40.0 DBM
 Vavg: 100

Comments
 Power over span: -14.98dBm
 CH 642

Cursor 1 890.0000 -13.00

Cursor 2 890.0300 -13.00

Delta Freq. 30.0 kHz

Delta Amplitude 0.00

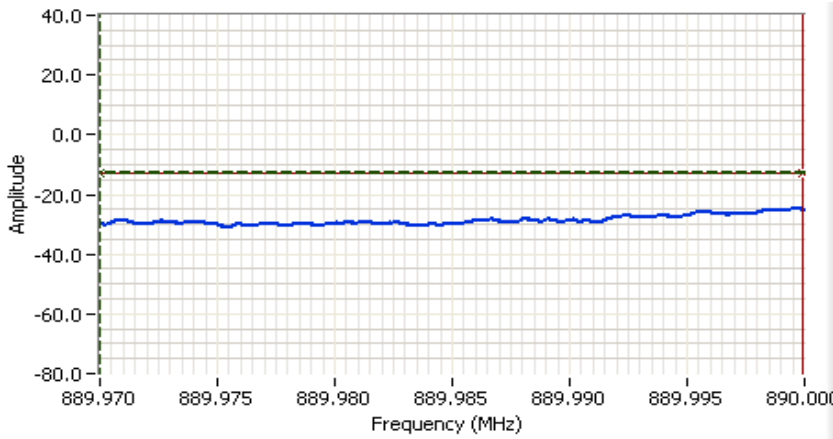

Analyzer Settings
 Agilent Technologies, E4446A
 CF: 889.985 MHz
 SPAN: 30.0 kHz
 RB: 1.00 kHz
 VB: 10.0 kHz
 Detector: POS
 Attn: 20 DB
 RL Offset: 30.0 DB
 Sweep Time: 27.7ms
 Ref Lvl: 40.0 DBM
 Vavg: 100

Comments
 Power over span: -13.94dBm
 CH 691

Cursor 1 889.9700 -13.00

Cursor 2 890.0000 -13.00

Delta Freq. 30.0 kHz

Delta Amplitude 0.00



Client:	Star Solutions	Job Number:	J86373
Model Name:	iCell COMPAC 1X IP – RAN 800MHz CPU DC	T-Log Number:	T87071
Contact:	Azadeh Farzin [azadeh.farzin@starsolutions.com]	Account Manager:	Christine Krebill
Standard:	FCC Part 22 , RSS 129 Issue 2	Class:	N/A

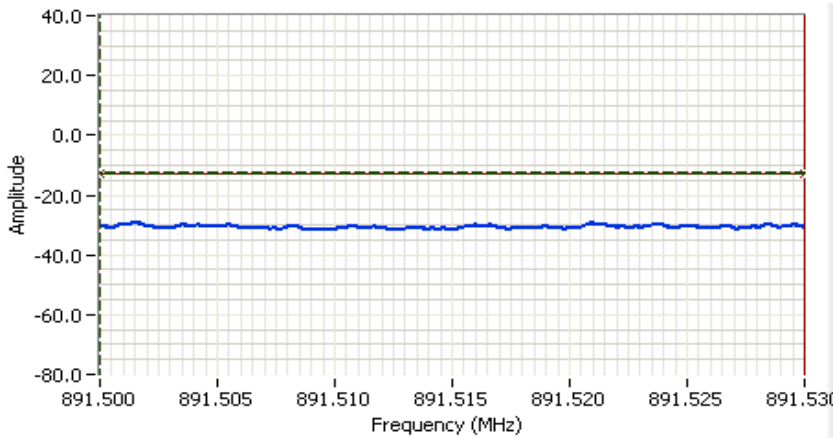

Analyzer Settings
 Agilent Technologies, E4446A
 CF: 891.515 MHz
 SPAN: 30.0 kHz
 RB: 1.00 kHz
 VB: 10.0 kHz
 Detector: POS
 Attn: 20 DB
 RL Offset: 30.0 DB
 Sweep Time: 27.7ms
 Ref Lvl: 40.0 DBM
 Vavg: 100

Comments
 Power over span: -16.21dBm
 CH 692

Cursor 1 891.5000 -13.00   

Cursor 2 891.5300 -13.00   

Delta Freq. 30.0 kHz

Delta Amplitude 0.00

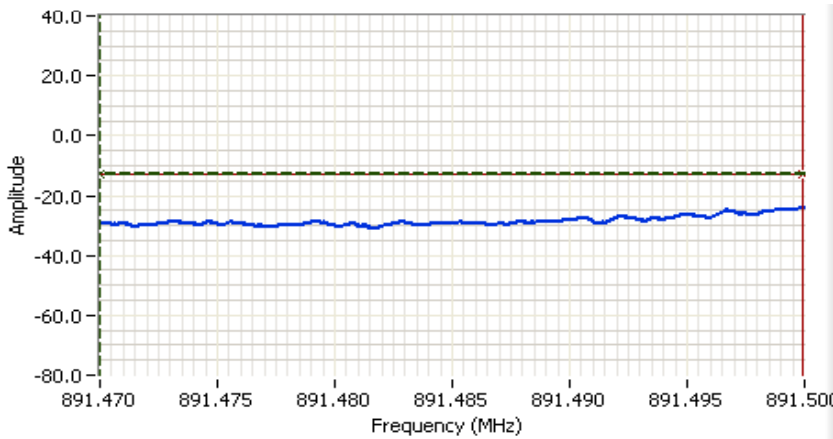

Analyzer Settings
 Agilent Technologies, E4446A
 CF: 891.485 MHz
 SPAN: 30.0 kHz
 RB: 1.00 kHz
 VB: 10.0 kHz
 Detector: POS
 Attn: 20 DB
 RL Offset: 30.0 DB
 Sweep Time: 27.7ms
 Ref Lvl: 40.0 DBM
 Vavg: 100

Comments
 Power over span: -13.81dBm
 CH 741

Cursor 1 891.4700 -13.00   

Cursor 2 891.5000 -13.00   

Delta Freq. 30.0 kHz

Delta Amplitude 0.00



Client:	Star Solutions	Job Number:	J86373
Model Name:	iCell COMPAC 1X IP – RAN 800MHz CPU DC	T-Log Number:	T87071
Contact:	Azadeh Farzin [azadeh.farzin@starsolutions.com]	Account Manager:	Christine Krebill
Standard:	FCC Part 22 , RSS 129 Issue 2	Class:	N/A

Run #3: (TX) Out of Band Spurious Emissions, Conducted

Date of Test: 4/5/2012 0:00

Test Engineer: Deniz

Test Location: FT Power Fault

Config. Used: 1

Config Change: None

EUT Voltage: -48 Vdc

Plots for low channel, Full Power

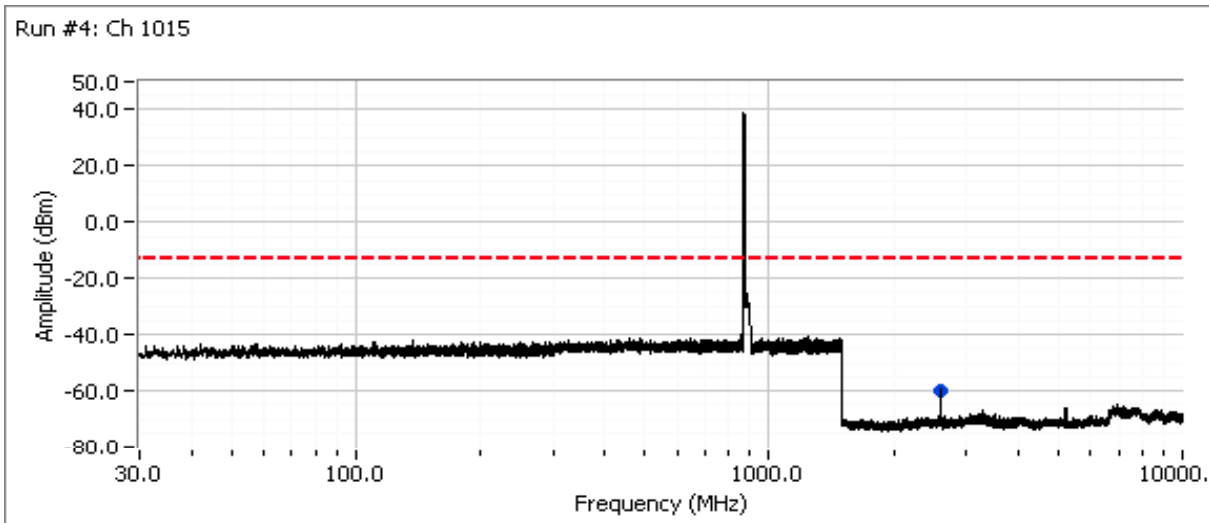

Plots for center channel, Full Power

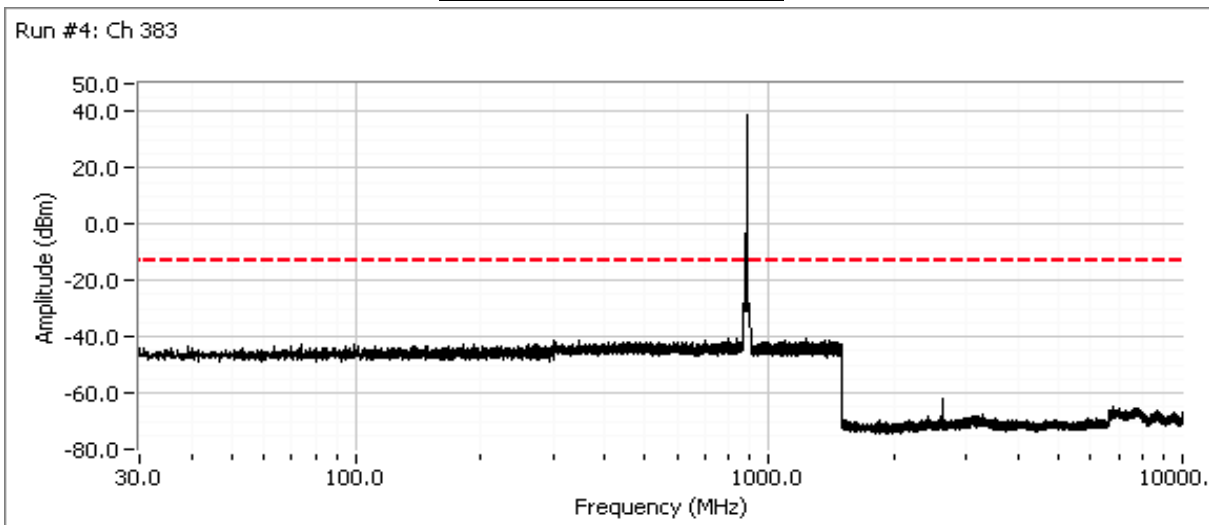

Client:	Star Solutions	Job Number:	J86373
Model Name:	iCell COMPAC 1X IP – RAN 800MHz CPU DC	T-Log Number:	T87071
Contact:	Azadeh Farzin [azadeh.farzin@starsolutions.com]	Account Manager:	Christine Krebill
Standard:	FCC Part 22 , RSS 129 Issue 2	Class:	N/A

Plots for high channel, Full Power

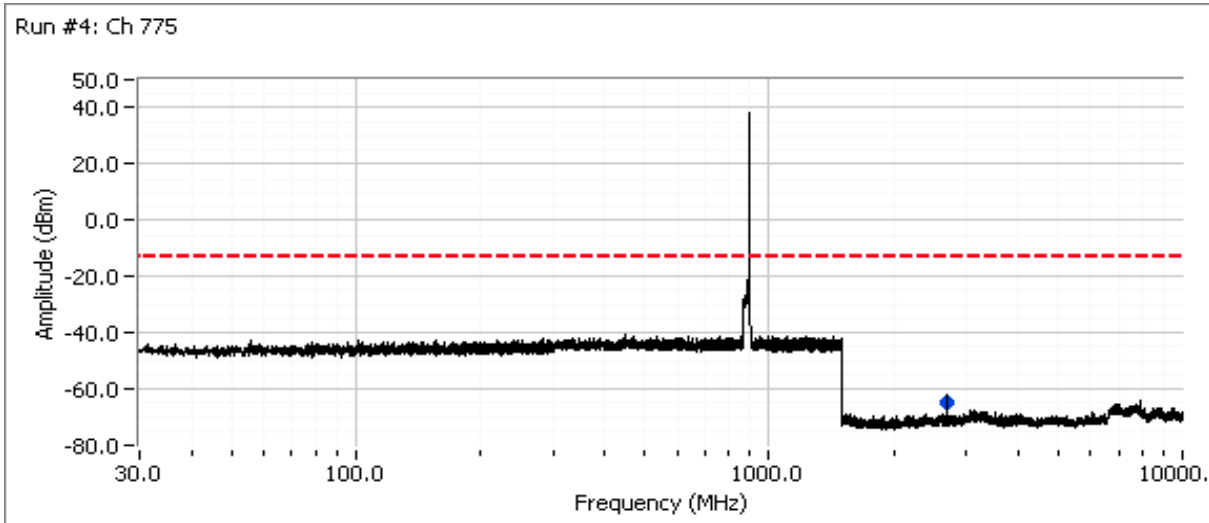

Frequency MHz	Level dBm	Port	FCC 22 & RSS129		Detector Pk/QP/Avg	Azimuth degrees	Height meters	Comments		Channel
			Limit	Margin						
2610.370	-59.8	RF Port	-13.0	-46.8	Peak	-	-	-		1015
2646.220	-61.0	RF Port	-13.0	-48.0	Peak	-	-	-		383
2679.600	-61.2	RF Port	-13.0	-48.2	Peak	-	-	-		775

Client:	Star Solutions	Job Number:	J86373
Model Name:	iCell COMPAC 1X IP – RAN 800MHz CPU DC	T-Log Number:	T87071
Contact:	Azadeh Farzin [azadeh.farzin@starsolutions.com]	Account Manager:	Christine Krebill
Standard:	FCC Part 22 , RSS 129 Issue 2	Class:	N/A

Run #4: (RX) Out of Band Spurious Emissions, Conducted

Date of Test: 4/11/2012 0:00
 Test Engineer: Deniz
 Test Location: FT Power Fault

Config. Used: 1
 Config Change: Reduced Tx power (See test method)
 EUT Voltage: -48 Vdc

Test Method:

The EUT was setup via a computer and Star Solutions software to transmit at reduced power (26 dBm) in 1xRTT mode, at the low, middle, and high ends of the frequency bands supported. The RF output power was measured using the spectrum analyzer with a maximum peak detector. A Tunable Band Reject Filter (K&L 3 INF-800/1000-0.2 S/N 13) was used for 30 MHz to 1.5 GHz measurements. 1.5 GHz HPF was used for 1.5 GHz to 10 GHz measurements. Plots are combined with Elliott EMC 2.10 software
 Requirement: No spurious output signals appearing at the antenna terminals shall exceed 2 nanowatts (-57 dBm) per any 4 kHz spurious frequency in the band 30-1000 MHz or 5 nanowatts (-53 dBm) above 1 GHz.

Test Result: Pass, There was no receiver related emission observed

Plots for low channel

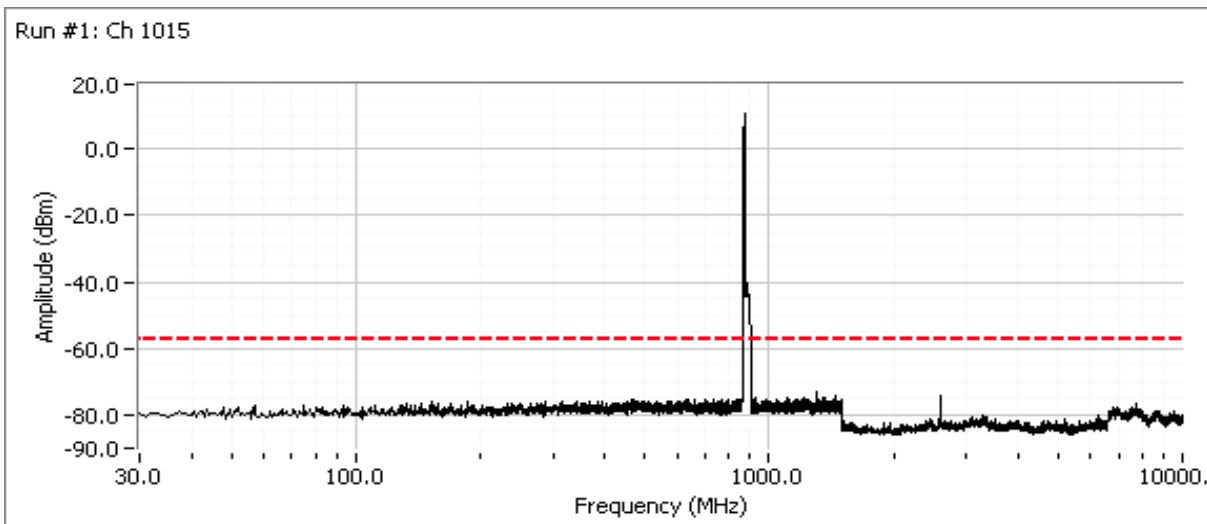

Client:	Star Solutions	Job Number:	J86373
Model Name:	iCell COMPAC 1X IP – RAN 800MHz CPU DC	T-Log Number:	T87071
Contact:	Azadeh Farzin [azadeh.farzin@starsolutions.com]	Account Manager:	Christine Krebill
Standard:	FCC Part 22 , RSS 129 Issue 2	Class:	N/A

Plots for center channel

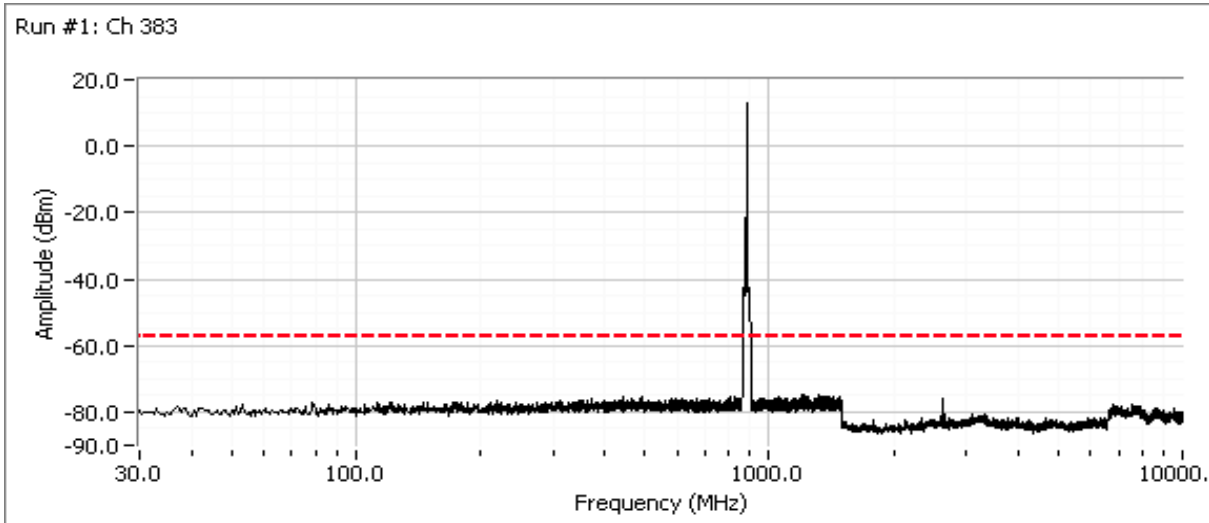

Plots for high channel

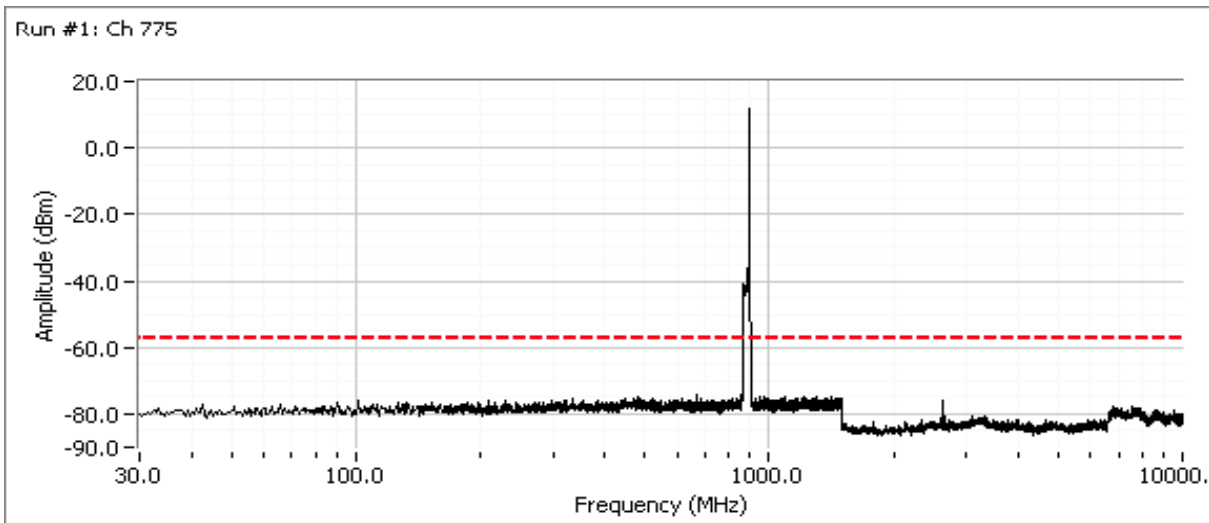

Client:	Star Solutions	Job Number:	J86373
Model Name:	iCell COMPAC 1X IP – RAN 800MHz CPU DC	T-Log Number:	T87071
Contact:	Azadeh Farzin [azadeh.farzin@starsolutions.com]	Account Manager:	Christine Krebill
Standard:	FCC Part 22 , RSS 129 Issue 2	Class:	N/A

Run #5: Frequency Stability

Date: 4/6/2012 Engineer: Jack/Deniz Location: Newark chamber 10
 Nominal Frequency: 881.49 MHz

Test Setup:

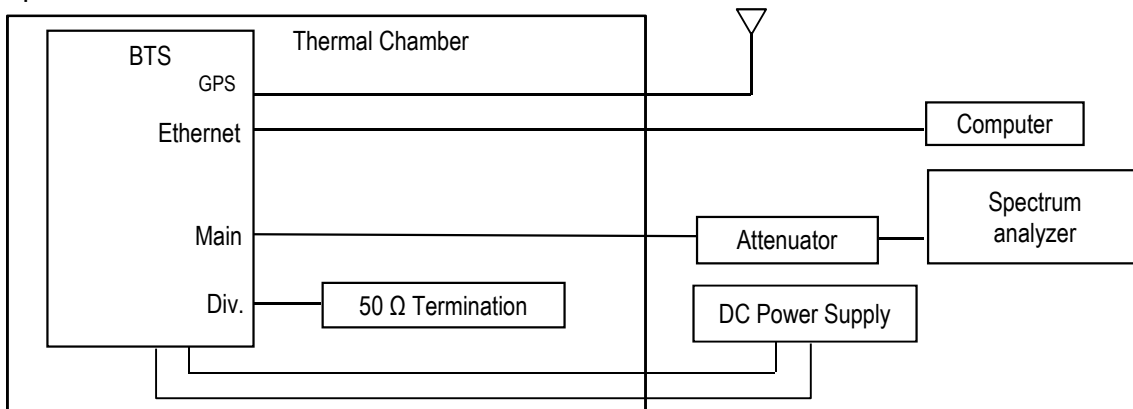

Frequency Stability Over Temperature

The EUT was soaked at each temperature for a minimum of 30 minutes prior to making the measurements to ensure the EUT and chamber had stabilized at that temperature. The EUT was not able to generate CW signal hence the readings were taken with modulated signal, using ndB down method with a spectrum analyzer

Temperature (Celsius)	Frequency Measured (MHz)	Drift	
		(Hz)	(ppm)
-30	Trasmitter will not key on	-	-
-28	881.491150	1150	1.3
-20	881.490950	950	1.1
-10	881.491050	1050	1.2
0	881.489300	-700	0.8
10	881.491150	1150	1.3
20	881.491187	1187	1.3
30	881.489850	-150	0.2
40	881.489900	-100	0.1
50	881.490200	200	0.2
Worst case:		1187	1.3

Frequency Stability Over Input Voltage (Nominal Voltage is -48 Vdc.)

Voltage (dc)	Frequency Measured (MHz)	Drift	
		(Hz)	(ppm)
-40	881.489995	-5	0.0
-68	881.489998	-3	0.0



Radio Test Data

Client:	Star Solutions	Job Number:	J86373
Model Name:	iCell COMPAC 1X IP – RAN 800MHz CPU DC	T-Log Number:	T87071
Contact:	Azadeh Farzin [azadeh.farzin@starsolutions.com]	Account Manager:	Christine Krebill
Standard:	FCC Part 22 , RSS 129 Issue 2	Class:	N/A

Run #6: Out of Band Spurious Emissions, Radiated (TX Mode)

Conducted limit (dBm): -13 erp
 Approximate field strength limit @ 3m: 84.3 (1 GHz to 10 GHz measurements)
 Approximate field strength limit @ 10m: 73.9 (30 MHz to 1 GHz measurements)

Run #6a - Preliminary measurements - chamber scans

Date: 4/9/2012 Engineer Jack/ Deniz Location: FT 5

Frequency MHz	Level dB μ V/m	Pol v/h	FCC 22 & RSS129		Detector Pk/QP/Avg	Azimuth degrees	Height meters	Comments	Channel
			Limit	Margin					
900.026	30.5	V	73.9	-43.4	Peak	219	1.0		1015
900.059	30.4	V	73.9	-43.5	Peak	210	1.0		383
866.659	29.0	V	73.9	-44.9	Peak	203	1.0		383
698.211	28.7	V	73.9	-45.2	Peak	231	1.0		1015
47.864	27.9	V	73.9	-46.0	Peak	193	1.5		775
866.669	27.9	V	73.9	-46.0	Peak	231	1.0		775
696.539	26.8	V	73.9	-47.1	Peak	246	1.0		775
48.990	26.7	V	73.9	-47.2	Peak	200	2.0		383
798.732	26.3	V	73.9	-47.6	Peak	228	1.0		383
500.013	24.9	V	73.9	-49.0	Peak	231	1.0		1015
552.974	24.9	V	73.9	-49.0	Peak	203	1.0		383
500.013	23.5	V	73.9	-50.4	Peak	241	1.0		775
50.119	21.7	V	73.9	-52.2	Peak	203	1.5		1015
105.690	21.7	V	73.9	-52.2	Peak	163	1.0		383
105.676	20.3	V	73.9	-53.6	Peak	226	1.0		1015
144.708	18.4	V	73.9	-55.5	Peak	187	1.5		1015
105.715	14.5	V	73.9	-59.4	Peak	127	1.0		775
1100.020	30.8	V	84.3	-53.5	Peak	199	1.6		1015
3000.230	32.6	V	84.3	-51.7	Peak	224	1.7		775
6480.960	34.7	V	84.3	-49.6	Peak	94	1.6		383
8243.030	37.9	H	84.3	-46.4	Peak	194	1.6	Noise floor	1015
9900.680	39.0	V	84.3	-45.3	Peak	346	1.9	Noise floor	383
9922.810	40.1	H	84.3	-44.2	Peak	74	2.2	Noise floor	775

Note 1:	The field strength limit in the tables above was calculated from the erp/eirp limit detailed in the standard using the free space propagation equation: $E = \sqrt{(30PG)/d}$. This limit is conservative - it does not consider the presence of the ground plane and, for erp limits, the dipole gain of 2.1 dBi has been included. The erp or eirp for all signals with less than 20dB of margin relative to this field strength limit is determined using substitution measurements.
Note 2:	All emissions > 20 dB below the equivalent field strength limit. Substitutions not required.
Note 3:	Measurements are made with the antenna port terminated.

Client:	Star Solutions	Job Number:	J86373
Model Name:	iCell COMPAC 1X IP – RAN 800MHz CPU DC	T-Log Number:	T87071
Contact:	Azadeh Farzin [azadeh.farzin@starsolutions.com]	Account Manager:	Christine Krebill
Standard:	FCC Part 22 , RSS 129 Issue 2	Class:	N/A

Plots for low channel, Full Power.

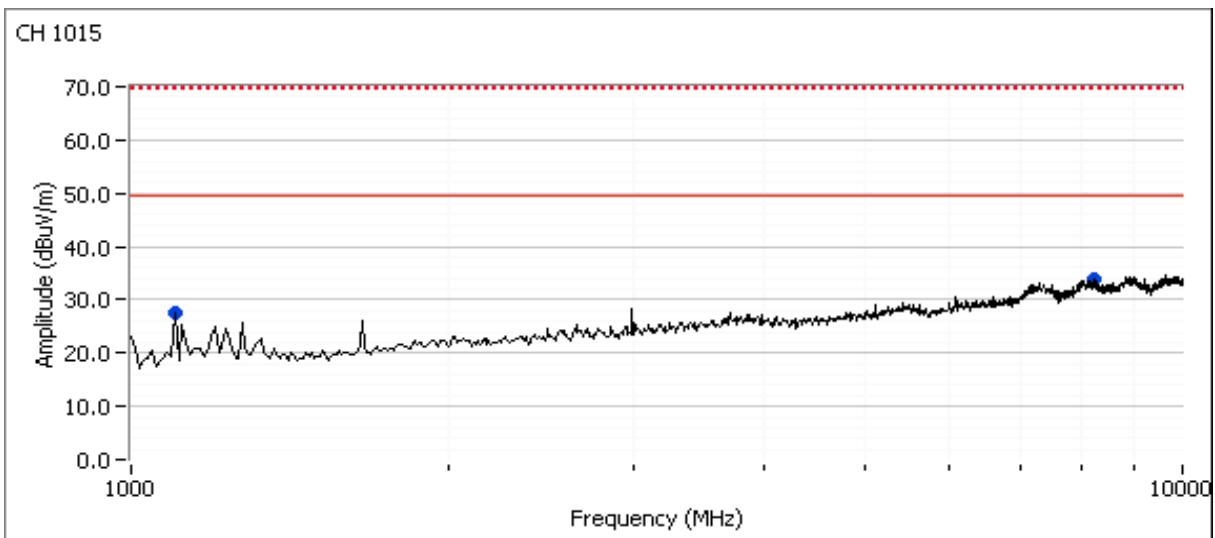
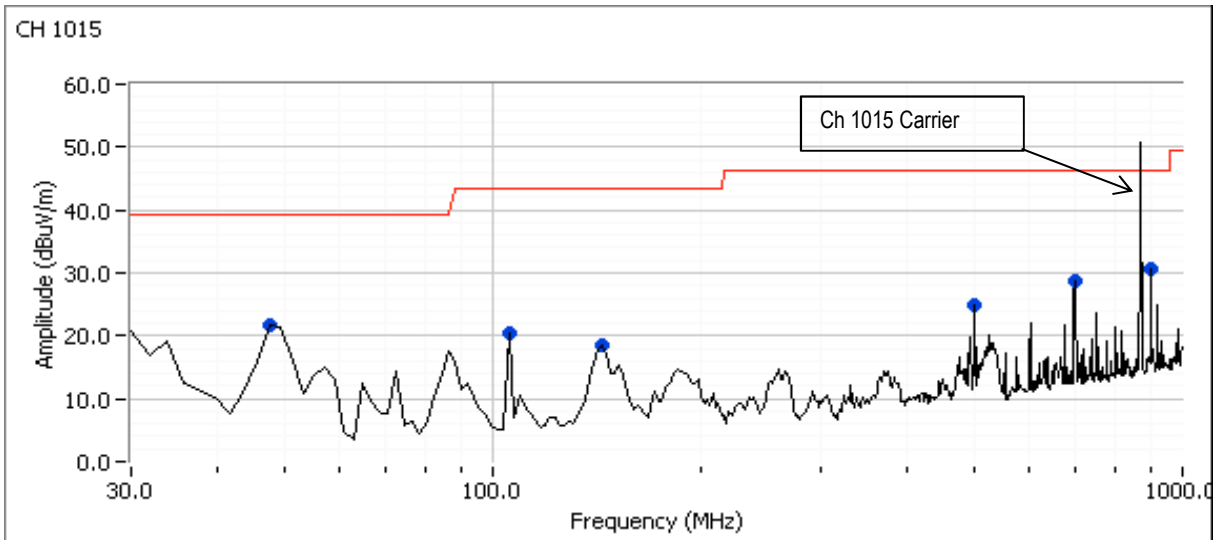

Note: FCC Part 15 Subpart B and ICES-003 Class A limits applied to show compliance with unintentional spurious emission limits

Client:	Star Solutions	Job Number:	J86373
Model Name:	iCell COMPAC 1X IP – RAN 800MHz CPU DC	T-Log Number:	T87071
Contact:	Azadeh Farzin [azadeh.farzin@starsolutions.com]	Account Manager:	Christine Krebill
Standard:	FCC Part 22 , RSS 129 Issue 2	Class:	N/A

Plots for center channel, Full Power

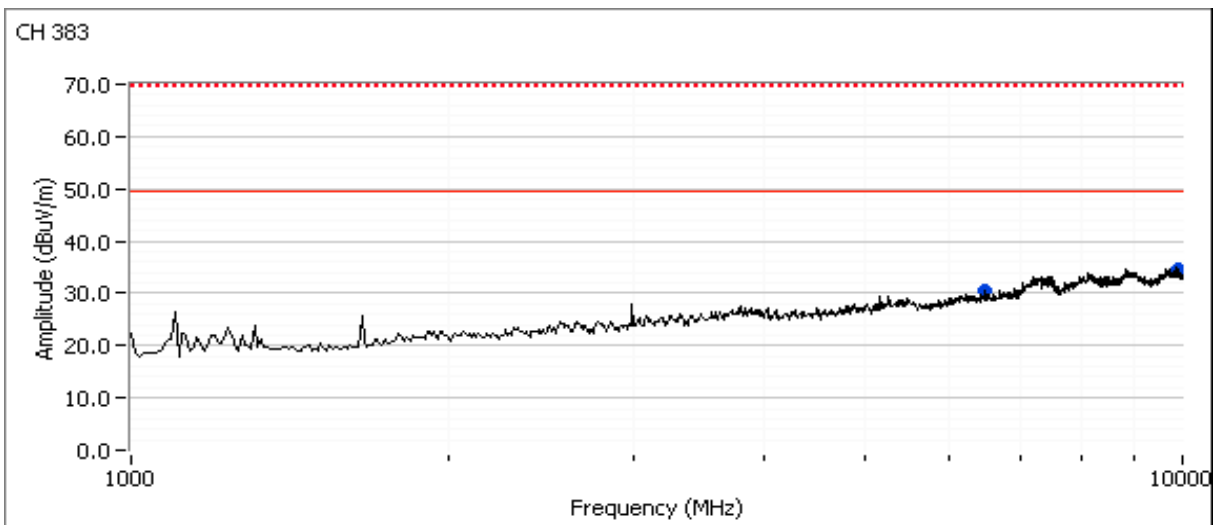
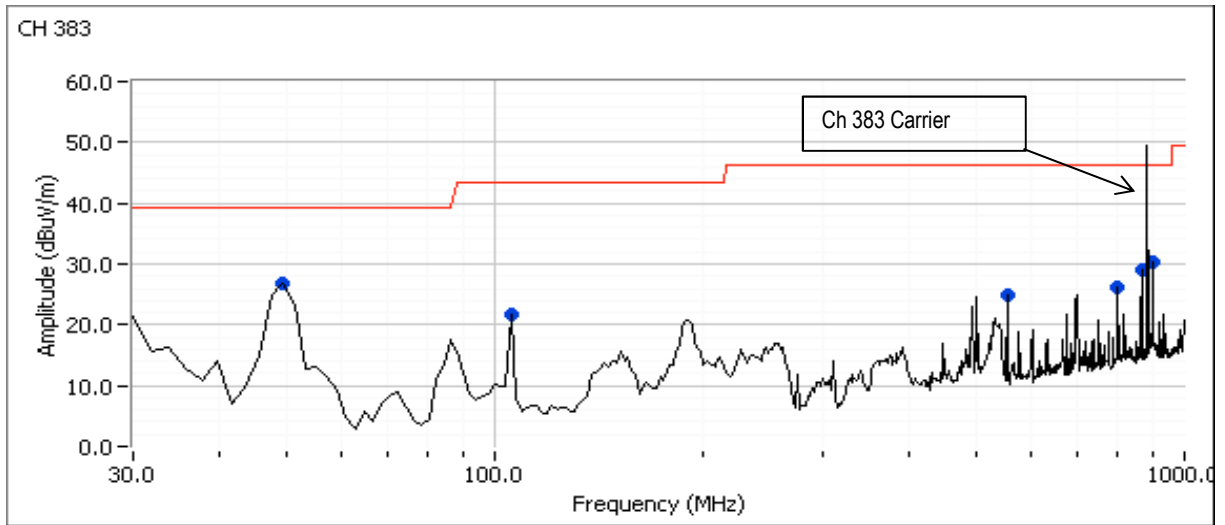

Note: FCC Part 15 Subpart B and ICES-003 Class A limits applied to show compliance with unintentional spurious emission limits

Client:	Star Solutions	Job Number:	J86373
Model Name:	iCell COMPAC 1X IP – RAN 800MHz CPU DC	T-Log Number:	T87071
Contact:	Azadeh Farzin [azadeh.farzin@starsolutions.com]	Account Manager:	Christine Krebill
Standard:	FCC Part 22 , RSS 129 Issue 2	Class:	N/A

Plots for high channel, Full Power

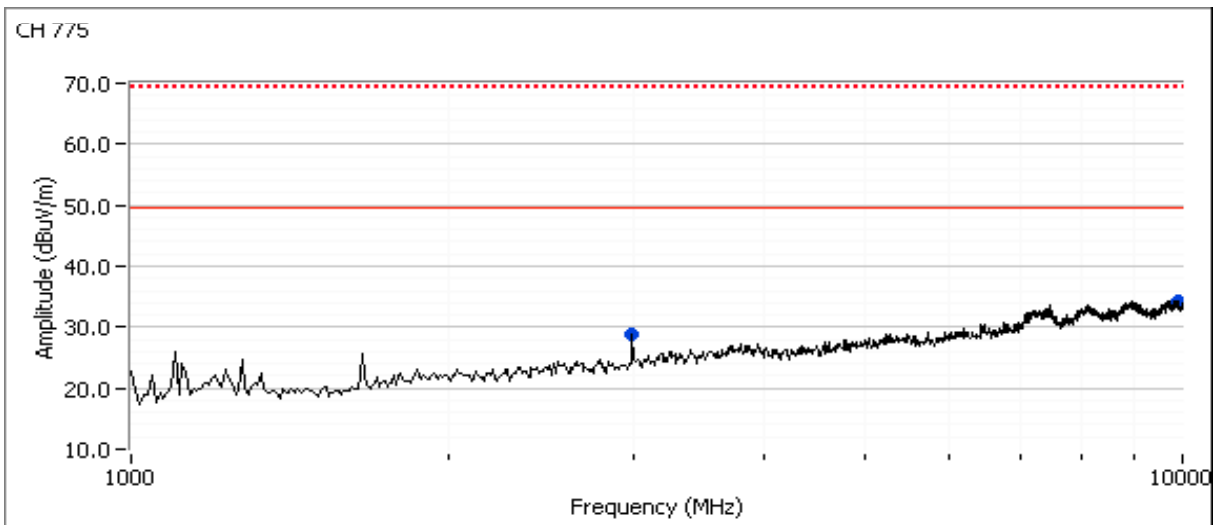
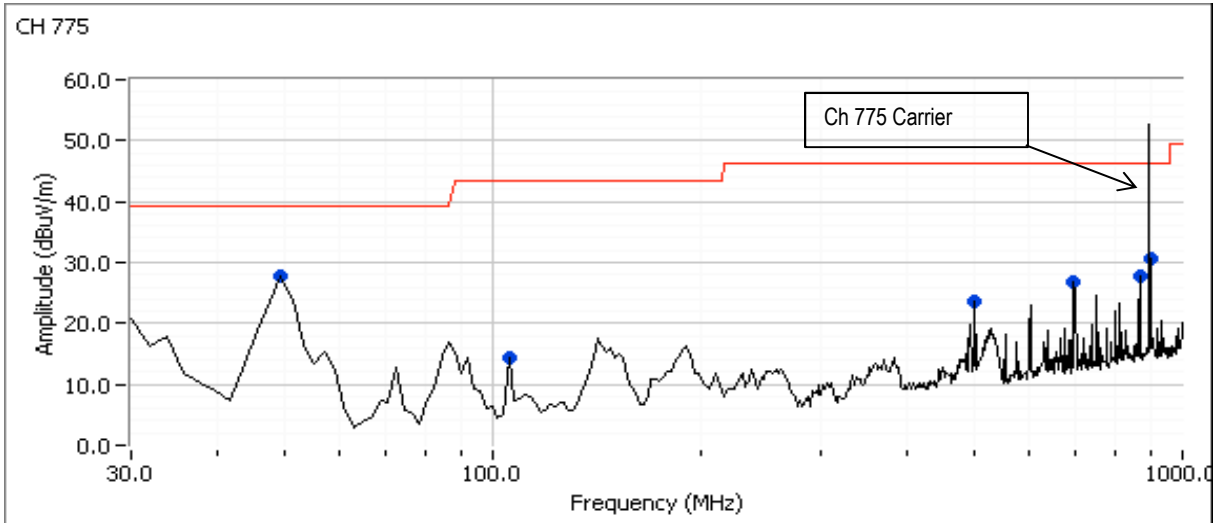

Note: FCC Part 15 Subpart B and ICES-003 Class A limits applied to show compliance with unintentional spurious emission limits



Radio Test Data

Client:	Star Solutions	Job Number:	J86373
Model Name:	iCell COMPAC 1X IP – RAN 800MHz CPU DC	T-Log Number:	T87071
		Account Manager:	Christine Krebill
Contact:	Azadeh Farzin [azadeh.farzin@starsolutions.com]		
Standard:	FCC Part 22 , RSS 129 Issue 2	Class:	N/A

Run #7: Out of Band Spurious Emissions, Radiated (Rx Mode)

Date of Test: 4/9/2012 0:00	Config. Used: 1
Test Engineer: Deniz	Config Change: None
Test Location: FT 5	EUT Voltage: -48 Vdc

Test Method:

The EUT was setup via a computer and Star Solutions software to transmit at maximum power in 1xRTT mode, at the low, middle, and high ends of the frequency bands supported. The EUT has no receive only mode

Requirement: all spurious emissions shall comply with the limits of theTable The resolution bandwidth of the spectrum analyser shall be 100 kHz for spurious emission measurements below 1.0 GHz and 1.0 MHz for measurements above 1.0 GHz.

Field Strenght Limits

Spurious Frequency (MHz)	Field Strength (microvolts/m) at 3 metres
30-88	100 (40 dBuV/m)
88-216	150 (43.5 dBuV/m)
216-960	200 (46 dBuV/m)
960-1610	500 (54 dBuV/m)
Above 1610	1000 (60 dBuV/m)

Test Result: Pass, The Tx spurious emissions are passing the Rx emission limits. See Out of Band Spurious Emissions, Radiated (TX Mode) results

End of Report

This page is intentionally blank and marks the last page of this test report.