

FCC TEST REPORT**FCC Rules Part 20.21****For:**

Mobile Communications, Inc
230 Earl Stewart Dr., Aurora, ON, Canada L4G6V8

FCC ID: S4RBRM22050


Report Type: Original Report	Product Type: Consumer wide-band bi-directional wireless booster
Test Engineer:	Roman Gurvich
Report Number:	BRM22050
Report Date:	Oct. 18, 2013
Prepared By: Roman Gurvich	Signature:  NAME: Roman Gurvich TITLE: RF Engineer

Table of Contents

1	GENERAL INFORMATION.....	4
1.1	Product Description Equipment Under Test (EUT).....	4
1.2	Mechanical Description.....	4
1.3	Objective.....	4
1.4	Test Methodology.....	4
1.5	Measurement Uncertainty.....	5
1.6	Test Facility.....	5
1.7	Test Equipment.....	5
2	Summary of Test Results.....	6
2.1	Rules Applied.....	6
2.2	Notes.....	6
3	Test Report.....	7
3.1	Part 20.21 § (e)(8)(i)(A) Noise Limits.....	7
3.1.1	Uplink noise power test procedure in the presence of a downlink signal.....	7
3.1.2	Downlink noise power test procedure in the presence of a downlink signal.....	8
3.1.3	Test results for noise power in presence of downlink signal.....	9
3.1.4	Maximum noise power test procedure.....	10
3.1.5	Maximum noise power test results.....	10
3.2	Part 20.21 § (e)(8)(i)(B) Bidirectional Capability.....	13
3.2.1	Bi-directional capability test procedure.....	13
3.2.2	Bi-directional capability test results.....	14
3.3	Part 20.21 § (e)(8)(i)(C) Booster Gain Limits.....	16
3.3.1	Variable booster gain test procedure.....	16
3.3.2	Variable booster gain test results.....	17
3.3.3	Maximum gain calculation procedure.....	17
3.3.4	Maximum gain test results.....	18
3.3.5	Variable uplink gain timing test procedure.....	18
3.3.6	Variable uplink gain timing test results.....	18
3.4	Part 20.21 § (e)(8)(i)(D) Power Limits.....	20
3.4.1	Maximum power measurement test procedure.....	20
3.4.2	Maximum power test results.....	21
3.4.3	AWGN Channel power test results.....	22
3.4.4	Pulsed CW power test results.....	24
3.5	Part 20.21 § (e)(8)(i)(E) Out of Band Emission Limits.....	26
3.5.1	Out of band emissions test procedure.....	27
3.5.2	Out of band emissions test results.....	28
3.5.3	Conducted spurious emissions test procedure.....	40
3.5.4	Conducted spurious emissions test results.....	41
3.6	Part 20.21 § (e)(8)(i)(F) Intermodulation Limits.....	45
3.6.1	Intermodulation product test procedure.....	45
3.6.2	Intermodulation product test results.....	46
3.7	Part 20.21 § (e)(8)(i)(G) Booster Antenna Kitting.....	48
3.8	Part 20.21 § (e)(8)(i)(H) Transmit Power Off Mode.....	50

3.9 Part 20.21 § (e)(8)(i)(I) Uplink Inactivity.....	51
3.9.1 Uplink inactivity test procedure.....	51
3.9.2 Uplink inactivity test results.....	52
3.10 Part 20.21 § (e)(8)(ii)(A) Anti-Oscillation.....	54
3.10.1 Anti-Oscillation test procedure.....	54
3.10.2 Test results.....	55
3.11 Part 20.21 § (e)(8)(ii)(B) Gain Control.....	59
3.12 Part 2.1049 Occupied Bandwidth.....	60
3.12.1 Occupied bandwidth test procedure.....	60
3.12.2 Occupied bandwidth Test Results.....	61
3.13 Part 2.1053 Radiated Spurious Emissions.....	69
3.13.1 Radiated spurious emissions test procedure.....	69
3.13.2 Radiated spurious emissions test results.....	69
4 MSCL Calculations & Measurements.....	70

1 GENERAL INFORMATION

1.1 Product Description Equipment Under Test (EUT)

This test and measurement report has been compiled by Mobile Communications, Inc. for product model number: BRM220-50
FCC ID: S4RBRM22050, which will be henceforth in this report to as the EUT (Equipment Under Test). The EUT is a Cellular/PCS Consumer wide-band bi-directional wireless booster.

EUT Description	Dual band, Bi-Directional Wireless Booster
FCC ID	S4RBRM22050
Operation Frequency	Cellular band: 824-849 MHz, 869-894 MHz PCS band: 1850-1910 MHz, 1930-1990 MHz
Modulations	CDMA, WCDMA, LTE, HSPA, GSM, GPRS, EDGE
Type of Equipment	Consumer wide-band bi-directional wireless booster

1.2 Mechanical Description

The EUT measures approximately 190 mm (L) x 90 mm (W) x 25 mm (H), and weighs approximately 350 grams.

1.3 Objective

This type approval report is prepared by Mobile Communications, Inc. in accordance with Part 20.21 of the Federal Communication Commissions rules.

The objective is to demonstrate compliance FCC rules.

1.4 Test Methodology

All tests and measurements indicated in this document were performed at Mobile Communications, Inc. in accordance with the Code of Federal Regulations Title 20.21.

The “Wideband Consumer Signal Booster Measurement Guidance” draft, KDB publication # 935210 D03, was used in test procedure to test EUT.

1.5 Measurement Uncertainty

All measurements involve certain level of uncertainties, especially in the field of EMC. The factors contributing to uncertainties are spectrum analyzer, cable loss, antenna factor calibration and antenna directivity, antenna factor variation with height, antenna phase centre variation, antenna factor frequency interpolation, measurement distance variation, site imperfections, mismatch (average), and system repeatability.

Based on NIS81, The Treatment of Uncertainty in EMC Measurements, the values ranging from ± 2.0 dB for Conducted Emissions tests and ± 4.0 dB for Radiated Emissions tests are the most accurate estimates pertaining to uncertainty of EMC measurements at Mobile Communications, Inc.

1.6 Test Facility

The test conducted at Mobile Communications, Inc. located at 230 Earl Stewart Drive, Aurora, Ontario, Canada, L4G6V8. Conducted emissions measurement data collected and presented in this report.

1.7 Test Equipment

#	Description	Manufacturer	Model No	Serial No	Calibration Date
1	Spectrum Analyzer	Agilent	E4440A	MY46186564	7/16/2013
2	Signal Generator #1	Agilent	E4438C	US41461477	7/12/2013
3	Signal Generator #2	Agilent	E4438C	US41461389	6/25/2013
3	Power Supply	Instek	GPC-3030	9640185	N/A
4	Bi-Directional Coupler	Minicircuits	ZABDC10-25HP	N/A	N/A
5	Bi-Directional Coupler	Minicircuits	ZFBDC20-900HP	N/A	N/A
6	Variable RF Attenuator	Weinschel	905	5396	N/A
7	Fixed RF Attenuator	Weinschel	5W-20	N/A	N/A
8	RF Test Cables	Smoothtalker	SEMRC205	N/A	N/A

2 Summary of Test Results

2.1 Rules Applied

FCC Rules	Description of Tests	Results
§ 20.21 (e)(8)(i)(A)	Noise Limits	Comply
§ 20.21 (e)(8)(i)(B)	Bidirectional Capability	Comply
§ 20.21 (e)(8)(i)(C)	Booster Gain Limits	Comply
§ 20.21 (e)(8)(i)(D)	Power Limits	Comply
§ 20.21 (e)(8)(i)(E)	Out of Band Emission Limits	Comply
§ 20.21 (e)(8)(i)(F)	Intermodulation Limits	Comply
§ 20.21 (e)(8)(i)(G)	Booster Antenna Kitting	Note i
§ 20.21 (e)(8)(i)(H)	Transmit Power OFF Mode	Comply
§ 20.21 (e)(8)(i)(I)	Uplink Inactivity	Comply
§ 20.21 (e)(8)(ii)(A)	Anti-Oscillation	Comply
§ 20.21 (e)(8)(ii)(B)	Gain Control	Comply
§ 20.21 (e)(8)(ii)(C)	Interference Avoidance for Wireless Subsystems	Note ii
§ 2.1049	Occupied Bandwidth	Comply

2.2 Notes

i) EUT user manual specifies all antennas and cables to be used. All technical documentation provided with the application for FCC equipment authorization that shows compliance of all antennas, cables and/or coupling devices with the requirements of this section.

ii) Does not apply to EUT

3 Test Report

3.1 Part 20.21 § (e)(8)(i)(A) Noise Limits.

(1) The transmitted noise power in dBm/MHz of consumer boosters at their uplink and downlink ports shall not exceed -103 dBm/MHz - RSSI. Where RSSI (received signal strength indication) is the downlink composite received signal power in dBm at the booster donor port for all base stations in the band of operation. RSSI is expressed in negative dB units relative to 1 mW.

3.1.1 Uplink noise power test procedure in the presence of a downlink signal

(Reference: KDB #935210 D03, § 7.7)

- A. *Connect the EUT to the test equipment as shown in Figure 2 for uplink and Figure 3 for downlink. Ensure the coupled path of the RF coupler is connected to the spectrum analyzer.*
- B. *Configure the signal generator for 4.1 MHz AWGN operation for uplink test and 200 kHz 99% OBW AWGN for downlink test.*
- C. *Set the spectrum analyzer RBW for 1 MHz with the VBW $\geq 3X$ the RBW with an RMS AVERAGE detector with at least 100 traces averages.*
- D. *Set the center frequency of the spectrum analyzer to the center of the CMRS band under test with the span $\geq 2X$ the CMRS band. This shall include all spectrum blocks in the particular CMRS band under test (see Annex A). For uplink noise measurements, set the spectrum analyzer center frequency for the uplink band under test and tune the signal generator to the center of the paired downlink band. For downlink noise measurements, set the spectrum analyzer to the center of the downlink band and tune the signal generator to the upper or lower band-edge of the same band, ensuring that the maximum noise power is being measured.*
- E. *Measure the maximum Transmitter Noise Power Level when varying the downlink signal generator level from -90 to -10 dBm in 1 dB steps inside the RSSI dependent region and 10 dB steps outside the RSSI dependent region, report the six values closest to the limit with at least 2 points within the RSSI dependent region of the limit.*
- F. *Repeat A through E for all operational uplink and downlink bands.*

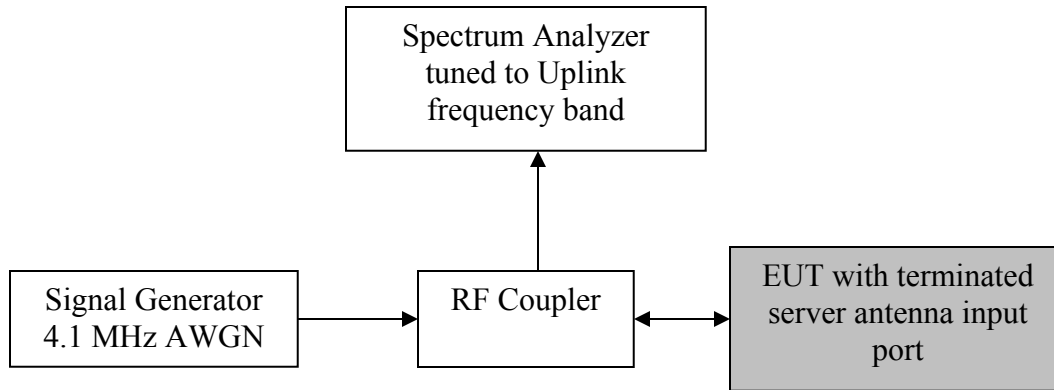


Figure 2: Test setup for uplink noise power measurement in the presence of a downlink signal

3.1.2 Downlink noise power test procedure in the presence of a downlink signal

- A. Set the spectrum analyzer to the uplink frequency to be measured.
- B. Set the span to 0 Hz with a sweep time of 10 seconds.
- X. Set the power level of signal generator 1 to the lowest level of the RSSI dependent noise.
- Δ. Select MAX HOLD and increase the power level of signal generator 1 by 10 dB for mobile boosters and 20 dB for fixed boosters.
- E. Ensure that the Uplink noise decrease to the specified levels within 1 second for mobile devices and 3 seconds for fixed devices.
- Φ. Repeat steps A to E for all operational uplink bands.

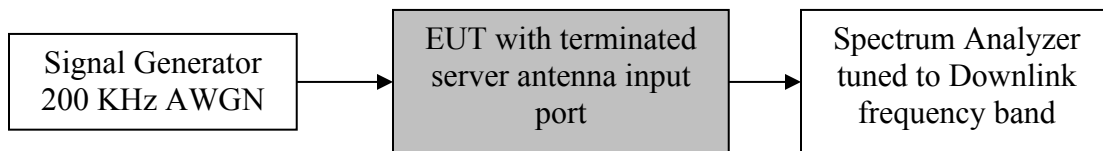


Figure 3: Test setup downlink noise power measurement in the presence of a downlink signal

3.1.3 Test results for noise power in presence of downlink signal

Table 1: 800 MHz Uplink and downlink noise power in the presence of a downlink signal

Noise Limits 800 MHz			
RSSI (dBm)	Maximum Allowed (dBm/MHz)	Measured Uplink Noise (dBm/MHz)	Measured Downlink Noise (dBm/MHz)
-90	-59	-59.6	-60.9
-80	-59	-59.7	-60.8
-70	-59	-60.2	-60.2
-60	-59	-59.9	-60.8
-55	-59	-59.3	-60.2
-50	-59	-59.9	-65.7
-45	-59	-59.9	-71.3

Table 2: 1900 MHz Uplink and downlink noise power in the presence of a downlink signal

Noise Limits 1900 MHz			
RSSI (dBm)	Maximum Allowed (dBm/MHz)	Measured Uplink Noise (dBm/MHz)	Measured Downlink Noise (dBm/MHz)
-90	-59	-59.6	-59.1
-80	-59	-60.2	-59.5
-70	-59	-60.1	-59.2
-60	-59	-59.6	-59.3
-55	-59	-60.0	-60.0
-50	-59	-60.1	-65.6
-45	-59	-60.3	-69.5

(2) The transmitted maximum noise power in dBm/MHz of consumer boosters at their uplink and downlink ports shall not exceed the following limits:

(ii) Mobile booster maximum noise power shall not exceed -59 dBm/MHz.

3.1.4 Maximum noise power test procedure

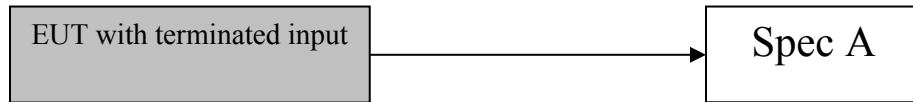


Figure 1: Noise limit instrumentation setup

- A. Connect the EUT to the test equipment as shown in Figure 1. Begin with the uplink output connected to the spectrum analyzer.
- B. Set the spectrum analyzer RBW to 1 MHz with the VBW ≥ 3X RBW
- C. Select the power averaging (RMS) detector and trace average over at least 100 traces.
- D. Set the center frequency of the spectrum analyzer to the center of the CMRS band under test with the span ≥ 2X the CMRS band.
- E. Measure the maximum Transmitter Noise Power Level.
- F. Save the spectrum analyzer plot as necessary for inclusion in the final test report.
- G. Repeat steps A to F above for all operational uplink and downlink bands.

3.1.5 Maximum noise power test results

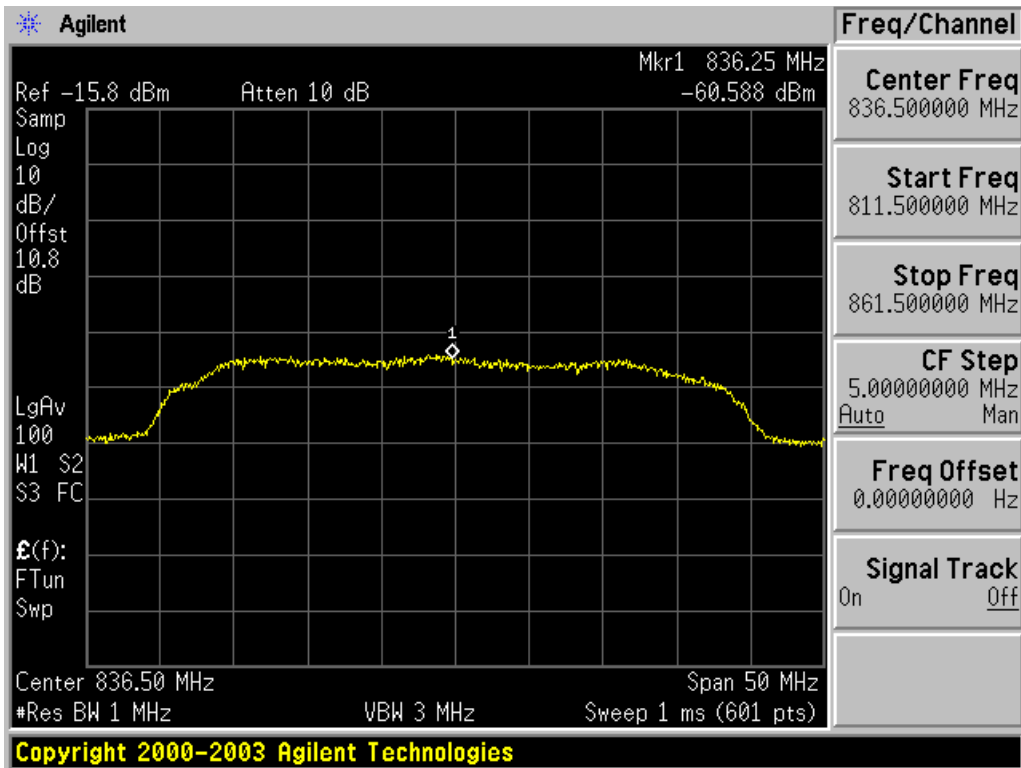
Spectrum Analyzer screenshots for EUT with terminated input ports. Output port connected to Spectrum Analyzer.

Table 3: Fixed booster maximum noise for band 5 (cellular) shell not exceed
 $-102 \text{ dBm/MHz} + 20 * \text{LOG10}(836.5 \text{ MHz}) = -44.1 \text{ dBm/MHz}$
 For band 2 (PCS) shell not exceed
 $-102 \text{ dBm/MHz} + 20 * \text{LOG10}(1880 \text{ MHz}) = -37.0 \text{ dBm/MHz}$

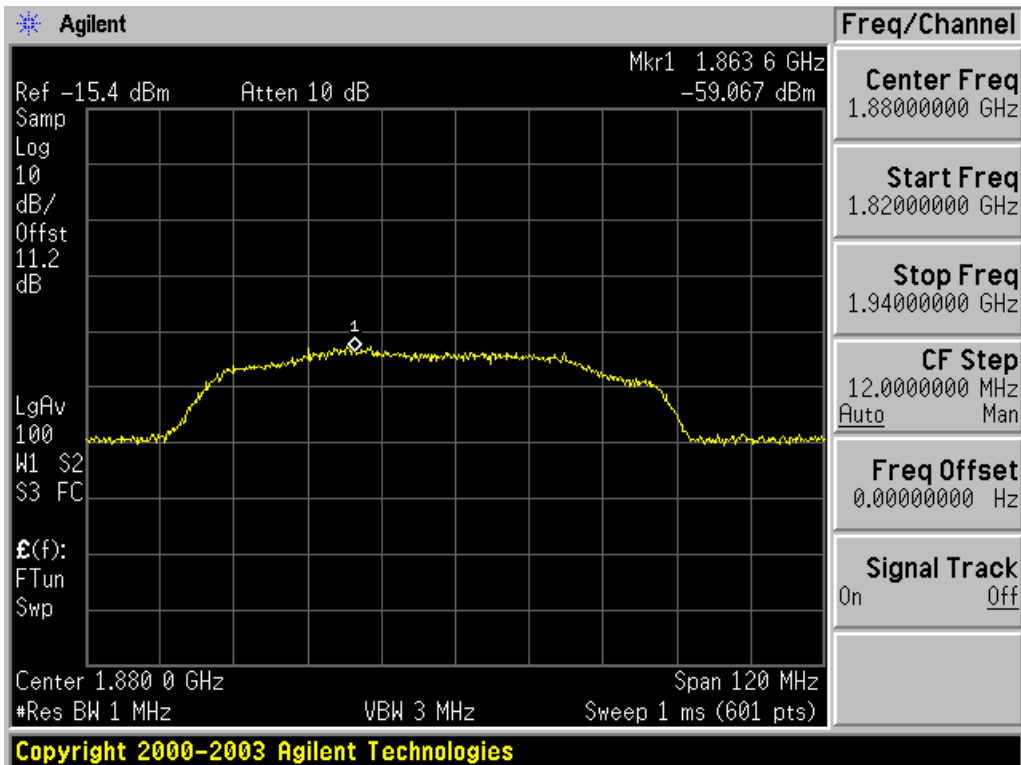
Fixed Booster Maximum Noise			
Frequency Band	Permitted Max Noise (dBm/MHz)	Measured Noise (dBm/MHz)	Result
800 MHz Uplink	-44.1	-60.6	Pass
800 MHz Downlink	-44.1	-59.6	Pass
1900 MHz Uplink	-37.0	-59.1	Pass
1900 MHz Downlink	-37.0	-59.6	Pass

Table 4: Mobile booster maximum noise power

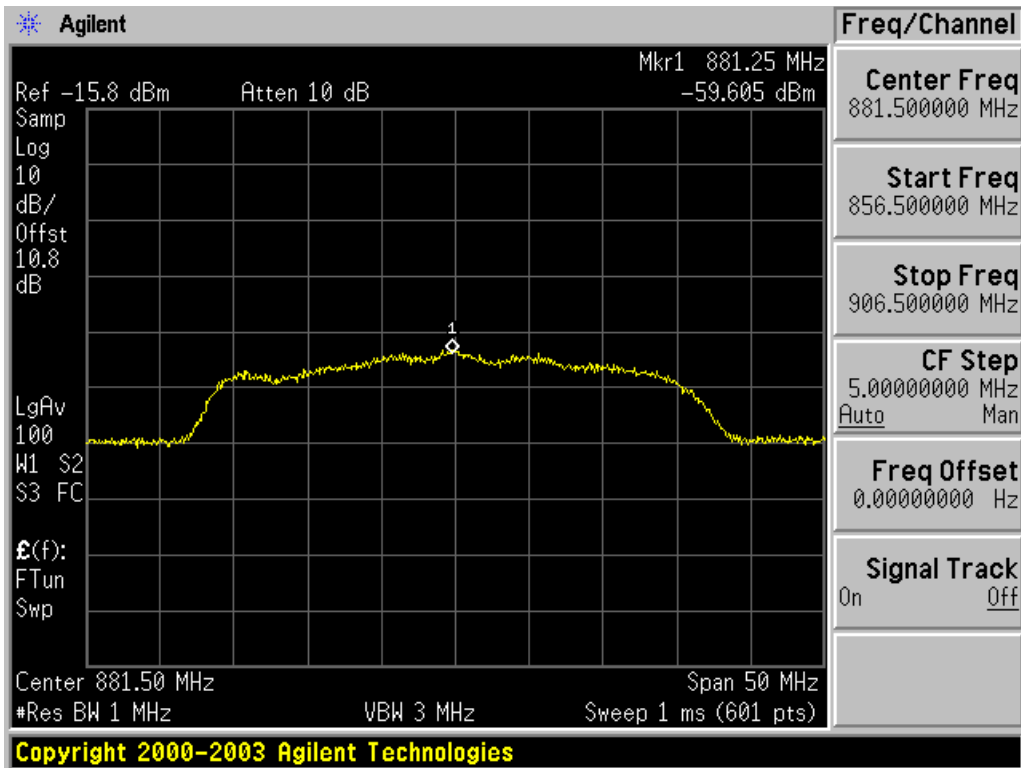
Mobile Booster Maximum Noise			
Frequency Band	Permitted Max Noise (dBm/MHz)	Measured Noise (dBm/MHz)	Result
800 MHz Uplink	-59.0	-60.6	Pass
800 MHz Downlink	-59.0	-59.6	Pass
1900 MHz Uplink	-59.0	-59.1	Pass
1900 MHz Downlink	-59.0	-59.6	Pass



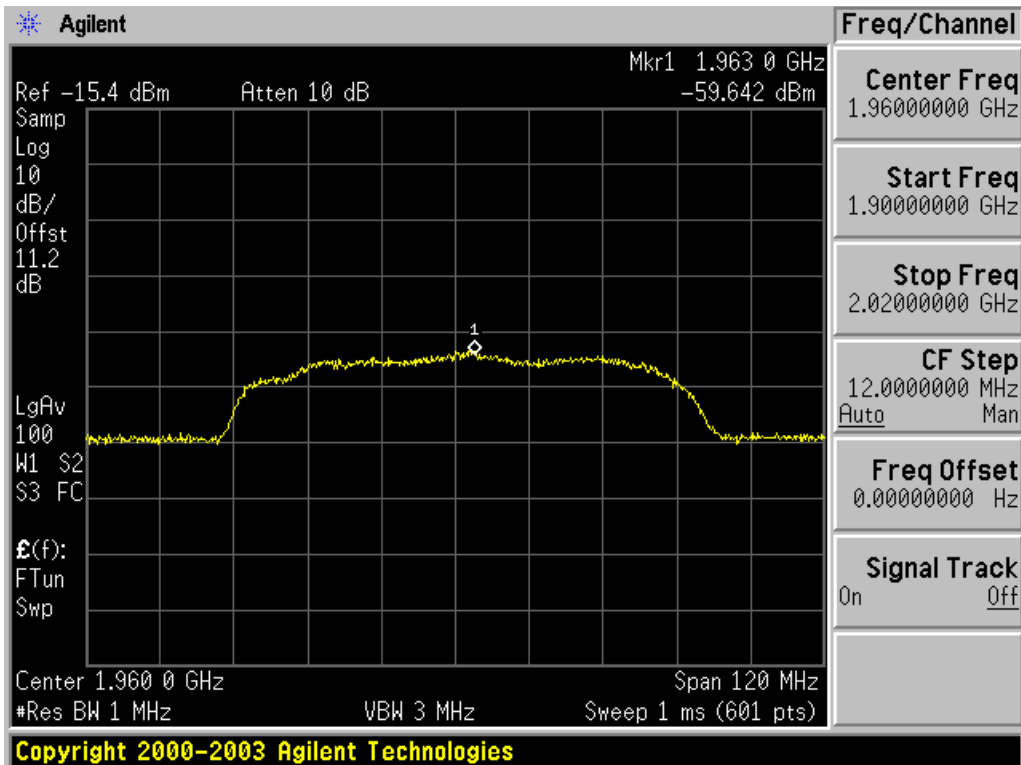
Uplink 800 MHz operational band



Uplink 1900 MHz operational band



Downlink 800 MHz operational band



Downlink 1900 MHz operational band

3.2 Part 20.21 § (e)(8)(i)(B) Bidirectional Capability.

Consumer Boosters must be able to provide equivalent uplink and downlink gain and conducted uplink power output that is at least 0.05 watts.

One-way consumer boosters (i.e., uplink only, downlink only, uplink impaired, downlink impaired) are prohibited.

3.2.1 Bi-directional capability test procedure

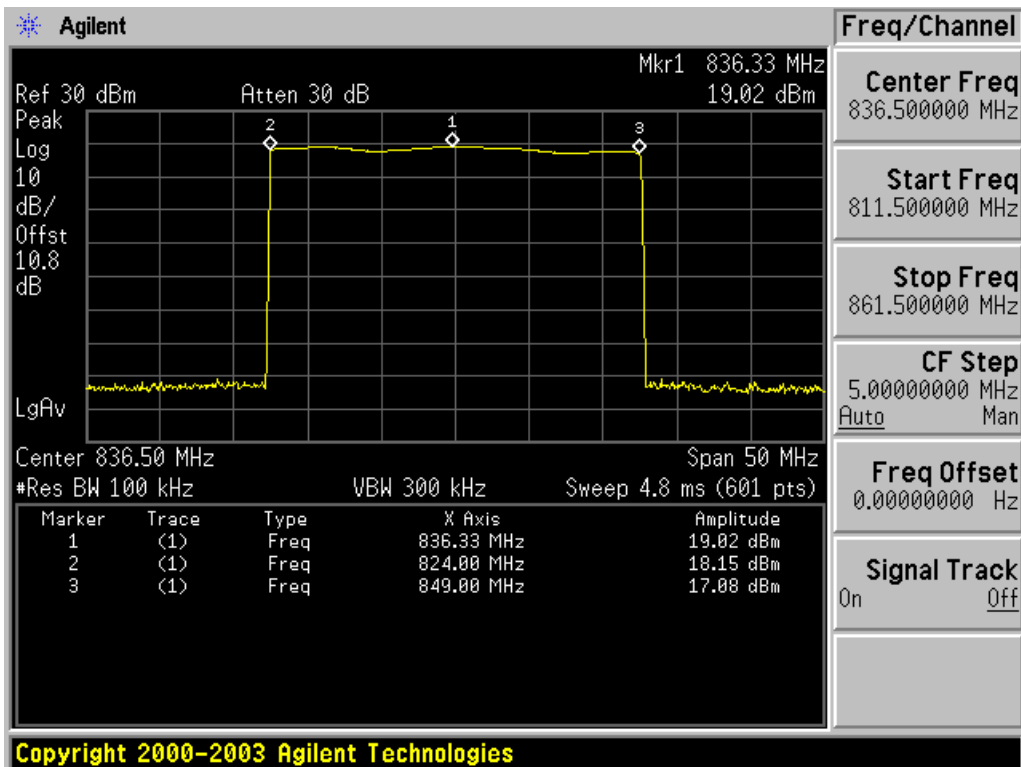
(Reference: KDB #935210 D03, § 7.2 and § 7.3)

- A. Connect the EUT to the test equipment as shown in Figure 4. Begin with the uplink output connected to the spectrum analyzer.
- B. Set the spectrum analyzer RBW for 100 kHz with the VBW $\geq 3X$ the RBW using a PEAK detector with the MAX HOLD function.
- C. Set the center frequency of the spectrum analyzer to the center of the operational band under test with a span of 1 MHz.
- D. Set the signal generator for CW mode and tune to the center frequency of the operational band under test.
- E. Set the signal generator power to a level just below the AGC level without triggering the AGC.
- F. Reset the spectrum analyzer span to 2 X the CMRS band under test. Adjust the tuned frequency of the signal generator to sweep 2 times the CMRS band using the sweep function. Note: The AGC must not be activated throughout entire sweep.
- G. Using three markers identify the CMRS band edges and the frequency with the highest power. Ensure that the values of all markers are visible on the display of the spectrum analyzer (e.g., marker table set to on).
- H. Capture the spectrum analyzer trace for inclusion in the test report.
- I. Repeat steps C to H for all operational uplink and downlink bands.

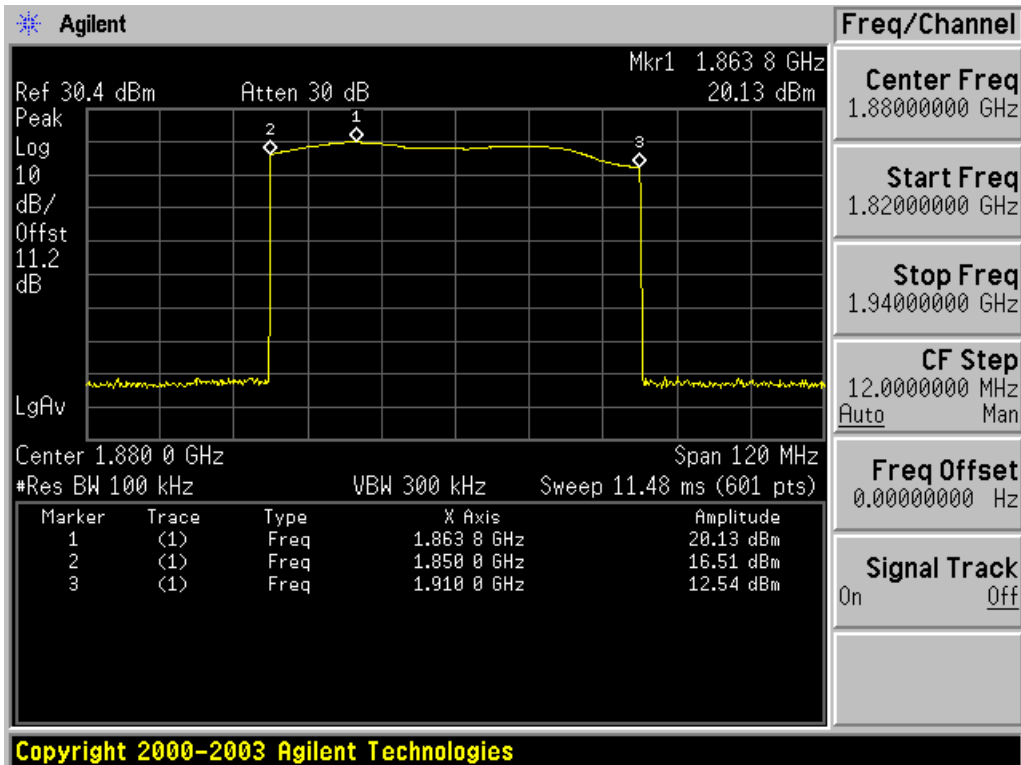


Figure 4

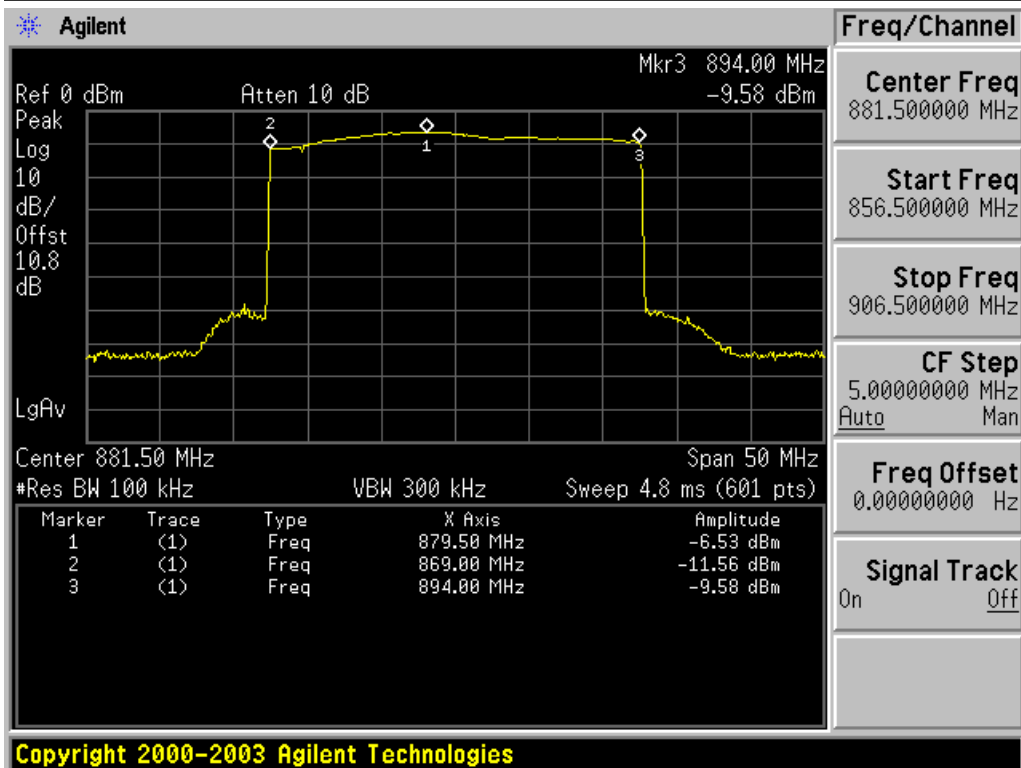
3.2.2 Bi-directional capability test results



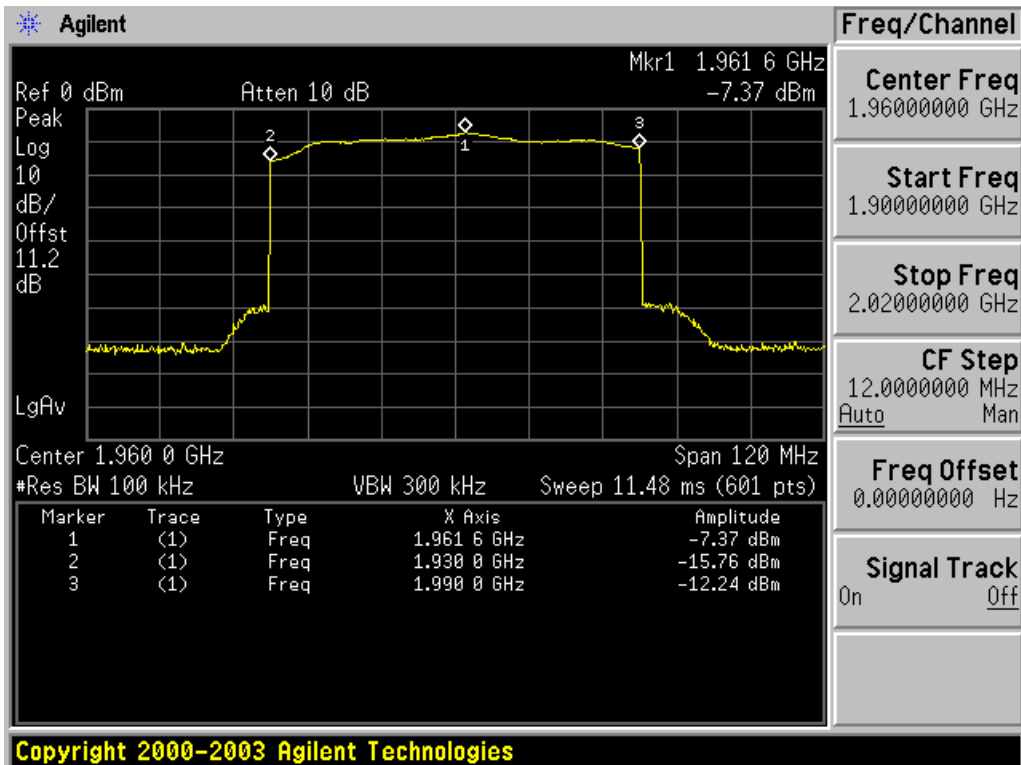
Uplink 800 MHz band



Uplink 1900 MHz band



Downlink 800 MHz band



Downlink 1900 MHz band

3.3 Part 20.21 § (e)(8)(i)(C) Booster Gain Limits.

(1) The uplink gain in dB of a consumer booster referenced to its input and output ports shall not exceed $-34 \text{ dB} - \text{RSSI} + \text{MSCL}$.

(i) Where RSSI is the downlink composite received signal power in dBm at the booster donor port for all base stations in the band of operation. RSSI is expressed in negative dB units relative to 1 mW.

(ii) Where MSCL (Mobile Station Coupling Loss) is the minimum coupling loss in dB between the wireless device and input port of the consumer booster. MSCL must be calculated or measured for each band of operation and provided in compliance test reports.

3.3.1 Variable booster gain test procedure

(Reference: KDB #935210 D03, § 7.3 and § 7.9)

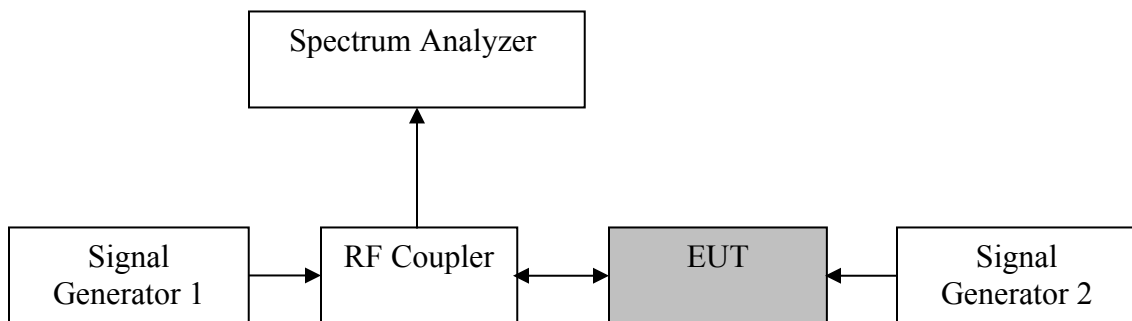


Figure 5: Variable uplink gain test setup

- A. Connect the EUT to the test equipment as shown in Figure 5 with the uplink output connected to signal generator 1. Ensure the coupled path of the RF coupler is connected to the spectrum analyzer.
- B. Configure downlink signal generator #1 for AWGN operation with 99% occupied bandwidth of 4.1 MHz tuned to the center of the downlink operational band.
- C. Set the power level and frequency of signal generator # 2 to a value 0.5 dB below the AGC level from section 3.4. The signal type is AWGN with a 99% OBW of 4.1 MHz.
- D. Set span to at least 10 MHz.
- E. Set RBW = 100 kHz and VBW \geq 300 kHz.
- F. Select the CHANNEL POWER measurement tool.
- G. Select the RMS (power averaging) detector.
- H. Ensure that the number of measurement points per sweep $\geq (2 \times \text{span})/\text{RBW}$.
- I. Sweep time = auto couple or as necessary.
- J. Trace average at least 10 traces in power averaging (i.e., RMS) mode.
- K. Measure the maximum channel power and compute maximum gain when varying the signal generator 1 to a level from -90 to -10 dBm in 1 dB steps inside the RSSI dependent region and 10 dB steps outside the RSSI dependent region and report the six values closest to the limit, including at least two points from within the RSSI dependent region of operation.
- L. Repeat A to K for all operational uplink bands.

3.3.2 Variable booster gain test results

Table 4: Variable booster gain

Uplink Variable Gain 836.5 MHz					
RSSI (dBm)	MSCL (dB)	P in (dBm)	P out (dBm)	Gain	Maximum Permitted Gain (dB)
-90	30	-25	18.7	43.7	50
-80	30	-25	18.6	43.6	50
-70	30	-25	18.7	43.7	50
-60	30	-25	18.6	43.6	50
-55	30	-25	18.6	43.6	50
-50	30	-25	13.8	38.8	46
-45	30	-25	8.9	33.9	41
Uplink Variable Gain 1864 MHz					
RSSI (dBm)	MSCL (dB)	P in (dBm)	P out (dBm)	Gain	Maximum Permitted Gain (dB)
-90	30	-26	17.9	43.9	50
-80	30	-26	17.9	43.9	50
-70	30	-26	18.0	44.0	50
-60	30	-26	18.0	44.0	50
-55	30	-26	17.9	43.9	50
-50	30	-26	13.3	39.3	46
-45	30	-26	8.5	34.5	41

(2) The uplink and downlink maximum gain of a Consumer Booster referenced to its input and output ports shall not exceed the following limits:

(iii) Mobile Booster maximum gain shall not exceed 50 dB when using an inside antenna (e.g., inside a vehicle), 23 dB when using direct contact coupling (e.g., cradle-type boosters), or 15 dB when directly connected (e.g., boosters with a physical connection to the phone).

3.3.3 Maximum gain calculation procedure

- A. Calculate the maximum gain of the booster based on measurements obtained from Bi-Directional Capability test.
- B. For both the uplink and downlink in each supported frequency band, use each of the Pout and Pin value pairs determined in bi-directional capability test in the following equation to determine the maximum gain (G) of the booster:

$$G (dB) = Pout (dBm) - Pin (dBm).$$
- C. Record the maximum gain of the uplink and downlink paths for each supported frequency band and verify that the each gain value complies with the applicable limit.

3.3.4 Maximum gain test results

Table 6: Fixed booster maximum gain for band 5 (cellular) shall not exceed

$$6.5 \text{ dB} + 20 * \text{LOG10}(836.5 \text{ MHz}) = 64.9 \text{ dB}$$

For band 2 (PCS) shall not exceed

$$6.5 \text{ dB} + 20 * \text{LOG10}(836.5 \text{ MHz}) = 72 \text{ dB}$$

Operational Band	P in (dBm)	P out (dBm)	Gain (dB)	Rules	Result
800 MHz Uplink	-26.1	19.0	45.1	64.9	Pass
800 MHz Downlink	-56.3	-6.5	49.8	64.9	Pass
1900 MHz Uplink	-25.1	20.1	45.2	72	Pass
1900 MHz Downlink	-57.1	-7.4	49.7	72	Pass

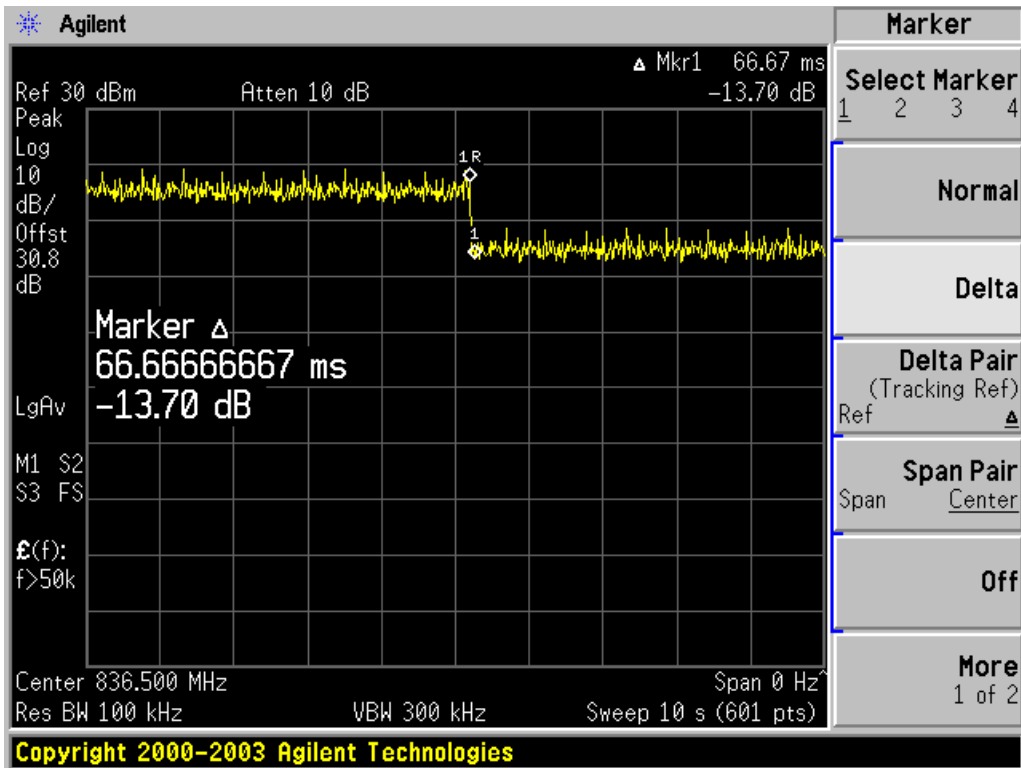
Table 7: Maximum mobile booster gain

Operational Band	P in (dBm)	P out (dBm)	Gain (dB)	Rules	Result
800 MHz Uplink	-26.1	19.0	45.1	50	Pass
800 MHz Downlink	-56.3	-6.5	49.8	50	Pass
1900 MHz Uplink	-25.1	20.1	45.2	50	Pass
1900 MHz Downlink	-57.1	-7.4	49.7	50	Pass

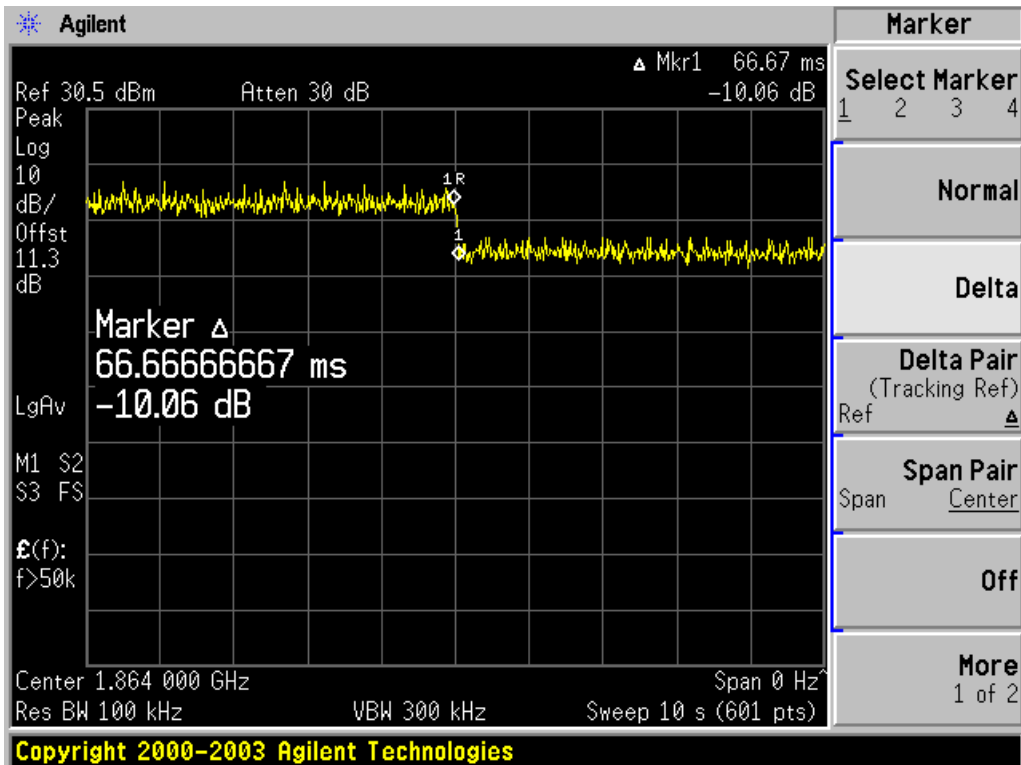
3.3.5 Variable uplink gain timing test procedure

- A. Set the spectrum analyzer to the uplink frequency to be measured.
- B. Set the span to 0 Hz with a sweep time of 10 seconds.
- C. Set the power level of signal generator 1 to the lowest level of the RSSI dependent gain.
- D. Select MAX HOLD and increase the power level of signal generator 1 by 10 dB for mobile booster and 20 dB for fixed indoor boosters.
- E. Ensure that the Uplink gain decrease to the specified levels within 1 second for mobile devices and 3 seconds for fixed devices.
- F. Repeat A to E for all operational uplink bands.

3.3.6 Variable uplink gain timing test results



Uplink 832.4 MHz band variable gain timing



Uplink 1900 MHz band variable gain timing

3.4 Part 20.21 § (e)(8)(i)(D) Power Limits.

A booster's uplink power must not exceed 1 watt composite conducted power and equivalent isotropic radiated power (EIRP) for each band of operation. Composite downlink power shall not exceed 0.05 watt (17 dBm) conducted and EIRP for each band of operation. Compliance with power limits will use instrumentation calibrated in terms of RMS equivalent voltage.

3.4.1 Maximum power measurement test procedure

(Reference: KDB #935210 D03, § 7.2)



Figure 6

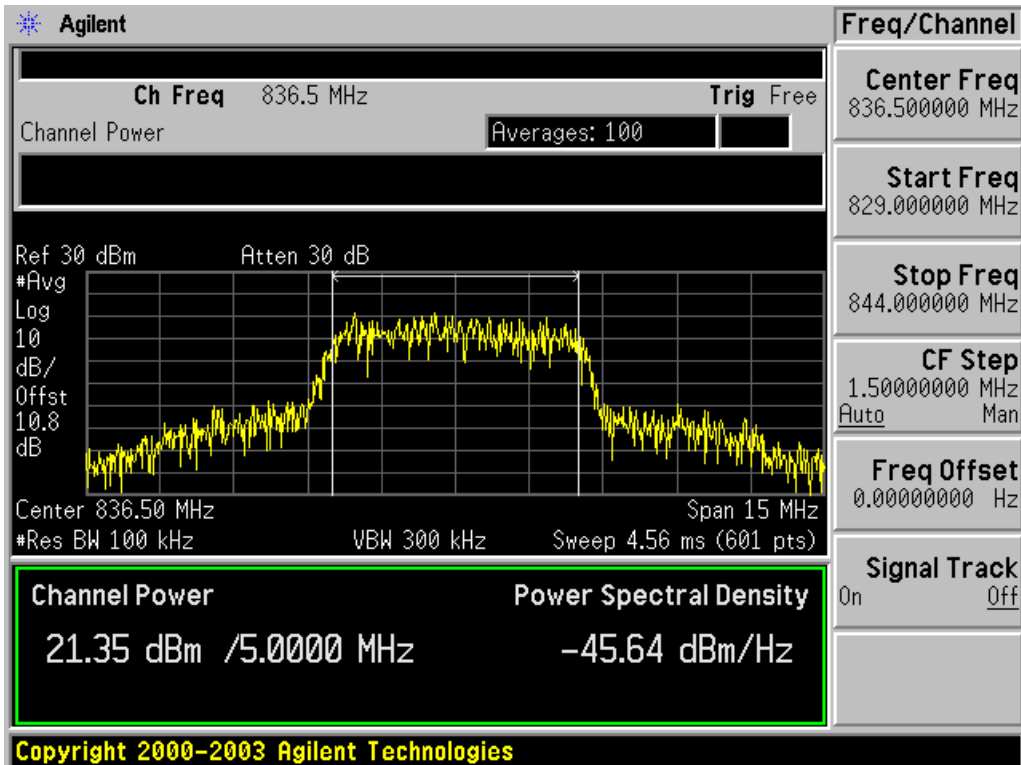
- A. Connect the EUT to the test equipment as shown in figure 6. Begin with the uplink output (donor port) connected to the spectrum analyzer.
- B. Configure the signal generator and spectrum analyzer for operation on the frequency determined in test 3.2 of the highest power level, but with the center frequency of the signal no closer than 2.5 MHz from the band edge. The spectrum analyzer span shall be set to at least 10 MHz.
- C. Configure signal generator to create an AWGN signal with a 99% Occupied Bandwidth of 4.1 MHz
- D. Set the initial signal generator power to a level just below (within 0.5 dB of) the AGC limit without triggering the AGC. Note the signal generator power level as (P_{in}).
- E. Measure the output power (P_{out}) with the spectrum analyzer as follows.
- F. Set $RBW = 100$ kHz and $VBW \geq 300$ kHz.
- G. Use the CHANNEL POWER measurement tool, as required for this signal type.
- H. Ensure that the number of measurement points per sweep $\geq (2 \times \text{span})/RBW$
- I. Set sweep time = auto couple, or as necessary.
- J. Set trace average at least 100 traces in power averaging mode.
- K. Record the measured power level as P_{out} .
- L. Repeat the procedure A to K for each operational uplink and downlink frequency band supported by the booster.
- M. Select the RMS (power averaging) detector..
- N. Ensure that the number of measurement points per sweep $\geq (2 \times \text{span})/RBW$ (Note: This requirement does not apply for BURST power measurement mode).
- O. Set sweep time = auto couple, or as necessary.
- P. Trace average at least 100 traces in power averaging (i.e., RMS) mode.
- Q. Record the measured power level as $POUT$.
- R. Repeat the procedure for each operational uplink and downlink frequency band supported by the booster.

3.4.2 Maximum power test results

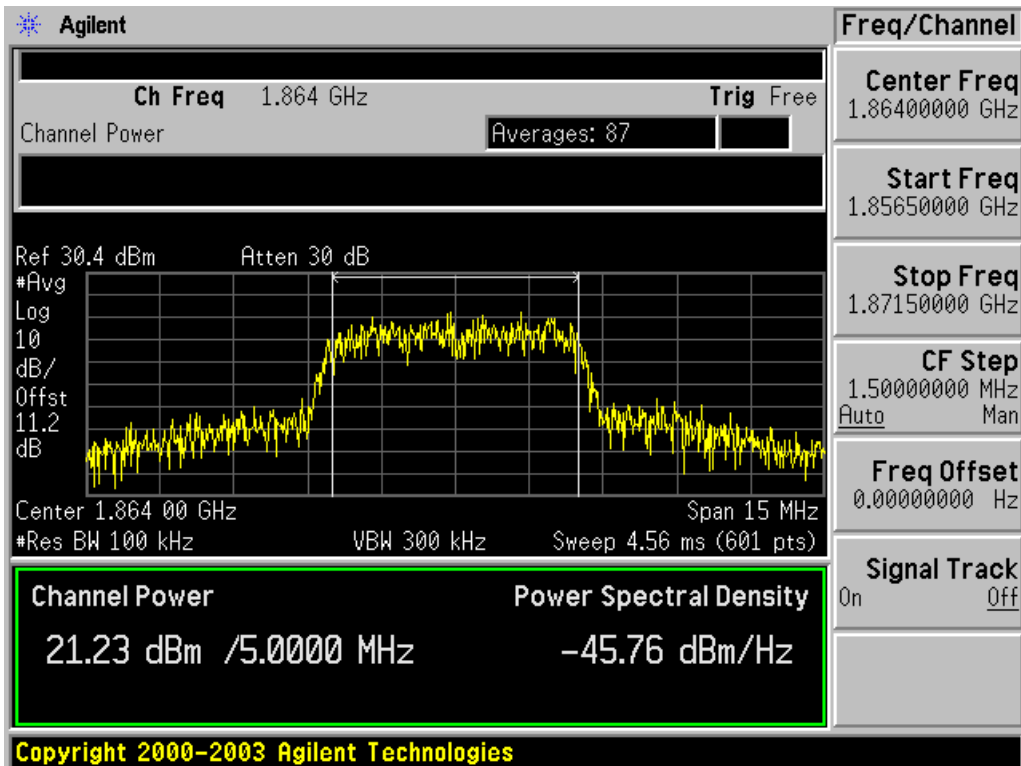
Table 8:

Uplink Band	Freq (MHz)	Conducted Power (dBm)	Minimum requirement (dBm)	EIRP calculated using highest authorized outside antenna gain (7.14dBi)	Max limit	Result
800 MHz AWGN	836.5	21.35	17	0.704 watts	1 watt	Pass
800 MHz Pulsed CW	836.5	21.34	17	0.704 watts	1 watt	Pass
1900 MHz AWGN	1864	21.23	17	0.690 watts	1 watt	Pass
1900 MHz Pulsed CW	1864	21.31	17	0.700 watts	1 watt	Pass
Downlink Band	Freq (MHz)	Conducted Power (dBm)	Maximum requirement (dBm)	EIRP calculated using highest authorized server antenna gain (2.1dBi)	Max limit	Result
800 MHz AWGN	879.5	-4.01	17	0.00065 watts	0.05 watt	Pass
800 MHz Pulsed CW	879.5	-3.95	17	0.00065 watts	0.05 watt	Pass
1900 MHz AWGN	1961.5	-5.17	17	0.00050 watts	0.05 watt	Pass
1900 MHz Pulsed CW	1961.5	-5.34	17	0.00050 watts	0.05 watt	Pass

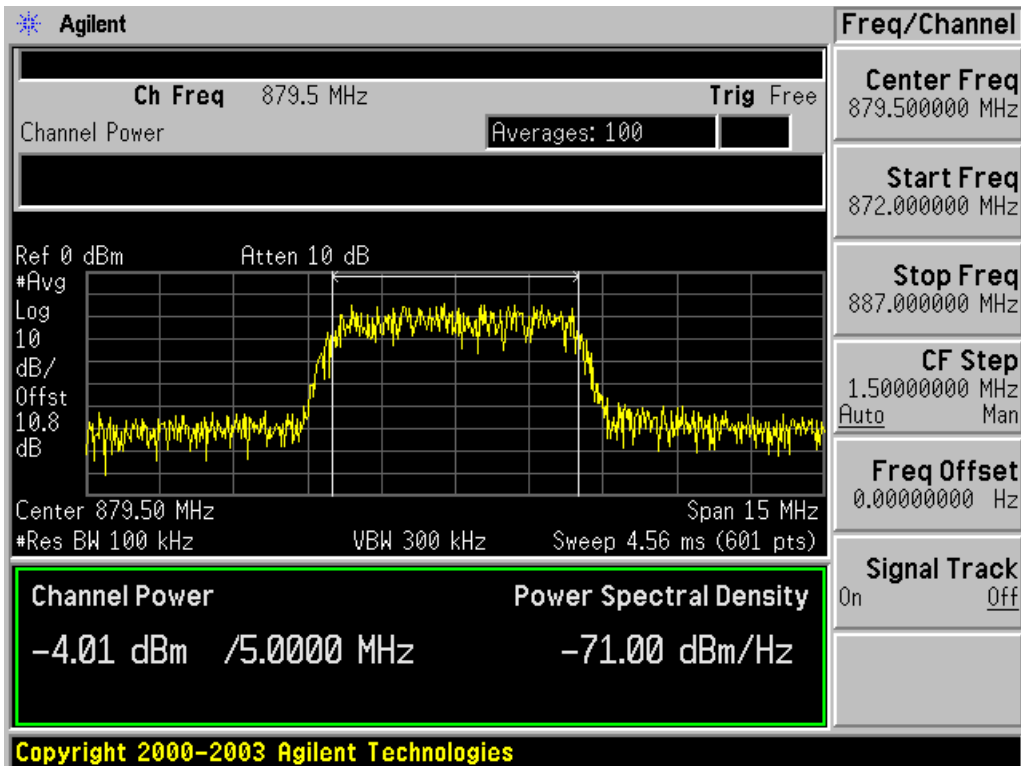
3.4.3 AWGN Channel power test results



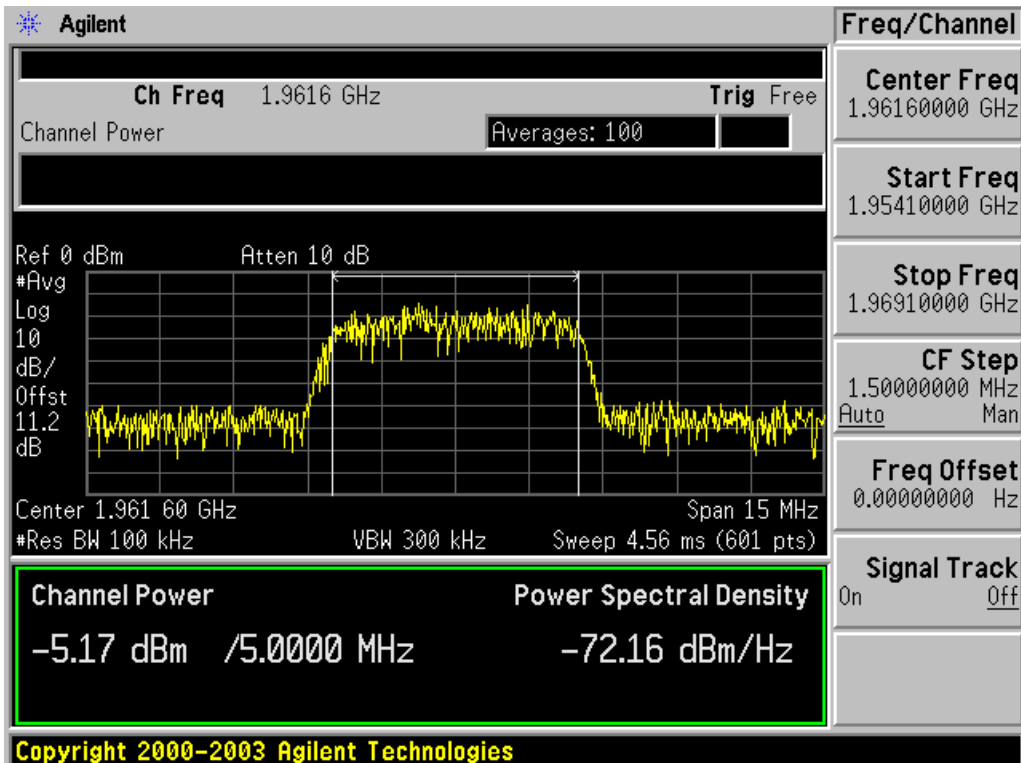
Uplink 836.5MHz AWGN Channel Power Limit



Uplink 1864 MHz AWGN Channel Power Limit

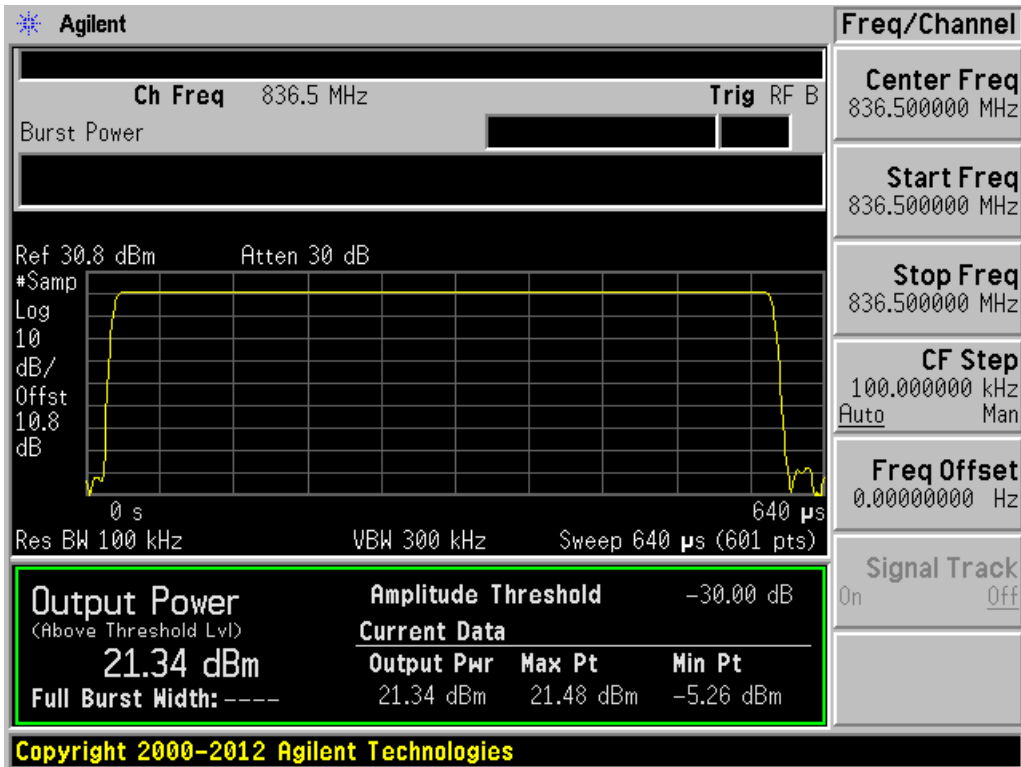


Downlink 879.5 MHz AWGN Channel Power Limit

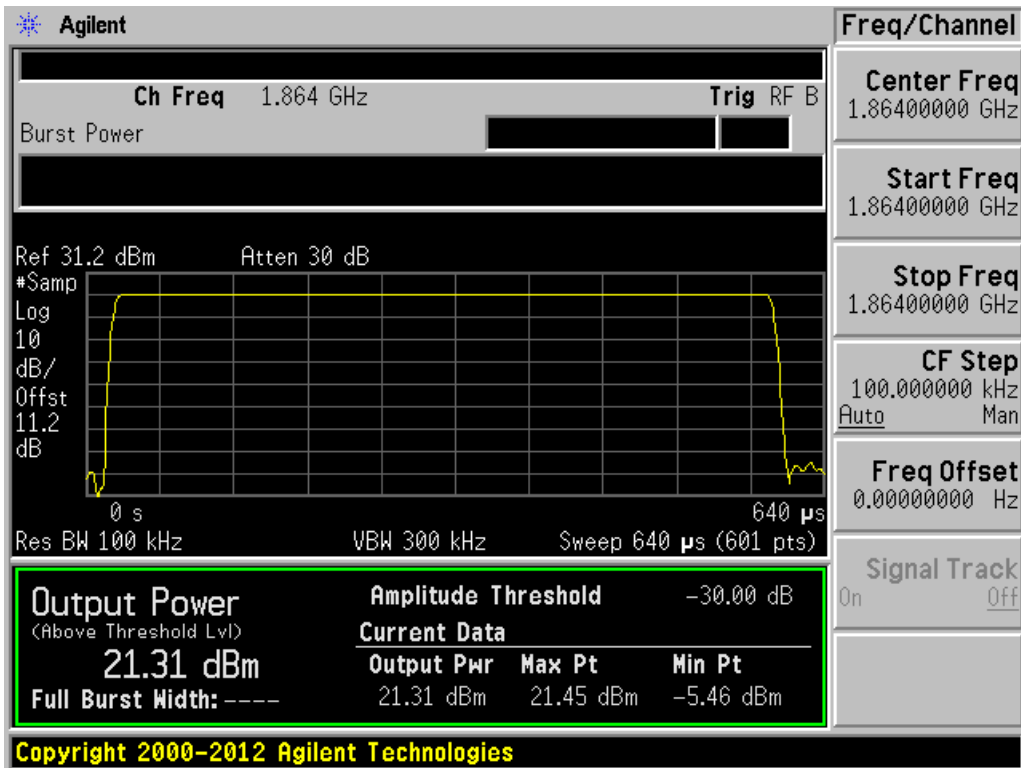


Downlink 1961.6 MHz AWGN Channel Power Limit

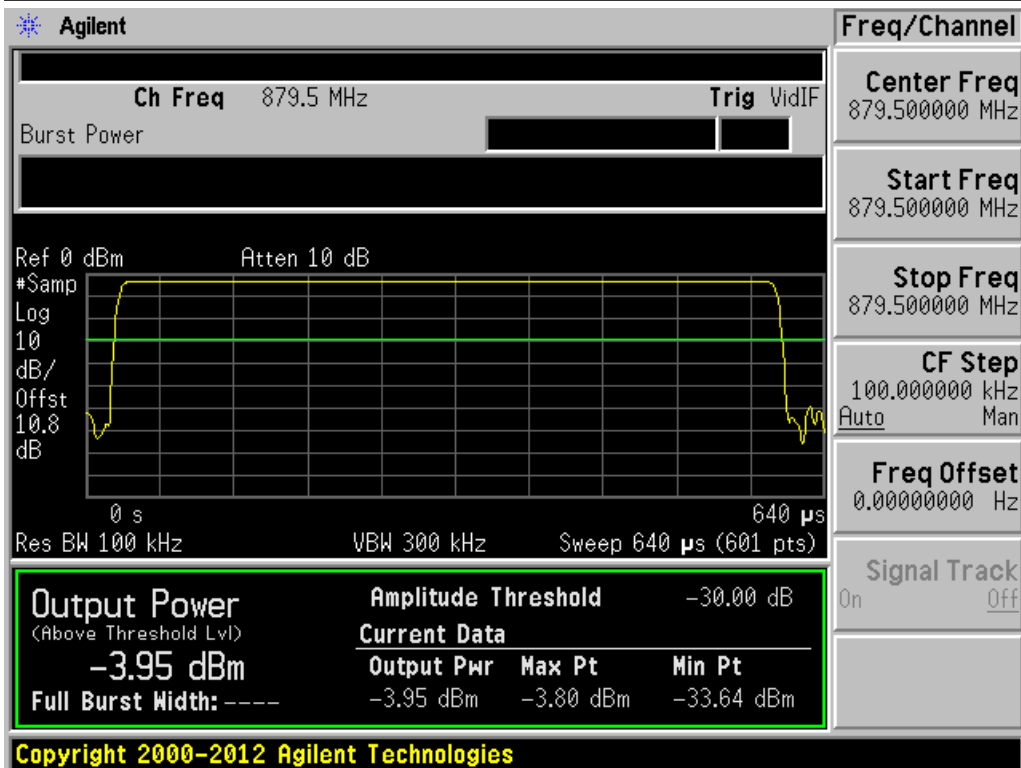
3.4.4 Pulsed CW power test results



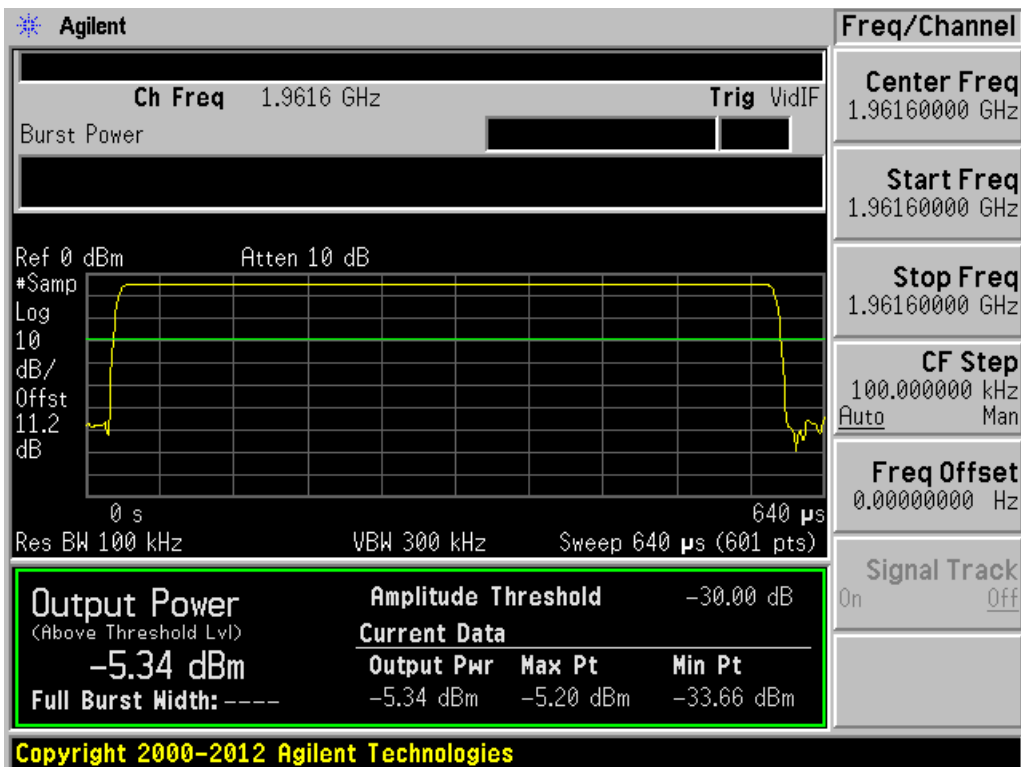
Uplink 836.5MHz Pulsed CW Power Limit



Uplink 1864 MHz Pulsed CW Power Limit



Downlink 879.5 MHz Pulsed CW Power Limit



Downlink 1961.6 MHz Pulsed CW Power Limit

3.5 Part 20.21 § (e)(8)(i)(E) Out of Band Emission Limits.

Booster out of band emissions (OOBE) shall be at least 6 dB below the FCC's mobile emission limits for the supported bands of operation.

Compliance to OOBE limits will utilize high peak-to-average CMRS signal types.

§ 22.917 Emission limitations for cellular equipment.

The rules in this section govern the spectral characteristics of emissions in the Cellular Radiotelephone Service.

(a) *Out of band emissions.* The power of any emission outside of the authorized operating frequency ranges must be attenuated below the transmitting power (P) by a factor of at least $43 + 10 \log(P)$ dB.

§ 24.238 Emission limitations for Broadband PCS equipment.

The rules in this section govern the spectral characteristics of emissions in the Broadband Personal Communications Service.

(a) *Out of band emissions.* The power of any emission outside of the authorized operating frequency ranges must be attenuated below the transmitting power (P) by a factor of at least $43 + 10 \log(P)$ dB.

3.5.1 Out of band emissions test procedure

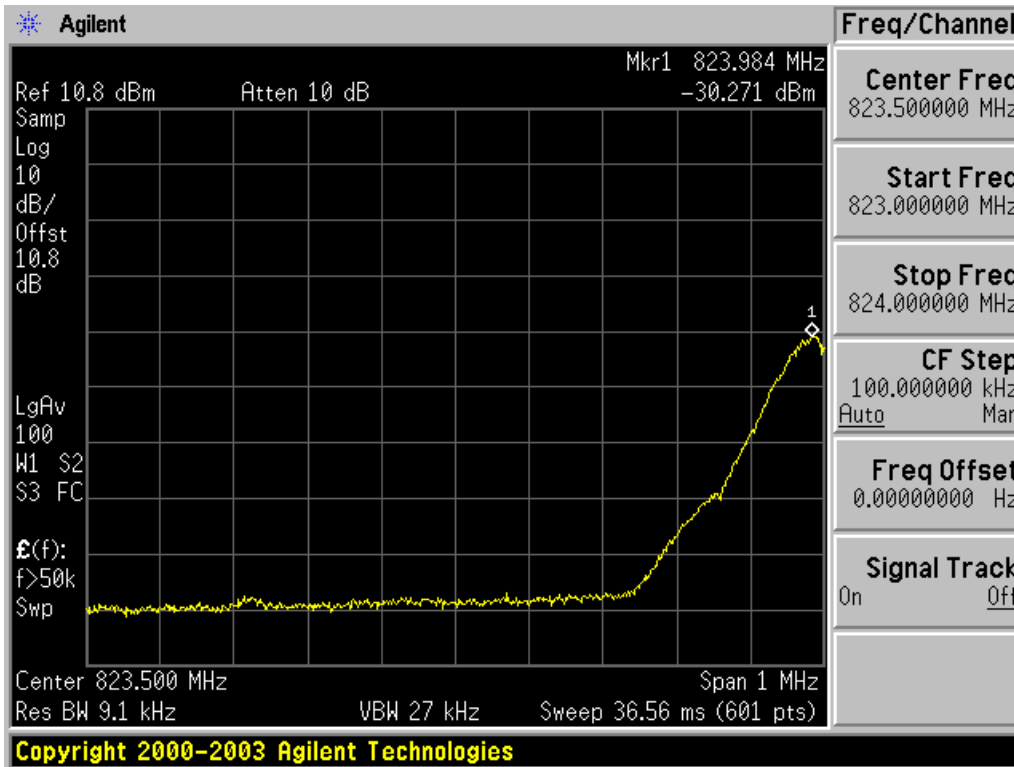
(Reference: KDB #935210 D03, § 7.5)



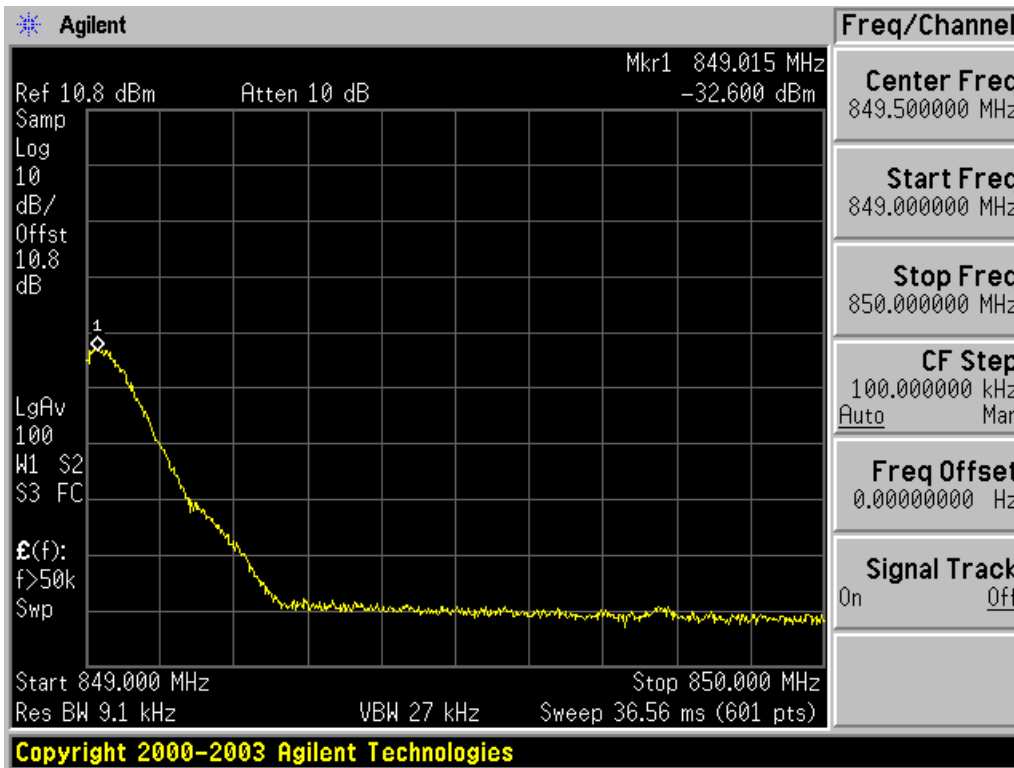
Figure 7

- A. Connect the EUT to the test equipment as shown in figure 7. Begin with the uplink output connected to the spectrum analyzer.
- B. Configure the signal generator for the appropriate operation for all uplink and downlink bands:
 - GSM: 0.2 MHz from upper and lower band edge
 - LTE: 2.5 MHz from upper and lower band edge
 - CDMA: 1.25 MHz from upper and lower band edge, except for cellular as follows (only the upper and lower frequencies need to be tested):
 - 824.88 MHz
 - 848.10 MHz
 - 869.88 MHz
 - 893.10 MHz
- C. Set the signal generator power to a level just below (within 0.5 dB of) the AGC limit without triggering the AGC. Configure signal generator with appropriate modulations.
- D. Set RBW = measurement bandwidth specified in the applicable rule section for the supported frequency band.
- E. Set VBW = 3 X RBW.
- F. Select the RMS (power averaging) detector.
- G. Sweep time = auto-couple.
- H. Set the analyzer start frequency to the upper band/block edge frequency and the stop frequency to the upper band/block edge frequency plus 100 kHz or 1 MHz, per applicable rule part.
- I. Trace average at least 100 traces in power averaging (i.e., RMS) mode.
- J. Use peak marker function to find the maximum power level.
- K. Capture the Spectrum Analyzer trace of the power level for inclusion in the test report.
- L. Ensure that the EUT maintains compliance with the OOB limits.
- M. Reset the analyzer start frequency to the lower band/block edge frequency minus 100 kHz or 1 MHz, as per applicable rule part, and the stop frequency to the lower band/block edge frequency and repeat steps J to L.
- N. Repeat steps A through M for each uplink and downlink operational band.

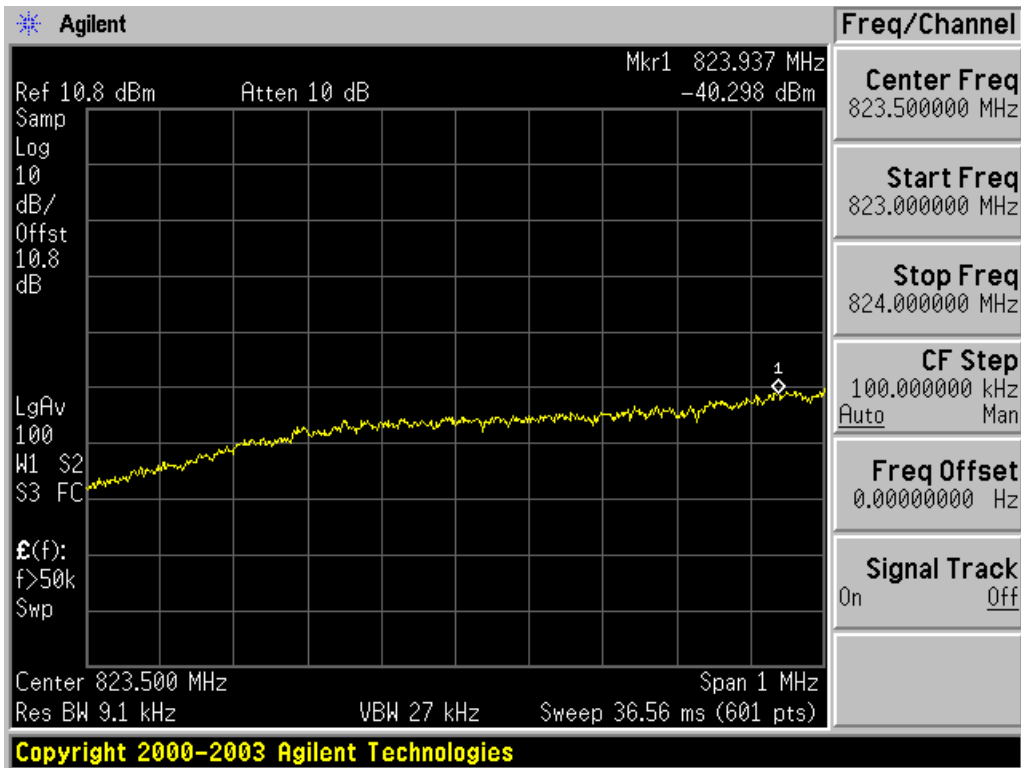
3.5.2 Out of band emissions test results



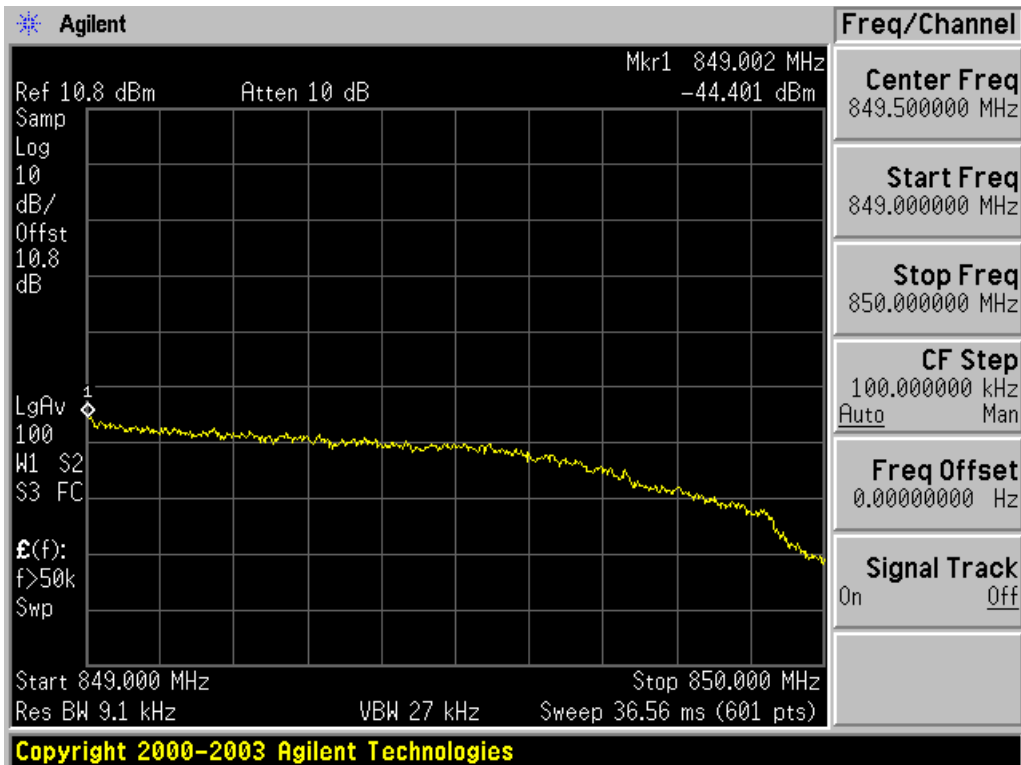
Uplink GSM signal 824.2 MHz



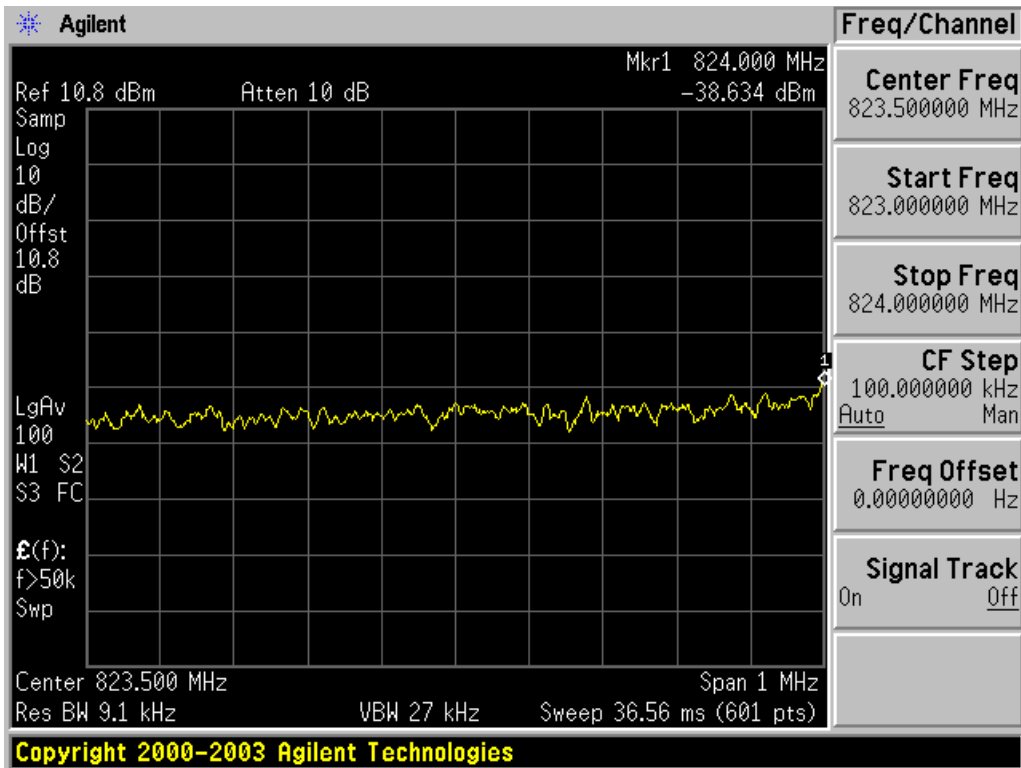
Uplink GSM signal 848.8 MHz



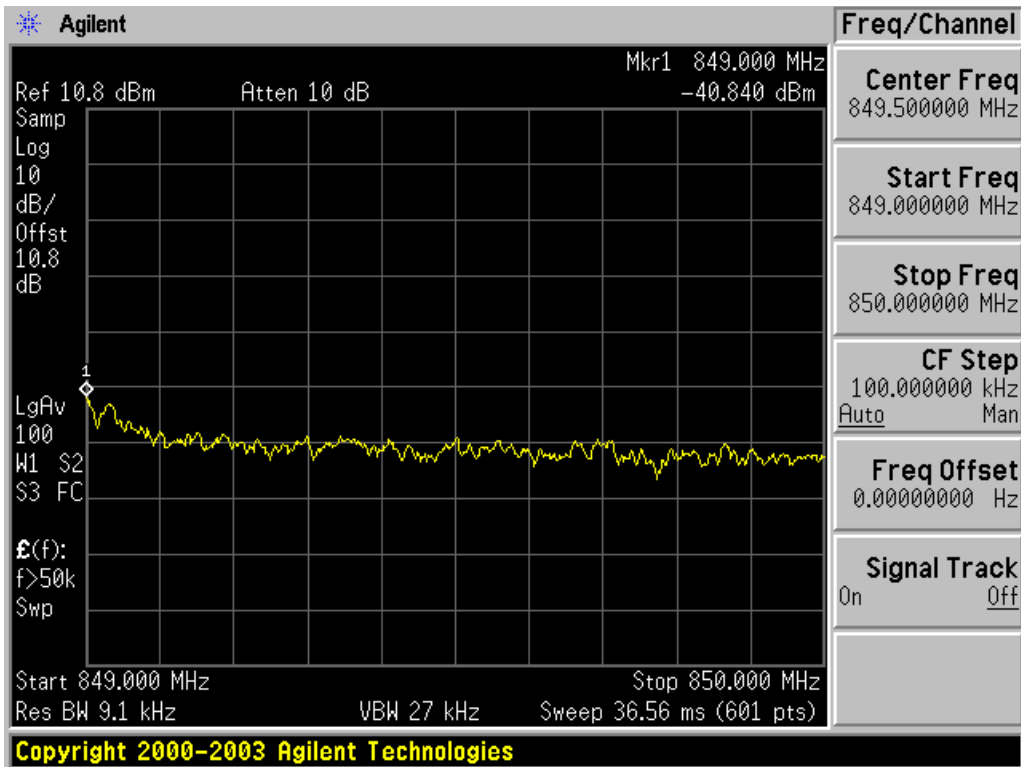
Uplink CDMA signal 824.88 MHz



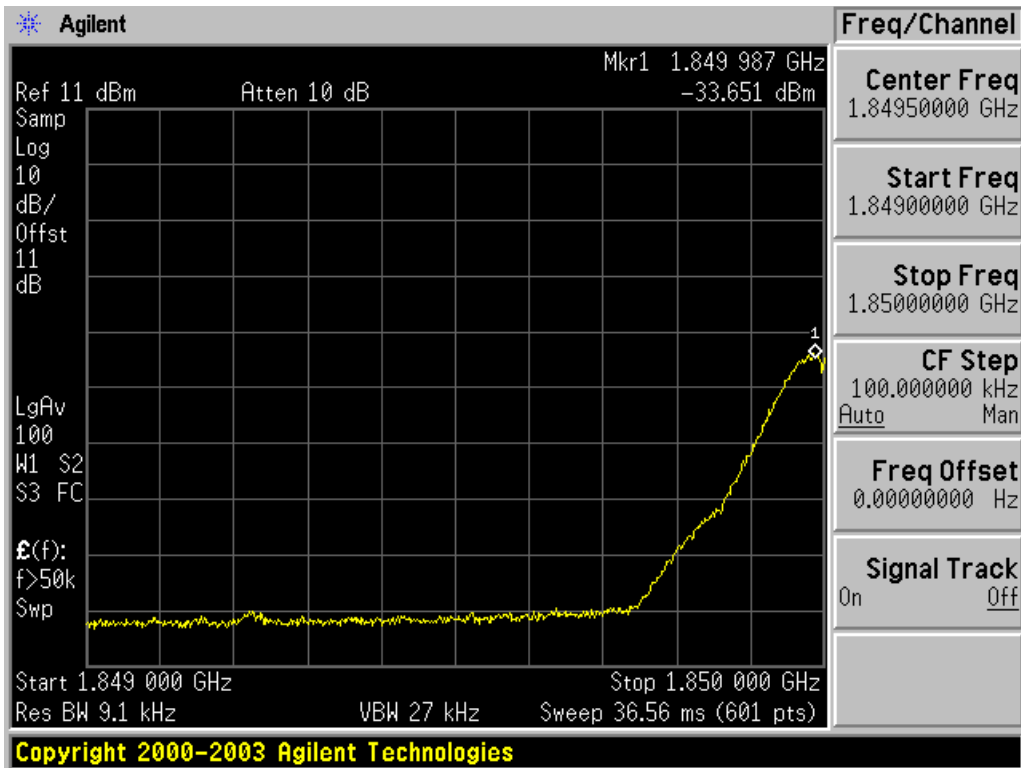
Uplink CDMA signal 848.10 MHz



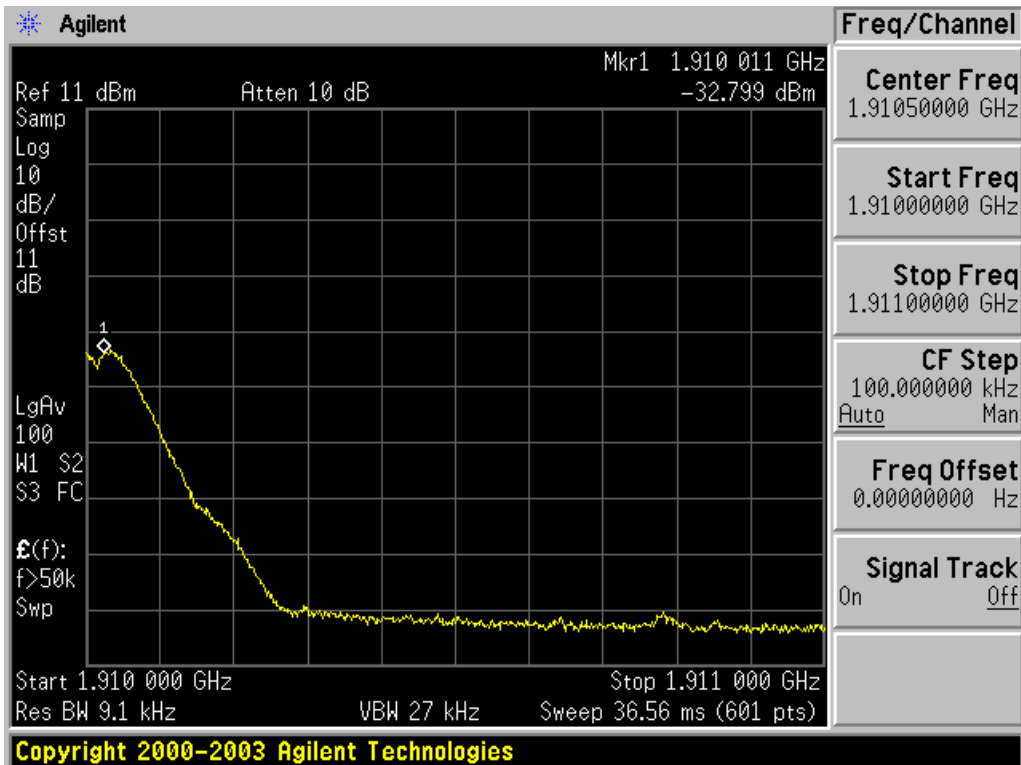
Uplink LTE Signal 826.5 MHz



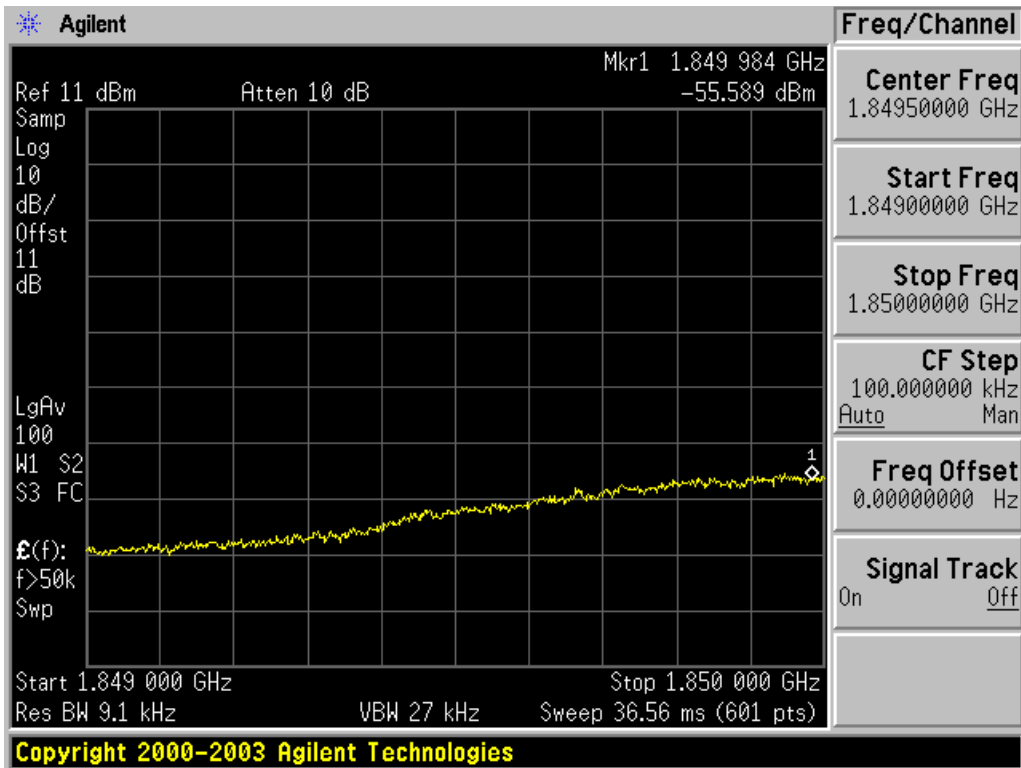
Uplink LTE Signal 846.5 MHz



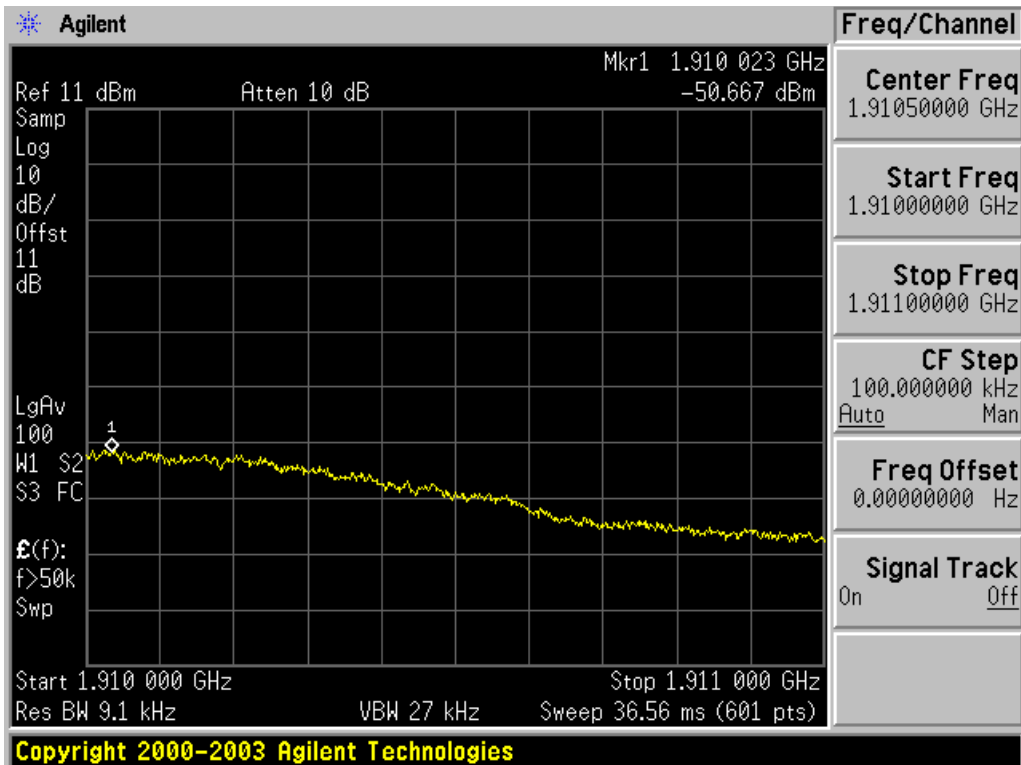
Uplink GSM signal 1850.2 MHz



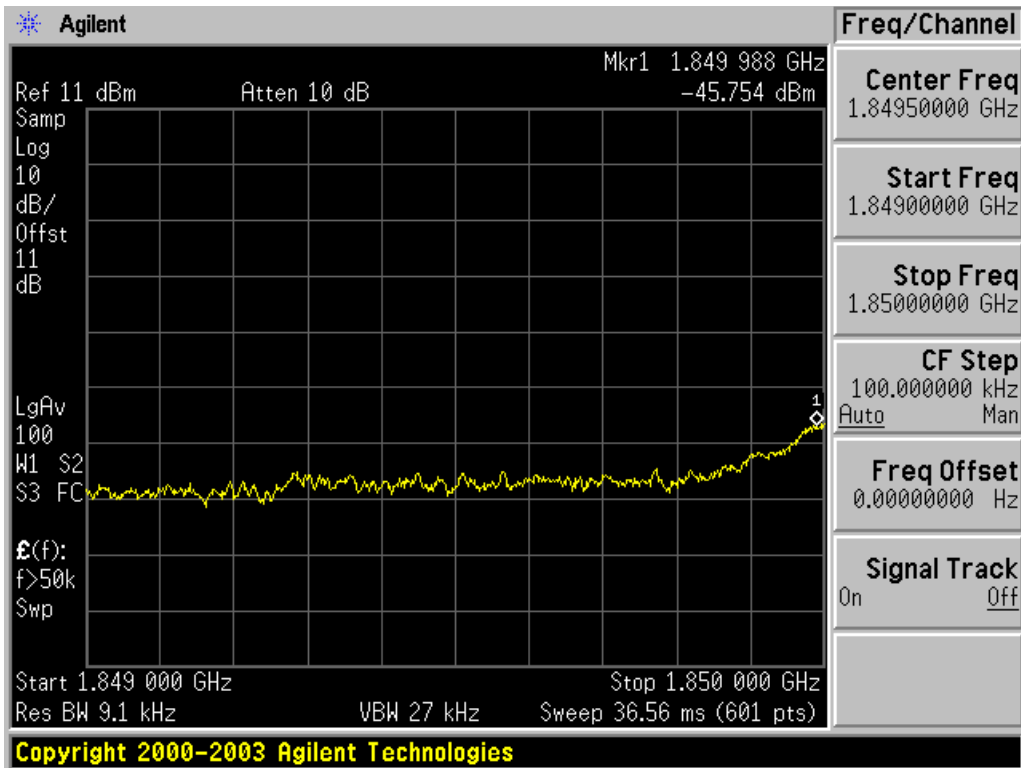
Uplink GSM signal 1909.8 MHz



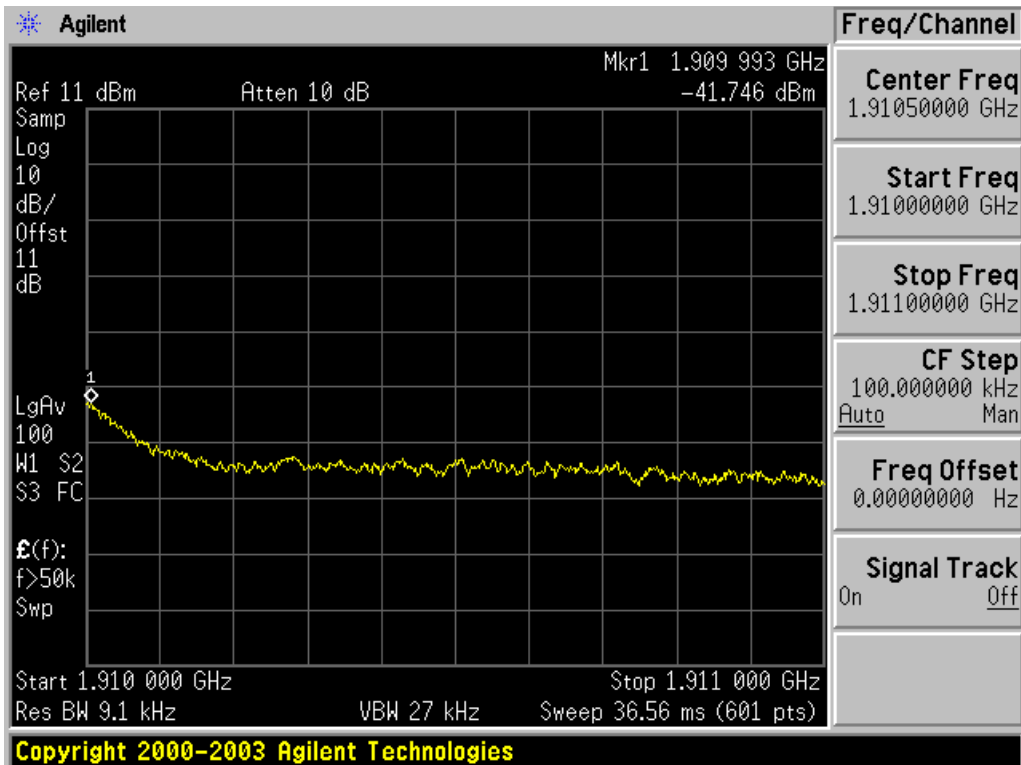
Uplink CDMA signal 1851.25 MHz



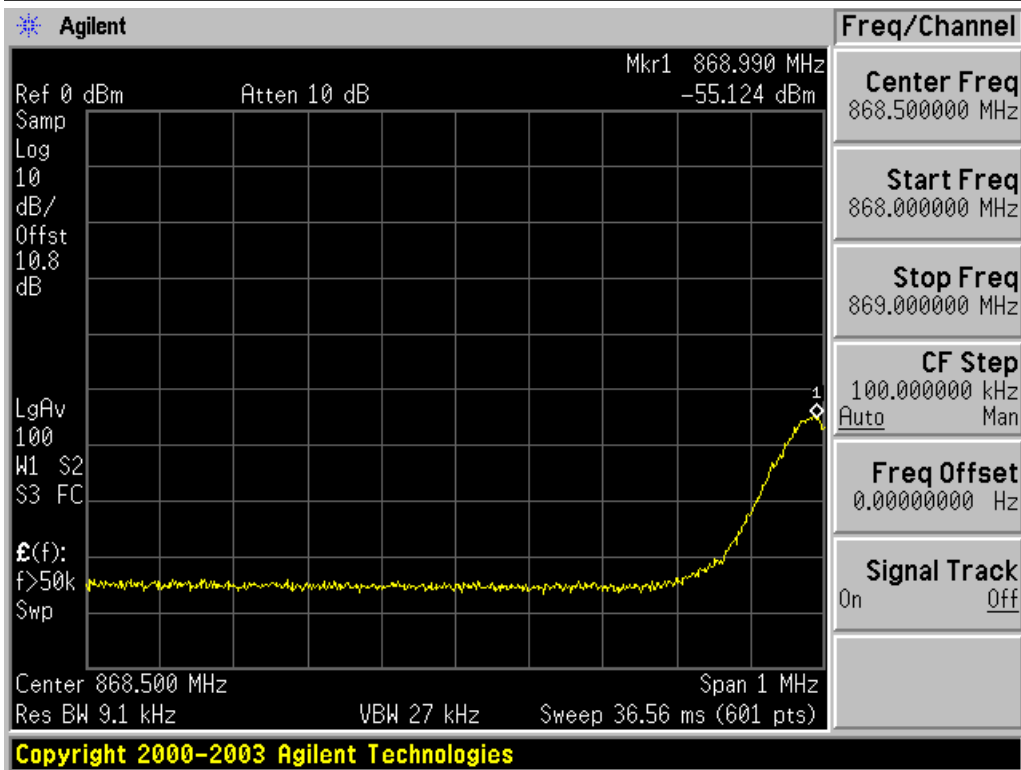
Uplink CDMA signal 1908.75 MHz



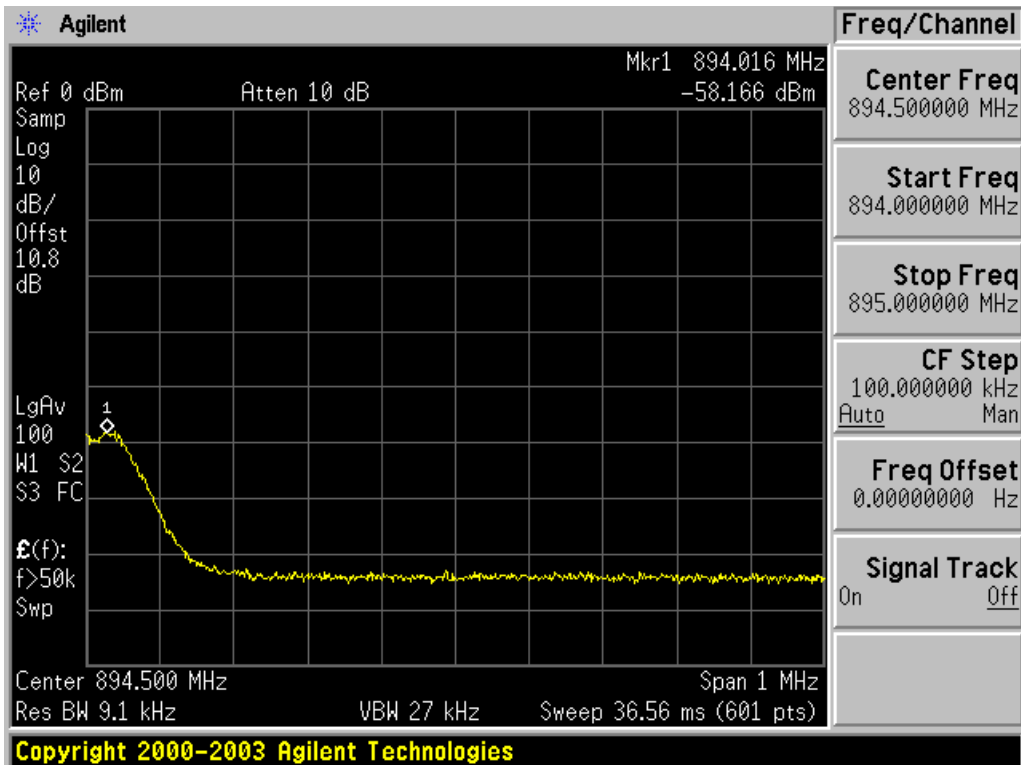
Uplink LTE Signal 1852.5 MHz



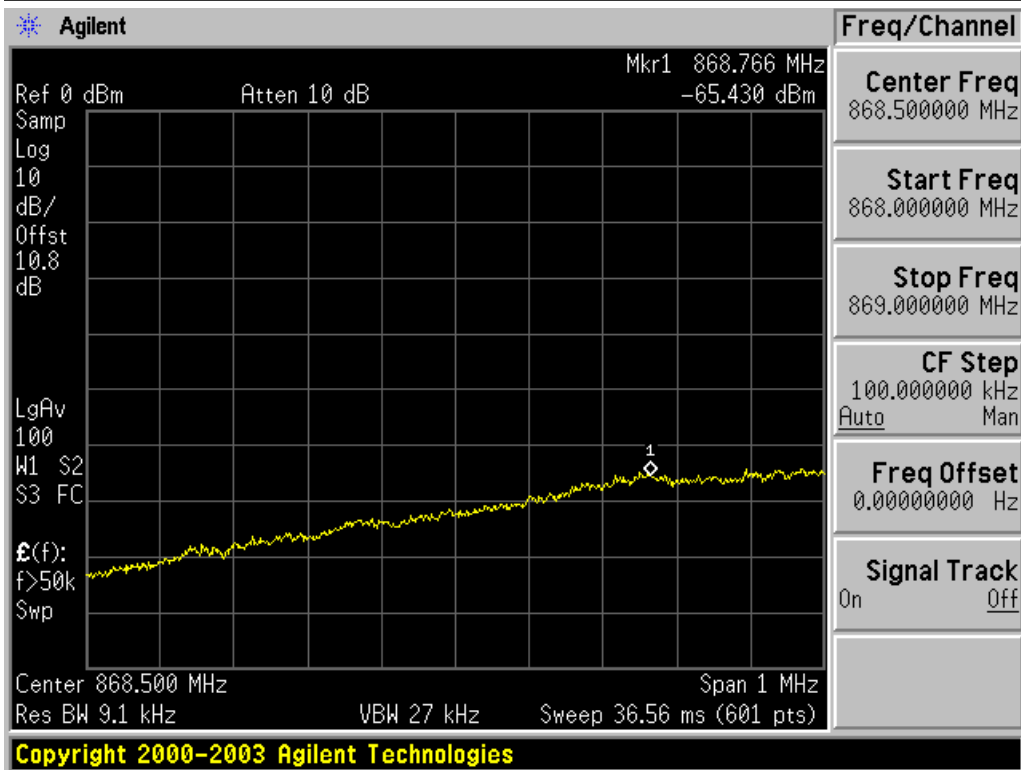
Uplink LTE Signal 1907.5 MHz



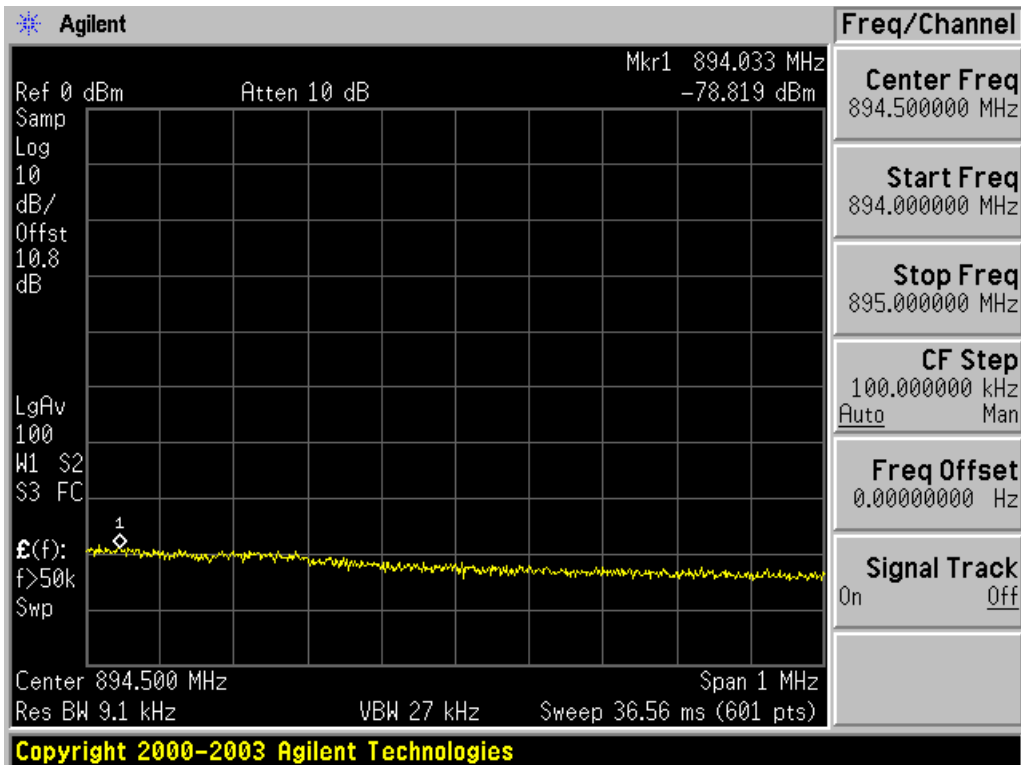
Downlink GSM signal 869.2 MHz



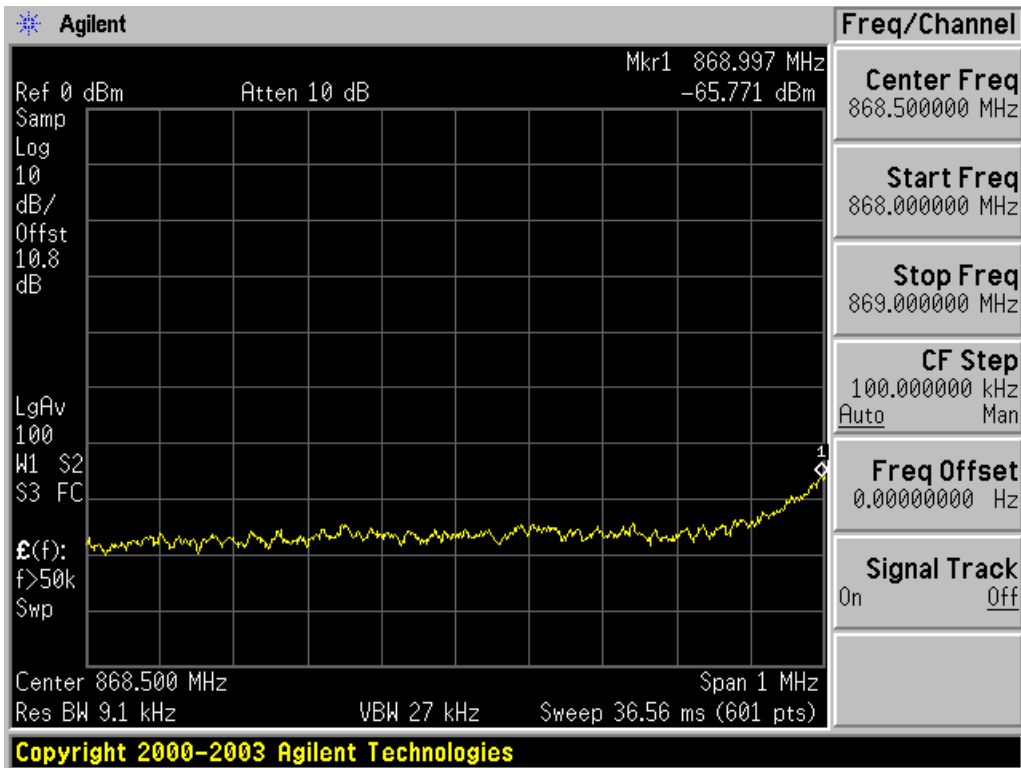
Downlink GSM signal 893.8 MHz



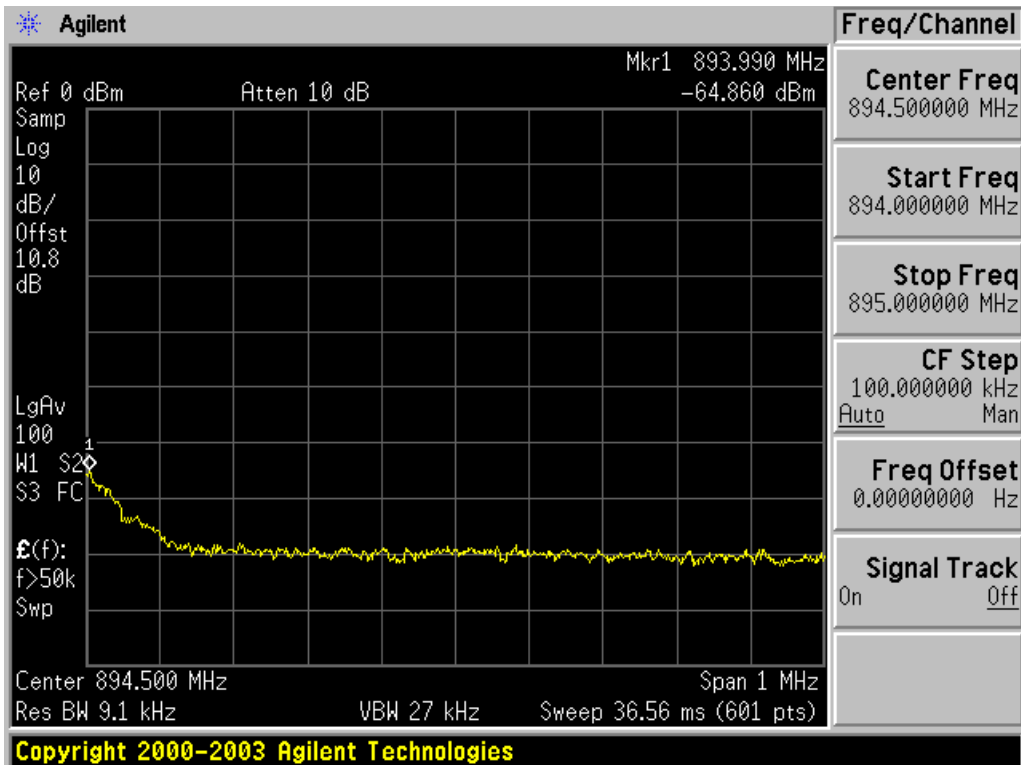
Downlink CDMA signal 869.88 MHz



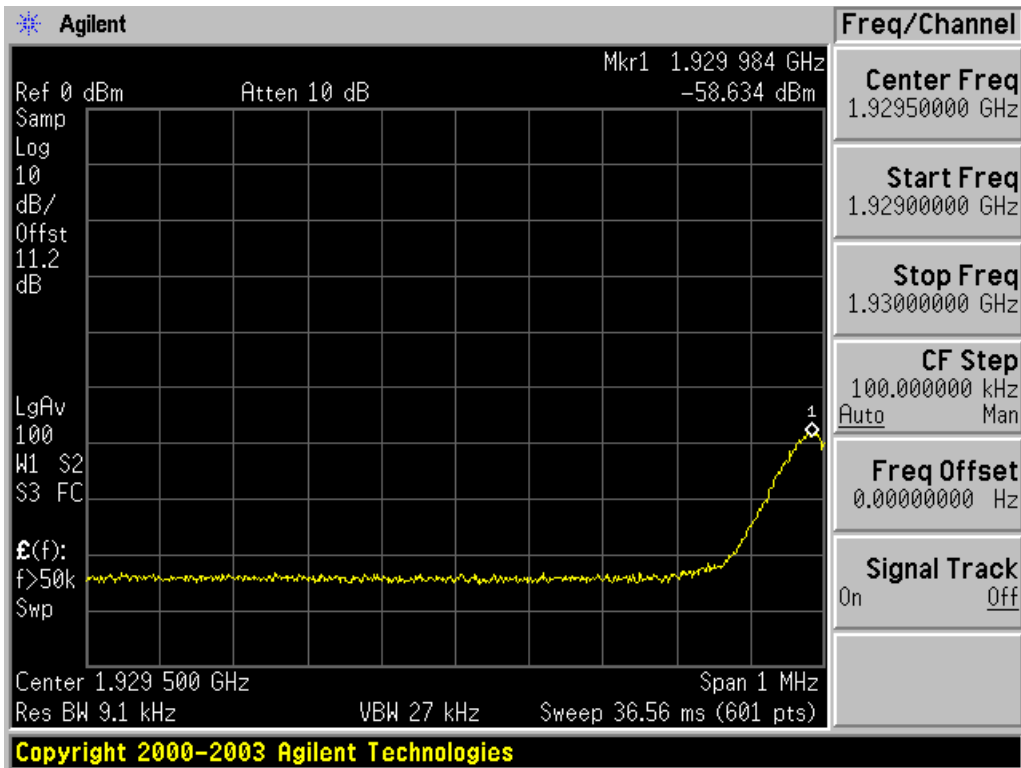
Downlink CDMA signal 893.10 MHz



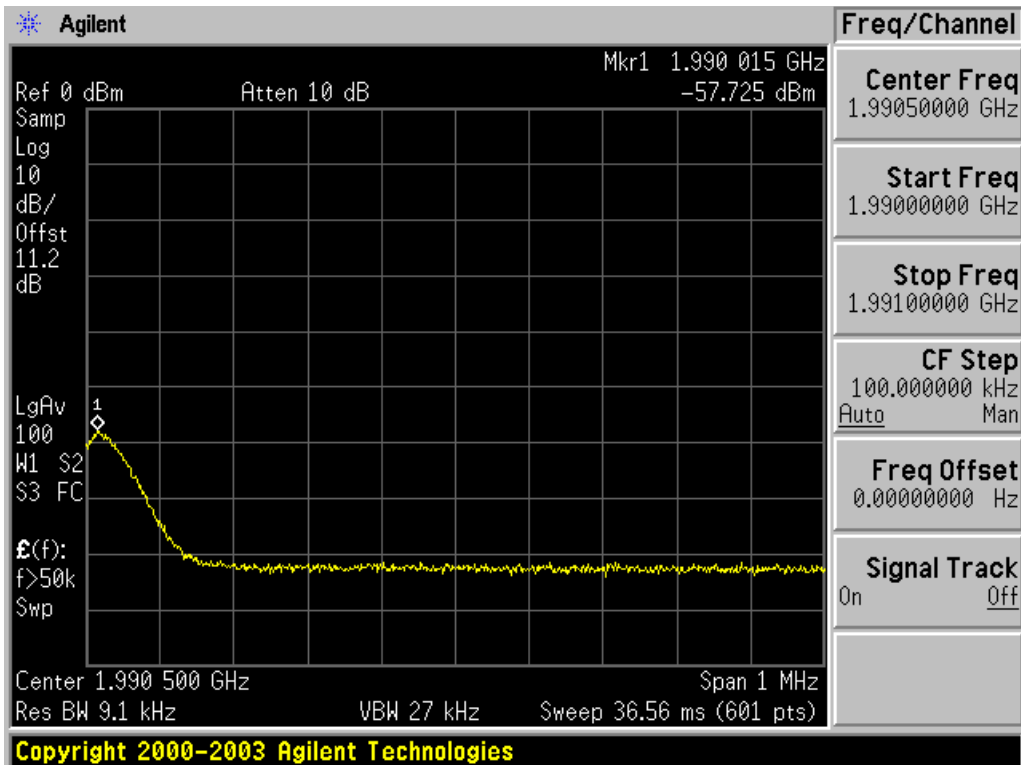
Downlink LTE Signal 871.5 MHz



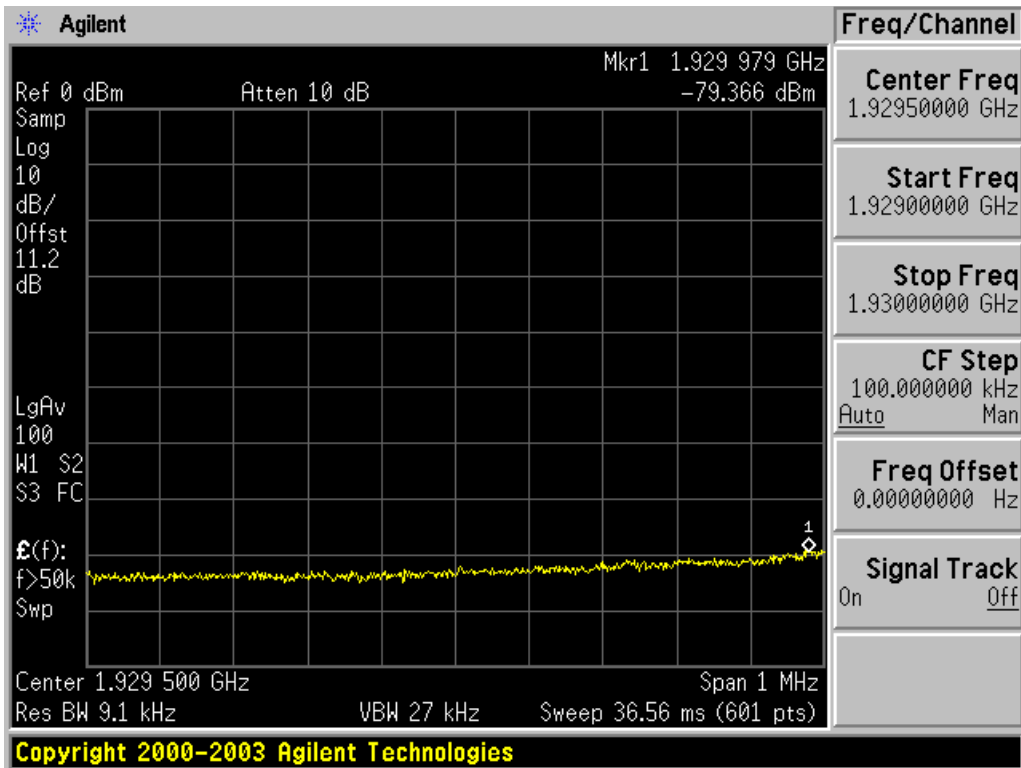
Downlink LTE Signal 891.5 MHz



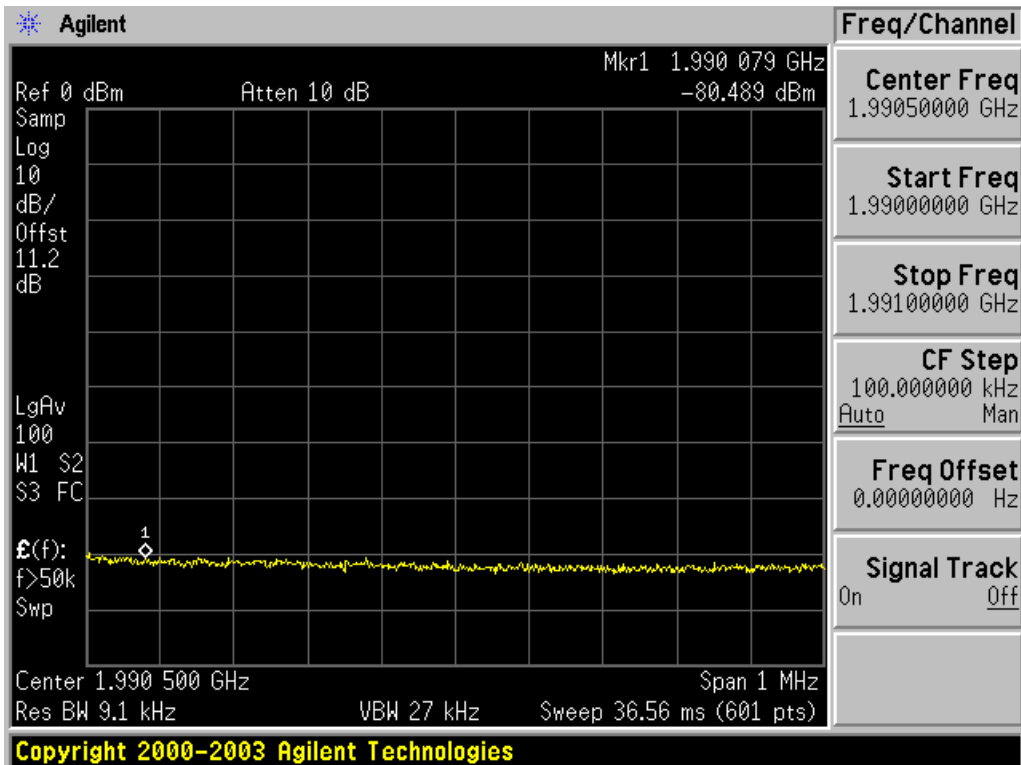
Downlink GSM signal 1930.2 MHz



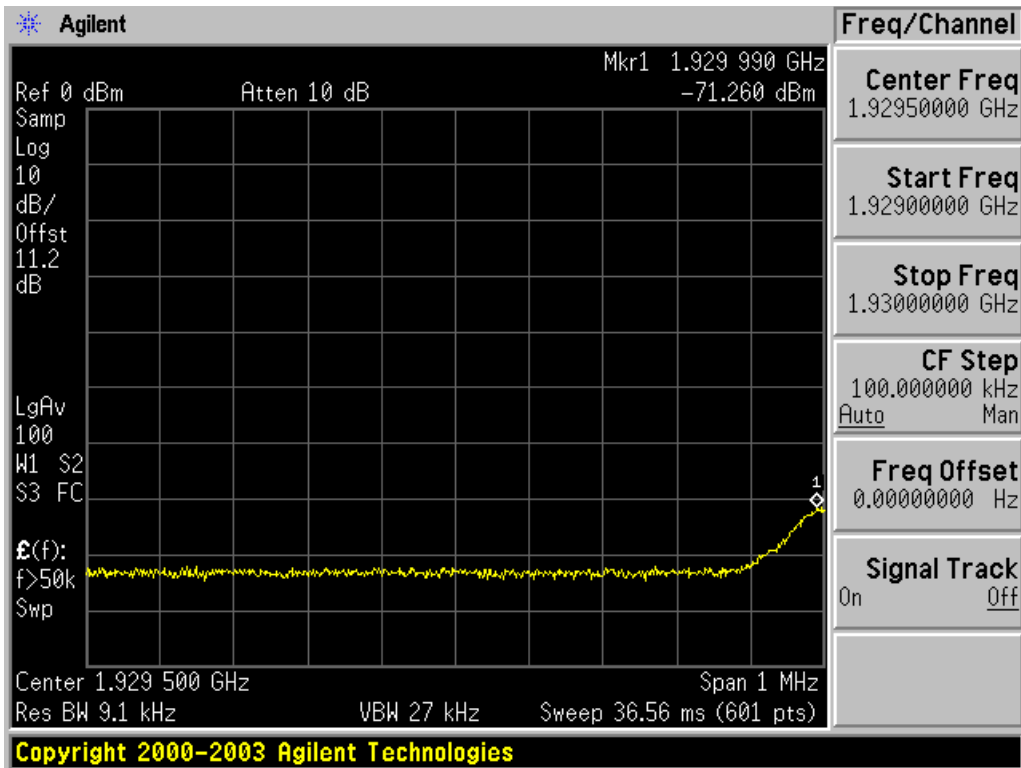
Downlink GSM signal 1989.8 MHz



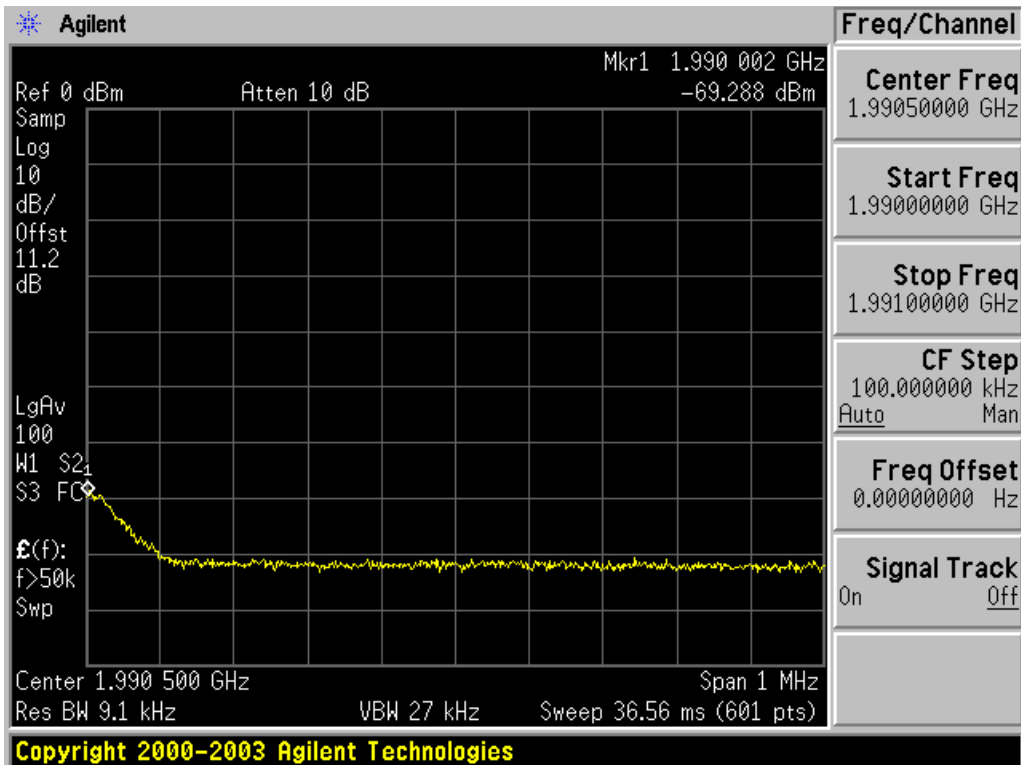
Downlink CDMA signal 1931.25 MHz



Downlink CDMA signal 1988.75 MHz



Downlink LTE Signal 1932.5 MHz



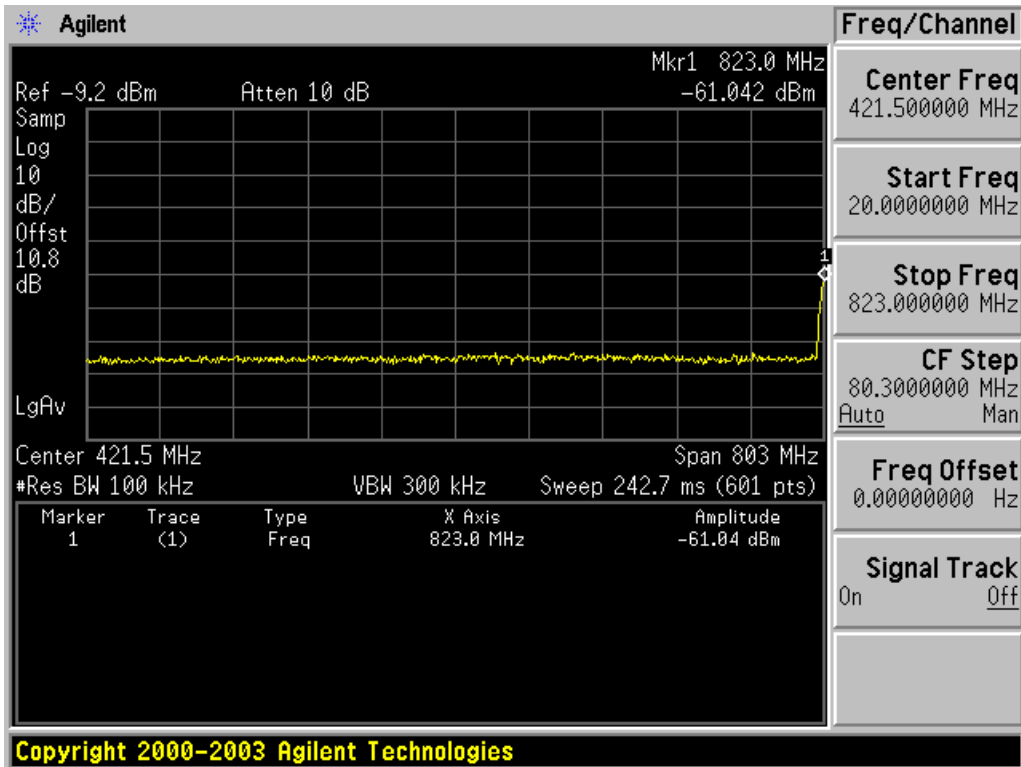
Downlink LTE Signal 1987.5 MHz

3.5.3 Conducted spurious emissions test procedure

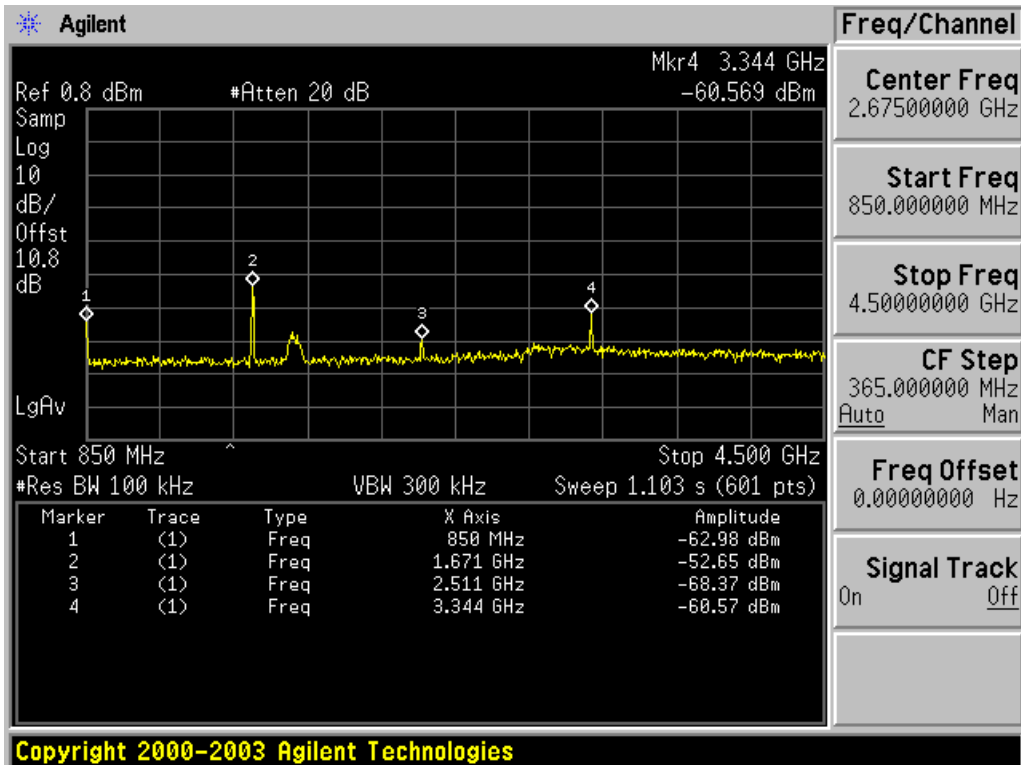
(Reference: KDB #935210 D03, § 7.6)

- A. Connect the EUT to the test equipment as shown in Figure 7. Begin with the uplink output connected to the spectrum analyzer.
- B. Configure the signal generator for AWGN with an emissions bandwidth of 4.1 MHz operation with a center frequency corresponding to the center of the operational band under test and with a bandwidth representative of the bandwidth of the uplink or downlink signal.
- C. Set the signal generator power to a level just below (within 0.5 dB of) the AGC limit without triggering the AGC.
- D. Turn on the signal generator RF output and measure the spurious emission power levels with an appropriate measurement instrument as follows:
- E. Set RBW 100 KHz
- F. Set VBW = 3 X RBW.
- G. Select the power averaging (RMS) detector.
- H. Sweep time = auto-couple.
- I. Set the analyzer start frequency to the lowest radio frequency signal generated in the equipment, without going below 9 kHz, and the stop frequency to the lower band/block edge frequency minus 100 kHz or 1 MHz, as specified in the applicable rule part. Note that the number of measurement points in each sweep must be $\geq (2 \times \text{span}/\text{RBW})$ which may require that the measurement range defined by the start and stop frequencies above be subdivided, depending on the available number of measurement points provided by the spectrum analyzer trace average at least 10 traces in power averaging (i.e., RMS) mode.
- J. Use the peak marker function to identify the highest amplitude level over each measured frequency range. Record the frequency and amplitude and capture a plot for inclusion in the test report.
- K. Reset the analyzer start frequency to the upper band/block edge frequency plus 100 kHz or 1 MHz, as specified in the applicable rule part, and the analyzer stop frequency to 10 times the highest frequency of the fundamental emission. Note that the number of measurement points in each sweep must be $\geq (2 \times \text{span}/\text{RBW})$ which may require that the measurement range defined by the start and stop frequencies above be subdivided, depending on the available number of measurement points provided by the spectrum analyzer.
- L. Use the peak marker function to identify the highest amplitude level over each of the measured frequency ranges. Record the frequency and amplitude and capture a plot for inclusion in the test report.
- M. Repeat steps A through L for each supported frequency band of operation.

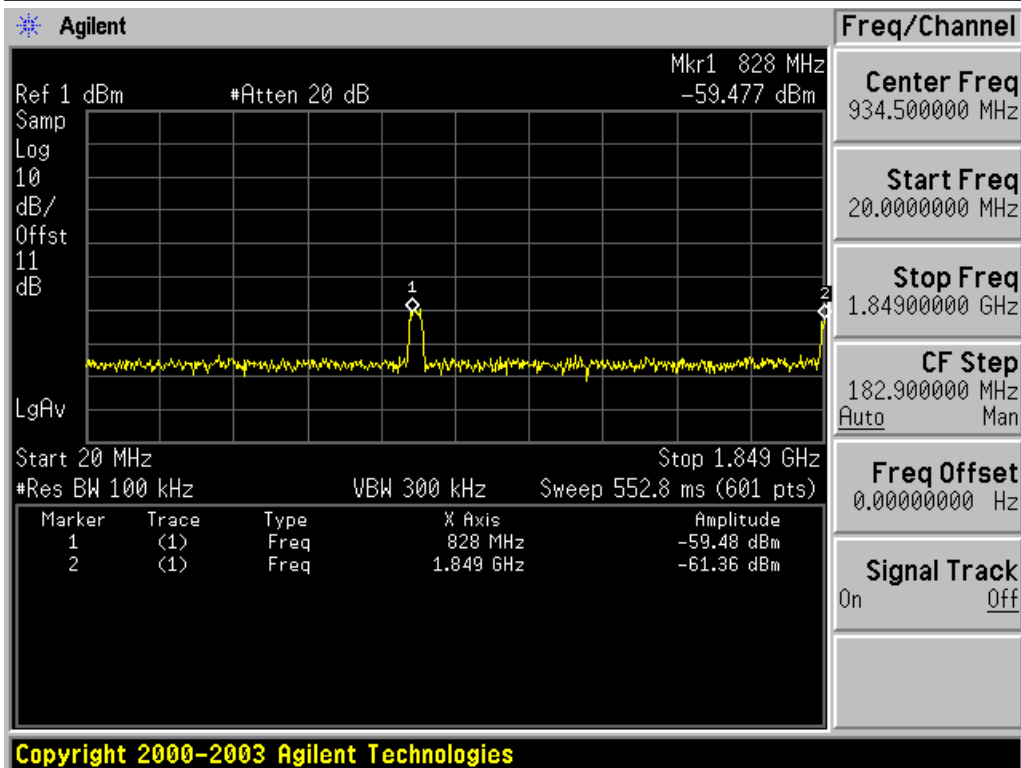
3.5.4 Conducted spurious emissions test results



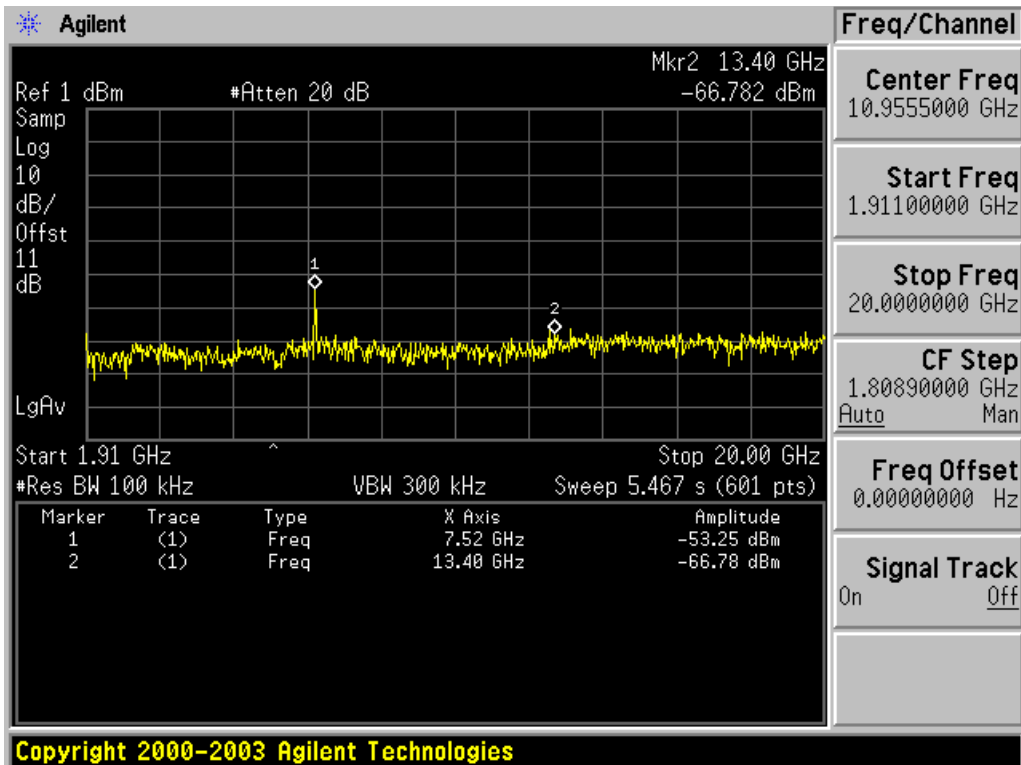
Uplink 800 MHz Conducted Spurious Emissions 20 MHz to 823 MHz



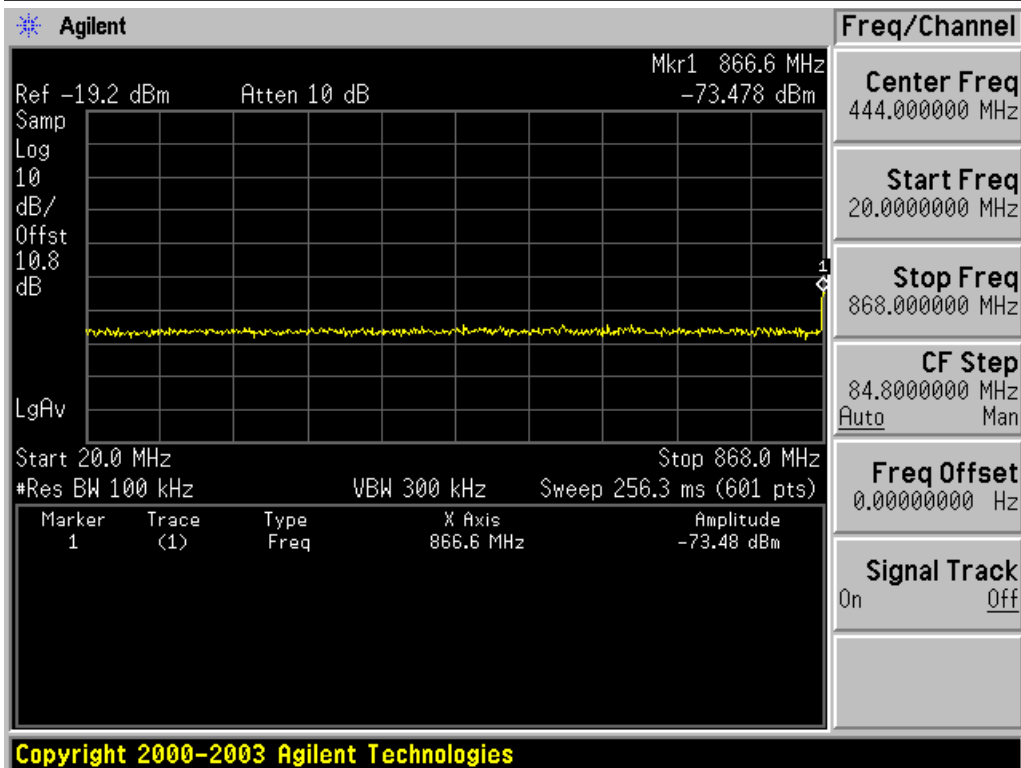
Uplink 800 MHz Conducted Spurious Emissions 850 MHz to 9 GHz



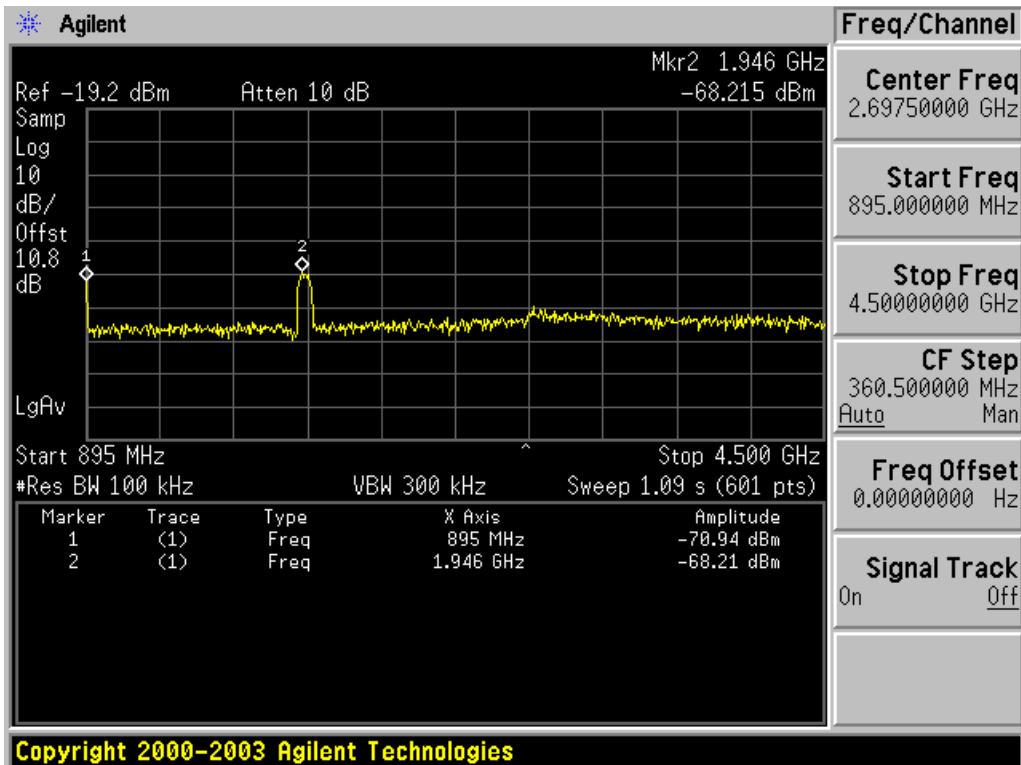
Uplink 1900 MHz Conducted Spurious Emissions 20 MHz to 1849 MHz



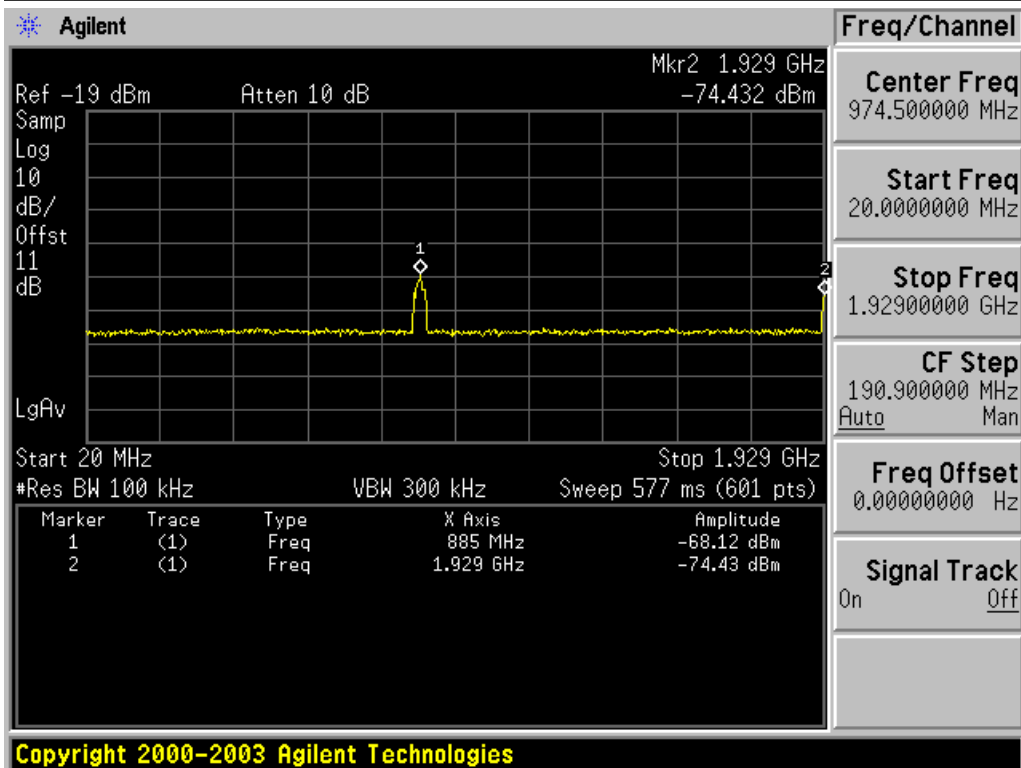
Uplink 1900 MHz Conducted Spurious Emissions 1911 MHz to 20 GHz



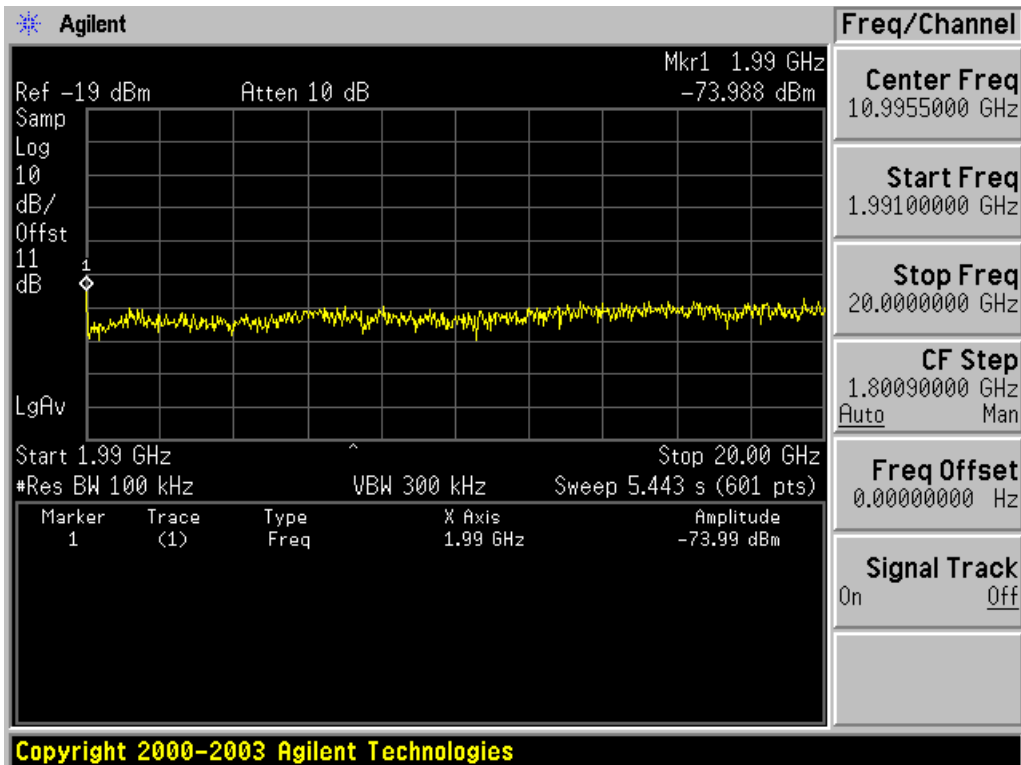
Downlink 800 MHz Conducted Spurious Emissions 20 MHz to 868 MHz



Downlink 800 MHz Conducted Spurious Emissions 895 MHz to 9 GHz



Downlink 1900 MHz Conducted Spurious Emissions 20 MHz to 1929 MHz



Downlink 1900 MHz Conducted Spurious Emissions 1991 MHz to 20 GHz

3.6 Part 20.21 § (e)(8)(i)(F) Intermodulation Limits.

The transmitted intermodulation products of a consumer booster at its uplink and downlink ports shall not exceed the power level of -19 dBm for the supported bands of operation. Compliance with intermodulation limits will use boosters operating at maximum gain and maximum rated output power, with two continuous wave (CW) input signals spaced 600 kHz apart and centered in the pass band of the booster, and with a 3 kHz measurement bandwidth.

3.6.1 Intermodulation product test procedure

(Reference: KDB #935210 D03, § 7.4)

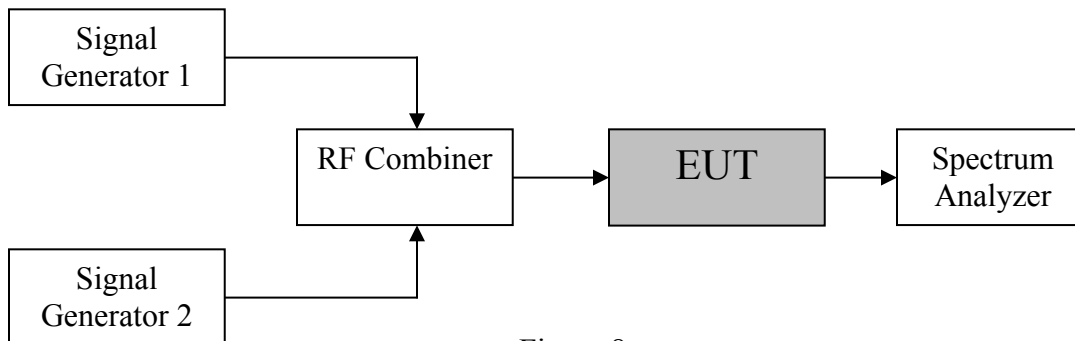
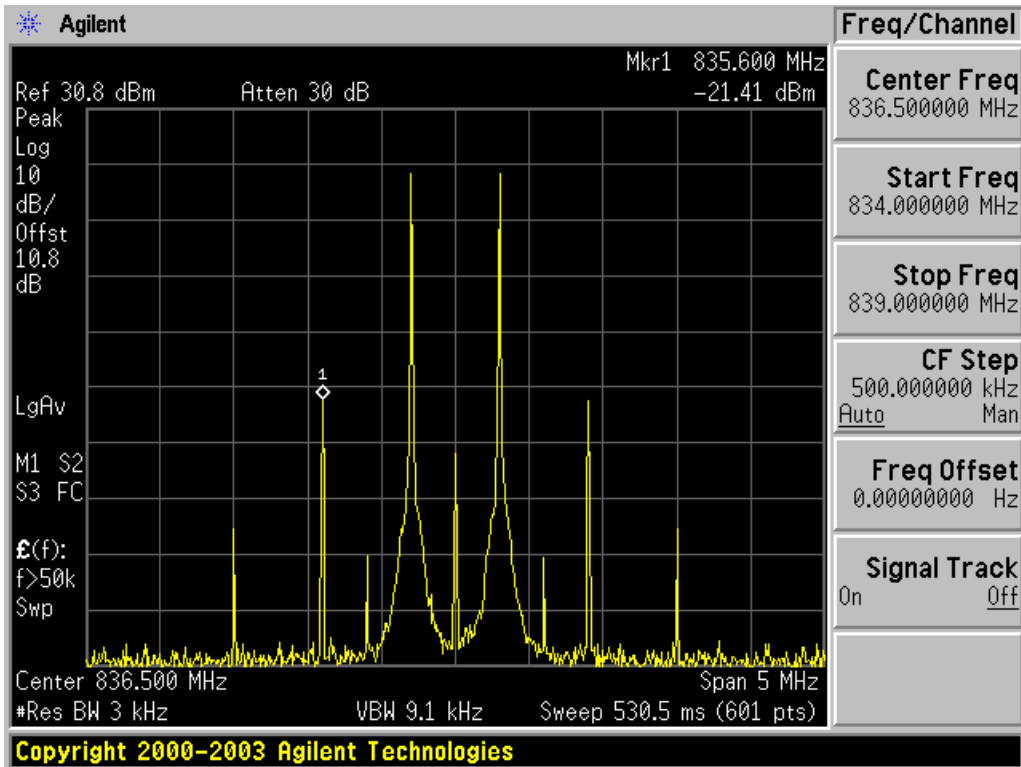


Figure 8

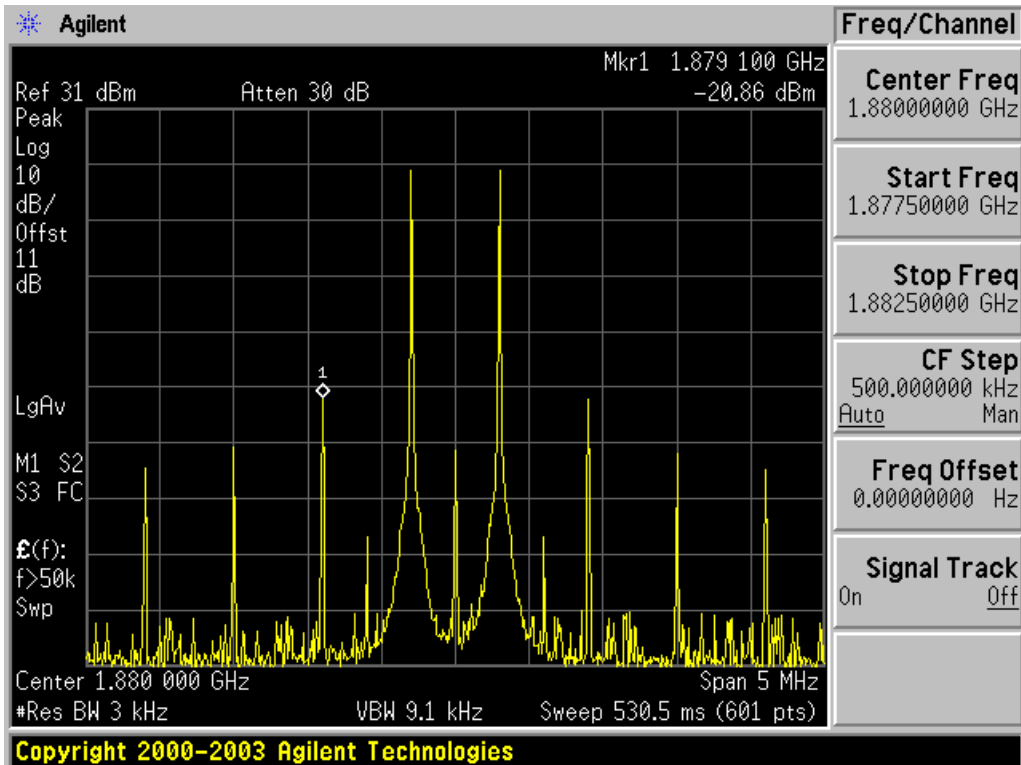
- A. Connect the signal booster to the test equipment as shown in Figure 8. Begin with the uplink output connected to the spectrum analyzer.
- B. Set the spectrum analyzer RBW = 3 kHz.
- C. Set the VBW $\geq 3 \times$ the RBW.
- D. Select the RMS detector.
- E. Set the spectrum analyzer center frequency to the center of the supported operational band under test.
- F. Set the span to 5 MHz.
- G. Configure the two signal generators for CW operation with generator 1 tuned 300 kHz below the operational band center frequency and generator 2 tuned 300 kHz above the operational band center frequency.
- H. Set the signal generator amplitudes so that the power from each into the RF combiner is equivalent and turn on the RF output.
- I. Increase the signal generators' amplitudes equally until just before the EUT begins AGC and ensure that all intermodulation products (if any exist), are below the specified limit of -19 dBm.
- J. Utilize the MAX HOLD function of the spectrum analyzer and wait for the trace to stabilize. Place a marker at the highest amplitude intermodulation product.
- K. Record the maximum intermodulation product amplitude level that is observed.
- L. Capture the spectrum analyzer trace for inclusion in the test report.
- M. Repeat steps A to L for all uplink and downlink operational bands.

Note: If using a single signal generator with dual outputs, ensure that intermodulation products are not the result of the generator.

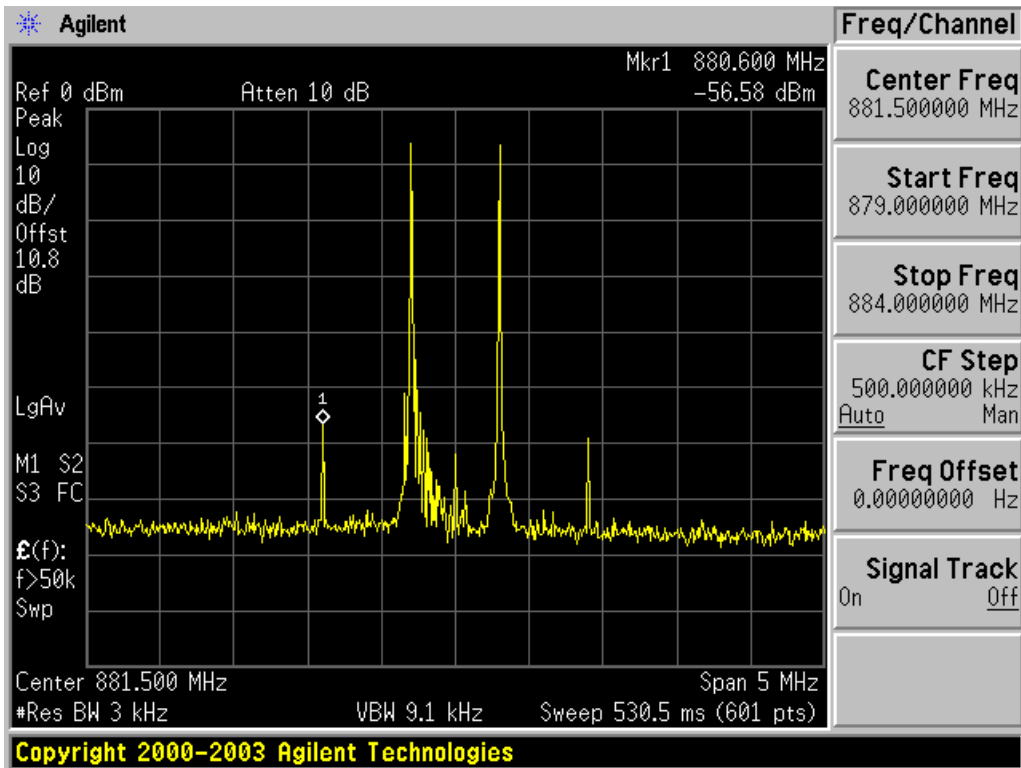
3.6.2 Intermodulation product test results



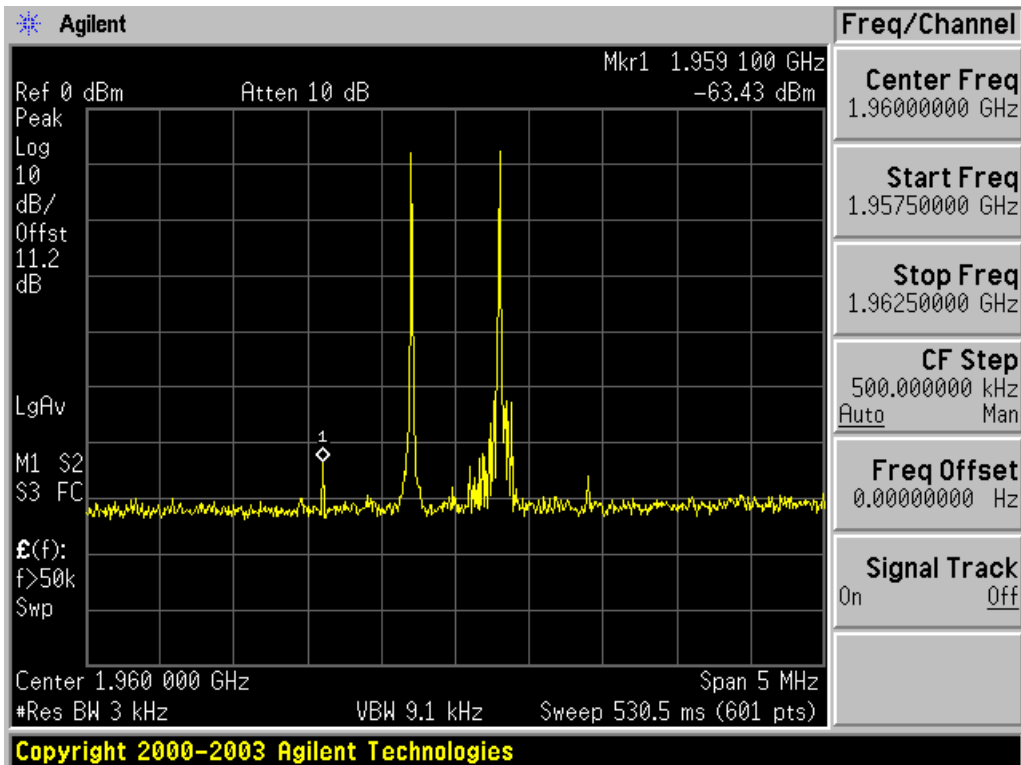
Uplink 836.5 MHz.



Uplink 1880 MHz.



Downlink 881.5 MHz.



Downlink 1960 MHz.

3.7 Part 20.21 § (e)(8)(i)(G) Booster Antenna Kitting.

All consumer boosters must be sold with user manuals specifying all antennas and cables that meet the requirements of this section. All consumer boosters must be sold together with antennas, cables, and/or coupling devices that meet the requirements of this section. The grantee is required to submit a technical document with the application for FCC equipment authorization that shows compliance of all antennas, cables and / or coupling devices with the requirements of this section, including any antenna or equipment upgrade options that may be available at initial purchase or as a subsequent upgrade.

Table 9: Cables

Cable Part #	Description	Cable	Minimum Cable loss (dB)
ACX100	Server antenna extension cable	4 ft. SEMRC105	-0.44
ACX900	Server antenna extension cable	9 ft. SEMRC105	-1.00

Table 10: Server Antennas

Inside Server Antenna Part #	Description	Cable	Minimum Cable loss (dB)	Maximum Antenna Gain (dBi)	Net gain (dBi)
SEMRP1X	Inside server antenna	4 ft. SEMRC105	-1.0	0.00	-1
SEMRP1XL	Inside server antenna	7 ft. SEMRC105	-1.5	0.00	-1.5
SEMR1	Inside server antenna	Direct (no cable)	-1.5	0.00	2.1

Table 11: Outside Antennas

Antenna Part #	Description	Cable	Minimum Cable Loss (dB)	Maximum Antenna Gain (dBi)	Net gain (dBi)
SEM244MMF	External antenna	10ft RG174U	-2.5	2.00	-0.5
SEM2MX, SEM2MF	External antenna	10 ft. SEMRC105	-2.3	2.14	-0.16
SEM11MX, SEM11MF	External antenna	10 ft. SEMRC105	-2.3	5.14	2.84
SEM15MX, SEM15MF	External antenna	10 ft. SEMRC105	-2.3	5.14	2.84
SEM2MaX, SEM2MaF	External antenna	11 ft. SEMRC205	-1.2	2.14	0.94
SEM11MaX, SEM11MaF	External antenna	11 ft. SEMRC205	-1.2	5.14	3.94
SEM15MaX, SEM15MaF	External antenna	11 ft. SEMRC205	-1.2	5.14	3.94
SEM2MaXL, SEM2MaFL	External antenna	18 ft. SEMRC205	-2.0	2.14	0.14
SEM11MaXL, SEM11MaFL	External antenna	18 ft. SEMRC205	-2.0	5.14	3.14
SEM15MaXL, SEM15MaFL	External antenna	18 ft. SEMRC205	-2.0	5.14	3.14
SEM2LGMX, SEM2LGMF	External antenna	11 ft. SEMRC205	-1.2	2.14	0.94
SEM11LGMX, SEM11LGMF	External antenna	11 ft. SEMRC205	-1.2	5.14	3.94
SEM15LGMX, SEM15LGMF	External antenna	11 ft. SEMRC205	-1.2	5.14	3.94
SEM26LGMX, SEM26LGMF	External antenna	11 ft. SEMRC205	-1.2	7.14	5.94
SEM2LGMXL, SEM2LGMFL	External antenna	18 ft. SEMRC205	-2.0	2.14	0.14
SEM11LGMXL, SEM11LGMFL	External antenna	18 ft. SEMRC205	-2.0	5.14	3.14
SEM15LGMXL, SEM15LGMFL	External antenna	18 ft. SEMRC205	-2.0	5.14	3.14
SEM26LGMXL, SEM26LGMFL	External antenna	18 ft. SEMRC205	-2.0	7.14	5.14
SEM2THX, SEM2THF	External antenna	14 ft. SEMRC205	-1.5	2.14	0.64
SEM11THX, SEM11THF	External antenna	14 ft. SEMRC205	-1.5	5.14	3.64
SEM15THX, SEM15THF	External antenna	14 ft. SEMRC205	-1.5	5.14	3.64
SEM26THX, SEM26THF	External antenna	14 ft. SEMRC205	-1.5	7.14	5.64
SEM2THXL, SEM2THFL	External antenna	25 ft. SEMRC205	-2.75	2.14	-0.61
SEM11THXL, SEM11THFL	External antenna	25 ft. SEMRC205	-2.75	5.14	2.39
SEM15THXL, SEM15THFL	External antenna	25 ft. SEMRC205	-2.75	5.14	2.39
SEM26THXL, SEM26THFL	External antenna	25 ft. SEMRC205	-2.75	7.14	4.39
SEMD1XL, SEMD1FL	External antenna	18 ft. SEMRC205	-2.0	8.14	6.14
SEMDA2XL, SEMDA2FL	External antenna	18 ft. SEMRC205	-2.0	9.14	7.14

3.8 Part 20.21 § (e)(8)(i)(H) Transmit Power Off Mode.

When the consumer booster cannot otherwise meet the noise and gain limits defined herein it must operate in “Transmit Power OFF Mode.” In this mode of operation, the uplink and downlink noise power shall not exceed -70 dBm/MHz and uplink gain shall not exceed the lesser of 23 dB or MSCL.

This section does not apply because EUT complies with noise and gain limit requirements.

3.9 Part 20.21 § (e)(8)(i)(I) Uplink Inactivity.

When a consumer booster is not serving an active device connection after 5 minutes the uplink noise power shall not exceed -70 dBm/MHz.

3.9.1 Uplink inactivity test procedure

(Reference: KDB #935210 D03, § 7.8)

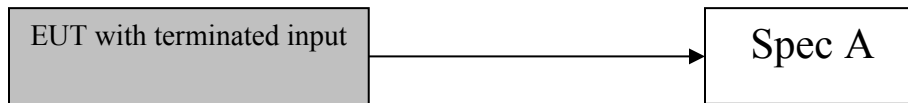
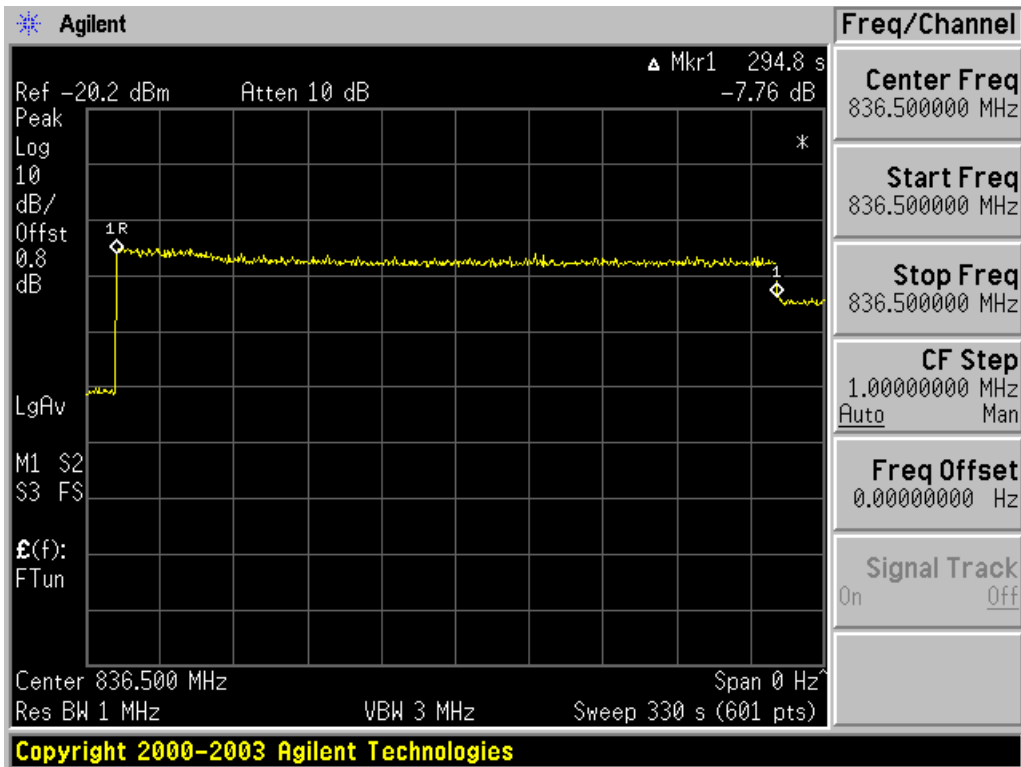


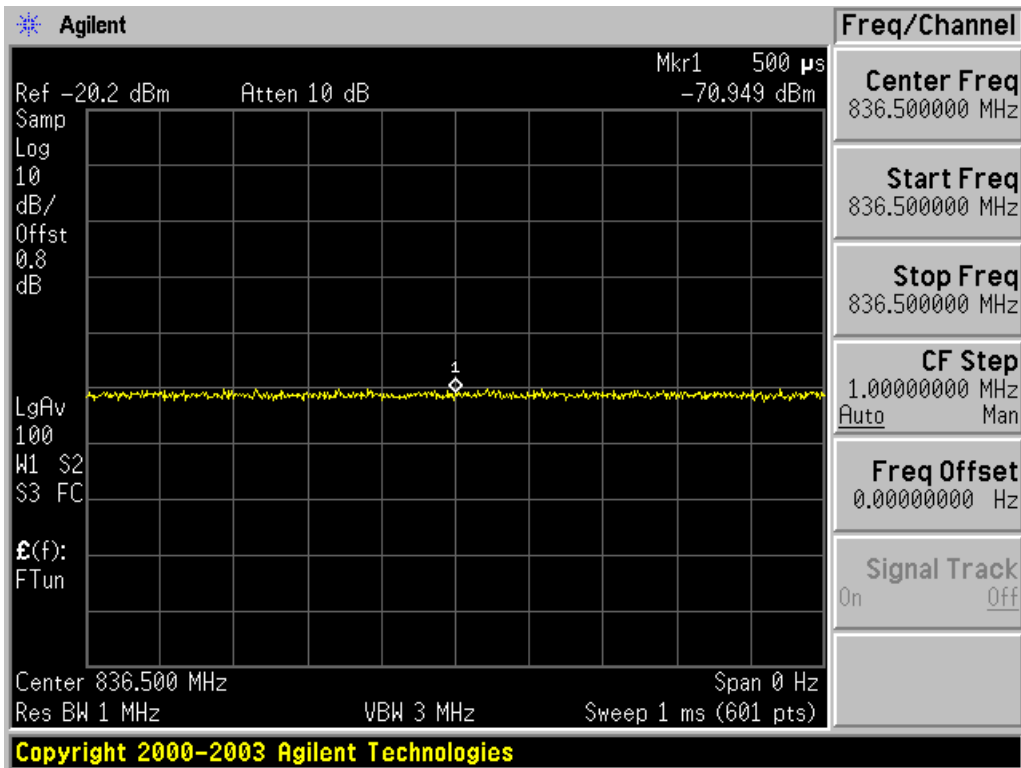
Figure 9: Uplink inactivity test setup

- A. Connect the EUT to the test equipment as shown in Figure 9 with the uplink output connected to the spectrum analyzer.
- B. Select the RMS power averaging detector.
- C. Set the spectrum analyzer RBW for 1 MHz with the VBW $\geq 3X$ RBW.
- D. Set the center frequency of the spectrum analyzer to the center of the uplink operational band.
- E. Set the span for 0 Hz with a single sweep time for a minimum of 330 seconds.
- F. Start to capture a new trace using MAX HOLD.
- G. After approximately 15 seconds turn on the EUT power.
- H. Once the full spectrum analyzer trace is complete place a MARKER on the leading edge of the pulse and use the DELTA MARKER METHOD to measure the time until the uplink was squelched.
- I. Ensure the noise level for the squelched signal is below the uplink inactivity noise power limit, as specified by the rules.
- J. Capture the plot for inclusion in the test report.
- K. Set the spectrum analyzer RBW to 1 MHz with the VBW $\geq 3X$ RBW
- L. Select the power averaging (RMS) detector and trace average over at least 100 traces.
- M. Set the center frequency of the spectrum analyzer to the center of the CMRS band under test with the span $\geq 2X$ the CMRS band.
- N. Measure the maximum Transmitter Noise Power Level.
- O. Save the spectrum analyzer plot as necessary for inclusion in the final test report.
- P. Repeat steps A to O for all operational uplink bands.

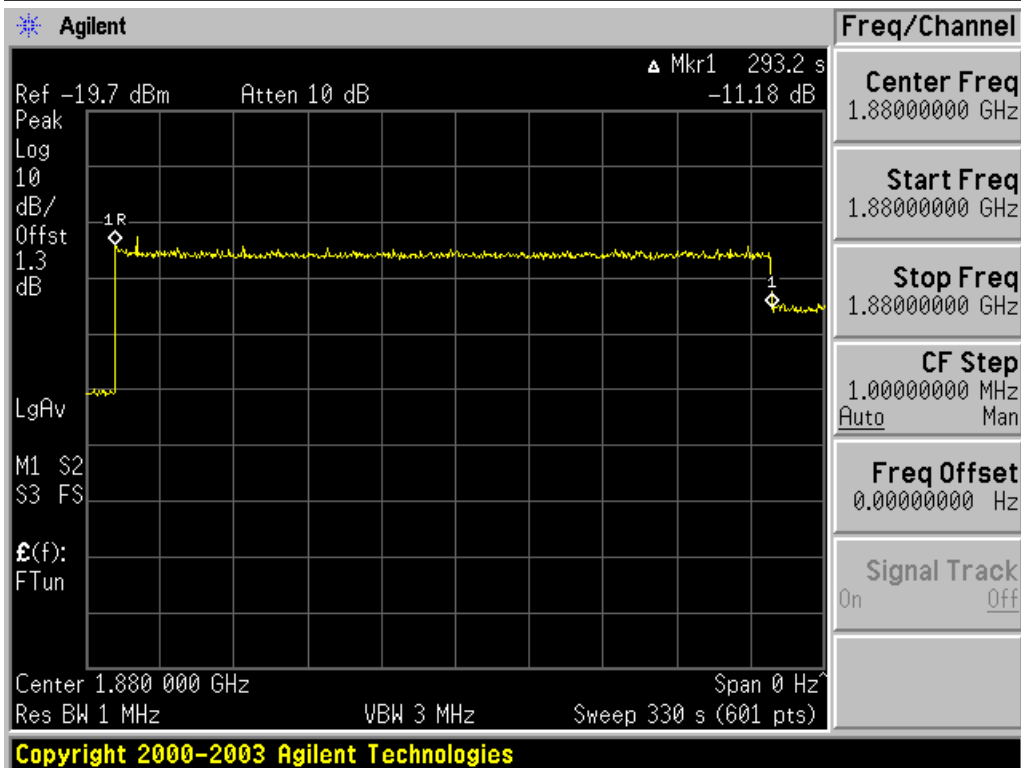
3.9.2 Uplink inactivity test results



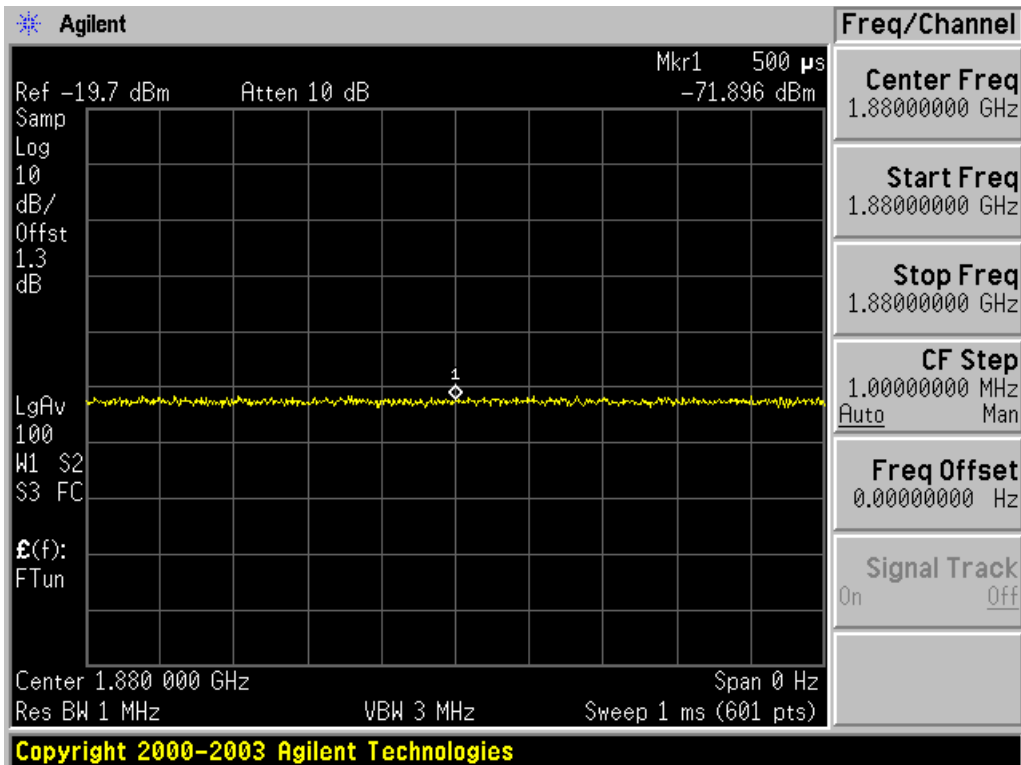
836.5 MHz uplink inactivity timing test



836.5 MHz uplink inactivity noise power test



1880 MHz uplink inactivity timing test



1880 MHz uplink inactivity noise power test

3.10 Part 20.21 § (e)(8)(ii)(A) Anti-Oscillation.

Consumer boosters must be able to detect and mitigate (i.e., by automatic gain reduction or shut down), any oscillations in uplink and downlink bands. Oscillation detection and mitigation must occur automatically within 0.3 seconds in the uplink band and within 1 second in the downlink band. In cases where oscillation is detected, the booster must continue mitigation for at least one minute before restarting. After five such restarts, the booster must not resume operation until manually reset.

3.10.1 Anti-Oscillation test procedure

(In accordance with PBA inquiry #: 942758 alternative test procedure utilized to demonstrate compliance with oscillation detection requirement specified in Part 20.21(e)(8)(ii)(A))

- A. Connect the EUT set for normal operation to the test equipment as shown in Figure 9. Note: bi-directional coupler allow path in both directions, uplink and downlink.

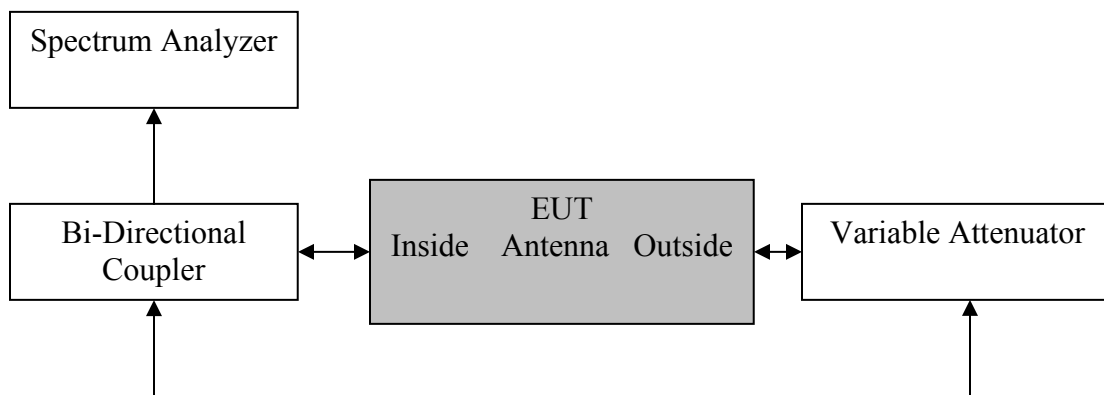
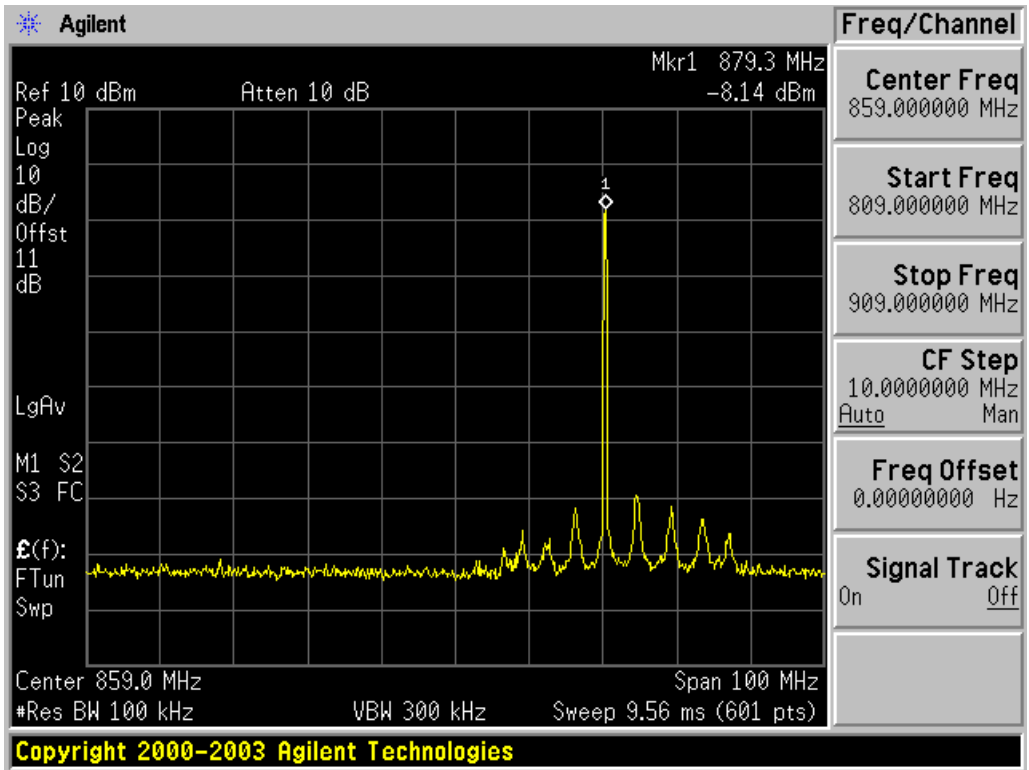


Figure 9

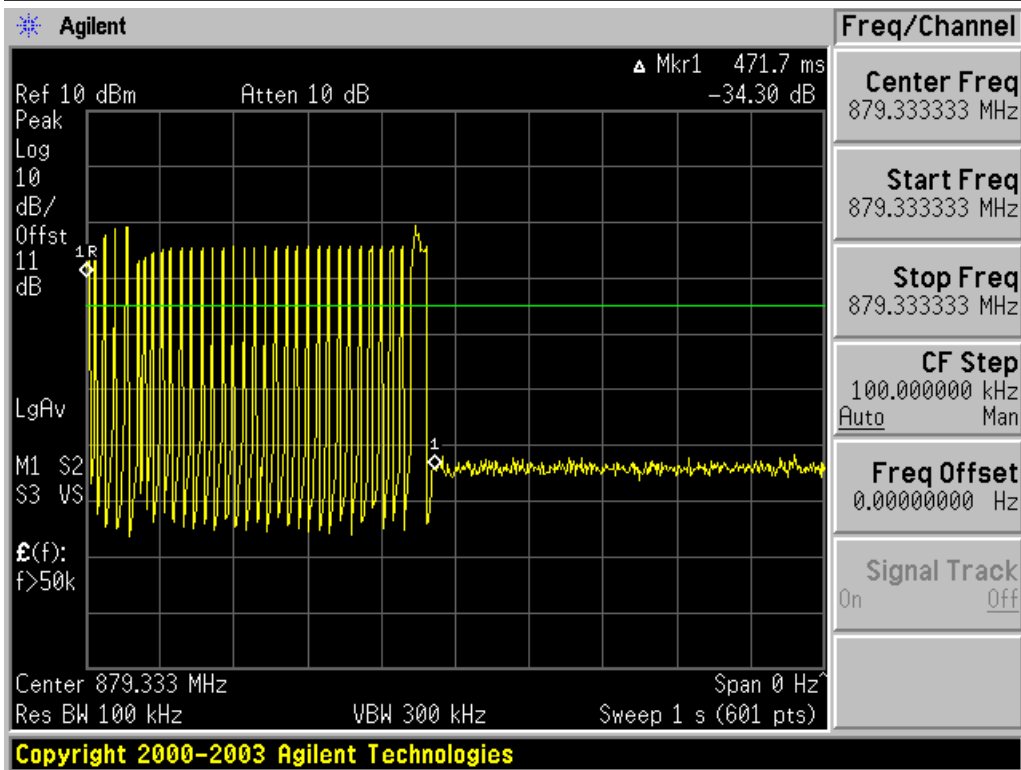
- B. Ensure that the RF coupled path is connected to the spectrum analyzer.
 C. Set the spectrum analyzer frequency to cover uplink and downlink bands of operation.
 D. Set RBW = 100 kHz.
 E. Set VBW \geq 300 kHz.
 F. Utilize the MAX HOLD function of the spectrum analyzer.
 G. Force the EUT to oscillate this will show frequency of oscillation.
 H. Capture the spectrum analyzer trace for inclusion in the test report.
 I. Set the spectrum analyzer centre frequency to frequency of oscillation determined in step G.
 J. Set the span of spectrum analyzer to 0 Hz.
 K. Set single sweep time to 1 s and set for a positive edge trigger and single trigger operation.
 L. Set the attenuation as necessary until the spectrum analyzer triggers and increase the attenuation level to a point 10 dB above that point.

- M. Reset the trigger of the spectrum analyzer and reset the EUT with a power cycle.
- N. Force the EUT to oscillate this will trigger the spectrum analyzer.
- O. Use the DELTA MARKER function of the spectrum analyzer to measure the time from the detection of oscillation until the EUT suppress the oscillation.
- P. Capture the spectrum analyzer trace for inclusion in the test report.
- Q. Set the spectrum analyzer sweep time for a minimum 120 seconds with an AUTO Trigger and a single sweep.
- R. Manually force the booster into oscillation. This will trigger sweep on spectrum analyzer. When the sweep is complete place cursors between the first two oscillation detections and save the plot for inclusion in the test report. The time between restarts must match the manufacturer’s timing for the test mode and there can be no more than 5 restarts.
- S. Repeat steps A to R for all operational bands.

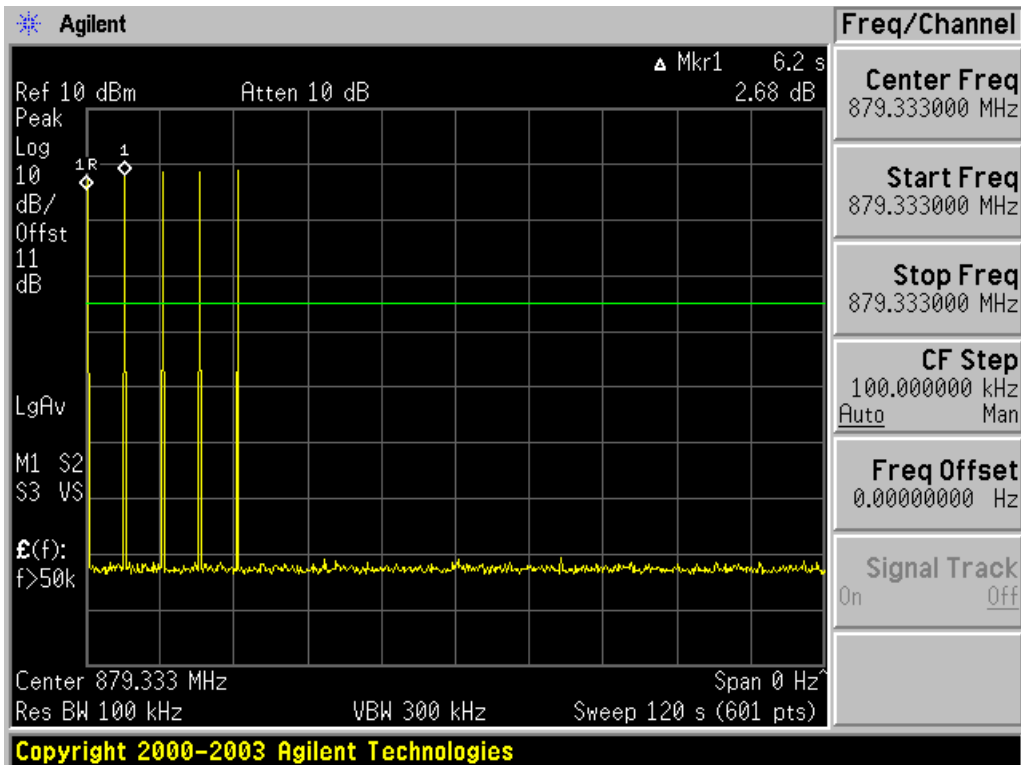
3.10.2 Test results



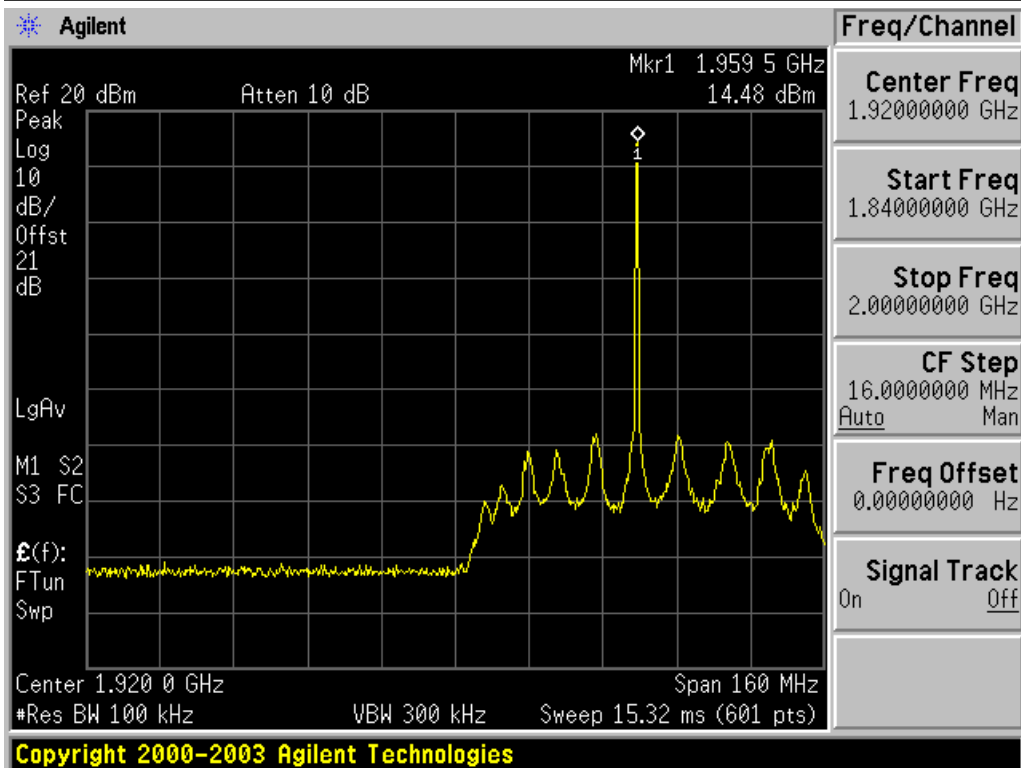
800 MHz band. Frequency of oscillation



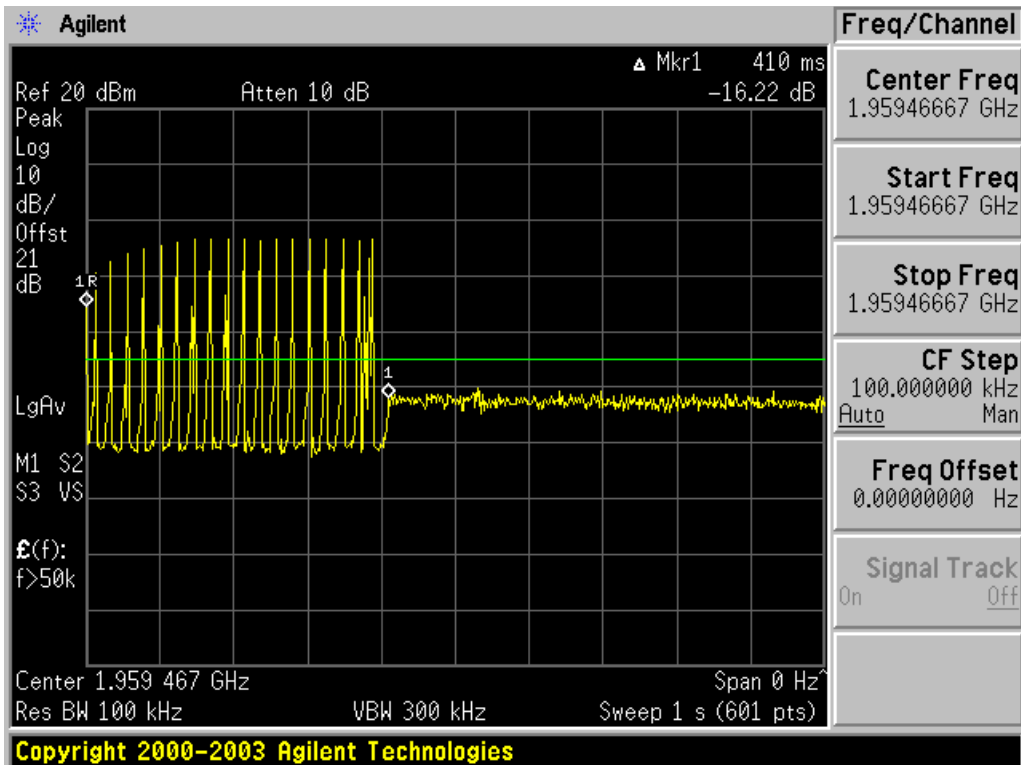
800 MHz band. Oscillation detection and control



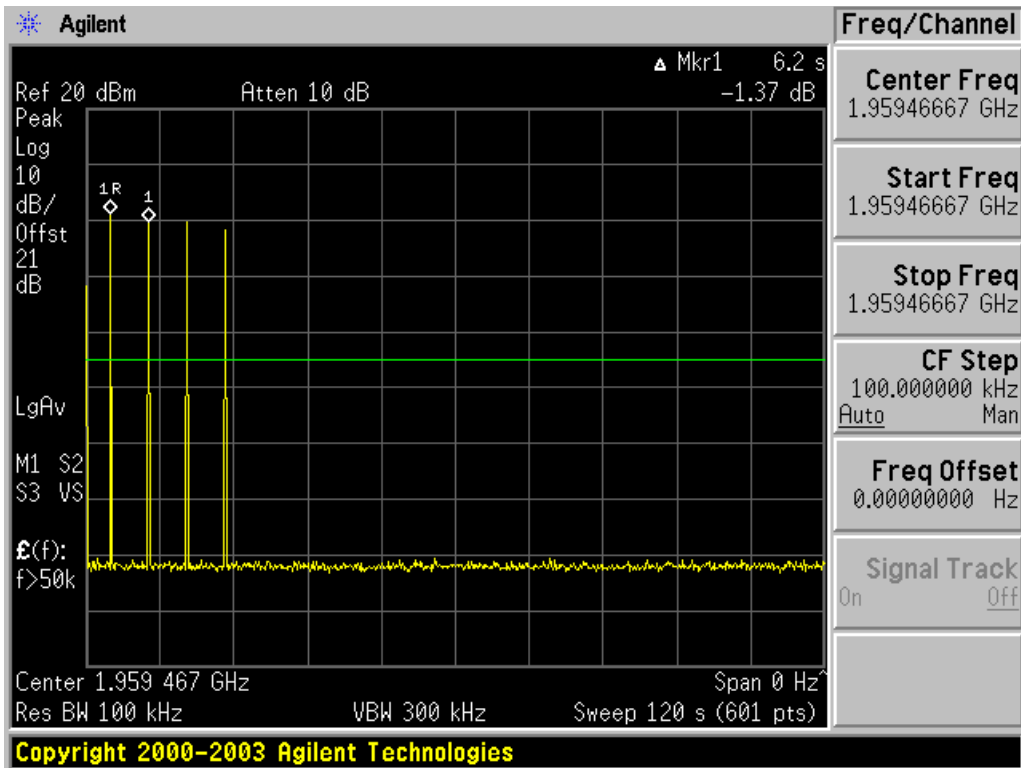
800 MHz band. 120 seconds sweep



1900 MHz band. Frequency of oscillation



1900 MHz band. Oscillation detection and control



1900 MHz band. 120 seconds sweep

3.11 Part 20.21 § (e)(8)(ii)(B) Gain Control.

Consumer boosters must have automatic limiting control to protect against excessive input signals that would cause output power and emissions in excess of that authorized by the Commission.

Refer to test results in Variable booster gain, section 3.3.2 on page 17 of this report.

3.12 Part 2.1049 Occupied Bandwidth.

This measurement is required to compare the uniformity of the output signal relative to the input signal and to satisfy the requirements of §2.1049. (Federal Communications Commission Office of Engineering and Technology Laboratory Division. Publication: 935210 D03)

3.12.1 Occupied bandwidth test procedure

(Reference: KDB #935210 D03, § 7.10)

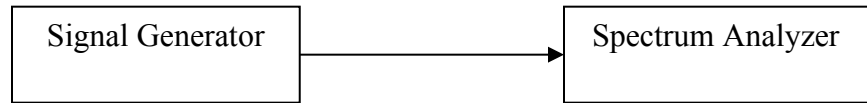


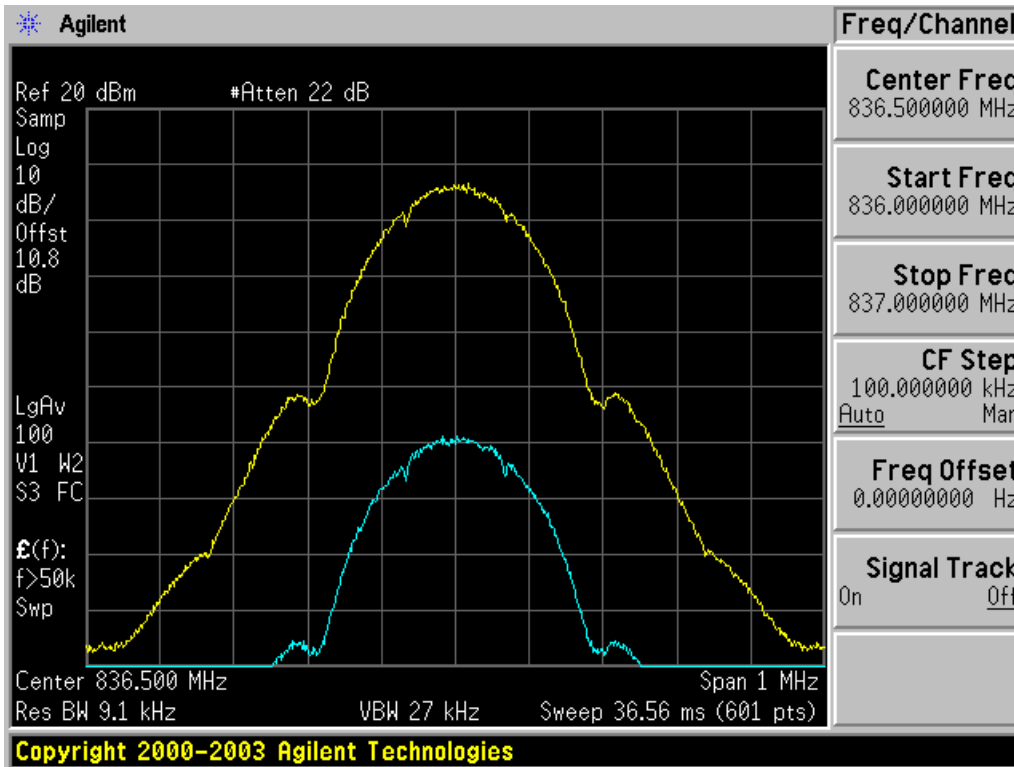
Figure 9



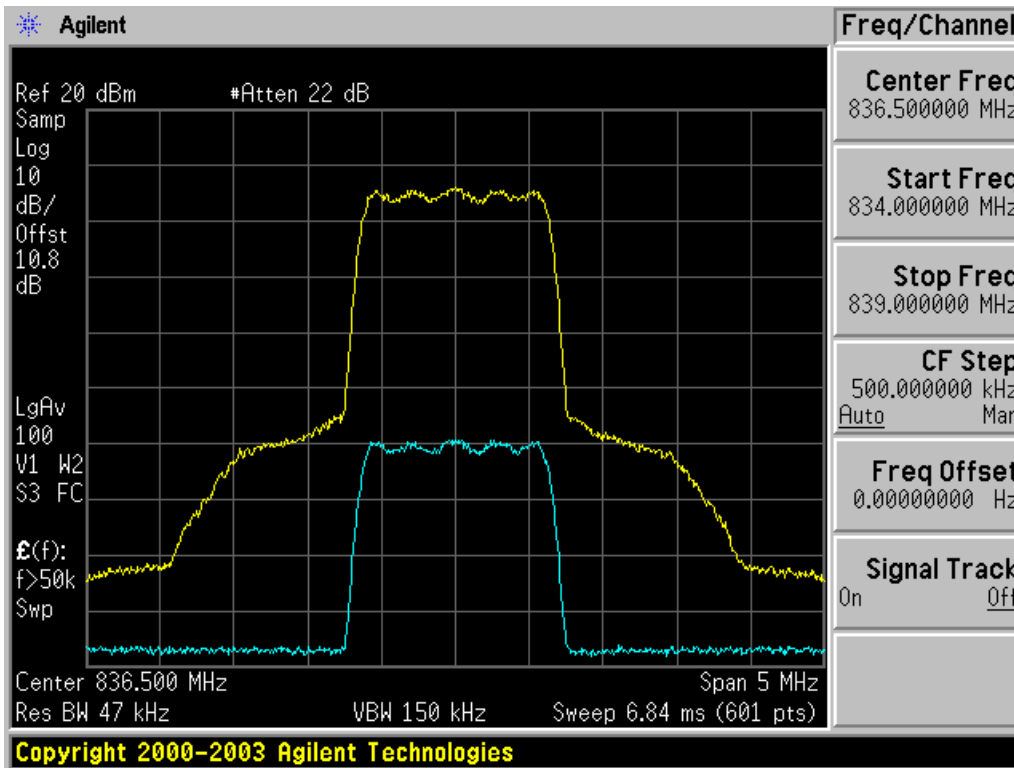
Figure 10

- A. Connect the test equipment as shown in Figure 9 to measure the characteristics of the test signals produced by the signal generator.
- B. Set VBW to $\geq 3X$ RBW
- C. Set the center frequency of the spectrum analyzer to the center of the operational band. The span will be adjusted for each modulation type and occupied bandwidth as necessary for accurately viewing the signals.
- D. Set the signal generator for power level to match the values obtained in section 3.3.4.
- E. Set the signal generator modulation type for GSM with a PBRS pattern and allow the trace on the signal generator to stabilize adjusting the span as necessary.
- F. Set the spectrum analyzer RBW for 1% to 5% of the emissions bandwidth with an RMS AVERAGE detector with at least 100 traces averages..
- G. Save the spectrum analyzer trace for inclusion in the test report.
- H. Connect the test equipment as shown in Figure 10. Turn ON second trace on the spectrum analyzer.
- I. Capture the spectrum analyzer traces for inclusion in the test report. This represents input versus output signal of the EUT.
- J. Repeat steps A to I for CDMA, WCDMA and LTE modulation adjusting the span as necessary for all uplink and downlink operational bands.

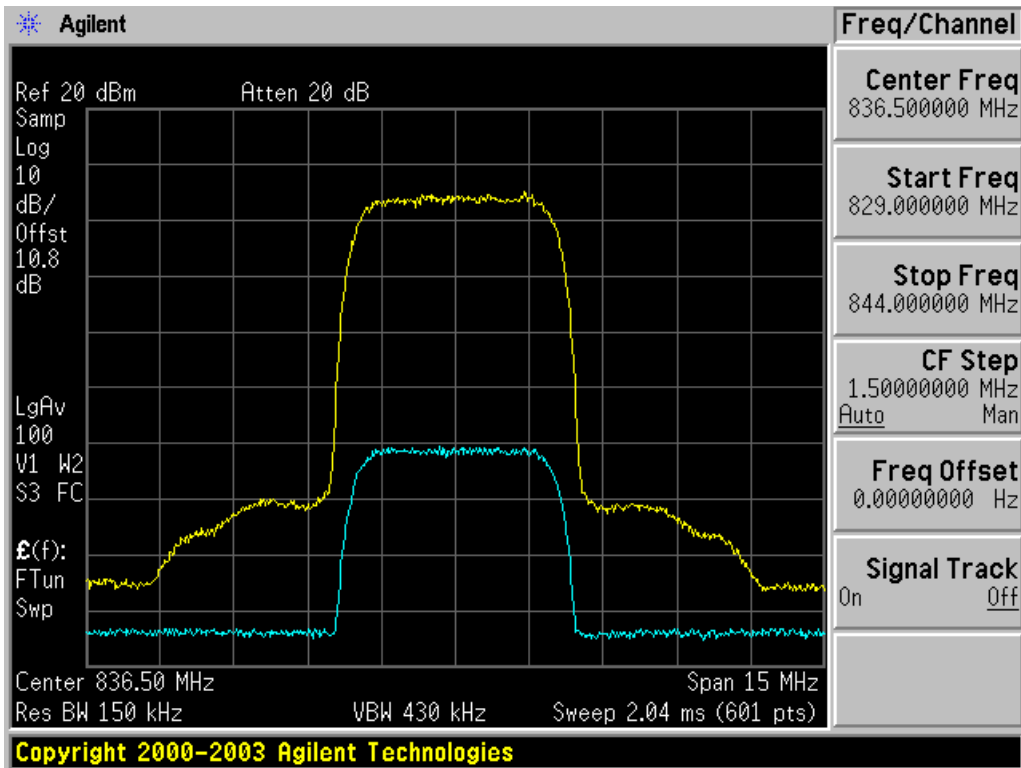
3.12.2 Occupied bandwidth Test Results.



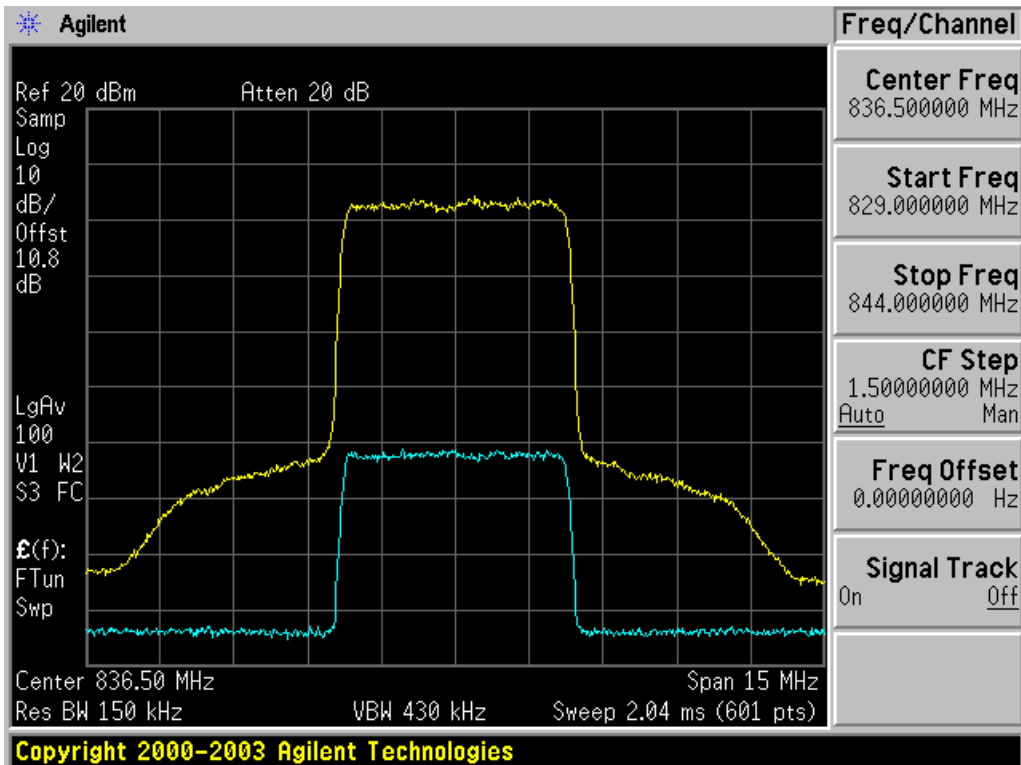
Uplink GSM 836.5 MHz.



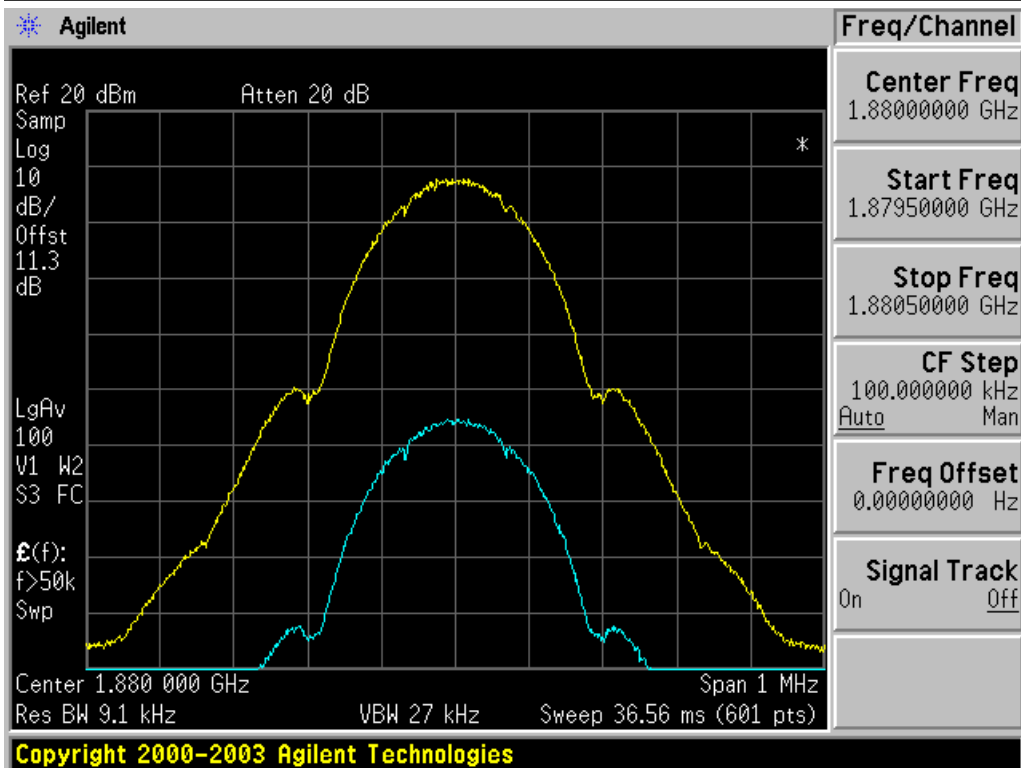
Uplink CDMA 836.5 MHz.



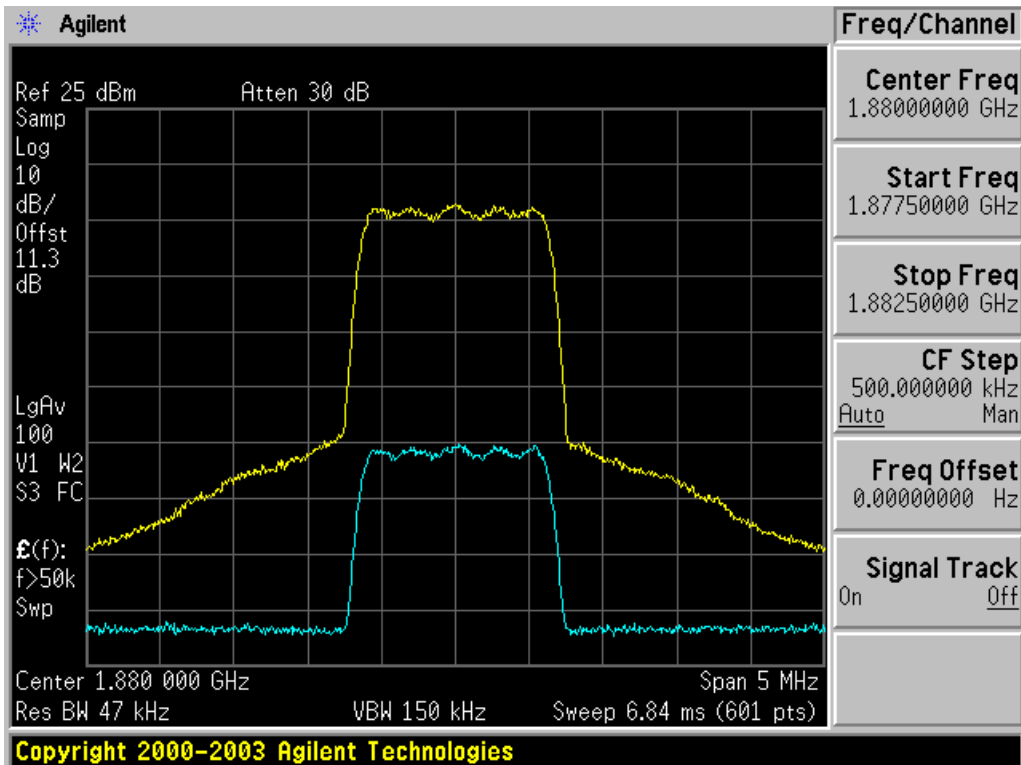
Uplink WCDMA 836.5 MHz.



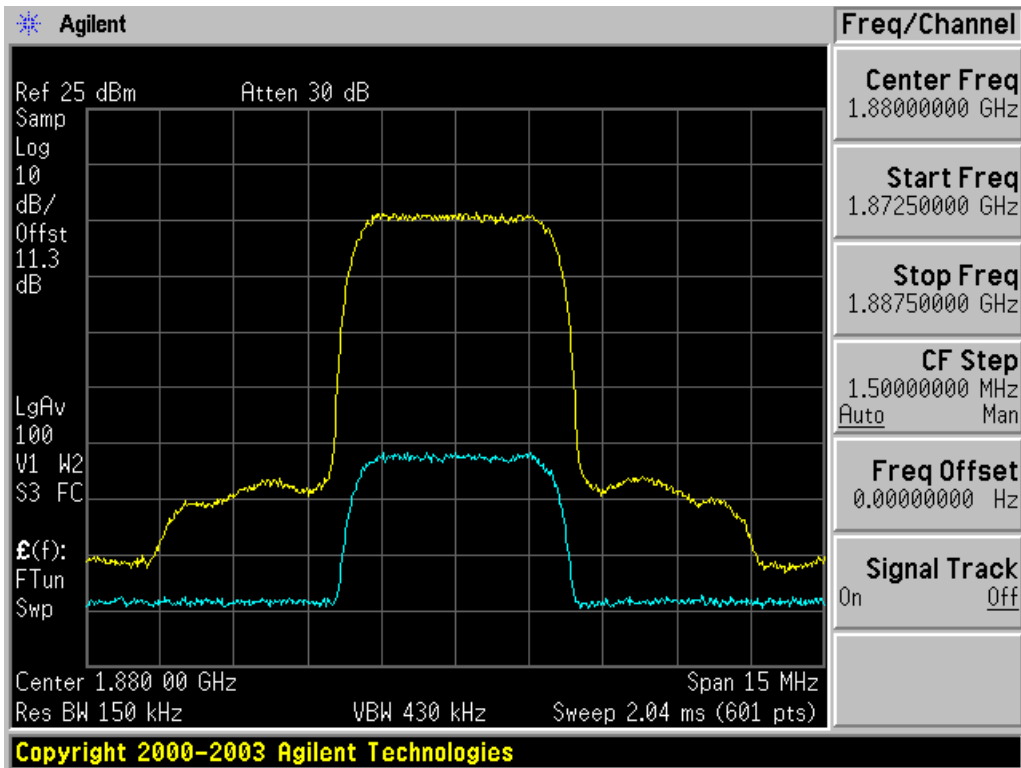
Uplink LTE 836.5 MHz.



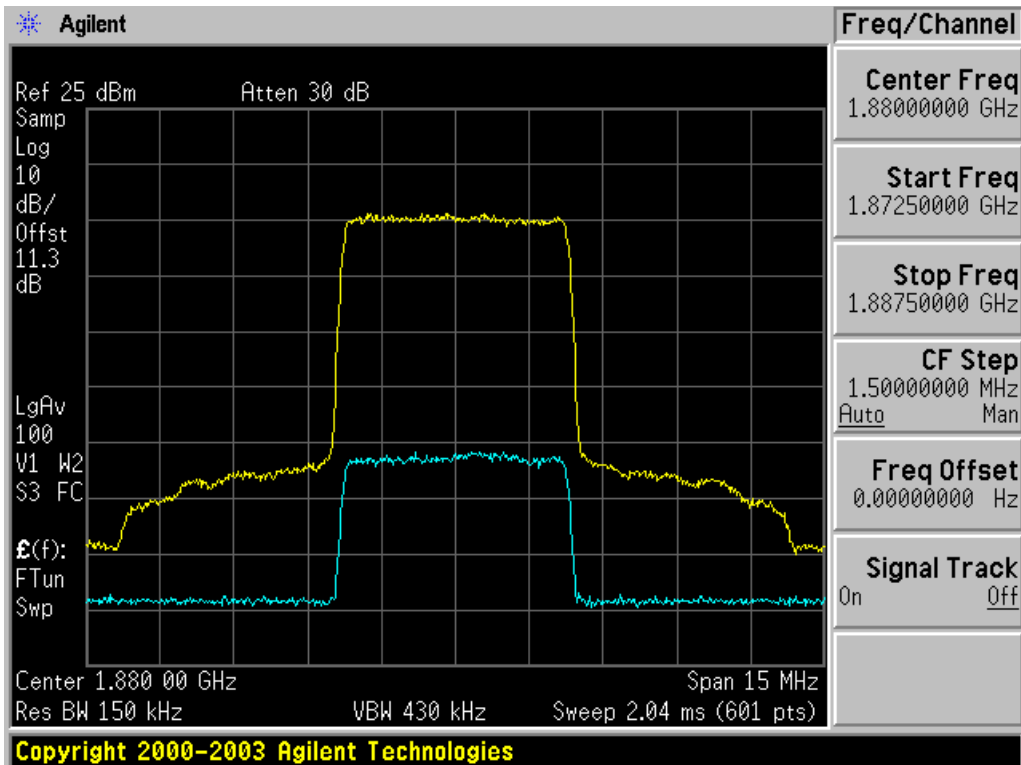
Uplink GSM 1880 MHz.



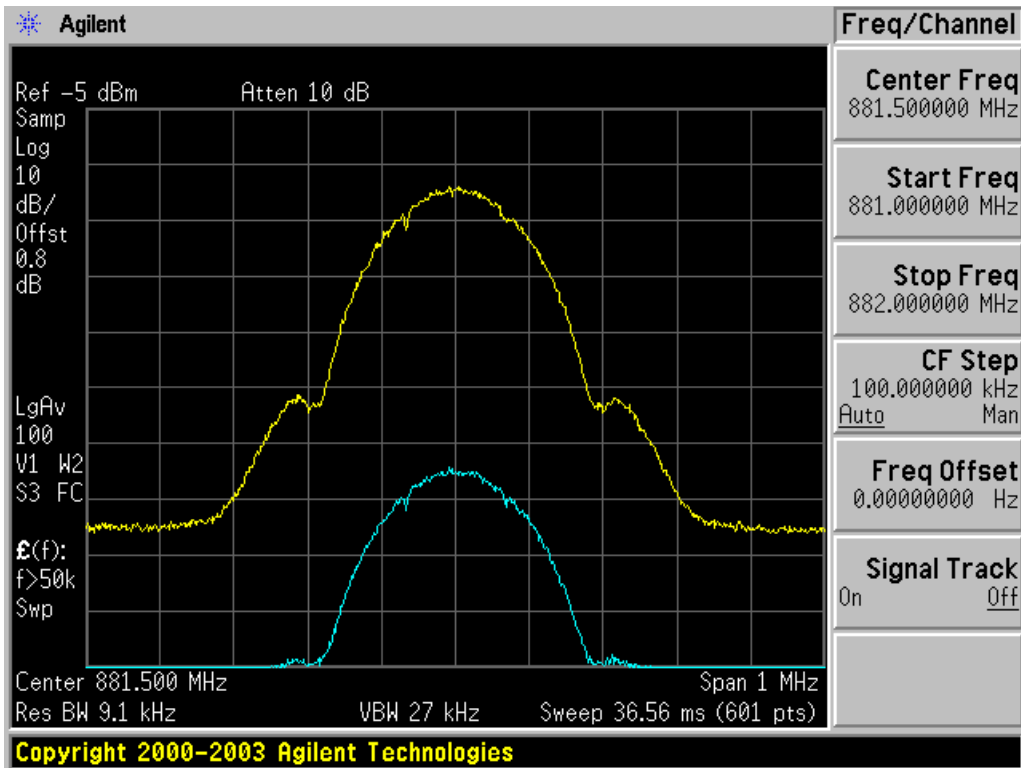
Uplink CDMA 1880 MHz.



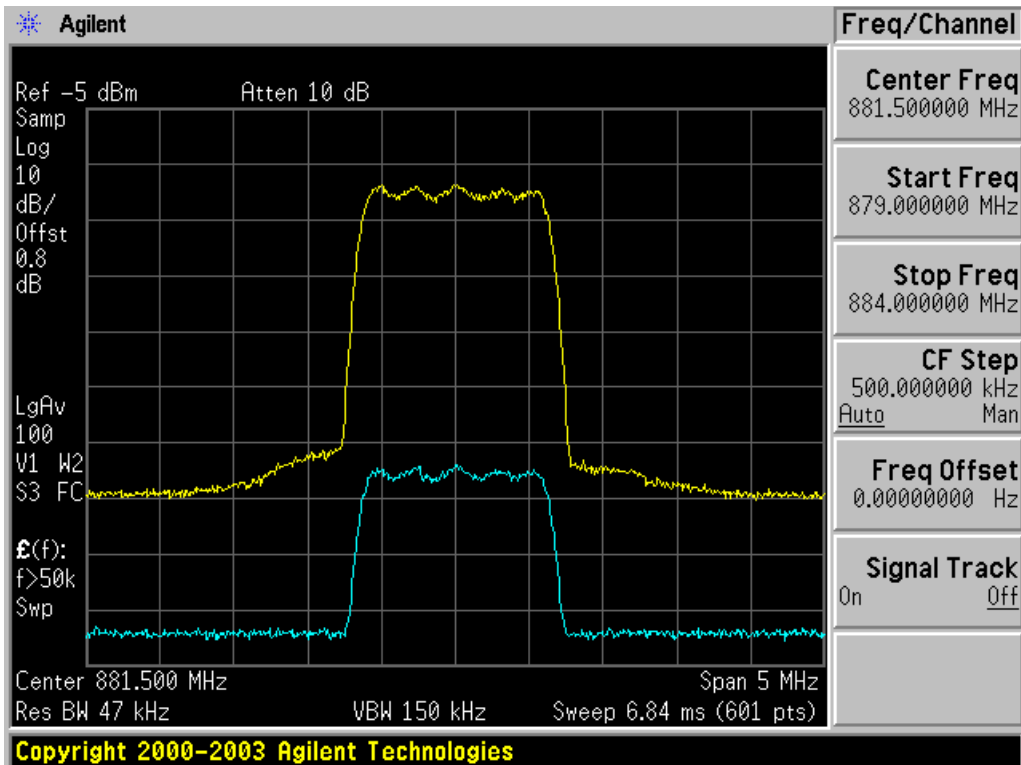
Uplink WCDMA 1880 MHz.



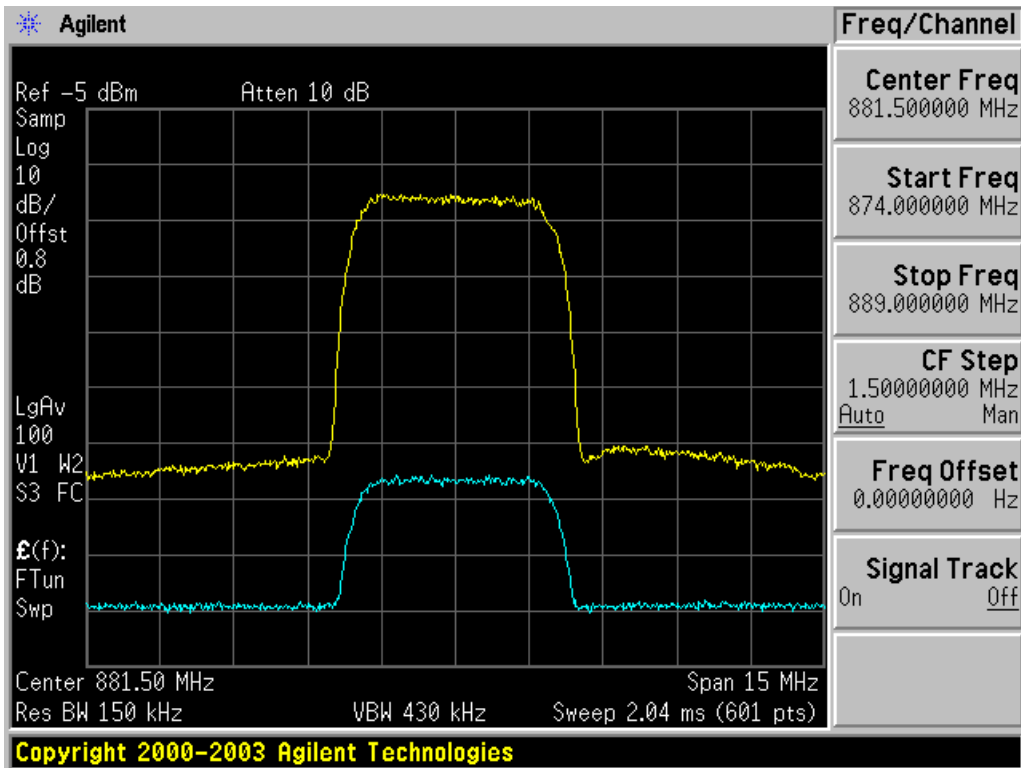
Uplink LTE 1880 MHz.



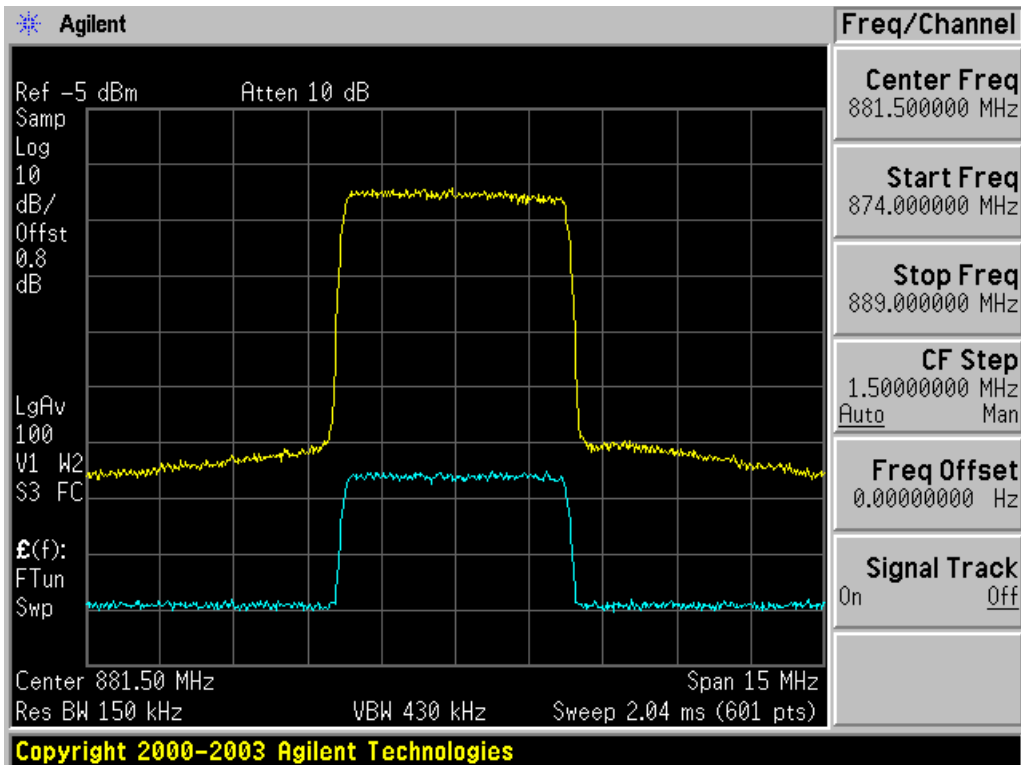
Downlink GSM 881.5 MHz.



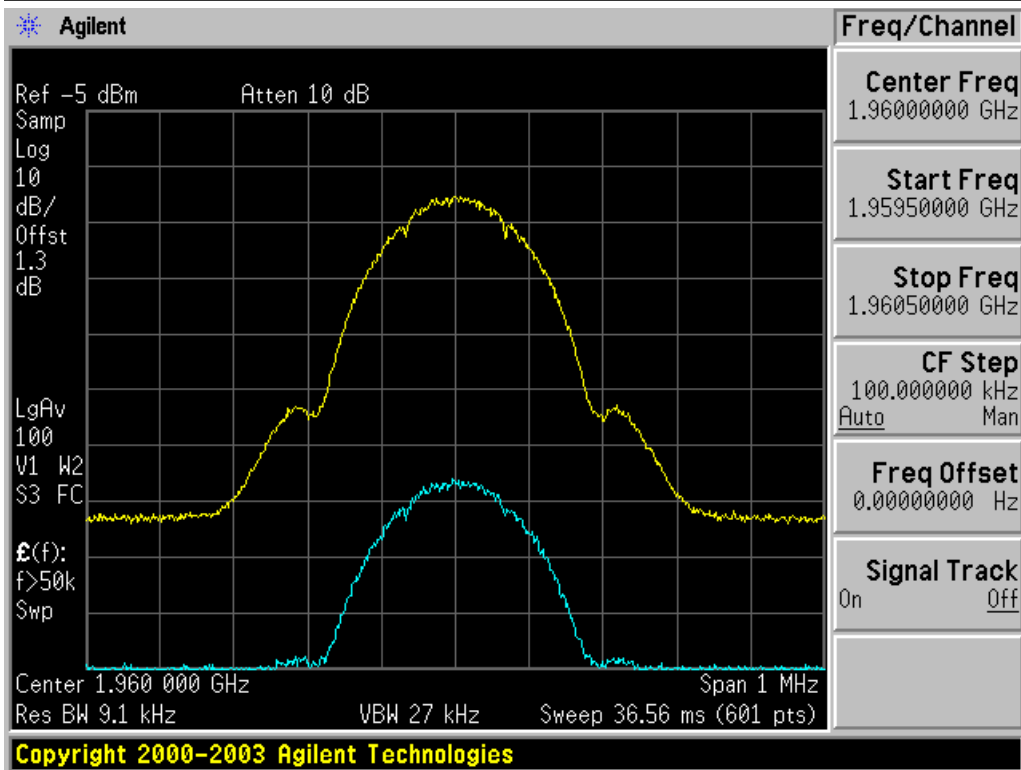
Downlink CDMA 881.5 MHz.



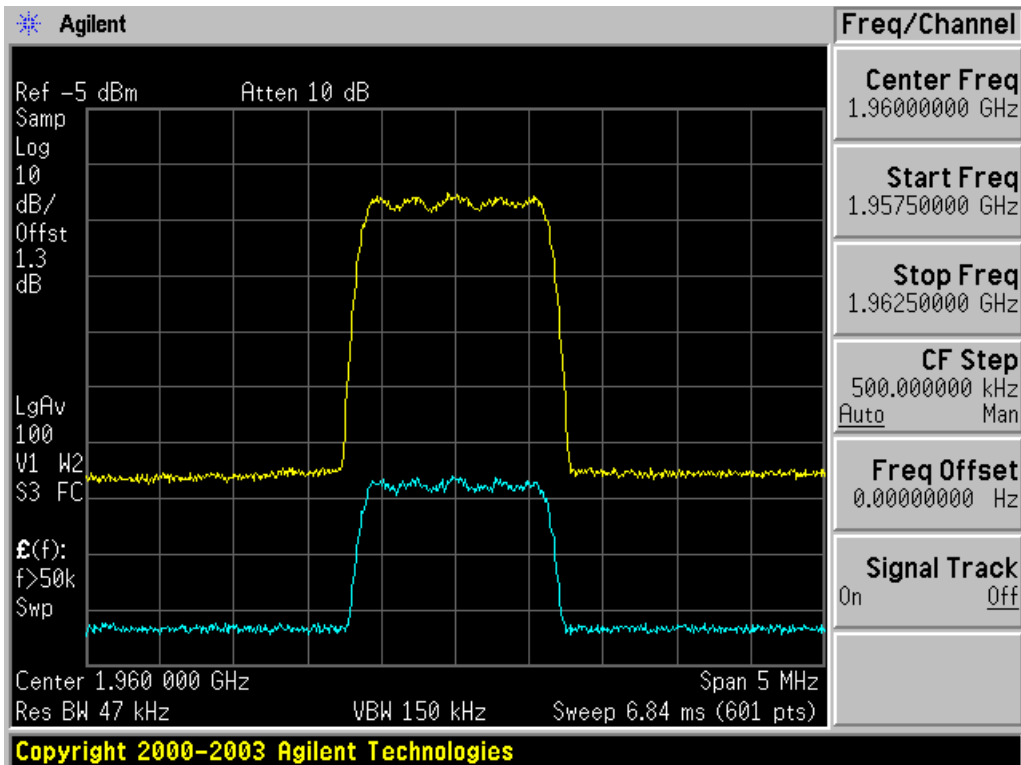
Downlink WCDMA 881.5 MHz.



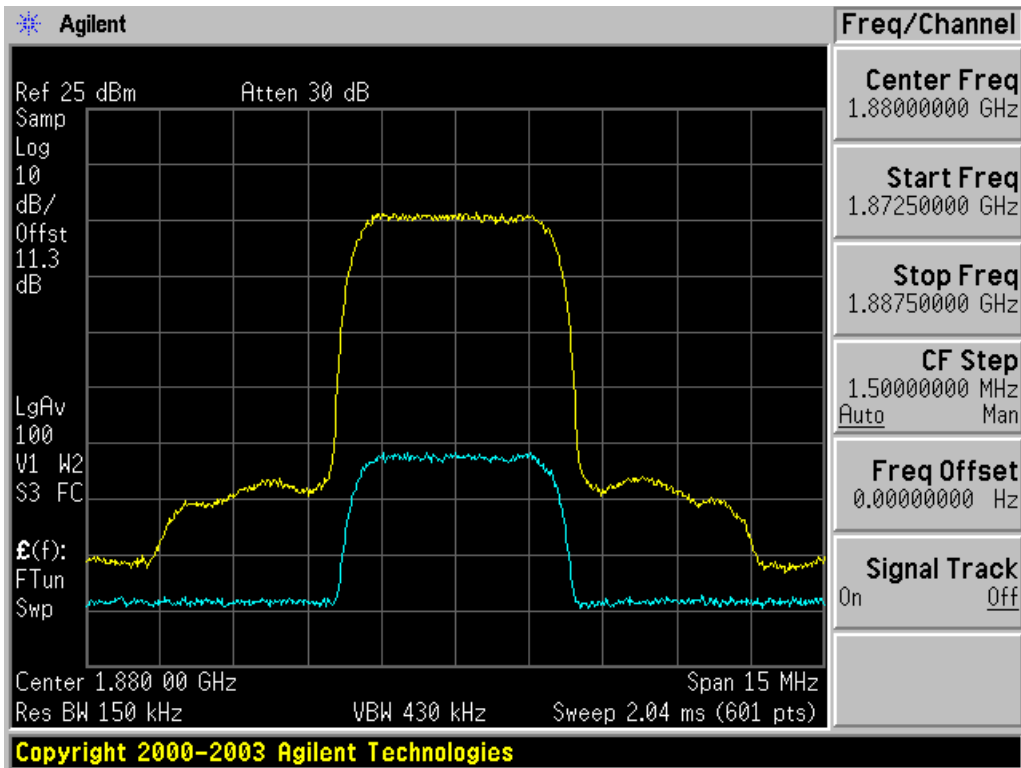
Downlink LTE 881.5 MHz.



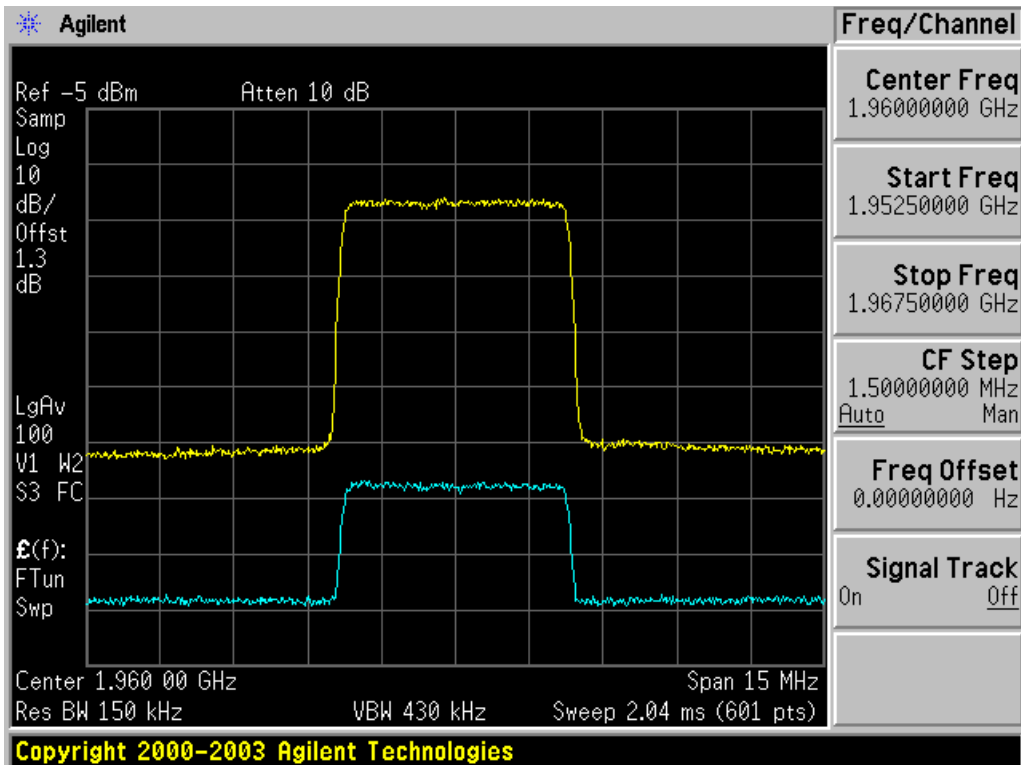
Downlink GSM 1960 MHz.



Downlink CDMA 1960 MHz.



Downlink WCDMA 1960 MHz.



Downlink LTE 1960 MHz.

3.13 Part 2.1053 Radiated Spurious Emissions.

This procedure is intended to satisfy the requirements specified in §2.1053. (Federal Communications Commission Office of Engineering and Technology Laboratory Division. Publication: 935210 D03)

3.13.1 Radiated spurious emissions test procedure

(Reference: KDB #935210 D03, § 7.12)

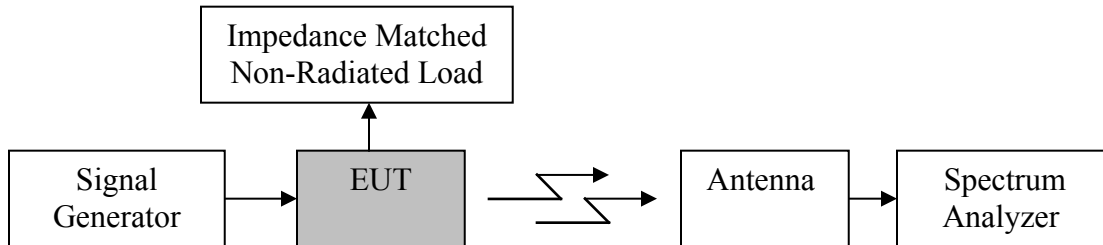


Figure 11

- A. Place the EUT on an OATS or Anechoic chamber turntable 3m from the receiving antenna.
- B. Connect the EUT to the test equipment as shown in Figure 11 beginning with the uplink output.
- C. Set the signal generator for the center frequency of the operational band under test with the power level set at (P_{in}) from section 3.3.4 of this report with CW signal.
- D. Measure the radiated spurious emissions from the EUT from lowest to the highest frequencies as specified in §2.1057.
- E. Capture the peak emissions plots using a peak detector with Maximum Hold for inclusion in the test report. Tabular data is acceptable in lieu of spectrum analyzer plots.
- F. Repeat steps A to E for all operational bands.

3.13.2 Radiated spurious emissions test results.

These tests were performed_BACL and provided on a separate document.

4 MSCL Calculations & Measurements

Test Methodology:

MSCL was calculated using the free air loss calculation. The user manual states the user must keep a separation distance of 3ft. (1 meter) between the booster and the booster server antenna.

Free air loss over a distance of 3ft. at 836 Mhz is >30db. This is the minimum free air loss for the operating bands of the booster.

The server antennas submitted for approval have a maximum net gain of -1.5db. Given the free air loss of 30db added to the server antenna net gain of -1.5db equals 31.5db MSCL, it is considered reasonable that for this submission and test procedures in this report, MSCL of 30db has been used.