

FCC TEST REPORT**FCC Rules Part 20.21****For:**

Mobile Communications, Inc
230 Earl Stewart Dr., Aurora, ON, Canada L4G6V8

FCC ID: S4RBRB81975


Report Type: Original Report	Product Type: Consumer wide-band bi-directional fixed booster
Test Engineer:	Roman Gurvich
Report Number:	BRB81975
Report Date:	March 10, 2014
Prepared By: Roman Gurvich	Signature:  NAME: Roman Gurvich TITLE: RF Engineer

Table of Contents

1	GENERAL INFORMATION.....	4
1.1	Product Description Equipment Under Test (EUT).....	4
1.2	Mechanical Description	4
1.3	Objective	4
1.4	Test Methodology	4
1.5	Measurement Uncertainty	5
1.6	Test Facility	5
1.7	Test Equipment	5
2	Summary of Test Results	6
2.1	Rules Applied.....	6
2.2	Notes	6
3	Test Report.....	7
3.1	Authorized Frequency Band Verification Test.....	7
3.1.1	Authorized frequency band test procedure	7
3.1.2	Authorized frequency band test results.....	8
3.2	Maximum Power Measurement Test	11
3.2.1	Maximum power measurement test procedure	11
3.2.2	Maximum power test results.....	12
3.3	Maximum Booster Gain Computation.....	13
3.3.1	Maximum gain calculation procedure	13
3.3.2	Maximum gain test results	13
3.4	Intermodulation Product Test	14
3.4.1	Intermodulation product test procedure	14
3.4.2	Intermodulation product test results.....	15
3.5	Out-Of-Band Emissions Test.....	18
3.5.1	Out of band emissions test procedure	18
3.5.2	Out of band emissions test results.....	19
3.6	Conducted Spurious Emissions Test.....	36
3.6.1	Conducted spurious emissions test procedure	36
3.6.2	Conducted spurious emissions test results.....	37
3.7	Noise Limits Test.....	42
3.7.1	Noise power in the presence of a downlink signal test procedure.....	42
3.7.2	Test results for noise power in presence of downlink signal	43
3.7.3	Maximum noise power test procedure	44
3.7.4	Maximum noise power test results	45
3.7.5	Uplink noise power timing test procedure.....	47
3.7.6	Uplink noise power timing test results.....	47
3.8	Uplink Inactivity Test	49
3.8.1	Uplink inactivity test procedure.....	49
3.8.2	Uplink inactivity test results	50
3.9	Variable Booster Gain Test.....	53
3.9.1	Variable booster gain test procedure.....	53
3.9.2	Variable booster gain test results	54

3.9.3 Variable uplink gain timing test procedure..... 54

3.9.4 Variable uplink gain timing test results 55

3.10 Occupied Bandwidth Test..... 57

3.10.1 Occupied bandwidth test procedure..... 57

3.10.2 Occupied bandwidth Test Results..... 58

3.11 Oscillation Detection Test..... 74

3.11.1 Anti-Oscillation test procedure 74

3.11.2 Test results 75

3.12 Radiated Spurious Emissions Test..... 79

3.12.1 Radiated spurious emissions test procedure 79

3.12.2 Radiated spurious emissions test results..... 79

4 Booster Antenna Kitting 80

5 MSCL Calculations & Measurements 82

1 GENERAL INFORMATION

1.1 Product Description Equipment Under Test (EUT)

This test and measurement report has been compiled on behalf of Mobile Communications, Inc. for product model: BRB819-75 and FCC ID: S4RBRB81975, which will be referred to in this report as the EUT (Equipment Under Test). The EUT is a Cellular/PCS Consumer wide-band bi-directional fixed booster.

EUT Description	Dual band, Bi-Directional Wireless Fixed Booster
FCC ID	S4RBRB81975
Operation Frequency	Cellular band: 824-849 MHz, 869-894 MHz PCS band: 1850-1910 MHz, 1930-1990 MHz
Modulations	CDMA, WCDMA, LTE, HSPA, GSM, GPRS, EDGE
Type of Equipment	Consumer wide-band bi-directional fixed booster

1.2 Mechanical Description

The EUT measures approximately 190 mm (L) x 90 mm (W) x 25 mm (H), and weighs approximately 350 grams.

1.3 Objective

This type approval report is prepared on behalf of *Mobile Communications, Inc.* in accordance with Part 20.21 of the Federal Communication Commissions rules.

The objective is to determine compliance FCC rules.

1.4 Test Methodology

All tests and measurements indicated in this document were performed at *Mobile Communications, Inc* in accordance with the Code of Federal Regulations Title 20.21.

The “Wideband Consumer Signal Booster Compliance Measurement Guidance”, KDB publication # 935210 D03, was used in test procedure to test EUT.

1.5 Measurement Uncertainty

All measurements involve certain level of uncertainties, especially in the field of EMC. The factors contributing to uncertainties are spectrum analyzer, cable loss, antenna factor calibration and antenna directivity, antenna factor variation with height, antenna phase centre variation, antenna factor frequency interpolation, measurement distance variation, site imperfections, mismatch (average), and system repeatability.

Based on NIS81, The Treatment of Uncertainty in EMC Measurements, the values ranging from ± 2.0 dB for Conducted Emissions tests and ± 4.0 dB for Radiated Emissions tests are the most accurate estimates pertaining to uncertainty of EMC measurements at *Mobile Communications, Inc.*

1.6 Test Facility

The test conducted at *Mobile Communications, Inc* located at 230 Earl Stewart Drive, Aurora, Ontario, Canada, L4G6V8. Conducted emissions measurement data collected and presented in this report.

1.7 Test Equipment

#	Description	Manufacturer	Model No	Serial No	Calibration Date
1	Spectrum Analyzer	Agilent	E4440A	MY46186564	7/16/2013
2	Signal Generator #1	Agilent	E4438C	US41461477	7/12/2013
3	Signal Generator #2	Agilent	E4438C	US41461389	6/25/2013
3	Power Supply	Instek	GPC-3030	9640185	N/A
4	Bi-Directional Coupler	Minicircuits	ZABDC10-25HP	N/A	N/A
5	Bi-Directional Coupler	Minicircuits	ZFBDC20-900HP	N/A	N/A
6	Variable RF Attenuator	Weinschel	905	5396	N/A
7	Fixed RF Attenuator	Weinschel	5W-20	N/A	N/A
8	RF Test Cables	Smoothtalker	SEMRC205	N/A	N/A

2 Summary of Test Results

2.1 Rules Applied

FCC Rules	Description of Tests	Results
§ 20.21 (e)(8)(i)(A)	Noise Limits	Comply
§ 20.21 (e)(8)(i)(B)	Bidirectional Capability	Comply
§ 20.21 (e)(8)(i)(C)	Booster Gain Limits	Comply
§ 20.21 (e)(8)(i)(D)	Power Limits	Comply
§ 20.21 (e)(8)(i)(E)	Out of Band Emission Limits	Comply
§ 20.21 (e)(8)(i)(F)	Intermodulation Limits	Comply
§ 20.21 (e)(8)(i)(G)	Booster Antenna Kitting	Note i
§ 20.21 (e)(8)(i)(H)	Transmit Power OFF Mode	Comply
§ 20.21 (e)(8)(i)(I)	Uplink Inactivity	Comply
§ 20.21 (e)(8)(ii)(A)	Anti-Oscillation	Comply
§ 20.21 (e)(8)(ii)(B)	Gain Control	Comply
§ 20.21 (e)(8)(ii)(C)	Interference Avoidance for Wireless Subsystems	Note ii
§ 2.1049	Occupied Bandwidth	Comply

2.2 Notes

i) EUT user manual specifies all antennas and cables to be used. All technical documentation provided with the application for FCC equipment authorization that shows compliance of all antennas, cables and/or coupling devices with the requirements of this section.

ii) Does not apply to EUT

3 Test Report

3.1 Authorized Frequency Band Verification Test

(Reference: KDB #935210 D03, § 7.1)

Rule paragraph(s):

§ 20.21(e)(3) Frequency Bands. Consumer Signal Boosters must be designed and manufactured such that they only operate on the frequencies used for the provision of subscriber-based services under parts 22 (Cellular), 24 (Broadband PCS), 27 (AWS-1, 700 MHz Lower A-E Blocks, and 700 MHz Upper C Block), and 90 (Specialized Mobile Radio) of this chapter. The Commission will not certificate any Consumer Signal Boosters for operation on part 90 of this chapter (Specialized Mobile Radio) frequencies until the Commission releases a public notice announcing the date Consumer Signal Boosters may be used in the band.

§ 20.21(a)(4) The subscriber operates the Consumer Signal Booster on frequencies used for the provision of subscriber-based services under parts 22 (Cellular), 24 (Broadband PCS), 27 (AWS-1, 700 MHz Lower A-E Blocks, and 700 MHz Upper C Block), and 90 (Specialized Mobile Radio) of this chapter. Operation on part 90 (Specialized Mobile Radio) frequencies is permitted upon the Commission's release of a public notice announcing the date Consumer Signal Boosters may be used in the band.

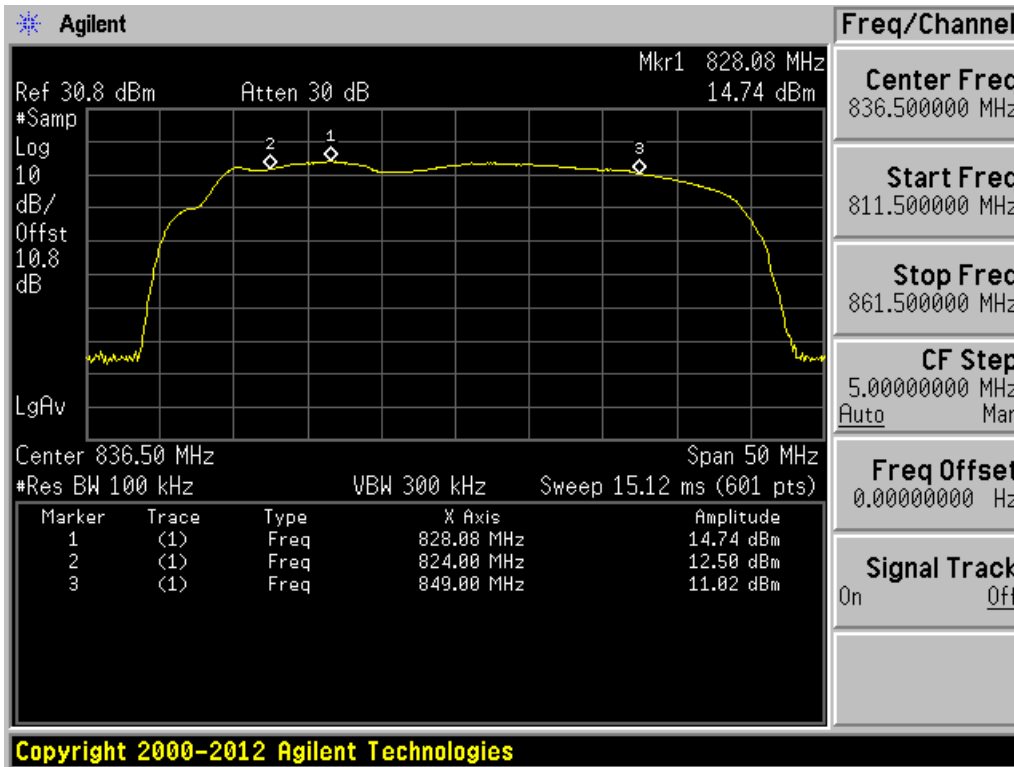
3.1.1 Authorized frequency band test procedure

- A. *Connect the EUT to the test equipment as shown in Figure 1. Begin with the uplink output connected to the spectrum analyzer.*
- B. *Set the spectrum analyzer RBW for 100 kHz with the VBW $\geq 3X$ the RBW using a PEAK detector with the MAX HOLD function.*
- C. *Set the center frequency of the spectrum analyzer to the center of the operational band under test with a span of 1 MHz.*
- D. *Set the signal generator for CW mode and tune to the center frequency of the operational band under test.*
- E. *Set the signal generator power to a level 3 dB below the AGC level without triggering the AGC.*
- F. *Reset the spectrum analyzer span to 2 x the CMRS band under test. Adjust the tuned frequency of the signal generator to sweep 2 times the CMRS band using the sweep function. Note: The AGC must not be activated throughout entire sweep.*
- G. *Using three markers identify the CMRS band edges and the frequency with the highest power. Ensure that the values of all markers are visible on the display of the spectrum analyzer (e.g., marker table set to on).*
- H. *Capture the spectrum analyzer trace for inclusion in the test report.*
- I. *Repeat steps C to H for all operational uplink and downlink bands.*

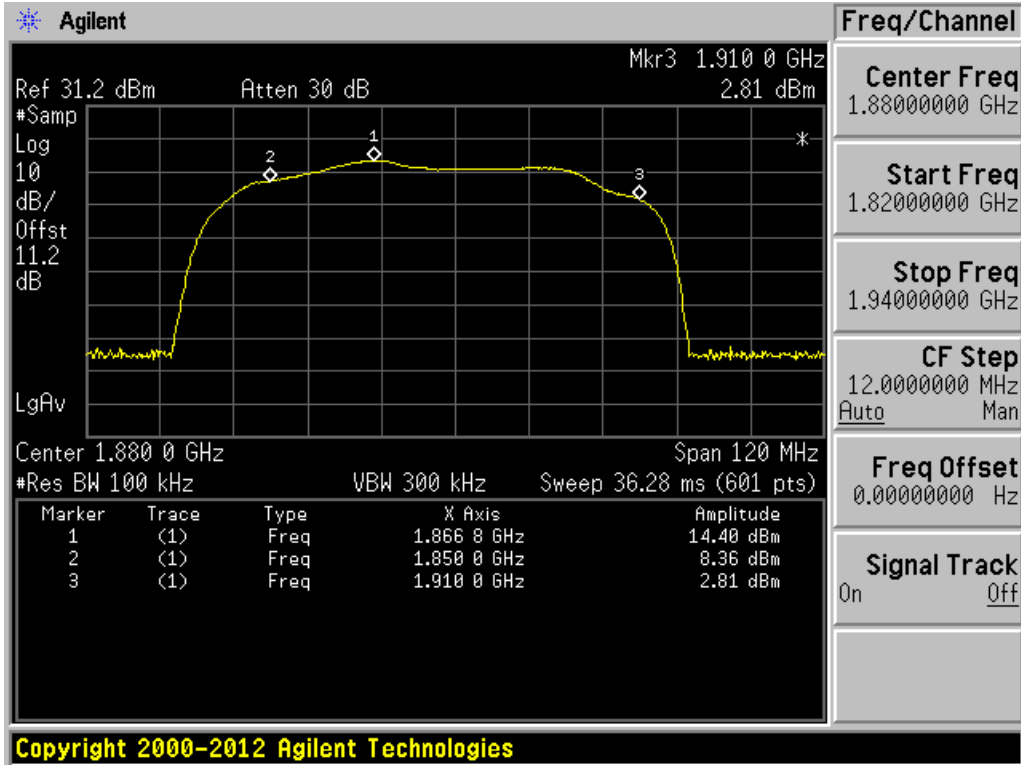


Figure 1

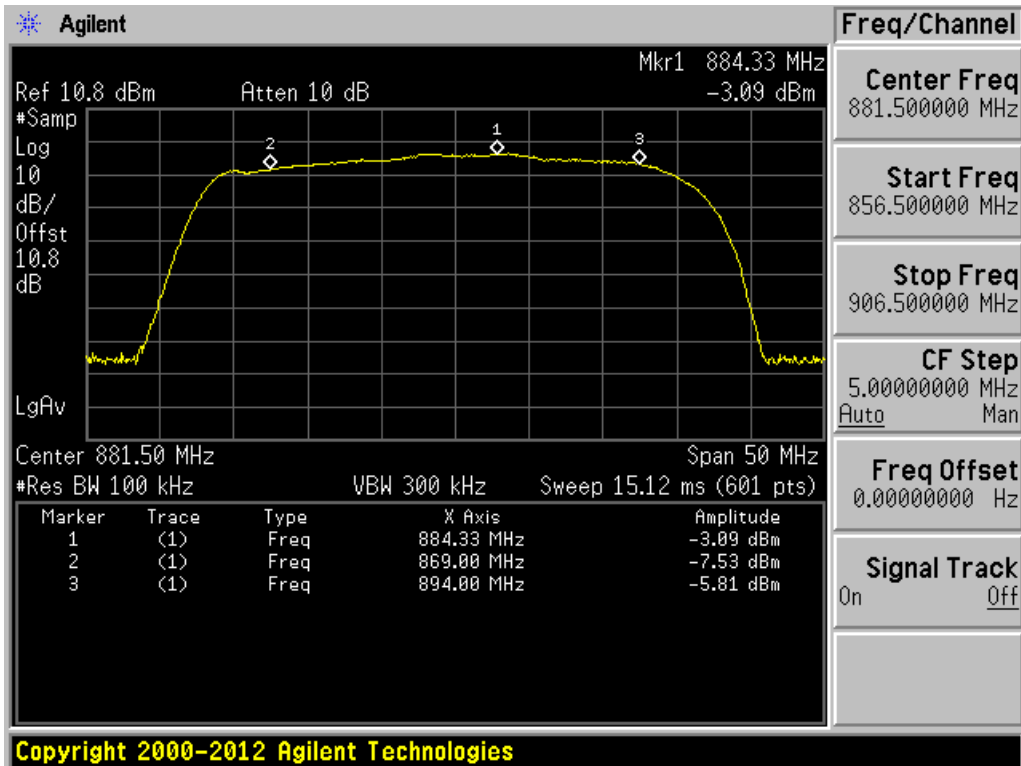
3.1.2 Authorized frequency band test results



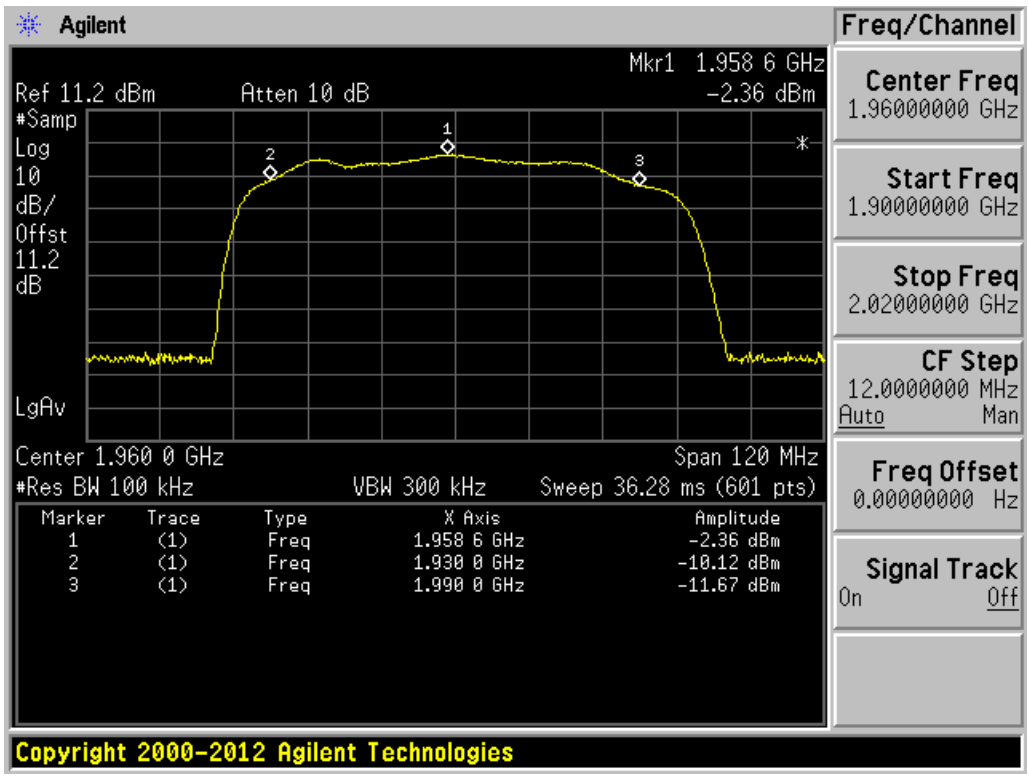
Uplink 800 MHz band



Uplink 1900 MHz band



Downlink 800 MHz band



Downlink 1900 MHz band

3.2 Maximum Power Measurement Test

(Reference: KDB #935210 D03, § 7.2)

Rule paragraph(s):

§ 20.21(e)(8)(i)(D) *Power Limits.* A booster's uplink power must not exceed 1 watt composite conducted power and equivalent isotropic radiated power (EIRP) for each band of operation. Composite downlink power shall not exceed 0.05 watt (17 dBm) conducted and EIRP for each band of operation. Compliance with power limits will use instrumentation calibrated in terms of RMS equivalent voltage.

§ 20.21(e)(8)(i)(B) *Consumer Boosters must be able to provide equivalent uplink and downlink gain and conducted uplink power output that is at least 0.05 watts (17 dBm).*

3.2.1 Maximum power measurement test procedure

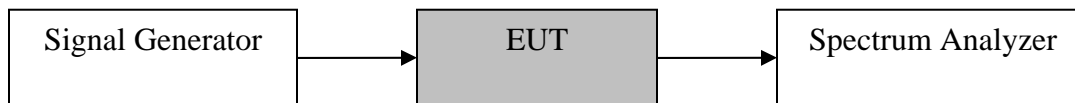


Figure 2

- A. Connect the EUT to the test equipment as shown in figure 2. Begin with the uplink output (donor port) connected to the spectrum analyzer.
- B. Configure the signal generator and spectrum analyzer for operation on the frequency determined in test 3.1 of the highest power level, but with the center frequency of the signal no closer than 2.5 MHz from the band edge. The spectrum analyzer span shall be set to at least 10 MHz.
- C. Use a signal generator to create a pulsed CW or GSM signal with a pulse width of 570 usec and duty cycle of 12.5% (one GSM timeslot) and utilize the burst power function of the spectrum analyzer.
- D. Use a signal generator to create an AWGN signal with a 99% occupied bandwidth of 4.1 MHz and utilize the channel power function of the spectrum analyzer.
- E. Set the initial signal generator power to a level just below (within 0.5 dB of) the AGC limit without triggering the AGC. Note the signal generator power level as (P_{in}).
- F. Set RBW = 100 kHz for AWGN signal type and 300 kHz for CW or GSM signal type.
- G. Set $VBW \geq 3 \times RBW$.
- H. Select either the BURST POWER or CHANNEL POWER measurement tool, as required for each signal type. The channel power integration bandwidth shall be 99% occupied bandwidth (4.1 MHz).
- I. Utilize the RMS (power averaging) detector.
- J. Ensure that the number of measurement points per sweep $\geq (2 \times \text{span})/RBW$
- K. Set sweep time = auto couple, or as necessary.

- L. Set trace average at least 100 traces in power averaging mode.
- M. Record the measured power levels as Pout.
- N. Repeat the procedure A to K for each operational uplink and downlink frequency band supported by the booster.
- O. Provide tabulated results in the test report.

3.2.2 Maximum power test results

Table 1: Burst power (Pulsed CW)

Operational Band	Frequency (MHz)	P out (dBm)	Requirement	Result
800 Tx	828	21.98	> 17 dBm	Pass
800 Rx	884.4	4.2	< 17 dBm	Pass
1900 Tx	1866.8	23.5	> 17 dBm	Pass
1900 Rx	1956.8	-0.6	< 17 dBm	Pass

Table 2: Channel power (AWGN 4.1 MHz)

Operational Band	Frequency (MHz)	P out (dBm)	Requirement	Result
800 Tx	828	21.35	> 17 dBm	Pass
800 Rx	884.4	5.5	< 17 dBm	Pass
1900 Tx	1866.8	23.21	> 17 dBm	Pass
1900 Rx	1956.8	-0.26	< 17 dBm	Pass

3.3 Maximum Booster Gain Computation

(Reference: KDB #935210 D03, § 7.3)

Rule paragraph(s):

§ 20.21(e)(8)(i)(C)(2) *The uplink and downlink maximum gain of a Consumer Booster referenced to its input and output ports shall not exceed the following limits:*

- (i) *Fixed Booster maximum gain shall not exceed $6.5 \text{ dB} + 20 \text{ Log}_{10}(\text{Frequency})$*
- (ii) *Where, Frequency is the uplink mid-band frequency of the supported spectrum bands in MHz.*

§ 20.21(e)(8)(i)(B) *Consumer Boosters must be able to provide equivalent uplink and downlink gain and conducted uplink power output that is at least 0.05 watts (17 dBm).*

3.3.1 Maximum gain calculation procedure

- A. *Calculate the maximum gain of the booster based on measurements obtained from Bi-Directional Capability test.*
- B. *For both the uplink and downlink in each supported frequency band, use each of the Pout and Pin value pairs determined in bi-directional capability test in the following equation to determine the maximum gain (G) of the booster:*

$$G \text{ (dB)} = P_{\text{out}} \text{ (dBm)} - P_{\text{in}} \text{ (dBm)}.$$
- C. *Record the maximum gain of the uplink and downlink paths for each supported frequency band and verify that the each gain value complies with the applicable limit.*
- D. *Provide tabulated results in the test report.*

3.3.2 Maximum gain test results

Table 3: Maximum Booster Gain

Operational Band	P in (dBm)	P out (dBm)	Gain (dB)	Rules (dB)	Result
800 MHz Uplink	-45.0	14.7	59.7	65	Pass
800 MHz Downlink	-68.0	-3.1	64.9	65	Pass
1900 MHz Uplink	-52.0	14.4	66.4	72	Pass
1900 MHz Downlink	-74.0	-2.4	71.6	72	Pass

3.4 Intermodulation Product Test

(Reference: KDB #935210 D03, § 7.4)

Rule paragraph(s):

§ 20.21(e)(8)(i)(F) *Intermodulation Limits.* The transmitted intermodulation products of a consumer booster at its uplink and downlink ports shall not exceed the power level of negative 19 dBm for the supported bands of operation. Compliance with intermodulation limits will use boosters operating at maximum gain and maximum rated output power, with two continuous wave (CW) input signals spaced 600 kHz apart and centered in the pass band of the booster, and with a 3 kHz measurement bandwidth.

3.4.1 Intermodulation product test procedure

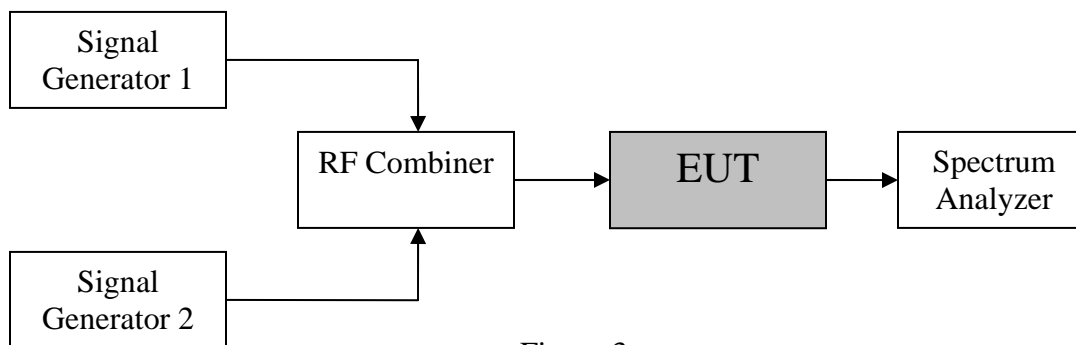
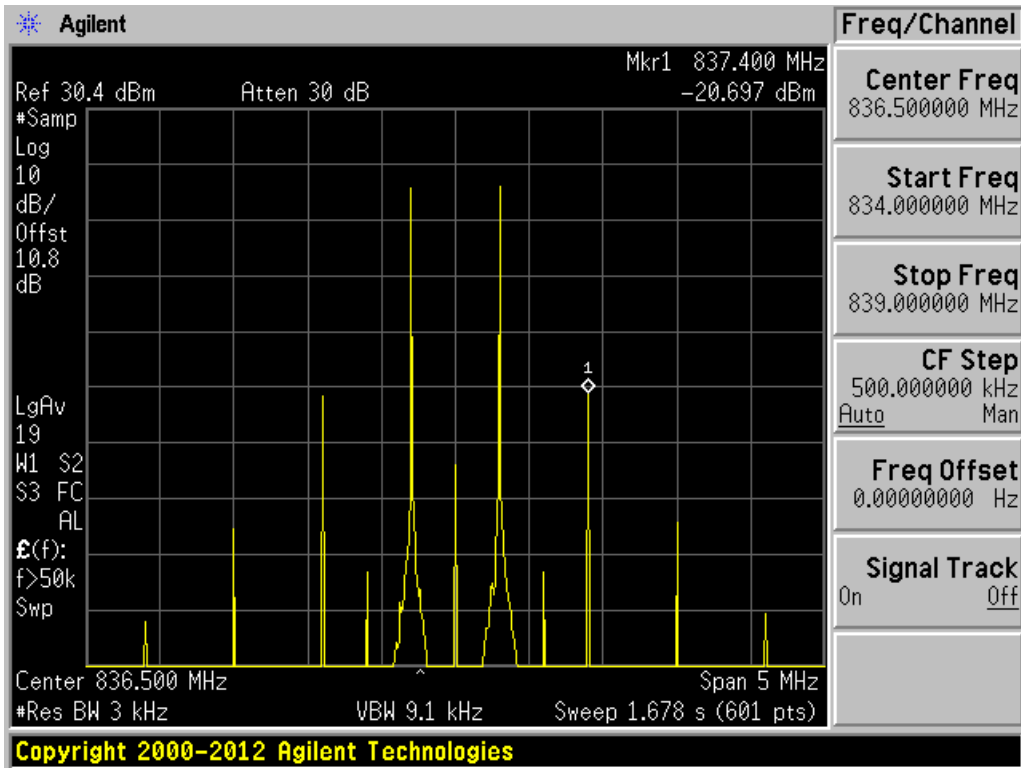


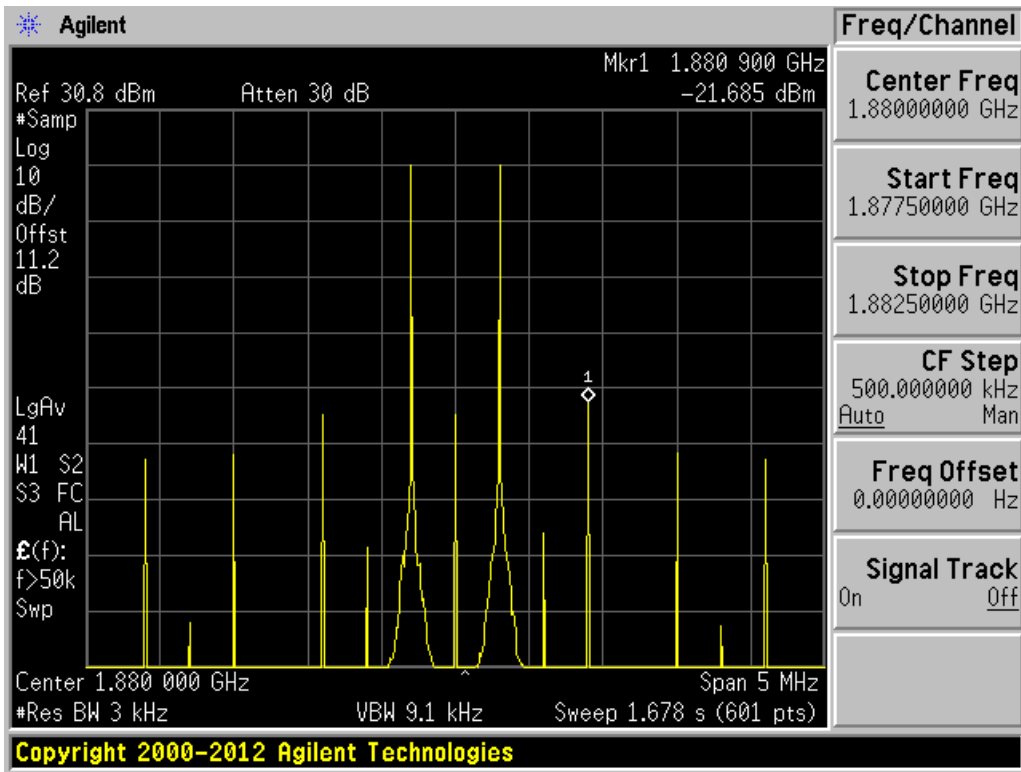
Figure 3

- A. Connect the signal booster to the test equipment as shown in Figure 3. Begin with the uplink output connected to the spectrum analyzer.
- B. Set the spectrum analyzer RBW = 3 kHz.
- C. Set the VBW $\geq 3 \times$ the RBW.
- D. Select the RMS detector.
- E. Set the spectrum analyzer center frequency to the center of the supported operational band under test.
- F. Set the span to 5 MHz.
- G. Configure the two signal generators for CW operation with generator 1 tuned 300 kHz below the operational band center frequency and generator 2 tuned 300 kHz above the operational band center frequency.
- H. Set the signal generator amplitudes so that the power from each into the RF combiner is equivalent and turn on the RF output.
- I. Increase the signal generators' amplitudes equally until just before the EUT begins AGC and ensure that all intermodulation products (if any exist), are below the specified limit of -19 dBm.
- J. Utilize the MAX HOLD function of the spectrum analyzer and wait for the trace to stabilize. Place a marker at the highest amplitude intermodulation product.
- K. Record the maximum intermodulation product amplitude level that is observed.
- L. Capture the spectrum analyzer trace for inclusion in the test report.
- M. Repeat steps A to L for all uplink and downlink operational bands.

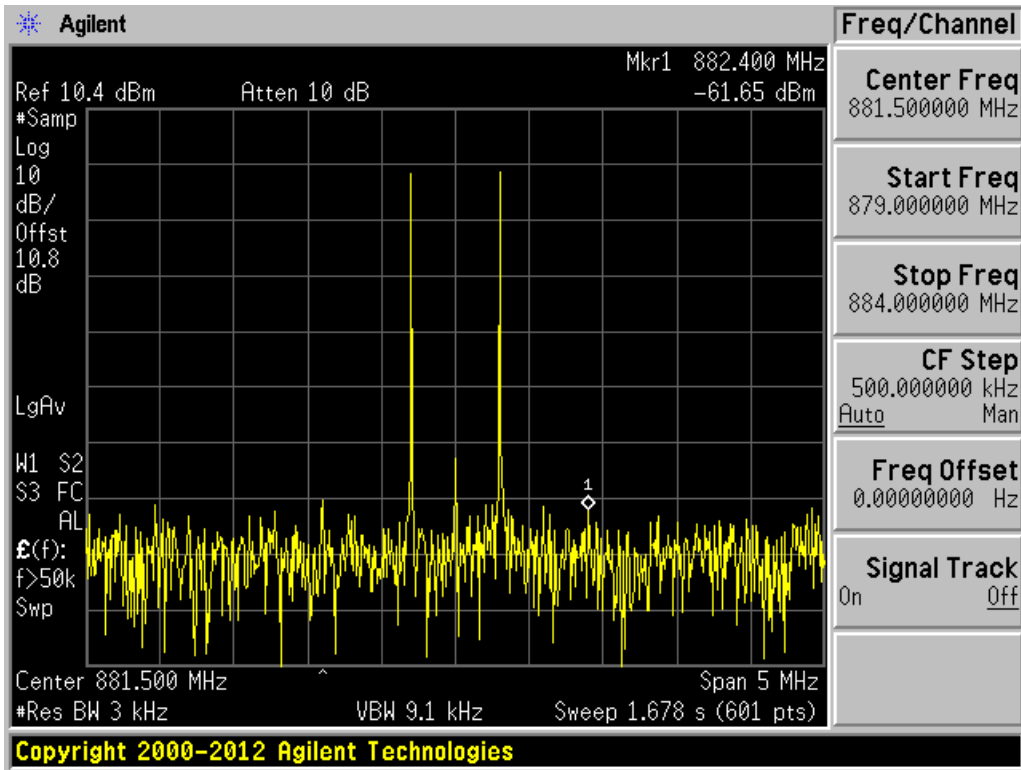
3.4.2 Intermodulation product test results



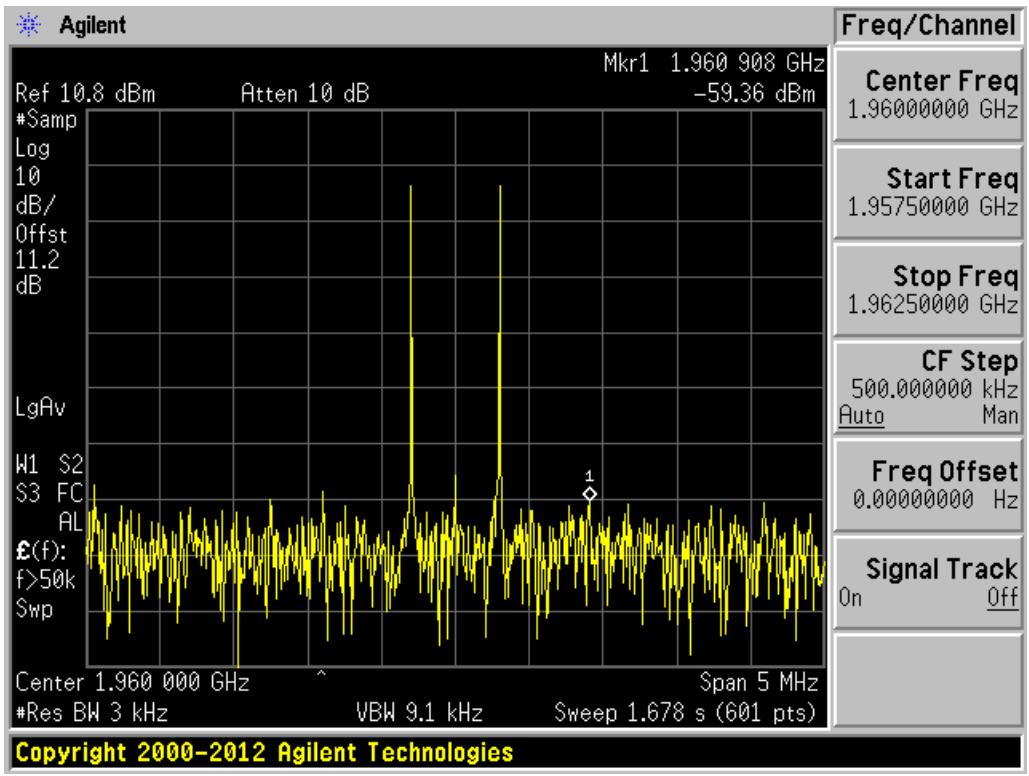
Uplink 836.5 MHz.



Uplink 1880 MHz.



Downlink 881.5 MHz.



Downlink 1960 MHz.

3.5 Out-Of-Band Emissions Test

(Reference: KDB #935210 D03, § 7.5)

Rule paragraph(s):

§ 20.21(e)(8)(i)(E) *Out of Band Emission Limits. Booster out of band emissions (OOBE) shall be at least 6 dB below the FCC's mobile emission limits for the supported bands of operation. Compliance to OOBE limits will utilize high peak-to-average CMRS signal types.*

3.5.1 Out of band emissions test procedure

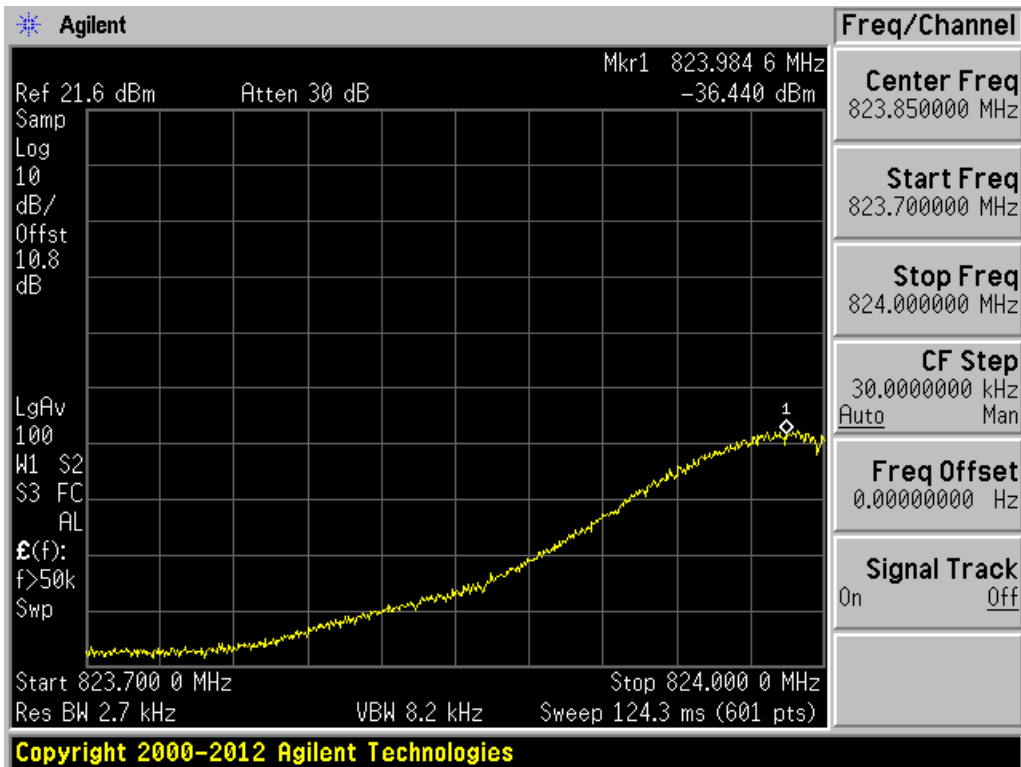


Figure 4

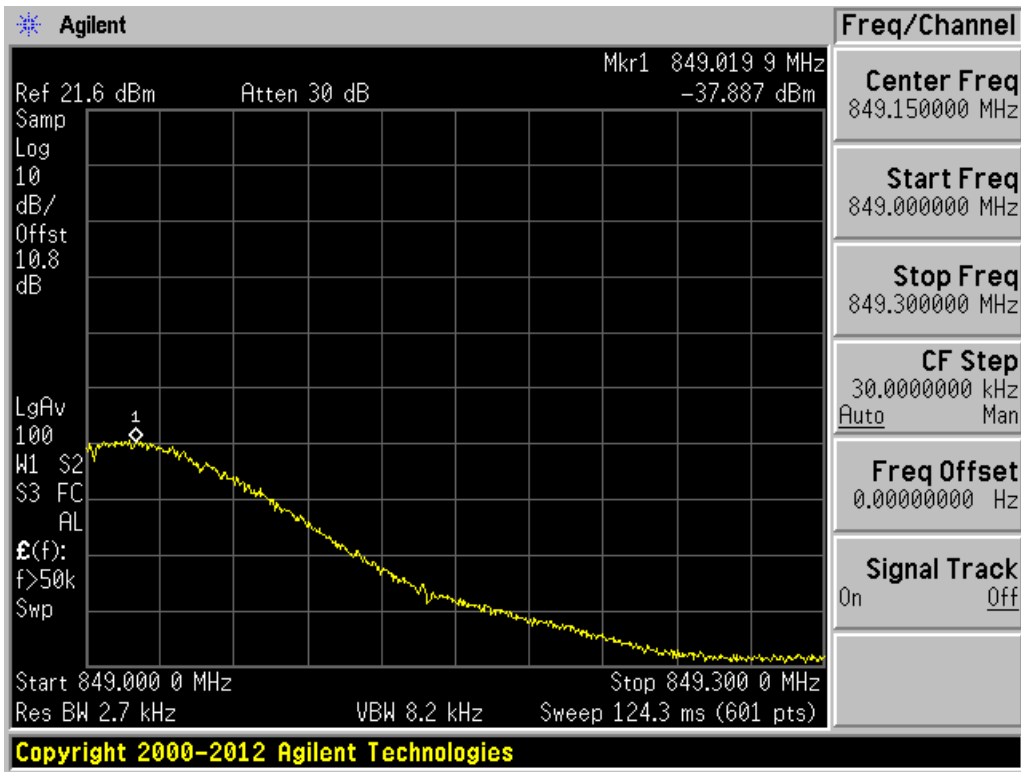
- A. Connect the EUT to the test equipment as shown in figure 4. Begin with the uplink output connected to the spectrum analyzer.
- B. Configure the signal generator for the appropriate operation for all uplink and downlink bands:
 - GSM: 0.2 MHz from upper and lower band edge
 - LTE: 2.5 MHz from upper and lower band edge
 - CDMA: 1.25 MHz from upper and lower band edge, except for cellular as follows (only the upper and lower frequencies need to be tested):
 - 824.88 MHz
 - 848.10 MHz
 - 869.88 MHz
 - 893.10 MHz
- C. Set the signal generator power to a level just below (within 0.5 dB of) the AGC limit without triggering the AGC. Configure signal generator with appropriate modulations.
- D. Set RBW = measurement bandwidth specified in the applicable rule section for the supported frequency band.
- E. Set VBW = 3 X RBW.
- F. Select the RMS (power averaging) detector.
- G. Sweep time = auto-couple.
- H. Set the analyzer start frequency to the upper band/block edge frequency and the stop frequency to the upper band/block edge frequency plus 300 kHz (when operational frequency is < 1 GHz) or 3 MHz (when operational frequency is ≥ 1 GHz).
- I. Trace average at least 100 traces in power averaging (i.e., RMS) mode.
- J. Use peak marker function to find the maximum power level.

- K. Capture the Spectrum Analyzer trace of the power level for inclusion in the test report.
- L. Ensure that the EUT maintains compliance with the OOB limits.
- M. Reset the analyzer start frequency to the lower band/block edge frequency minus 300 kHz (when operational frequency is < 1 GHz) or 3 MHz (when operational frequency is ≥ 1 GHz), and the stop frequency to the lower band/block edge frequency and repeat steps J to L.
- N. Repeat steps A through M for each uplink and downlink operational band.

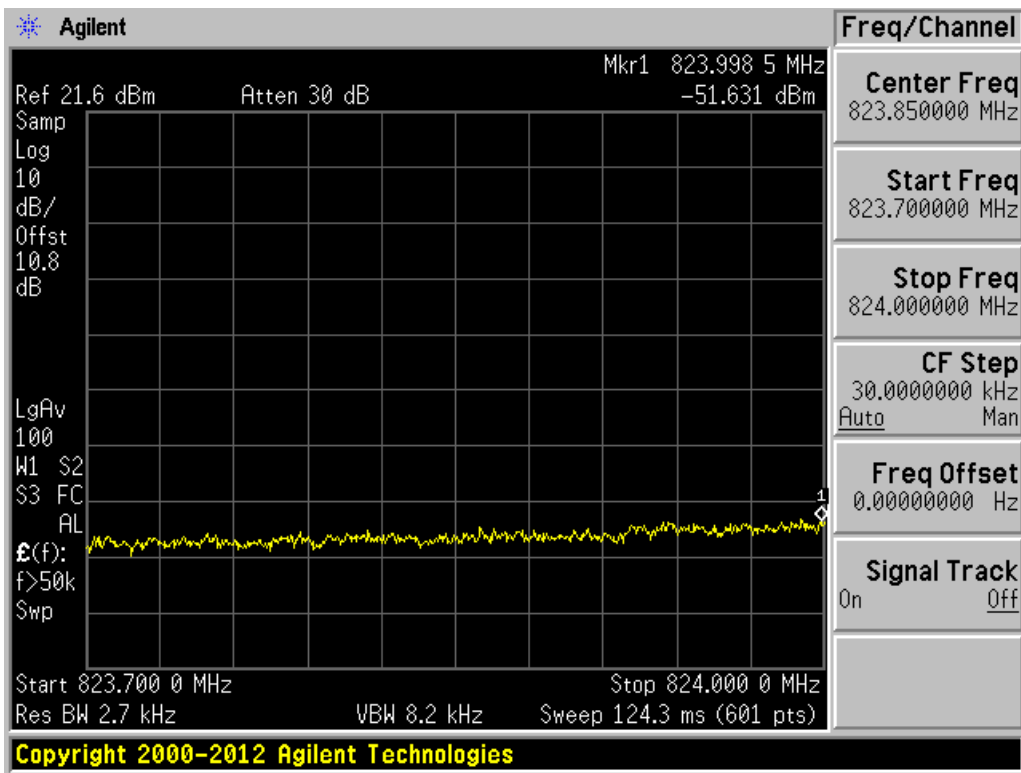
3.5.2 Out of band emissions test results



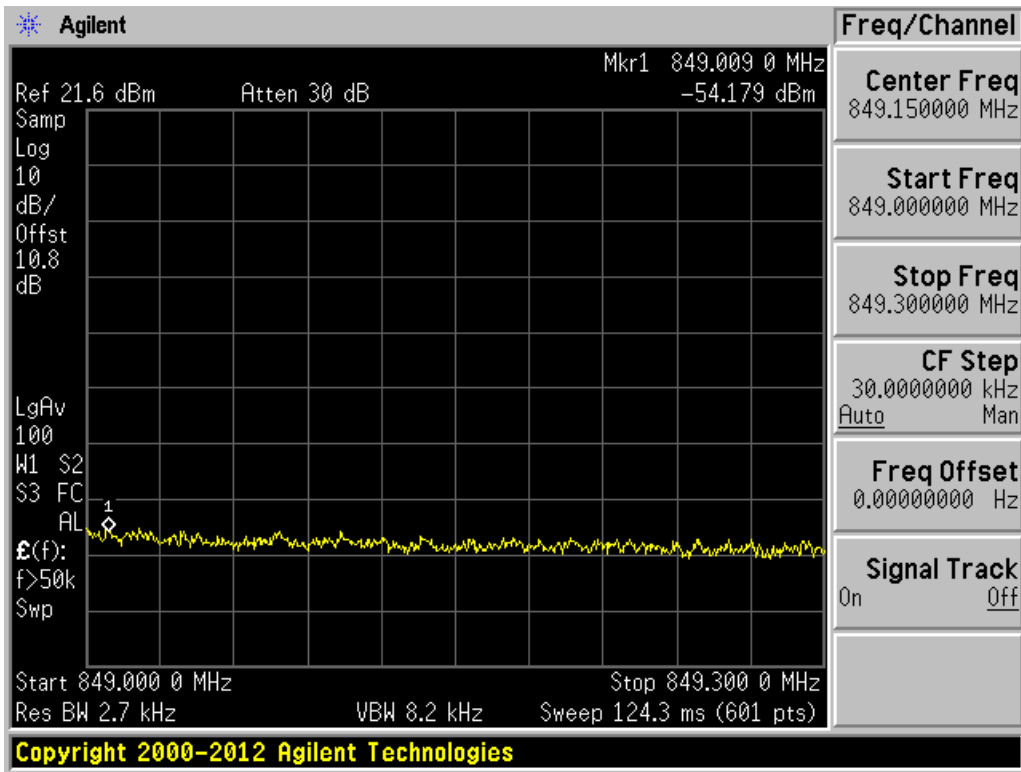
Uplink GSM signal 824.2 MHz



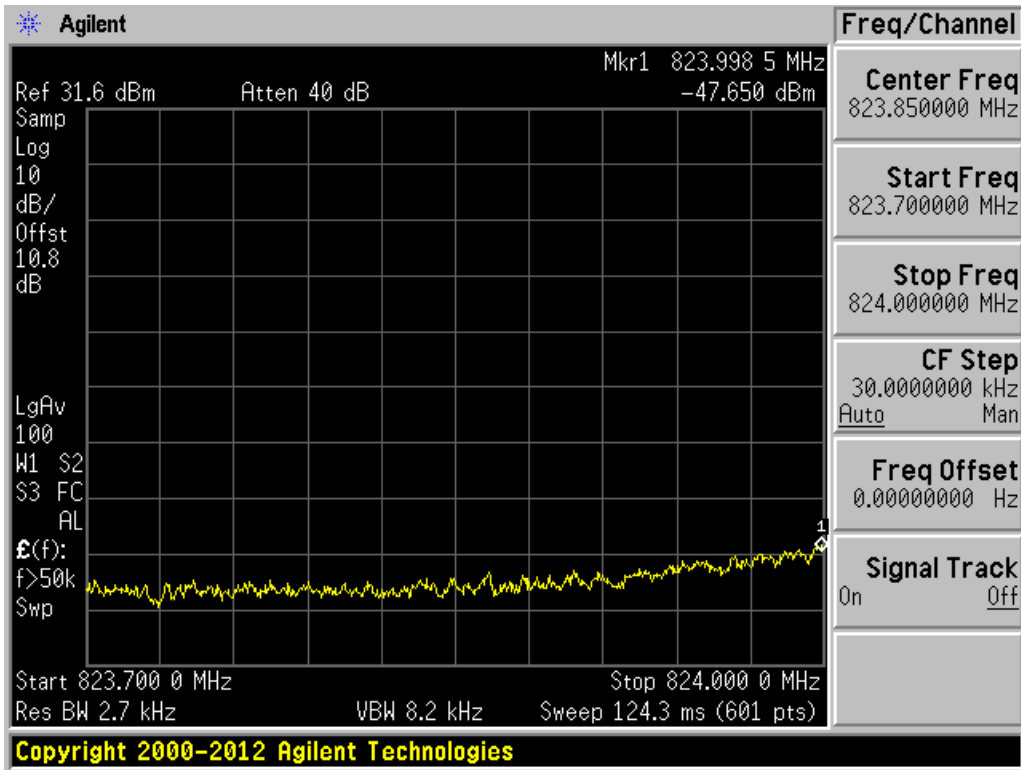
Uplink GSM signal 848.8 MHz



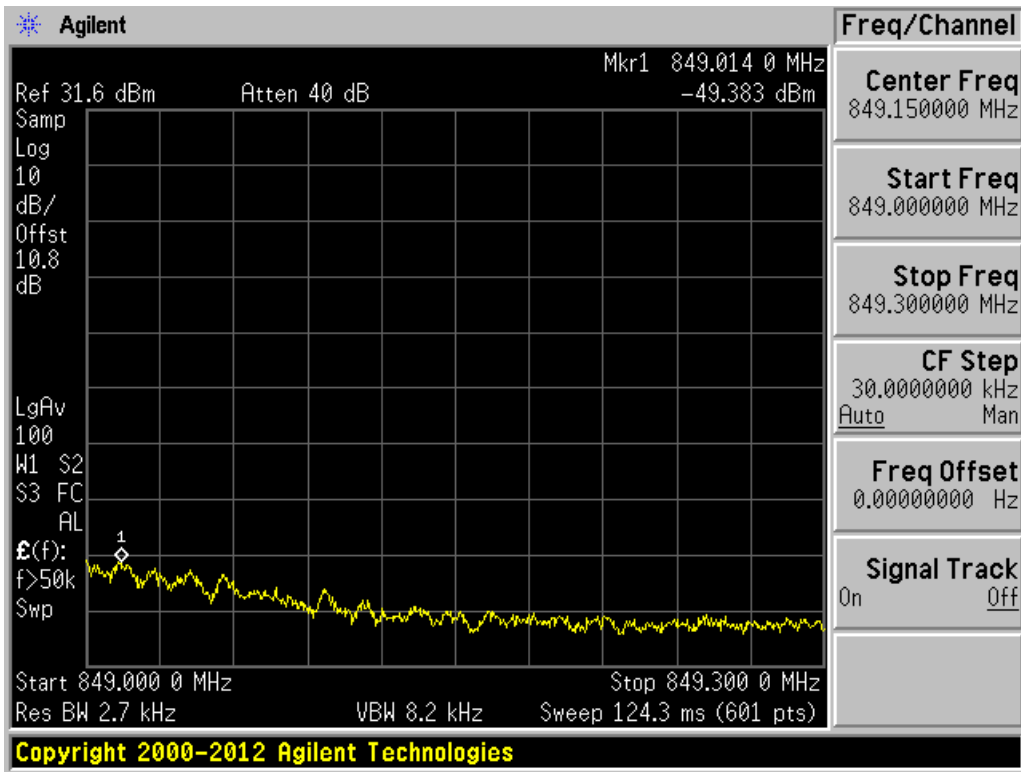
Uplink CDMA signal 824.88 MHz



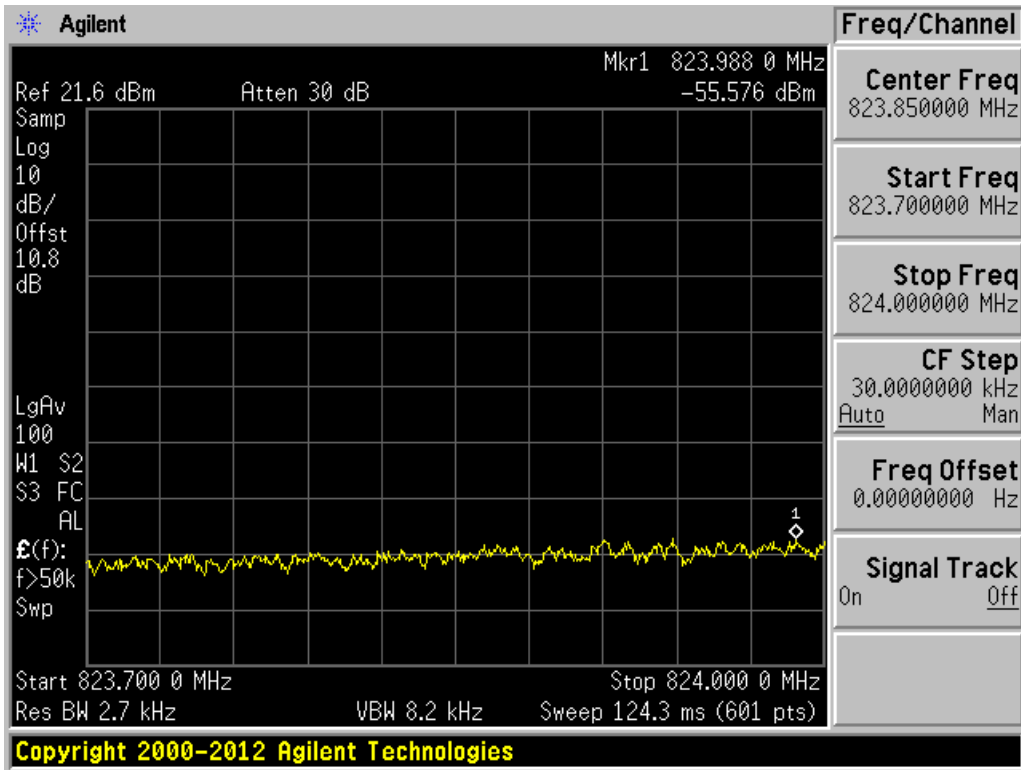
Uplink CDMA signal 848.10 MHz



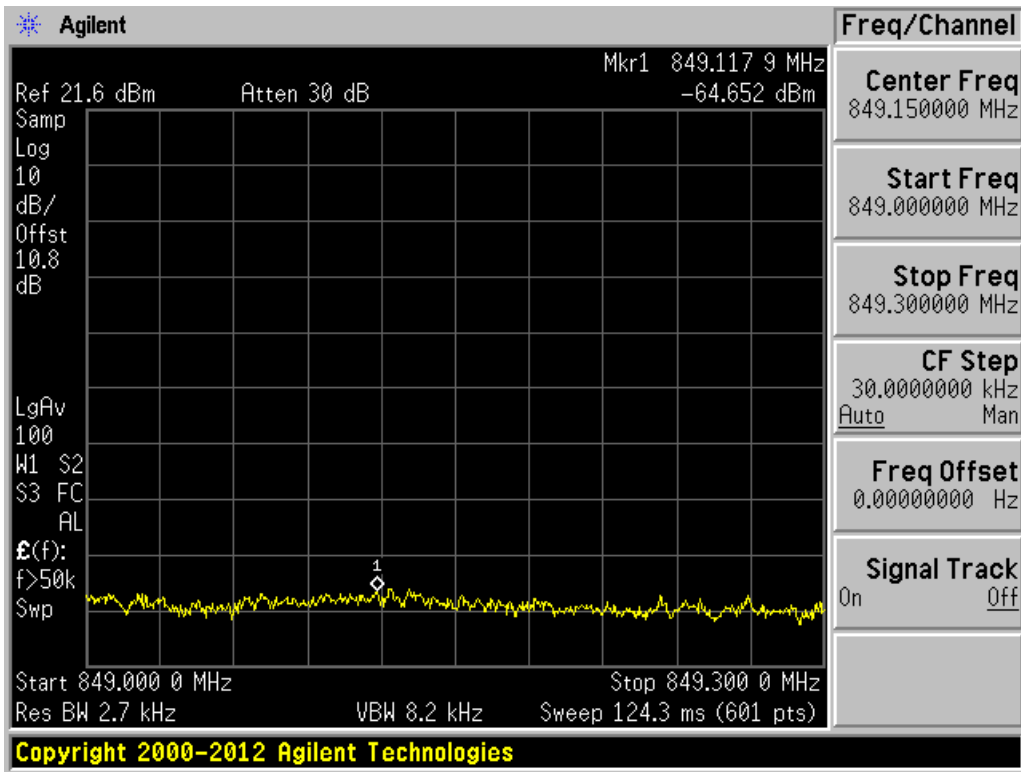
Uplink LTE Signal 826.5 MHz



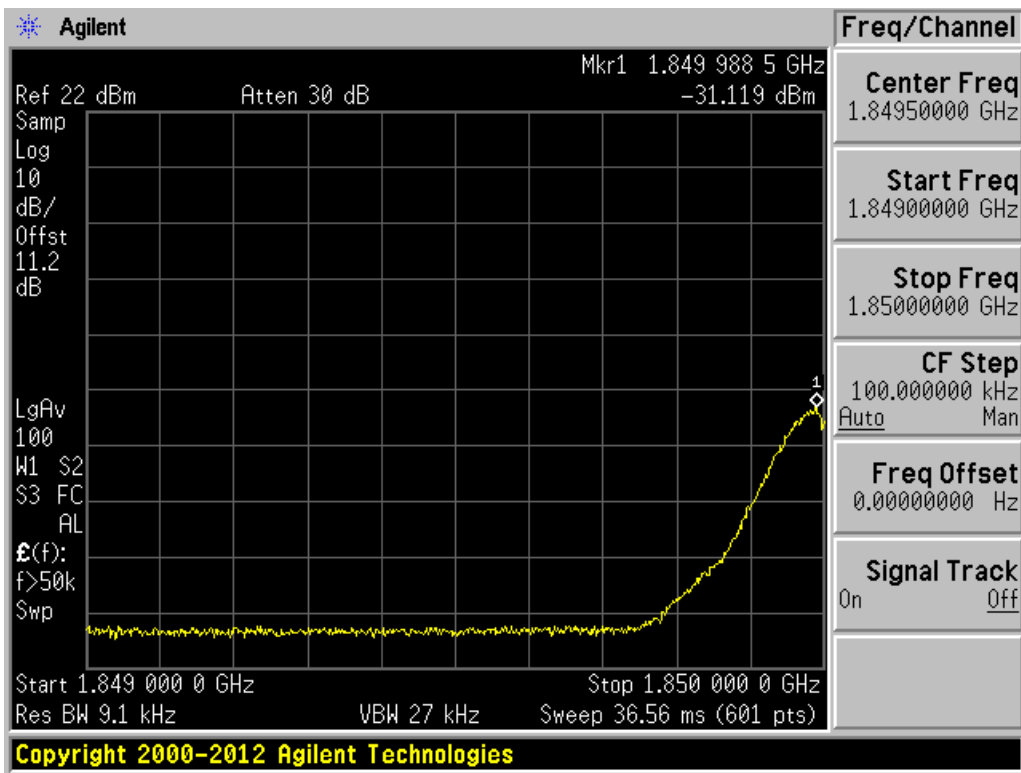
Uplink LTE Signal 846.5 MHz



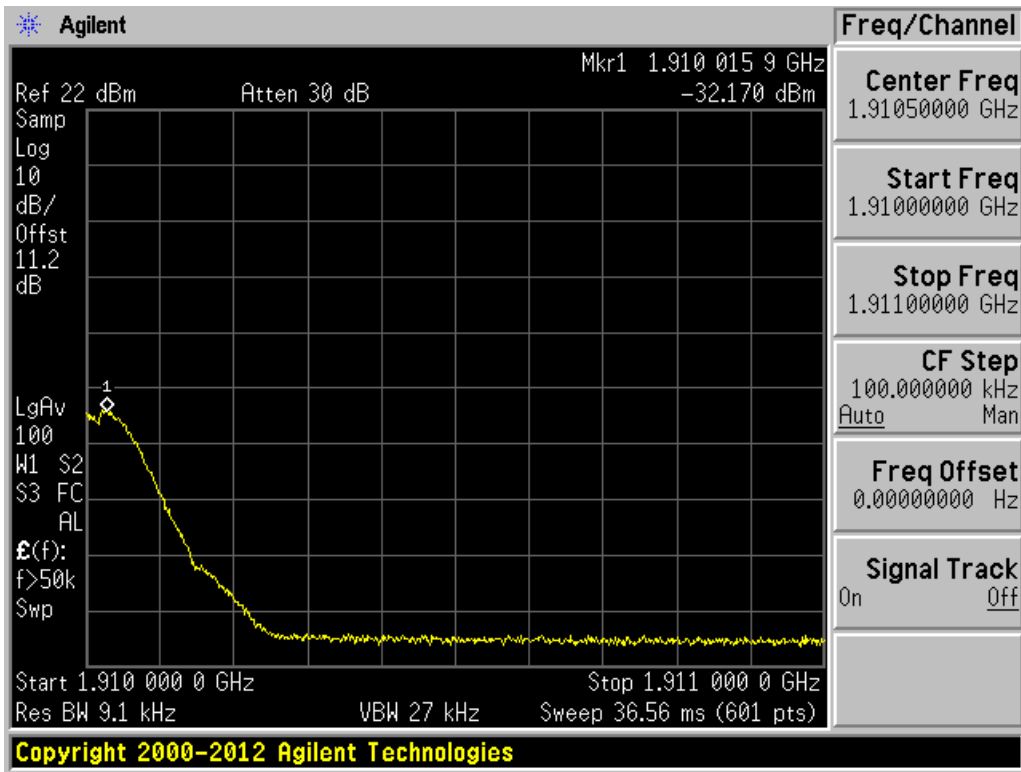
Uplink WCDMA Signal 826.5 MHz



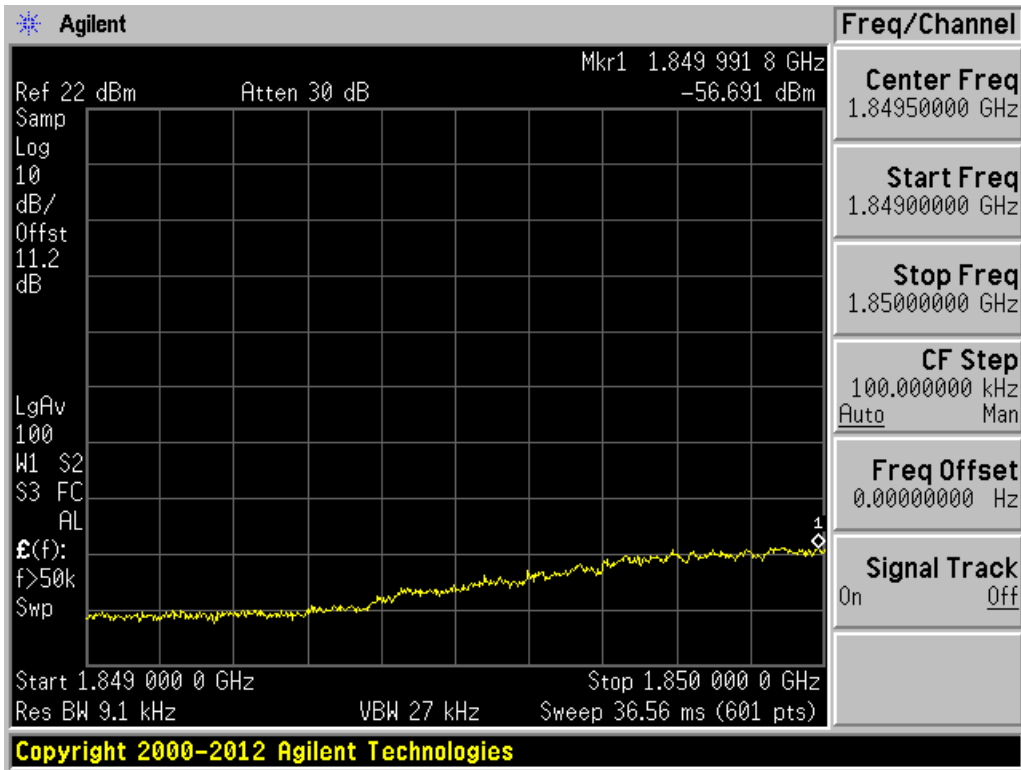
Uplink WCDMA Signal 846.5 MHz



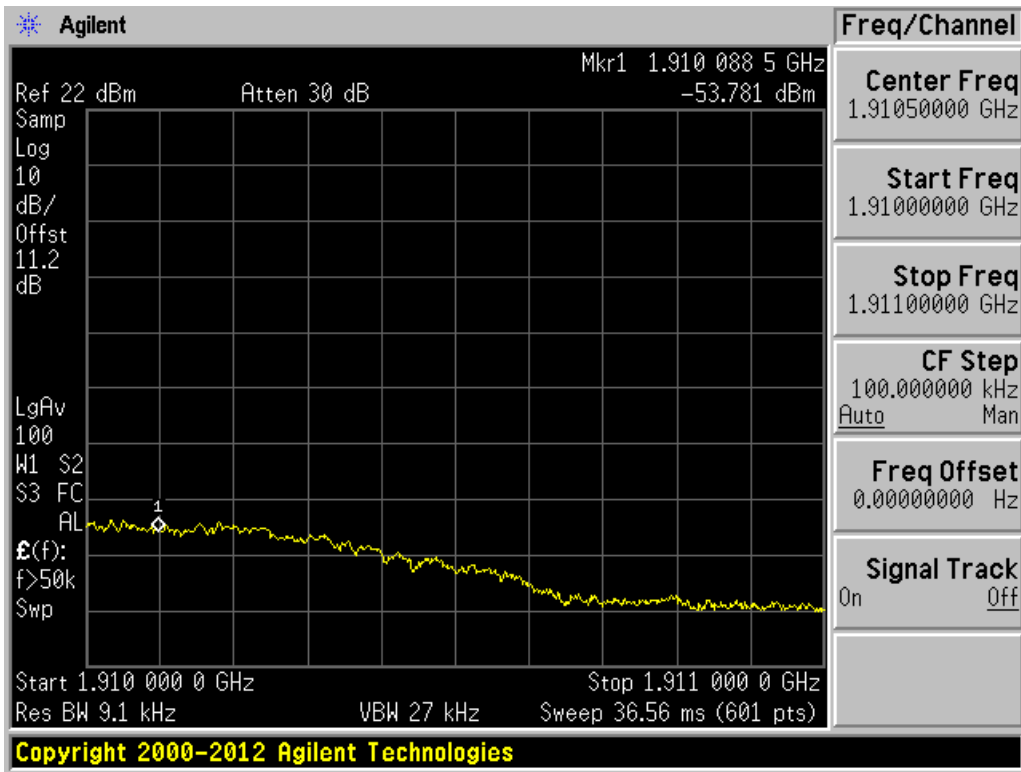
Uplink GSM signal 1850.2 MHz



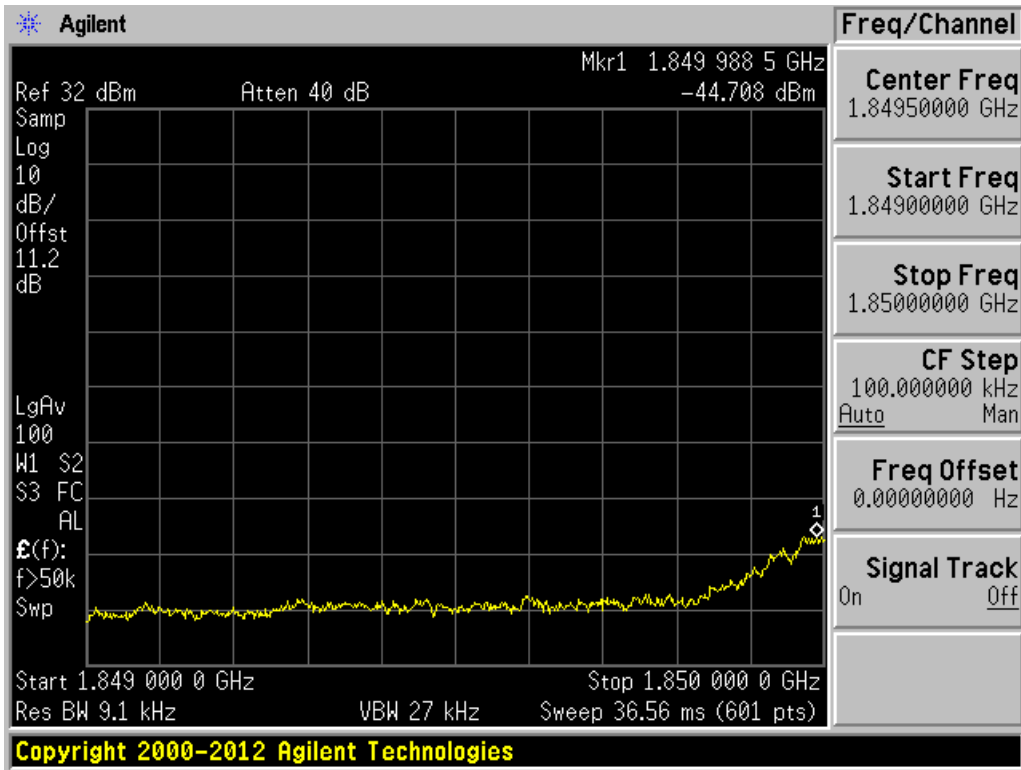
Uplink GSM signal 1909.8 MHz



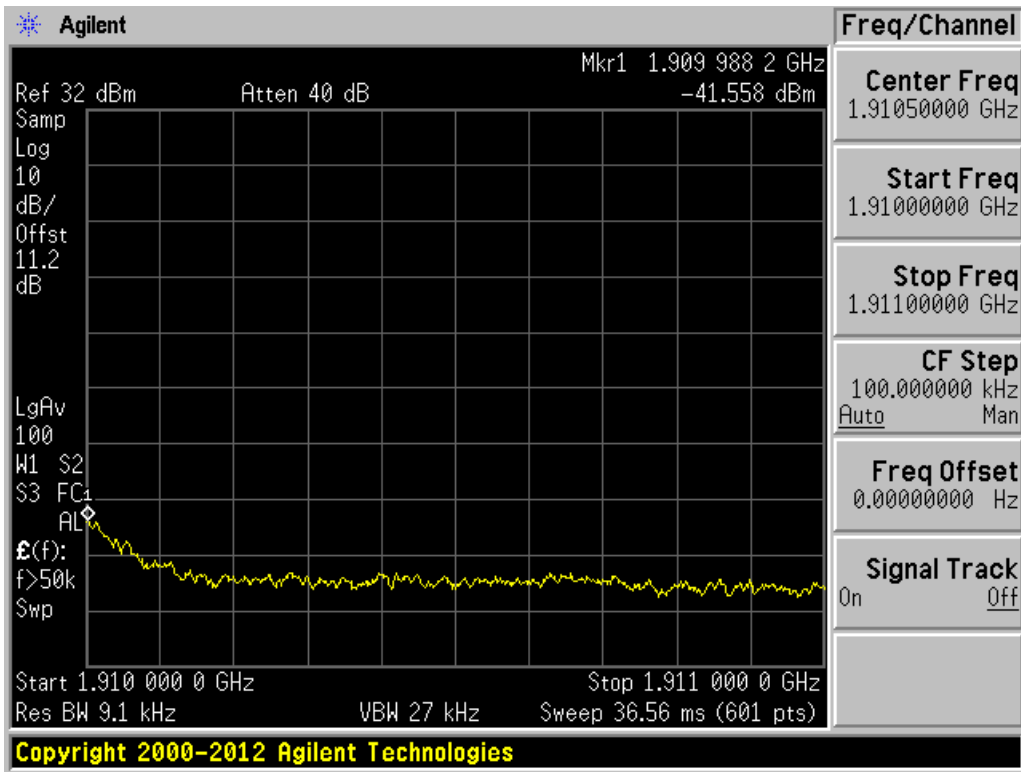
Uplink CDMA signal 1851.25 MHz



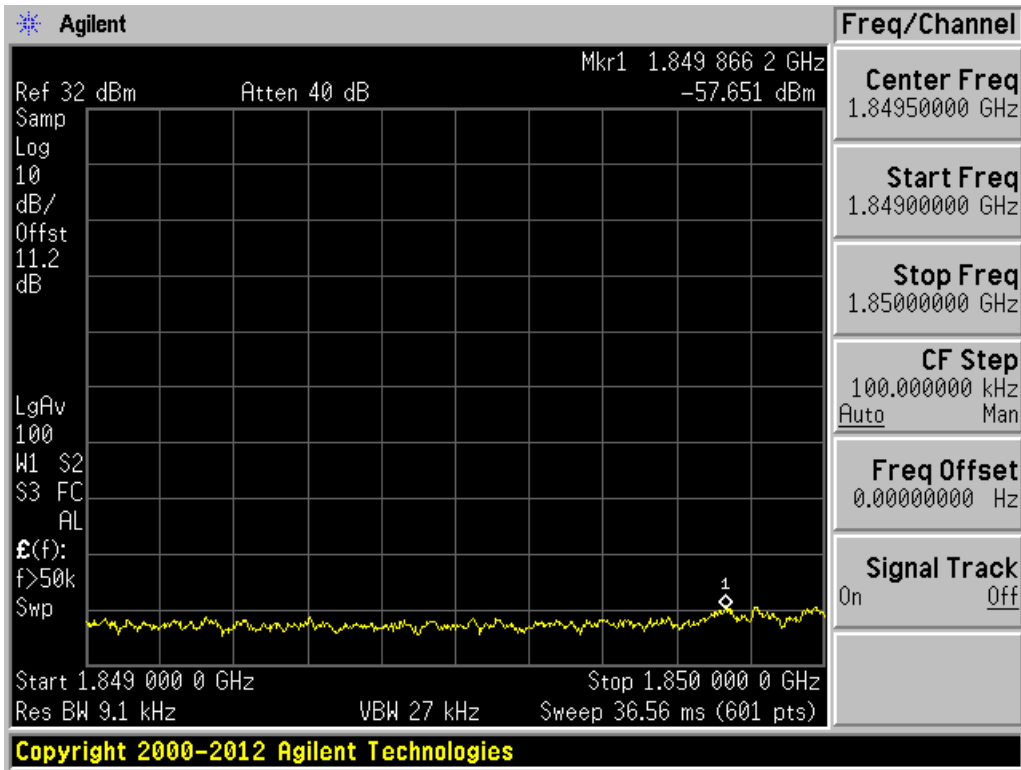
Uplink CDMA signal 1908.75 MHz



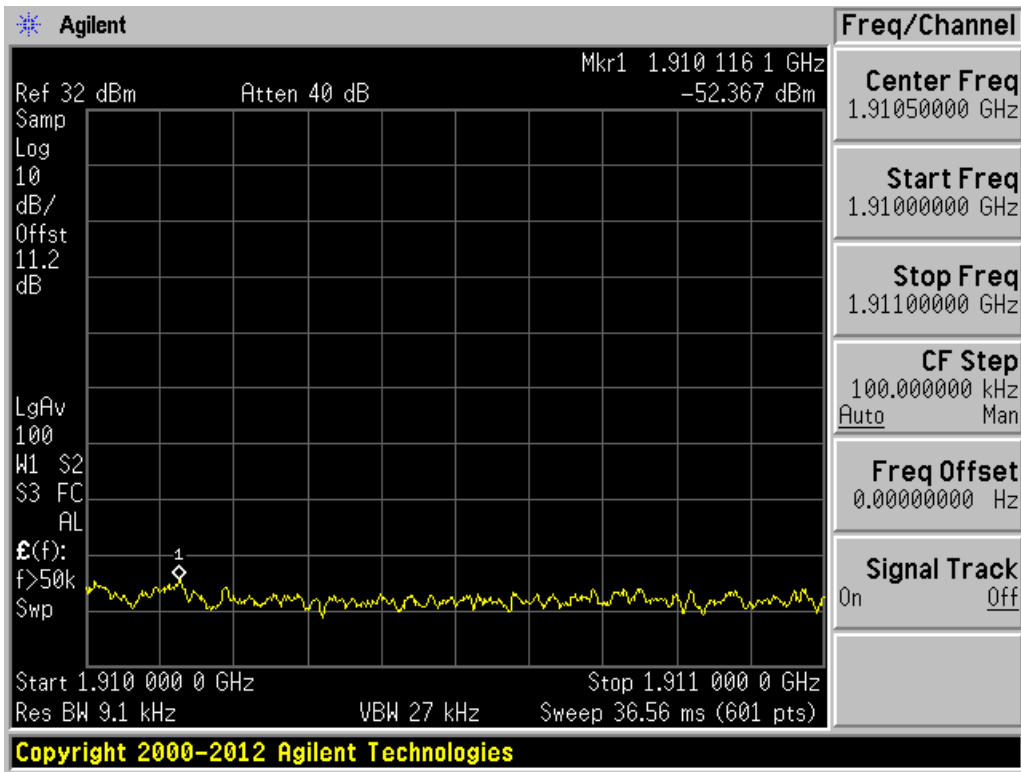
Uplink LTE Signal 1852.5 MHz



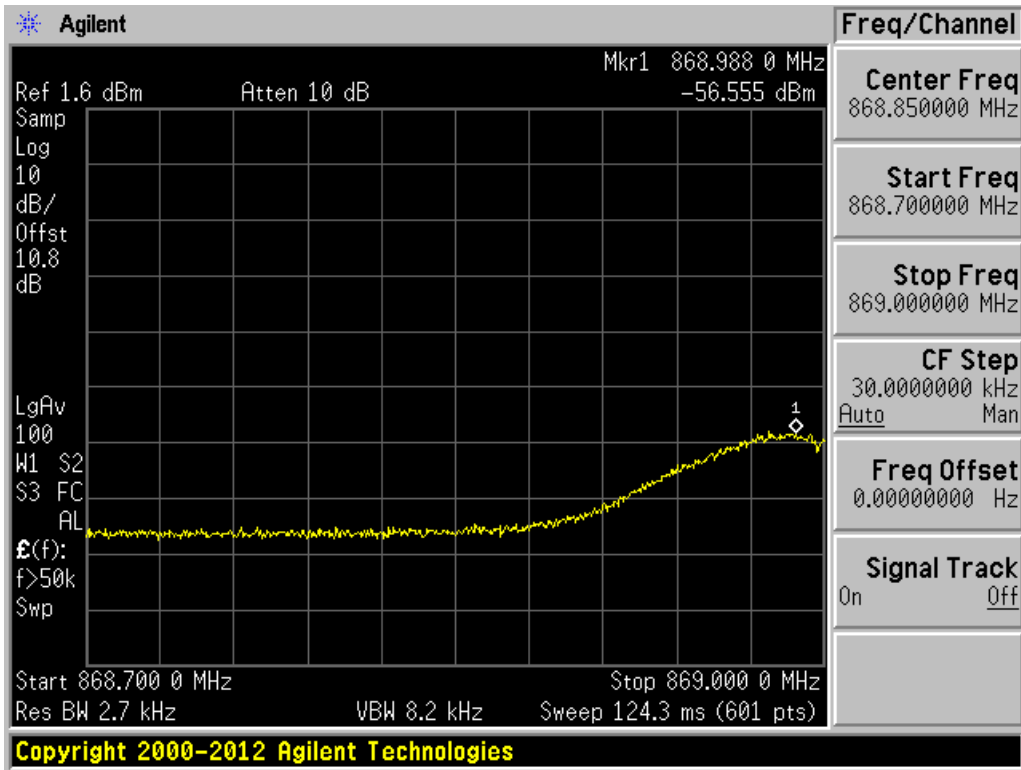
Uplink LTE Signal 1907.5 MHz



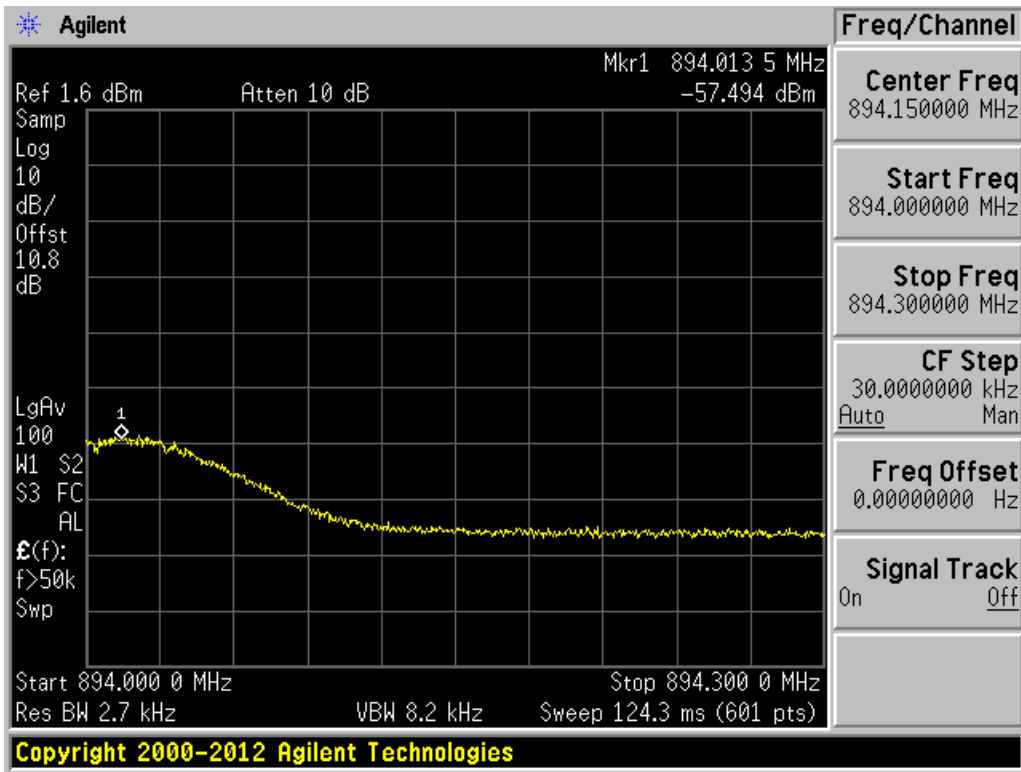
Uplink WCDMA Signal 1852.5 MHz



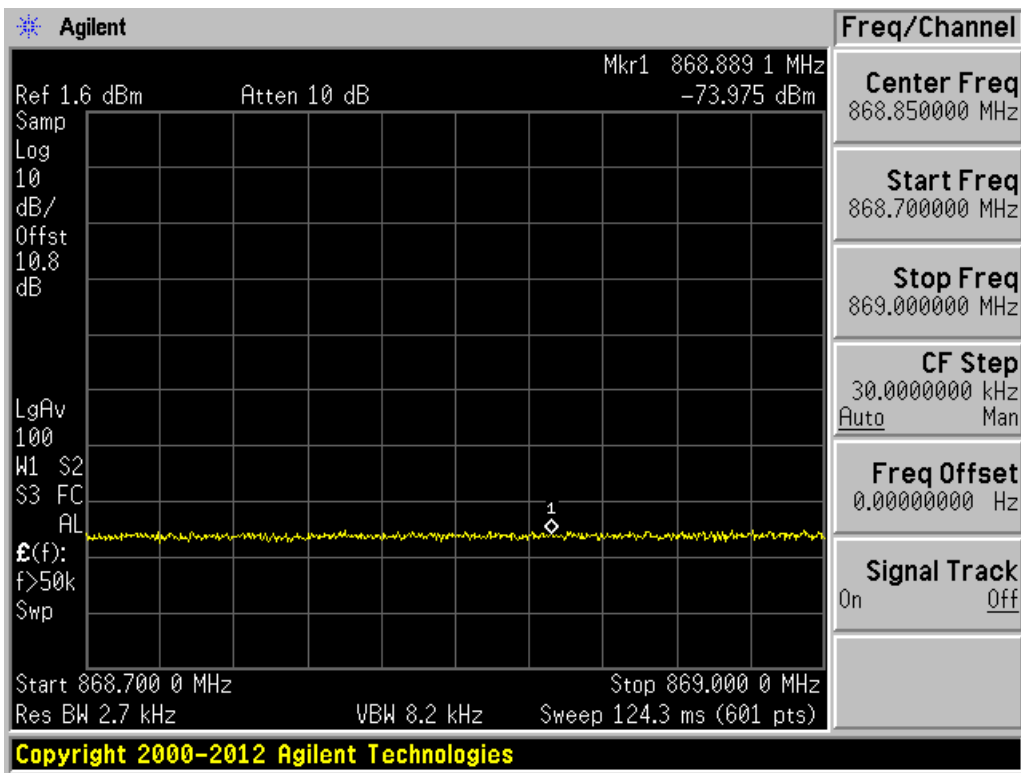
Uplink WCDMA Signal 1907.5 MHz



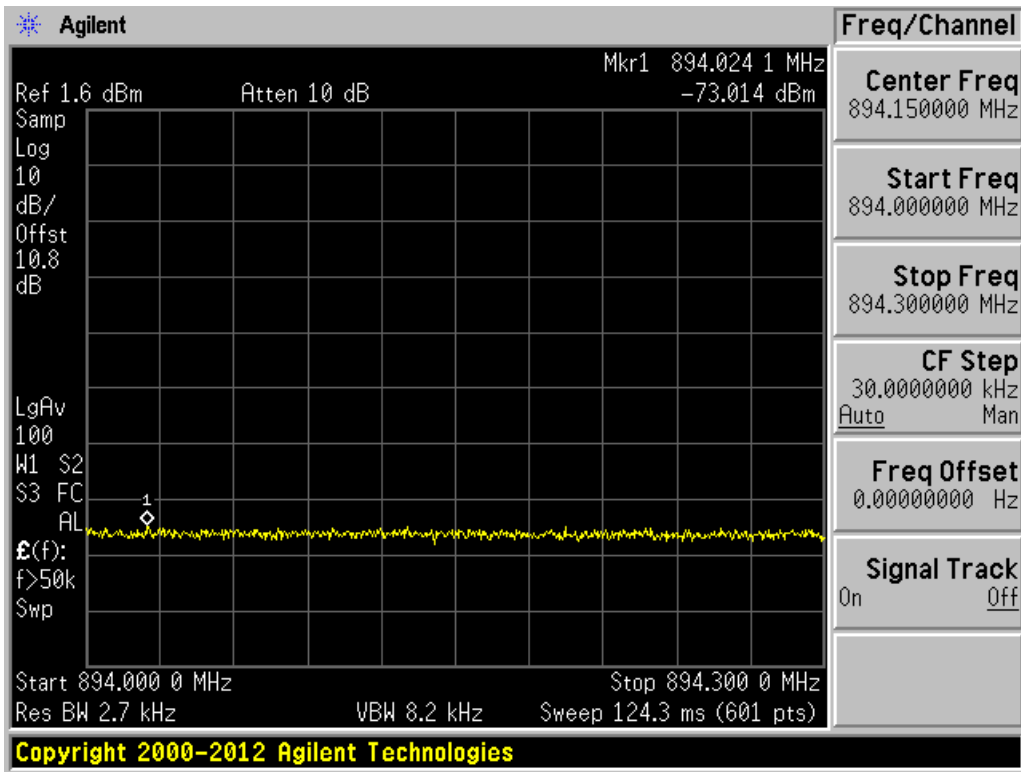
Downlink GSM signal 869.2 MHz



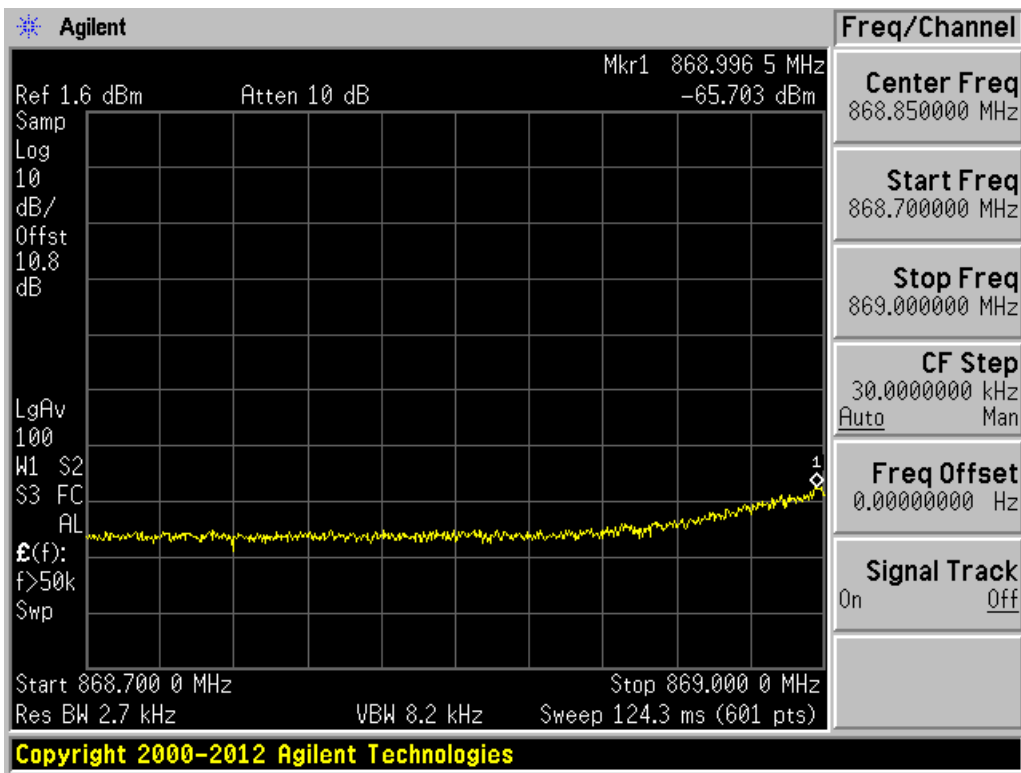
Downlink GSM signal 893.8 MHz



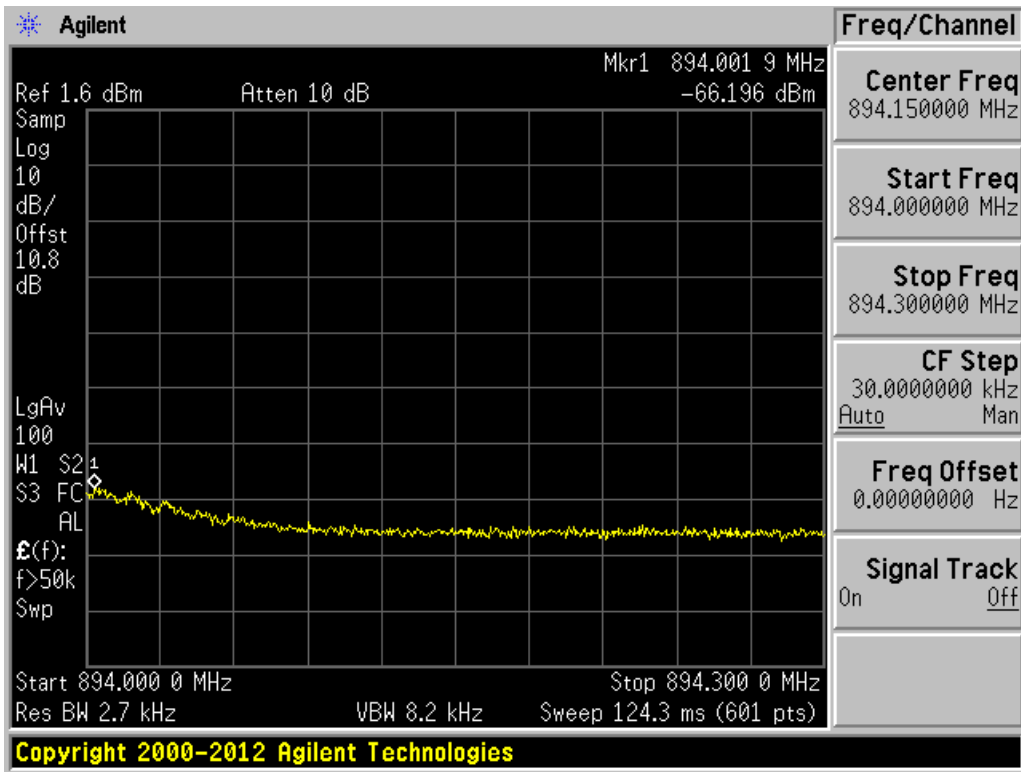
Downlink CDMA signal 869.88 MHz



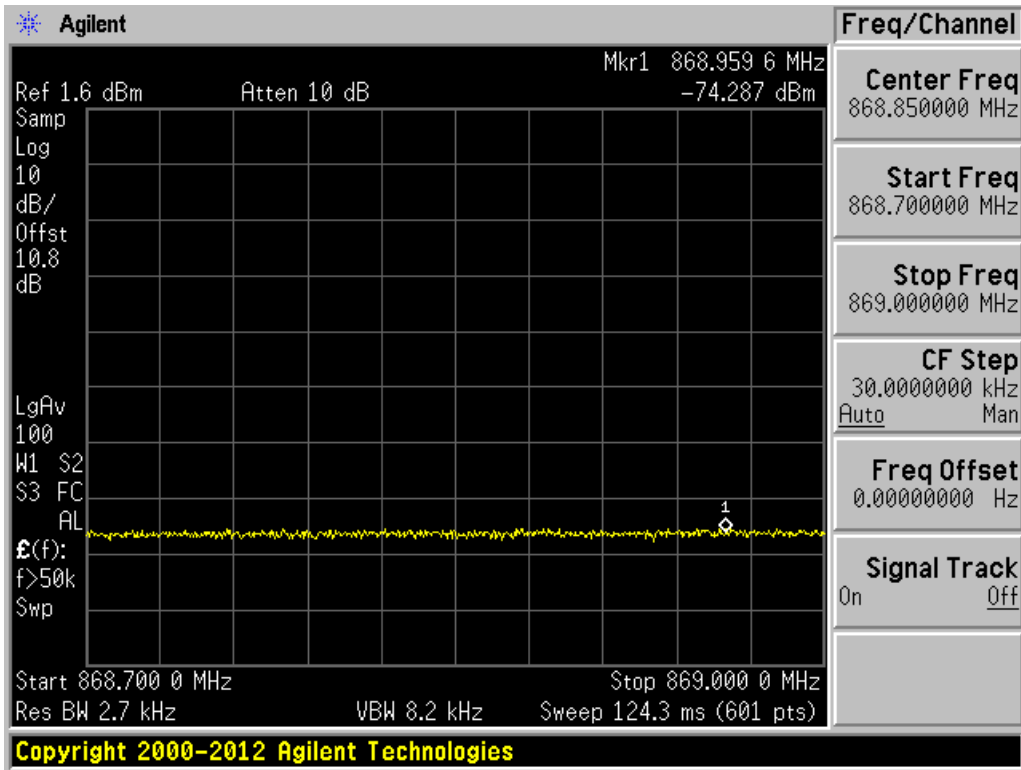
Downlink CDMA signal 893.10 MHz



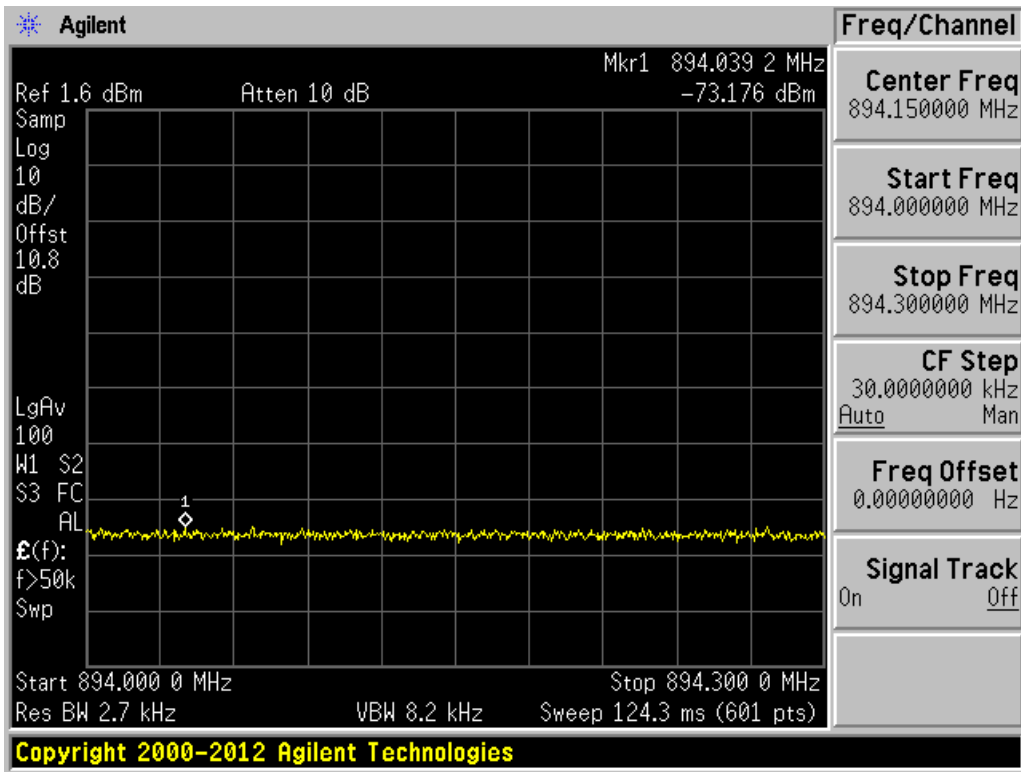
Downlink LTE Signal 871.5 MHz



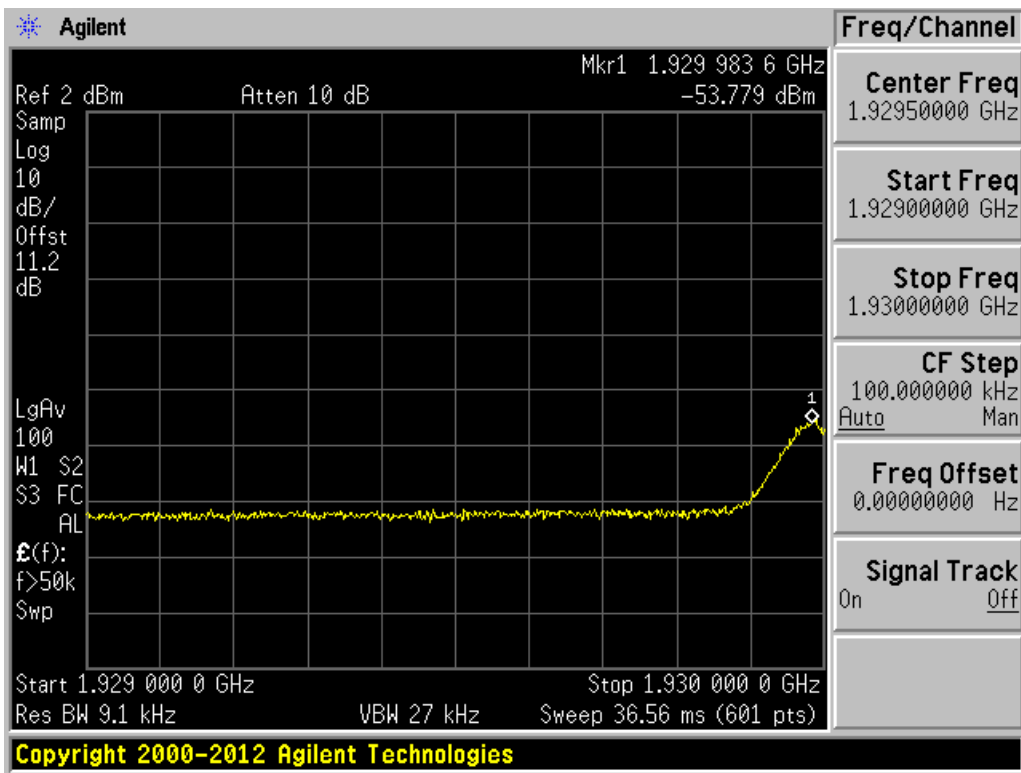
Downlink LTE Signal 891.5 MHz



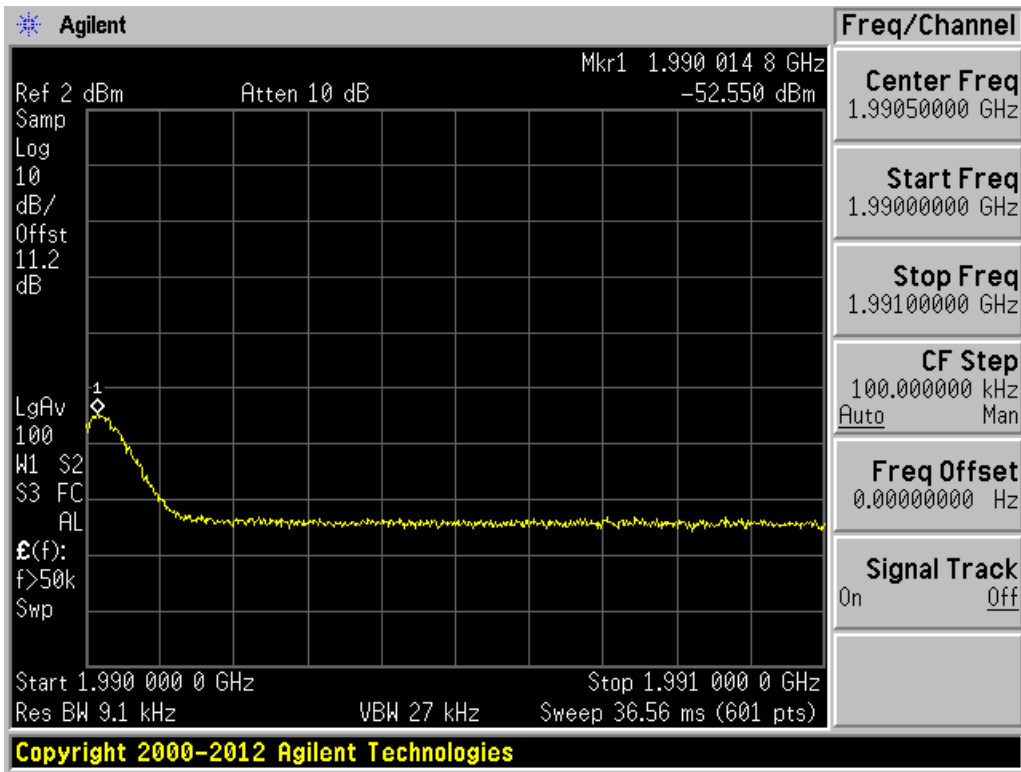
Downlink WCDMA Signal 871.5 MHz



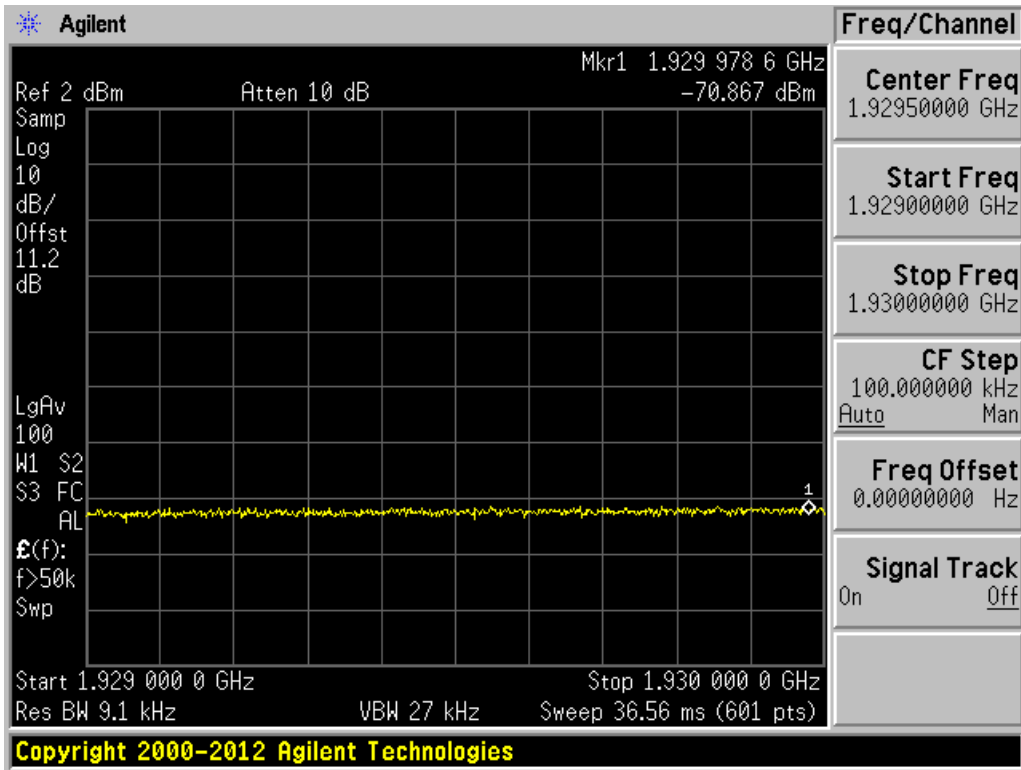
Downlink WCDMA Signal 891.5 MHz



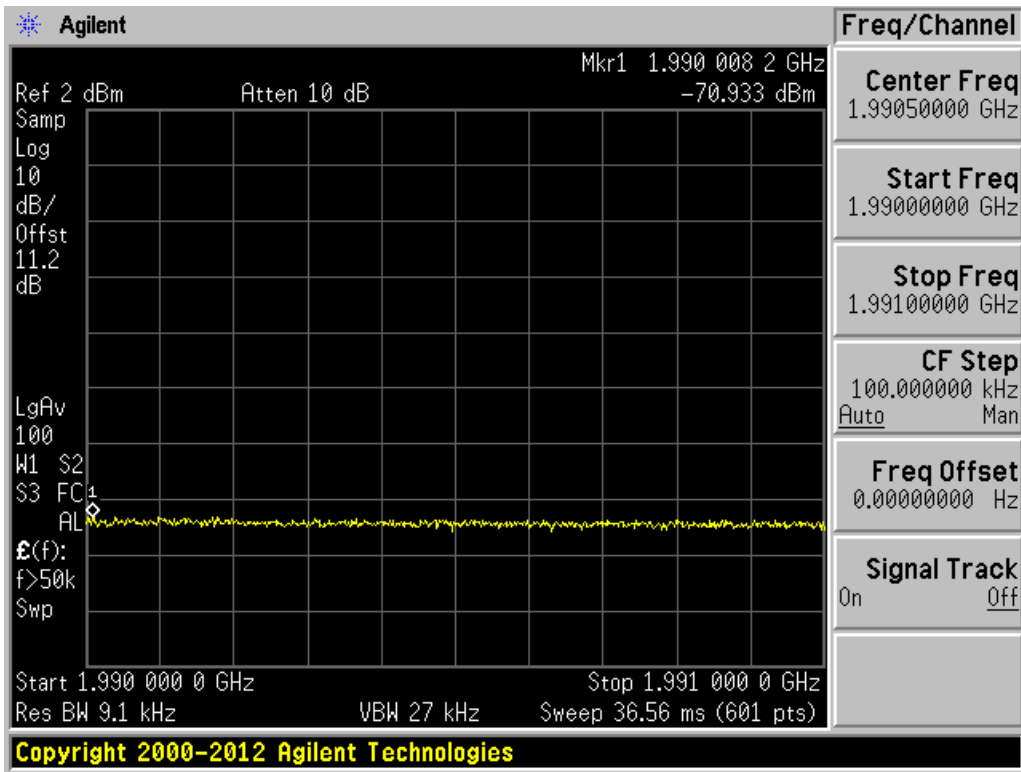
Downlink GSM signal 1930.2 MHz



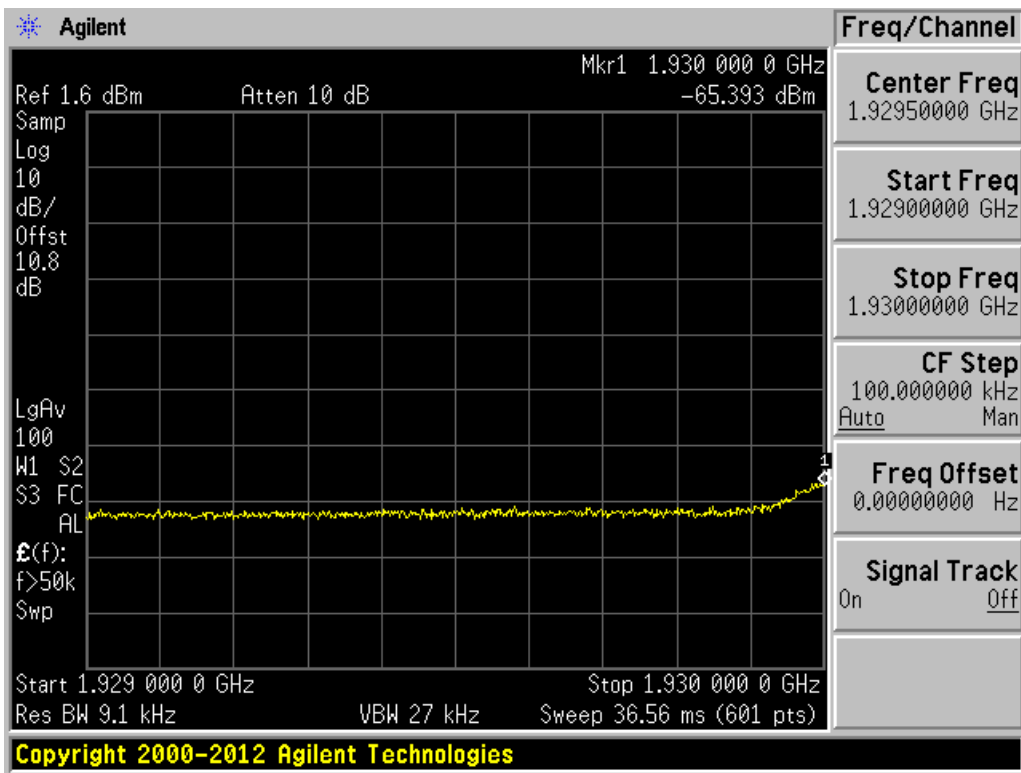
Downlink GSM signal 1989.8 MHz



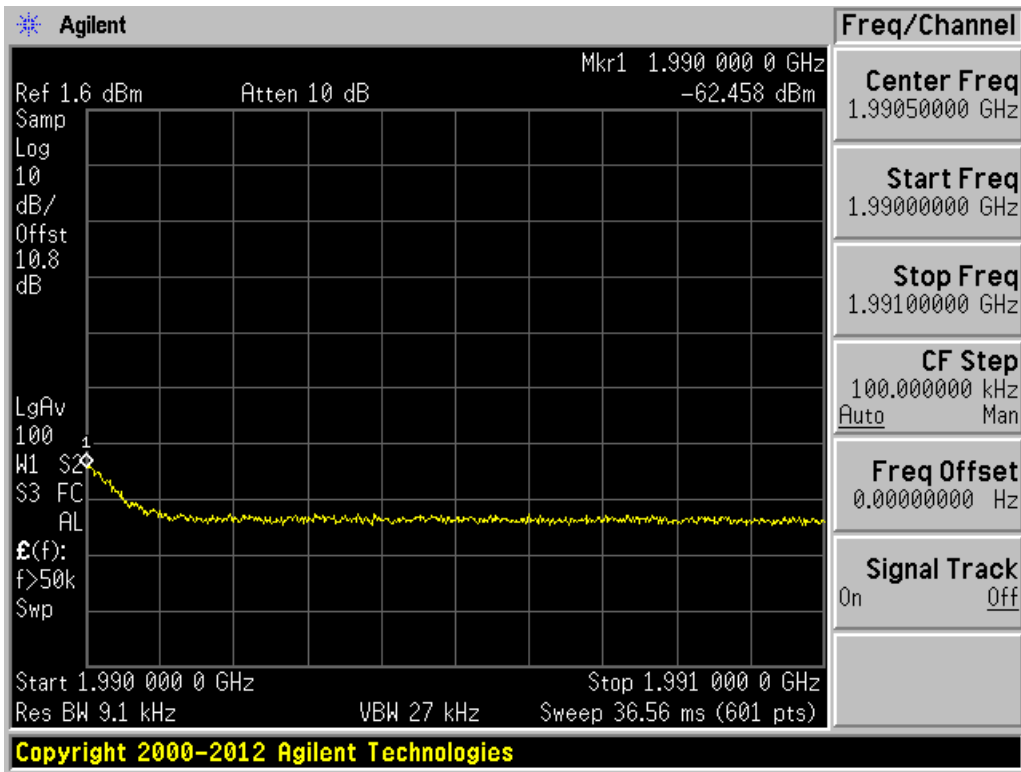
Downlink CDMA signal 1931.25 MHz



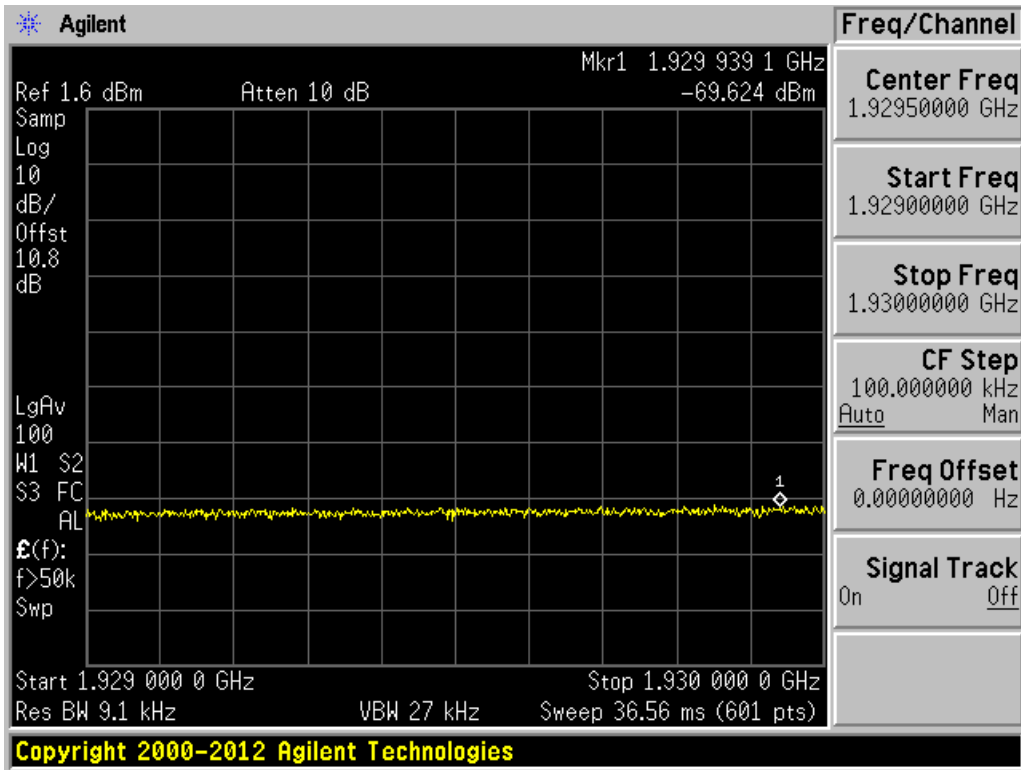
Downlink CDMA signal 1988.75 MHz



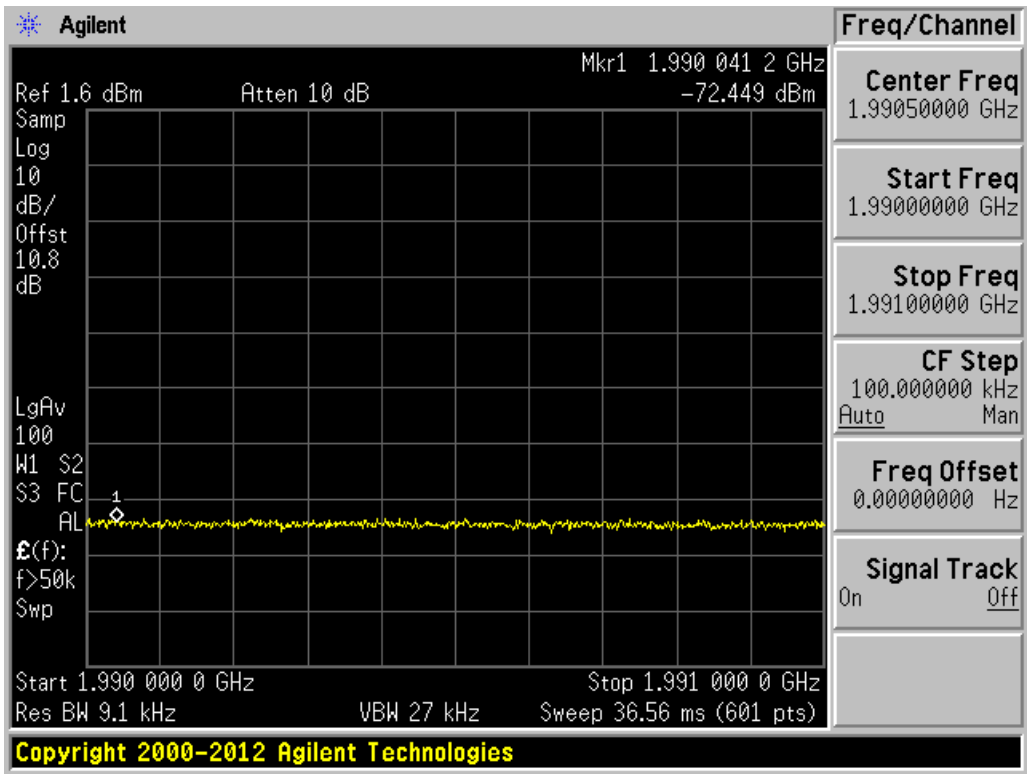
Downlink LTE Signal 1932.5 MHz



Downlink LTE Signal 1987.5 MHz



Downlink WCDMA Signal 1932.5 MHz



Downlink WCDMA Signal 1987.5 MHz

3.6 Conducted Spurious Emissions Test

(Reference: KDB #935210 D03, § 7.6)

Rule paragraph(s):

§ 2.1051 Spurious emissions at antenna terminals.

3.6.1 Conducted spurious emissions test procedure



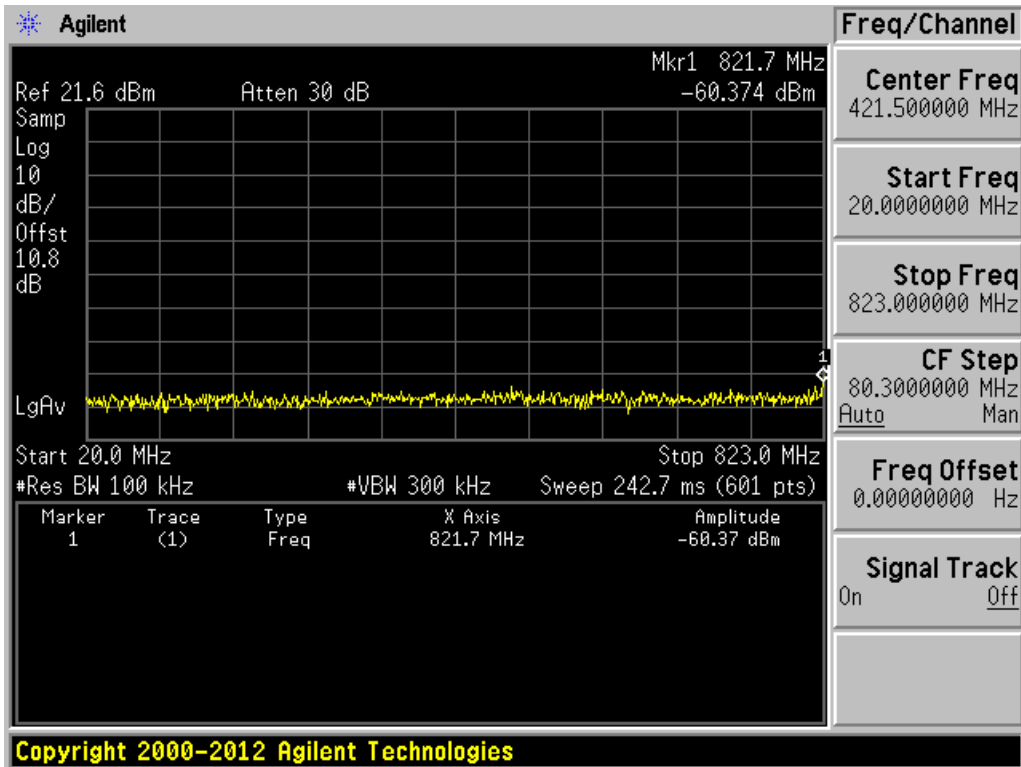
Figure 5

- A. Connect the EUT to the test equipment as shown in Figure 5. Begin with the uplink output connected to the spectrum analyzer.
- B. Configure the signal generator for AWGN with an emissions bandwidth of 4.1 MHz operation with a center frequency corresponding to the center of the operational band under test and with a bandwidth representative of the bandwidth of the uplink or downlink signal.
- C. Set the signal generator power to a level just below (within 0.5 dB of) the AGC limit without triggering the AGC.
- D. Turn on the signal generator RF output and measure the spurious emission power levels with an appropriate measurement instrument as follows:
- E. Set RBW 100 KHz
- F. Set VBW = 3 X RBW.
- G. Select the power averaging (RMS) detector.
- H. Sweep time = auto-couple.
- I. Set the analyzer start frequency to the lowest radio frequency signal generated in the equipment, without going below 9 kHz, and the stop frequency to the lower band/block edge frequency minus 100 kHz or 1 MHz, as specified in the applicable rule part. Note that the number of measurement points in each sweep must be $\geq (2 \times \text{span}/\text{RBW})$ which may require that the measurement range defined by the start and stop frequencies above be subdivided, depending on the available number of measurement points provided by the spectrum analyzer trace average at least 10 traces in power averaging (i.e., RMS) mode.
- J. Use the peak marker function to identify the highest amplitude level over each measured frequency range. Record the frequency and amplitude and capture a plot for inclusion in the test report.
- K. Reset the analyzer start frequency to the upper band/block edge frequency plus 100 kHz or 1 MHz, as specified in the applicable rule part, and the analyzer stop frequency to 10 times the highest frequency of the fundamental emission. Note that the number of measurement points in each sweep must be $\geq (2 \times \text{span}/\text{RBW})$ which may require that the measurement range defined by the start and stop

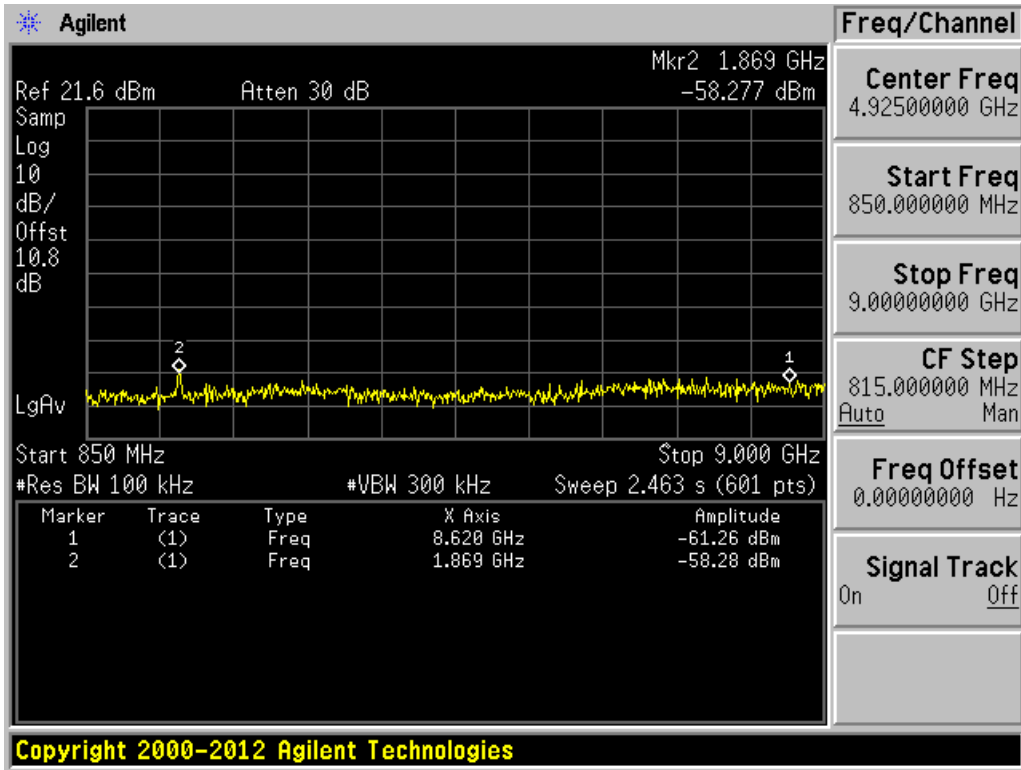
frequencies above be subdivided, depending on the available number of measurement points provided by the spectrum analyzer.

- L. Use the peak marker function to identify the highest amplitude level over each of the measured frequency ranges. Record the frequency and amplitude and capture a plot for inclusion in the test report.
- M. Repeat steps A through L for each supported frequency band of operation.

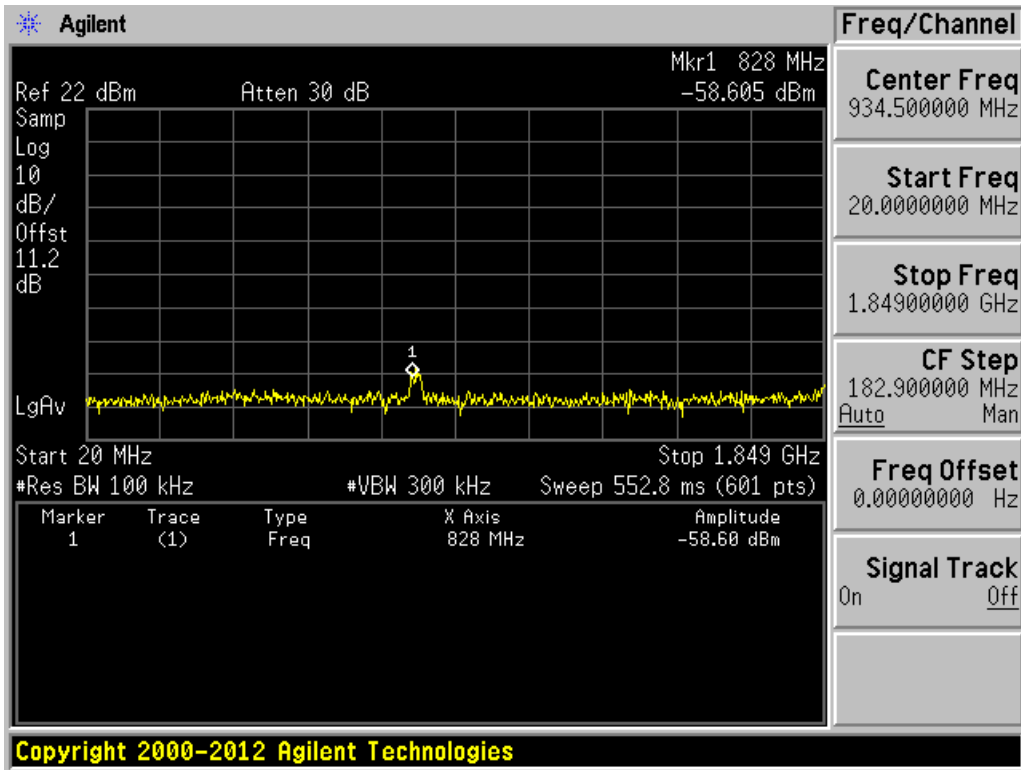
3.6.2 Conducted spurious emissions test results



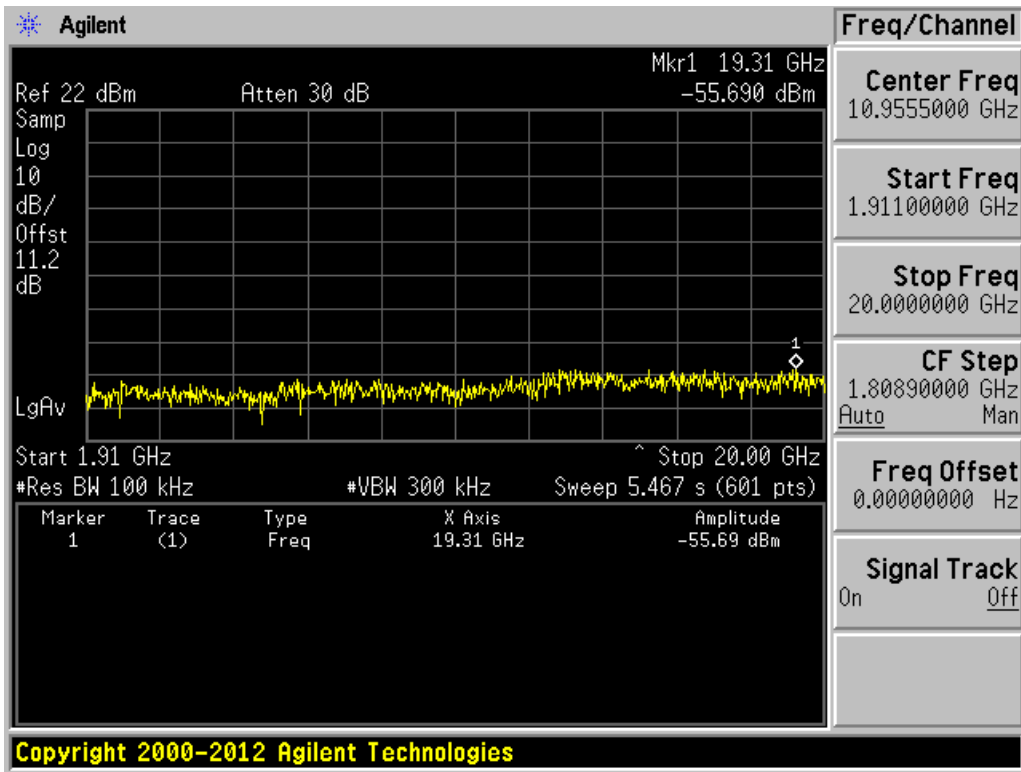
Uplink 800 MHz Conducted Spurious Emissions 20 MHz to 823 MHz



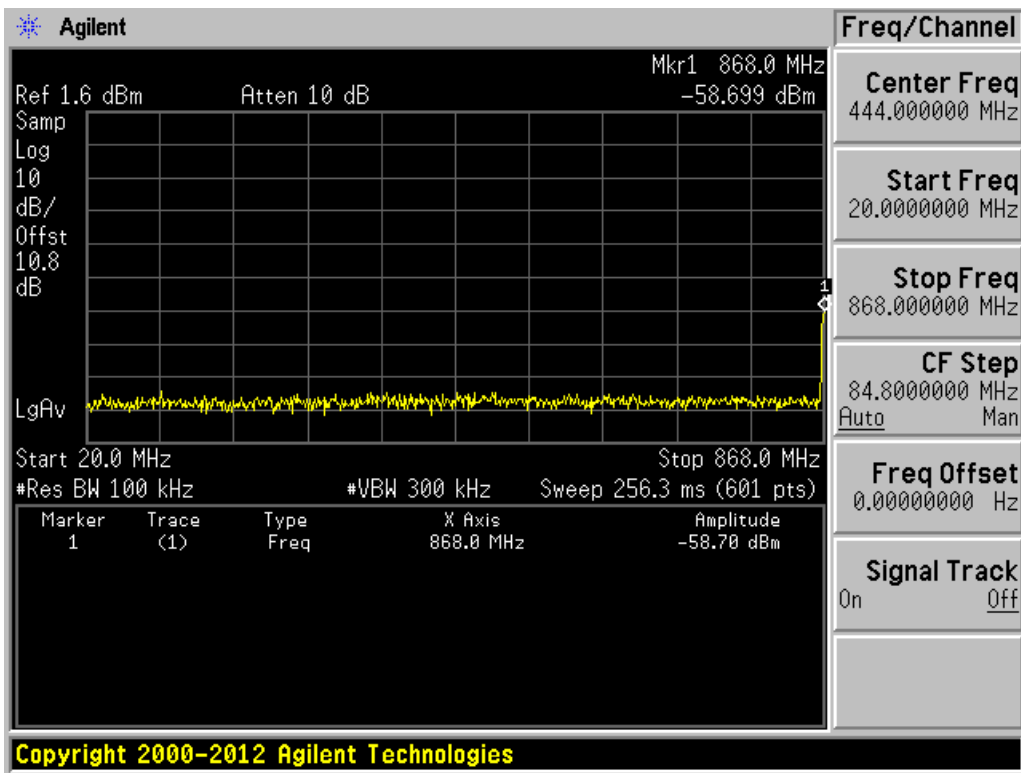
Uplink 800 MHz Conducted Spurious Emissions 850 MHz to 9 GHz



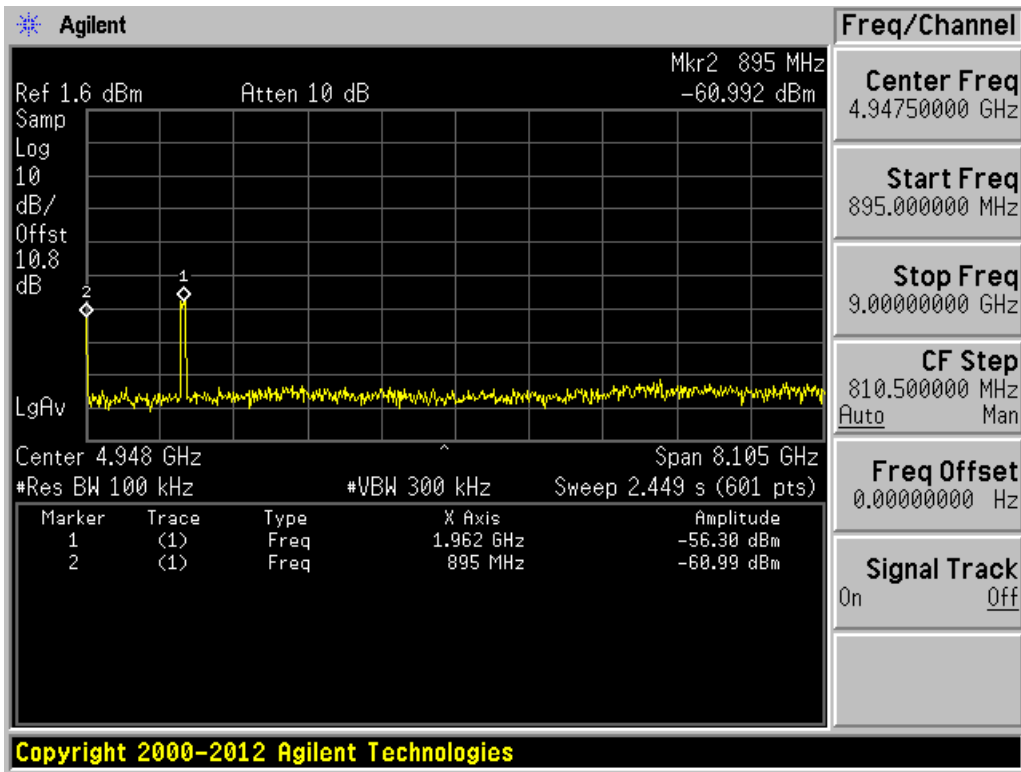
Uplink 1900 MHz Conducted Spurious Emissions 20 MHz to 1849 MHz



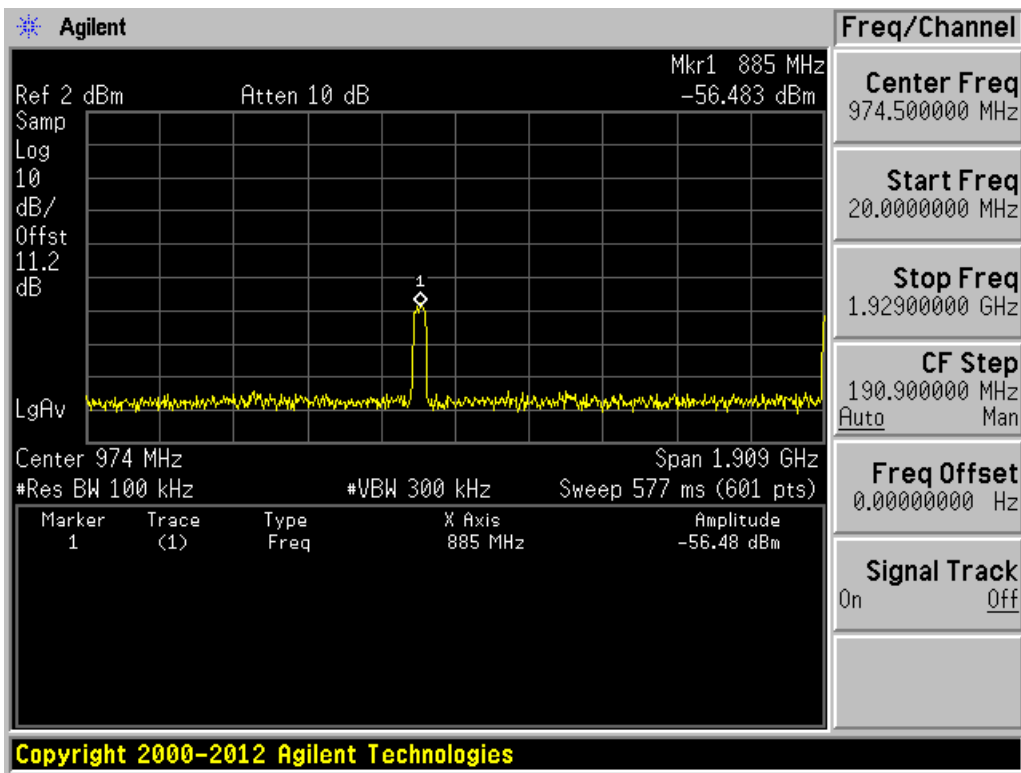
Uplink 1900 MHz Conducted Spurious Emissions 1911 MHz to 20 GHz



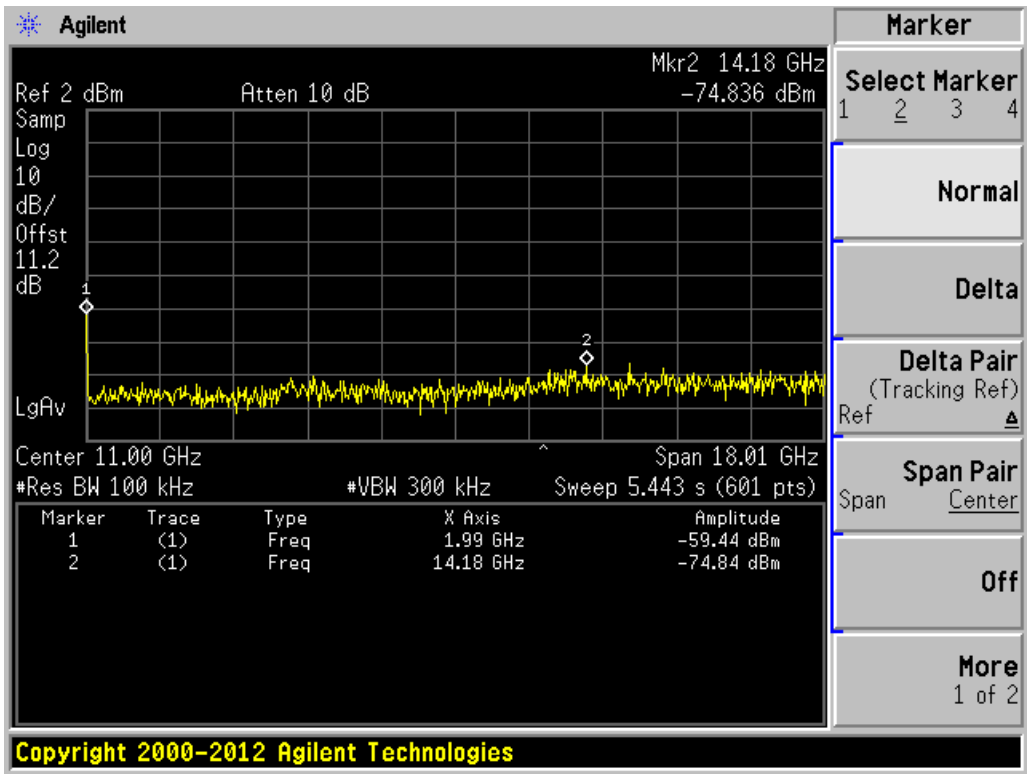
Downlink 800 MHz Conducted Spurious Emissions 20 MHz to 868 MHz



Downlink 800 MHz Conducted Spurious Emissions 895 MHz to 9 GHz



Downlink 1900 MHz Conducted Spurious Emissions 20 MHz to 1929 MHz



Downlink 1900 MHz Conducted Spurious Emissions 1991 MHz to 20 GHz

3.7 Noise Limits Test

(Reference: KDB #935210 D03, § 7.7)

Rule paragraph(s):

§ 20.21(e)(8)(i)(A) Noise Limits.

(1) *The transmitted noise power in dBm/MHz of consumer boosters at their uplink and downlink ports shall not exceed -103 dBm/MHz - RSSI. Where RSSI (received signal strength indication) is the downlink composite received signal power in dBm at the booster donor port for all base stations in the band of operation. RSSI is expressed in negative dB units relative to 1 mW.*

(2) *The transmitted maximum noise power in dBm/MHz of consumer boosters at their uplink and downlink ports shall not exceed the following limits:*

(i) Fixed booster maximum noise power shall not exceed $-102.5 \text{ dBm/MHz} + 20 \text{ Log}_{10}(\text{Frequency})$, where Frequency is the uplink mid-band frequency of the supported spectrum bands in MHz.

(iii) Compliance with Noise limits will use instrumentation calibrated in terms of RMS equivalent voltage, and with booster input ports terminated or without input signals applied within the band of measurement.

3.7.1 Noise power in the presence of a downlink signal test procedure

- A. *Connect the EUT to the test equipment as shown in Figure 6 for uplink and Figure 7 for downlink. Ensure the coupled path of the RF coupler is connected to the spectrum analyzer.*
- B. *Configure the signal generator for 4.1 MHz AWGN operation for uplink test and 200 kHz 99% OBW AWGN for downlink test.*
- C. *Set the spectrum analyzer RBW for 1 MHz with the VBW $\geq 3X$ the RBW with an RMS AVERAGE detector with at least 100 traces averages.*
- D. *Set the center frequency of the spectrum analyzer to the center of the CMRS band under test with the span $\geq 2X$ the CMRS band. This shall include all spectrum blocks in the particular CMRS band under test (see Annex A). For uplink noise measurements, set the spectrum analyzer center frequency for the uplink band under test and tune the signal generator to the center of the paired downlink band. For downlink noise measurements, set the spectrum analyzer to the center of the downlink band and tune the signal generator to the upper or lower band-edge of the same band, ensuring that the maximum noise power is being measured.*
- E. *Measure the maximum Transmitter Noise Power Level when varying the downlink signal generator level from -90 to -10 dBm in 1 dB steps inside the RSSI dependent region and 10 dB steps outside the RSSI dependent region, report the six values closest to the limit with at least 2 points within the RSSI dependent region of the limit.*
- F. *Repeat A through E for all operational uplink and downlink bands.*

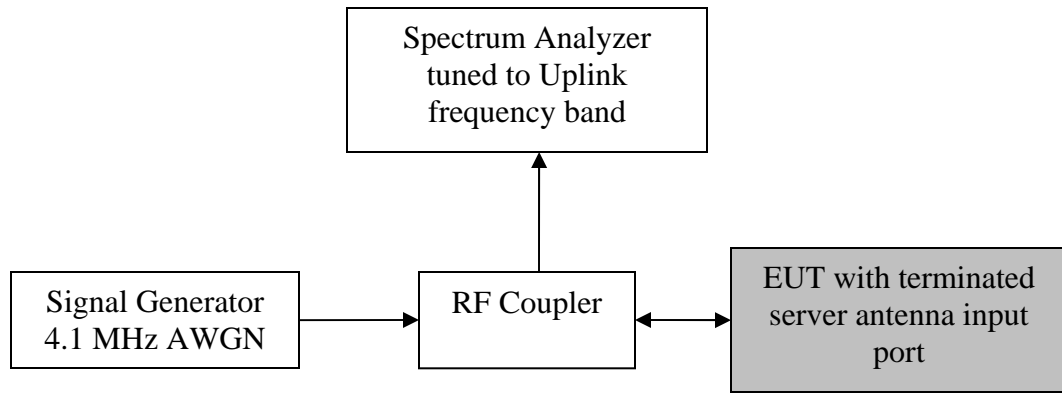


Figure 6: Test setup for uplink noise power measurement in the presence of a downlink signal

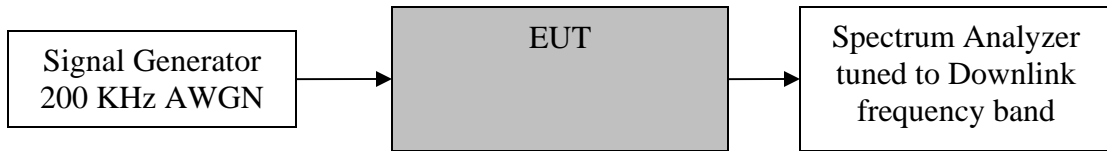


Figure 7: Test setup for downlink noise power measurement in the presence of a downlink signal

3.7.2 Test results for noise power in presence of downlink signal

Table 4: 800 MHz Uplink and downlink noise power in the presence of a downlink signal

Noise Limits 800 MHz				
RSSI (dBm)	Maximum Allowed (dBm/MHz)	Measured Uplink Noise (dBm/MHz)	Measured Downlink Noise (dBm/MHz)	Results
-90	-44.1	-52.5	-45.8	Pass
-80	-44.1	-53.0	-45.7	Pass
-70	-44.1	-52.8	-45.8	Pass
-60	-44.1	-53.1	-45.8	Pass
-55	-48	-59.1	-48.5	Pass
-50	-53	-63.6	-53.6	Pass

Table 5: 1900 MHz Uplink and downlink noise power in the presence of a downlink signal

Noise Limits 1900 MHz				
RSSI (dBm)	Maximum Allowed (dBm/MHz)	Measured Uplink Noise (dBm/MHz)	Measured Downlink Noise (dBm/MHz)	Results
-90	-37	-46.6	-38.2	Pass
-80	-37	-46.8	-37.8	Pass
-70	-37	-47.7	-38.0	Pass
-60	-43	-54.7	-43.6	Pass
-55	-48	-60.6	-48.8	Pass
-50	-53	-64.0	-53.9	Pass

Notes: RSSI dependent area shown in gray.

3.7.3 Maximum noise power test procedure

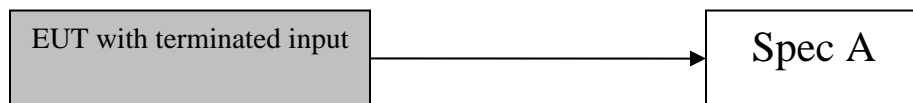


Figure 8: Noise limit instrumentation setup

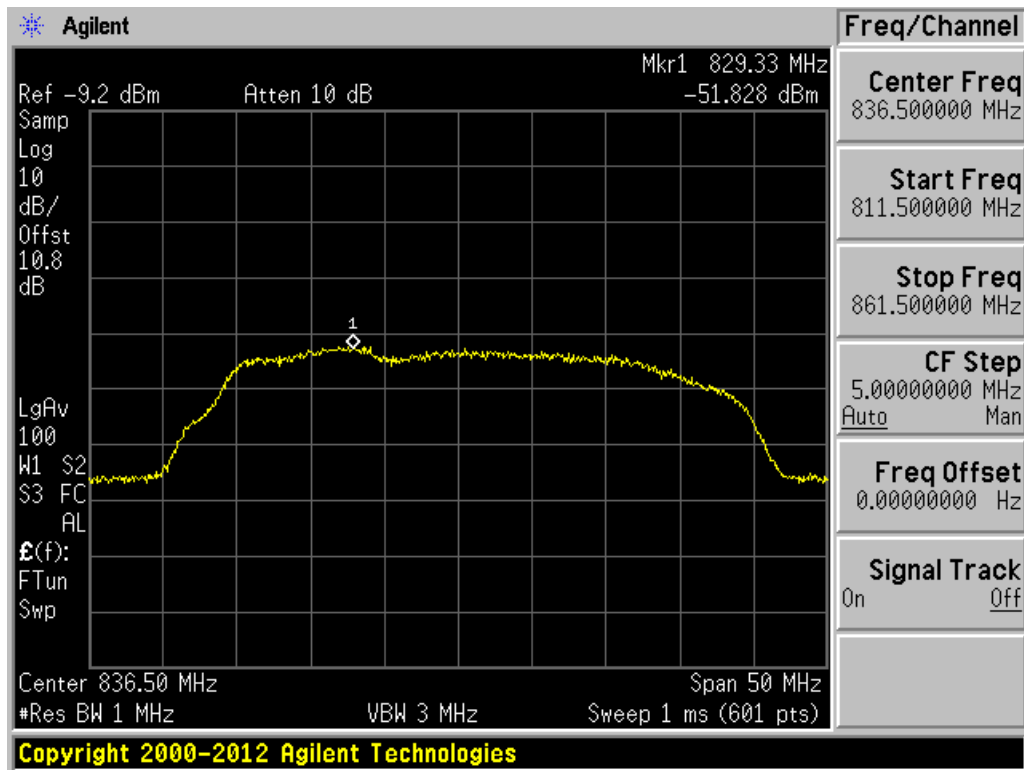
- A. Connect the EUT to the test equipment as shown in Figure 8. Begin with the uplink output connected to the spectrum analyzer.
- B. Set the spectrum analyzer RBW to 1 MHz with the VBW $\geq 3X$ RBW
- C. Select the power averaging (RMS) detector and trace average over at least 100 traces.
- D. Set the center frequency of the spectrum analyzer to the center of the CMRS band under test with the span $\geq 2X$ the CMRS band.
- E. Measure the maximum Transmitter Noise Power Level.
- F. Save the spectrum analyzer plot as necessary for inclusion in the final test report.
- G. Repeat steps A to F above for all operational uplink and downlink bands.

3.7.4 Maximum noise power test results

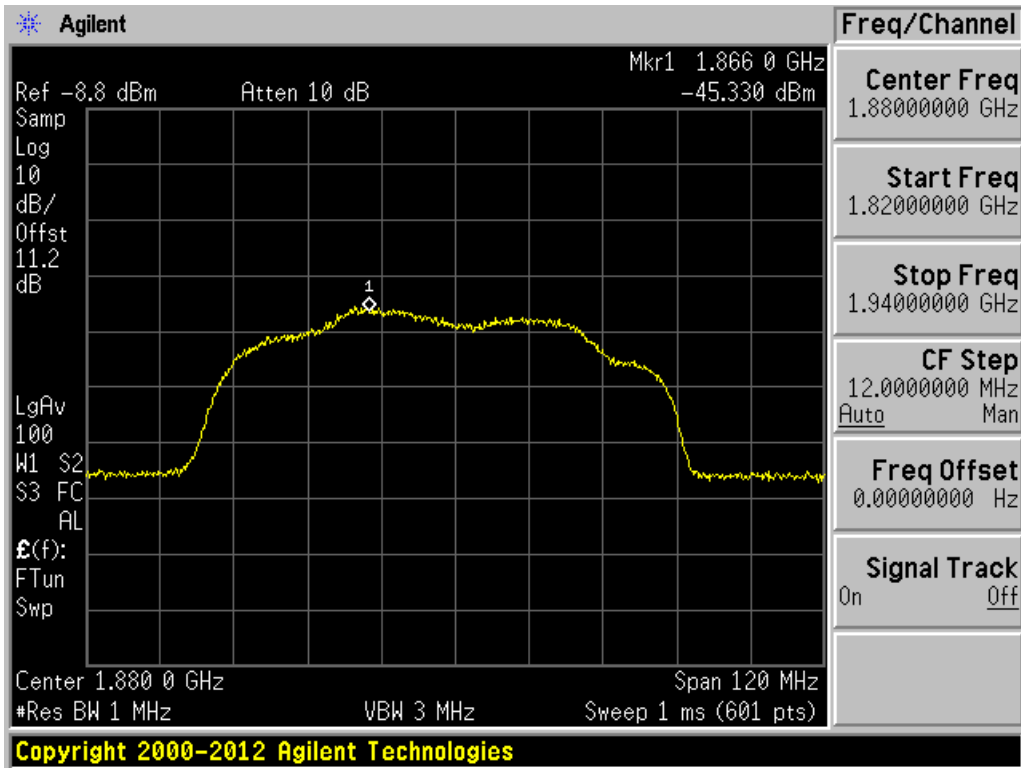
Spectrum Analyzer screenshots for EUT with terminated input ports. Output port connected to Spectrum Analyzer.

Table 6: Fixed booster maximum noise for band 5 (cellular) shell not exceed
 $-102 \text{ dBm/MHz} + 20 * \text{LOG10}(836.5 \text{ MHz}) = -44.1 \text{ dBm/MHz}$
 For band 2 (PCS) shell not exceed
 $-102 \text{ dBm/MHz} + 20 * \text{LOG10}(1880 \text{ MHz}) = -37.0 \text{ dBm/MHz}$

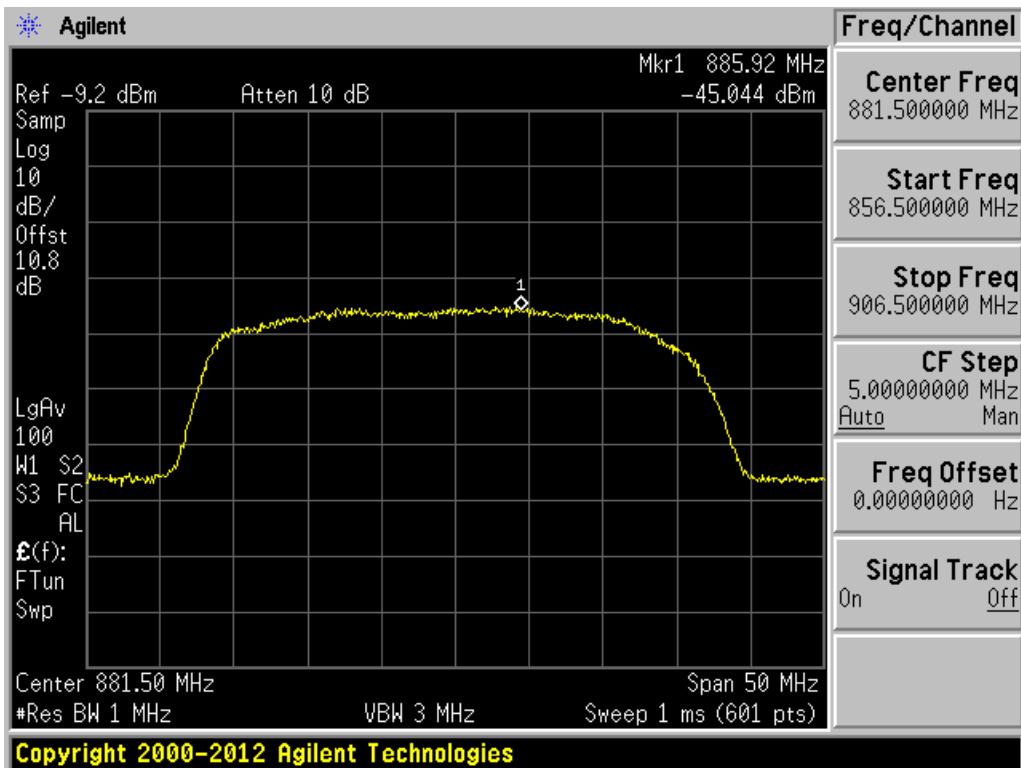
Fixed Booster Maximum Noise			
Frequency Band	Permitted Max Noise (dBm/MHz)	Measured Noise (dBm/MHz)	Result
800 MHz Uplink	-44.1	-51.8	Pass
800 MHz Downlink	-44.1	-45.0	Pass
1900 MHz Uplink	-37	-45.3	Pass
1900 MHz Downlink	-37	-37.7	Pass



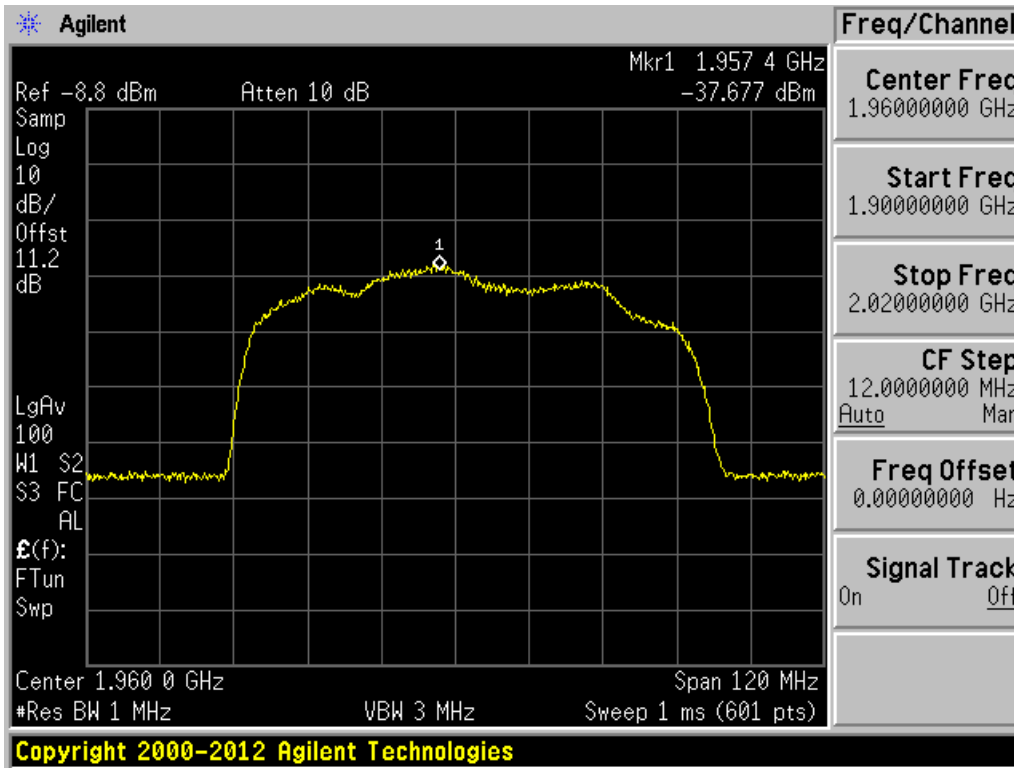
Uplink 800 MHz operational band



Uplink 1900 MHz operational band



Downlink 800 MHz operational band



Downlink 1900 MHz operational band

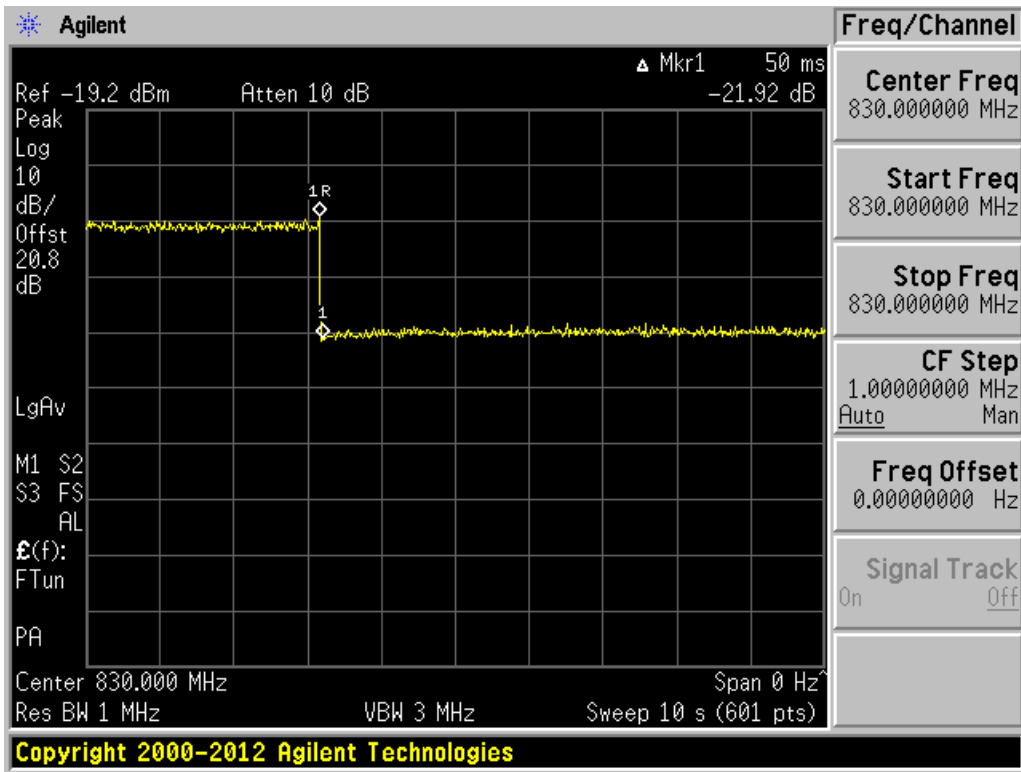
3.7.5 Uplink noise power timing test procedure.

- A. Connect the EUT to the test equipment as shown in Figure 6.
- B. Set the spectrum analyzer to the uplink frequency to be measured.
- C. Set the span to 0 Hz with a sweep time of 10 seconds.
- D. Set the power level of signal generator to the lowest level of the RSSI dependent noise.
- E. Set trace of spectrum analyzer for MAX HOLD and increase the power level of signal generator 1 by 10 dB for mobile boosters and 20 dB for fixed boosters.
- F. Ensure that the Uplink noise decrease to the specified levels within 1 second for mobile devices and 3 seconds for fixed devices.
- G. Repeat A – E for all operational uplink bands.

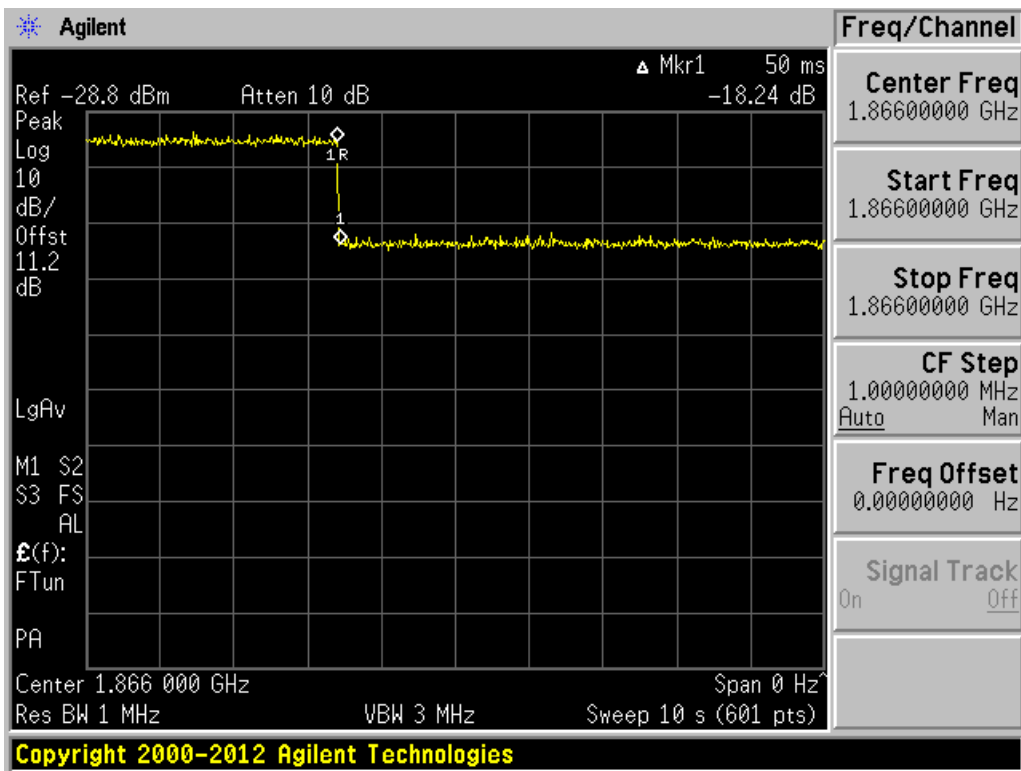
3.7.6 Uplink noise power timing test results.

Table 7: Uplink noise timing

Fixed Booster Variable Uplink Noise Timing			
Frequency Band	Permitted Max Time (s)	Measured Time (s)	Result
800 MHz Uplink	3	0.05	Pass
1900 MHz Uplink	3	0.05	Pass



800 MHz uplink noise power timing



1900 MHz uplink noise power timing

3.8 Uplink Inactivity Test

(Reference: KDB #935210 D03, § 7.8)

Rule paragraph(s):

§ 20.21(e)(8)(i)(I) Uplink Inactivity. When a consumer booster is not serving an active device connection after 5 minutes the uplink noise power shall not exceed -70 dBm/MHz.

3.8.1 Uplink inactivity test procedure

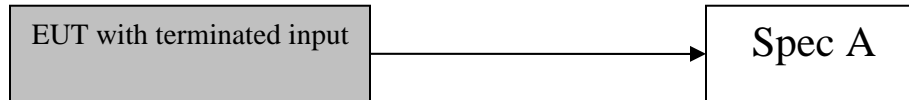
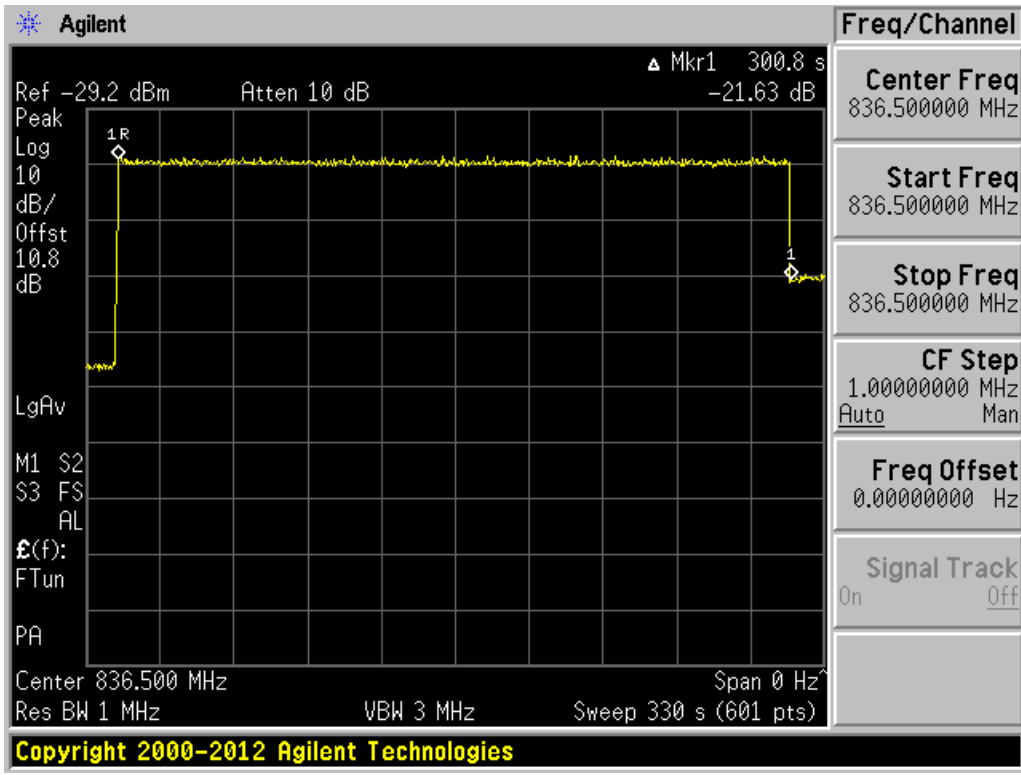


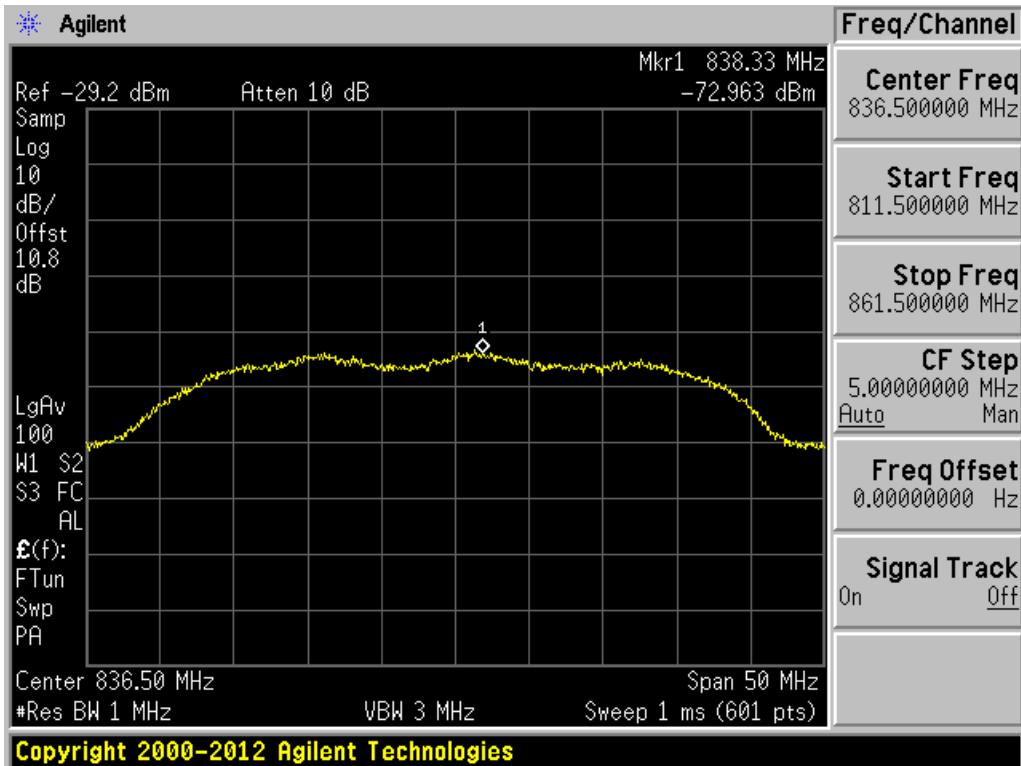
Figure 9: Uplink inactivity test setup

- A. Connect the EUT to the test equipment as shown in Figure 9 with the uplink output connected to the spectrum analyzer.
- B. Select the RMS power averaging detector.
- C. Set the spectrum analyzer RBW for 1 MHz with the VBW $\geq 3X$ RBW.
- D. Set the center frequency of the spectrum analyzer to the center of the uplink operational band.
- E. Set the span for 0 Hz with a single sweep time for a minimum of 330 seconds.
- F. Start to capture a new trace using MAX HOLD.
- G. After approximately 15 seconds turn on the EUT power.
- H. Once the full spectrum analyzer trace is complete place a MARKER on the leading edge of the pulse and use the DELTA MARKER METHOD to measure the time until the uplink was squelched.
- I. Ensure the noise level for the squelched signal is below the uplink inactivity noise power limit, as specified by the rules.
- J. Capture the plot for inclusion in the test report.
- K. Set the spectrum analyzer RBW to 1 MHz with the VBW $\geq 3X$ RBW
- L. Select the power averaging (RMS) detector and trace average over at least 100 traces.
- M. Set the center frequency of the spectrum analyzer to the center of the CMRS band under test with the span $\geq 2X$ the CMRS band.
- N. Measure the maximum Transmitter Noise Power Level.
- O. Save the spectrum analyzer plot as necessary for inclusion in the final test report.
- P. Repeat steps A to O for all operational uplink bands.

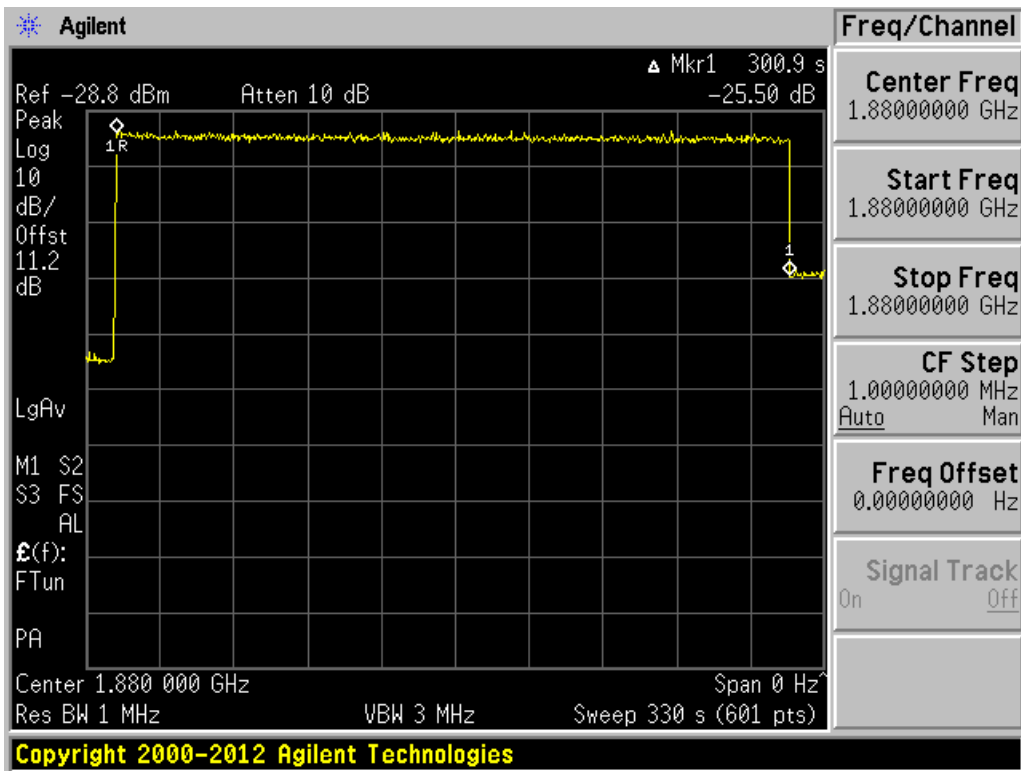
3.8.2 Uplink inactivity test results



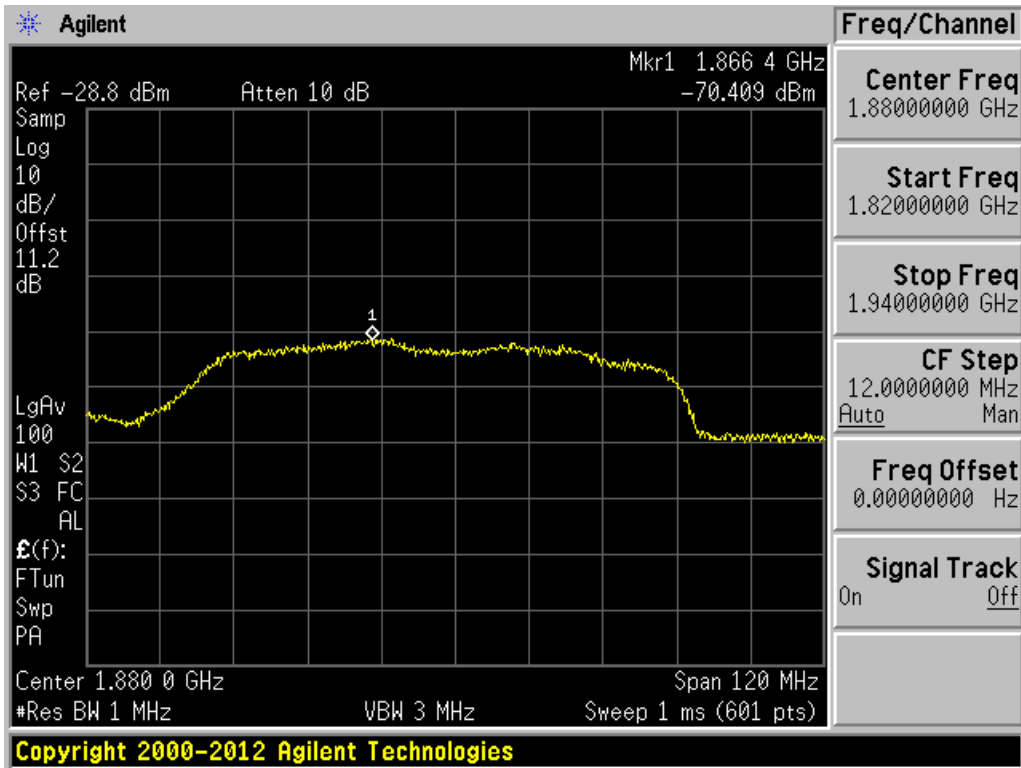
836.5 MHz uplink inactivity timing test



836.5 MHz uplink inactivity noise power test



1880 MHz uplink inactivity timing test



1880 MHz uplink inactivity noise power test

3.9 Variable Booster Gain Test

(Reference: KDB #935210 D03, § 7.9)

Rule paragraph(s):

§ 20.21(e)(8)(i)(C)(1) *Booster Gain Limits.* (1) *The uplink gain in dB of a consumer booster referenced to its input and output ports shall not exceed $-34\text{dB} - \text{RSSI} + \text{MSCL}$.*

(i) *Where RSSI is the downlink composite received signal power in dBm at the booster donor port for all base stations in the band of operation. RSSI is expressed in negative dB units relative to 1 mW.*

(ii) *Where MSCL (Mobile Station Coupling Loss) is the minimum coupling loss in dB between the wireless device and input port of the consumer booster. MSCL must be calculated or measured for each band of operation and provided in compliance test reports.*

3.9.1 Variable booster gain test procedure

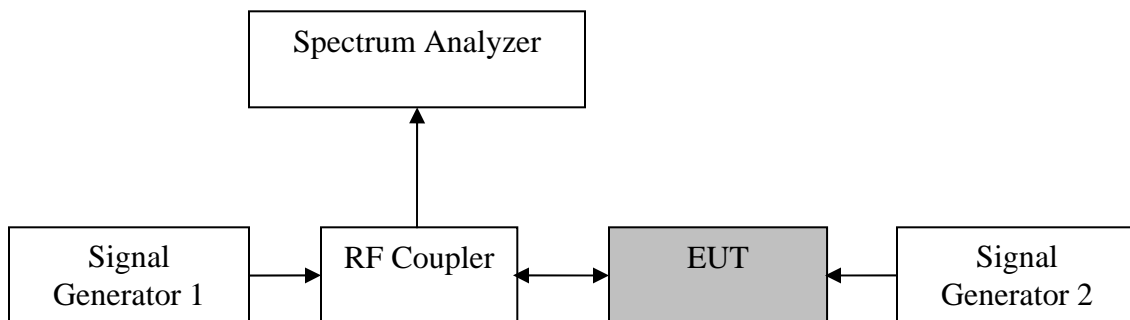


Figure 10: Variable uplink gain test setup

- A. Connect the EUT to the test equipment as shown in Figure 10 with the uplink output connected to signal generator 1. Ensure the coupled path of the RF coupler is connected to the spectrum analyzer.
- B. Configure downlink signal generator #1 for AWGN operation with 99% occupied bandwidth of 4.1 MHz tuned to the center of the downlink operational band.
- C. Set the power level and frequency of signal generator #2 to a value 5 dB below the AGC level from section 3.4. The signal type is AWGN with a 99% OBW of 4.1 MHz.
- D. Set span to at least 10 MHz.
- E. Set RBW = 100 kHz and VBW \geq 300 kHz.
- F. Select the CHANNEL POWER measurement tool.
- G. Select the RMS (power averaging) detector.
- H. Ensure that the number of measurement points per sweep $\geq (2 \times \text{span})/\text{RBW}$.
- I. Sweep time = auto couple or as necessary.
- J. Trace average at least 10 traces in power averaging (i.e., RMS) mode.

- K. Measure the maximum channel power and compute maximum gain when varying the signal generator 1 to a level from -90 to -20 dBm in 1 dB steps inside the RSSI dependent region and 10 dB steps outside the RSSI dependent region and report the six values closest to the limit, including at least two points from within the RSSI dependent region of operation.*
- L. Repeat A to K for all operational uplink bands.*

3.9.2 Variable booster gain test results

Table 8: Variable booster gain

Uplink Variable Gain 828 MHz					
RSSI (dBm)	MSCL (dB)	P in (dBm)	P out (dBm)	Gain	Maximum Permitted Gain (dB)
-90	33.5	-47.5	10.8	58.3	64.9
-80	33.5	-47.5	10.8	58.3	64.9
-70	33.5	-47.5	10.8	58.3	64.9
-60	33.5	-47.5	10.7	58.2	59.5
-55	33.5	-47.5	6.0	53.5	54.5
-50	33.5	-47.5	1.2	48.7	49.5
Uplink Variable Gain 1866.8 MHz					
RSSI (dBm)	MSCL (dB)	P in (dBm)	P out (dBm)	Gain	Maximum Permitted Gain (dB)
-90	42.3	-48.5	15.6	64.1	72
-80	42.3	-48.5	15.6	64.1	72
-70	42.3	-48.5	15.6	64.1	72
-60	42.3	-48.5	5.8	54.3	68.3
-55	42.3	-48.5	0.5	49.0	63.3
-50	42.3	-48.5	-3.5	45.0	58.3

Note: RSSI dependant area shown in gray.

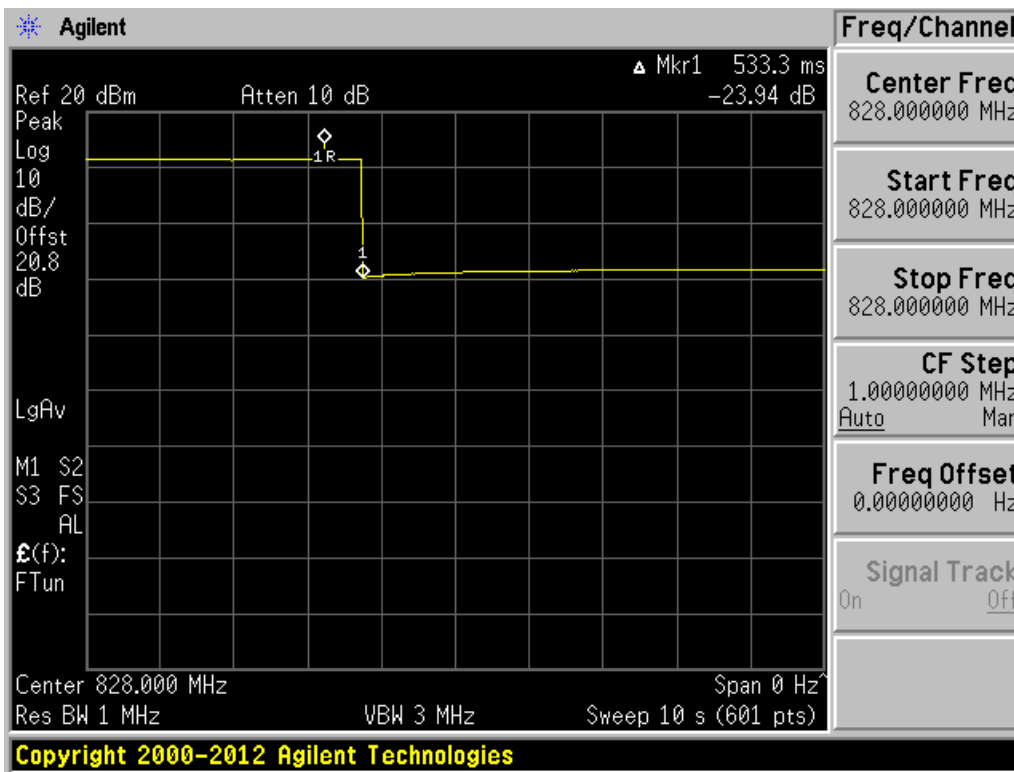
3.9.3 Variable uplink gain timing test procedure

- A. Set the spectrum analyzer to the uplink frequency to be measured.*
- B. Set the span to 0 Hz with a sweep time of 10 seconds.*
- C. Set the power level of signal generator 1 to the lowest level of the RSSI dependent gain.*
- D. Select MAX HOLD and increase the power level of signal generator 1 by 10 dB for mobile booster and 20 dB for fixed indoor boosters.*
- E. Ensure that the Uplink gain decrease to the specified levels within 1 second for mobile devices and 3 seconds for fixed devices.*
- F. Repeat A to E for all operational uplink bands.*

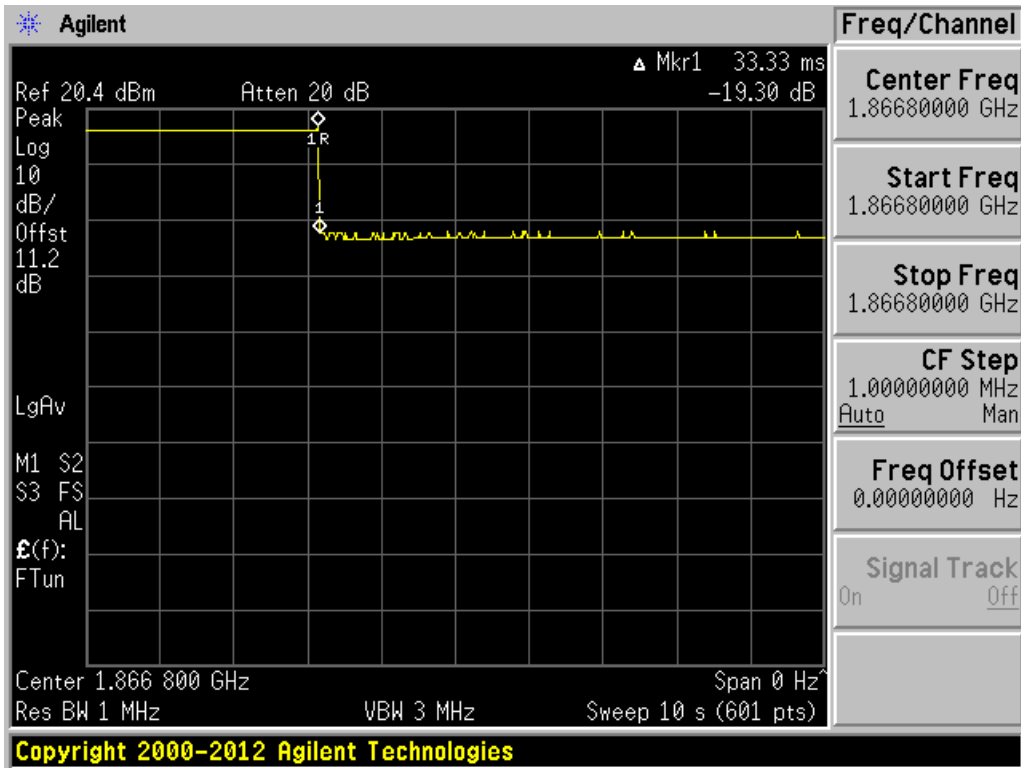
3.9.4 Variable uplink gain timing test results

Table 9: Variable gain timing

Variable Gain Timing			
Operational Band	Maximum Permitted (s)	Measured Time (s)	Result
800 Tx	3	0.533	Pass
1900 Tx	3	0.033	Pass



Uplink 828 MHz band variable gain timing



Uplink 1866.8 MHz band variable gain timing

3.10 Occupied Bandwidth Test

(Reference: KDB #935210 D03, § 7.10)

Rule paragraph(s):

§ 2.1049 Occupied bandwidth.

3.10.1 Occupied bandwidth test procedure

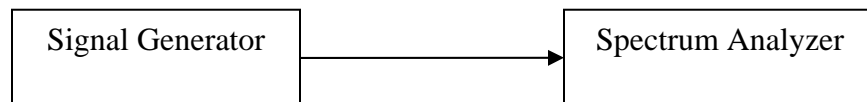


Figure 11

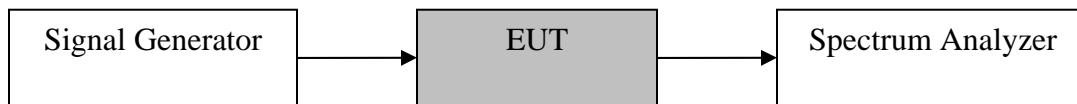
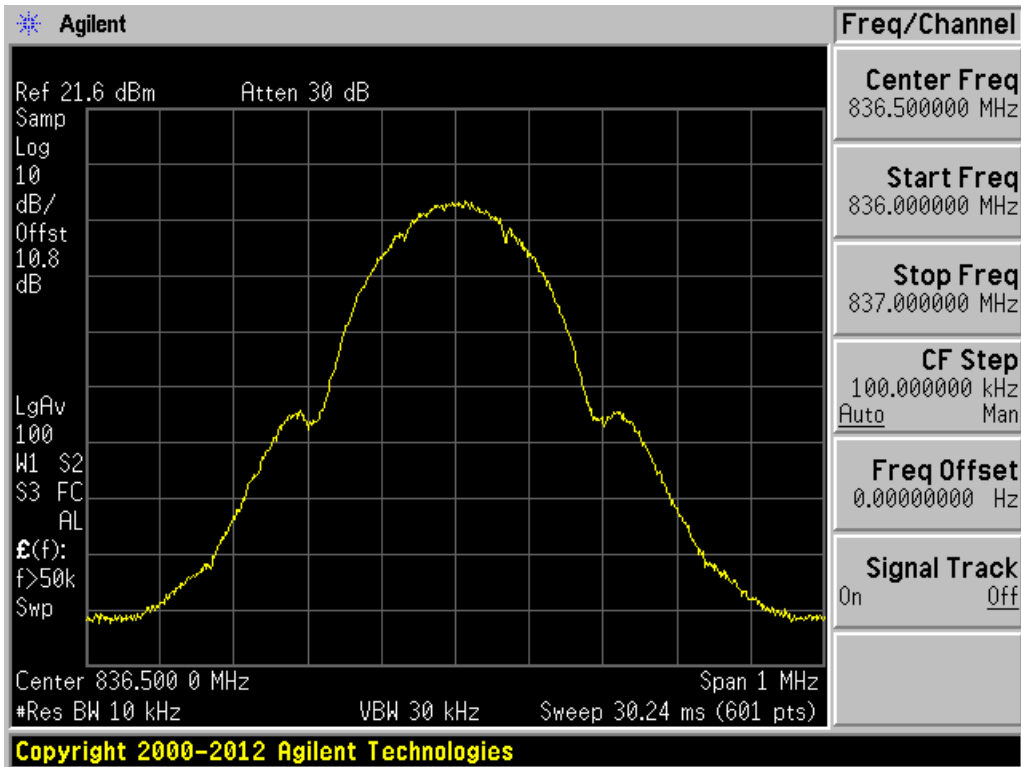


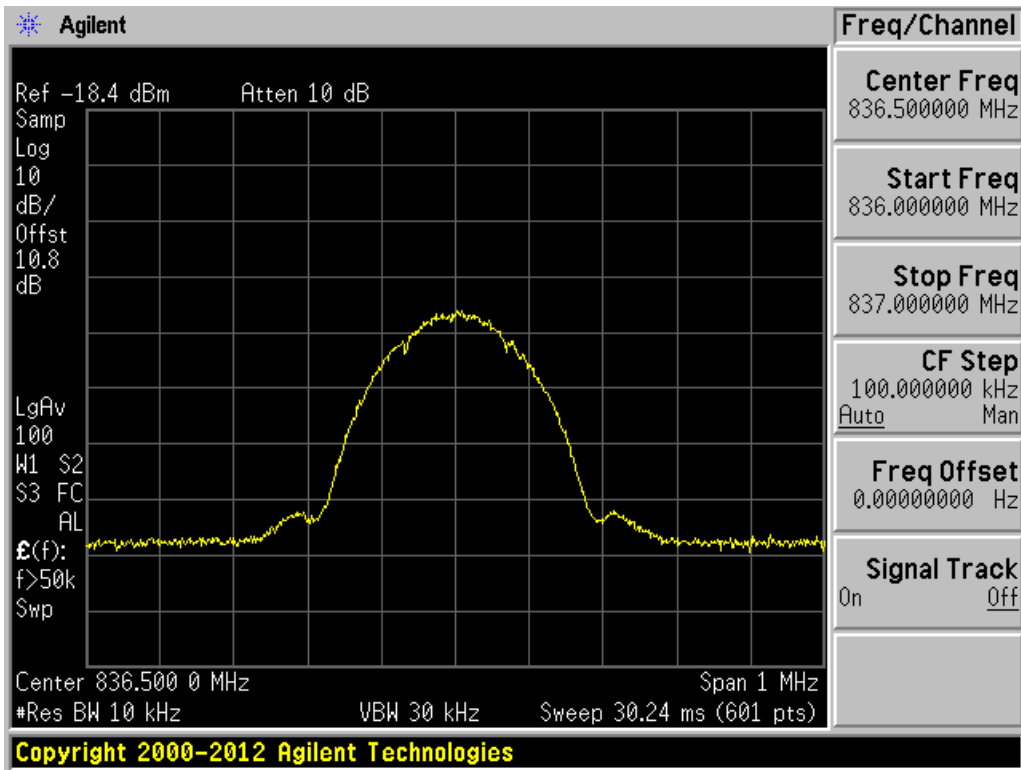
Figure 12

- A. Connect the test equipment as shown in Figure 11 to measure the characteristics of the test signals produced by the signal generator.
- B. Set VBW to $\geq 3X$ RBW
- C. Set the center frequency of the spectrum analyzer to the center of the operational band. The span will be adjusted for each modulation type and occupied bandwidth as necessary for accurately viewing the signals.
- D. Set the signal generator for power level to match the values obtained in section 3.3.
- E. Set the signal generator modulation type for GSM with a PBRS pattern and allow the trace on the signal generator to stabilize adjusting the span as necessary.
- F. Set the spectrum analyzer RBW for 1% to 5% of the emissions bandwidth with an RMS AVERAGE detector with at least 100 traces averages.
- G. Save the spectrum analyzer trace for inclusion in the test report. This represents input signal to the EUT.
- H. Connect the test equipment as shown in Figure 12 and repeat steps B to F.
- I. Capture the spectrum analyzer traces for inclusion in the test report. This represents output signal of the EUT.
- J. Repeat steps A to I for CDMA, WCDMA and LTE modulation, adjusting the span as necessary for all uplink and downlink operational bands.

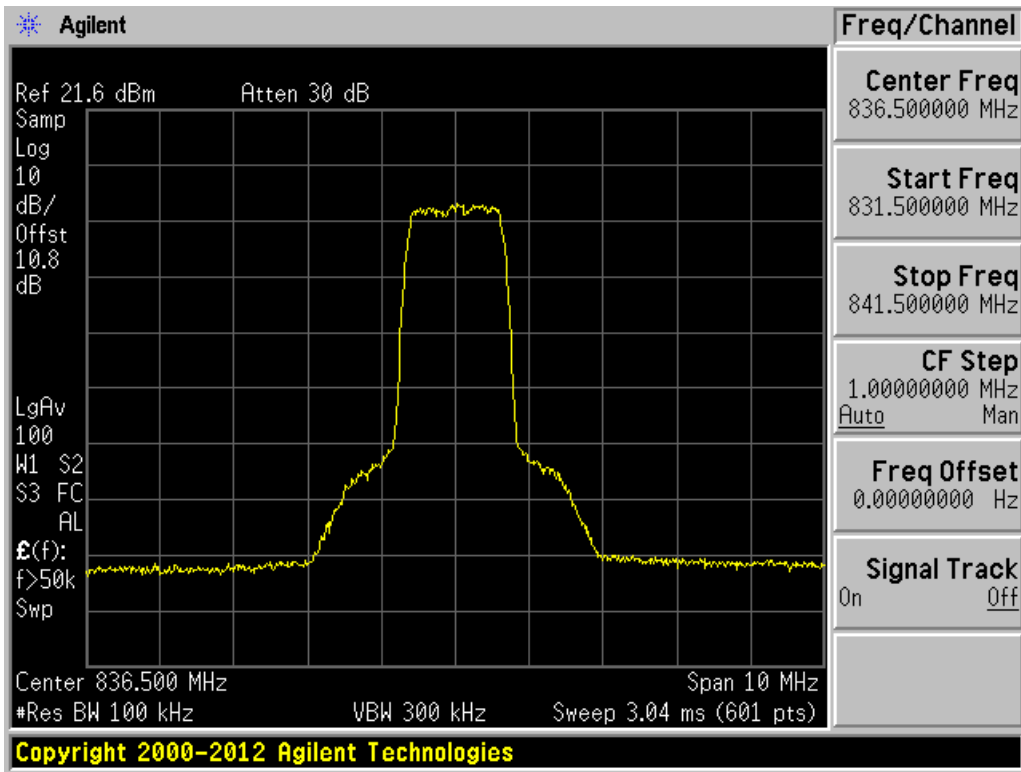
3.10.2 Occupied bandwidth Test Results.



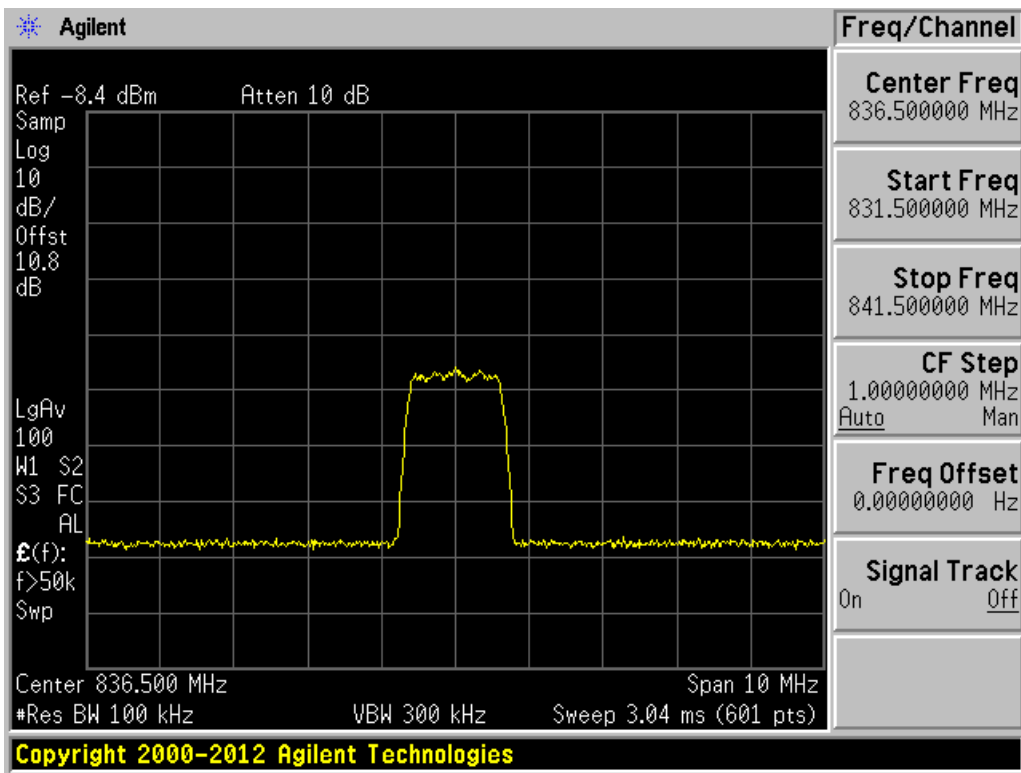
Uplink GSM 836.5 MHz Output.



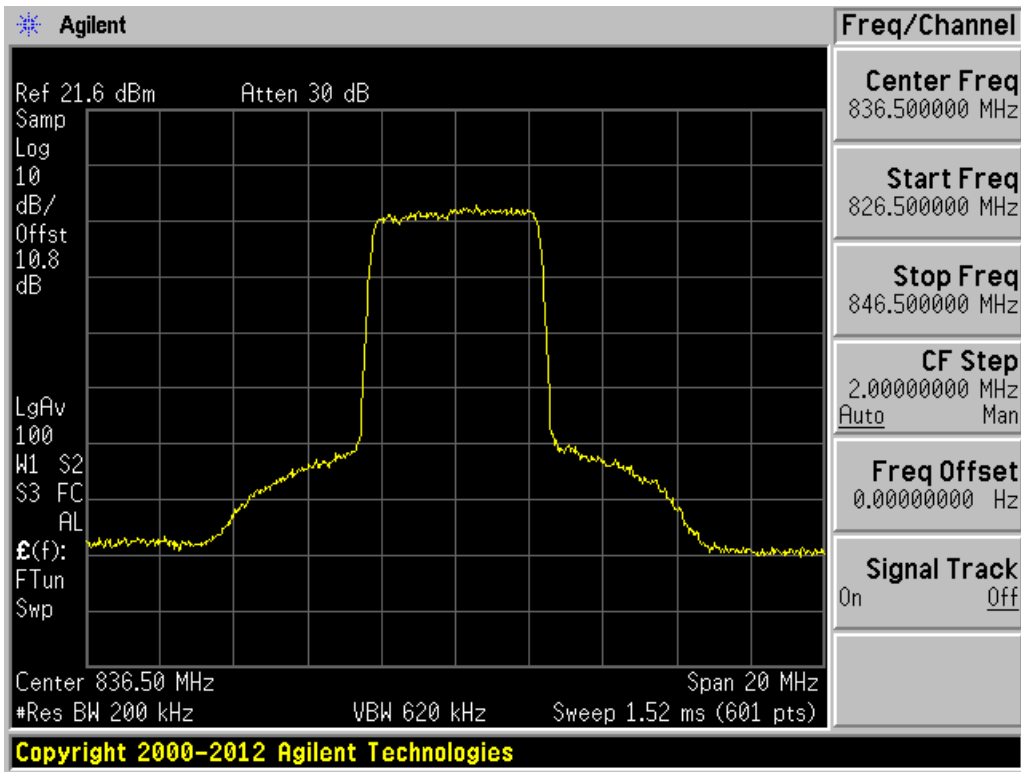
Uplink GSM 836.5 MHz Input.



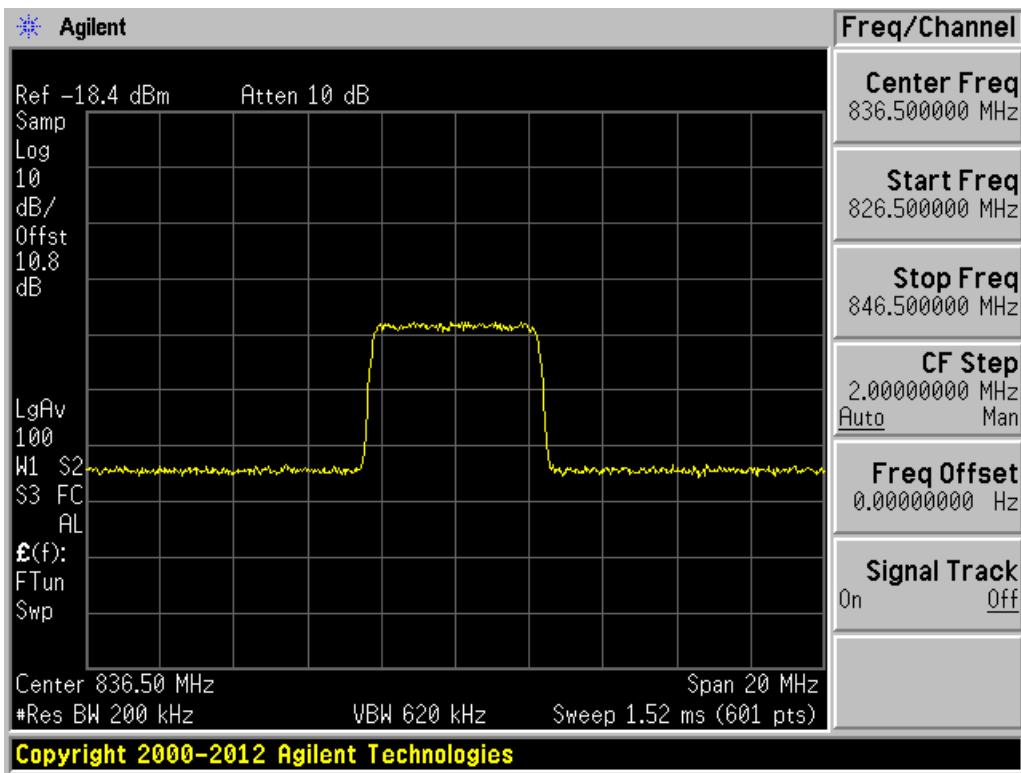
Uplink CDMA 836.5 MHz Output.



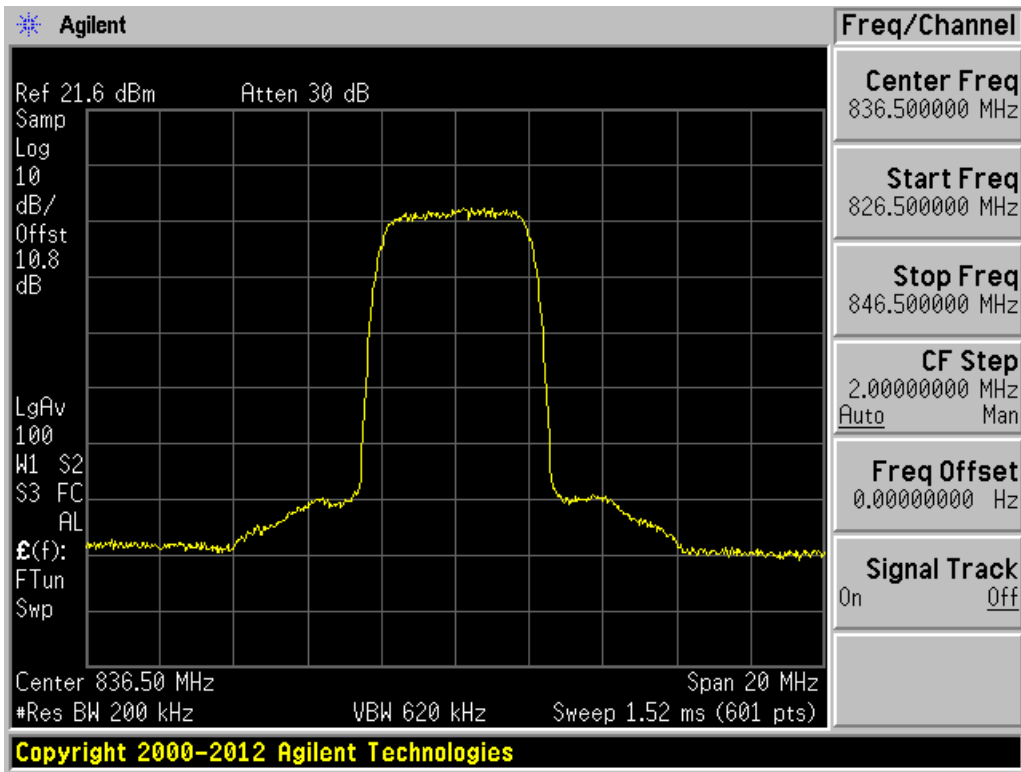
Uplink CDMA 836.5 MHz Input.



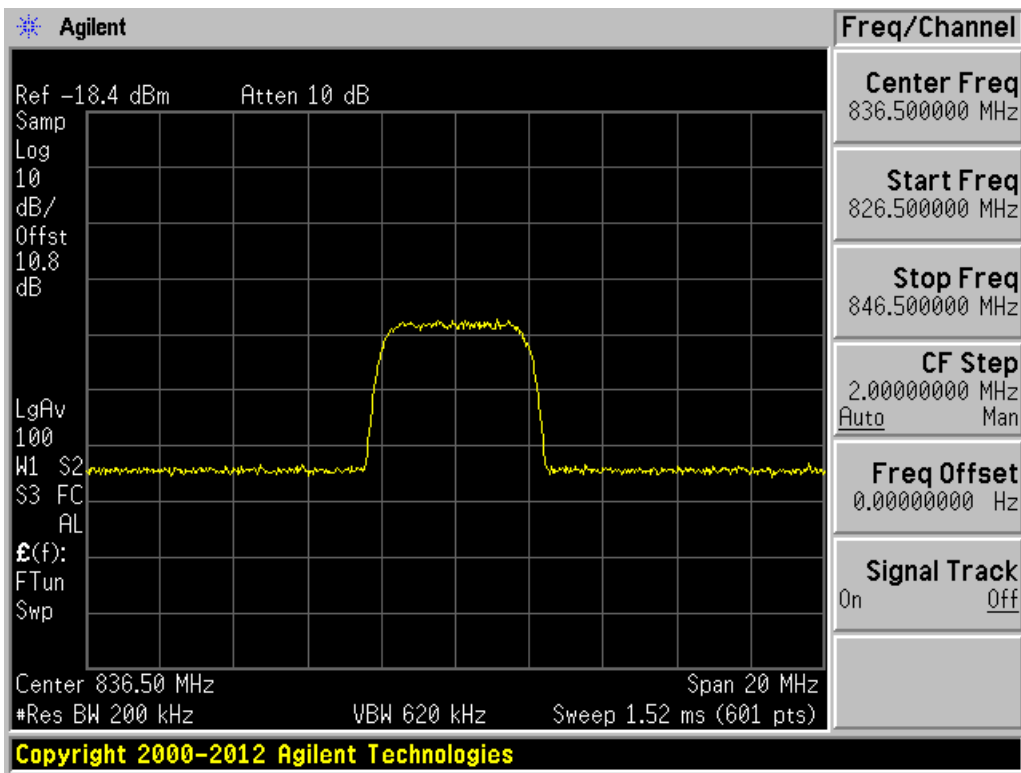
Uplink LTE 836.5 MHz Output.



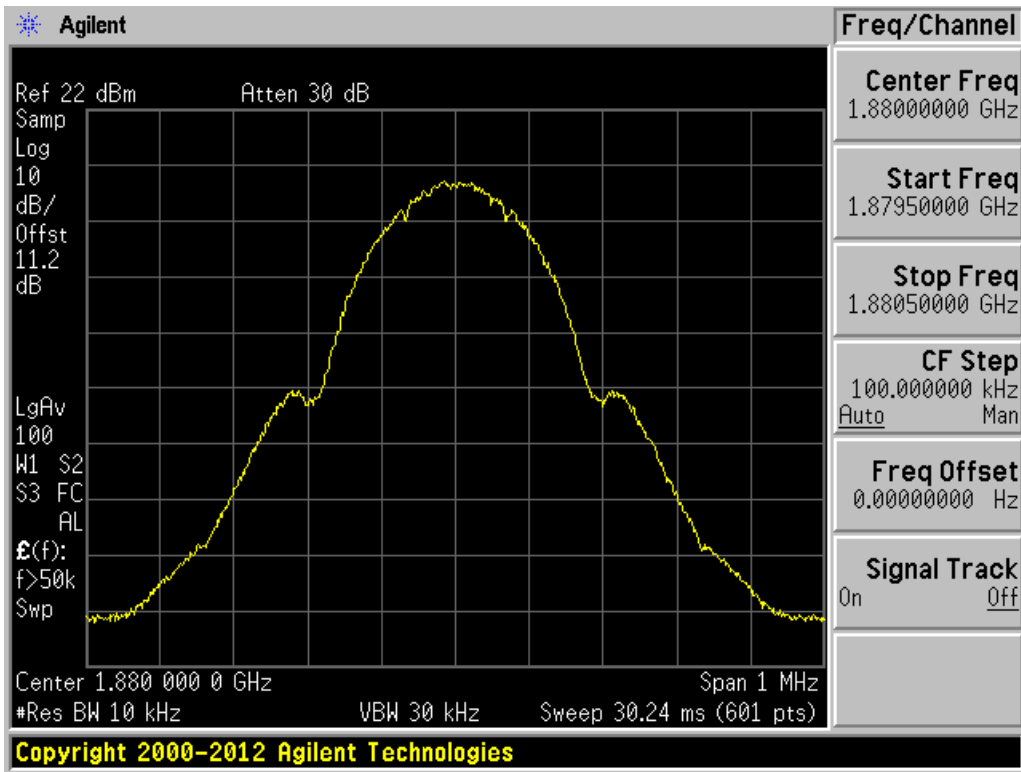
Uplink LTE 836.5 MHz Input.



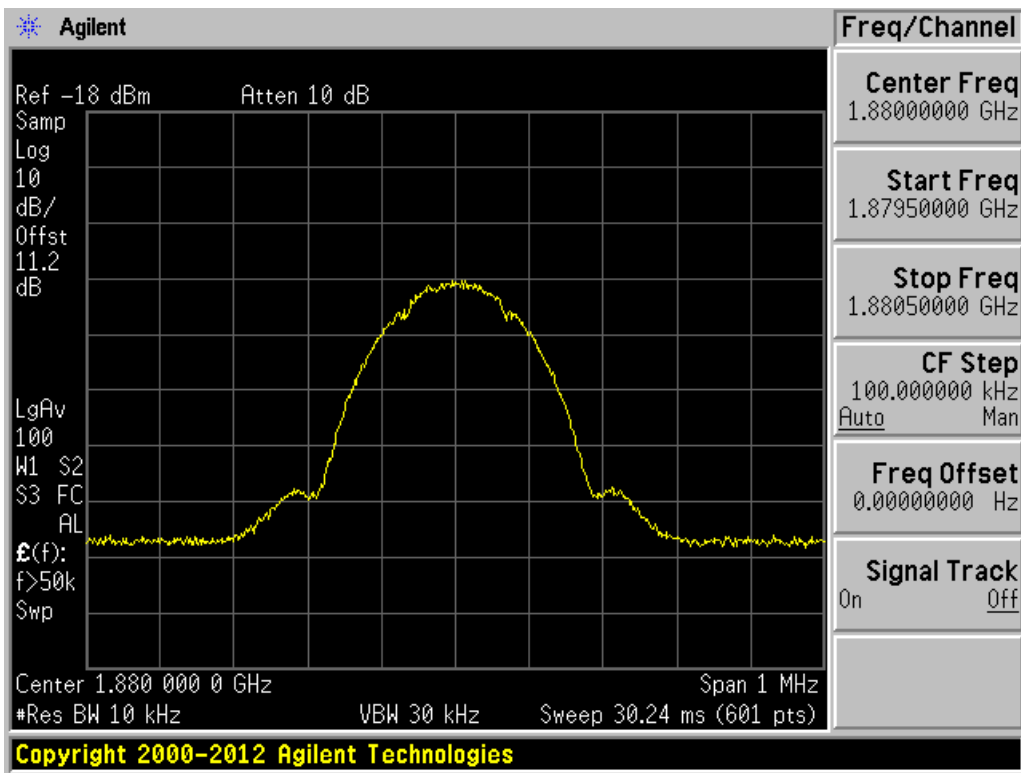
Uplink WCDMA 836.5 MHz Output.



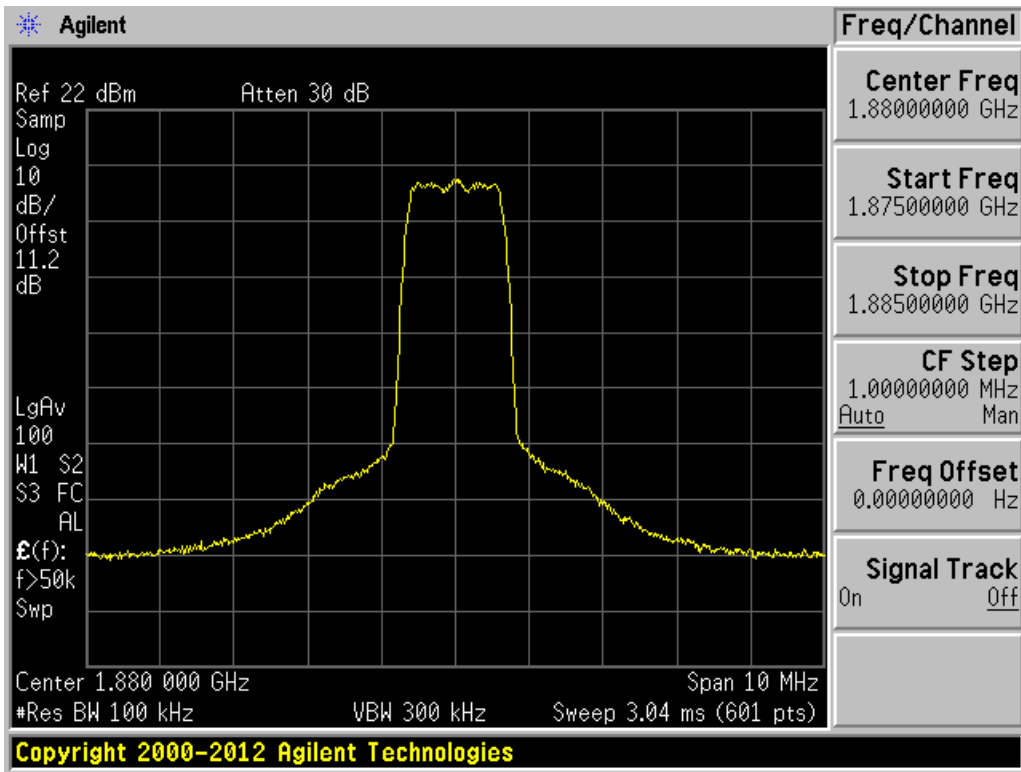
Uplink WCDMA 836.5 MHz Input.



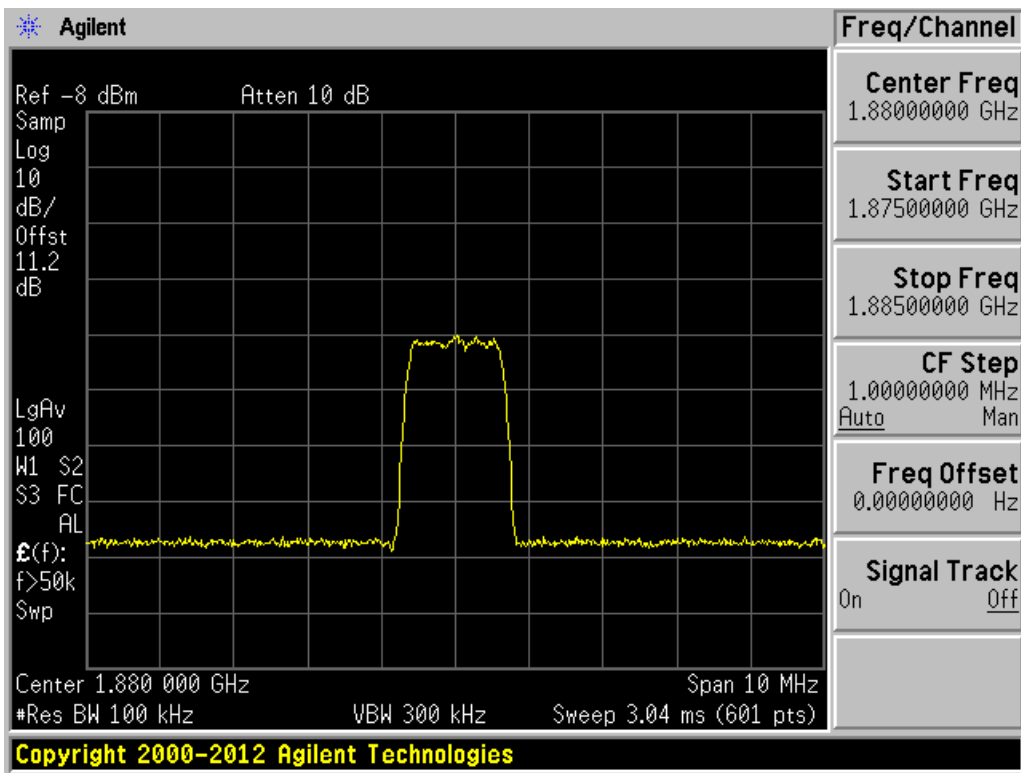
Uplink GSM 1880 MHz Output.



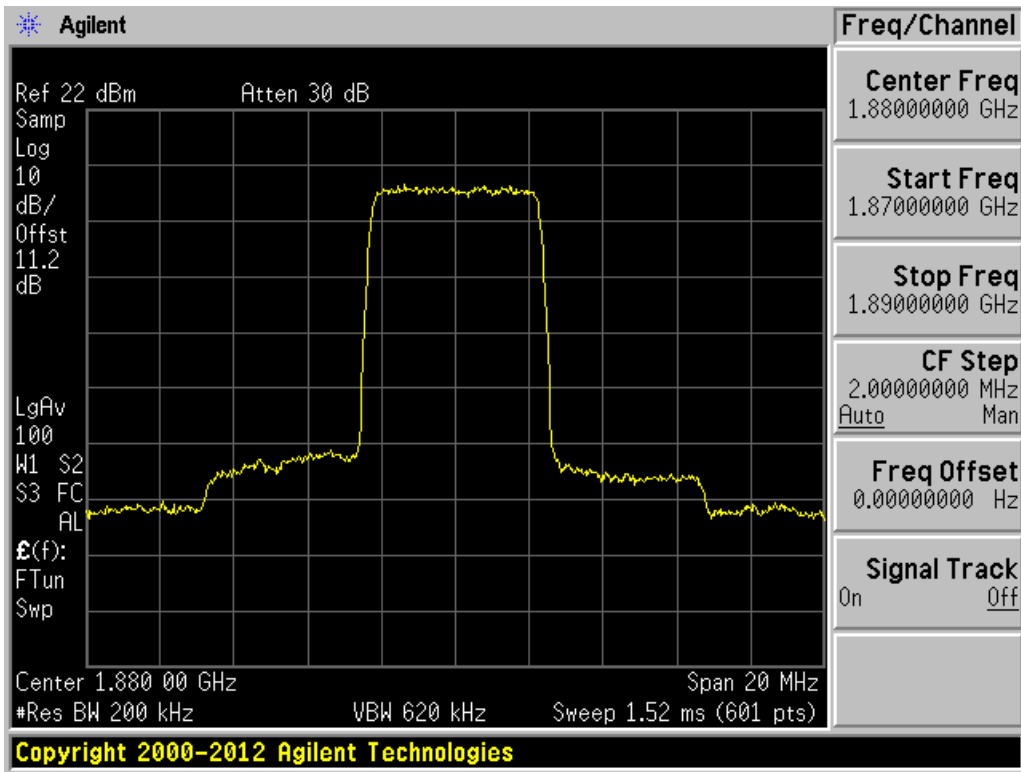
Uplink GSM 1880 MHz Input.



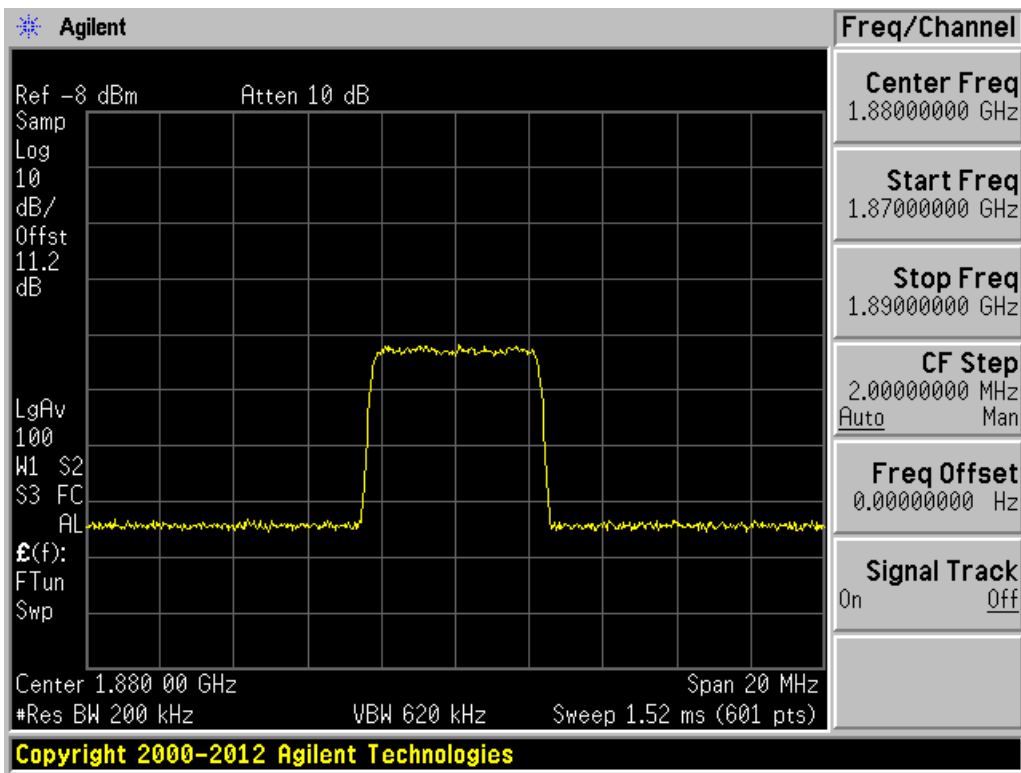
Uplink CDMA 1880 MHz Output.



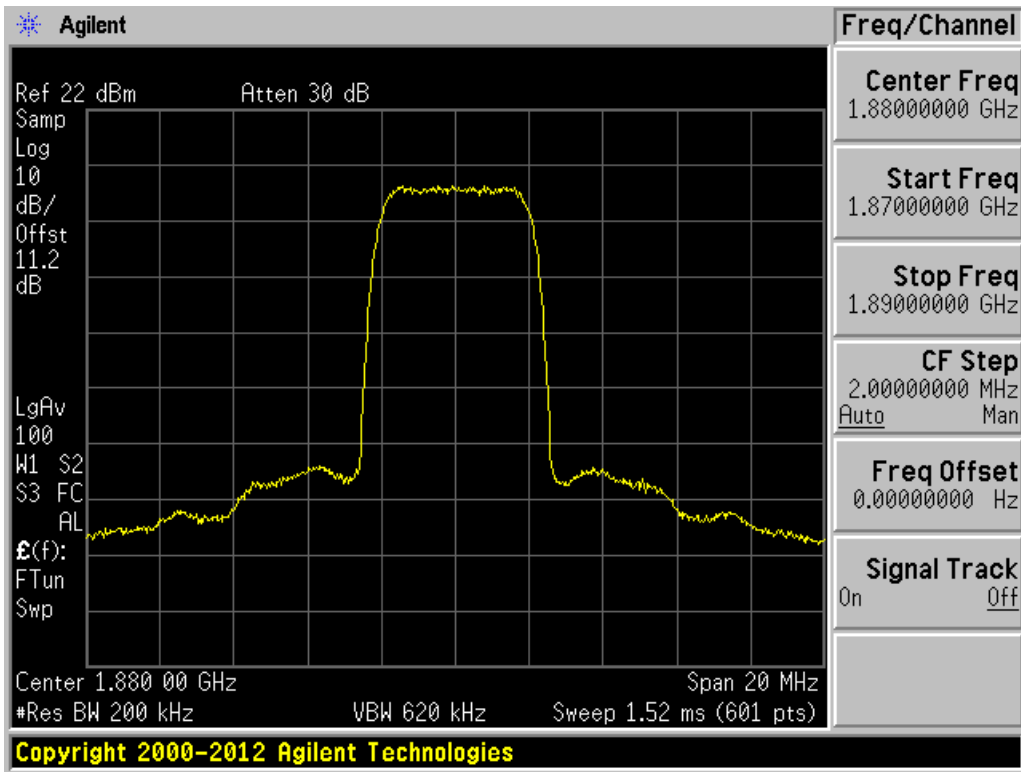
Uplink CDMA 1880 MHz Input.



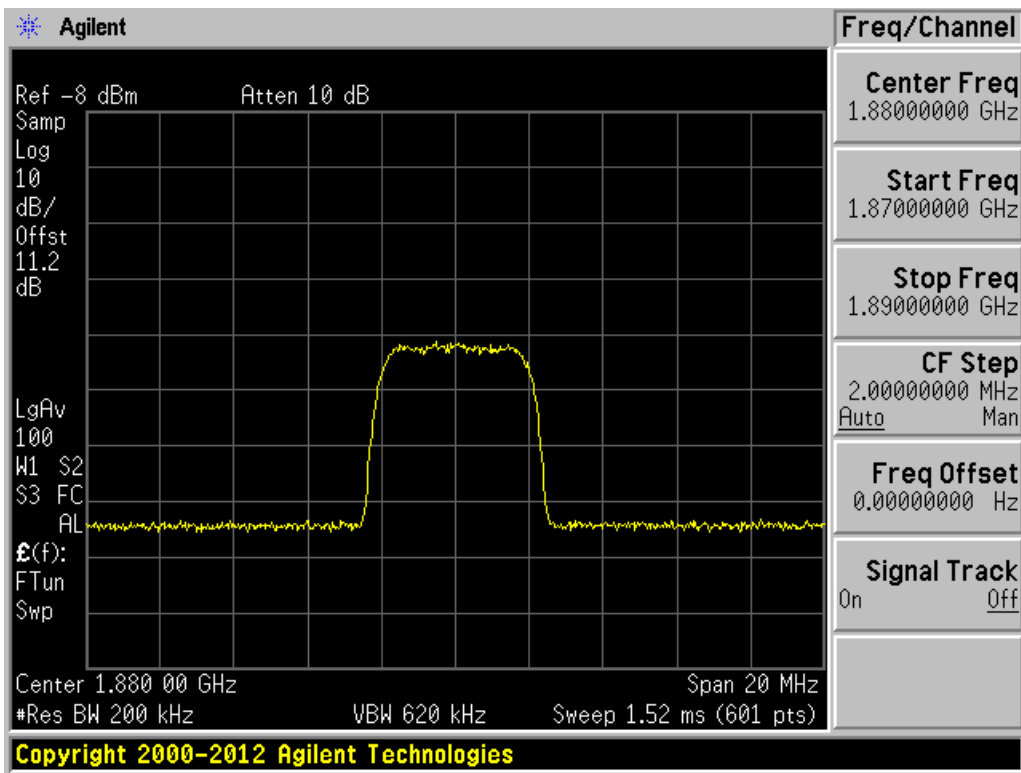
Uplink LTE 1880 MHz Output.



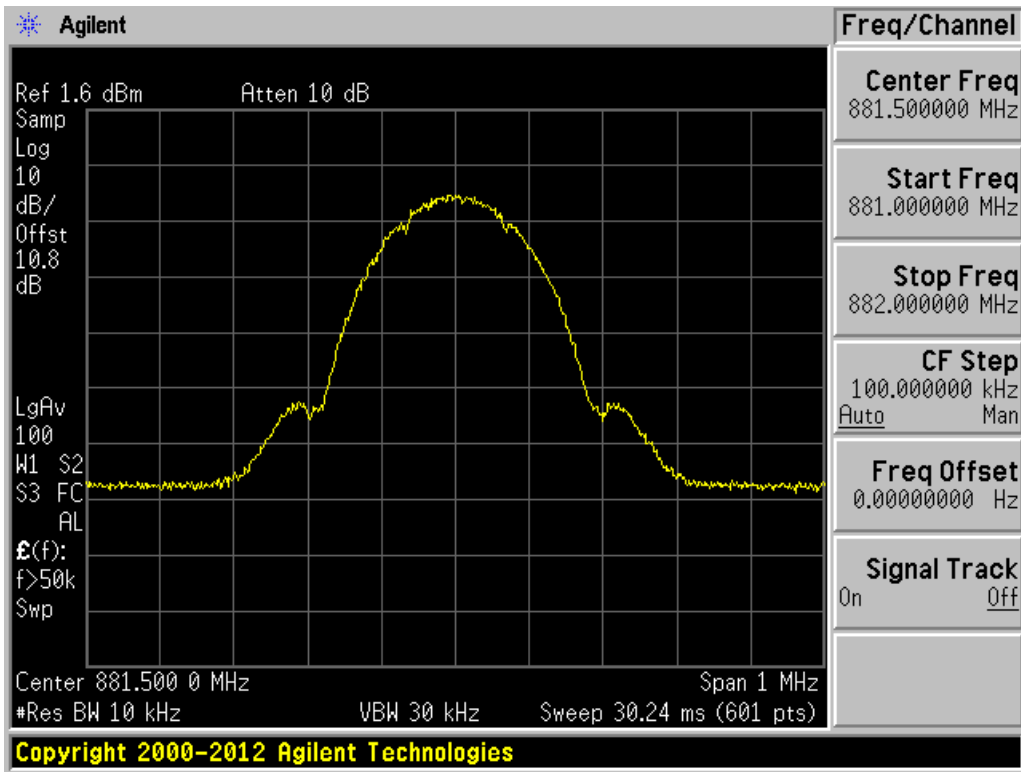
Uplink LTE 1880 MHz Input.



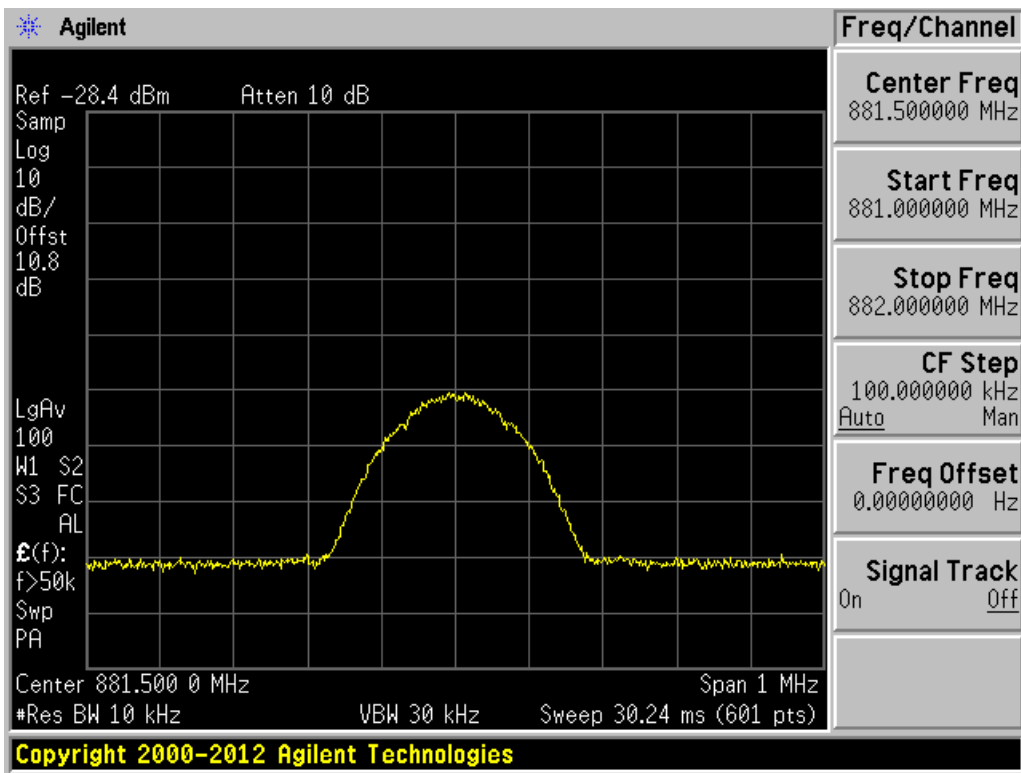
Uplink WCDMA 1880 MHz Output.



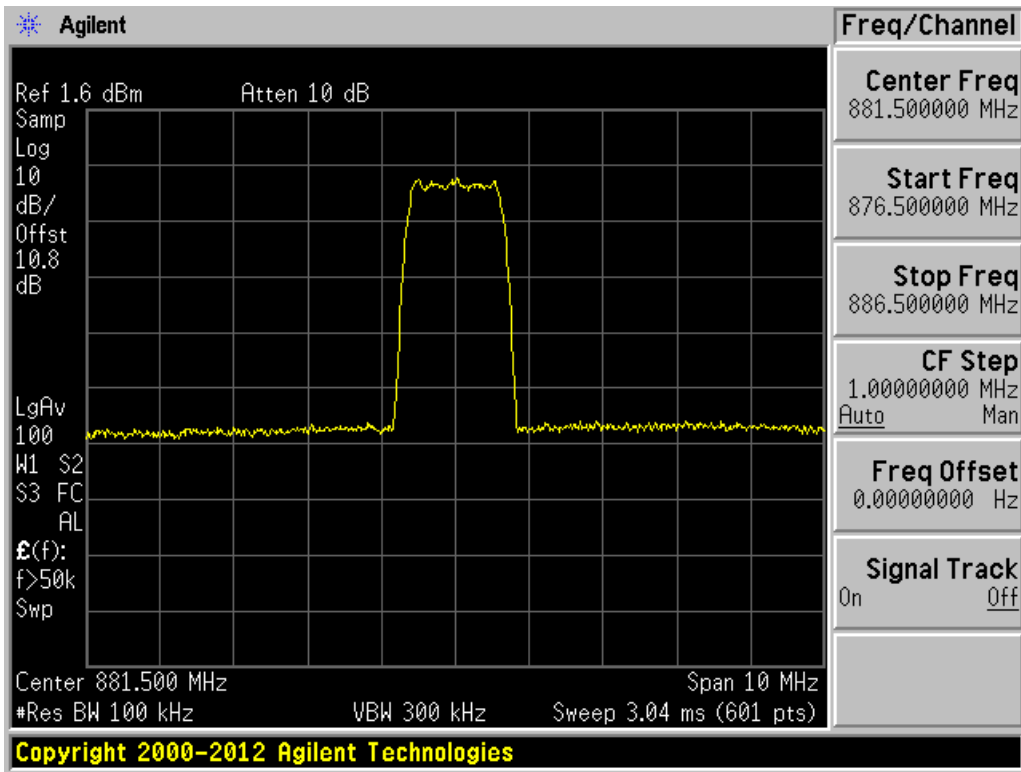
Uplink WCDMA 1880 MHz Input.



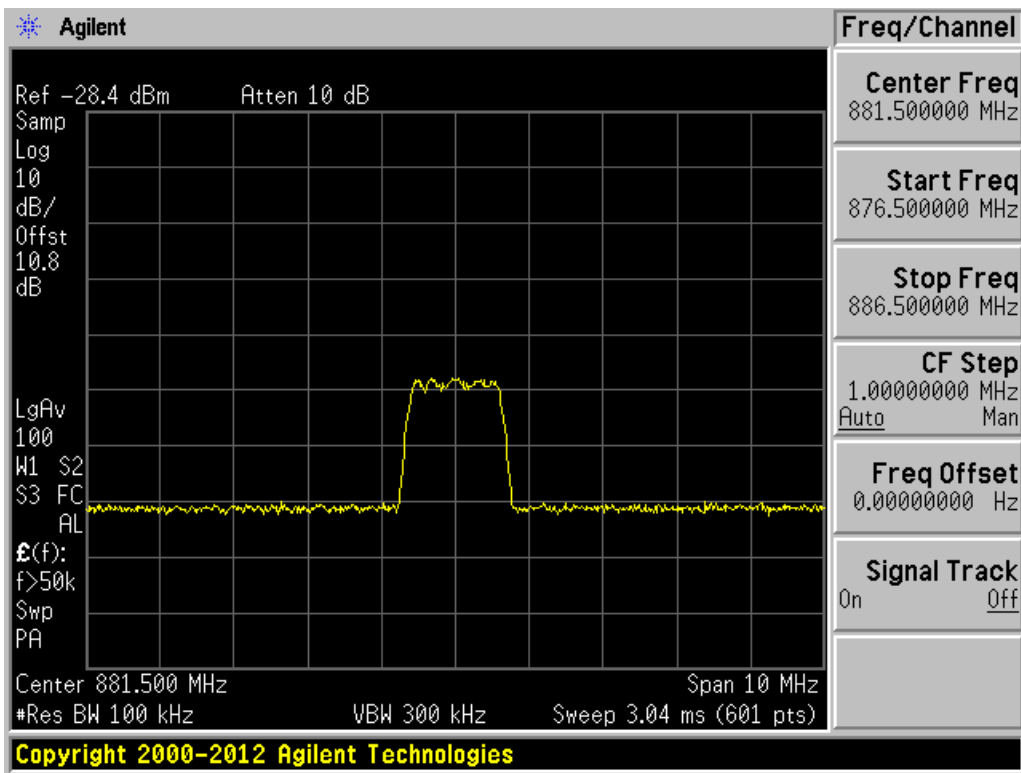
Downlink GSM 881.5 MHz Output.



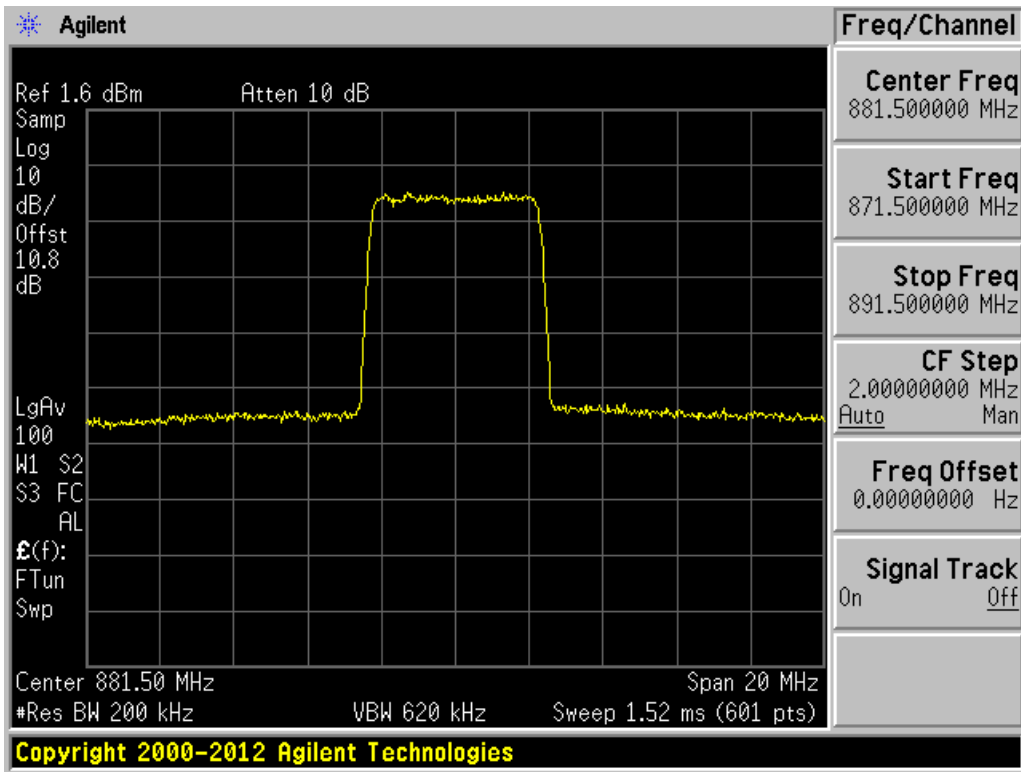
Downlink GSM 881.5 MHz Input.



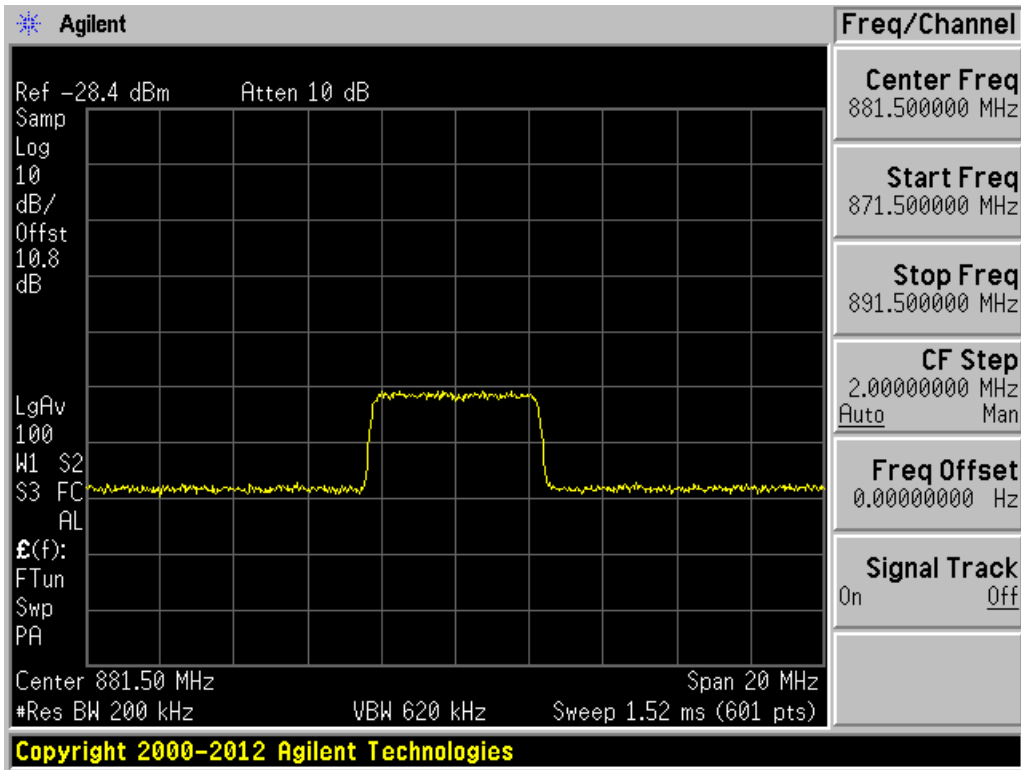
Downlink CDMA 881.5 MHz Output.



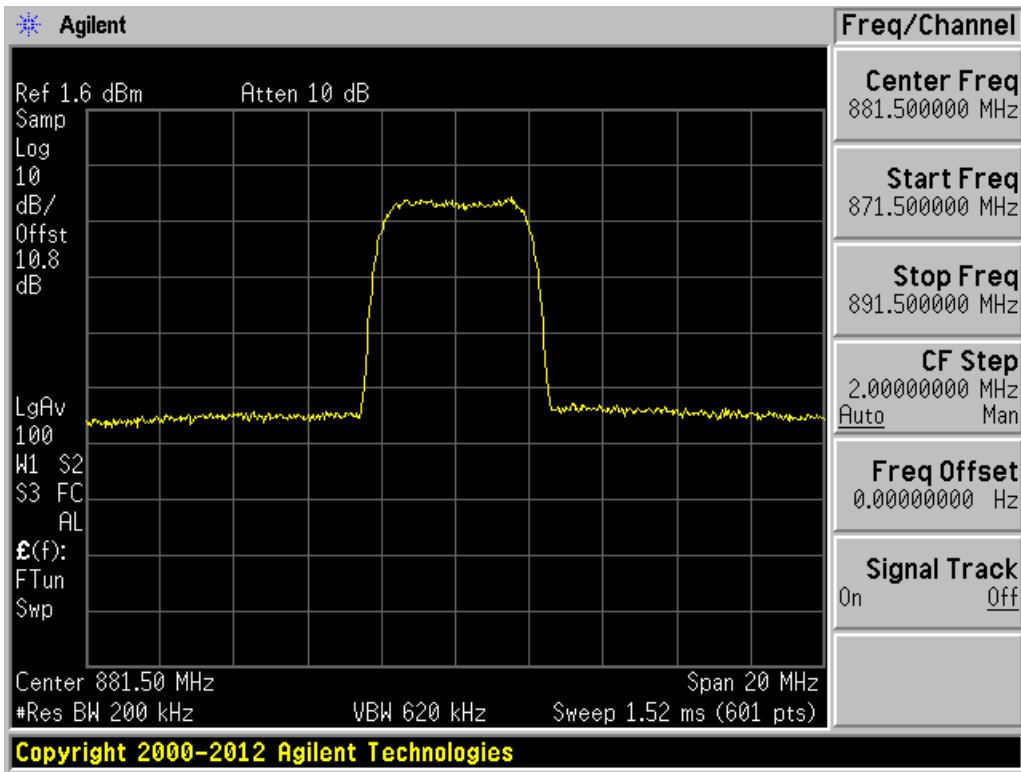
Downlink CDMA 881.5 MHz Input.



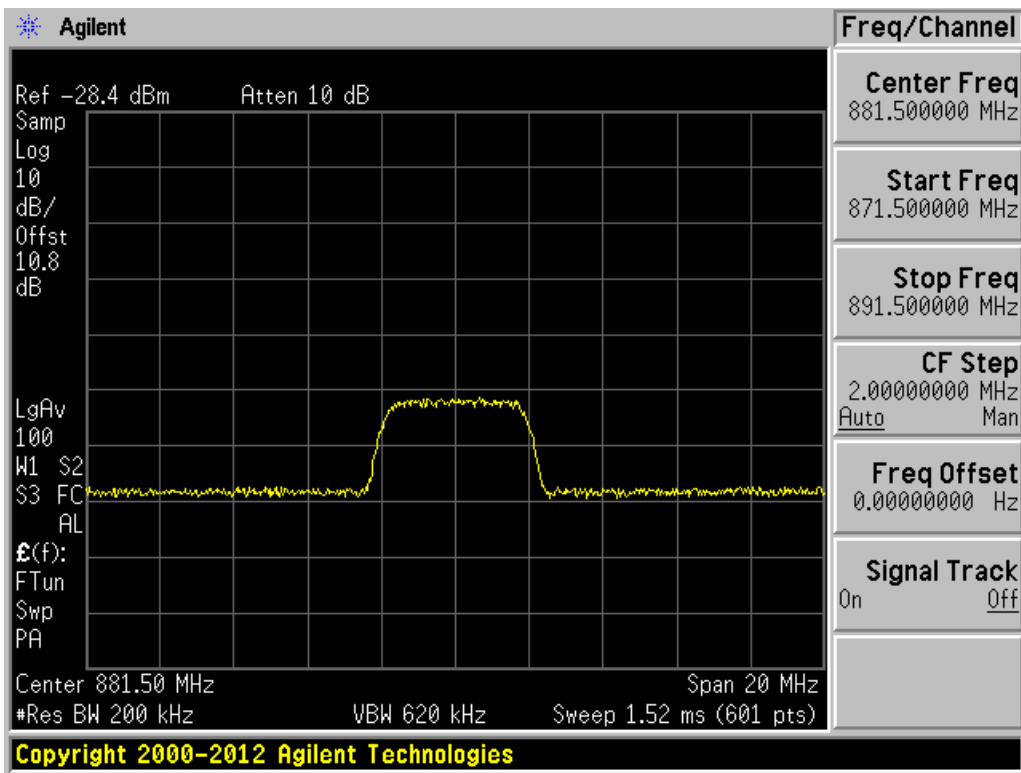
Downlink LTE 881.5 MHz Output.



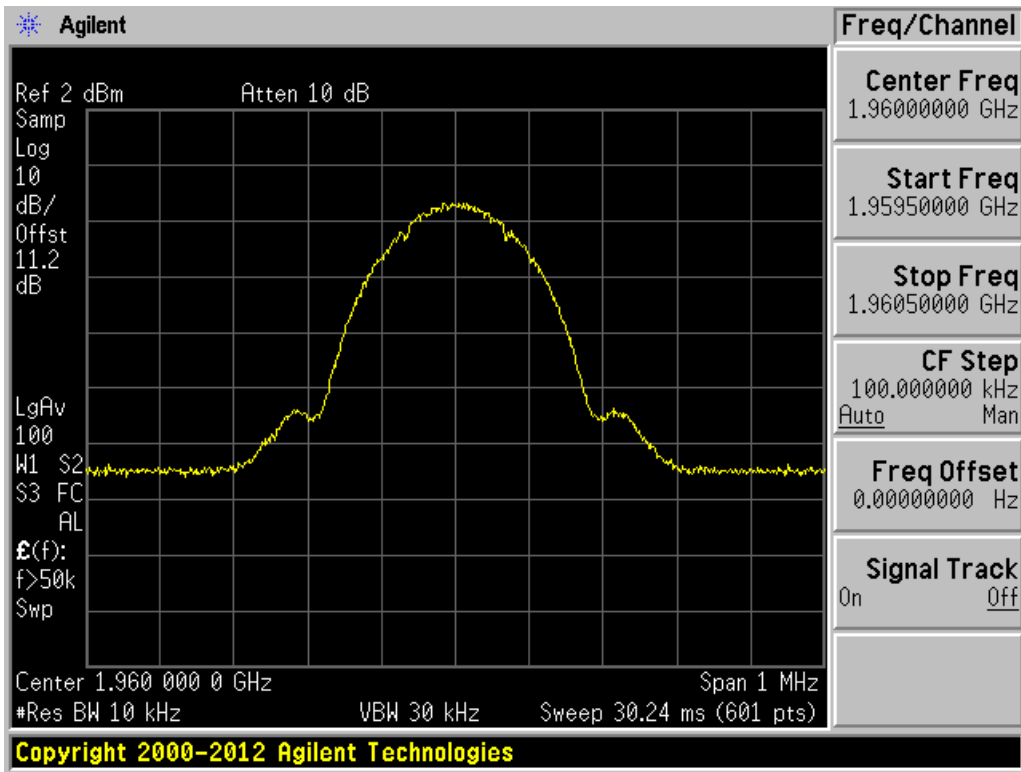
Downlink LTE 881.5 MHz Input.



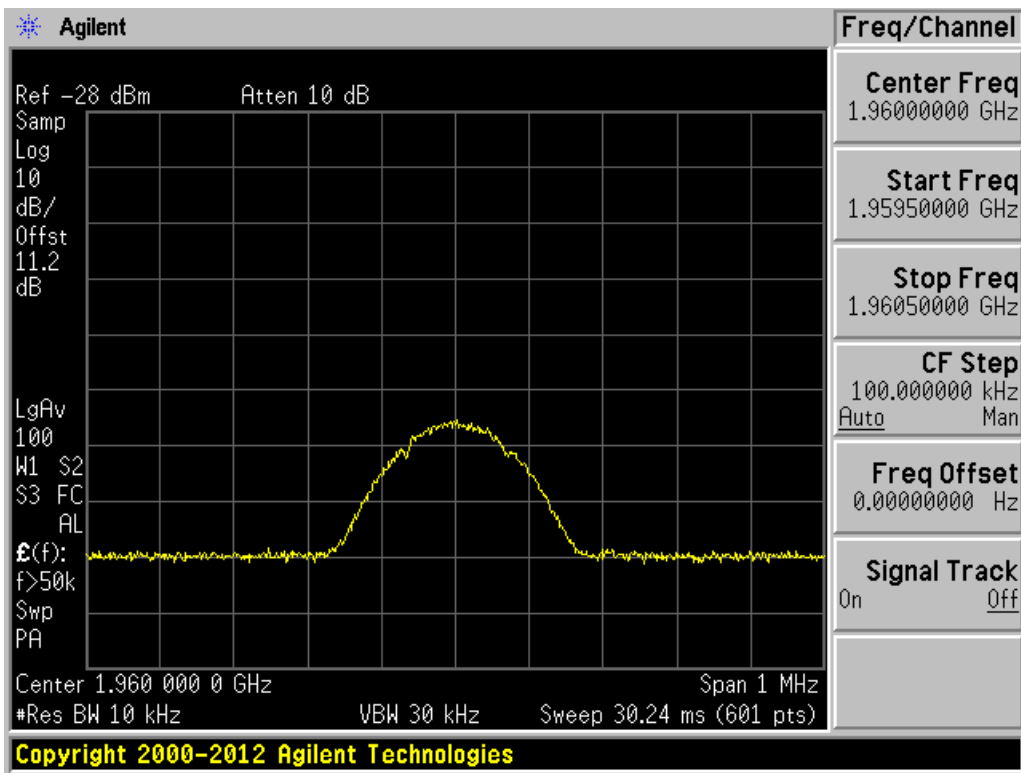
Downlink WCDMA 881.5 MHz Output.



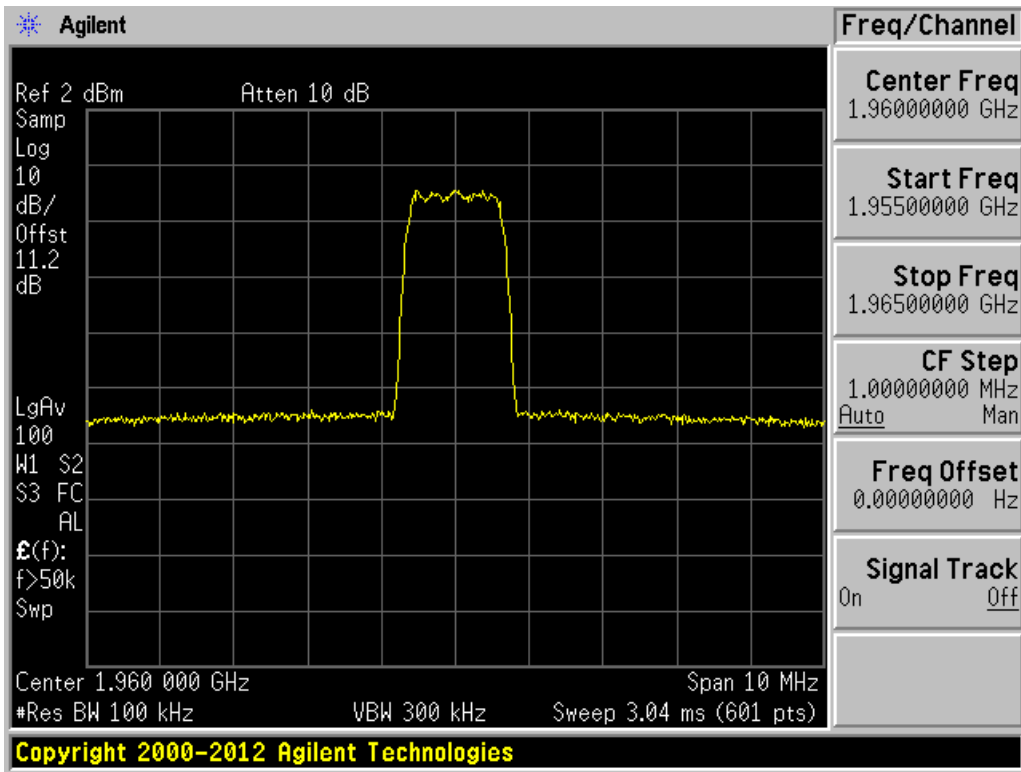
Downlink WCDMA 881.5 MHz Input.



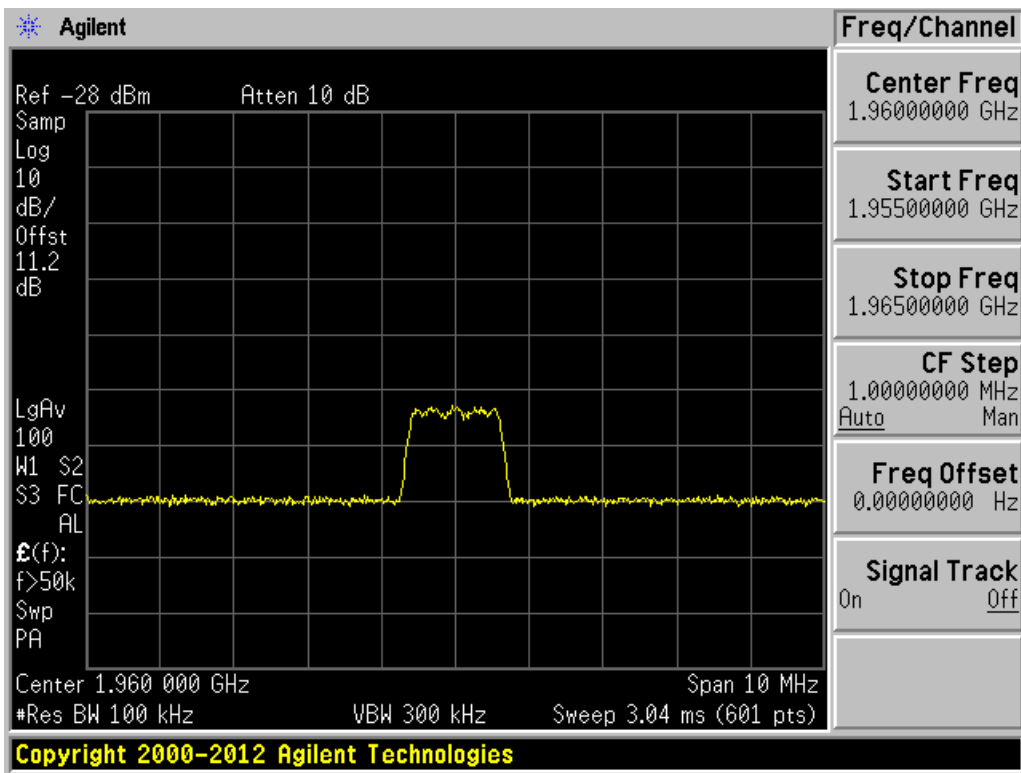
Downlink GSM 1960 MHz Output.



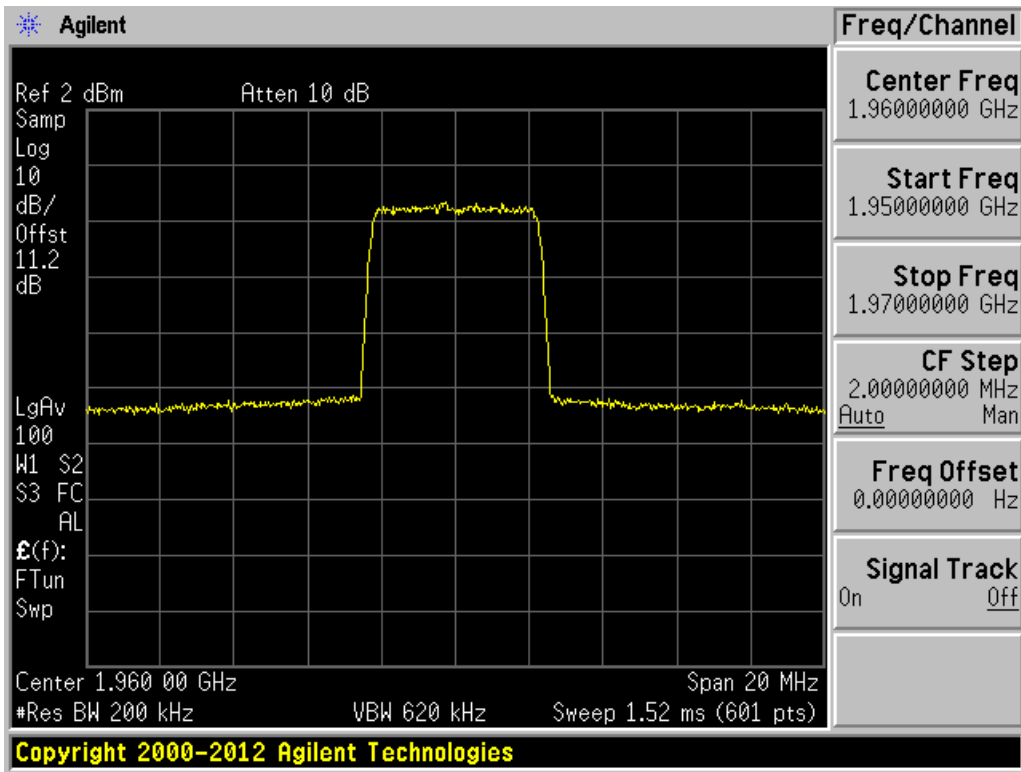
Downlink GSM 1960 MHz Input.



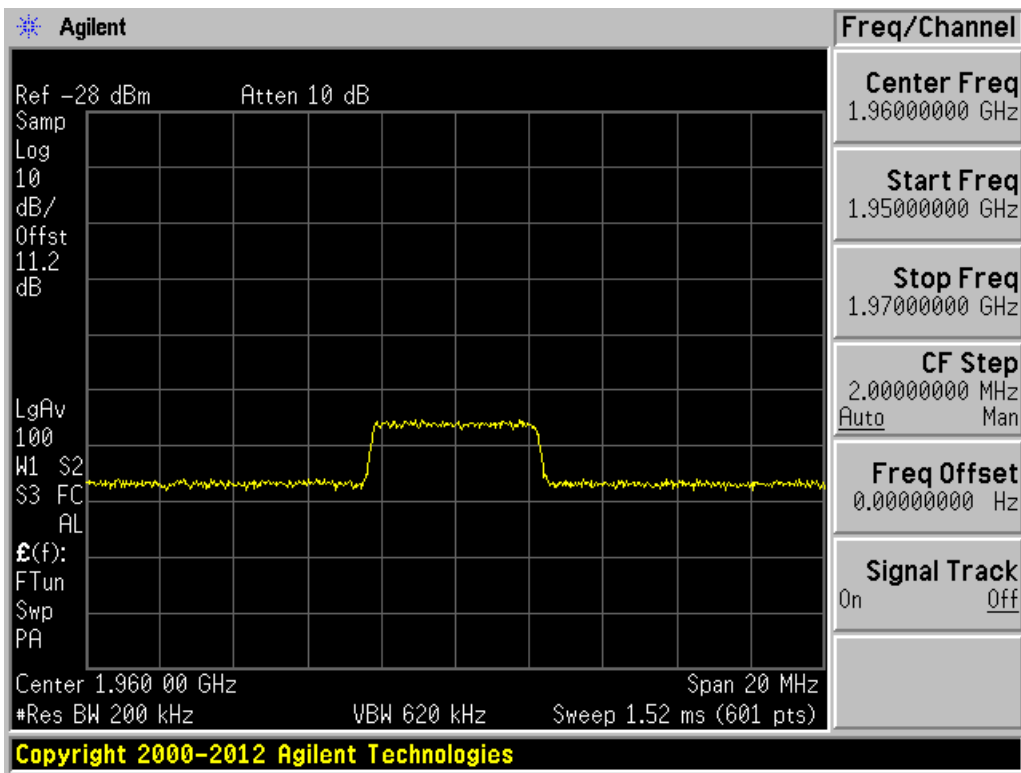
Downlink CDMA 1960 MHz Output.



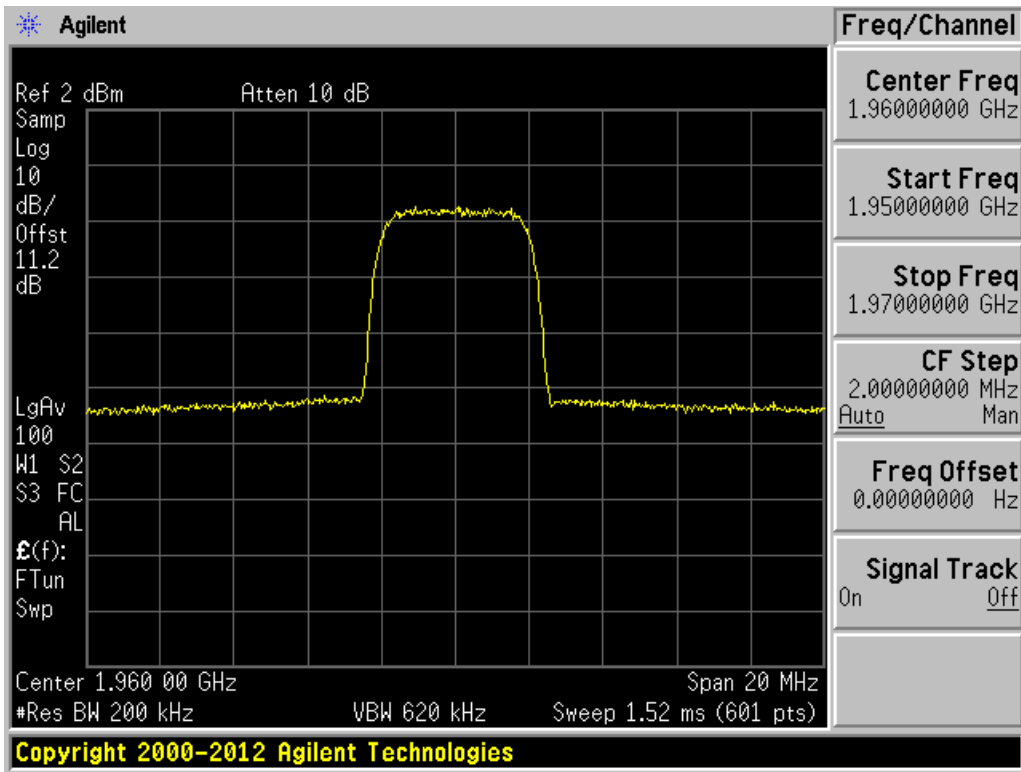
Downlink CDMA 1960 MHz Input.



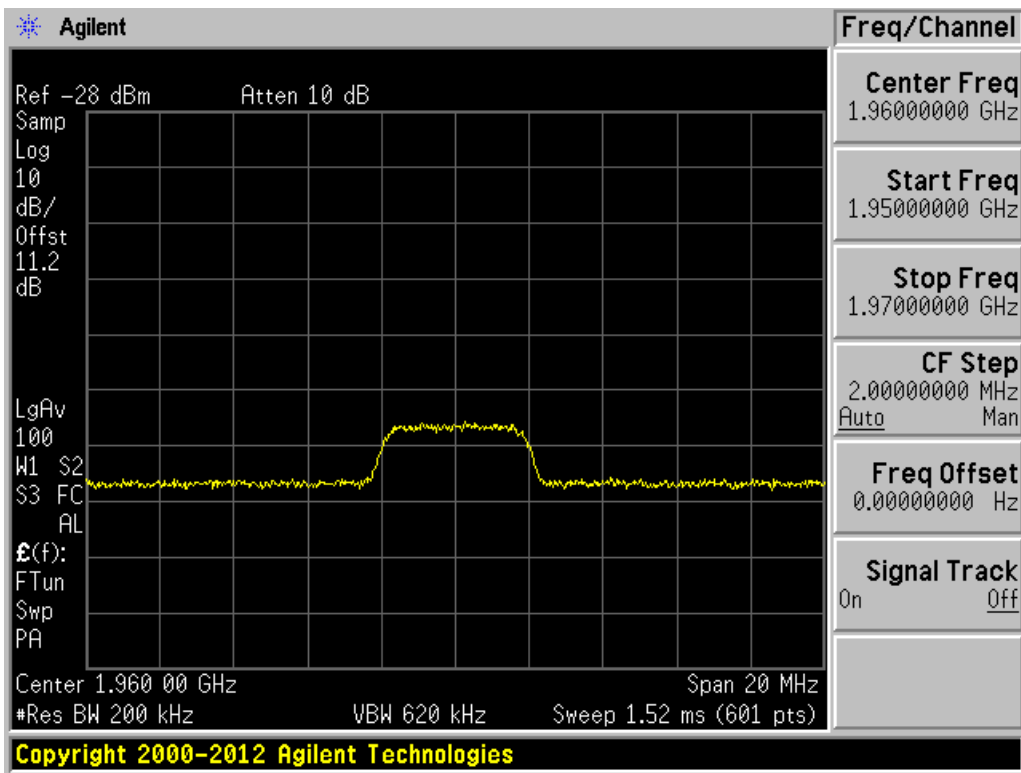
Downlink LTE 1960 MHz Output.



Downlink LTE 1960 MHz Input.



Downlink WCDMA 1960 MHz Output.



Downlink WCDMA 1960 MHz Input.

3.11 Oscillation Detection Test

(Reference: KDB #935210 D03, § 7.11)

Rule paragraph(s):

§ 20.21(e)(8)(ii)(A) *Anti-Oscillation. Consumer boosters must be able to detect and mitigate (i.e., by automatic gain reduction or shut down), any oscillations in uplink and downlink bands. Oscillation detection and mitigation must occur automatically within 0.3 seconds in the uplink band and within 1 second in the downlink band. In cases where oscillation is detected, the booster must continue mitigation for at least one minute before restarting. After five such restarts, the booster must not resume operation until manually reset.*

3.11.1 Anti-Oscillation test procedure

(In accordance with PBA inquiry #: 942758 alternative test procedure utilized to demonstrate compliance with oscillation detection requirement specified in Part 20.21(e)(8)(ii)(A))

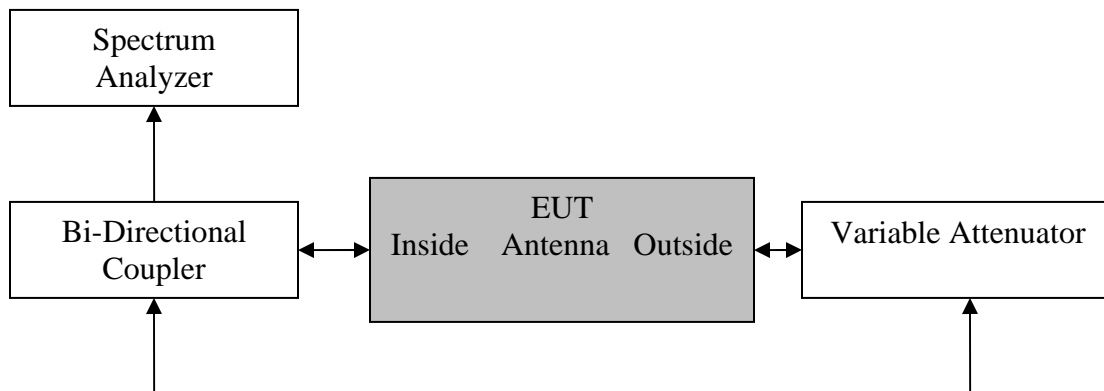
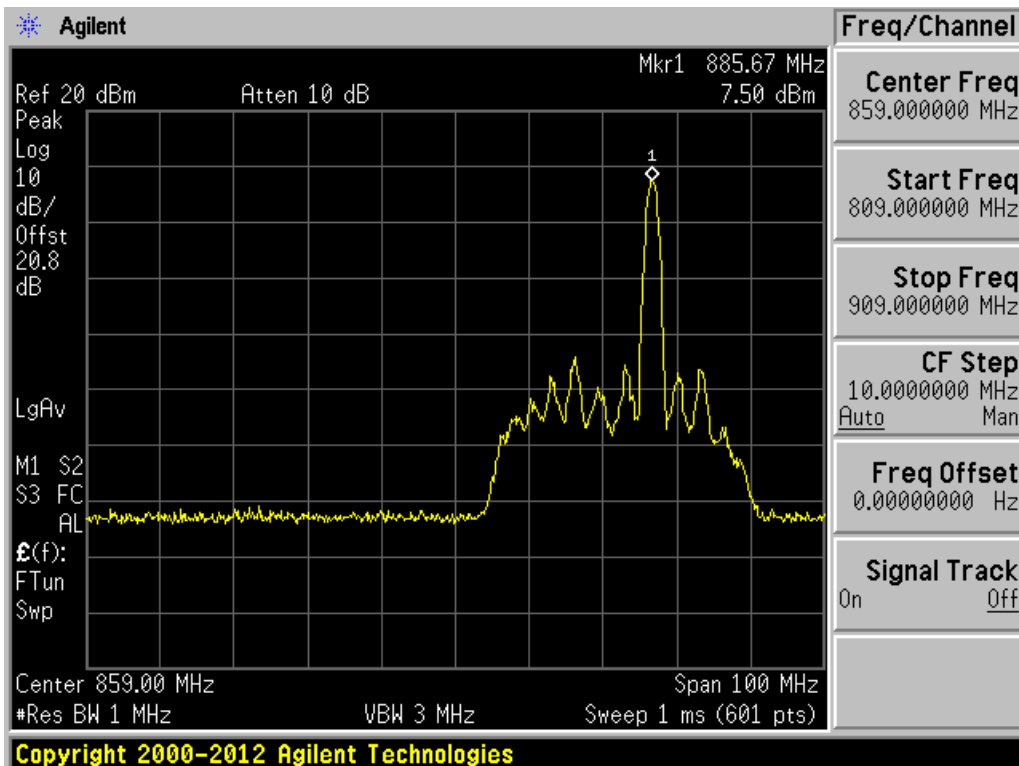


Figure 13

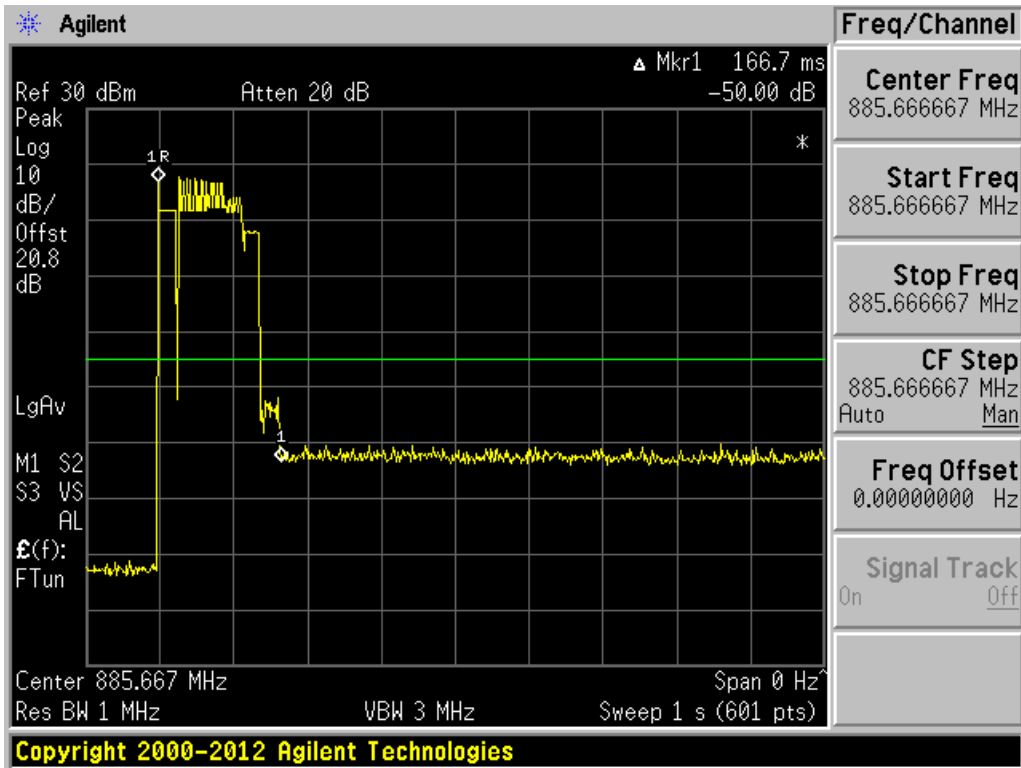
- A. Connect the EUT set for normal operation to the test equipment as shown in Figure 13. Note: bi-directional coupler allow path in both directions, uplink and downlink.
- B. Ensure that the RF coupled path is connected to the spectrum analyzer.
- C. Set the spectrum analyzer frequency to cover uplink and downlink bands of operation.
- D. Set RBW = 100 kHz.
- E. Set VBW \geq 300 kHz.
- F. Utilize the MAX HOLD function of the spectrum analyzer.
- G. Force the EUT to oscillate this will show frequency of oscillation.
- H. Capture the spectrum analyzer trace for inclusion in the test report.
- I. Set the spectrum analyzer centre frequency to frequency of oscillation determined in step G.
- J. Set the span of spectrum analyzer to 0 Hz.

- K. Set single sweep time to 1 s and set for a positive edge trigger and single trigger operation.
- L. Set the attenuation as necessary until the spectrum analyzer triggers and increase the attenuation level to a point 10 dB above that point.
- M. Reset the trigger of the spectrum analyzer and reset the EUT with a power cycle.
- N. Force the EUT to oscillate this will trigger the spectrum analyzer.
- O. Use the DELTA MARKER function of the spectrum analyzer to measure the time from the detection of oscillation until the EUT suppress the oscillation.
- P. Capture the spectrum analyzer trace for inclusion in the test report.
- Q. Set the spectrum analyzer sweep time for a minimum 120 seconds with an AUTO Trigger and a single sweep.
- R. Manually force the booster into oscillation. This will trigger sweep on spectrum analyzer. When the sweep is complete place cursors between the first two oscillation detections and save the plot for inclusion in the test report. The time between restarts must match the manufacturer's timing for the test mode and there can be no more than 5 restarts. (EUT set to test mode to decrease time between restarts to 12 seconds to show compliance with FCC requirements for maximum restarts permitted and timing between restarts in test mode)
- S. Repeat steps A to R for all operational bands.

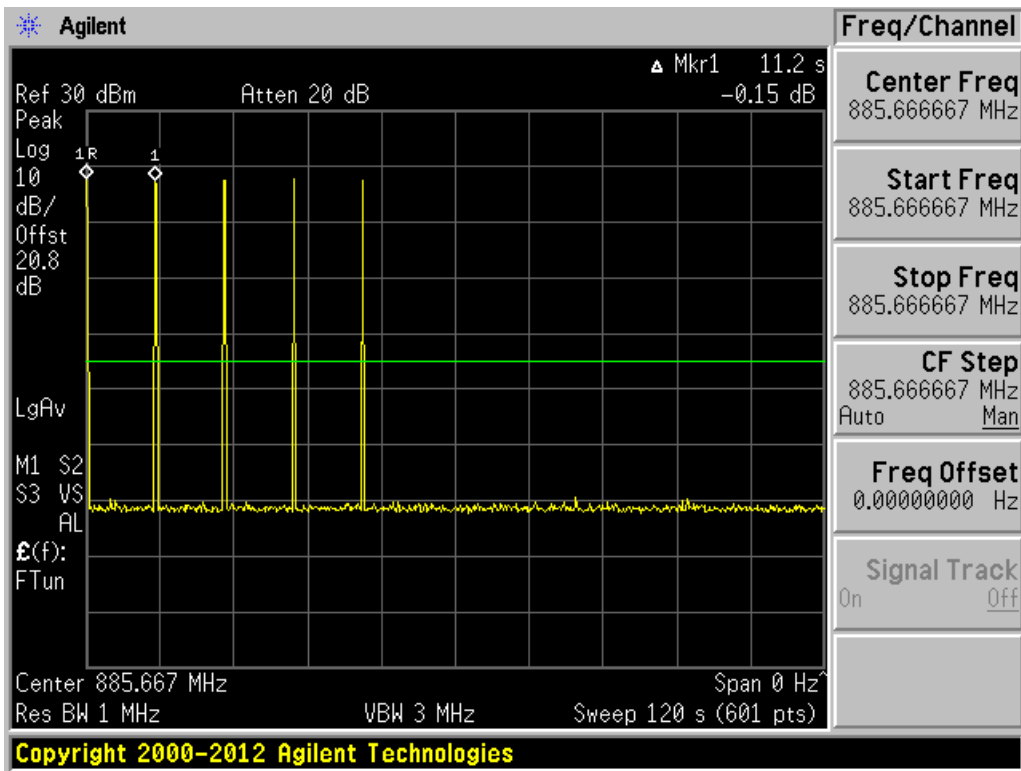
3.11.2 Test results



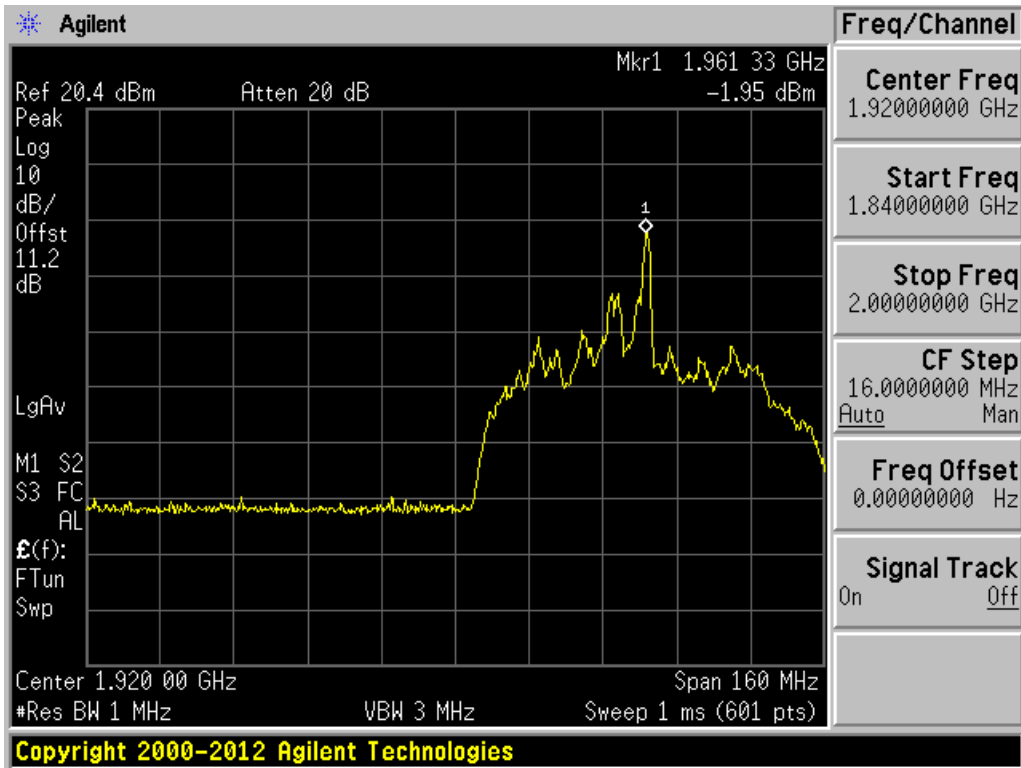
800 MHz band. Frequency of oscillation



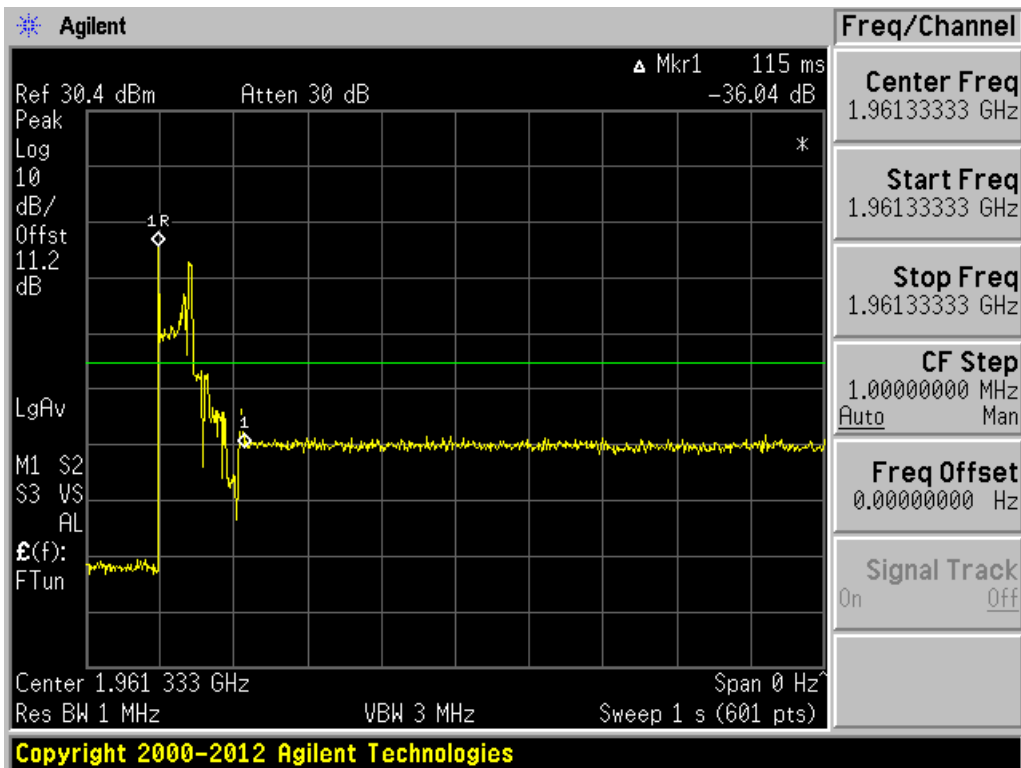
800 MHz band. Oscillation detection and control



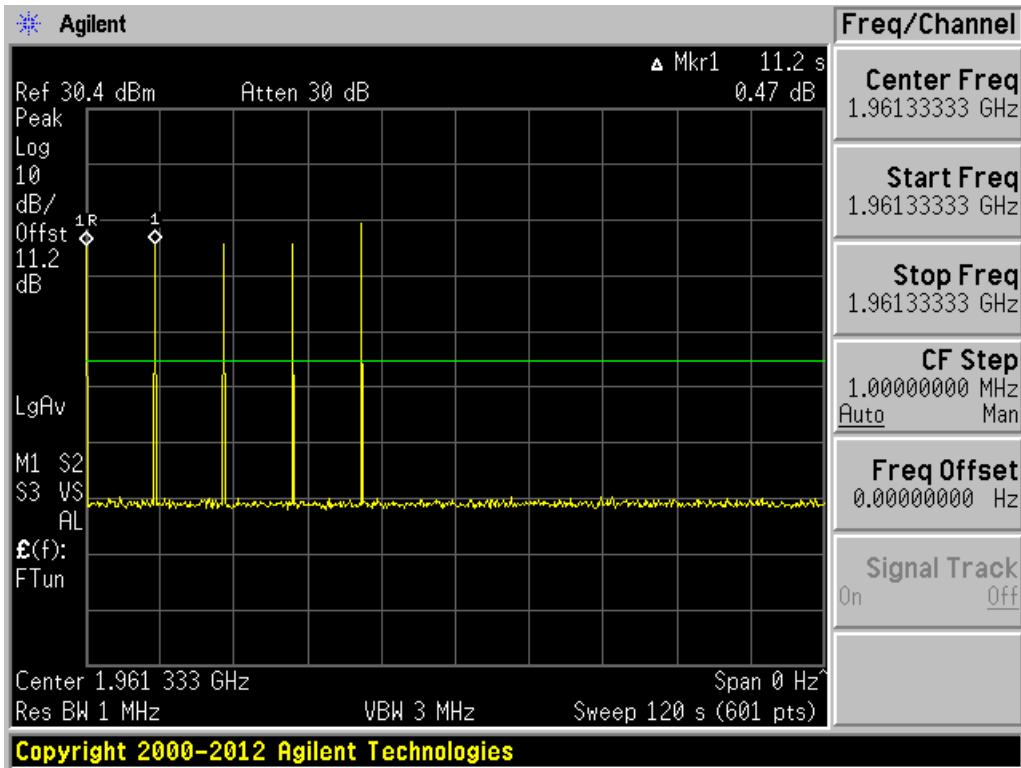
800 MHz band. 120 seconds sweep



1900 MHz band. Frequency of oscillation



1900 MHz band. Oscillation detection and control



1900 MHz band. 120 seconds sweep

3.12 Radiated Spurious Emissions Test.

(Reference: KDB #935210 D03, § 7.12)

Rule paragraph(s):

§ 2.1053 Field strength of spurious radiation.

3.12.1 Radiated spurious emissions test procedure

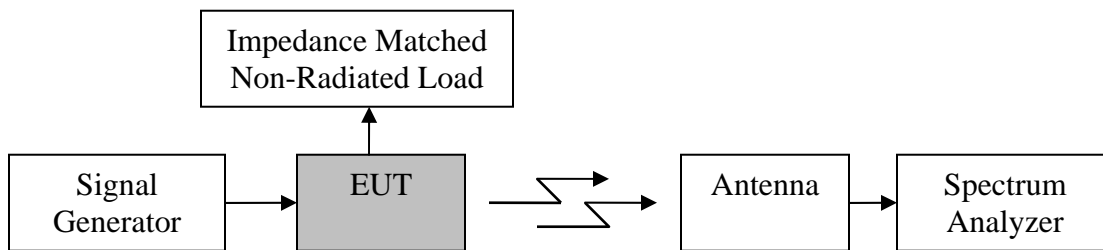


Figure 14

- A. Place the EUT on an OATS or Anechoic chamber turntable 3m from the receiving antenna.
- B. Connect the EUT to the test equipment as shown in Figure 14 beginning with the uplink output.
- C. Set the signal generator for the center frequency of the operational band under test with the power level set at (P in) from section 3.3.4 of this report with CW signal.
- D. Measure the radiated spurious emissions from the EUT from lowest to the highest frequencies as specified in §2.1057.
- E. Capture the peak emissions plots using a peak detector with Maximum Hold for inclusion in the test report. Tabular data is acceptable in lieu of spectrum analyzer plots.
- F. Repeat steps A to E for all operational bands.

3.12.2 Radiated spurious emissions test results.

These tests are provided on a separate document.

4 Booster Antenna Kitting.

All consumer boosters must be sold with user manuals specifying all antennas and cables that meet the requirements of this section. All consumer boosters must be sold together with antennas, cables, and/or coupling devices that meet the requirements of this section. The grantee is required to submit a technical document with the application for FCC equipment authorization that shows compliance of all antennas, cables and / or coupling devices with the requirements of this section, including any antenna or equipment upgrade options that may be available at initial purchase or as a subsequent upgrade.

Extension Cables

Cable Part #	Description	Cable	Minimum Cable loss (dB)
SEMRCBXmaXfe10	extension cable	10 ft. SEMRC205	-1.0
SEMRCBXmaXfe20	extension cable	20 ft. SEMRC 205	-2.0
SEMRCBXmaXfe30	extension cable	30 ft. SEMRC205	-3.0
SEMRCBXmaXfe40	extension cable	40 ft. SEMRC205	-4.0
SEMRCBXmaXfe50	extension cable	50 ft. SEMRC205	-5.0
SEMRCBXmaXfe60	extension cable	60 ft. SEMRC205	-6.0
SEMRCBLXmaXfe10	extension cable	10 ft. LMR400	-0.6
SEMRCBLXmaXfe20	extension cable	20 ft. LMR400	-1.2
SEMRCBLXmaXfe30	extension cable	30 ft. LMR400	-1.8
SEMRCBLXmaXfe40	extension cable	40 ft. LMR400	-2.4
SEMRCBLXmaXfe50	extension cable	50 ft. LMR400	-3.0
SEMRCBLXmaXfe60	extension cable	60 ft. LMR400	-3.6
SEMRCBLXmaXfe70	extension cable	70 ft. LMR400	-4.2
SEMRCBLXmaXfe80	extension cable	80 ft. LMR400	-4.8
SEMRCBLXmaXfe90	extension cable	90 ft. LMR400	-5.4
SEMRCBLXmaXfe100	extension cable	100 ft. LMR400	-6.0

2-Way power divider/splitter

Part #	Description	Insertion loss (dB)	Net gain (dB)
ADCSP1	2-way power divider	-3.0	-3.0
ADCSP3	3-way power divider	-3.0	-3.0

Inside Antennas

Antenna Part #	Description	Cable	Minimum Cable loss (dB)	Maximum Antenna Gain (dBi)	Net gain (dBi)
SEMD1XL	Inside antenna	18 ft. SEMRC205	-2.0	8.14	6.14
SEMOXL	Inside antenna	18 ft. SEMRC205	-2.0	0.0	-2.14
SEMOX	Inside antenna	10 ft. SEMRC105	-2.0	0.0	-2.14
SEMR1	Inside antenna	Direct to booster	0.0	0.0	2.14

Outside Antennas

Antenna Part #	Description	Cable	Minimum Cable loss (dB)	Maximum Antenna Gain (dBi)	Net gain (dBi)
SEMD1XL	Outside antenna	18 ft. SEMRC205	-2.0	8.14	6.14
SEMDA2XL	Outside antenna	18 ft. SEMRC205	-2.0	9.14	7.14
SEMOXL	Outside antenna	18 ft. SEMRC205	-2.0	0.0	-2.14
SEM2THX	Outside antenna	14 ft. SEMRC205	-1.5	2.14	0.64
SEM11THX	Outside antenna	14 ft. SEMRC205	-1.5	5.14	3.64
SEM14THX	Outside antenna	14 ft. SEMRC205	-1.5	5.14	3.64
SEM26THX	Outside antenna	14 ft. SEMRC205	-1.5	7.14	5.64
SEM2THXL	Outside antenna	25 ft. SEMRC205	-2.75	2.14	-0.61
SEM11THXL	Outside antenna	25 ft. SEMRC205	-2.75	5.14	2.39
SEM14THXL	Outside antenna	25 ft. SEMRC205	-2.75	5.14	2.39
SEM26THXL	Outside antenna	25 ft. SEMRC205	-2.75	7.14	4.39

5 MSCL Calculations & Measurements

Test Methodology:

MSCL was calculated using free air loss calculation at a distance of 2 meters and a polarity mismatch of 45 degrees between the CMRS and the booster server antenna.

Uplink Center Freq. (MHz)	836.5	1880
Free Air Loss	36.9	43.6
Polarity loss	2.7	2.7
Maximum net antenna gain including cable loss	6.1	4.1
MSCL (dB)	33.5	42.3