



FCC Test Report

FCC ID:S4R-TBWP

Product : Tablet PC

Trade Name : Smoothtalker

Model Number : TBWP

Serial Model : TBW8P,TBW16P,TBW32P

Report No. : NTEK-2015NT06031909F1

Prepared for

Mobile Communications Inc.

230 Earl Stewart Drive, Aurora, Ontario L4G 6V8, Canada

Prepared by

Shenzhen NTEK Testing Technology Co., Ltd.

1/F, Building E, Fenda Science Park, Sanwei Community, Xixiang Street,
Bao'an District, Shenzhen P.R. China

Tel.: +86-0755-61156588 Fax.: +86-0755-61156599

Website: www.ntek.org.cn

TEST RESULT CERTIFICATION

Applicant's name : Mobile Communications Inc.

Address : 230 Earl Stewart Drive, Aurora, Ontario L4G 6V8, Canada

Manufacturer's Name : Mobile Communications Inc.

Address : 230 Earl Stewart Drive, Aurora, Ontario L4G 6V8, Canada

Product description

Product name : Tablet PC

Model and/or type reference : TBWP

Serial Model : TBW8P,TBW16P,TBW32P

FCC Part15B:01 Oct.2014

Standards : ANSI C63.4:2014

This device described above has been tested by NTEK, and the test results show that the equipment under test (EUT) is in compliance with Part 15 of FCC Rules. And it is applicable only to the tested sample identified in the report.

This report shall not be reproduced except in full, without the written approval of NTEK, this document may be altered or revised by NTEK, personnel only, and shall be noted in the revision of the document.

Date of Test :

Date (s) of performance of tests : 03 Jun. 2015~24 Jun. 2015

Date of Issue..... : 24 Jun. 2015

Test Result..... : **Pass**

Testing Engineer : Jason Chen
(Jason Chen)

Technical Manager : Brown Lu
(Brown Lu)

Authorized Signatory : Bill Yao
(Bill Yao)

Table of Contents	Page
1 . TEST SUMMARY	4
1.1 TEST FACILITY	5
1.2 MEASUREMENT UNCERTAINTY	5
2 . GENERAL INFORMATION	6
2.1 GENERAL DESCRIPTION OF EUT	6
2.2 DESCRIPTION OF TEST SETUP	8
2.3 DESCRIPTION TEST PERIPHERAL AND EUT PERIPHERAL	9
2.4 MEASUREMENT INSTRUMENTS LIST	10
3 . EMC EMISSION TEST	11
3.1 CONDUCTED EMISSION MEASUREMENT	11
3.1.1 POWER LINE CONDUCTED EMISSION	11
3.1.2 TEST PROCEDURE	12
3.1.3 TEST SETUP	12
3.1.4 EUT OPERATING CONDITIONS	12
3.1.5 TEST RESULTS	13
3.2 RADIATED EMISSION MEASUREMENT	21
3.2.1 LIMITS OF RADIATED EMISSION MEASUREMENT	21
3.2.2 TEST PROCEDURE	21
3.2.3 TEST SETUP	22
3.2.4 EUT OPERATING CONDITIONS	23
3.2.5 TEST RESULTS	24
3.2.6 TEST RESULTS(1000~12400MHz)	26
4 . EUT TEST PHOTO	27

1. TEST SUMMARY

Test procedures according to the technical standards:

EMC Emission				
Standard	Test Item	Limit	Judgment	Remark
FCC Part15B:2014 ANSI C63.4: 2014	Conducted Emission	Class B	PASS	
	Radiated Emission	Class B	PASS	

NOTE:

- (1) 'N/A' denotes test is not applicable in this Test Report
- (2) For client's request and manual description, the test will not be executed.

1.1 TEST FACILITY

NTEK Testing Technology Co., Ltd

Add. : 1/F, Building E, Fenda Science Park, Sanwei Community, Xixiang Street, Bao'an District, Shenzhen P.R. China.

FCC Registration Number:238937; IC Registration Number:9270A-1

CNAS Registration Number:L5516

1.2 MEASUREMENT UNCERTAINTY

The reported uncertainty of measurement $y \pm U$, where expanded uncertainty U is based on a standard uncertainty multiplied by a coverage factor of $k=2$, providing a level of confidence of approximately **95** %.

A. Conducted Measurement :

Test Site	Method	Measurement Frequency Range	U , (dB)	NOTE
NTEKC01	ANSI	150 KHz ~ 30MHz	3.2	

B. Radiated Measurement :

Test Site	Method	Measurement Frequency Range	U , (dB)	NOTE
NTEKA01	ANSI	30MHz ~ 1000MHz	4.7	
		1GHz ~12.4GHz	5.0	

2. GENERAL INFORMATION

2.1 GENERAL DESCRIPTION OF EUT

Equipment	Tablet PC	
Model Name	TBWP	
Additional Model Number(s)	TBW8P,TBW16P,TBW32P	
Model Difference	All the model are the same circuit and RF module, except the model name and colour.	
Product Description	The EUT is a Tablet PC.	
	Connecting I/O port:	DC in,USB
	Operation Frequency:	BT:2402~2480 MHz WIFI: 802.11b/g/n(20MHz): 2412~2462MHz 802.11n(40MHz):2422~2452MHz
	Modulation Type:	BT(1Mbps)/4.0: GFSK BT EDR(2Mbps): $\pi/4$ -DQPSK BT EDR(3Mbps): 8-DPSK IEEE 802.11b : DSSS (CCK, QPSK, DBPSK) IEEE 802.11g/n (HT20/HT40) : OFDM(64QAM, 16QAM, QPSK, BPSK)
Power Source	AC Voltage	
Adapter	Mode : JK050200-S04USB Input: 100-240V~, 50/60Hz, 0.5A Output: 5V $\overline{\text{---}}$, 2000mA	
Battery	DC 3.7V, 5000mAh	

2.1.1 DESCRIPTION OF TEST MODES

To investigate the maximum EMI emission characteristics generates from EUT, the test system was pre-scanning tested base on the consideration of following EUT operation mode or test configuration mode which possible have effect on EMI emission level. Each of these EUT operation mode(s) or test configuration mode(s) mentioned above was evaluated respectively.

Pretest Mode	Description
Mode 1	Data Exchange Mode
Mode 2	REC Mode
Mode 3	TF Card Playing Mode+Charging

For Conducted Test	
Final Test Mode	Description
Mode 1	Data Exchange Mode

For Radiated Test	
Final Test Mode	Description
Mode 1	Data Exchange Mode

Note: Final Test Mode: Through Pre-scan, find the mode 1 is the worse case. Only the worst case mode is recorded in the report.

2.2 DESCRIPTION OF TEST SETUP

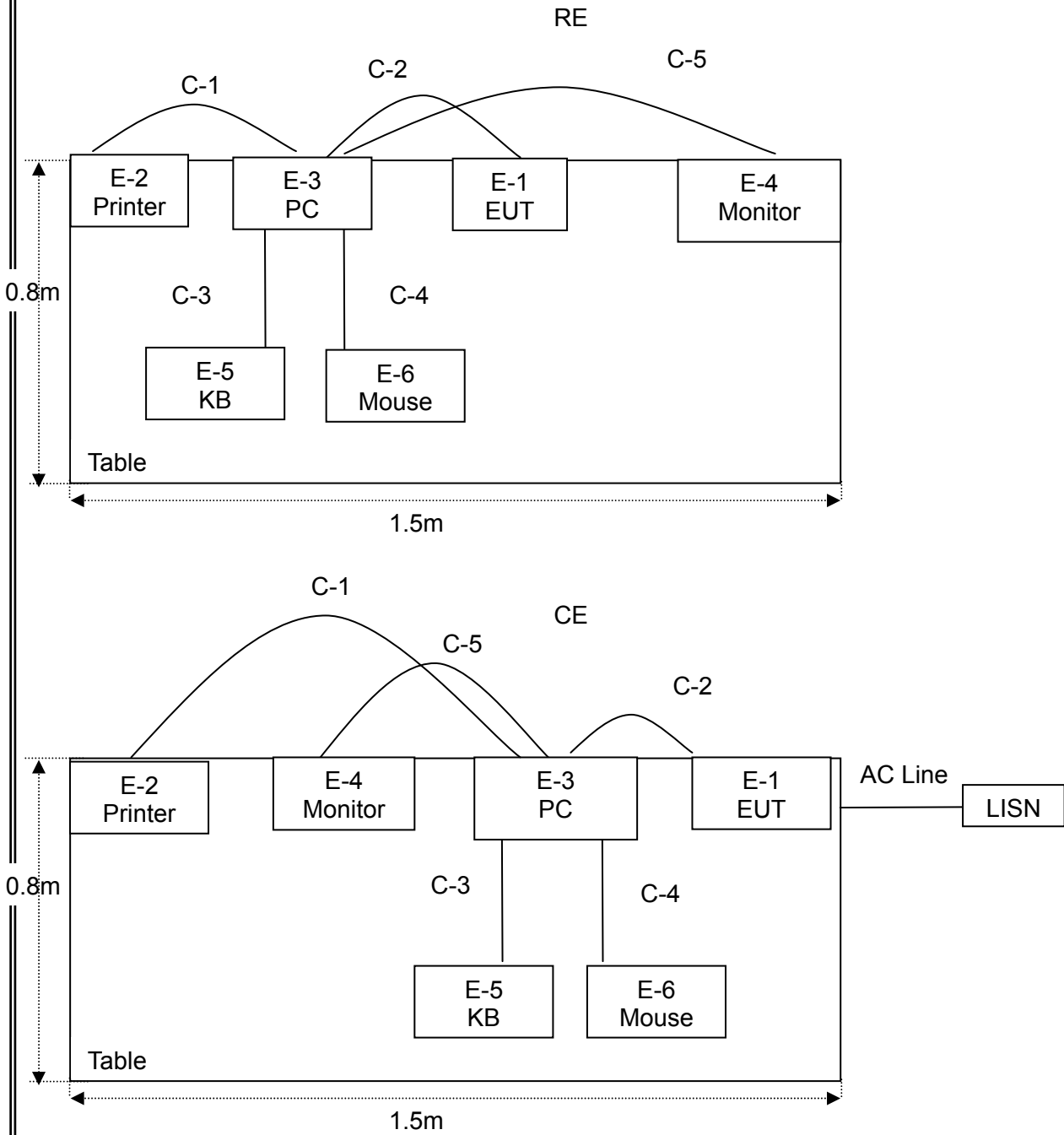

2.3 DESCRIPTION TEST PERIPHERAL AND EUT PERIPHERAL

The EUT has been tested as an independent unit together with other necessary accessories or support units. The following support units or accessories were used to form a representative test configuration during the tests.

Item	Equipment	Brand	Model/Type No.	Series No.	Note
E-1	Tablet PC	Smoothtalker	TBWP	N/A	EUT
E-2	Printer	Canon	L11121E	LBP2900	
E-3	Personal computer	DELL	FT4Y23X	34413561645	
E-4	Monitor	DELL	IN2020MB	cn-0y6mhx-74261-11f-67es	
E-5	Keyboard	DELL	SK-8185	OY526KUS	
E-6	Mouse	DELL	MS111-P	cn-011d3v-71581-11e-1th7	

Item	Shielded Type	Ferrite Core	Length	Note
C-1	NO	NO	1.2m	
C-2	NO	NO	1.0m	
C-3	NO	NO	1.0m	
C-4	NO	NO	1.0m	
C-5	NO	NO	1.0m	

Note:

- (1) The support equipment was authorized by Declaration of Confirmation.
- (2) For detachable type I/O cable should be specified the length in cm in 『Length』 column.
- (3) “YES” means “shielded” “with core”; “NO” means “unshielded” “without core”.

2.4 MEASUREMENT INSTRUMENTS LIST

2.4.1 CONDUCTED TEST SITE

Item	Kind of Equipment	Manufacturer	Type No.	Serial No.	Last calibration	Calibrated until	Calibration period
1	LISN	R&S	ENV216	101313	Jul. 06, 2014	Jul. 05, 2015	1 year
2	LISN	SCHWARZBECK	NNLK 8129	8129245	Dec. 25, 2014	Dec. 24, 2015	1 year
3	Pulse Limiter	SCHWARZBECK	VTSD 9561F	9716	Dec. 25, 2014	Dec. 24, 2015	1 year
4	50Ω Switch	ANRITSU CORP	MP59B	6200983704	Jul. 06, 2014	Jul. 05, 2015	1 year
5	Test Cable	N/A	C01	N/A	Jul. 06, 2014	Jul. 05, 2015	1 year
6	Test Cable	N/A	C02	N/A	Jul. 06, 2014	Jul. 05, 2015	1 year
7	Test Cable	N/A	C03	N/A	Jul. 06, 2014	Jul. 05, 2015	1 year
8	EMI Test Receiver	R&S	ESCI	101160	Jul. 06, 2014	Jul. 05, 2015	1 year
9	Passive Voltage Probe	ESH2-Z3	R&S	100196	Jul. 06, 2014	Jul. 05, 2015	1 year
10	Absorbing Clamp	R&S	MDS-21	100423	Jul. 08, 2014	Jul. 07, 2015	1 year

2.4.2 RADIATED TEST SITE

Item	Kind of Equipment	Manufacturer	Type No.	Serial No.	Last calibration	Calibrated until	Calibration period
1	Bilog Antenna	TESEQ	CBL6111D	31216	Jul. 06, 2014	Jul. 05, 2015	1 year
2	Test Cable	N/A	R-01	N/A	Dec. 25, 2014	Dec. 24, 2015	1 year
3	Test Cable	N/A	R-02	N/A	Dec. 25, 2014	Dec. 24, 2015	1 year
4	EMI Test Receiver	R&S	ESCI-7	101318	Jul. 06, 2014	Jul. 05, 2015	1 year
5	Antenna Mast	EM	SC100_1	N/A	N/A	N/A	N/A
6	Turn Table	EM	SC100	060531	N/A	N/A	N/A
7	50Ω Switch	Anritsu Corp	MP59B	6200983705	Jul. 06, 2014	Jul. 05, 2015	1 year
8	Spectrum Analyzer	Aglient	E4407B	MY45108040	Jul. 06, 2014	Jul. 05, 2015	1 year
9	Horn Antenna	EM	EM-AH-10180	2011071402	Jul. 06, 2014	Jul. 05, 2015	1 year
10	Amplifier	EM	EM-30180	060538	Jul. 06, 2014	Jul. 05, 2015	1 year
11	Loop Antenna	ARA	PLA-1030/B	1029	Jul. 06, 2014	Jul. 05, 2015	1 year

3. EMC EMISSION TEST

3.1 CONDUCTED EMISSION MEASUREMENT

3.1.1 POWER LINE CONDUCTED EMISSION (Frequency Range 150KHz-30MHz)

FREQUENCY (MHz)	Class A (dBuV)		Class B (dBuV)	
	Quasi-peak	Average	Quasi-peak	Average
0.15 -0.5	79.00	66.00	66 - 56 *	56 - 46 *
0.50 -5.0	73.00	60.00	56.00	46.00
5.0 -30.0	73.00	60.00	60.00	50.00

Note:

- (1) The tighter limit applies at the band edges.
- (2) The limit of " * " marked band means the limitation decreases linearly with the logarithm of the frequency in the range.

The following table is the setting of the receiver

Receiver Parameters	Setting
Attenuation	10 dB
Start Frequency	0.15 MHz
Stop Frequency	30 MHz
IF Bandwidth	9 kHz

3.1.2 TEST PROCEDURE

- a. The EUT was placed 0.8 meters from the horizontal ground plane with EUT being connected to the power mains through a line impedance stabilization network (LISN). All other support equipments powered from additional LISN(s). The LISN provide 50 Ohm/ 50uH of coupling impedance for the measuring instrument.
- b. Interconnecting cables that hang closer than 40 cm to the ground plane shall be folded back and forth in the center forming a bundle 30 to 40 cm long.
- c. I/O cables that are not connected to a peripheral shall be bundled in the center. The end of the cable may be terminated, if required, using the correct terminating impedance. The overall length shall not exceed 1 m.
- d. LISN at least 80 cm from nearest part of EUT chassis.
- e. For the actual test configuration, please refer to the related Item –EUT Test Photos.

3.1.3 TEST SETUP

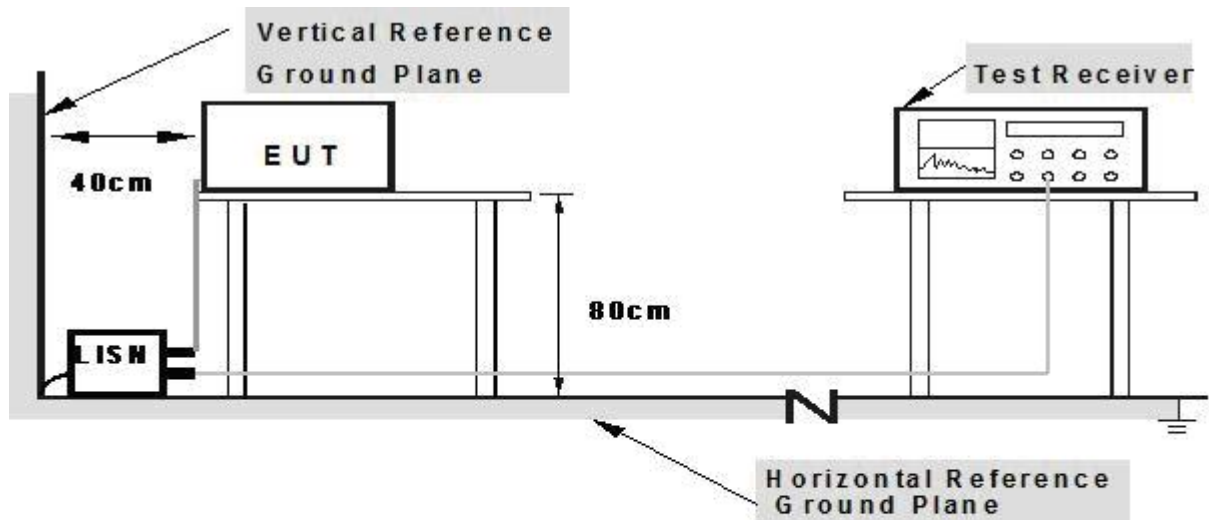

- Note: 1. Support units were connected to second LISN.**
2. Both of LISNs (AMN) are 80 cm from EUT and at least 80 from other units and other metal planes

3.1.4 EUT OPERATING CONDITIONS

The EUT tested system was configured as the statements of 2.3 Unless otherwise a special operating condition is specified in the follows during the testing.

3.1.5 TEST RESULTS

EUT :	Tablet PC	Model Name. :	TBWP
Temperature :	26 °C	Relative Humidity :	54%
Pressure :	1010hPa	Test Date :	2015-06-22
Test Mode :	Mode 1	Phase :	L
Test Voltage :	DC5V Form PC AC 120V/60Hz		

Frequency (MHz)	Reading Level (dBμV)	Correct Factor (dB)	Measure-ment (dBμV)	Limits (dBμV)	Margin (dB)	Remark
0.2140	46.14	0.00	46.14	63.04	-16.90	QP
0.2860	43.30	0.00	43.30	60.64	-17.34	QP
3.7620	48.65	0.00	48.65	56.00	-7.35	QP
11.7859	48.52	0.00	48.52	60.00	-11.48	QP
3.8340	42.66	0.00	42.66	46.00	-3.34	AVG
0.9940	37.28	0.00	37.28	46.00	-8.72	AVG
11.7179	39.44	0.00	39.44	50.00	-10.56	AVG

Remark:

1. All readings are Quasi-Peak and Average values.
2. Factor = Insertion Loss + Cable Loss.

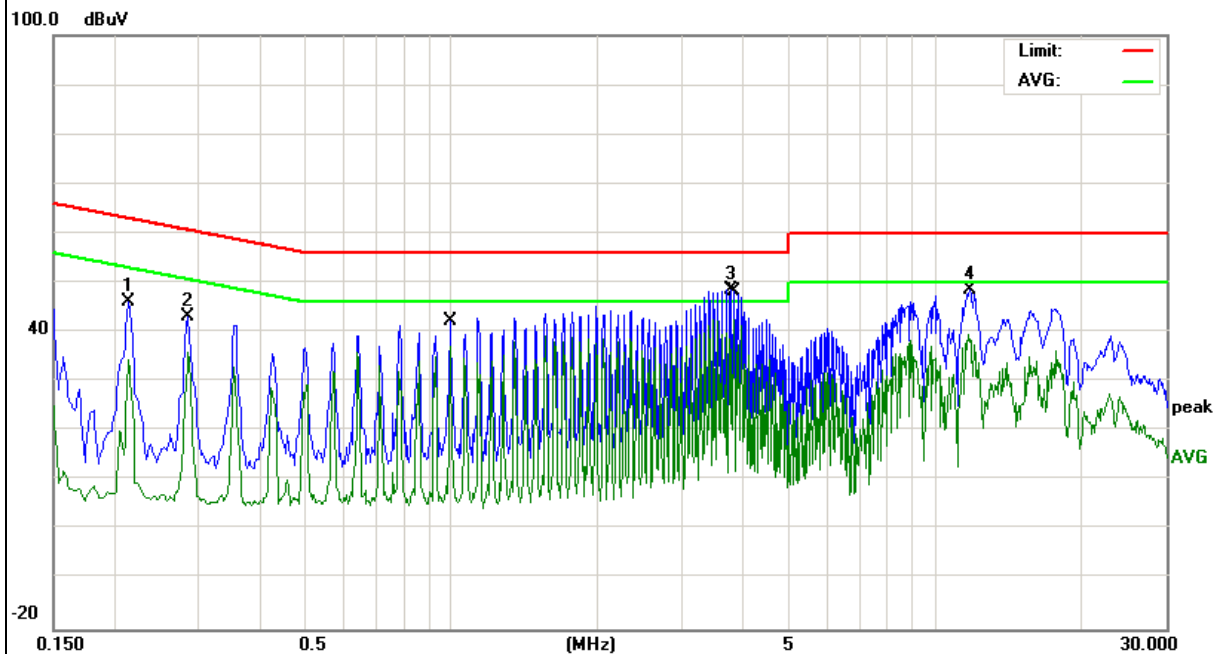

EUT :	Tablet PC	Model Name. :	TBWP
Temperature :	26 °C	Relative Humidity :	54%
Pressure :	1010hPa	Test Date :	2015-06-22
Test Mode :	Mode 1	Phase :	N
Test Voltage :	DC5V Form PC AC 120V/60Hz		

Frequency (MHz)	Reading Level (dBμV)	Correct Factor (dB)	Measure-ment (dBμV)	Limits (dBμV)	Margin (dB)	Remark
0.2140	36.34	9.62	45.96	63.04	-17.08	QP
0.2140	25.12	9.62	34.74	53.04	-18.30	AVG
0.2860	34.53	9.61	44.14	60.64	-16.50	QP
3.7020	25.85	9.52	35.37	46.00	-10.63	AVG
3.9180	33.84	9.51	43.35	56.00	-12.65	QP
17.6739	38.25	9.80	48.05	60.00	-11.95	QP
17.6739	27.06	9.80	36.86	50.00	-13.14	AVG

Remark:

1. All readings are Quasi-Peak and Average values.
2. Factor = Insertion Loss + Cable Loss.

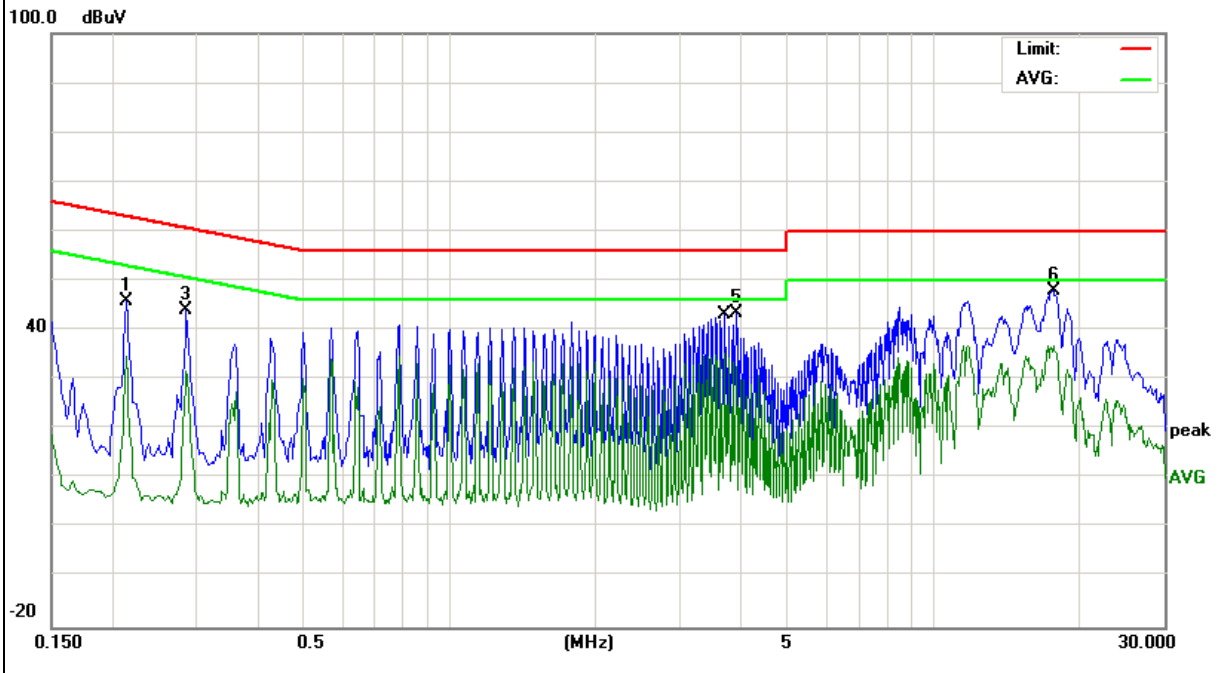

EUT :	Tablet PC	Model Name. :	TBWP
Temperature :	26 °C	Relative Humidity :	54%
Pressure :	1010hPa	Test Date :	2015-06-22
Test Mode :	Mode 1	Phase :	L
Test Voltage :	DC5V Form PC AC 240V/60Hz		

Frequency (MHz)	Reading Level (dBμV)	Correct Factor (dB)	Measure-ment (dBμV)	Limits (dBμV)	Margin (dB)	Remark
0.2100	38.90	9.61	48.51	63.20	-14.69	QP
0.2100	23.98	9.61	33.59	53.20	-19.61	AVG
0.7700	34.88	9.77	44.65	56.00	-11.35	QP
0.7700	27.50	9.77	37.27	46.00	-8.73	AVG
3.6300	36.73	9.69	46.42	56.00	-9.58	QP
3.7020	29.19	9.69	38.88	46.00	-7.12	AVG
11.4579	28.54	9.75	38.29	50.00	-11.71	AVG
11.5979	37.42	9.75	47.17	60.00	-12.83	QP

Remark:

1. All readings are Quasi-Peak and Average values.
2. Factor = Insertion Loss + Cable Loss.

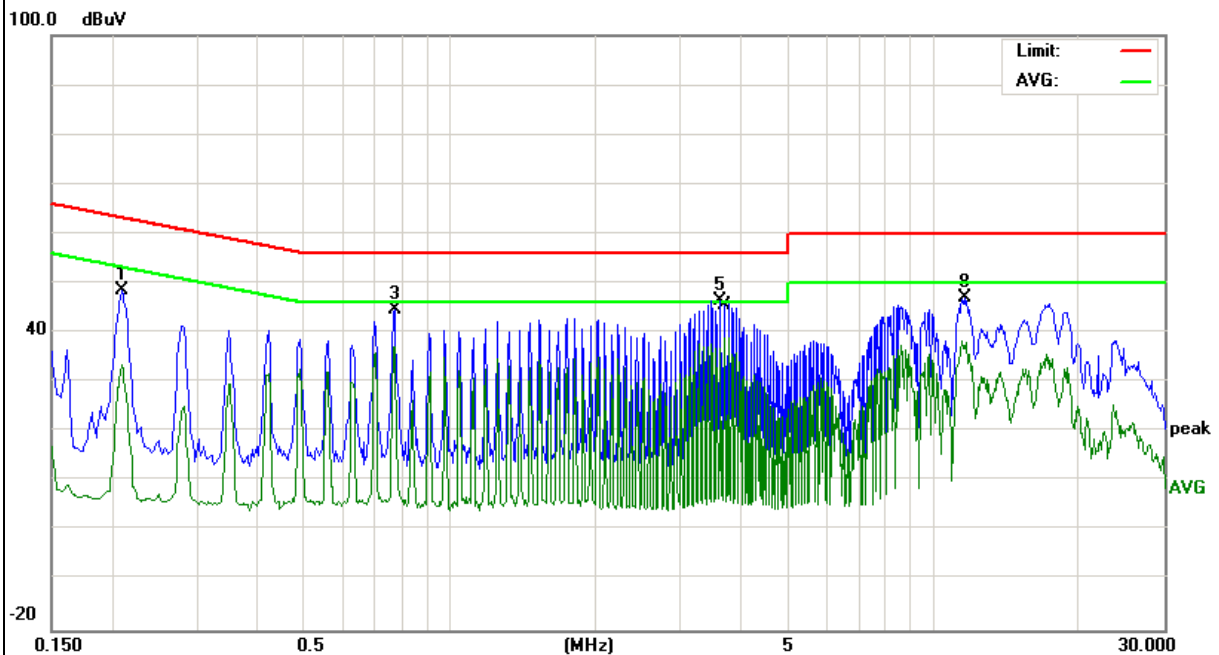

EUT :	Tablet PC	Model Name. :	TBWP
Temperature :	26 °C	Relative Humidity :	54%
Pressure :	1010hPa	Test Date :	2015-06-22
Test Mode :	Mode 1	Phase :	N
Test Voltage :	DC5V Form PC AC 240V/60Hz		

Frequency (MHz)	Reading Level (dBμV)	Correct Factor (dB)	Measure-ment (dBμV)	Limits (dBμV)	Margin (dB)	Remark
0.2100	39.05	9.61	48.66	63.20	-14.54	QP
0.2100	21.25	9.61	30.86	53.20	-22.34	AVG
0.4900	29.38	9.73	39.11	56.17	-17.06	QP
0.7660	29.84	9.77	39.61	56.00	-16.39	QP
0.7660	22.85	9.77	32.62	46.00	-13.38	AVG
3.5460	21.51	9.69	31.20	46.00	-14.80	AVG
3.8260	30.35	9.70	40.05	56.00	-15.95	QP
8.4220	29.22	9.70	38.92	60.00	-21.08	QP
8.4220	19.81	9.70	29.51	50.00	-20.49	AVG

Remark:

1. All readings are Quasi-Peak and Average values.
2. Factor = Insertion Loss + Cable Loss.

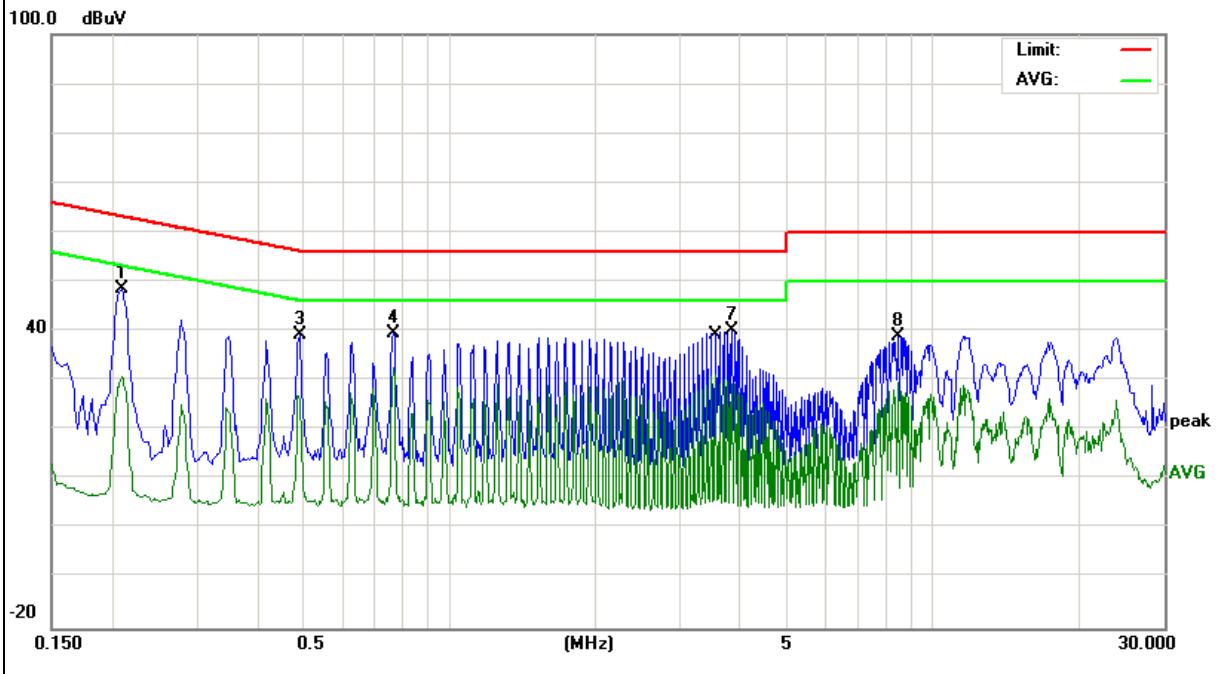

EUT :	Tablet PC	Model Name. :	TBWP
Temperature :	26 °C	Relative Humidity :	54%
Pressure :	1010hPa	Test Date :	2015-06-22
Test Mode :	Mode 1	Phase :	L
Test Voltage :	DC5V Form Adapter AC 120V/60Hz		

Frequency (MHz)	Reading Level (dBμV)	Correct Factor (dB)	Measure-ment (dBμV)	Limits (dBμV)	Margin (dB)	Remark
0.7060	34.41	9.78	44.19	56.00	-11.81	QP
0.7060	30.81	9.78	40.59	46.00	-5.41	AVG
0.3899	36.76	9.40	46.16	58.06	-11.90	QP
1.5500	32.67	9.68	42.35	56.00	-13.65	QP
0.4260	34.19	9.46	43.65	47.33	-3.68	AVG
0.7060	30.81	9.78	40.59	46.00	-5.41	AVG
1.5500	27.69	9.68	37.37	46.00	-8.63	AVG

Remark:

1. All readings are Quasi-Peak and Average values.
2. Factor = Insertion Loss + Cable Loss.

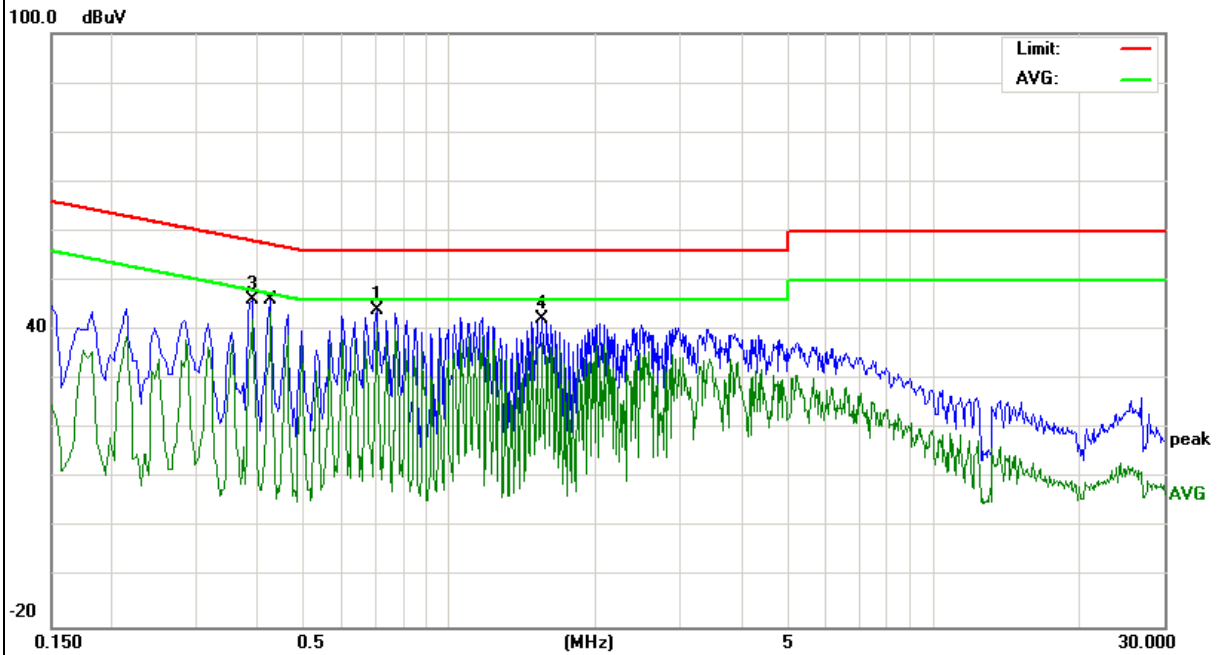

EUT :	Tablet PC	Model Name. :	TBWP
Temperature :	26 °C	Relative Humidity :	54%
Pressure :	1010hPa	Test Date :	2015-06-22
Test Mode :	Mode 1	Phase :	N
Test Voltage :	DC5V Form Adapter AC 120V/60Hz		

Frequency (MHz)	Reading Level (dBμV)	Correct Factor (dB)	Measure-ment (dBμV)	Limits (dBμV)	Margin (dB)	Remark
0.1780	35.56	9.62	45.18	64.57	-19.39	QP
0.1780	21.42	9.62	31.04	54.57	-23.53	AVG
0.3860	33.12	9.41	42.53	58.15	-15.62	QP
0.7019	28.97	9.78	38.75	56.00	-17.25	QP
0.7019	18.84	9.78	28.62	46.00	-17.38	AVG

Remark:

1. All readings are Quasi-Peak and Average values.
2. Factor = Insertion Loss + Cable Loss.

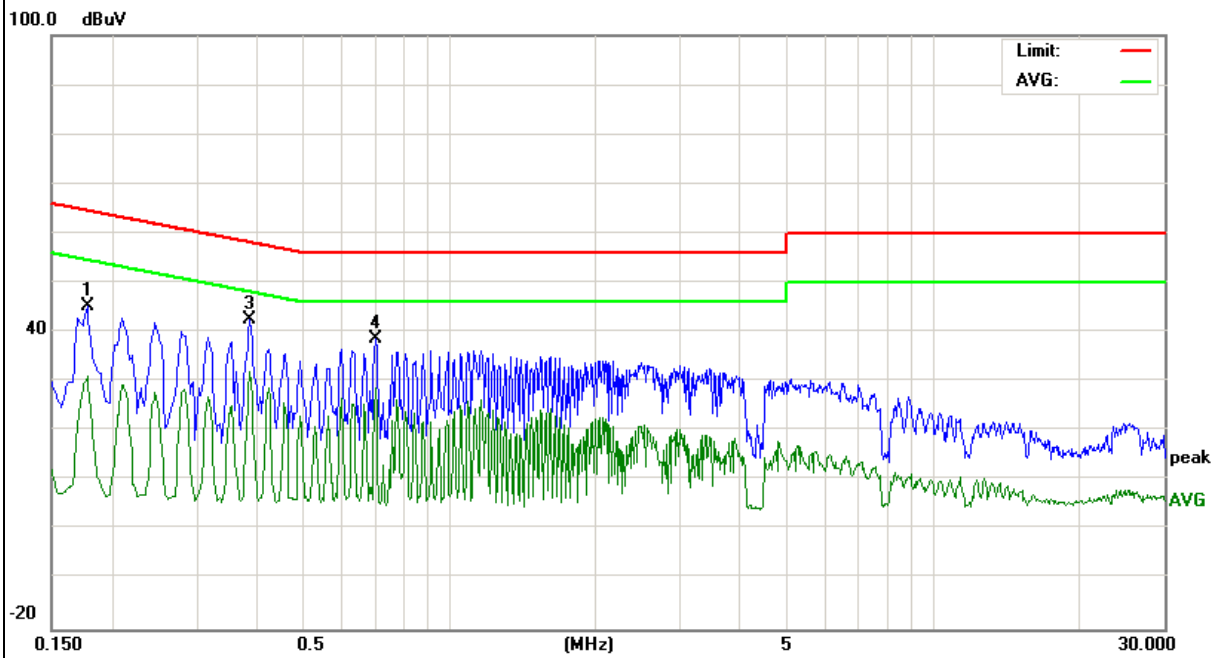

EUT :	Tablet PC	Model Name. :	TBWP
Temperature :	26 °C	Relative Humidity :	54%
Pressure :	1010hPa	Test Date :	2015-06-22
Test Mode :	Mode 1	Phase :	L
Test Voltage :	DC5V Form Adapter AC 240V/60Hz		

Frequency (MHz)	Reading Level (dBμV)	Correct Factor (dB)	Measure-ment (dBμV)	Limits (dBμV)	Margin (dB)	Remark
1.5820	36.43	9.68	46.11	56.00	-9.89	QP
1.5820	29.02	9.68	38.70	46.00	-7.30	AVG
3.5780	38.32	9.69	48.01	56.00	-7.99	QP
3.5780	30.84	9.69	40.53	46.00	-5.47	AVG
8.9540	40.21	9.71	49.92	60.00	-10.08	QP
9.8500	32.72	9.72	42.44	50.00	-7.56	AVG
11.9220	37.79	9.75	47.54	60.00	-12.46	QP

Remark:

1. All readings are Quasi-Peak and Average values.
2. Factor = Insertion Loss + Cable Loss.

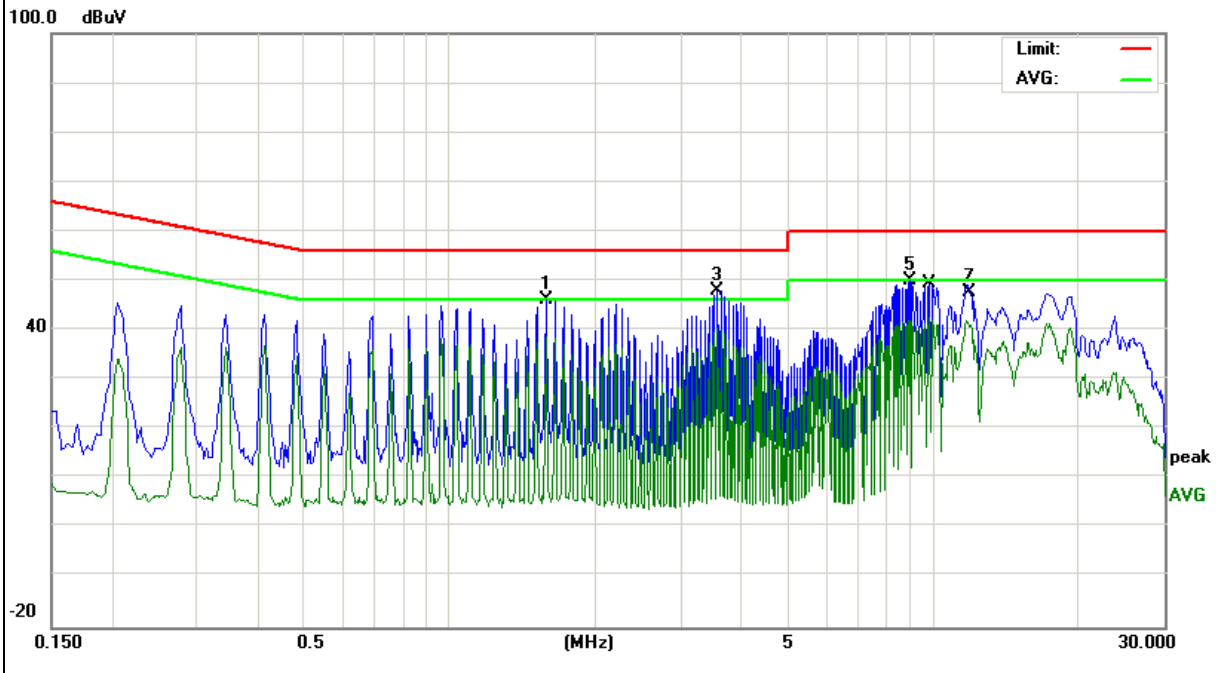

EUT :	Tablet PC	Model Name. :	TBWP
Temperature :	26 °C	Relative Humidity :	54%
Pressure :	1010hPa	Test Date :	2015-06-22
Test Mode :	Mode 1	Phase :	N
Test Voltage :	DC5V Form Adapter AC 240V/60Hz		

Frequency (MHz)	Reading Level (dBμV)	Correct Factor (dB)	Measure-ment (dBμV)	Limits (dBμV)	Margin (dB)	Remark
0.2060	35.28	9.61	44.89	63.36	-18.47	QP
0.2100	20.20	9.61	29.81	53.20	-23.39	AVG
1.7300	31.08	9.67	40.75	56.00	-15.25	QP
1.7300	22.24	9.67	31.91	46.00	-14.09	AVG
3.6700	23.29	9.69	32.98	46.00	-13.02	AVG
3.7380	31.70	9.69	41.39	56.00	-14.61	QP
8.5180	23.99	9.70	33.69	50.00	-16.31	AVG
8.6540	32.80	9.71	42.51	60.00	-17.49	QP
18.9940	20.58	9.94	30.52	50.00	-19.48	AVG
24.2060	35.44	9.92	45.36	60.00	-14.64	QP

Remark:

1. All readings are Quasi-Peak and Average values.
2. Factor = Insertion Loss + Cable Loss.

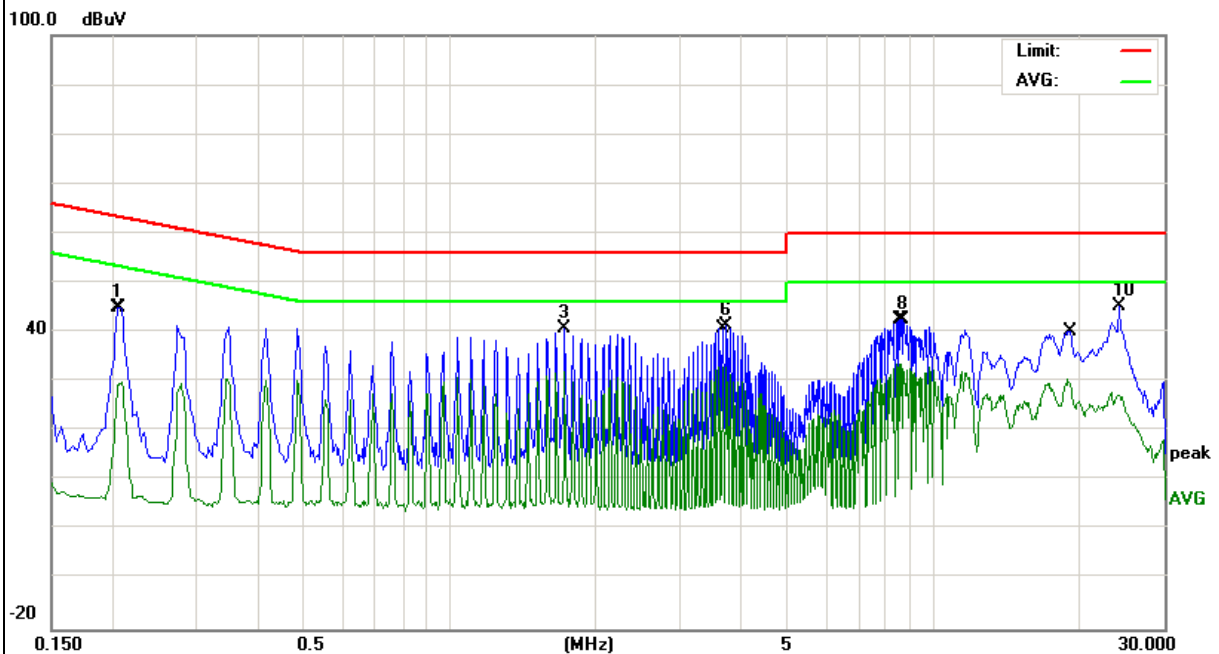

3.2 RADIATED EMISSION MEASUREMENT

3.2.1 LIMITS OF RADIATED EMISSION MEASUREMENT

FREQUENCY (MHz)	Class A (at 10m)	Class B (at 3m)
	dBuV/m	dBuV/m
30 ~ 88	39.0	40.0
88 ~ 216	43.5	43.5
216 ~ 960	46.5	46.0
Above 960	49.5	54.0

Notes:

- (1) The limit for radiated test was performed according to as following:
FCC PART 15B /ICES-003.
- (2) The tighter limit applies at the band edges.
- (3) Emission level (dBuV/m)=20log Emission level (uV/m).

3.2.2 TEST PROCEDURE

Test Arrangement for Radiated Emissions up to 1 GHz

- a. The EUT was placed on the top of a rotating table 0.8 meters above the ground at an accredited test facility. The table was rotated 360 degrees to determine the position of the highest radiation.
- b. The EUT was set 3 meters away from the interference-receiving antenna, which was mounted on the top of a variable-height antenna tower.
- c. The antenna is a broadband antenna, and its height is varied from one meter to four meters above the ground to determine the maximum value of the field strength. Both horizontal and vertical polarizations of the antenna are set to make the measurement.
- d. For each suspected emission, the EUT was arranged to its worst case and then the antenna was tuned to heights from 1 meter to 4 meters and the rotatable table was turned from 0 degrees to 360 degrees to find the maximum reading.

Note: The resolution bandwidth and video bandwidth of test receiver/spectrum analyzer is 120kHz for quasi-peak detection (QP) at frequency below 1GHz.

Test Arrangement for Radiated Emissions above 1 GHz.

- a. The EUT was placed on the top of a rotating table 0.8 meters above the ground at an accredited chamber room. The table was rotated 360 degrees to determine the position of the highest radiation.
- b. The EUT was set 3 meters away from the interference-receiving antenna, which was mounted on the top of a variable-height antenna tower.
- c. The height of antenna can be varied from one meter to four meters, the height of adjustment depends on the EUT height and the antenna 3dB beamwidth both, to detect the maximum value of the field strength.Both horizontal and vertical polarizations of the antenna are set to make the measurement.
- d. For each suspected emission, the EUT was arranged to its worst case and then the antenna was tuned to heights and the rotatable table was turned from 0 degrees to 360 degrees to find the maximum reading.

Note: For the hand-held device, the EUT should be measured for all 3 axes and only the worst case is recorded in the report
During the radiated emission test, the Spectrum Analyzer was set with the following configurations:

Frequency Band (MHz)	Function	Resolution bandwidth	Video Bandwidth
30 to 1000	QP	120 kHz	300 kHz
Above 1000	Peak	1 MHz	1 MHz
	Peak	1 MHz	10 Hz

3.2.3 TEST SETUP

(A) Radiated Emission Test Set-Up Frequency Below 1 GHz

For Radiated Emission 30~1000MHz

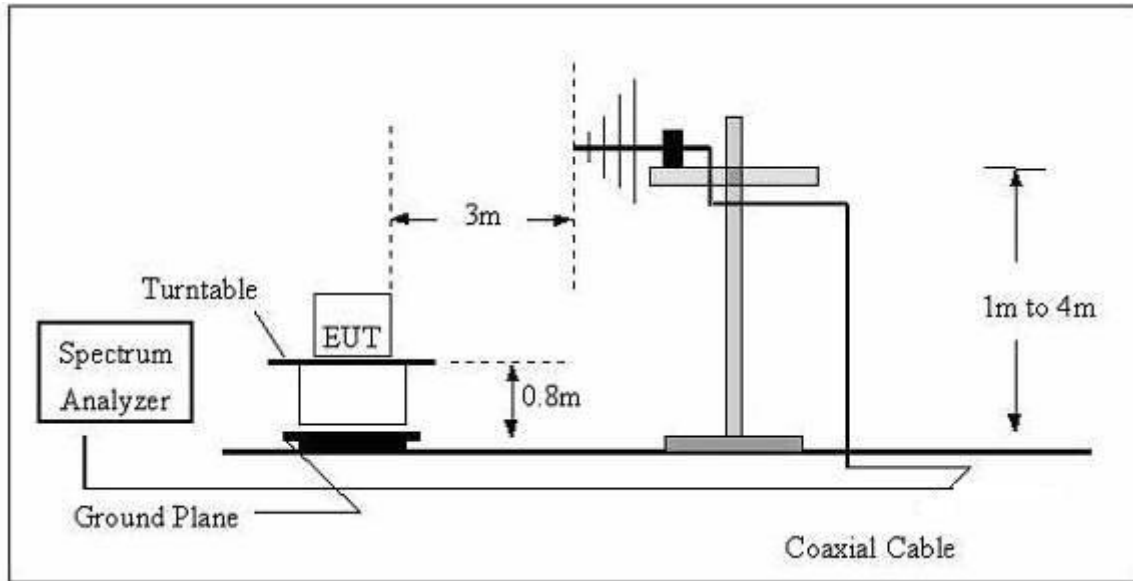

(B) Radiated Emission Test Set-Up Frequency Above 1GHz

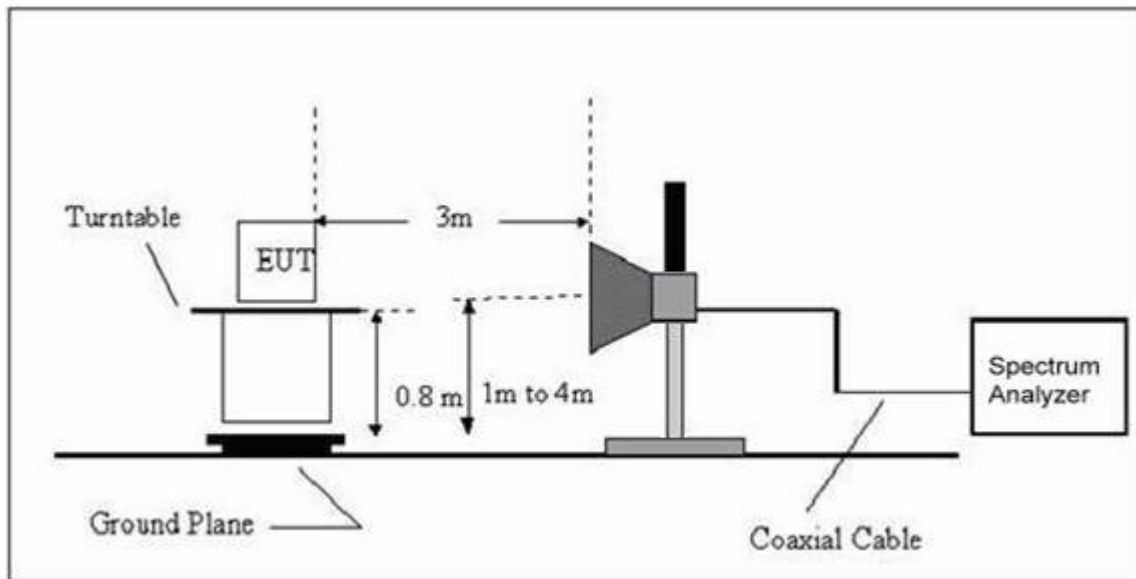

3.2.4 EUT OPERATING CONDITIONS

The EUT tested system was configured as the statements of 2.3 Unless otherwise a special operating condition is specified in the follows during the testing.

3.2.5 TEST RESULTS

TEST RESULTS (30~1000 MHz)

EUT :	Tablet PC	Model Name :	TBWP
Temperature :	24 °C	Relative Humidity :	54%
Pressure :	1010 hPa	Test Date :	2015-06-22
Test Mode :	Mode 1	Polarization :	Horizontal
Test Power :	AC 120V/60Hz		

Freq. (MHz)	Reading (dBuV)	Factor (dBuV)	Measurement (dBuV)	Limit (dBuV)	Over (dB)	Remark
53.1313	14.46	9.80	24.26	40.00	-15.74	QP
158.6676	21.60	10.47	32.07	43.50	-11.43	QP
184.4898	23.06	10.66	33.72	43.50	-9.78	QP
264.7457	25.12	13.75	38.87	46.00	-7.13	QP
387.9920	19.13	17.81	36.94	46.00	-9.06	QP
480.5276	17.03	19.91	36.94	46.00	-9.06	QP

Remark:

Factor = Antenna Factor + Cable Loss - Amplifier.

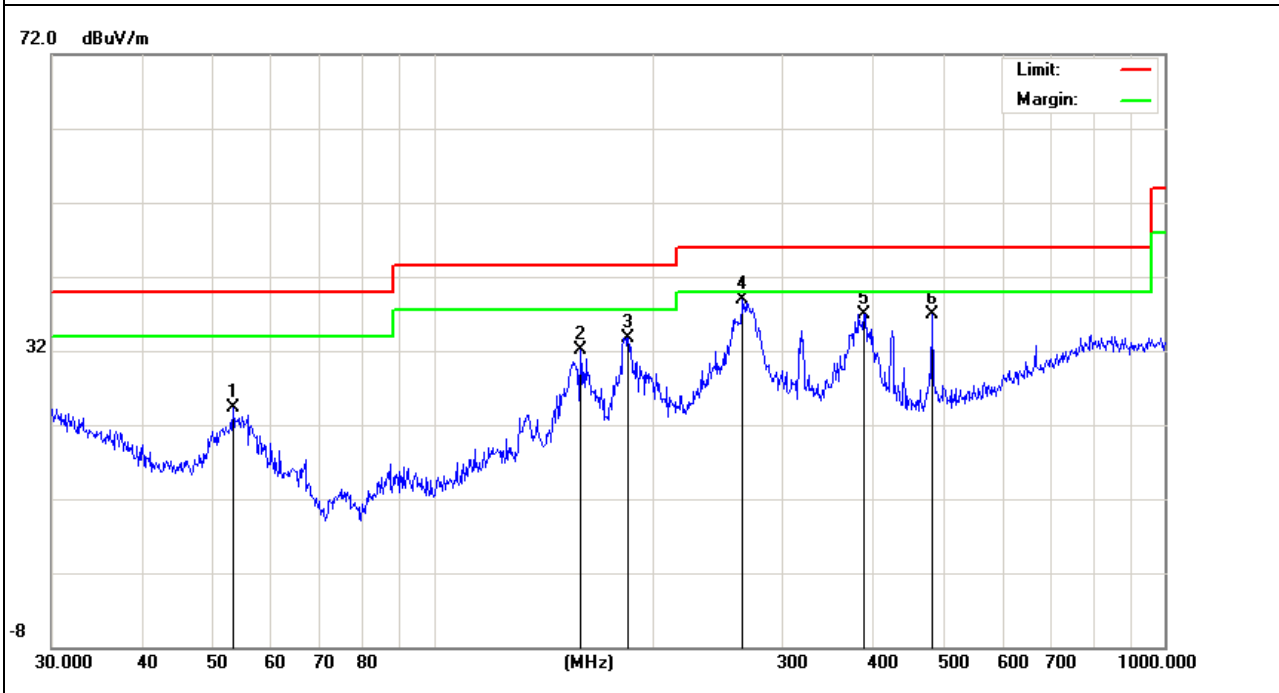

EUT :	Tablet PC	Model Name :	TBWP
Temperature :	24 °C	Relative Humidity :	54%
Pressure :	1010 hPa	Test Date :	2015-06-22
Test Mode :	Mode 1	Polarization :	Vertical
Test Power :	AC 120V/60Hz		

Freq. (MHz)	Reading (dBuV)	Factor (dBuV)	Measurement (dBuV)	Limit (dBuV)	Over (dB)	Remark
34.1561	11.26	17.15	28.41	40.00	-11.59	QP
53.5052	15.63	9.69	25.32	40.00	-14.68	QP
130.8369	21.36	11.85	33.21	43.50	-10.29	QP
271.3245	15.50	13.83	29.33	46.00	-16.67	QP
425.0280	14.56	18.81	33.37	46.00	-12.63	QP
668.1422	13.30	23.91	37.21	46.00	-8.79	QP

Remark:
Factor = Antenna Factor + Cable Loss - Amplifier.

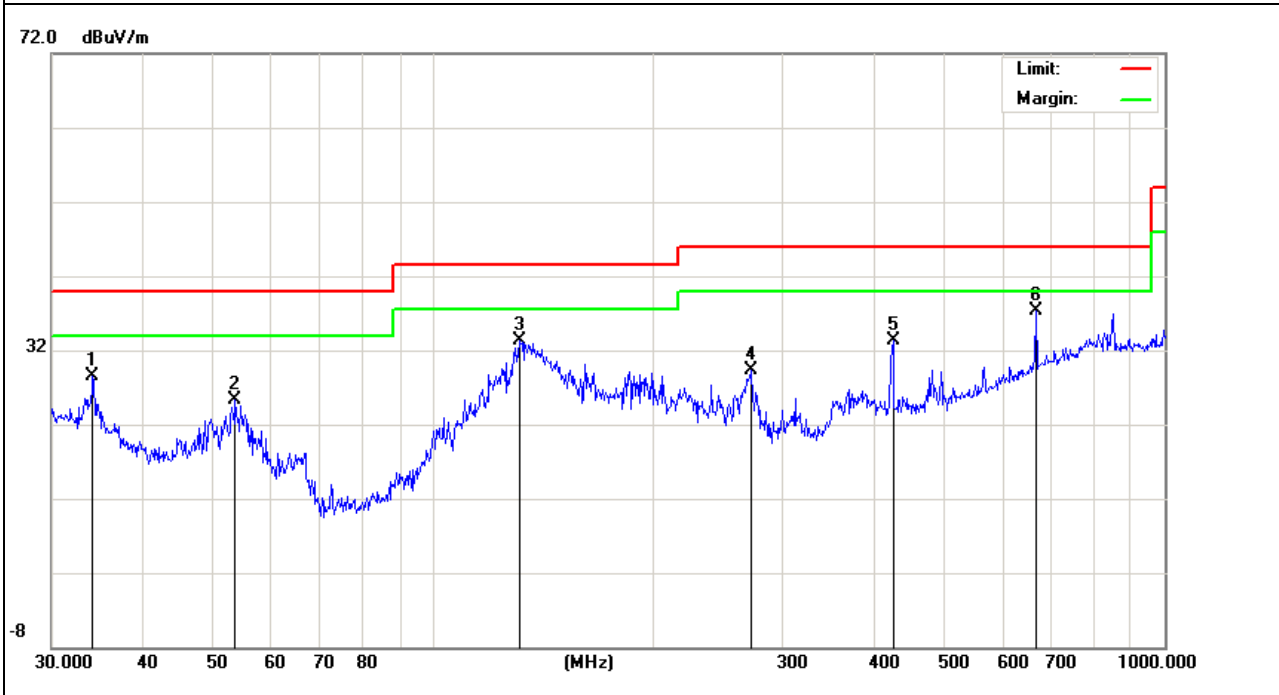

3.2.6 TEST RESULTS(1000~6000MHz)

Polar (H/V)	Frequency	Meter Reading	Factor	Emission Level	Limits	Margin	Remark
	(MHz)	(dBm)	(dB)	(dBm)	(dBm)	(dB)	
V	1894.621	85.96	-17.15	68.81	74.00	-5.19	peak
V	1894.621	60.82	-17.15	43.67	54.00	-10.33	AVG
V	2657.389	82.37	-15.76	66.61	74.00	-7.39	peak
V	2657.389	59.34	-15.76	43.58	54.00	-10.42	AVG
V	4013.629	76.71	-11.22	65.49	74.00	-8.51	peak
V	4013.629	53.98	-11.22	42.76	54.00	-11.24	AVG
H	1896.351	81.81	-17.14	64.67	74.00	-9.33	peak
H	1896.351	58.40	-17.14	41.26	54.00	-12.74	AVG
H	3116.378	82.03	-15.54	66.49	74.00	-7.51	peak
H	3116.378	58.51	-15.54	42.97	54.00	-11.03	AVG
H	4361.254	75.44	-10.13	65.31	74.00	-8.69	peak
H	4361.254	51.49	-10.13	41.36	54.00	-12.64	AVG

Remark:

Absolute Level= ReadingLevel+ Factor, Margin= Absolute Level - Limit

4. EUT TEST PHOTO

Radiated Measurement Photos

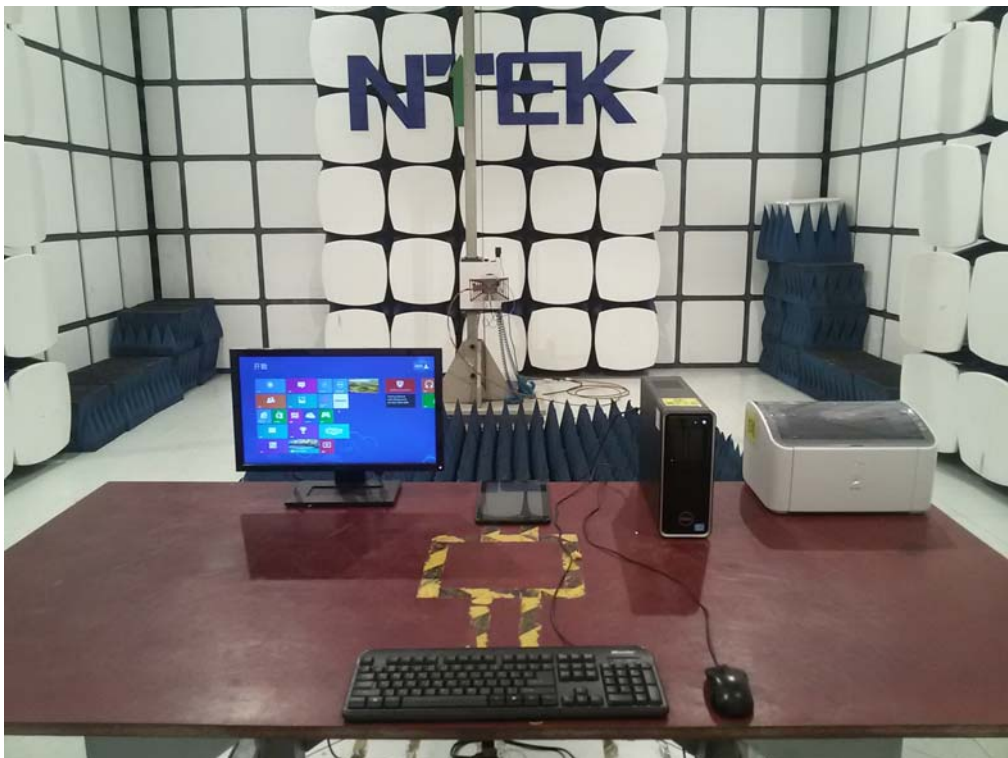

Conducted Measurement Photos

