



EMC Technologies Pty Ltd
ABN 82 057 105 549
176 Harrick Road
Keilor Park Victoria Australia 3042

Ph: + 613 9365 1000
Fax: + 613 9331 7455
Email: sales@emctech.com.au

**EMI TEST REPORT FOR CERTIFICATION
to
FCC PART 15 Subpart C (Section 15.209)**



Test Sample: Emberpulse In Home Display
Model: BBSE

Radio Modules: Ti Wi-Fi/Bluetooth Modules WL1831MODGB
Telegesis ZigBee Module ETRX357-LRS

Report Number: M150515-2 A
(supersedes Report M150515-2)

Issue Date: 15 July 2015

EMC Technologies Pty Ltd reports apply only to the specific samples tested under stated test conditions. It is the manufacturer's responsibility to assure that additional production units of this model are manufactured with identical electrical and mechanical components. EMC Technologies Pty Ltd shall have no liability for any deductions, inferences or generalisations drawn by the client or others from EMC Technologies Pty Ltd issued reports. This report shall not be used to claim, constitute or imply product endorsement by EMC Technologies Pty Ltd.

  <p>Accreditation No. 5292</p>	<p>Accredited for compliance with ISO/IEC 17025. The results of the tests, calibrations and/or measurements included in this document are traceable to Australian/national standards. NATA is a signatory to the ILAC Mutual Recognition Arrangement for the mutual recognition of the equivalence of testing, calibration and inspection reports.</p> <p style="text-align: center;">This document shall not be reproduced except in full.</p>
---	--

EMI TEST REPORT FOR CERTIFICATION
to
FCC PART 15 Subpart C (Section 15.209)
EMC Technologies Report No. M150515-2 A
Issue Date: 15 July 2015

CONTENTS

1.0	INTRODUCTION	4
2.0	GENERAL INFORMATION	4
3.0	SPURIOUS EMI MEASUREMENTS	6
4.0	COMPLIANCE STATEMENT	8
5.0	UNCERTAINTIES	8

APPENDIX A: MEASUREMENT INSTRUMENT DETAILS
APPENDIX B: GRAPHS OF EMI MEASUREMENT



Accredited for compliance with ISO/IEC 17025. The results of the tests, calibrations and/or measurements included in this document are traceable to Australian/national standards. NATA is a signatory to the ILAC Mutual Recognition Arrangement for the mutual recognition of the equivalence of testing, calibration and inspection reports.

This document shall not be reproduced except in full.

**EMI TEST REPORT FOR CERTIFICATION
to
FCC PART 15 Subpart C (Section 15.209)**

Report Number: M150515-2 A

Test Sample: Emberpulse Home Display/Automation Device
Model: BBSE

Radio Modules: Ti Wi-Fi / Bluetooth modules WL1831MODGB
Telegesis ZigBee Module ETRX357-LRS

FCC ID: Z64-WL18SBMOD
S4GEM35XB

Equipment Type: Intentional Radiator (Transceiver)

Emberpulse manufacturer: Embertec Pty Ltd
Address: 182 Fullarton Rd Dulwich SA 5065 Australia
Phone: +61 8 8334 3300
Contact: Nathan Kuchel
Email: Nathan@embertec.com

Test Standard/s: FCC Part 15 – Radio Frequency Devices
FCC Part 15 Subpart C – Intentional Radiators
Section 15.209 – Radiated emission limits; general requirements.
ANSI C63.4 – 2009 – American National Standard for Methods of
Measurement of Radio - Noise Emissions from Low-Voltage Electrical and
Electronic Equipment in the Range of 9 kHz to 40 GHz

Test Dates: 22 June ~ 1 July 2015



Test Engineer: Larry Phuah
EMC Test Engineer

Attestation: *I hereby certify that the device(s) described herein were tested as described in this report and that the data included is that which was obtained during such testing.*



Authorised Signatory: Chris Zombolas
Technical Director
EMC Technologies Pty Ltd



Accredited for compliance with ISO/IEC 17025. The results of the tests, calibrations and/or measurements included in this document are traceable to Australian/national standards. NATA is a signatory to the ILAC Mutual Recognition Arrangement for the mutual recognition of the equivalence of testing, calibration and inspection reports.

This document shall not be reproduced except in full.

EMI TEST REPORT FOR CERTIFICATION to FCC PART 15 Subpart C (Section 15.209)

1.0 INTRODUCTION

EMI testing was performed on the Emberpulse Home Display/Automation Device, Model: BBSE with Ti Wi-Fi/Bluetooth Module, Model: WL1831MODGB and Telegesis ZigBee Module, Model: ETRX357-LRS.

Test results and procedures were performed in accordance with the following Federal Communications Commission (FCC) standards/regulations:

47 CFR, Part 15, Subpart C:

Section 15.209: Radiated Emission Limits (General requirements)

The test sample **complied** with the requirements of 47 CFR, Part 15 Subpart C - Section 15.209.

The measurement procedure used was in accordance with ANSI C63.4-2009. The instrumentation conformed to the requirements of ANSI C63.2-2009.

1.1 Summary of Results

15.209 Radiated EMI: (0.009-30 MHz)	*Complied limit, margin of 0.0 dB
15.209 Radiated EMI: (30-1000 MHz)	*Complied limit, margin of 1.8 dB
15.209 Radiated EMI: (above 1 GHz)	Complied limit, margin of 5.3 dB

*This result is within the laboratory's measurement uncertainty. Refer to section 5.0.

1.2 Modifications by EMC Technologies

No modifications were required.

2.0 GENERAL INFORMATION

(Information supplied by the Client)

The Equipment Under Test (EUT) was identified as follows:

2.1 EUT (Transmitter) Details

Radio Module:	Wi-Fi/Bluetooth module WL1831MODGB
Operating frequency (MHz):	2400 – 2484
FCC ID:	Z64-WL18SBMOD
Radio Module:	ZigBee module ETRX357-LRS
Operating frequency (MHz):	2400
FCC ID:	S4GEM35XB

2.2 EUT (Host) Details

Test Sample:	Emberpulse Home Display/Automation Device
Model Number:	BBSE
Manufacturer:	Embertec Pty Ltd
Microprocessor:	Freescale I.MX280
Crystal Frequencies:	24 MHz
Highest operating freq:	450 MHz
Input Supply:	5V DC, 0.5A



Accredited for compliance with ISO/IEC 17025. The results of the tests, calibrations and/or measurements included in this document are traceable to Australian/national standards. NATA is a signatory to the ILAC Mutual Recognition Arrangement for the mutual recognition of the equivalence of testing, calibration and inspection reports.

This document shall not be reproduced except in full.

Tested With: KPTEC AC Adapter
Model Number: K05S050080A 1518
Input Supply: 100-240V AC, 50-60 Hz, 200mA
Output Supply: 5.0V DC, 800mA

Emberpulse will be used in the home and will connect to the home router for internet cloud connection via Wi-Fi. Emberpulse will also connect to a smart meter via ZigBee to read home energy consumption. Home automation devices will connect to the Emberpulse via Wi-Fi, ZigBee and/or Bluetooth. This unit would be used away from the body, normally located next to the home router.

2.3 Operational Description

Testing was performed as per the client's instructions, the Model BBSE powered via 100-240V AC, 50-60Hz AC adaptor with Wi-Fi communication to pc for internet cloud access. To simulate normal operation the unit was connected to a smart meter (supplied by client) via ZigBee and to TI Bluetooth sensor tab.

2.4 Test Configuration

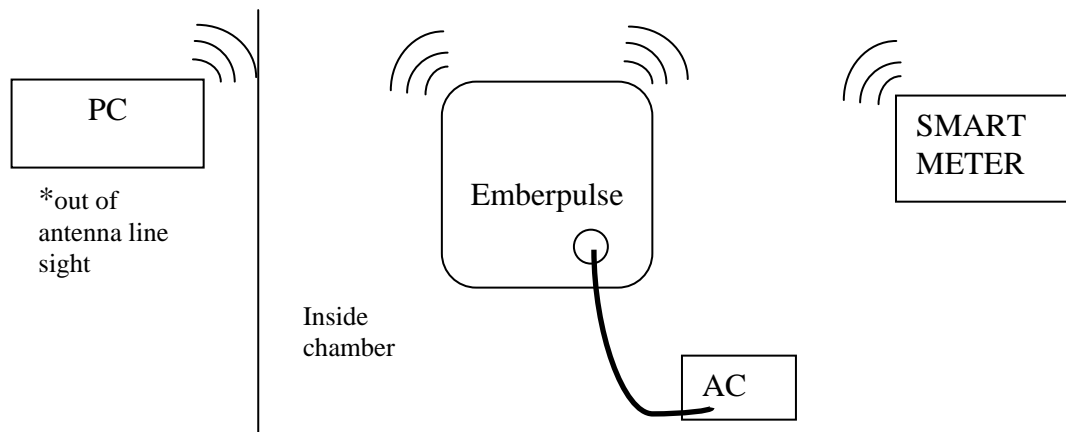

2.5 Test Procedure

Emission measurements were performed in accordance with the procedures of ANSI C63.4-2009. Radiated emission tests were performed at a distance of 10, 3 and 1 metres from the EUT.



2.6 Test Facility

2.6.1 General

Measurements were performed at EMC Technologies' laboratory in Keilor Park, Victoria Australia.

EMC Technologies Pty Ltd is listed by the FCC as a test laboratory able to perform compliance testing for the public. EMC Technologies is listed as an FCC part 47CFR 2.948 test lab and may perform the testing required under Parts 15 and 18 – **FCC Registration Number 90560**

EMC Technologies Pty Ltd has also been accredited as a Conformity Assessment Body (CAB) by Australian Communications and Media Authority (ACMA) under the APECTEL MRA and is designated to perform compliance testing on equipment subject to Declaration of Conformity

  <p>Accreditation No. 5292</p>	<p>Accredited for compliance with ISO/IEC 17025. The results of the tests, calibrations and/or measurements included in this document are traceable to Australian/national standards. NATA is a signatory to the ILAC Mutual Recognition Arrangement for the mutual recognition of the equivalence of testing, calibration and inspection reports.</p> <p style="text-align: center;">This document shall not be reproduced except in full.</p>
---	--

(DoC) and Certification under Parts 15 and 18 of the FCC Commission's rules – **Registration Number 494713 and Designation number AU0001.**

EMC Technologies' indoor open area test site (iOATS) has been accepted by Industry Canada for the performance of radiated measurements in accordance with RSS-Gen, Issue 8 - **Industry Canada iOATS number - IC 3569B**

2.6.2 NATA Accreditation

NATA is the Australian National laboratory accreditation body and has accredited EMC Technologies to operate to the IEC/ISO17025 requirements. A major requirement for accreditation is the assessment of the company and its personnel as being technically competent in testing to the standards. This requires fully documented test procedures, continued calibration of all equipment to the National Standard at the National Measurements Institute (NMI) and an internal quality system to ISO 17025. NATA is an ILAC member and has mutual recognition agreements with the National Voluntary Laboratory Accreditation Program (NVLAP) and the American Association for Laboratory Accreditation (A²LA).

All testing in this report has been conducted in accordance with EMC Technologies' scope of NATA accreditation.

The current full scope of accreditation can be found on the NATA website: www.nata.com.au
The scope also includes a large number of emissions, immunity, SAR, EMR and Safety standards.

2.7 Test Equipment Calibration

Measurement instrumentation and transducers were calibrated in accordance with the applicable standards by a NATA accredited laboratory such as Keysight Technologies (Australia) Pty Ltd or the National Measurement Institute (NMI). All equipment calibration is traceable to Australia national standards at the National Measurements Institute. The reference antenna calibration was performed by Liberty Labs LLC and the working antennas (biconilog and horn) calibrated by Liberty Labs LLC and EMC Technologies respectively. The complete list of test equipment used for the measurements, including calibration dates and traceability is contained in Appendix A

3.0 SPURIOUS EMISSION MEASUREMENTS

3.1 Test Procedure

Testing was performed in accordance with the requirements of FCC Part 15.209.

Radiated emission measurements were performed to the limits as per section 15.209. The measurements were made at the open area test site.

The EUT was set up on the table top (placed on turntable) of total height 80 cm above the ground plane, and operated as described in section 2 of this report. The test frequency range was sub-divided into smaller bands with sufficient frequency resolution to permit reliable display and identification of possible EMI peaks while also permitting fast frequency scan times. A calibrated Biconilog antenna was used for measurements between 30 MHz and 1000 MHz. Calibrated EMCO 3115 and ETS standard gain horn antennas were used for measurements between 1 to 40 GHz.



The measurement of emissions between 30 - 1000 MHz was measured with the resolution bandwidth of 120 kHz and the video bandwidth of 300 kHz.

The measurement of emissions above 1000 MHz was measured using a following setting:

Peak measurements setting: RBW = VBW = 1 MHz

Average measurements setting: RBW = 1 MHz and VBW = 10 Hz

The receiver bandwidth was set to 6 dB.

  <p>Accreditation No. 5292</p>	<p>Accredited for compliance with ISO/IEC 17025. The results of the tests, calibrations and/or measurements included in this document are traceable to Australian/national standards. NATA is a signatory to the ILAC Mutual Recognition Arrangement for the mutual recognition of the equivalence of testing, calibration and inspection reports.</p> <p style="text-align: center;">This document shall not be reproduced except in full.</p>
---	--

The EUT was slowly rotated with the Peak Detector set to Max-Hold. This was performed for two antenna heights. When an emission was located, it was positively identified and its maximum level found by rotating the automated turntable, and by varying the antenna height. Each significant peak was investigated with the Peak/Average Detectors. The measurement data for each frequency range was corrected for cable losses, antenna factors and preamplifier gain. This process was performed for both horizontal and vertical antenna polarisations.

3.2 Plotting of Measurement Data for Radiated Emissions

The stored measurement data was combined to form a single graph which comprised of all the frequency sub-ranges. The accumulated EMI (EUT ON) was plotted as the Red trace.

The highest recorded EMI signals are shown in the table below the graph. For radiated EMI, each numbered peak is listed as a frequency, peak field strength, quasi-peak field strength and the margin relative to the limit in dB. A negative margin is the deviation of the recorded value below the limit.

3.3 Calculation of field strength

The field strength was calculated automatically by the software using all the pre-stored calibration data. The method of calculation is shown below:

$E = V + AF - G + L$ Where:

- E** = Radiated Field Strength in dB μ V/m.
- V** = EMI Receiver Voltage in dB μ V. (measured value)
- AF** = Antenna Factor in dB(m⁻¹). (stored as a data array)
- G** = Preamplifier Gain in dB. (stored as a data array)
- L** = Cable loss in dB. (stored as a data array of Insertion Loss versus frequency)

- **Example Field Strength Calculation**

Assuming a receiver reading of 34.0 dB μ V is obtained at 90 MHz, the Antenna Factor at that frequency is 9.2 dB. The cable loss is 1.9 dB while the preamplifier gain is 20 dB. The resulting Field Strength is therefore as follows:

$$34.0 + 9.2 + 1.9 - 20 = 25.1 \text{ dB}\mu\text{V/m}$$

$$35.0$$

3.4 Radiated Emissions (Spurious and Harmonics)

3.4.1 Frequency Band: 0.009 – 30 MHz

Testing was performed at a distance of 10 metres

Frequency MHz	Polarisation	QP Measured dB μ V/m	QP Limit dB μ V/m	Δ QP \pm dB
9.865	Perpendicular	49.0	49.0	0.0*
9.900	Perpendicular	48.0	49.0	-1.0*
10.46	Z-Axis	47.6	49.0	-1.4*
0.544	Perpendicular	41.4	52.0	-10.6
0.492	Parallel	41.9	52.9	-11.0

*This result is within the laboratory's measurement uncertainty. Refer to section 5.0.

Results: The highest radiated emission peak occurred at 9.865 MHz and complied with FCC quasi peak limit by a margin of 0.0 dB. Refer to Appendix B (graphs 1 – 3).



Accredited for compliance with ISO/IEC 17025. The results of the tests, calibrations and/or measurements included in this document are traceable to Australian/national standards. NATA is a signatory to the ILAC Mutual Recognition Arrangement for the mutual recognition of the equivalence of testing, calibration and inspection reports.

This document shall not be reproduced except in full.

3.4.2 Frequency Band: 30 – 1000 MHz

Testing was performed at a distance of 10 metres.

Frequency MHz	Polarisation	QP Measured dB μ V/m	QP Limit dB μ V/m	Δ QP \pm dB
30.04	Vertical	27.7	29.5	-1.8*
120.01	Vertical	28.0	33.0	-5.0*
33.60	Vertical	23.3	29.5	-6.2
120.00	Horizontal	23.2	33.0	-9.8

*This result is within the laboratory's measurement uncertainty. Refer to section 5.0.

Results: The highest radiated emission peak occurred at 30.04 MHz and complied with FCC quasi peak limit by a margin of 1.8 dB. Refer to Appendix B (graphs 4 & 5).

3.4.3 Frequency Band: 1 – 24 GHz

Testing was performed at a distance of 3 metres (1 – 18 GHz) and 1 metre (18 – 24 GHz).

Frequency MHz	Polarisation	Measured dB μ V/m	QP Limit dB μ V/m	$\Delta \pm$ dB	Detector
13918.31	Vertical	48.7	54.0	-5.3	AV
11571.31	Horizontal	68.4	74.0	-5.6	PK
14061.79	Horizontal	47.5	54.0	-6.5	AV
11769.54	Horizontal	45.0	54.0	-9.0	AV
3535.7	Horizontal	65.0	74.0	-9.0	PK
2850.78	Vertical	64.9	74.0	-9.1	PK

Results: The highest radiated emission peak occurred at 13.92 GHz and complied with FCC quasi peak limit by a margin of 5.3 dB. Refer to Appendix B (graphs 6 – 13)

4.0 COMPLIANCE STATEMENT

The Emberpulse Home Display/Automation Device, Model: BBSE with Ti Wi-Fi/Bluetooth Module – Model: WL1831MODGB (FCC ID: Z64-WL18SBMOD) and Telegesis ZigBee Module – Model: ETRX357-LRS (FCC ID: S4GEM35XB) **complied** with the requirements of 47 CFR, Part 15 Subpart C - Rules for Radio Frequency Devices (intentional radiators), Section 15.209 - Radiated emission limits; general requirements.

5.0 UNCERTAINTY

EMC Technologies has evaluated the equipment and the methods used to perform emission testing. The estimated measurement uncertainty for emission tests shown within this report are as follows:

Radiated Emissions

9 kHz to 30 MHz	± 4.1 dB
30 MHz to 300 MHz	± 5.1 dB
300 MHz to 1000 MHz	± 4.7 dB
1 GHz to 18 GHz	± 4.6 dB

The above expanded uncertainties are based on the standard uncertainty multiplied by a coverage factor of $k = 2$ and providing a level of confidence of approximately 95 %.

Application of measurement uncertainty for this report:

The referenced uncertainty standard specifies that determination of compliance shall be based on measurements without taking into account measurement instrumentation uncertainty. However, the measurement uncertainty shall appear in the test report.

 <p>Accreditation No. 5292</p>	<p>Accredited for compliance with ISO/IEC 17025. The results of the tests, calibrations and/or measurements included in this document are traceable to Australian/national standards. NATA is a signatory to the ILAC Mutual Recognition Arrangement for the mutual recognition of the equivalence of testing, calibration and inspection reports.</p> <p style="text-align: center;">This document shall not be reproduced except in full.</p>
---	--

TEST REPORT APPENDICES



APPENDIX A: MEASUREMENT INSTRUMENT DETAILS
APPENDIX B: GRAPHS OF EMI MEASUREMENT

APPENDIX A MEASUREMENT INSTRUMENTATION DETAILS

Equipment Type	Make/Model/Serial Number	Last Cal. dd/mm/yy	Due Date dd/mm/yy	Cal. Interval
Chamber	Frankonia SAC-10-2 (R-139)	08/01/2015	08/01/2016	1 Year, *1
EMI Receiver	R&S ESU40 20 Hz – 40 GHz Sn: 100392 (R-140)	09/10/2014	09/10/2015	1 Year, *2
	R&S ESU40 20 Hz – 40 GHz Sn: 100182 (R-037)	12/02/2015	12/02/2016	1 Year, *2
Antennas	EMCO 6502 Active Loop A-231 9kHz-30MHz Sn. 9311-2801	20/08/2012	20/08/2015	3 Year, *2
	SUNOL JB6 BICONILOG 30 – 6000 MHz Sn. A012312 (A-363)	16/05/2014	16/05/2016	2 Year, *2
	EMCO 3115 Broadband Horn 1 – 18 GHz Sn. 8908-3282 (A-004)	09/05/2013	09/05/2016	3 Year, *1
	ETS-Lindgren Horn 3160-09 18-26.5 GHz Sn. 66032 (A-307)	12/11/2012	12/11/2015	3 Year, *1
	ETS-Lindgren Horn 3160-08 12.4 – 18 GHz Sn. 66032 (A-263)	09/11/2012	09/11/2015	3 Year, *1
Cables	Room 12 cable Mast (C-437)	24/04/2015	24/04/2016	1 Year, *1
	Room 12 Inbuilt cable Panel 1 to 10m (C-422)	24/04/2015	24/04/2016	1 Year, *1
	Sucoflex 104A Huber & Suhner (C-461)	18/07/2014	18/07/2015	1 Year, *1
	Sucoflex 102 Huber & Suhner Sn. 27319/2 (C-273)	19/05/2015	19/05/2016	1 Year, *1
Pre-Amplifier	Electronic Development SG18-B3015 1 – 18 GHz Sn. 1 (A-288)	14/05/2015	14/05/2016	1 Year, *1
Notch Filter	Micro-Tronics BRM50702 2.4 GHz Band Reject Filter Sn. 125 (F-016)	13/03/2015	13/03/2016	1 Year, *1

Note *1. Internal NATA calibration.

Note *2. External NATA / A2LA calibration

  <small>Accreditation No. 5292</small>	<p>Accredited for compliance with ISO/IEC 17025. The results of the tests, calibrations and/or measurements included in this document are traceable to Australian/national standards. NATA is a signatory to the ILAC Mutual Recognition Arrangement for the mutual recognition of the equivalence of testing, calibration and inspection reports.</p> <p style="text-align: center;">This document shall not be reproduced except in full.</p>
---	--

APPENDIX B

Graphs of EMI Measurements

RADIATED EMI

Graph 1:	Parallel	0.009 – 30 MHz
Graph 2:	Perpendicular	0.009 – 30 MHz
Graph 3:	Z-Axis	0.009 – 30 MHz
Graph 4:	Vertical Polarity	30 – 1000 MHz
Graph 5:	Horizontal Polarity	30 – 1000 MHz
Graph 6:	Vertical Polarity (average)	1 – 18 GHz
Graph 7:	Vertical Polarity (average)	18 – 24 GHz
Graph 8:	Vertical Polarity (peak)	1 – 18 GHz
Graph 9:	Vertical Polarity (peak)	18 – 24 GHz
Graph 10:	Horizontal Polarity (average)	1 – 18 GHz
Graph 11:	Horizontal Polarity (average)	18 – 24 GHz
Graph 12:	Horizontal Polarity (peak)	1 – 18 GHz
Graph 13:	Horizontal Polarity (peak)	18 – 24 GHz



Accredited for compliance with ISO/IEC 17025. The results of the tests, calibrations and/or measurements included in this document are traceable to Australian/national standards. NATA is a signatory to the ILAC Mutual Recognition Arrangement for the mutual recognition of the equivalence of testing, calibration and inspection reports.

This document shall not be reproduced except in full.

RADIATED EMI

Graph 1: Loop: Parallel 9 kHz – 30 MHz

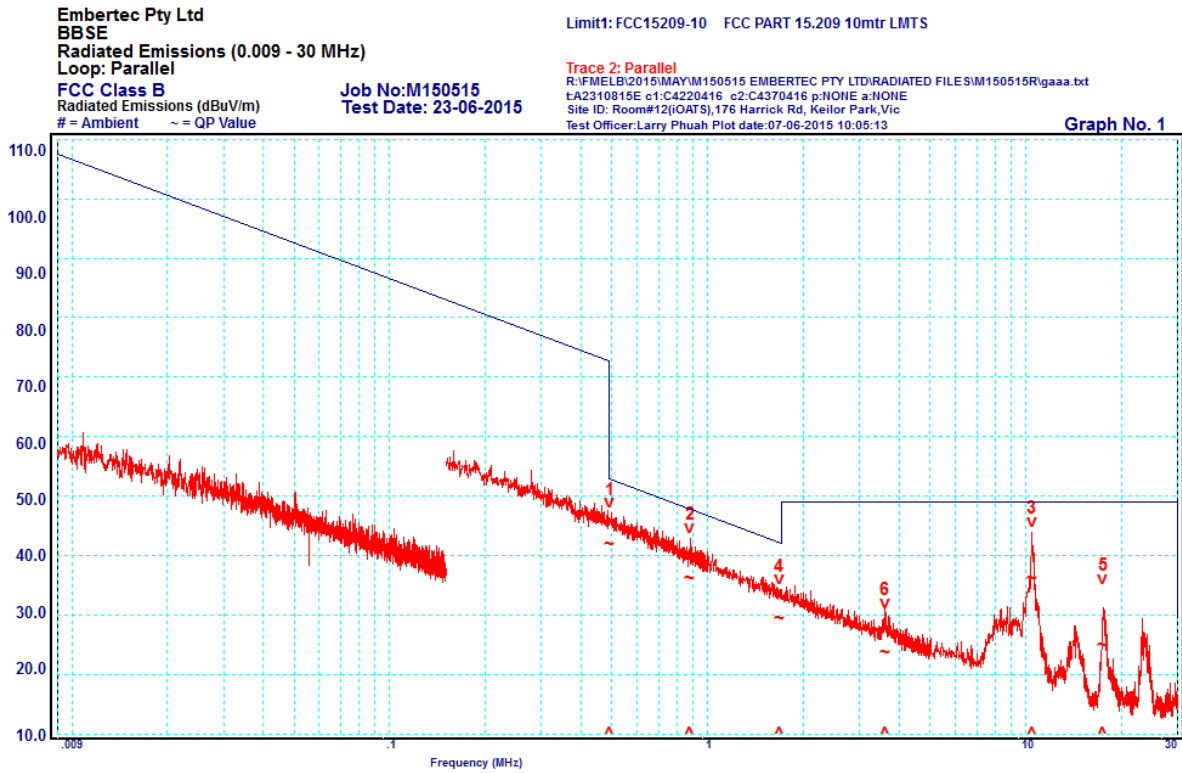

Peak	Frequency MHz	Polarisation	QP Measured dB μ V/m	QP Limit dB μ V/m	Δ QP \pm dB
1	0.492	Parallel	41.9	52.9	-11.0
2	0.881	Parallel	36.0	47.8	-11.8
3	10.45	Parallel	36.2	49.0	-12.8
4	1.680	Parallel	29.3	42.2	-12.9
5	17.52	Parallel	24.8	49.0	-24.2
6	3.603	Parallel	23.6	49.0	-25.4



Accredited for compliance with ISO/IEC 17025. The results of the tests, calibrations and/or measurements included in this document are traceable to Australian/national standards. NATA is a signatory to the ILAC Mutual Recognition Arrangement for the mutual recognition of the equivalence of testing, calibration and inspection reports.

This document shall not be reproduced except in full.

RADIATED EMI

Graph 2: Loop: Perpendicular 9 kHz – 30 MHz

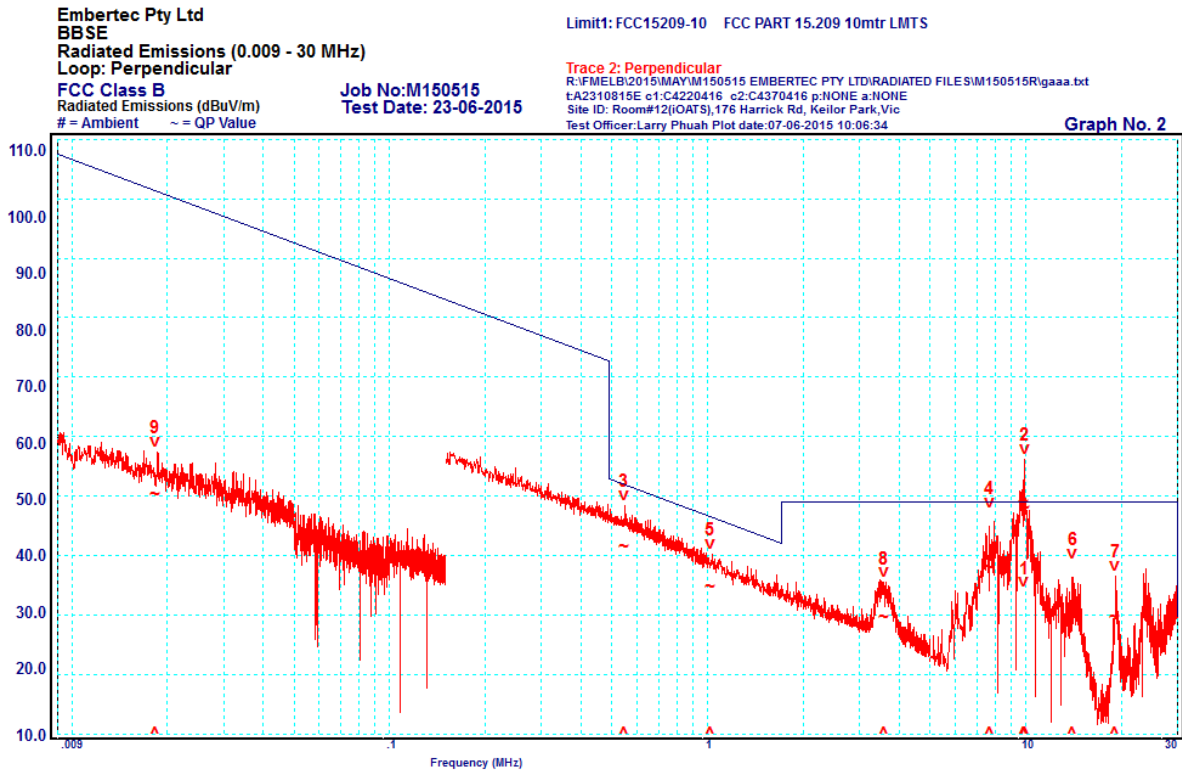

Peak	Frequency MHz	Polarisation	QP Measured dB μ V/m	QP Limit dB μ V/m	Δ QP \pm dB
1	9.865	Perpendicular	49.0	49.0	0.0
2	9.900	Perpendicular	48.0	49.0	-1.0
3	0.544	Perpendicular	41.4	52.0	-10.6
4	7.683	Perpendicular	37.9	49.0	-11.1
5	1.017	Perpendicular	34.6	46.6	-12.0
6	14.02	Perpendicular	29.7	49.0	-19.3
7	19.07	Perpendicular	29.6	49.0	-19.4
8	3.585	Perpendicular	29.5	49.0	-19.5
9	0.018	Perpendicular	50.3	101.4	-51.1



Accredited for compliance with ISO/IEC 17025. The results of the tests, calibrations and/or measurements included in this document are traceable to Australian/national standards. NATA is a signatory to the ILAC Mutual Recognition Arrangement for the mutual recognition of the equivalence of testing, calibration and inspection reports.

This document shall not be reproduced except in full.

RADIATED EMI

Graph 3: Loop: Z-Axis 9 kHz – 30 MHz

Embertec Pty Ltd
 BBSE
 Radiated Emissions (0.009 - 30 MHz)
 Loop: Z-Axis
 FCC Class B
 Radiated Emissions (dBuV/m)
 # = Ambient ~ = QP Value

Limit1: FCC15209-10 FCC PART 15.209 10mtr LMTS

Trace 2: Z-Axis
 R:\FMELB\2015\MAY\M150515 EMBERTEC PTY LTD\RADIATED FILES\M150515R\gaaa.txt
 t:A2310815E c1:C4220416 c2:C4370416 p:NONE a:NONE
 Site ID: Room#12(iOATS),176 Harrick Rd, Keilor Park, Vic
 Test Officer: Larry Phuah Plot date: 07-06-2015 10:52:58

Job No: M150515
 Test Date: 23-06-2015

Graph No. 3

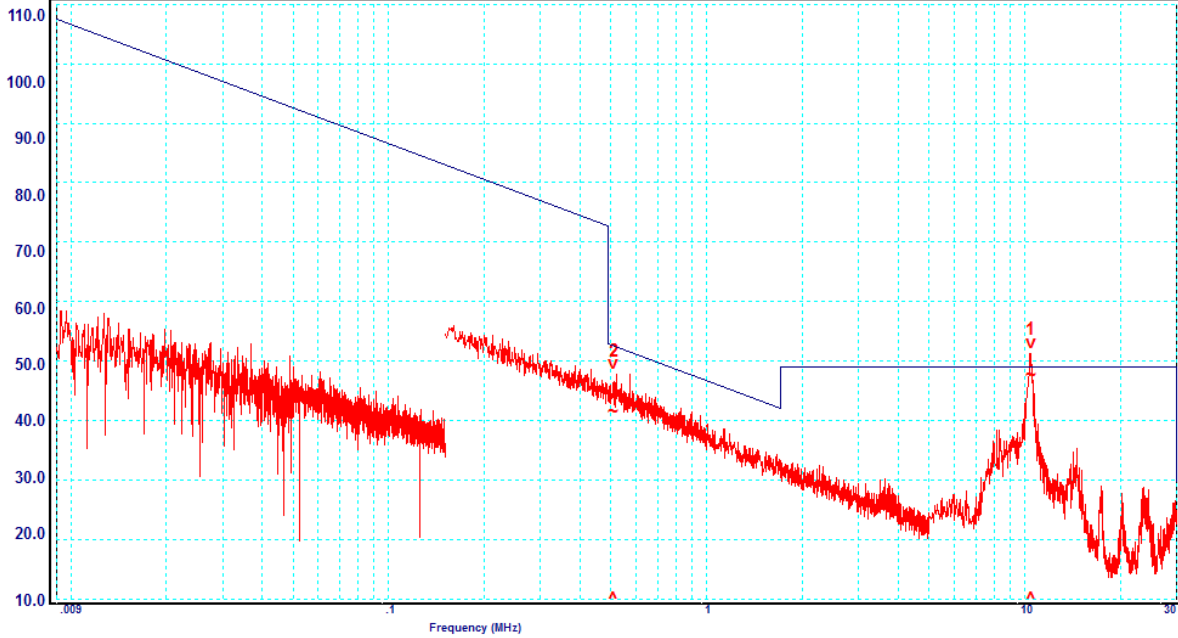

Peak	Frequency MHz	Polarisation	QP Measured dB μ V/m	QP Limit dB μ V/m	Δ QP \pm dB
1	10.46	Z-Axis	47.6	49.0	-1.4
2	0.510	Z-Axis	41.5	52.6	-11.1



Accredited for compliance with ISO/IEC 17025. The results of the tests, calibrations and/or measurements included in this document are traceable to Australian/national standards. NATA is a signatory to the ILAC Mutual Recognition Arrangement for the mutual recognition of the equivalence of testing, calibration and inspection reports.

This document shall not be reproduced except in full.

RADIATED EMI

Graph 4: Vertical Emissions 30 – 1000 MHz

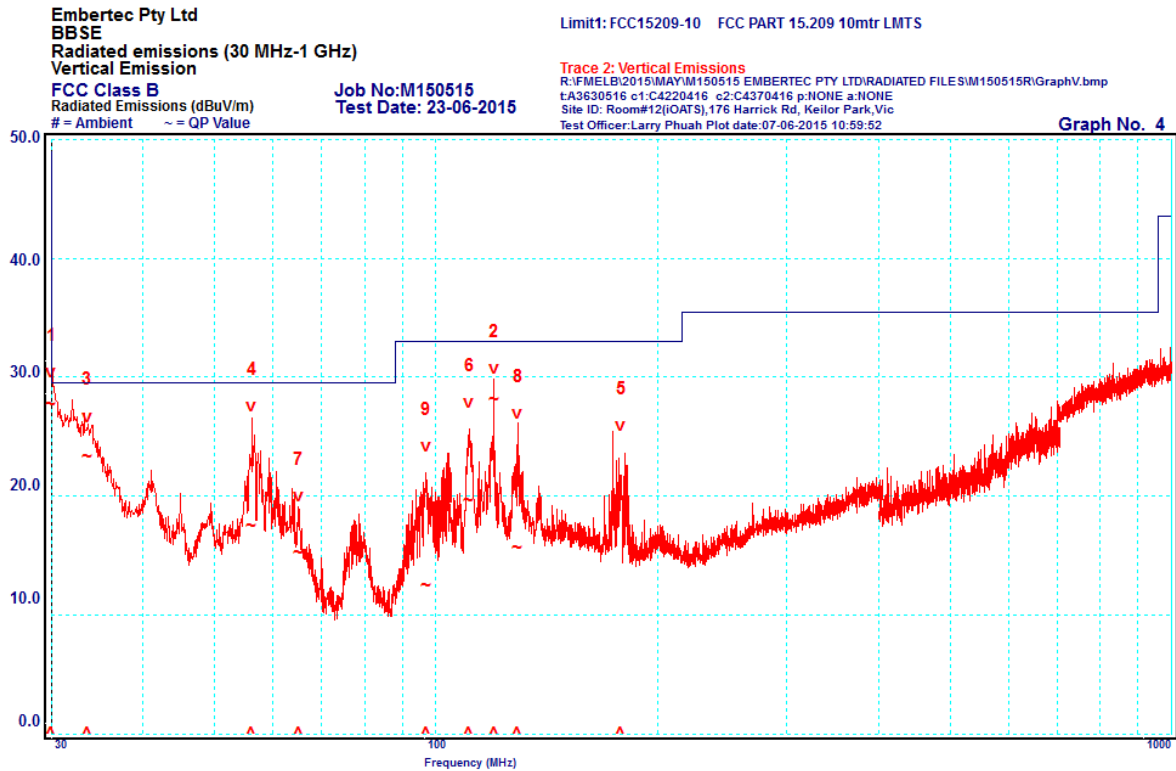

Peak	Frequency MHz	Polarisation	QP Measured dB μ V/m	QP Limit dB μ V/m	Δ QP \pm dB
1	30.040	Vertical	27.7	29.5	-1.8
2	120.01	Vertical	28.0	33.0	-5.0
3	33.600	Vertical	23.3	29.5	-6.2
4	56.240	Vertical	17.5	29.5	-12.0
5	178.51	Vertical	19.9	33.0	-13.1
6	111.06	Vertical	19.6	33.0	-13.4
7	65.010	Vertical	15.2	29.5	-14.3
8	129.27	Vertical	15.6	33.0	-17.4
9	97.000	Vertical	12.4	33.0	-20.6

RADIATED EMI

Graph 5: Horizontal Emissions 30 – 1000 MHz

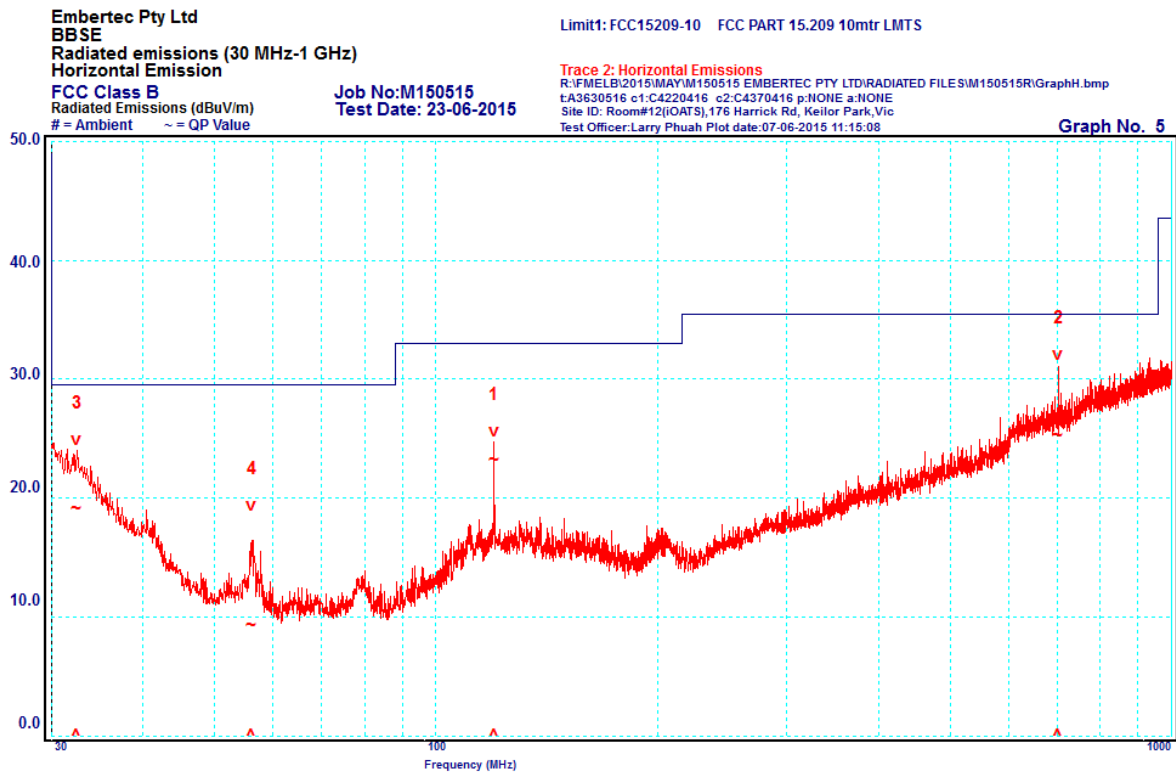

Peak	Frequency MHz	Polarisation	QP Measured dB μ V/m	QP Limit dB μ V/m	Δ QP \pm dB
1	120.00	Horizontal	23.2	33.0	-9.8
2	701.61	Horizontal	25.3	35.5	-10.2
3	32.520	Horizontal	19.1	29.5	-10.4
4	56.240	Horizontal	9.2	29.5	-20.3



Accredited for compliance with ISO/IEC 17025. The results of the tests, calibrations and/or measurements included in this document are traceable to Australian/national standards. NATA is a signatory to the ILAC Mutual Recognition Arrangement for the mutual recognition of the equivalence of testing, calibration and inspection reports.

This document shall not be reproduced except in full.

RADIATED EMI

Graph 6: Vertical Polarity (average) 1 – 18 GHz

Embertec Pty Ltd
 BBSE
 Radiated Emissions (1 - 18 GHz)
 Vertical Emissions (average)
 FCC Class B
 Radiated Emissions (dBuV/m)
 # = Ambient ~ = QP Value

Limit1: FCC15209Av FCC PART 15.209, 1-18GHz@3mtr, 18-40GHz@1mtr

Trace 2: Vertical Emissions
 R:\F\MELB\2015\MAY\M150515 EMBERTEC PTY LTD\RADIATED FILES\M150515G\GraphV.bmp
 LA2831115 c1:CAS10715 c2:NONE p:NONE a:NONE
 Site ID: Room#12(IQATS),176 Harrick Rd, Keilor Park, Vic
 Test Officer: Larry Phuah Plot date: 07-07-2015 11:01:38

Job No: M150515
 Test Date: 30-6-2015

Graph No. 6

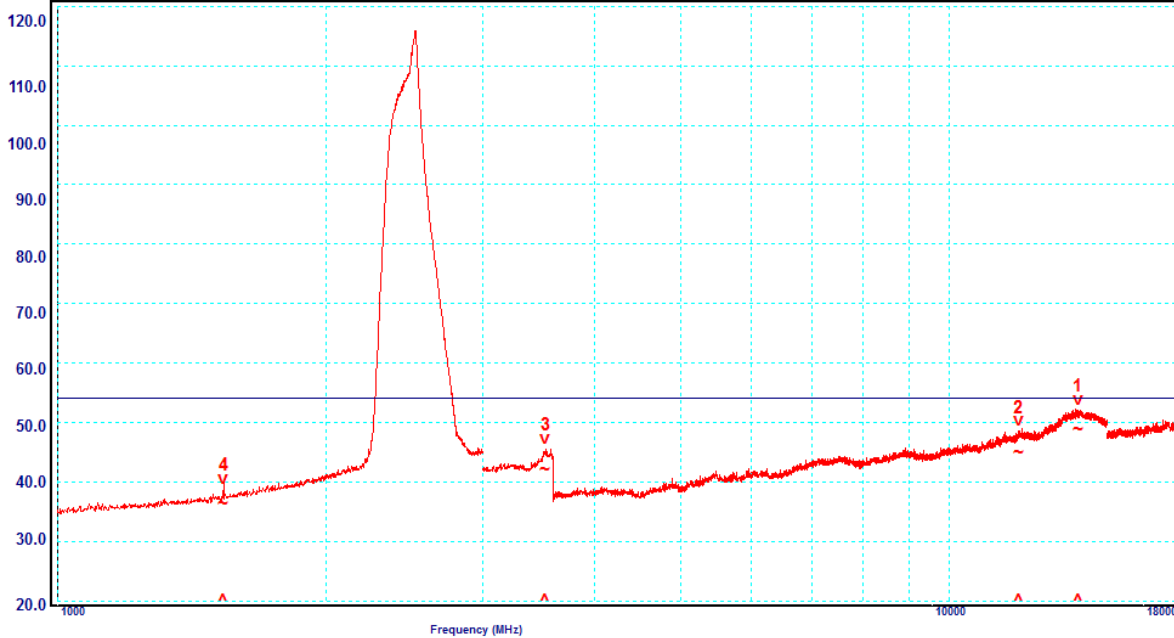

Peak	Frequency MHz	Polarisation	Measured AV Level dB μ V/m	AV Limit dB μ V/m	Δ AV \pm dB
1	13918.31	Vertical	48.7	54.0	-5.3
2	11947.63	Vertical	44.8	54.0	-9.2
3	3524.17	Vertical	42.0	54.0	-12.0
4	1535.96	Vertical	36.2	54.0	-17.8

*Notch filter included for 2.4GHz band



Accredited for compliance with ISO/IEC 17025. The results of the tests, calibrations and/or measurements included in this document are traceable to Australian/national standards. NATA is a signatory to the ILAC Mutual Recognition Arrangement for the mutual recognition of the equivalence of testing, calibration and inspection reports.

This document shall not be reproduced except in full.

RADIATED EMI

Graph 7: Vertical Polarity (average) 18 – 24 GHz

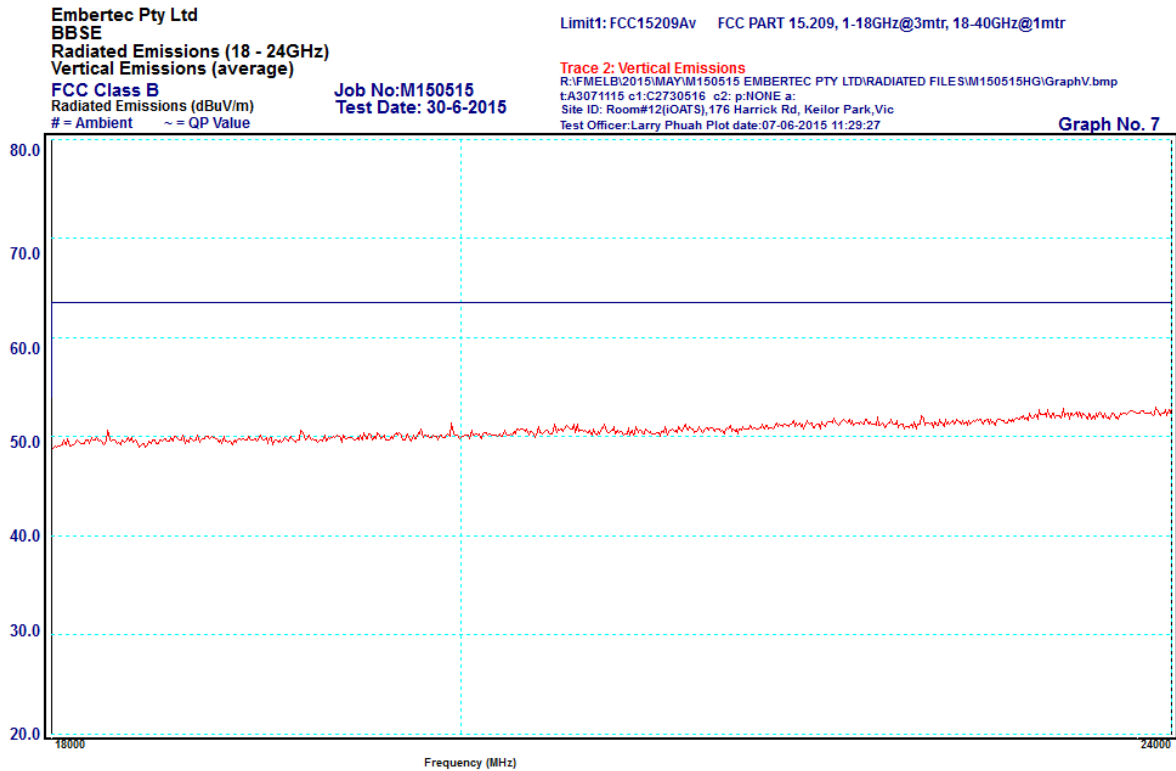

*No peaks were measured within 10 dB of the limit.

RADIATED EMI

Graph 8: Vertical Polarity (peak) 1 – 18 GHz

Embertec Pty Ltd
 BBSE
 Radiated Emissions (1 - 18 GHz)
 Vertical Emissions (peak)
 FCC Class B
 Radiated Emissions (dBuV/m)
 # = Ambient ~ = QP Value

Job No: M150515
 Test Date: 30-6-2015

Limit1: FCC15209Pk FCC PART 15.209, 1-18GHz@3mtr, 18-40GHz@1mtr

Trace 2: Vertical Emissions
 R:\F\MELB\2015\MAY\M150515 EMBERTEC PTY LTD\RADIATED FILES\M150515G\GraphV.bmp
 LA0040516 c1:CA610715 c2:NONE p:NONE a:NONE
 Site ID: Room#12(IQATS),176 Harrick Rd, Keilor Park, Vic
 Test Officer: Larry Phuah Plot date: 07-07-2015 11:06:08

Graph No. 8

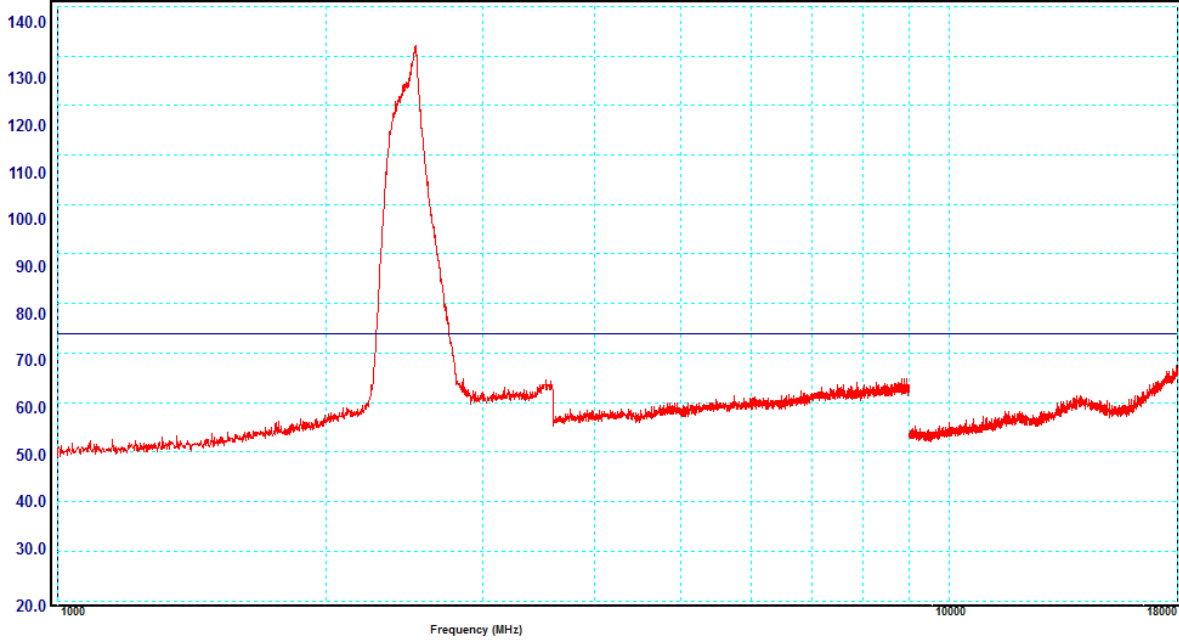

Peak	Frequency MHz	Polarisation	Measured PK Level dB μ V/m	PK Limit dB μ V/m	Δ PK \pm dB
1	2850.78	Vertical	64.9	74.0	-9.1
2	3530.25	Vertical	64.6	74.0	-9.4
3	3567.95	Vertical	64.4	74.0	-9.6
4	3504.84	Vertical	63.6	74.0	-10.4
5	3471.79	Vertical	63.5	74.0	-10.5
6	3168.28	Vertical	63.1	74.0	-10.9

*Notch filter included for 2.4GHz band



Accredited for compliance with ISO/IEC 17025. The results of the tests, calibrations and/or measurements included in this document are traceable to Australian/national standards. NATA is a signatory to the ILAC Mutual Recognition Arrangement for the mutual recognition of the equivalence of testing, calibration and inspection reports.

This document shall not be reproduced except in full.

RADIATED EMI

Graph 9: Vertical Polarity (peak) 18 – 24 GHz

Embertec Pty Ltd
 BBSE
 Radiated Emissions (18 - 24GHz)
 Vertical Emissions (peak)
 FCC Class B
 Radiated Emissions (dBuV/m)
 # = Ambient ~ = QP Value

Job No: M150515
 Test Date: 30-6-2015

Limit1: FCC15209Pk FCC PART 15.209, 1-18GHz@3mtr, 18-40GHz@1mtr

Trace 2: Vertical Emissions
 R:\F\MELB\2015\MAY\M150515 EMBERTEC PTY LTD\RADIATED FILES\M150515HG\GraphV.bmp
 LA3071115 c1:C2730516 c2: p:PHONE a:
 Site ID: Room#12(IQATS),176 Harrick Rd, Keilor Park, Vic
 Test Officer: Larry Phuah Plot date: 07-06-2015 11:37:07

Graph No. 9

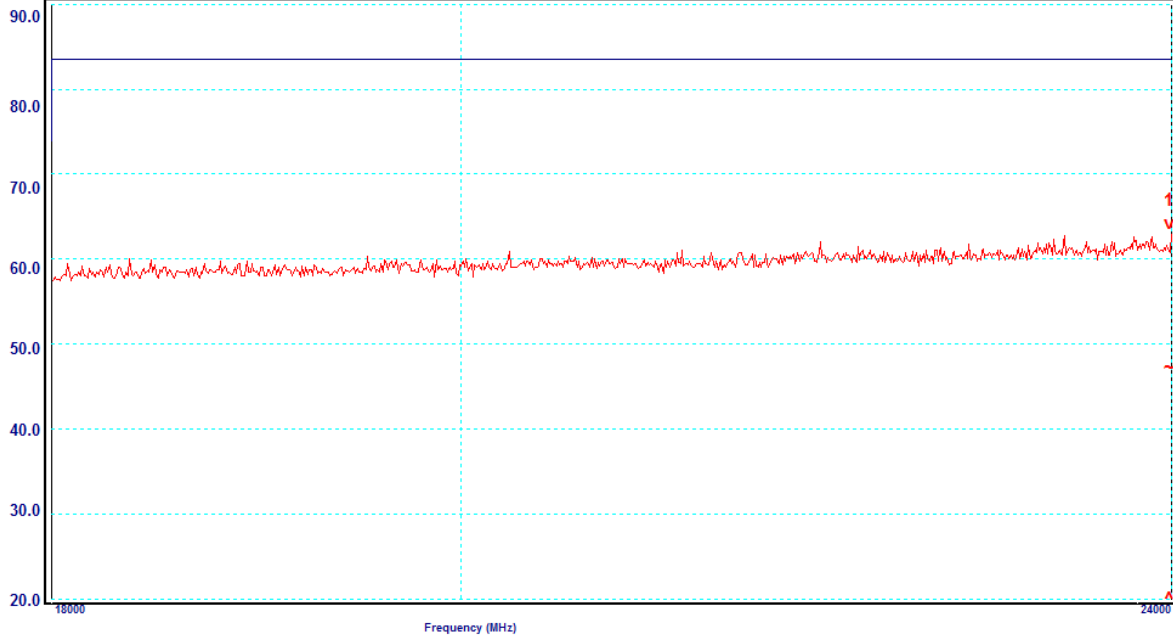

Peak	Frequency MHz	Polarisation	Measured PK Level dB μ V/m	PK Limit dB μ V/m	Δ PK \pm dB
1	23987.1	Vertical	63.0	83.5	-20.5



Accredited for compliance with ISO/IEC 17025. The results of the tests, calibrations and/or measurements included in this document are traceable to Australian/national standards. NATA is a signatory to the ILAC Mutual Recognition Arrangement for the mutual recognition of the equivalence of testing, calibration and inspection reports.

This document shall not be reproduced except in full.

RADIATED EMI

Graph 10: Horizontal Polarity (average) 1 – 18 GHz

Embertec Pty Ltd
 BBSE
 Radiated Emissions (1 - 18 GHz)
 Horizontal Emissions (average)
 FCC Class B
 Radiated Emissions (dBuV/m)
 # = Ambient ~ = QP Value

Limit1: FCC15209Av FCC PART 15.209, 1-18GHz@3mtr, 18-40GHz@1mtr

Trace 2: Horizontal Emissions
 R:\F\MELB\2015\MAY\M150515 EMBERTEC.PTY.LTD\RADIATED FILES\M150515G\GraphH.bmp
 LA2831115 c1:CAS10715 c2:NONE p:NONE a:NONE
 Site ID: Room#12(IQATS),176 Harrick Rd, Keilor Park, Vic
 Test Officer: Larry Phuah Plot date: 07-07-2015 11:20:19

Job No: M150515
 Test Date: 30-6-2015

Graph No. 10

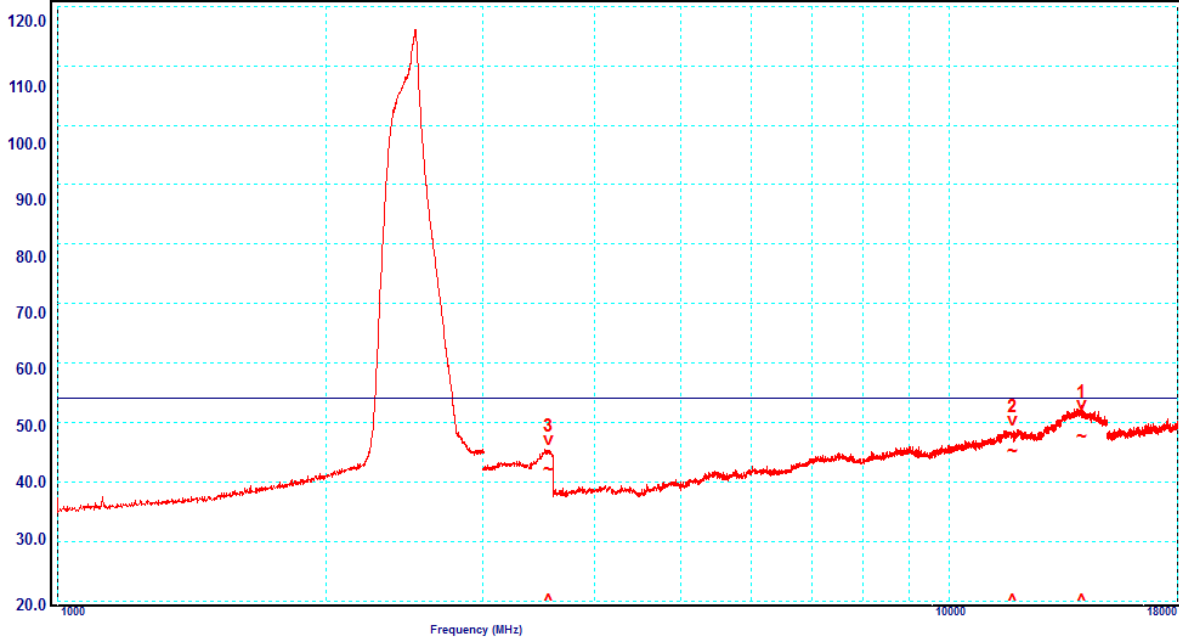

Peak	Frequency MHz	Polarisation	Measured AV Level dB μ V/m	AV Limit dB μ V/m	Δ AV \pm dB
1	14061.79	Horizontal	47.5	54.0	-6.5
2	11769.54	Horizontal	45.0	54.0	-9.0
3	3552.92	Horizontal	41.9	54.0	-12.1

*Notch filter included for 2.4GHz band



Accredited for compliance with ISO/IEC 17025. The results of the tests, calibrations and/or measurements included in this document are traceable to Australian/national standards. NATA is a signatory to the ILAC Mutual Recognition Arrangement for the mutual recognition of the equivalence of testing, calibration and inspection reports.

This document shall not be reproduced except in full.

RADIATED EMI

Graph 11: Horizontal Polarity (average) 18 – 24 GHz

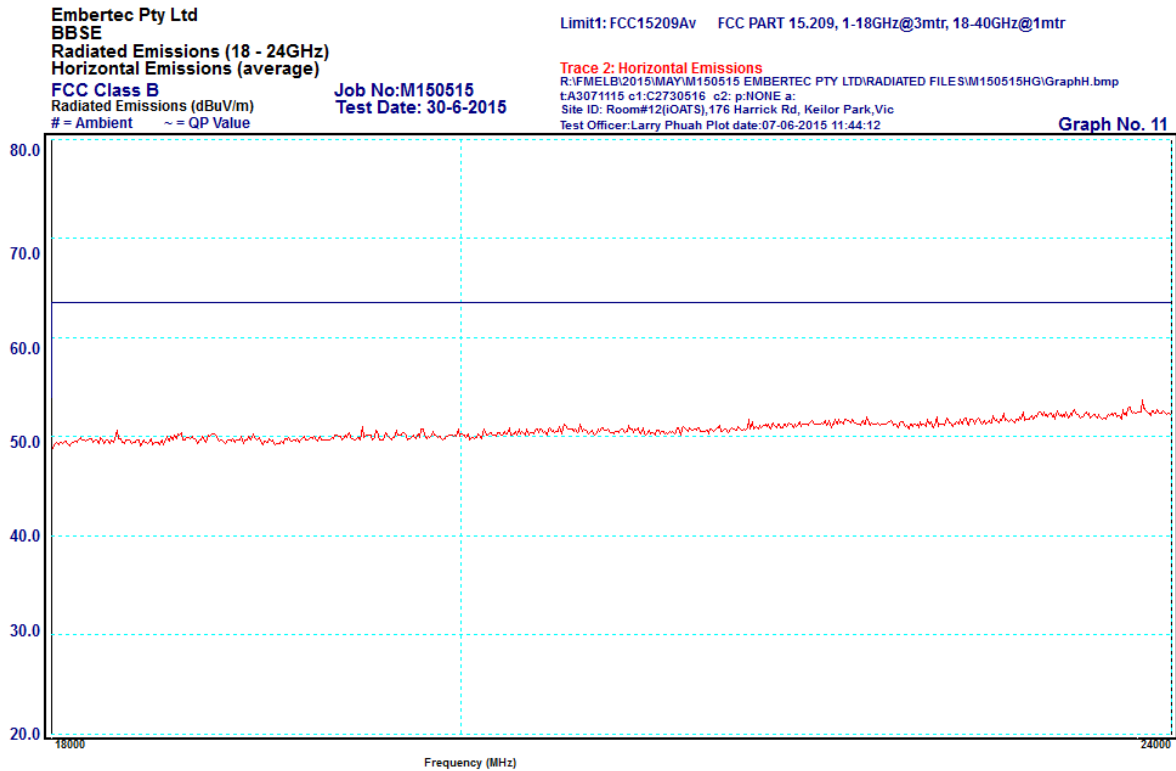

*No peaks were measured within 10 dB of the limit.



Accredited for compliance with ISO/IEC 17025. The results of the tests, calibrations and/or measurements included in this document are traceable to Australian/national standards. NATA is a signatory to the ILAC Mutual Recognition Arrangement for the mutual recognition of the equivalence of testing, calibration and inspection reports.

This document shall not be reproduced except in full.

RADIATED EMI

Graph 12: Horizontal Polarity (peak) 1 – 18 GHz

Embertec Pty Ltd
 BBSE
 Radiated Emissions (1 - 18 GHz)
 Horizontal Emissions (peak)
 FCC Class B
 Radiated Emissions (dBuV/m)
 # = Ambient ~ = QP Value

Job No: M150515
 Test Date: 30-6-2015

Limit1: FCC15209Pk FCC PART 15.209, 1-18GHz@3mtr, 18-40GHz@1mtr

Trace 2: Horizontal Emissions
 R:\F\MELB\2015\MAY\M150515 EMBERTEC PTY LTD\RADIATED FILES\M150515G\GraphH.bmp
 LA0040516 c1:CA610715 c2:NONE p:NONE a:NONE
 Site ID: Room#12(IQATS),176 Harrick Rd, Keilor Park, Vic
 Test Officer: Larry Phuah Plot date: 07-07-2015 11:23:22

Graph No. 12

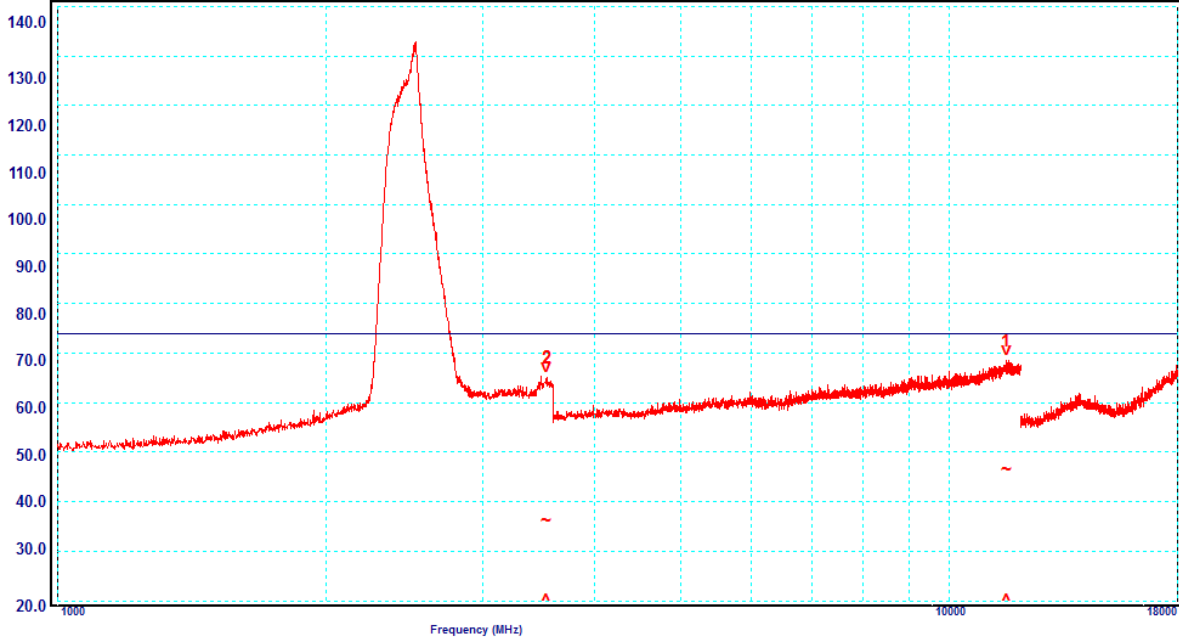

Peak	Frequency MHz	Polarisation	Measured PK Level dB μ V/m	PK Limit dB μ V/m	Δ PK \pm dB
1	11571.31	Horizontal	68.4	74.0	-5.6
2	3535.70	Horizontal	65.0	74.0	-9.0

*Notch filter included for 2.4GHz band



Accredited for compliance with ISO/IEC 17025. The results of the tests, calibrations and/or measurements included in this document are traceable to Australian/national standards. NATA is a signatory to the ILAC Mutual Recognition Arrangement for the mutual recognition of the equivalence of testing, calibration and inspection reports.

This document shall not be reproduced except in full.

RADIATED EMI

Graph 13: Horizontal Polarity (peak) 18 – 24 GHz

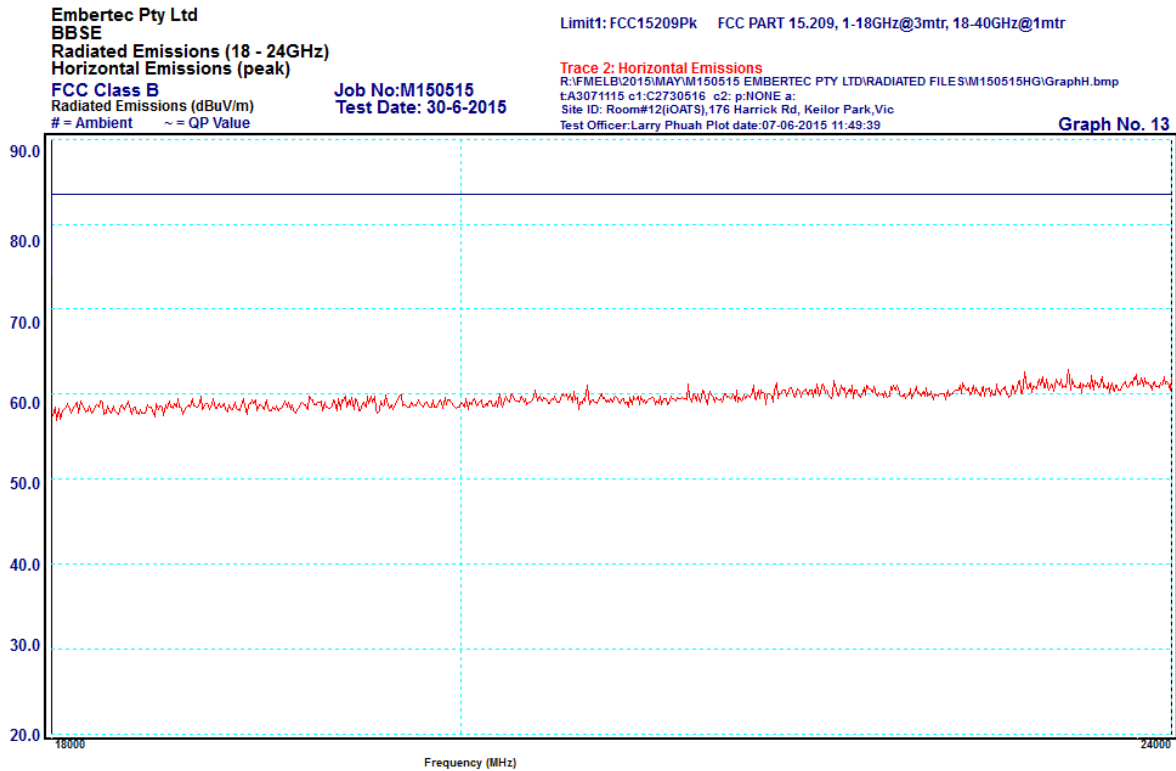

*No peaks were measured within 10 dB of the limit.