

TRaC Wireless Test Report : 9F2392WUS1

Applicant : Telegesis (UK) Ltd

Apparatus : ETRX351, ETRX351HR, ETRX357 and ETRX357HR
Radio Modules

Specification(s) : CFR47 Part 15.247 2008

FCCID : S4GEM35XA

Purpose of Test : Certification

Authorised by :



: Radio Product Manager

Issue Date : 19th March 2010

Authorised Copy Number : *PDF*

Contents

Section 1: Introduction	3
1.1 General	3
1.2 Tests Requested By	4
1.3 Manufacturer	4
1.4 Apparatus Assessed	5
1.5 Test Result Summary	6
1.6 Notes Relating To The Assessment	7
1.7 Deviations from Test Standards	7
Section 2: Measurement Uncertainty	8
2.1 Application of Measurement Uncertainty	8
2.2 Measurement Uncertainty Values	9
Section 3: Modifications	10
3.1 Modifications Performed During Assessment	10
Appendix A: Formal Emission Test Results	11
A1 6 dB Bandwidth	12
A2 Transmitter Peak Output Power	13
A3 Transmitter Power Spectral Density	14
A4 RF Antenna Conducted Spurious Emissions	15
A5 Radiated Electric Field Emissions within the Restricted Bands of 15.205	19
A6 Power Line Conducted Emissions	30
A7 Antenna Gain	33
A8 Unintentional Radiated Electric Field Emissions - 15.109	34
Appendix B: Supporting Graphical Data	43
Appendix C: Additional Test and Sample Details	72
Appendix D: Additional Information	78
Appendix E: Calculation of the duty cycle correction factor	96
Appendix E: Calculation of the duty cycle correction factor	96
Appendix F: Photographs and Figures	97
Appendix G: MPE Calculation	101

Section 1:**Introduction****1.1 General**

This report contains an assessment of an apparatus against Electromagnetic Compatibility Standards based upon tests carried out on samples submitted to the Laboratory.

Test performed at: TRaC Telecoms & Radio [X]
Unit E
South Orbital Trading Park
Hedon Road
Hull, HU9 1NJ.
United Kingdom.

Telephone: +44 (0) 1482 801801
Fax: +44 (0) 1482 801806

TRaC Telecoms & Radio [X]
Moss View
Nipe Lane
Up Holland
West Lancashire, WN8 9PY
United Kingdom

Telephone: +44 (0) 1695 556666
Fax: +44 (0) 1695 577077

Email: test@tracglobal.com
Web site: <http://www.tracglobal.com>

Tests performed by: K J Anderson
D Winstanley

Report author: K J Anderson

This report must not be reproduced except in full without prior written permission from TRaC Telecoms & Radio.

1.2 Tests Requested By

This testing in this report was requested by :

Telegesis (UK) Ltd
3 Abbey Barn Business Centre
Abbey Barn Lane
High Wycombe
Bucks
HP10 9QQ

1.3 Manufacturer

Ryder Electronics (Shenzhen) Ltd
139 Da Bao Road,
District 33 Bao An,
Shenzhen 518133
China

1.4 Apparatus Assessed

The following apparatus was assessed between 11/12/09 and 15/12/09:

ETRX357 Module
ETRX357HR Module

The ETRX357 is a Zigbee module fitted with an integral (Antenova Rufa 2.4GHz SMD) PCB mount antenna.

The ETRX357HR is a Zigbee module fitted with a Hirose U.FL connector for connection to an external antenna. The ETRX357HR can be supplied with either a $\lambda/4$ (EAD Ltd BT-Stubby Antenna) or $\lambda/2$ (Wellhope WH-2400-U2.5) external antenna.

All radiated testing was performed using all three antenna types, the conducted tests were performed using an ETRX357HR Module.

Datasheets for the three antennas are reproduced in Appendix D of this report

The family of products also include an ETRX351 series of modules that have identical RF circuitry to the ETRX357 range but with reduced on-board memory. No testing was performed on these modules. Details of the ETRX351 modules are contained within Appendix D of this report.

1.5 Test Result Summary

Full details of test results are contained within Appendix A. The following table summarises the results of the assessment.

The statements relating to compliance with the standards below apply ONLY as qualified in the notes and deviations stated in sections 1.6 to 1.7 of this test report.

Full details of test results are contained within Appendix A. The following table summarises the results of the assessment.

Test Type	Regulation	Measurement standard	Result
Radiated spurious emissions (Restricted bands)	Title 47 of the CFR: Part 15 Subpart C; 15.247	ANSI C63.10	Pass
Conducted spurious emissions (Non-restricted bands)	Title 47 of the CFR: Part 15 Subpart C; 15.247	ANSI C63.10	Pass
AC Power conducted emissions	Title 47 of the CFR: Part 15 Subpart C; 15.207	ANSI C63.10	Pass
Occupied Bandwidth	Title 47 of the CFR : Part 15 Subpart C; 15.247(a)(2)	ANSI C63.10	Pass
Conducted Carrier Power	Title 47 of the CFR : Part 15 Subpart C; 15.247(b)	ANSI C63.10	Pass
Power Spectral Density	Title 47 of the CFR : Part 15 Subpart C; 15.247(d)	ANSI C63.10	Pass
Unintentional Radiated Spurious Emissions	Title 47 of the CFR: Part 15 Subpart C; 15.109	ANSI C63.10	Pass
Digital Modulation	Title 47 of the CFR: Part 15 Subpart C; 15.403	-	Pass
RF Safety	Title 47 of the CFR : Part 15 Subpart C; 15.247(b)(5)	-	Pass

Abbreviations used in the above table:

Mod	: Modification	ANSI	: American National Standards Institution
CFR	: Code of Federal Regulations	PLCE	: Power Line Conducted Emissions
REFE	: Radiated Electric Field Emissions		

1.6 Notes Relating To The Assessment

With regard to this assessment, the following points should be noted:

The results contained in this report relate only to the items tested and were obtained in the period between the date of initial receipt of samples and the date of issue of the report.

The apparatus was set up and exercised using the configurations, modes of operation and arrangements defined in this report only.

Particular operating modes, apparatus monitoring methods and performance criteria required by the standards tested to have been performed except where identified in Section 1.7 of this test report (Deviations from Test Standards).

For emissions testing, throughout this test report, "Pass" indicates that the results for the sample as tested were below the specified limit (refer also to Section 2, Measurement Uncertainty).

Where relevant, the apparatus was only assessed using the monitoring methods and susceptibility criteria defined in this report.

All testing with the exception of testing at the Open Area Test Site was performed under the following environmental conditions:

Temperature	: 17 to 23 °C
Humidity	: 45 to 75 %
Barometric Pressure	: 86 to 106 kPa

All dates used in this report are in the format dd/mm/yy.

This assessment has been performed in accordance with the requirements of ISO/IEC 17025.

1.7 Deviations from Test Standards

There were no deviations from the standards tested to.

Section 2:

Measurement Uncertainty

2.1 Application of Measurement Uncertainty

The following table contains the measurement uncertainties for measurements

The following procedure is used when determining the result of a measurement :

- (i) If specification limits are not exceeded by the measured result, extended by the positive component of the expanded uncertainty interval at a confidence level of 95%, then a pass result is recorded.
- (ii) Where a specification limit is exceeded by the result even when the result is decreased by the negative component of the expanded uncertainty interval, a fail result is recorded.
- (iii) Where a measured result is below a limit, but by a margin less than the positive measurement uncertainty component, it is not possible to record a pass based on a 95% confidence level. However, the result indicates that a pass result is more probable than a fail result.
- (iv) Where a measured result is above a limit, but by a margin less than the negative measurement uncertainty component, it is not possible to record a fail based on a 95% confidence level. However the result indicates that a fail is more probable than a pass.

2.2 Measurement Uncertainty Values

For test data recorded in accordance with note (iii) of Section 2.1 the following measurement uncertainty was calculated:

Radiated Electric Field Emissions

Quantity Range	Quantity	Expanded Uncertainty
9kHz to 150 kHz	Amplitude dB(μ V/m)	± 1.6 dB
150 kHz to 30 MHz	Amplitude dB(μ V/m)	± 2.1 dB
30MHz to 300MHz Horizontal	Amplitude dB(μ V/m)	± 5.1 dB
30MHz to 300MHz Vertical	Amplitude dB(μ V/m)	± 5.2 dB
300MHz to 1GHz Horizontal	Amplitude dB(μ V/m)	± 5.4 dB
300MHz to 1GHz Vertical	Amplitude dB(μ V/m)	± 5.2 dB
1GHz to 18GHz Horizontal	Amplitude dB(μ V/m)	± 4.4 dB
1GHz to 18GHz Vertical	Amplitude dB(μ V/m)	± 4.4 dB
18GHz to 26.5GHz Horizontal	Amplitude dB(μ V/m)	± 4.2 dB
18GHz to 26.5GHz Vertical	Amplitude dB(μ V/m)	± 4.2 dB
26.5GHz to 40GHz Horizontal	Amplitude dB(μ V/m)	± 4.3 dB
26.5GHz to 40GHz Vertical	Amplitude dB(μ V/m)	± 4.3 dB

Power Line Conducted Emissions

Quantity Range	Quantity	Expanded Uncertainty
9kHz to 150kHz	Amplitude dB(μ V)	± 4.2 dB
150kHz to 30MHz	Amplitude dB(μ V)	± 3.1 dB

Section 3:

Modifications

3.1 Modifications Performed During Assessment

No modifications were performed during the assessment

Appendix A:

Formal Emission Test Results

Abbreviations used in the tables in this appendix:

Spec	: Specification	ALSR	: Absorber Lined Screened Room
Mod	: Modification	OATS	: Open Area Test Site
EUT	: Equipment Under Test	ATS	: Alternative Test Site
SE	: Support Equipment	Ref	: Reference
L	: Live Power Line	Freq	: Frequency
N	: Neutral Power Line	MD	: Measurement Distance
E	: Earth Power Line	SD	: Spec Distance
Pk	: Peak Detector	Pol	: Polarisation
QP	: Quasi-Peak Detector	H	: Horizontal Polarisation
Av	: Average Detector	V	: Vertical Polarisation
CDN	: Coupling & decoupling network		

A1 6 dB Bandwidth

Title 47 of the CFR: Part 15 Subpart (c) 15.247(a)(2) requires the measurement of the bandwidth of the transmission between the -6 dB points on the transmitted spectrum.

Test Details:	
Regulation	Title 47 of the CFR: Part 15 Subpart (c) 15.247(a)(2)
EUT sample number	S07
Modification state	0
SE in test environment	None
SE isolated from EUT	None
EUT set up	Refer to Appendix C

Channel Frequency (MHz)	F_{lower}	F_{Higher}	Measured 20 dB Bandwidth (kHz)	Limit (kHz)	Result
2405	2404.182	2405.785	1603	>500	Pass
2445	2444.182	2445.817	1635	>500	Pass
2480	2479.197	2480.785	1588	>500	Pass

Plots of the 6 dB bandwidth are contained in Appendix B of this test report.

A2 Transmitter Peak Output Power

Carrier power was verified with the EUT transmitting on its lowest, centre and highest carrier frequency in turn.

Test Details:	
Regulation	Title 47 of the CFR: Part15 Subpart (c) 15.247(b)(3)
Measurement standard	ANSI C63.10
EUT sample number	S07
Modification state	0
SE in test environment	None
SE isolated from EUT	None
EUT set up	Refer to Appendix C

Channel Frequency (MHz)	Peak Carrier Power (W)	Antenna Gain dBi	Radiated Power (W) (EIRP)	Limit (W)	Result
2405	0.0065	2.5	0.0117	1.0000	Pass
2445	0.0066	2.5	0.0119	1.0000	Pass
2480	0.00066	2.5	0.0012	1.0000	Pass

Notes:

Conducted Measurement

Measured Peak Carrier power includes highest gain of any antenna to be used.

Highest Gain of any antenna to be used = 2.5 dBi

Conducted measurements were performed with a temporary antenna connector provided by the client.

A3 Transmitter Power Spectral Density

Transmitter Power Spectral Density was verified with the EUT transmitting on its lowest, centre and highest carrier frequency in turn.

Test Details:	
Regulation	Title 47 of the CFR: Part15 Subpart (c) 15.247(e)
Measurement standard	ANSI C63.10
EUT sample number	S07
Modification state	0
SE in test environment	None
SE isolated from EUT	None
EUT set up	Refer to Appendix C

Channel Frequency (MHz)	Peak Power Spectral Density (dBm/3kHz)	Limit (dBm/3kHz)	Result
2405	-3.7	8.0	Pass
2445	-3.6	8.0	Pass
2480	-13.8	8.0	Pass

Notes:**Conducted Measurement**

Measured Power Spectral Density includes highest gain of any antenna to be used.

Highest Gain of any antenna to be used = 2.5 dBi

Conducted measurements were performed with a temporary antenna connector provided by the client.

The resolution bandwidth on the analyser was set to 3kHz and trace set to max hold.

The span is set to 1.5MHz

The sweep time is 500 seconds (Span/3kHz).

A4 RF Antenna Conducted Spurious Emissions

Measurement of conducted spurious emissions at the antenna port was performed using a peak detector with the RBW set to 100kHz and the VBW>RBW. Frequencies were scanned up through to the 10th harmonic with the EUT transmitting on its lowest, centre and highest carrier frequency in turn.

Test Details: 2405 MHz	
Regulation	Title 47 of the CFR: Part 15 Subpart (c) Clause 15.247(d) and Clause 15.205
Measurement standard	ANSI C63.10
Frequency range	9 kHz to 25 GHz
EUT sample number	S07
Modification state	0
SE in test environment	None
SE isolated from EUT	None
EUT set up	Refer to Appendix C

The worst case conducted emission measurements at the antenna port are listed below:

Ref No.	Measured Freq (MHz)	Det.	Is measured Frequency within the Restricted bands (Y/N)	Measured Peak Conducted power (RBW =100kHz) (dBuV)	15.247(d) Limit (dBuV)	Summary
1.	7208.333	Pk	N	67.7	91.6	Pass

No further emissions were detected within 20 dB of the test limit.

RF Antenna Conducted Spurious Emissions continued:

Test Details: 2445 MHz	
Regulation	Title 47 of the CFR: Part 15 Subpart (c) Clause 15.247(d) and Clause 15.205
Measurement standard	ANSI C63.10
Frequency range	9 kHz to 25 GHz
EUT sample number	S07
Modification state	0
SE in test environment	None
SE isolated from EUT	None
EUT set up	Refer to Appendix C

The worst case conducted emission measurements at the antenna port are listed below:

Ref No.	Measured Freq (MHz)	Det.	Is measured Frequency within the Restricted bands (Y/N)	Measured Peak Conducted power (RBW =100kHz) (dBuV)	15.247(d) Limit (dBuV)	Summary
1.	7333.333	Pk	N	67.5	91.7	Pass

No further emissions were detected within 20 dB of the test limit.

RF Antenna Conducted Spurious Emissions continued:

Test Details: 2480 MHz	
Regulation	Title 47 of the CFR: Part 15 Subpart (c) Clause 15.247(d) and Clause 15.205
Measurement standard	ANSI C63.10
Frequency range	9 kHz to 25 GHz
EUT sample number	S07
Modification state	0
SE in test environment	None
SE isolated from EUT	None
EUT set up	Refer to Appendix C

No emissions were detected within 20 dB of the test limit.

Notes:

1. The conducted emission limit for emissions outside the restricted bands, defined in 47CFR15.205(a) are based on a transmitted carrier level of 15.247(b). With the EUT transmitting on its lowest, centre and highest carrier frequencies in turn, emissions from the EUT are required to be 20 dB below the level of the highest fundamental as measured within a 100 kHz RBW in accordance with 15.247(d) using a peak detector.
2. The RBW = 100 kHz, Video bandwidth (VBW) > RBW and the radio spectrum was investigated up to the 10th harmonic in accordance 15.33 (a)(1).
3. The measurements at 2400 MHz and 2483.5 MHz were made to ensure band edge compliance.
4. The carrier level was measured whilst varying the supply voltage between 85% and 105% of the nominal supply voltage as required by 15.31(e). No variation in carrier level was observed. All other emissions were at least 20dB below the test limit

The limit outside the restricted band in 100 kHz RBW is defined using the following formula in accordance with 15.247(d):

The limit in 100 kHz RBW = (Maximum Peak Conducted Carrier measured in 100kHz RBW)-20dB

Where:

The maximum peak conducted power was measured using a spectrum analyser using a 100kHz resolution bandwidth.

Channel No.	Channel Frequency (MHz)	Measured Peak Carrier (dB μ V)	Measured Peak Carrier -20dB (dB μ V)	Emission Limit In a 100 kHz RBW (dB μ V)
11	2405	111.6	91.6	91.6
19	2445	111.7	91.7	91.7
26	2480	101.9	81.9	81.9

A5 Radiated Electric Field Emissions within the Restricted Bands of 15.205

Preliminary scans were performed using a peak detector with the RBW = 100kHz. The radiated electric field emission test applies to spurious emissions and harmonics that fall within the restricted bands listed in Section 15.205. The maximum permitted field strength is listed in Section 15.209. The EUT was set to transmit on its lowest, centre and highest carrier frequency.

The following test site was used for final measurements as specified by the standard tested to:

3m open area test site :



3m alternative test site :



The effect of the EUT set-up on the measurements is summarised in note (c) below.

Test Details: ETRX357 - 2405 MHz	
Regulation	Title 47 of the CFR: Part 15 Subpart (b) Clause 15.209
Measurement standard	ANSI C63.10
Frequency range	30MHz to 25 GHz
EUT sample number	S13
Modification state	0
SE in test environment	None
SE isolated from EUT	None
EUT set up	Refer to Appendix C
Photographs (Appendix F)	Photographs 1 and 2

The worst case radiated emission measurements for spurious emissions:

Ref No.	FREQ. (MHz)	DETECTOR	FIELD ST'GH (dB μ V/m)	EXTRAP FACT (dB)	FIELD ST'GH (dB μ V/m)	LIMIT (dB μ V/m)
1.	4808.993	Pk	51.7	0	51.7	74
2.	4808.993	Av	42.2	0	42.2	54
3.	7216.410	Pk	58.5	0	58.5	100.4
4.	7216.410	Av	50.2	0	50.2	80.4
5.	9617.914	Pk	54.2	0	54.2	100.4
6.	9617.914	Av	42.3	0	42.3	80.4

Test Details: ETRX357 - 2445 MHz	
Regulation	Title 47 of the CFR: Part 15 Subpart (b) Clause 15.209
Measurement standard	ANSI C63.10
Frequency range	30MHz to 25 GHz
EUT sample number	S13
Modification state	0
SE in test environment	None
SE isolated from EUT	None
EUT set up	Refer to Appendix C
Photographs (Appendix F)	Photographs 1 and 2

The worst case radiated emission measurements for spurious emissions:

Ref No.	FREQ. (MHz)	DETECTOR	FIELD ST'GH (dB μ V/m)	EXTRAP FACT (dB)	FIELD ST'GH (dB μ V/m)	LIMIT (dB μ V/m)
1.	4890.961	Pk	54.2	0	54.2	74.0
2.	4890.961	Av	46.3	0	46.3	54.0
3.	7333.657	Pk	55.6	0	55.6	74.0
4.	7333.657	Av	46.5	0	46.5	54.0
5.	9778.125	Pk	52.0	0	52.0	99.0
6.	9778.125	Av	39.5	0	39.5	79.0

Test Details: ETRX357 - 2480 MHz	
Regulation	Title 47 of the CFR: Part 15 Subpart (b) Clause 15.209
Measurement standard	ANSI C63.10
Frequency range	30MHz to 25 GHz
EUT sample number	S13
Modification state	0
SE in test environment	None
SE isolated from EUT	None
EUT set up	Refer to Appendix C
Photographs (Appendix F)	Photographs 1 and 2

The worst case radiated emission measurements for spurious emissions:

Ref No.	FREQ. (MHz)	DETECTOR	FIELD ST'GH (dB μ V/m)	EXTRAP FACT (dB)	FIELD ST'GH (dB μ V/m)	LIMIT (dB μ V/m)
1.	4959.158	Pk	51.2	0	51.2	74.0
2.	4959.158	Av	41.7	0	41.7	54.0

Test Details: ETRX357 HR Option 1 - 2405 MHz	
Regulation	Title 47 of the CFR: Part 15 Subpart (b) Clause 15.209
Measurement standard	ANSI C63.10
Frequency range	30MHz to 25 GHz
EUT sample number	S04
Modification state	0
SE in test environment	None
SE isolated from EUT	None
EUT set up	Refer to Appendix C
Photographs (Appendix F)	Photographs 1 and 2

The worst case radiated emission measurements for spurious emissions:

Ref No.	FREQ. (MHz)	DETECTOR	FIELD ST'GH (dB μ V/m)	EXTRAP FACT (dB)	FIELD ST'GH (dB μ V/m)	LIMIT (dB μ V/m)
1.	4808.990	Pk	60.8	0	60.8	74.0
2.	4808.990	Av	52.0	0	52.0	54.0
3.	7216.298	Pk	60.9	0	60.9	102.0
4.	7216.298	Av	53.5	0	53.5	82.0
5.	9617.964	Pk	54.9	0	54.9	102.0
6.	9617.964	Av	44.3	0	44.3	82.0

Test Details: ETRX357 HR Option 1 - 2445 MHz	
Regulation	Title 47 of the CFR: Part 15 Subpart (b) Clause 15.209
Measurement standard	ANSI C63.10
Frequency range	30MHz to 25 GHz
EUT sample number	S04
Modification state	0
SE in test environment	None
SE isolated from EUT	None
EUT set up	Refer to Appendix C
Photographs (Appendix F)	Photographs 1 and 2

The worst case radiated emission measurements for spurious emissions:

Ref No.	FREQ. (MHz)	DETECTOR	FIELD ST'GH (dB μ V/m)	EXTRAP FACT (dB)	FIELD ST'GH (dB μ V/m)	LIMIT (dB μ V/m)
1.	4889.038	Pk	56.9	0	56.9	74.0
2.	4889.038	Av	49.5	0	49.5	54.0
3.	7333.397	Pk	63.4	0	63.4	74.0
4.	7333.397	Av	55.9	0	55.9	54.0
5.	9778.948	Pk	52.8	0	52.8	102.3
6.	9778.948	Av	39.7	0	39.7	82.3

Test Details: ETRX357 HR Option 1 - 2480 MHz	
Regulation	Title 47 of the CFR: Part 15 Subpart (b) Clause 15.209
Measurement standard	ANSI C63.10
Frequency range	30MHz to 25 GHz
EUT sample number	S04
Modification state	0
SE in test environment	None
SE isolated from EUT	None
EUT set up	Refer to Appendix C
Photographs (Appendix F)	Photographs 1 and 2

The worst case radiated emission measurements for spurious emissions:

Ref No.	FREQ. (MHz)	DETECTOR	FIELD ST'GH (dB μ V/m)	EXTRAP FACT (dB)	FIELD ST'GH (dB μ V/m)	LIMIT (dB μ V/m)
1.	4959.158	Pk	53.1	0	53.1	74.0
2.	4959.158	Av	43.1	0	43.1	54.0

Test Details: ETRX357 HR Option 2 - 2405 MHz	
Regulation	Title 47 of the CFR: Part 15 Subpart (b) Clause 15.209
Measurement standard	ANSI C63.10
Frequency range	30MHz to 25 GHz
EUT sample number	S04
Modification state	0
SE in test environment	None
SE isolated from EUT	None
EUT set up	Refer to Appendix C
Photographs (Appendix F)	Photographs 1 and 2

The worst case radiated emission measurements for spurious emissions:

Ref No.	FREQ. (MHz)	DETECTOR	FIELD ST'GH (dB μ V/m)	EXTRAP FACT (dB)	FIELD ST'GH (dB μ V/m)	LIMIT (dB μ V/m)
1.	4808.990	Pk	54.1	0	54.1	74.0
2.	4808.990	Av	46.1	0	46.1	54.0
3.	7213.477	Pk	62.8	0	62.8	99.9
4.	7213.477	Av	55.4	0	55.4	79.9
5.	9617.964	Pk	54.0	0	54.0	99.9
6.	9617.964	Av	43.4	0	43.4	79.9

Test Details: ETRX357 HR Option 2 - 2445 MHz	
Regulation	Title 47 of the CFR: Part 15 Subpart (b) Clause 15.209
Measurement standard	ANSI C63.10
Frequency range	30MHz to 25 GHz
EUT sample number	S04
Modification state	0
SE in test environment	None
SE isolated from EUT	None
EUT set up	Refer to Appendix C
Photographs (Appendix F)	Photographs 1 and 2

The worst case radiated emission measurements for spurious emissions:

Ref No.	FREQ. (MHz)	DETECTOR	FIELD ST'GH (dB μ V/m)	EXTRAP FACT (dB)	FIELD ST'GH (dB μ V/m)	LIMIT (dB μ V/m)
1.	4890.993	Pk	55.4	0	55.4	74.0
2.	4890.993	Av	47.7	0	47.7	54.0
3.	7336.442	Pk	65.5	0	65.5	74.0
4.	7336.442	Av	58.2	0	58.2	54.0
5.	9778.884	Pk	54.5	0	54.5	104.0
6.	9778.884	Av	43.5	0	43.5	84.0

Test Details: ETRX357 HR Option 2 - 2480 MHz	
Regulation	Title 47 of the CFR: Part 15 Subpart (b) Clause 15.209
Measurement standard	ANSI C63.10
Frequency range	30MHz to 25 GHz
EUT sample number	S04
Modification state	0
SE in test environment	None
SE isolated from EUT	None
EUT set up	Refer to Appendix C
Photographs (Appendix F)	Photographs 1 and 2

The worst case radiated emission measurements for spurious emissions:

Ref No.	FREQ. (MHz)	DETECTOR	FIELD ST'GH (dB μ V/m)	EXTRAP FACT (dB)	FIELD ST'GH (dB μ V/m)	LIMIT (dB μ V/m)
1.	4960.954	Pk	52.4	0	53.1	74.0
2.	4960.954	Av	43.5	0	43.1	54.0

Notes:

- Any testing performed below 30 MHz was performed using a magnetic loop antenna in accordance with ANSI C63.10: section 4.5, Table 1
- In accordance with 15.35(b), above 1 GHz, emissions measured using a peak detector shall not exceed a level 20 dB above the average limit.
- For all the above tables, the average emissions results can be reduced by the 11.4 dB duty cycle correction factor calculated in Appendix E for comparison with the test limit.
- Testing was performed with the EUT orientated in three orthogonal planes and the maximum emissions level recorded. In addition, the EUT antenna was varied within its range of motion in order to maximise emissions.
- For Frequencies below 1 GHz, RBW= 100 kHz, testing was performed with CISPR16 compliant test receiver with QP detector. Above 1 GHz tests were performed using a spectrum analyser using the following settings:

Peak	RBW=VBW= 1MHz
Average	RBW=VBW= 1MHz

These settings as per ANSI C63.10

The upper and lower frequency of the measurement range was decided according to 47 CFR 15:2008 Clause 15.33(a) and 15.33(a)(1).

Radiated emission limits (47 CFR 15: Clause 15.209) for emissions falling within the restricted bands defined in 15.205(a):

Frequency of emission (MHz)	Field strength $\mu\text{V/m}$	Measurement Distance m	Field strength $\text{dB}\mu\text{V/m}$
0.009-0.490	2400/F(kHz)	300	67.6/F (kHz)
0.490-1.705	24000/F(kHz)	30	87.6/F (kHz)
1.705-30	30	30	29.5
30-88	100	3	40.0
88-216	150	3	43.5
216-960	200	3	46.0
Above 960	500	3	54.0

Notes:

- (a) Where results have been measured at one distance, and a signal level displayed at another, the results have been extrapolated using the following formula:

$$\text{Extrapolation (dB)} = 20 \log_{10} \left(\frac{\text{measurement distance}}{\text{specification distance}} \right)$$

The results displayed take into account applicable antenna factors and cable losses.

- (b) The levels may have been rounded for display purposes.
- (c) The following table summarises the effect of the EUT operating mode, internal configuration and arrangement of cables / samples on the measured emission levels :

	See (i)	See (ii)	See (iii)	See (iv)
Effect of EUT operating mode on emission levels		✓		
Effect of EUT internal configuration on emission levels		✓		
Effect of Position of EUT cables & samples on emission levels	✓			
(i) Parameter defined by standard and / or single possible, refer to Appendix D (ii) Parameter defined by client and / or single possible, refer to Appendix D (iii) Parameter had a negligible effect on emission levels, refer to Appendix D (iv) Worst case determined by initial measurement, refer to Appendix D				

A6 Power Line Conducted Emissions

Preview power line conducted emission measurements were performed with a peak detector in a screened room. The effect of the EUT set-up on the measurements is summarised in note (b). Where applicable formal measurements of the emissions were performed with a peak, average and/or quasi peak detector. The EUT was set to transmit on its lowest, centre and highest carrier frequency in turn. The formal measurements are detailed below:

Test Details: Transmit mode	
Regulation	Title 47 of the CFR: Part 15 Subpart (c) Clause 15.207
Measurement standard	ANSI C63.10
Frequency range	150kHz to 30MHz
EUT sample number	S04
Modification state	0
SE in test environment	Laptop
SE isolated from EUT	None
EUT set up	Refer to Appendix C
Photographs (Appendix F)	Photograph 3

The worst-case power line conducted emission measurements are listed below:

Results measured using the average detector compared to the average limit

Ref No.	Freq (MHz)	Conductor	Result (dBuV)	Spec Limit (dBuV)	Margin (dB)	Result Summary
1	0.150	L	38.4	66.0	-27.6	Pass
2	0.195	L	35.5	63.8	-28.3	Pass
3	12.000	L	39.0	60.0	-21.0	Pass
4	0.150	N	49.0	66.0	-17.0	Pass
5	0.200	N	46.5	63.6	-17.1	Pass
6	0.230	N	43.9	62.5	-18.6	Pass
7	11.195	N	42.2	60.0	-17.8	Pass
8	21.84	N	42.1	60.0	-17.9	Pass
9	25.635	N	46.0	60.0	-14	Pass

Results measured using the quasi-peak detector compared to the quasi-peak limit

Ref No.	Freq (MHz)	Conductor	Result (dBuV)	Spec Limit (dBuV)	Margin (dB)	Result Summary
1	12.000	L	35.3	50.0	-14.7	Pass
2	12.000	N	35.0	50.0	-15.0	Pass

Test Details: Receive mode	
Regulation	Title 47 of the CFR: Part 15 Subpart (c) Clause 15.207
Measurement standard	ANSI C63.10
Frequency range	150kHz to 30MHz
EUT sample number	S03
Modification state	0
SE in test environment	Laptop
SE isolated from EUT	None
EUT set up	Refer to Appendix C
Photographs (Appendix F)	Photograph 3

The worst-case power line conducted emission measurements are listed below:

Results measured using the average detector compared to the average limit

Ref No.	Freq (MHz)	Conductor	Result (dBuV)	Spec Limit (dBuV)	Margin (dB)	Result Summary
1	0.150	L	38.2	66.0	-27.8	Pass
2	0.200	L	35.1	63.6	-28.5	Pass
3	12.000	L	45.1	60.0	-14.9	Pass
4	0.150	N	40.4	66.0	-25.6	Pass
5	0.200	N	38.0	63.6	-25.6	Pass
6	0.280	N	35.2	60.8	-25.6	Pass
7	0.420	N	35.5	57.5	-22.0	Pass
8	1.770	N	1.0	56.0	-55.0	Pass
9	12.000	N	44.9	60.0	-15.1	Pass

Results measured using the quasi-peak detector compared to the quasi-peak limit

Ref No.	Freq (MHz)	Conductor	Result (dBuV)	Spec Limit (dBuV)	Margin (dB)	Result Summary
1	12.000	L	42.4	50.0	-7.6	Pass
2	14.290	L	30.6	50.0	-19.4	Pass
3	12.000	N	41.7	50.0	-8.3	Pass
4	14.290	N	30.1	50.0	-19.9	Pass

Specification limits :

Conducted emission limits (47 CFR 15: Clause 15.207):

Conducted disturbance at the mains ports.

Frequency range MHz	Limits dB μ V	
	Quasi-peak	Average
0.15 to 0.5	66 to 56 ²	56 to 46 ²
0.5 to 5	56	46
5 to 30	60	50

Notes:

1. The lower limit shall apply at the transition frequency.
2. The limit decreases linearly with the logarithm of the frequency in the range 0.15MHz to 0.5MHz.

Notes:

- (a) The levels may have been rounded for display purposes.
- (b) The following table summarises the effect of the EUT operating mode and internal configuration on the measured emission levels :

	See (i)	See (ii)	See (iii)	See (iv)
Effect of EUT operating mode on emission levels		✓		
Effect of EUT internal configuration on emission levels		✓		
(i) Parameter defined by standard and / or single possible, refer to Appendix C (ii) Parameter defined by client and / or single possible, refer to Appendix C (iii) Parameter had a negligible effect on emission levels, refer to Appendix C (iv) Worst case determined by initial measurement, refer to Appendix C				

A7 Antenna Gain

The maximum antenna gain for the antenna types to be used with the EUT, as declared by the client, is 2.5 dBi. (see Appendix D for data sheets for the three antenna options)

A8 Unintentional Radiated Electric Field Emissions - 15.109

Preliminary scans were performed using a peak detector with the RBW = 100kHz. The maximum permitted field strength is listed in Section 15.109. The EUT was set to receive mode only on its lowest, centre and highest carrier frequency in turn.

The following test site was used for final measurements as specified by the standard tested to :

3m open area test site : 3m alternative test site :

Test Details: ETRX357 - 2405 MHz	
Regulation	Title 47 of the CFR: Part 15 Subpart (b) Clause 15.109
Measurement standard	ANSI C63.10
Frequency range	30MHz to 25 GHz
EUT sample number	S13
Modification state	0
SE in test environment	None
SE isolated from EUT	None
EUT set up	Refer to Appendix C
Photographs (Appendix F)	Photographs 1 and 2

No Spurious emissions within 20 dB of the test limit were detected.

Test Details: ETRX357 - 2445 MHz	
Regulation	Title 47 of the CFR: Part 15 Subpart (b) Clause 15.109
Measurement standard	ANSI C63.10
Frequency range	30MHz to 25 GHz
EUT sample number	S13
Modification state	0
SE in test environment	None
SE isolated from EUT	None
EUT set up	Refer to Appendix C
Photographs (Appendix F)	Photographs 1 and 2

No Spurious emissions within 20 dB of the test limit were detected.

Test Details: ETRX357 - 2480 MHz	
Regulation	Title 47 of the CFR: Part 15 Subpart (b) Clause 15.109
Measurement standard	ANSI C63.10
Frequency range	30MHz to 25 GHz
EUT sample number	S13
Modification state	0
SE in test environment	None
SE isolated from EUT	None
EUT set up	Refer to Appendix C
Photographs (Appendix F)	Photographs 1 and 2

No Spurious emissions within 20 dB of the test limit were detected.

Test Details: ETRX357 HR Option 1 - 2405 MHz	
Regulation	Title 47 of the CFR: Part 15 Subpart (b) Clause 15.109
Measurement standard	ANSI C63.10
Frequency range	30MHz to 25 GHz
EUT sample number	S04
Modification state	0
SE in test environment	None
SE isolated from EUT	None
EUT set up	Refer to Appendix C
Photographs (Appendix F)	Photographs 1 and 2

No Spurious emissions within 20 dB of the test limit were detected.

Test Details: ETRX357 HR Option 1 - 2445 MHz	
Regulation	Title 47 of the CFR: Part 15 Subpart (b) Clause 15.109
Measurement standard	ANSI C63.10
Frequency range	30MHz to 25 GHz
EUT sample number	S04
Modification state	0
SE in test environment	None
SE isolated from EUT	None
EUT set up	Refer to Appendix C
Photographs (Appendix F)	Photographs 1 and 2

No Spurious emissions within 20 dB of the test limit were detected.

Test Details: ETRX357 HR Option 1 - 2480 MHz	
Regulation	Title 47 of the CFR: Part 15 Subpart (b) Clause 15.109
Measurement standard	ANSI C63.10
Frequency range	30MHz to 25 GHz
EUT sample number	S04
Modification state	0
SE in test environment	None
SE isolated from EUT	None
EUT set up	Refer to Appendix C
Photographs (Appendix F)	Photographs 1 and 2

No Spurious emissions within 20 dB of the test limit were detected.

Test Details: ETRX357 HR Option 2 - 2405 MHz	
Regulation	Title 47 of the CFR: Part 15 Subpart (b) Clause 15.109
Measurement standard	ANSI C63.10
Frequency range	30MHz to 25 GHz
EUT sample number	S04
Modification state	0
SE in test environment	None
SE isolated from EUT	None
EUT set up	Refer to Appendix C
Photographs (Appendix F)	Photographs 1 and 2

No Spurious emissions within 20 dB of the test limit were detected.

Test Details: ETRX357 HR Option 2 - 2445 MHz	
Regulation	Title 47 of the CFR: Part 15 Subpart (b) Clause 15.109
Measurement standard	ANSI C63.10
Frequency range	30MHz to 25 GHz
EUT sample number	S04
Modification state	0
SE in test environment	None
SE isolated from EUT	None
EUT set up	Refer to Appendix C
Photographs (Appendix F)	Photographs 1 and 2

No Spurious emissions within 20 dB of the test limit were detected.

Test Details: ETRX357 HR Option 2 - 2480 MHz	
Regulation	Title 47 of the CFR: Part 15 Subpart (b) Clause 15.109
Measurement standard	ANSI C63.10
Frequency range	30MHz to 25 GHz
EUT sample number	S04
Modification state	0
SE in test environment	None
SE isolated from EUT	None
EUT set up	Refer to Appendix C
Photographs (Appendix F)	Photographs 1 and 2

No Spurious emissions within 20 dB of the test limit were detected.

Appendix B:

Supporting Graphical Data

This appendix contains graphical data obtained during testing.

Notes:

- (a) The radiated electric field emissions and conducted emissions graphical data in this appendix is preview data. For details of formal results, refer to Appendix A and Appendix B.
- (b) The time and date on the plots do not necessarily equate to the time of the test.
- (c) Where relevant, on power line conducted emission plots, the limit displayed is the average limit, which is stricter than the quasi peak limit.
- (d) Appendix C details the numbering system used to identify the sample and its modification state.
- (e) The plots presented in this appendix may not be a complete record of the measurements performed, but are a representative sample, relative to the final assessment.



6dB Bandwidth -2405 MHz

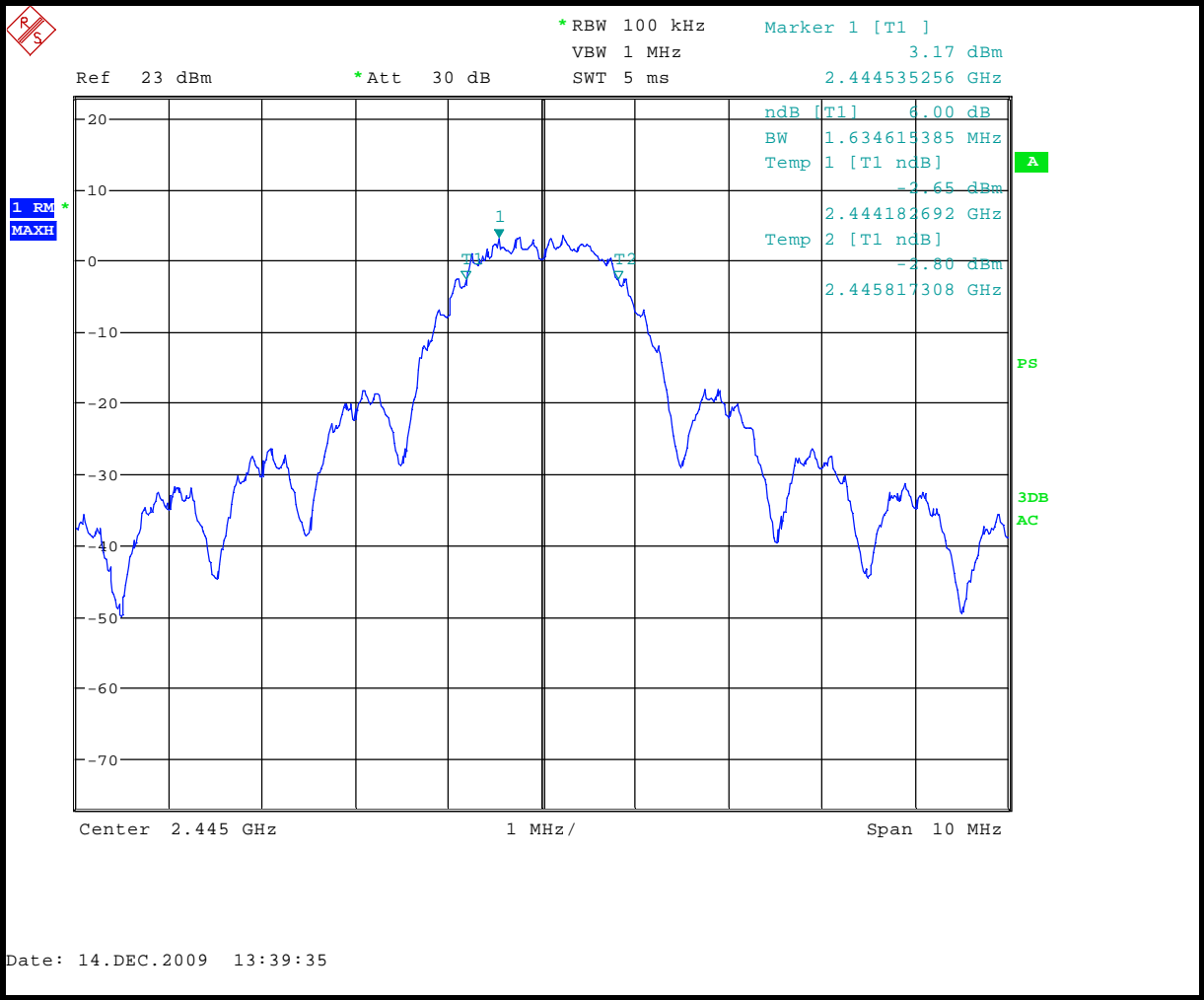

6dB Bandwidth – 2445 MHz

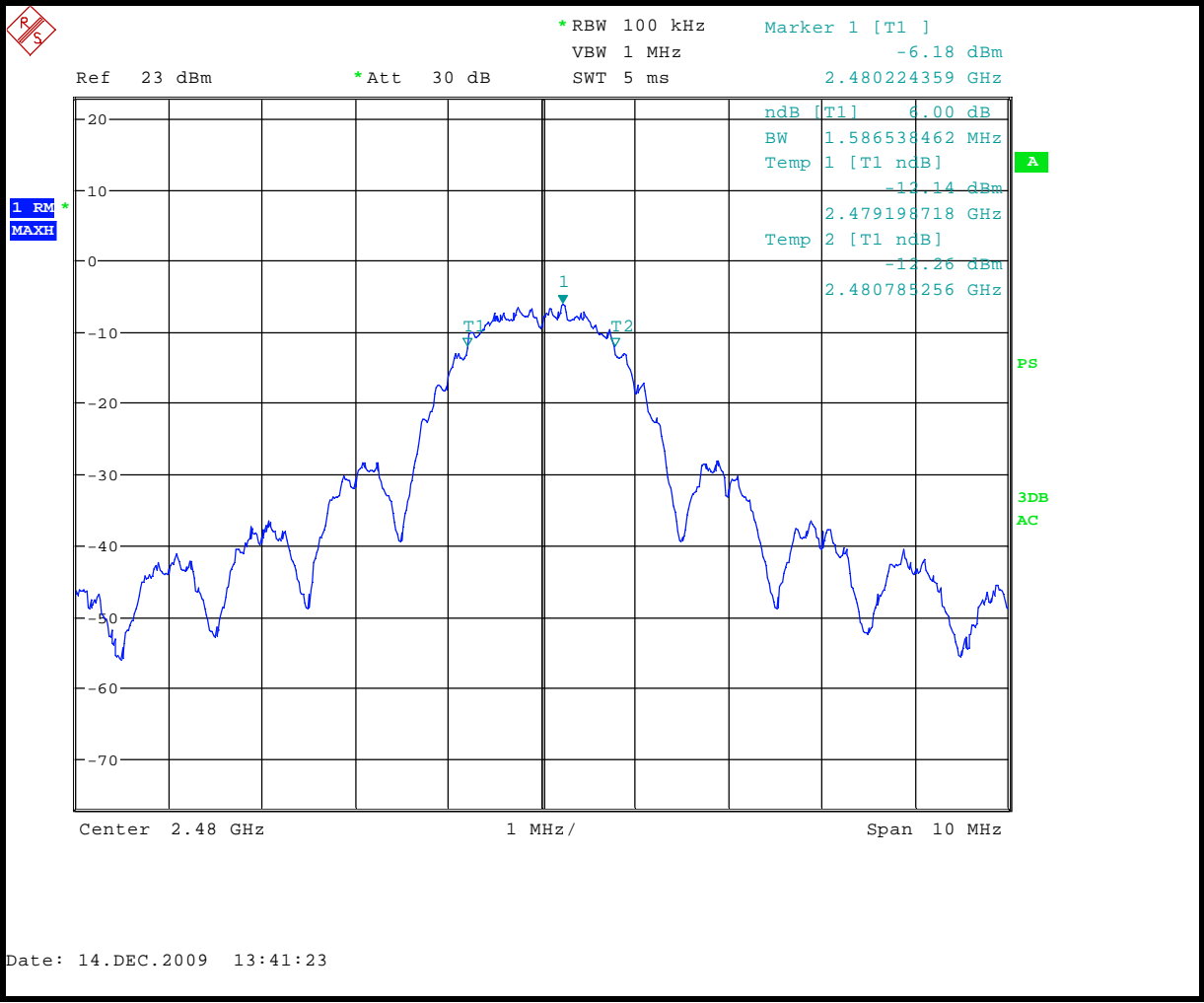

6dB Bandwidth - 2480 MHz

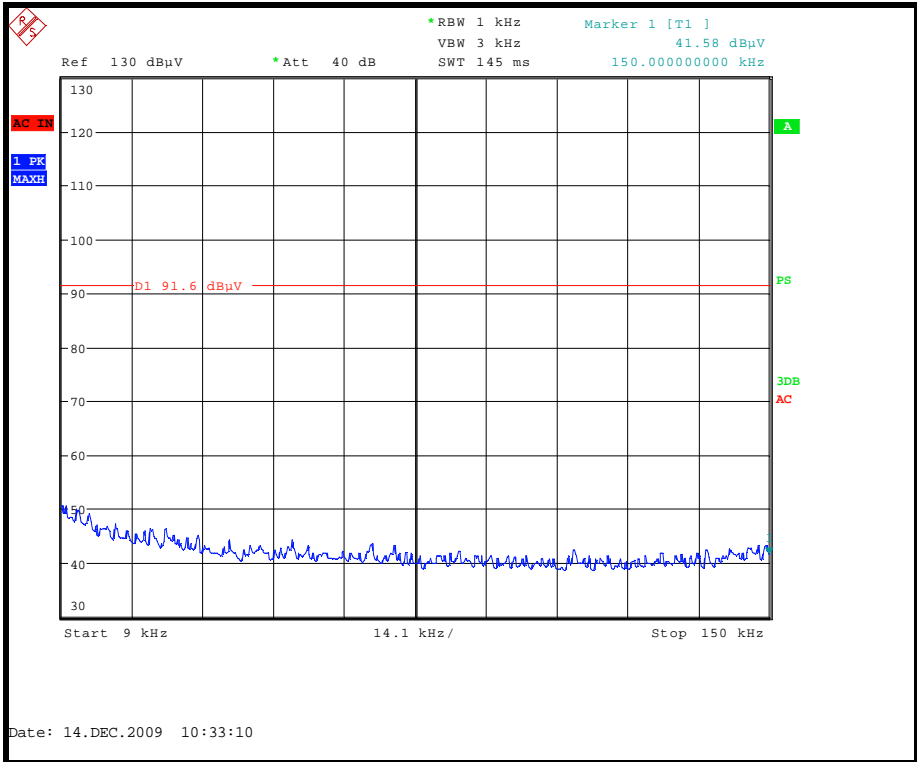

Conducted Spurious emissions 9kHz to 150 kHz – 2405 MHz

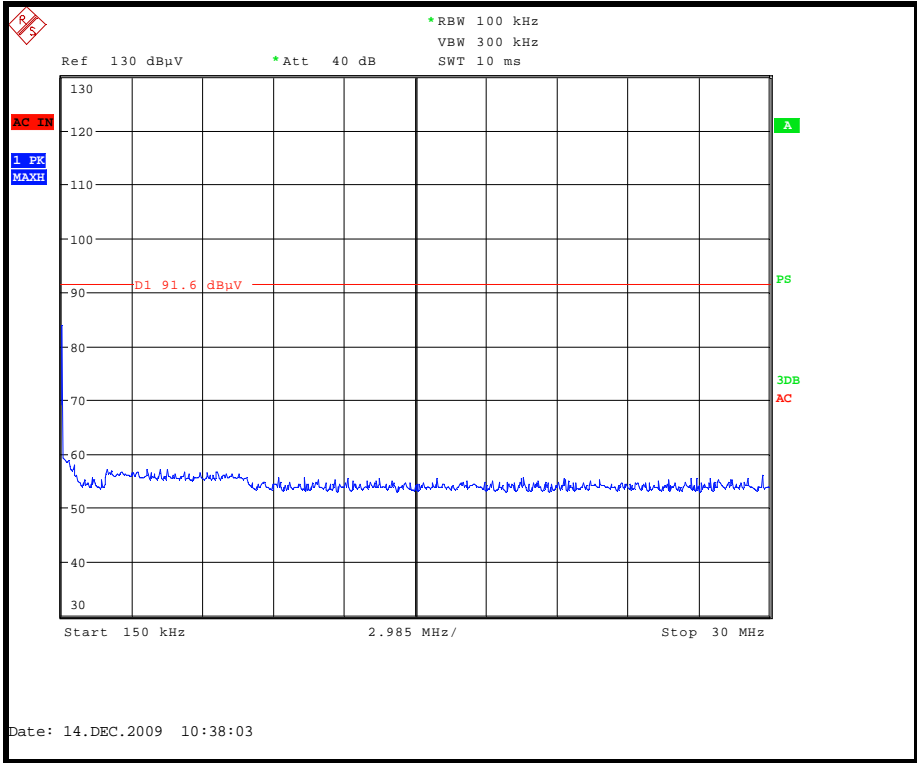

Conducted Spurious emissions 150 kHz to 30 MHz – 2405 MHz

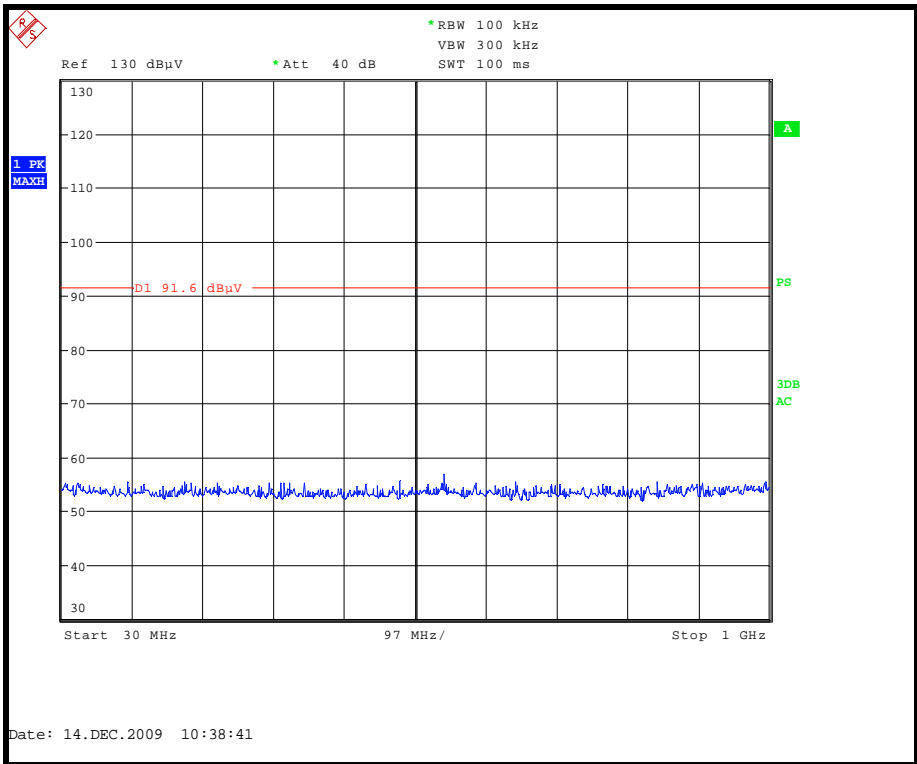

Conducted Spurious emissions 30 MHz to 1GHz - 2405 MHz

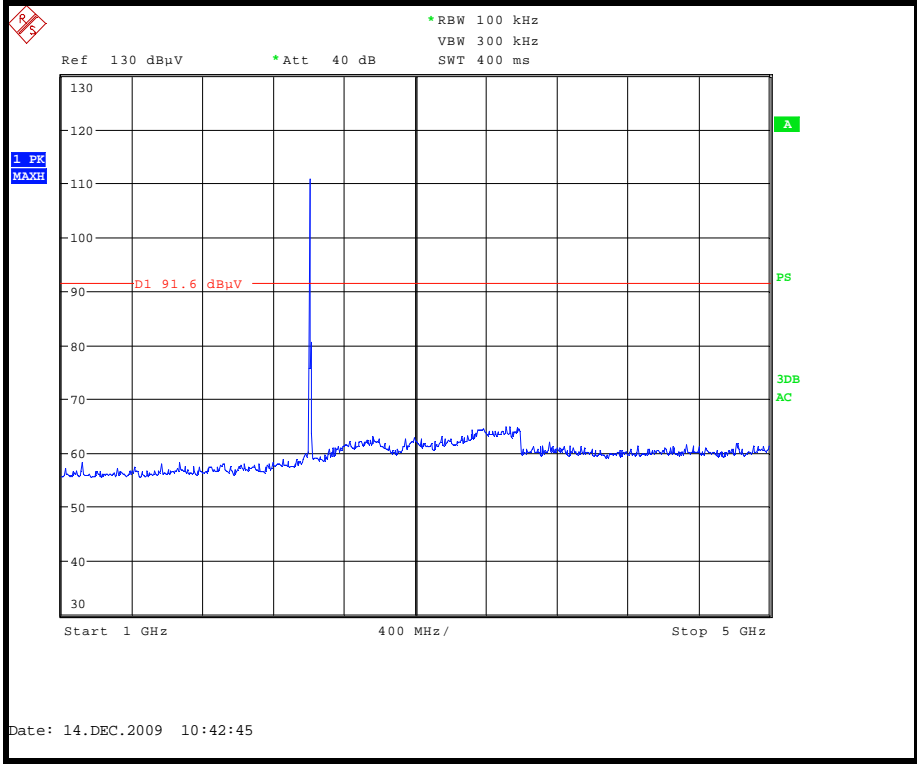

Conducted Spurious emissions 1 GHz to 5 GHz - 2405 MHz

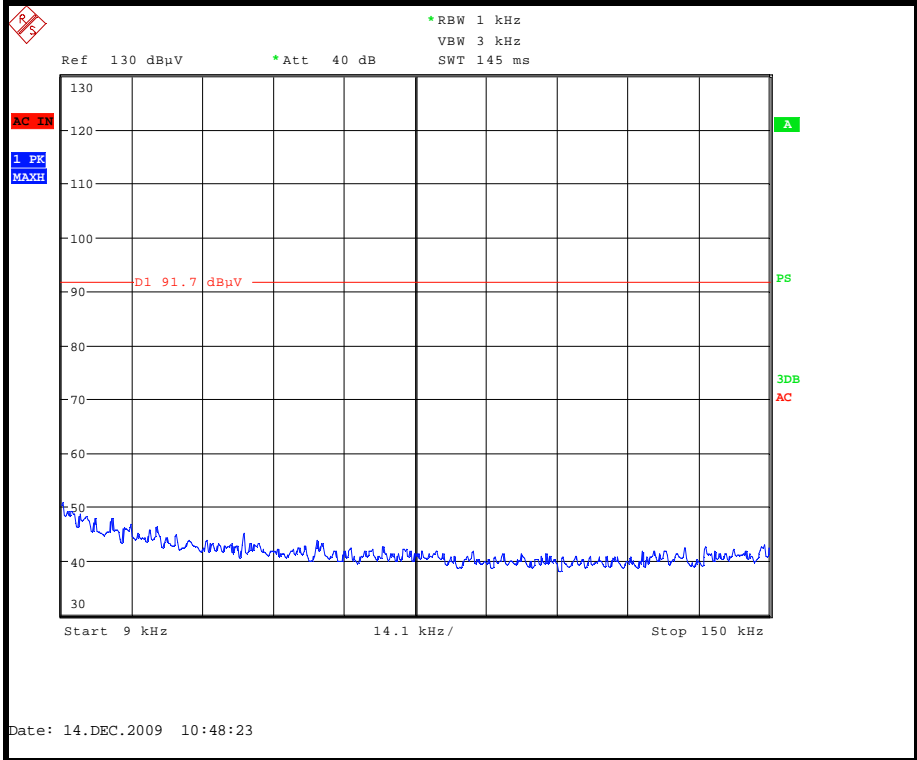

Conducted Spurious emissions 9kHz to 150 kHz – 2445 MHz

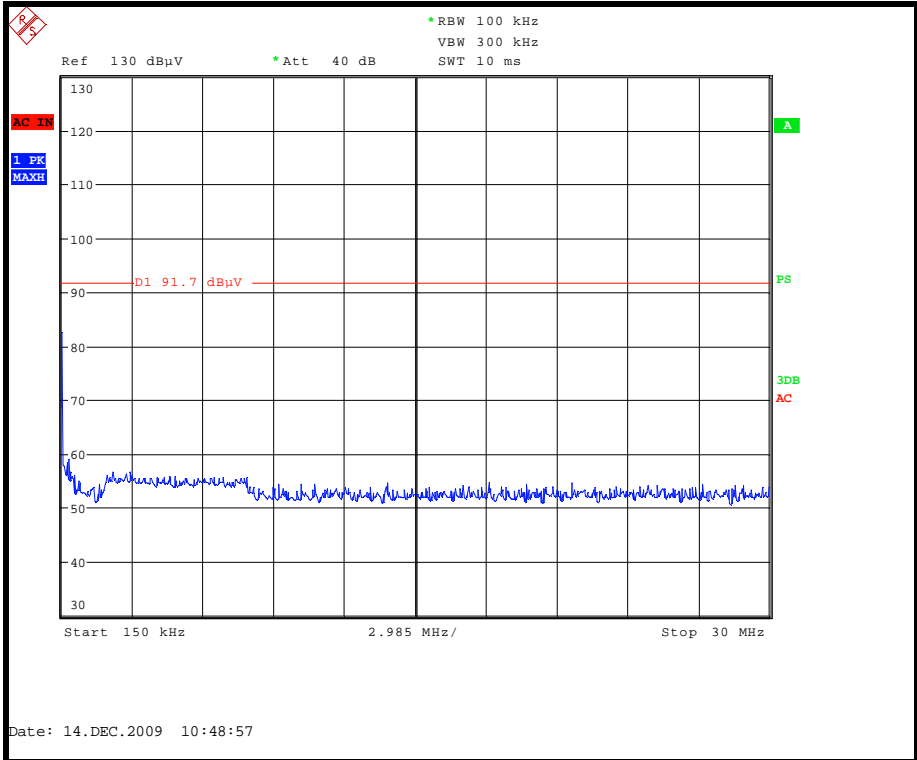

Conducted Spurious emissions 150 kHz to 30 MHz – 2445 MHz

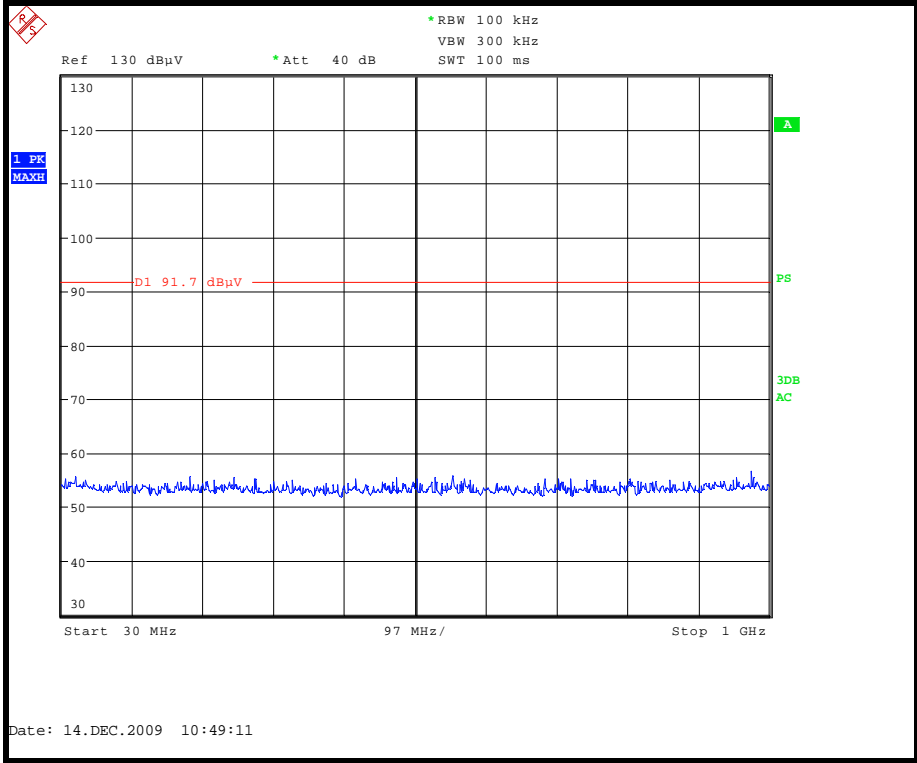

Conducted Spurious emissions 30 MHz to 1GHz - 2445 MHz

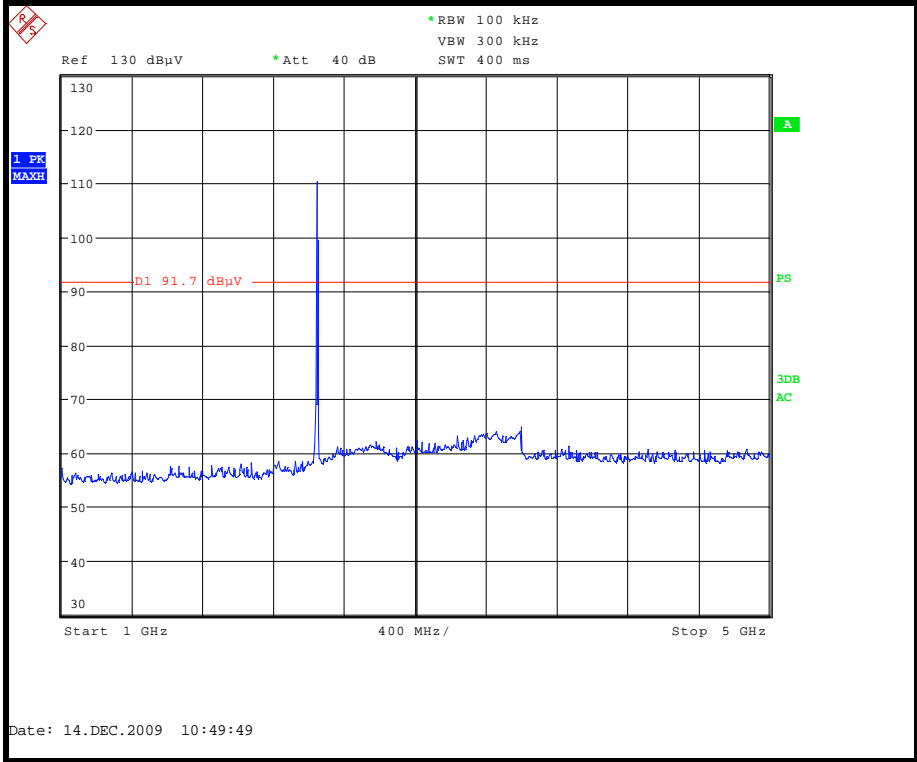

Conducted Spurious emissions 1 GHz to 5 GHz - 2445 MHz

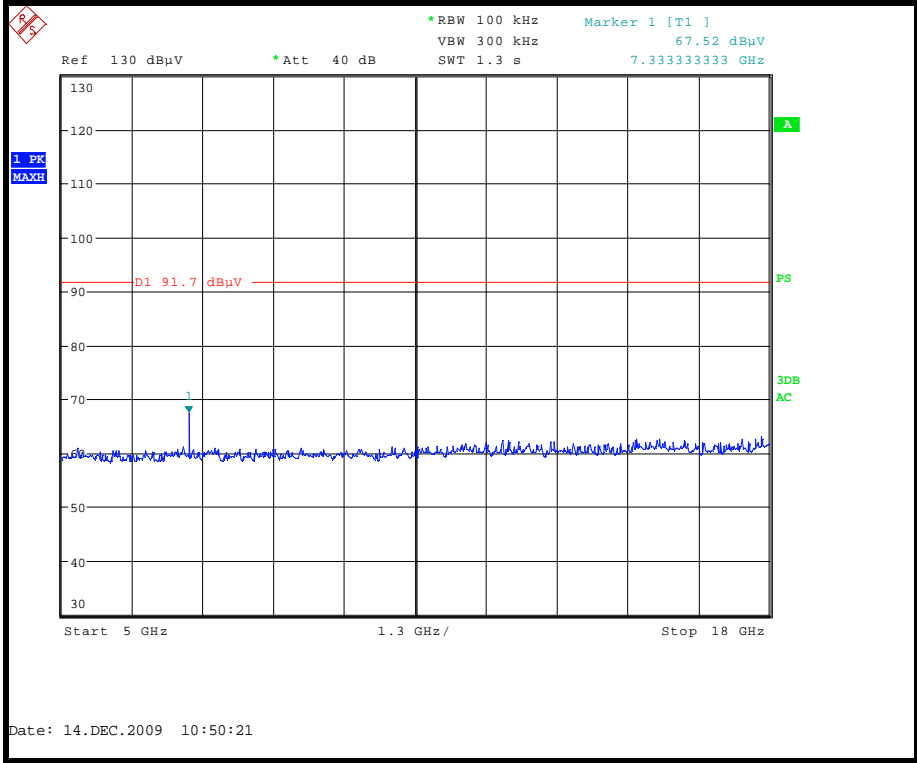

Conducted Spurious emissions 5 GHz to 18 GHz - 2445 MHz

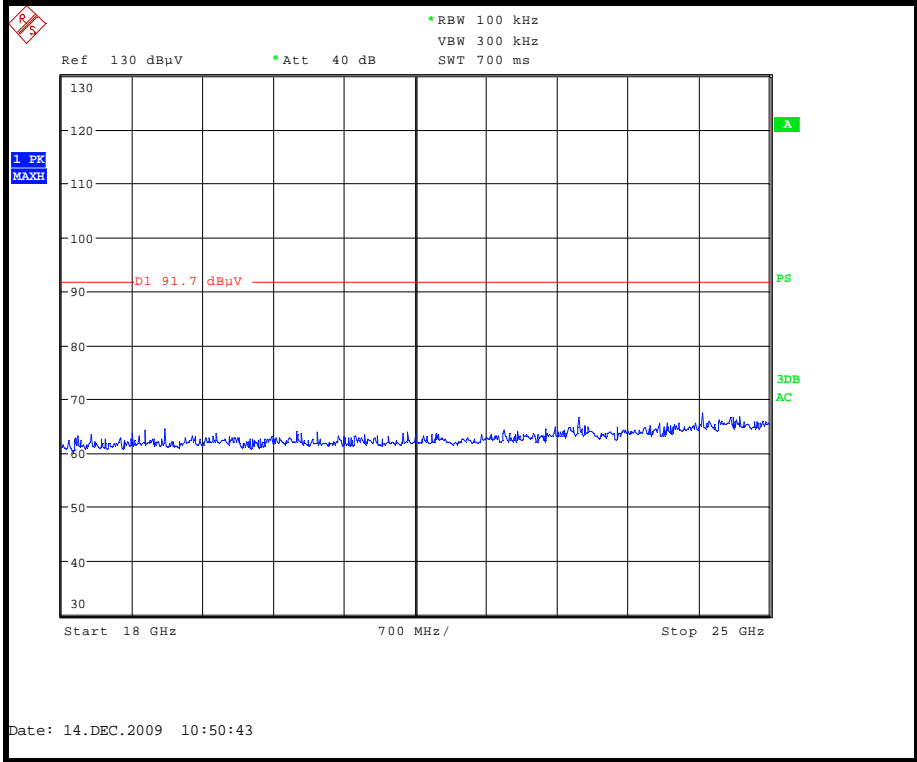

Conducted Spurious emissions 18 GHz to 25 GHz - 2445 MHz

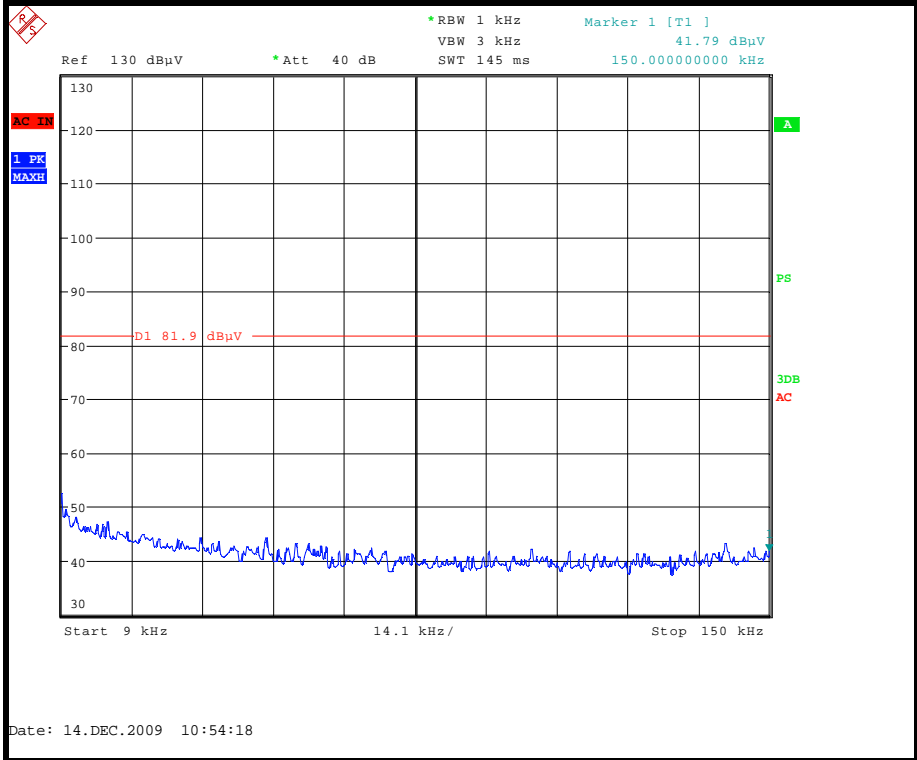

Conducted Spurious emissions 9kHz to 150 kHz – 2480 MHz

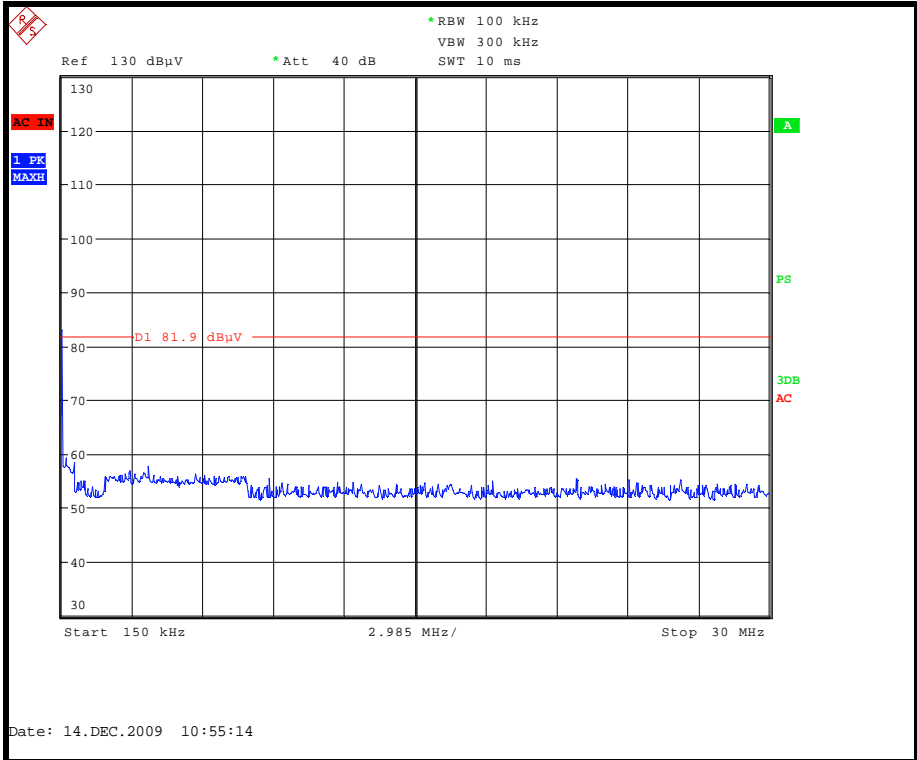

Conducted Spurious emissions 150 kHz to 30 MHz – 2480 MHz

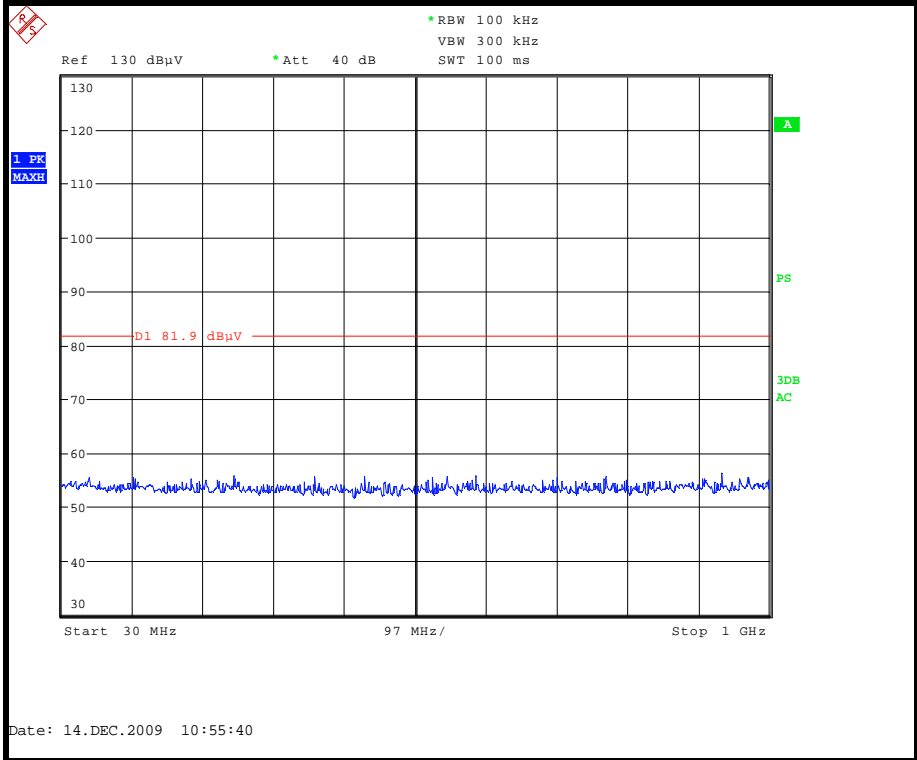

Conducted Spurious emissions 30 MHz to 1GHz - 2480 MHz

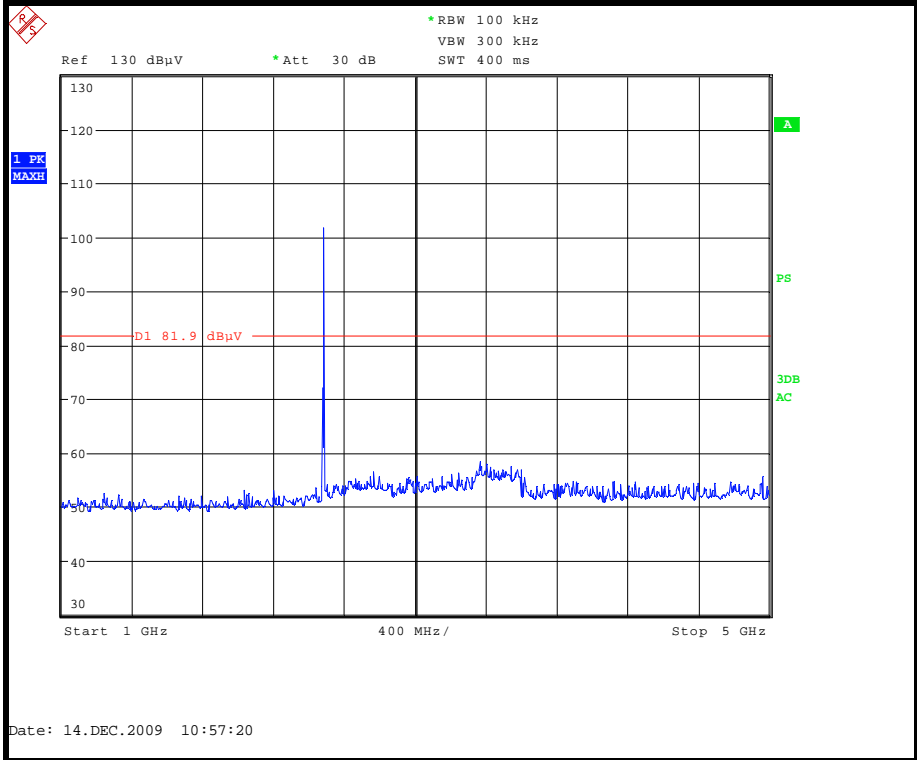

Conducted Spurious emissions 1 GHz to 5 GHz - 2480 MHz

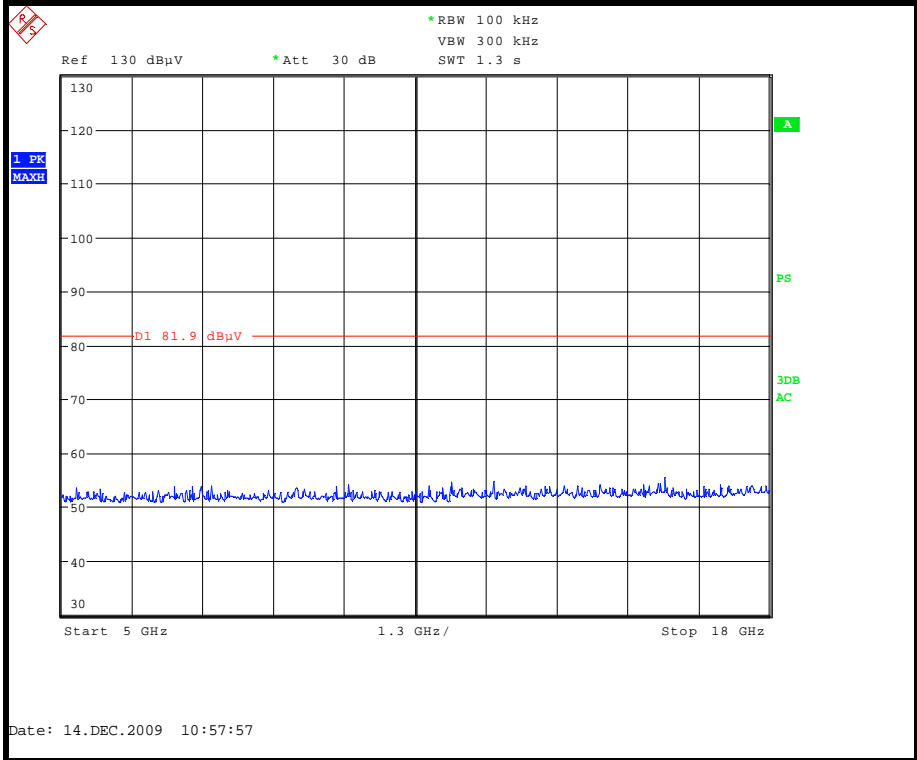

Conducted Spurious emissions 5 GHz to 18 GHz - 2480 MHz

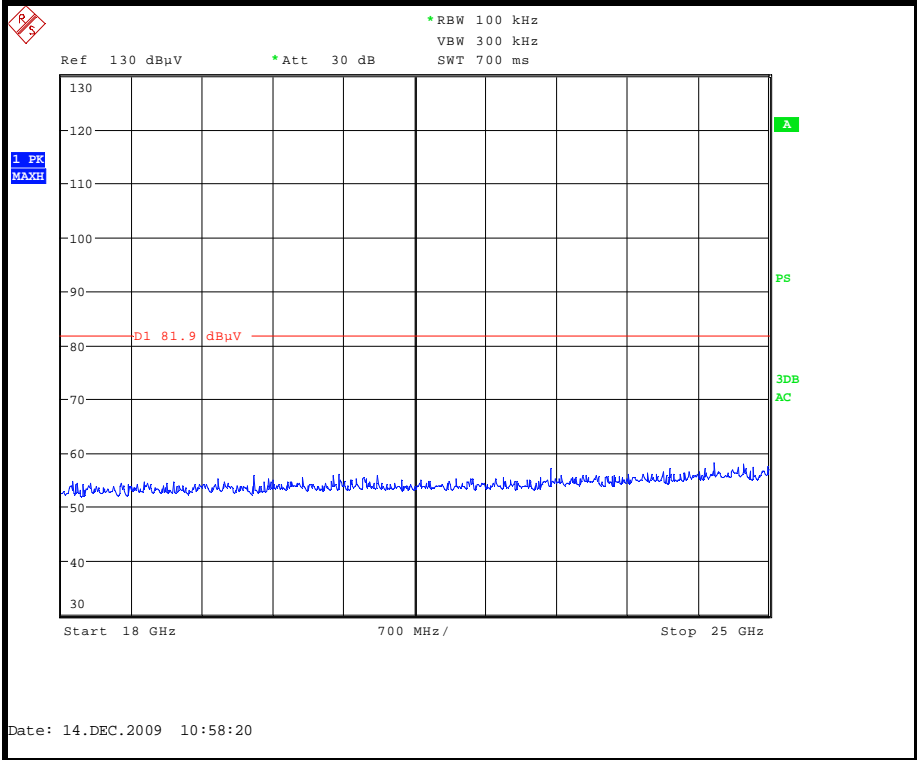

Conducted Spurious emissions 18 GHz to 25 GHz - 2480 MHz

Conducted Band Edge Compliance

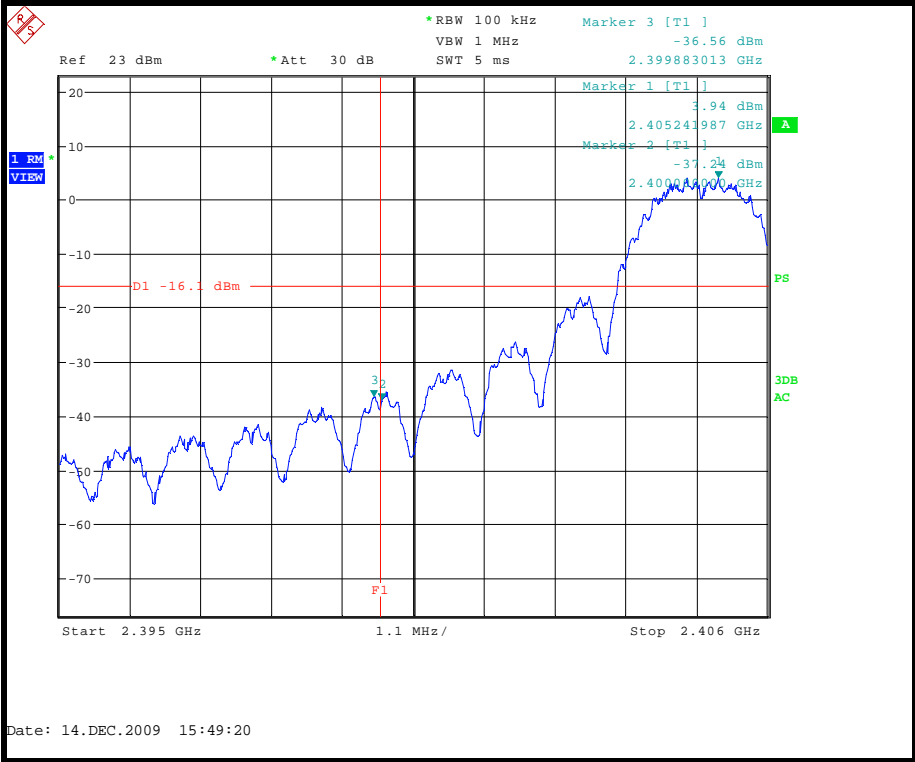

Lower Band Edge

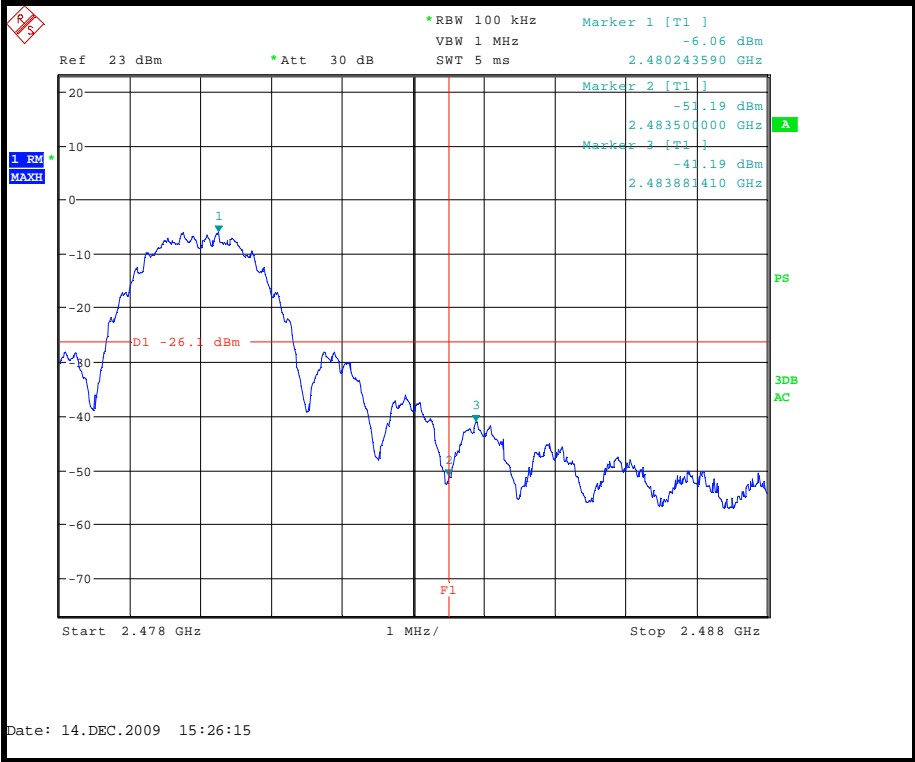

Upper Band Edge

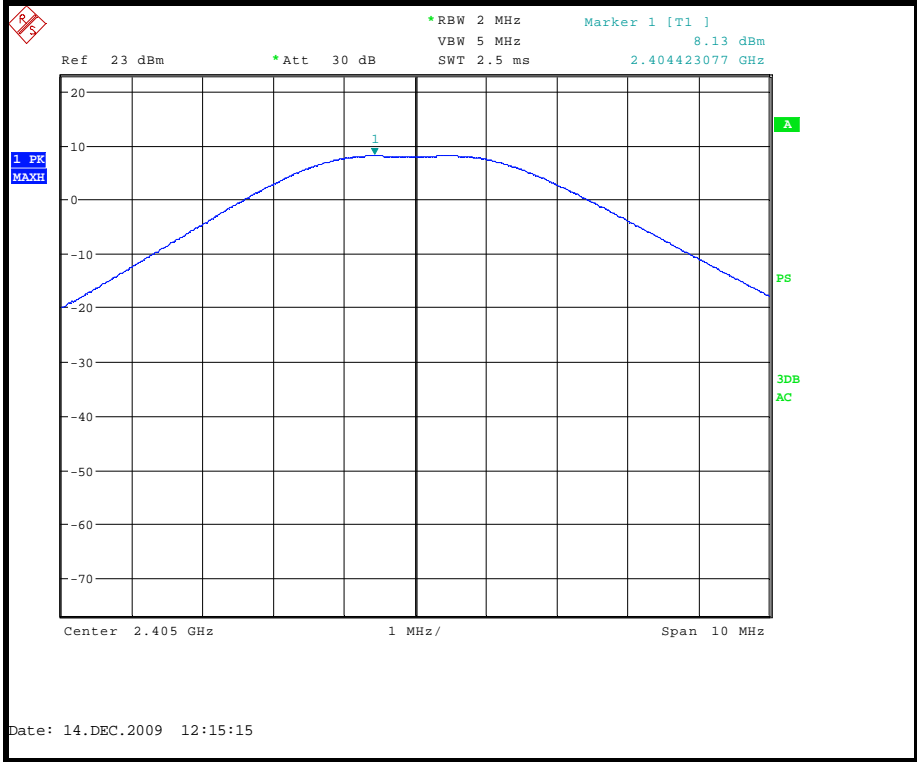

Conducted carrier power - 2405 MHz



Conducted carrier power - 2445 MHz



Conducted carrier power - 2480 MHz

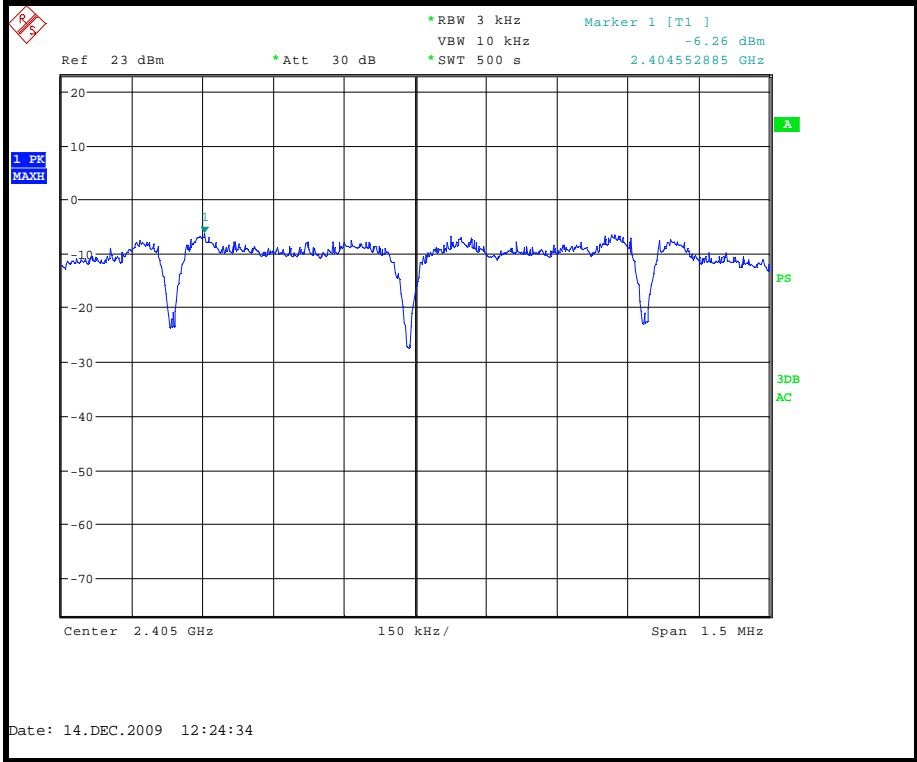

Conducted power spectral density – 2405 MHz

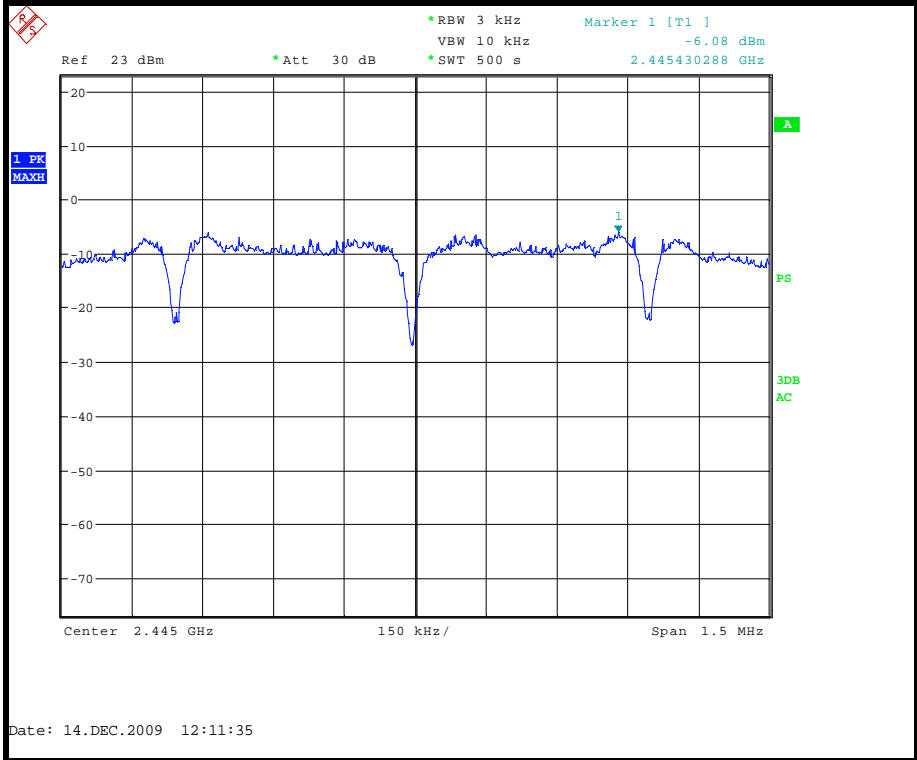

Conducted power spectral density - 2445 MHz

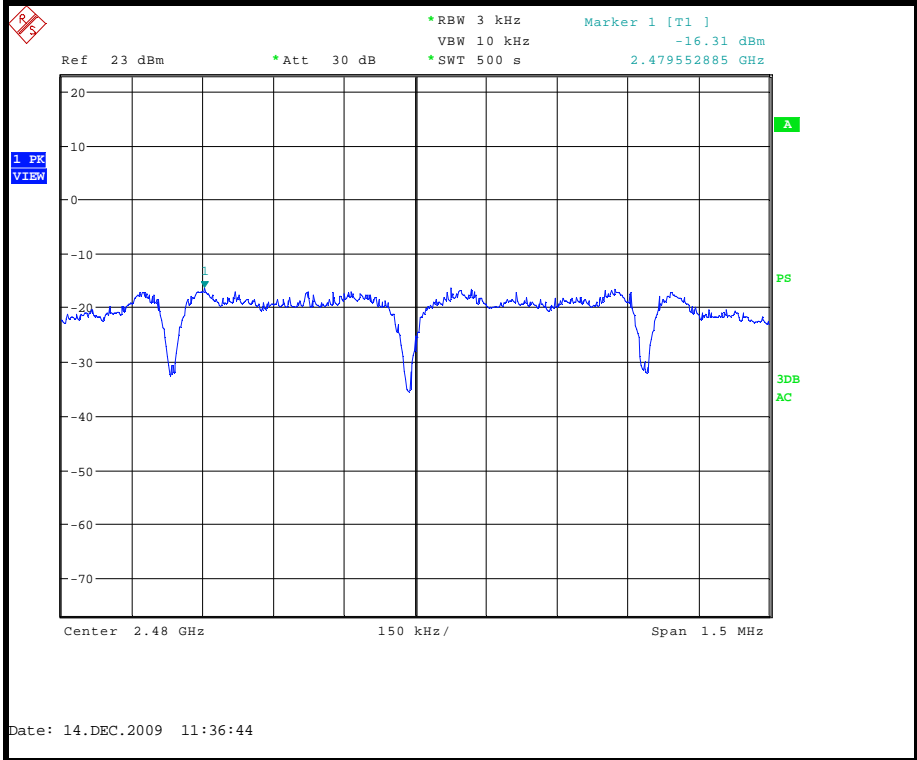

Conducted power spectral density - 2480 MHz

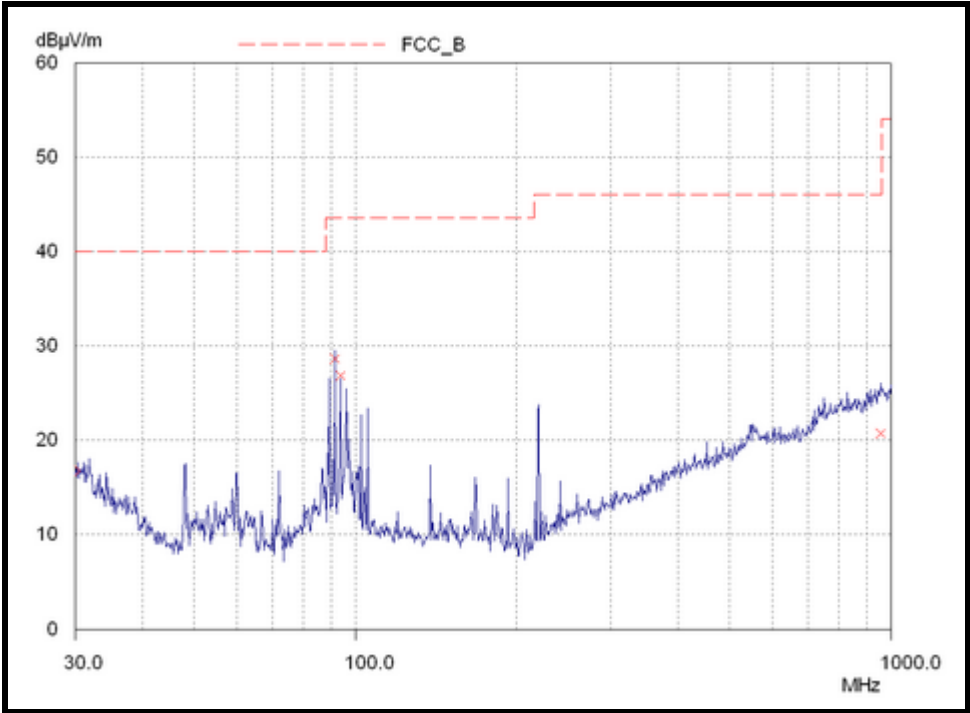

Radiated Spurious emissions 30 MHz to 1 GHz – 2405 MHz

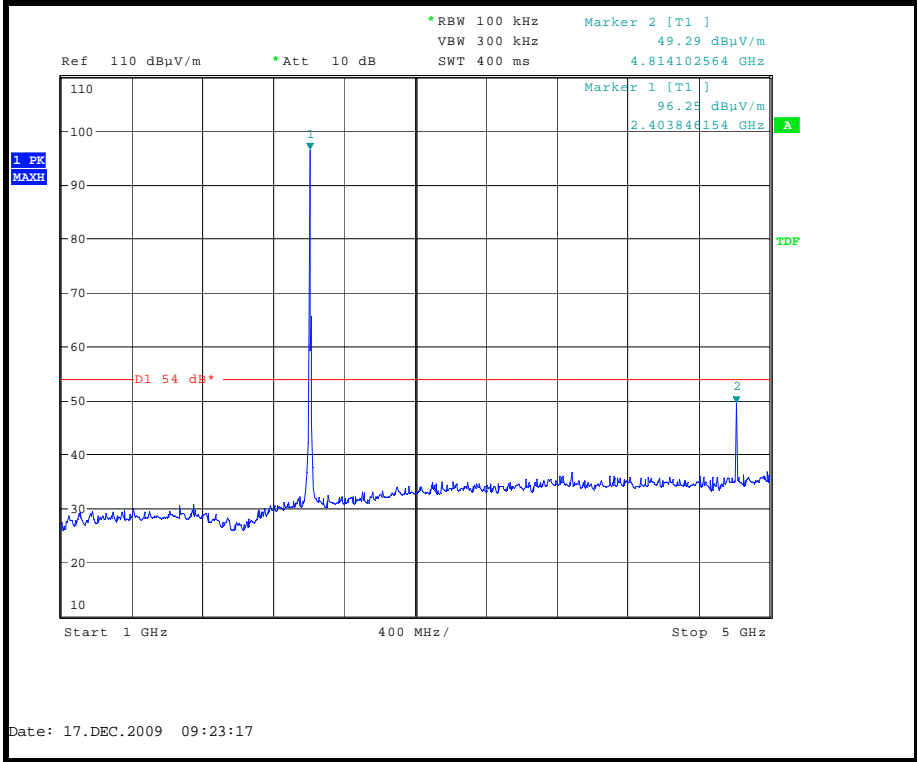

Radiated Spurious emissions 1 GHz to 5 GHz – 2405 MHz

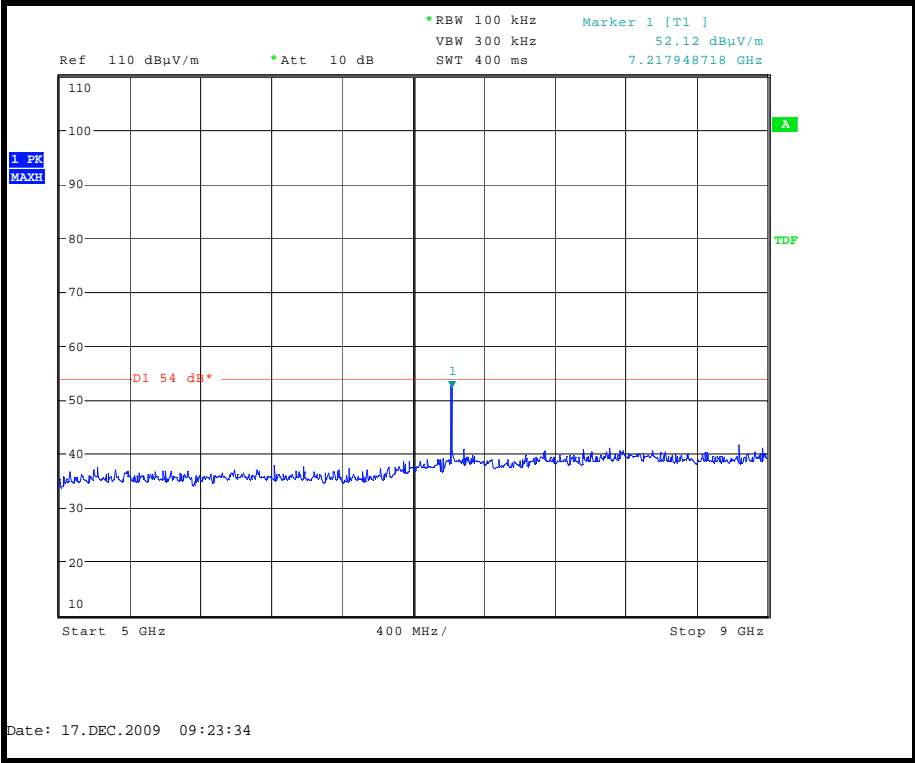

Radiated Spurious emissions 5 GHz to 9 GHz – 2405 MHz

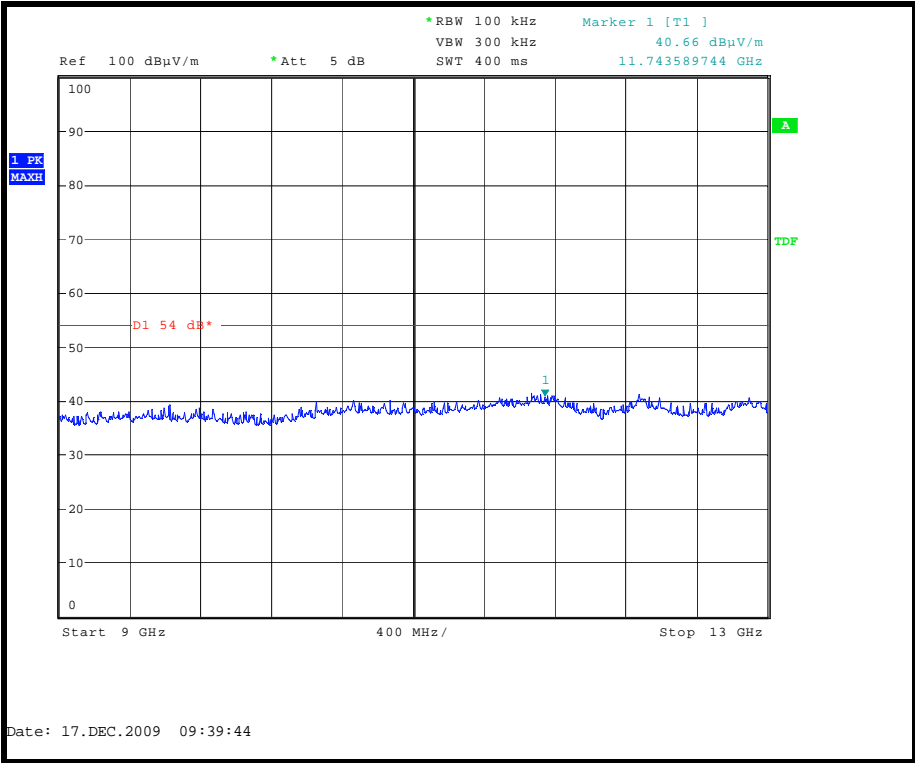

Radiated Spurious emissions 9 GHz to 13 GHz – 2405 MHz

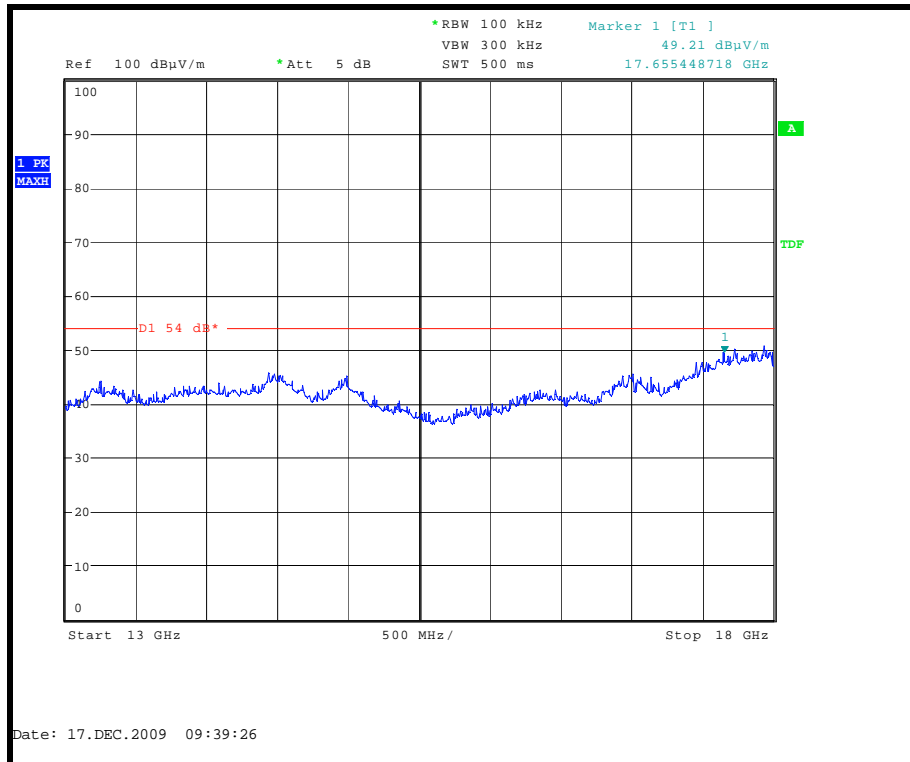

Radiated Spurious emissions 13 GHz to 18GHz – 2405 MHz

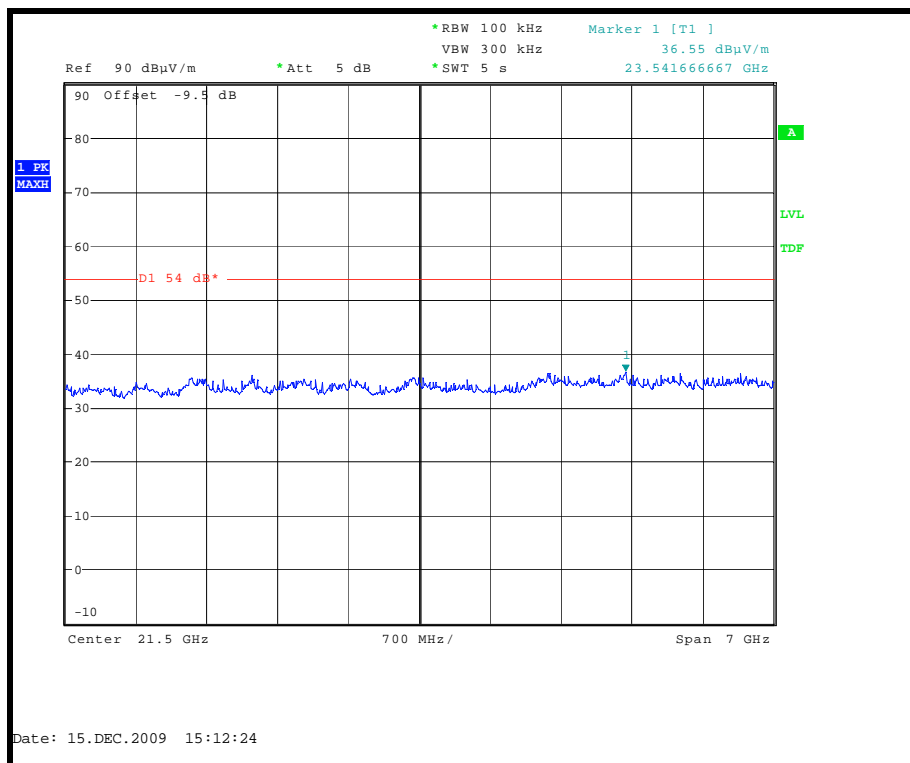

Radiated Spurious emissions 18 GHz to 25 GHz – 2405 MHz

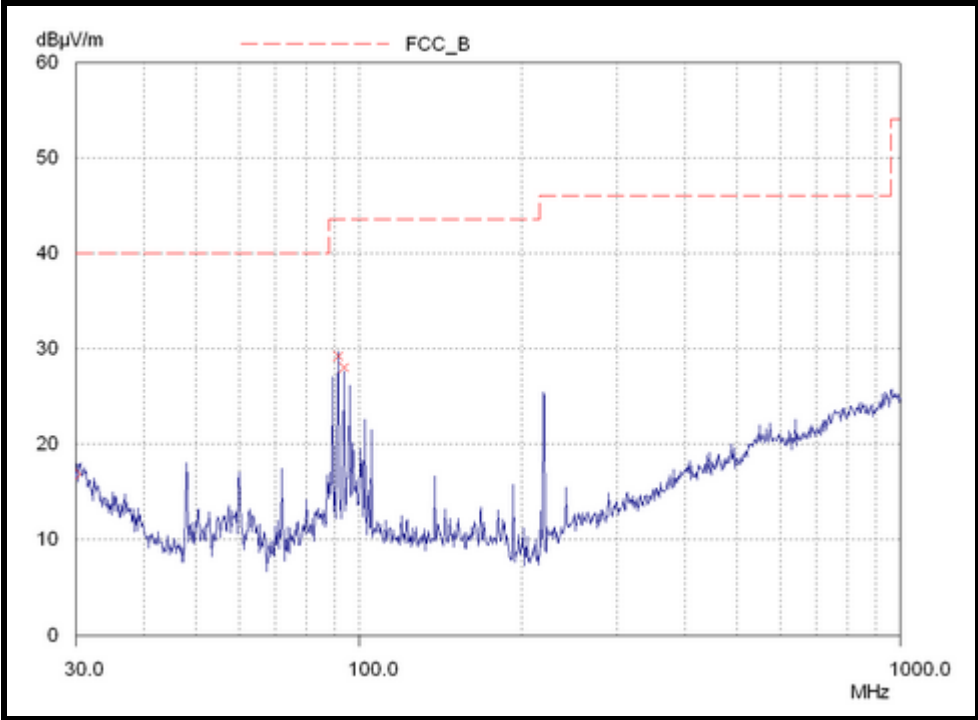

Radiated Spurious emissions 30 MHz to 1 GHz - 2445 MHz

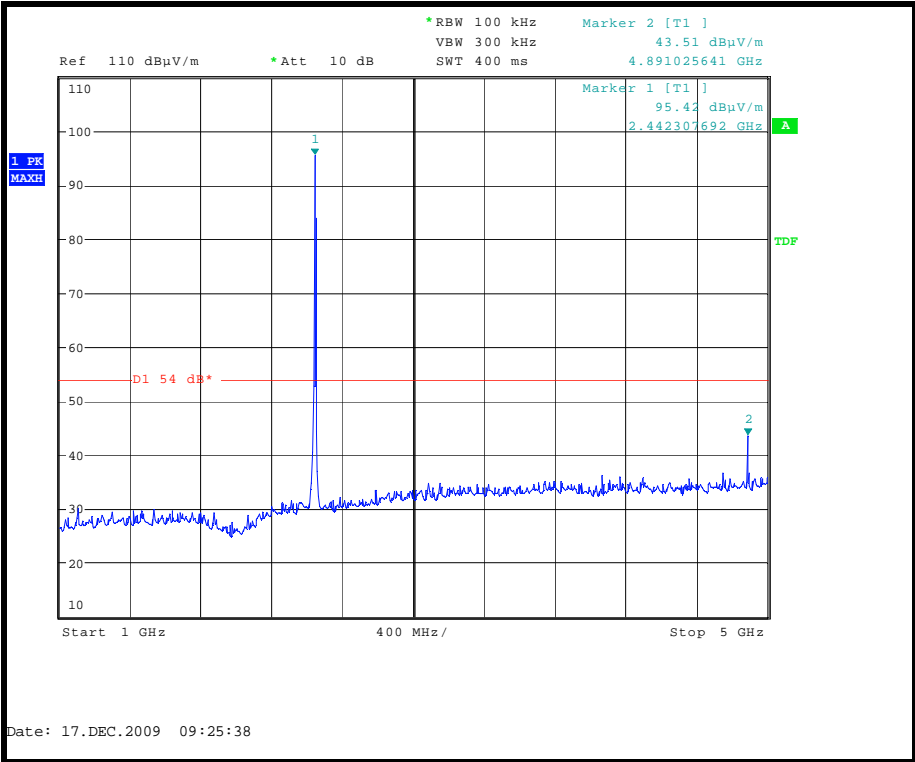

Radiated Spurious emissions 1 GHz to 5 GHz - 2445 MHz

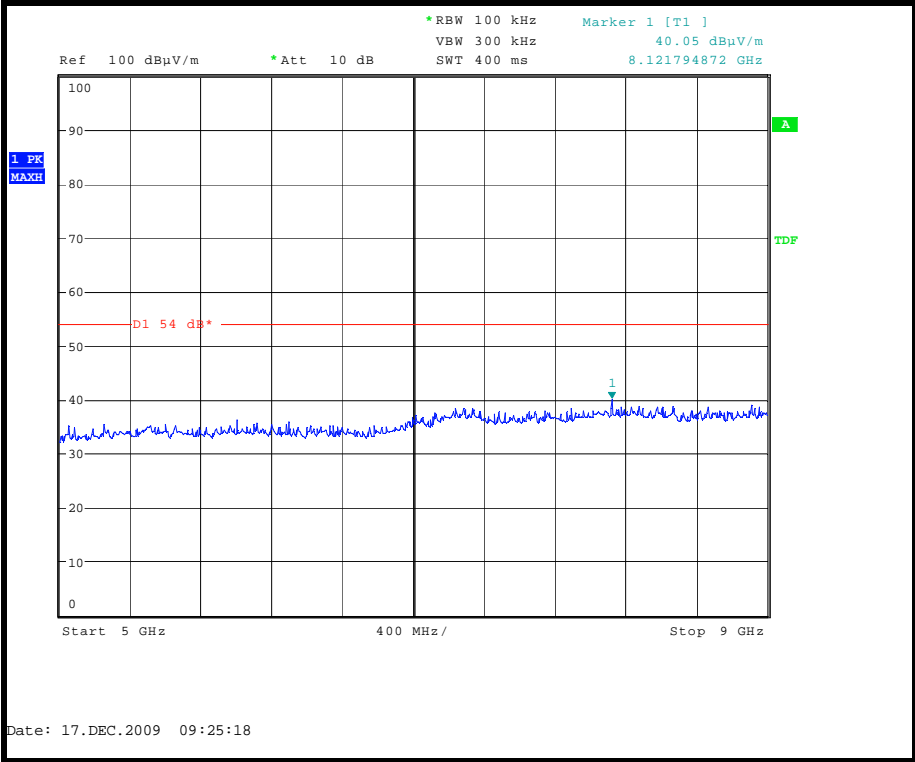

Radiated Spurious emissions 5 GHz to 9 GHz - 2445 MHz

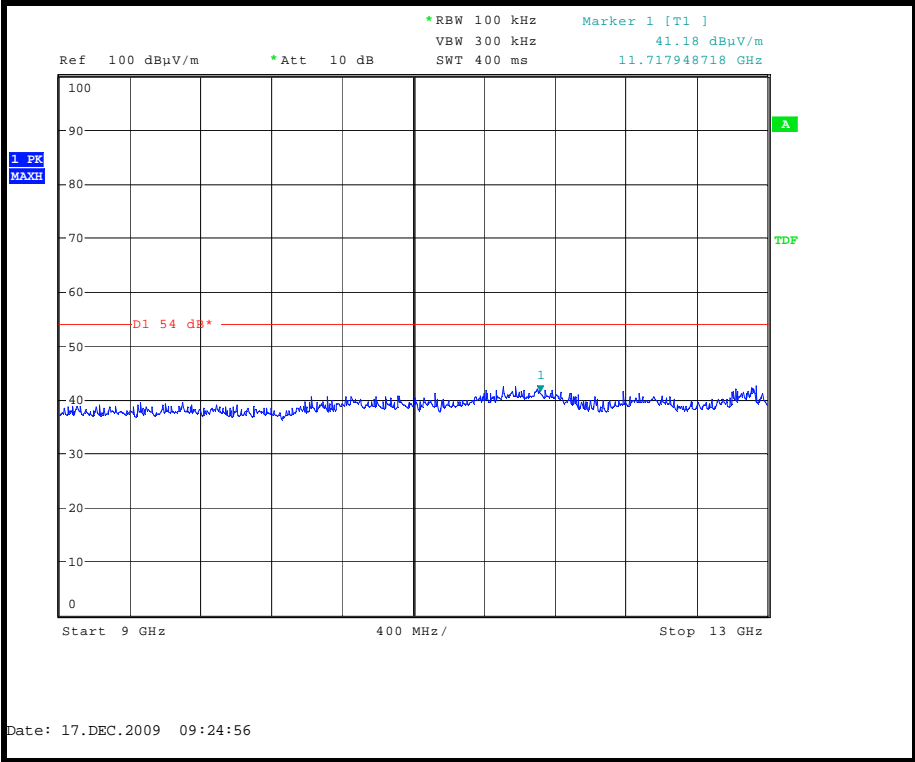

Radiated Spurious emissions 9 GHz to 13 GHz - 2445 MHz



Radiated Spurious emissions 13 GHz to 18GHz - 2445 MHz

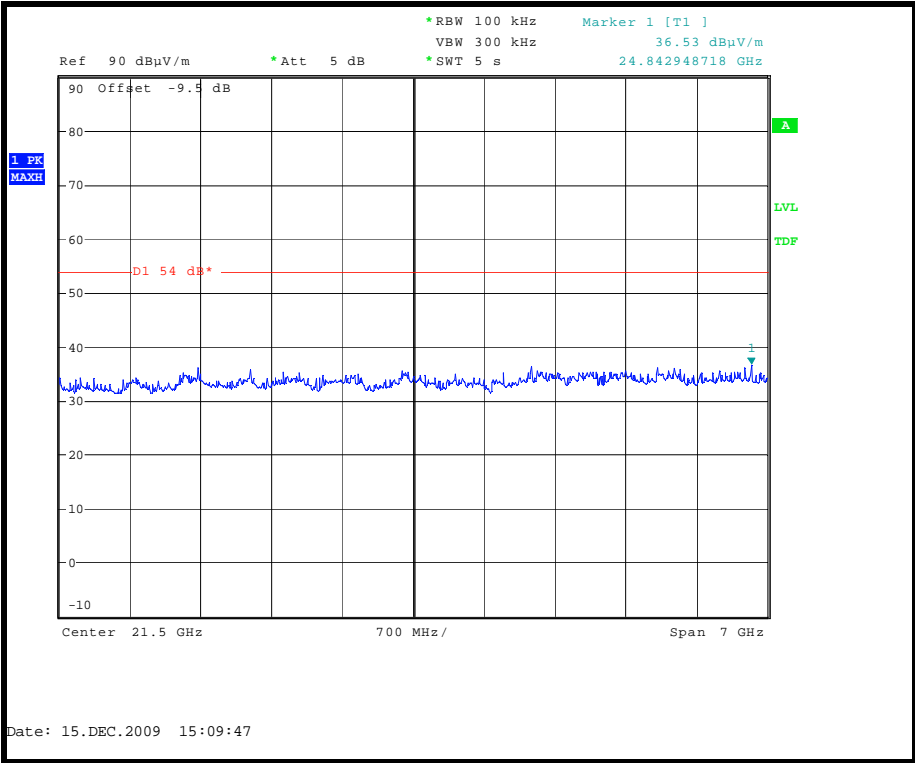

Radiated Spurious emissions 18 GHz to 25 GHz - 2445 MHz

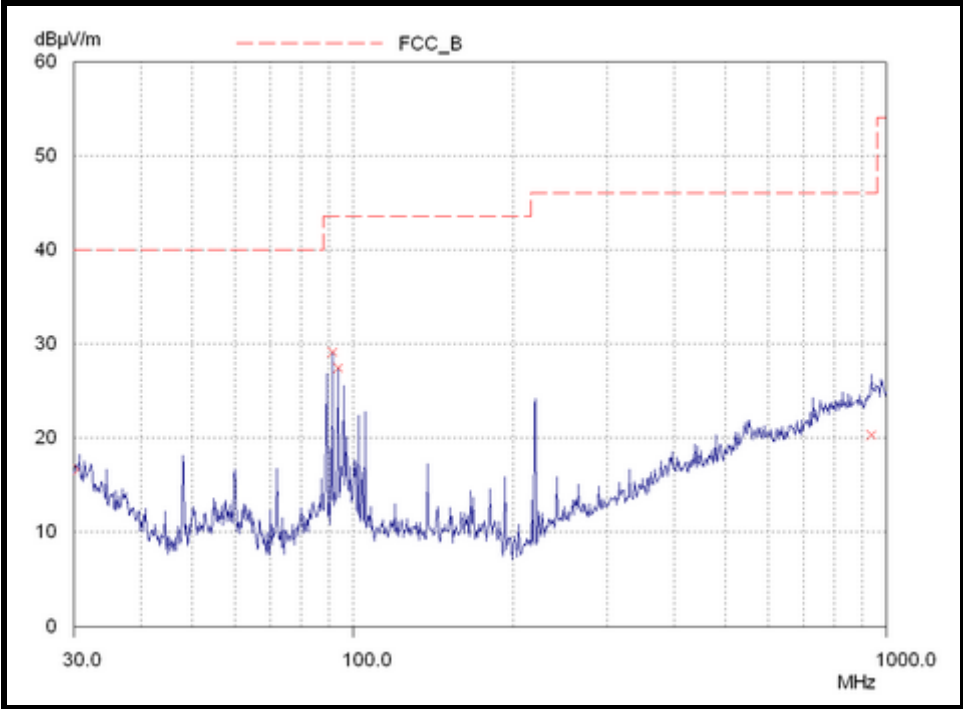

Radiated Spurious emissions 30 MHz to 1 GHz - 2480 MHz

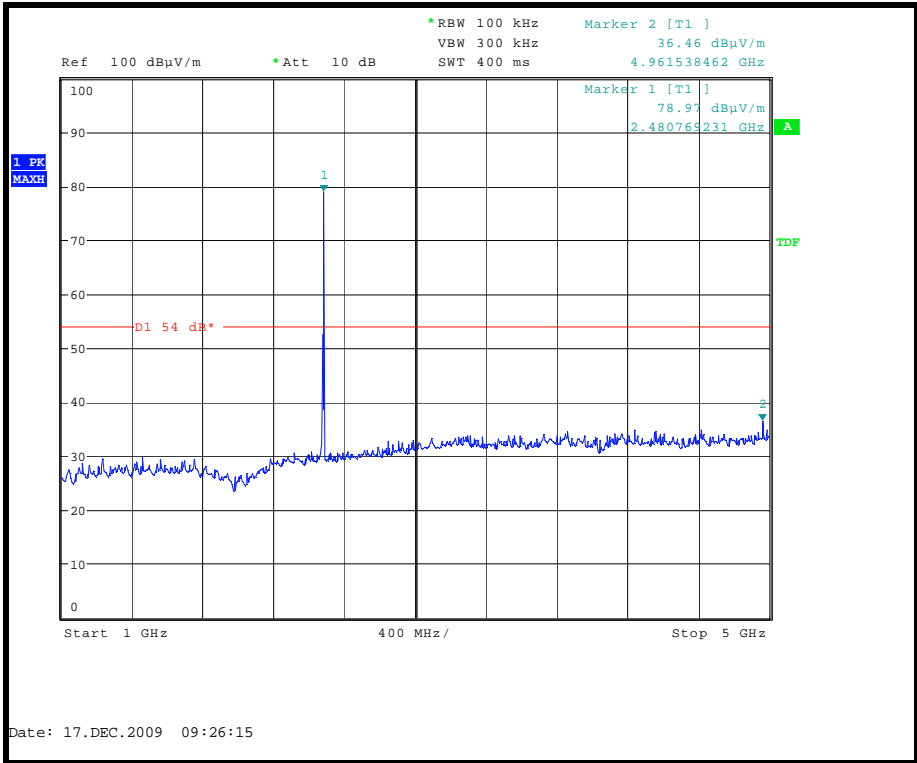

Radiated Spurious emissions 1 GHz to 5 GHz - 2480 MHz

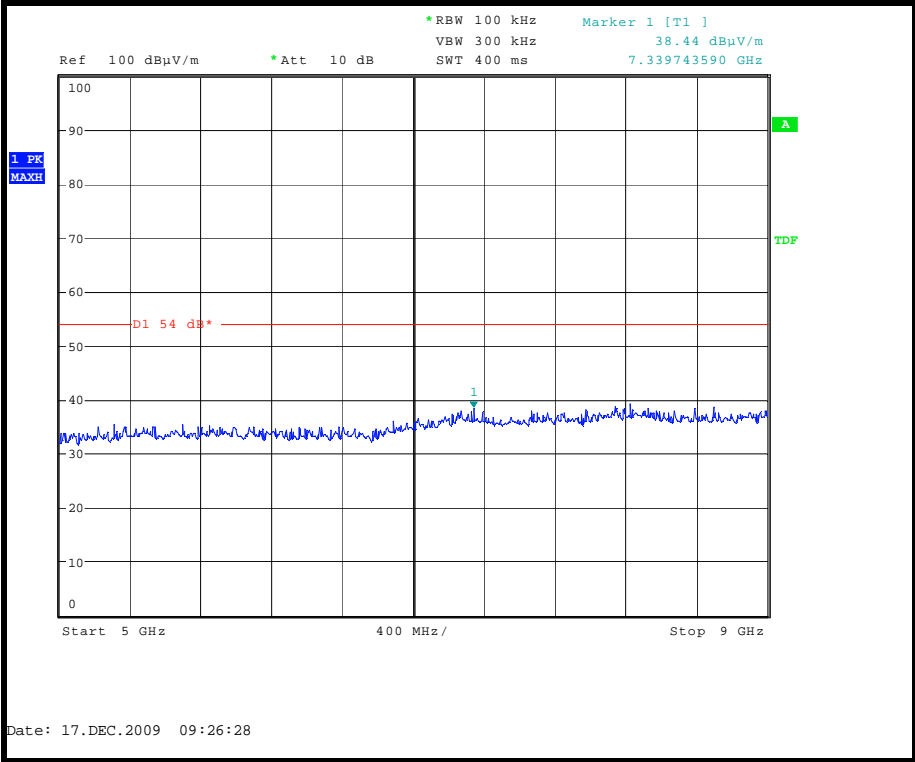

Radiated Spurious emissions 5 GHz to 9 GHz - 2480 MHz

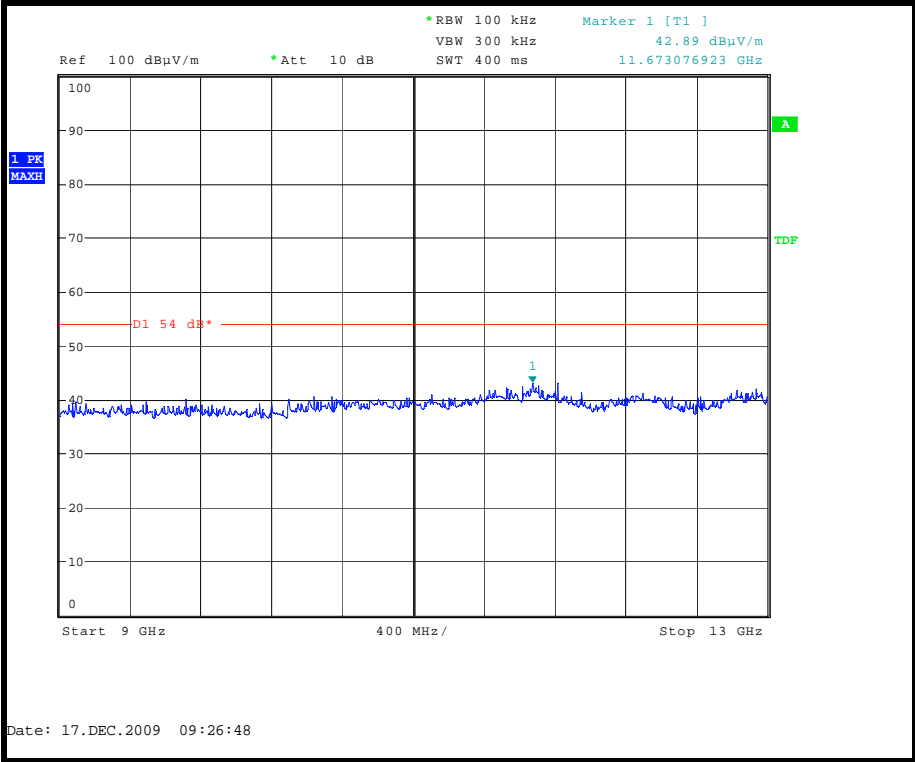

Radiated Spurious emissions 9 GHz to 13 GHz - 2480 MHz



Radiated Spurious emissions 13 GHz to 18GHz - 2480 MHz

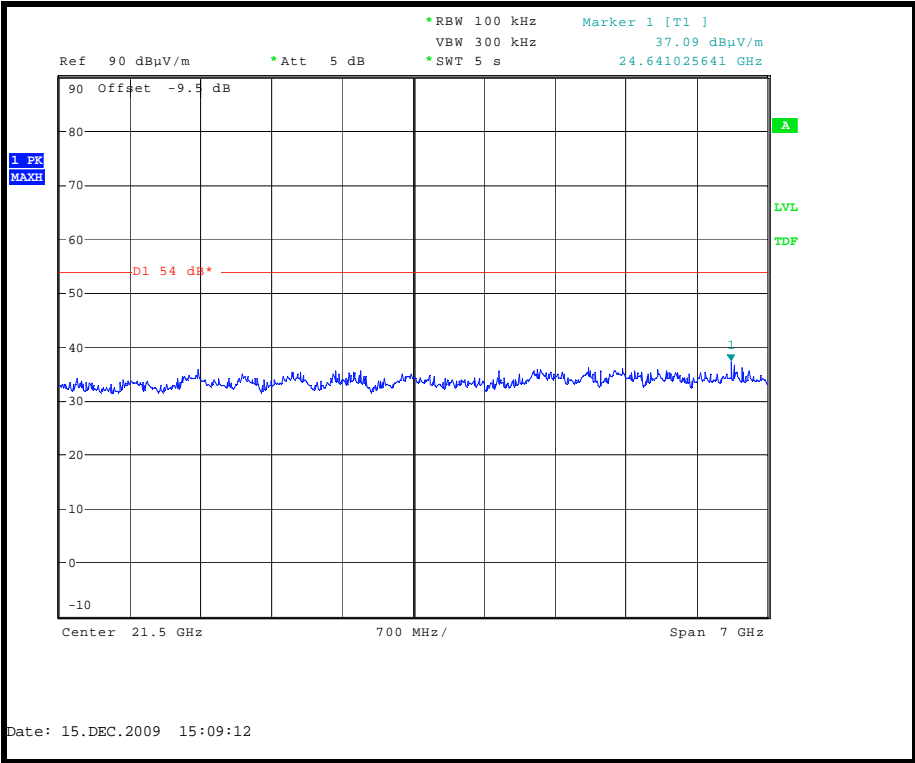

Radiated Spurious emissions 18 GHz to 25 GHz - 2480 MHz

Radiated Band Edge Compliance

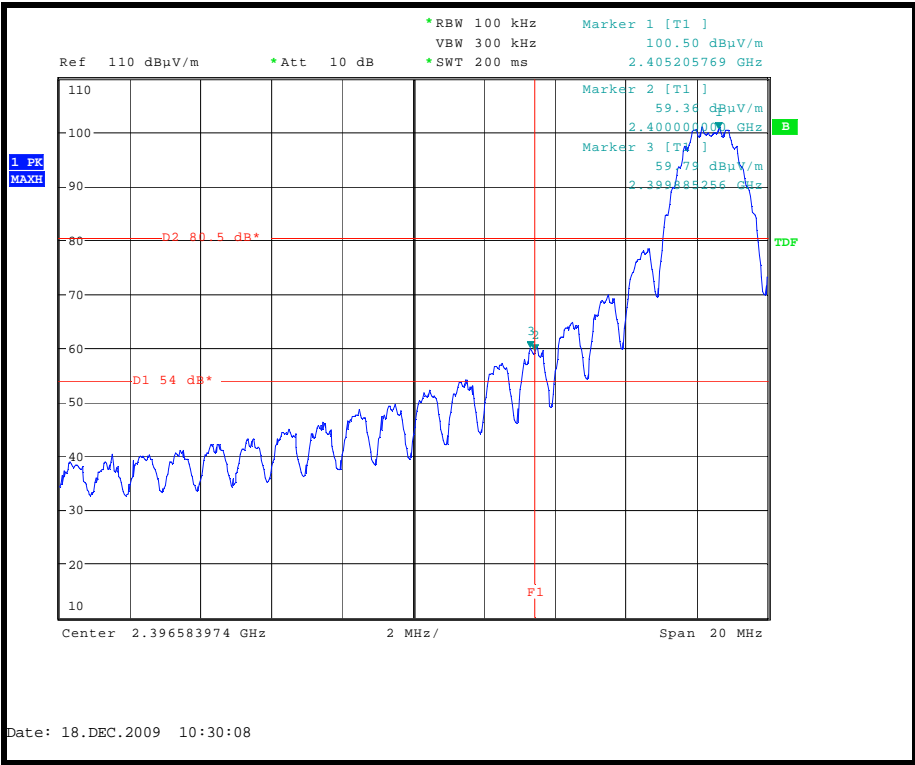

Lower Band Edge

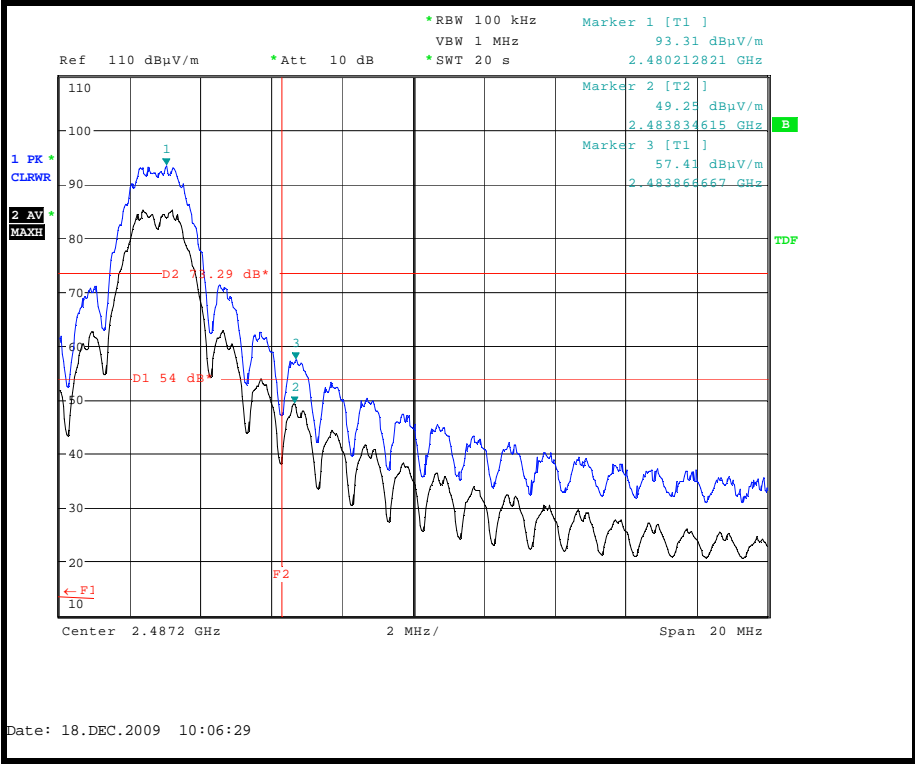

Upper Band Edge

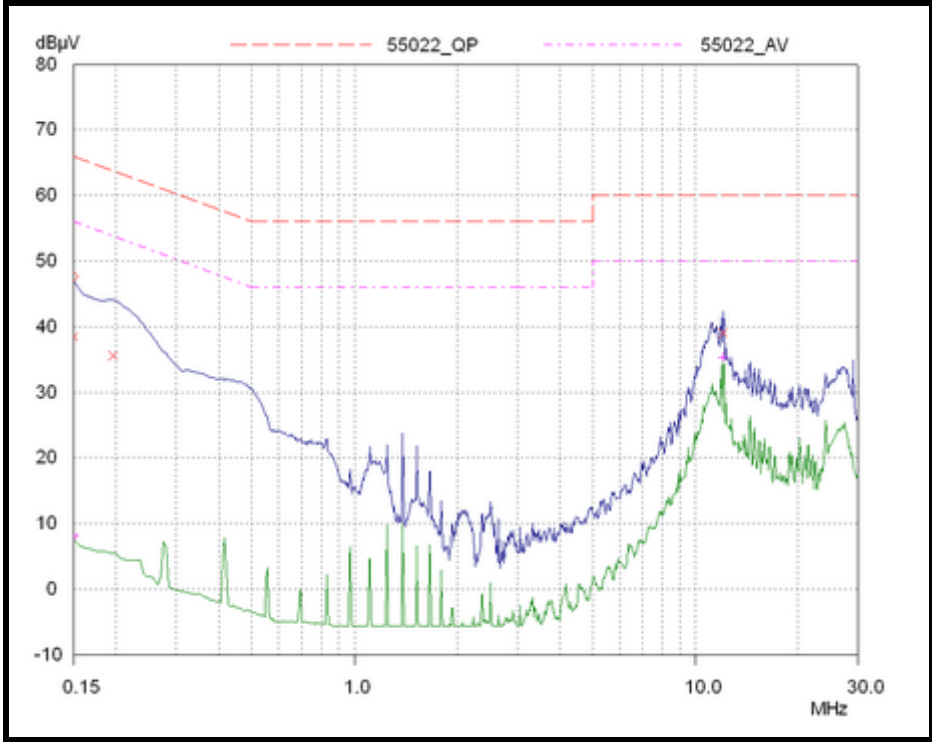

PLCE- EUT transmitting live Line

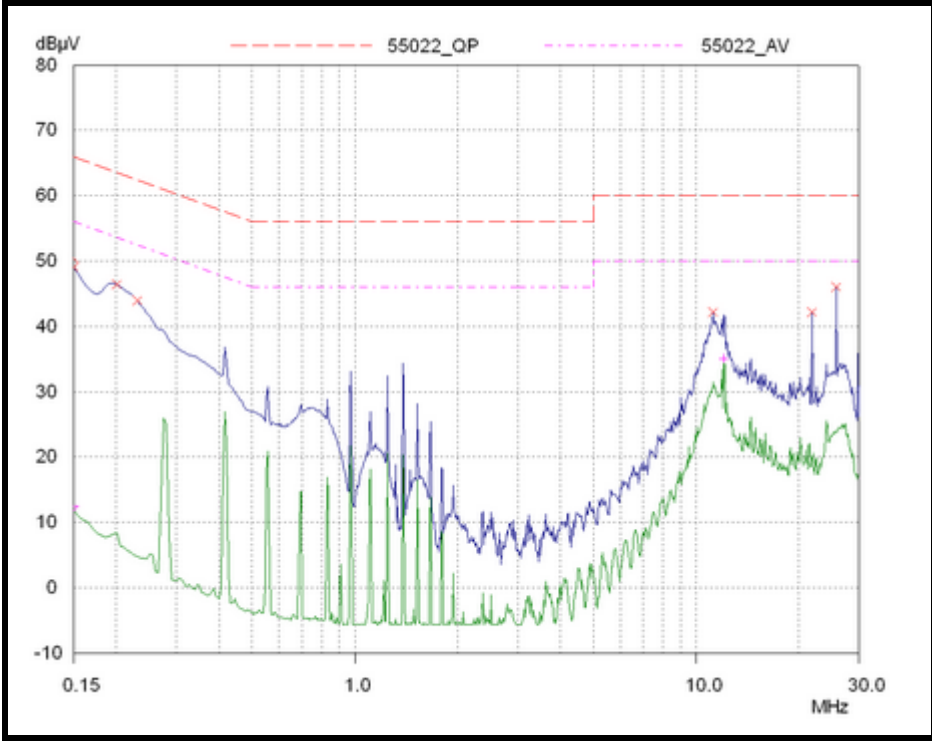

PLCE - EUT transmitting Neutral Line

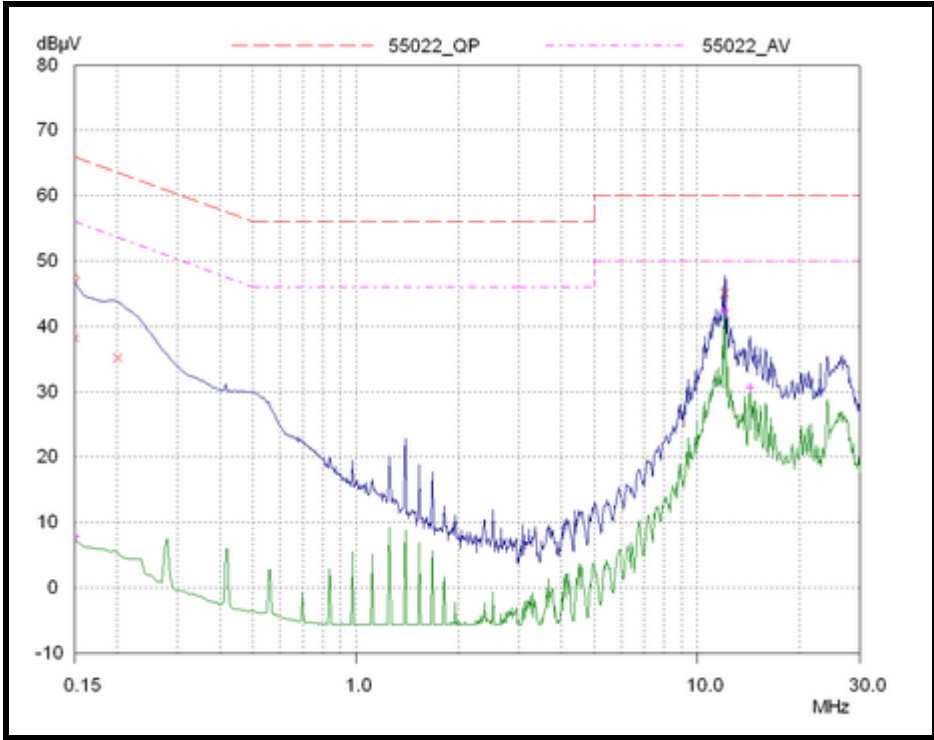

PLCE - EUT Receiving live Line

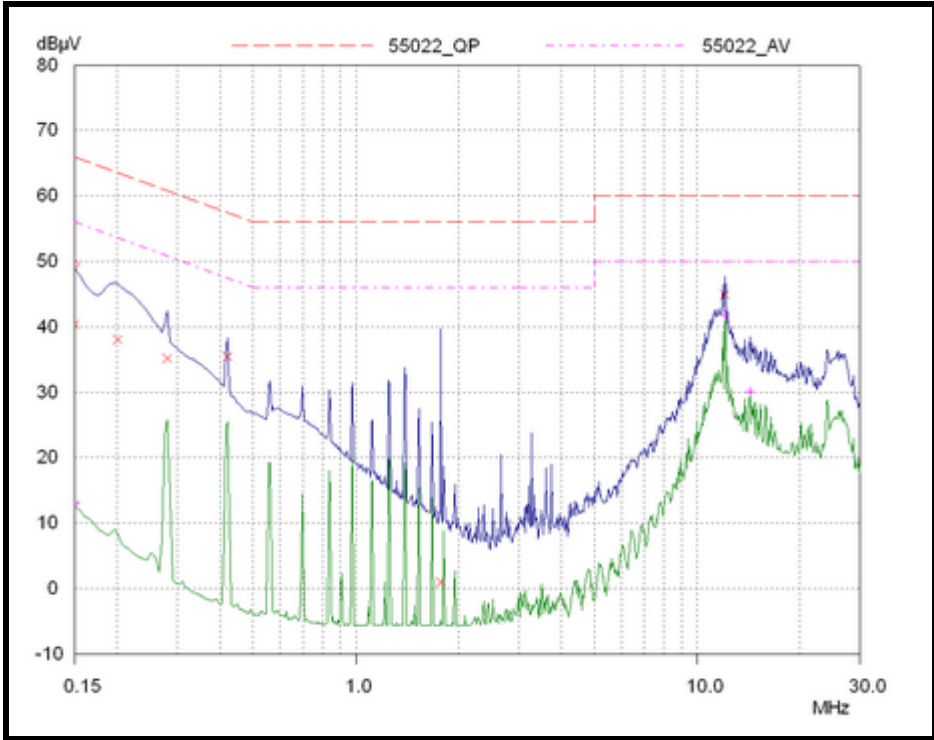

PLCE - EUT Receiving Neutral Line

Appendix C: Additional Test and Sample Details

This appendix contains details of:

1. The samples submitted for testing.
2. Details of EUT operating mode(s)
3. Details of EUT configuration(s) (see below).
4. EUT arrangement (see below).

Throughout testing, the following numbering system is used to identify the sample and it's modification state:

Sample No: Sxx Mod w

where:

xx	= sample number	eg. S01
w	= modification number	eg. Mod 2

The following terminology is used throughout the test report:

Support Equipment (SE) is any additional equipment required to exercise the EUT in the applicable operating mode. Where relevant SE is divided into two categories:

SE in test environment: The SE is positioned in the test environment and is not isolated from the EUT (e.g. on the table top during REFE testing).

SE isolated from the EUT: The SE is isolated via filtering from the EUT. (e.g. equipment placed externally to the ALSR during REFE testing).

EUT configuration refers to the internal set-up of the EUT. It may include for example:

- Positioning of cards in a chassis.
- Setting of any internal switches.
- Circuit board jumper settings.
- Alternative internal power supplies.

Where no change in EUT configuration is **possible**, the configuration is described as "single possible configuration".

EUT arrangement refers to the termination of EUT ports / connection of support equipment, and where relevant, the relative positioning of samples (EUT and SE) in the test environment.

For further details of the test procedures and general test set ups used during testing please refer to the related document "EMC Test Methods - An Overview", which can be supplied by TRaC Telecoms & Radio upon request.

C1) Test samples

The following samples of the apparatus were submitted by the client for testing :

Sample No.	Description	Identification
S04	ETRX357HR Module	None
S07	ETRX357HR Module	None
S13	ETRX357 Module	None

C2) EUT Operating Mode During Testing.

During testing, the EUT was exercised as described in the following tables :

Test	Description of Operating Mode: Transmit
All tests, except as described below	The EUT was transmitting on maximum power using O-QPSK with half-sine pulse-shaping - 8-symbol listen-before send for CSMA-CA - Bit rate 250kb/s, symbol rate 62.5ksymbol/s with 4-bit 16-ary orthogonal symbols, chip rate 2000kchip/s) modulation at centre frequencies $F_c = 2405 + 5 (k - 11)$ in MHz
Test	Description of Operating Mode: Receive/Standby mode
Receiver Radiated Spurious Emissions Receiver Power Line Conducted Emissions	The EUT was placed in continuous receive mode during the test.

C3) EUT Configuration Information.

The EUT was submitted for testing in one single possible configuration.

C4) List of EUT Ports

The tables below describe the termination of EUT ports:

The table below describes the termination of EUT ports:

Sample : All
Tests : All Tests in this report

Port	Description of Cable Attached	Cable length	Equipment Connected
USB	4 Core Screened	1.5 m	Laptop

C5 Details of Equipment Used

For Radiated Measurements:

TRAC Ref	Type	Description	Manufacturer	Date Calibrated.
TRLUH281	FSU46	Spectrum Analyser	Rhode & Schwarz	28/10/2008
TRL138	3115	1-18GHz Horn Antenna	EMCO	23/05/2007
TRL139	3115	1-18GHz Horn Antenna	EMCO	23/05/2007
TRL572	8499B	1 – 26.5 GHz Pre Amplifier	Agilent	04/07/2008
TRLUH186	ESHS10	Receiver	Rhode & Schwarz	03/04/2009
TRLUH191	CBL611/A	BiLog Periodic Antenna	York	01/10/2008
TRLUH28	UHALP 9108	Bicone elements	Schwarzbeck	30/05/2007
TRLUH29	VHBA	Log Periodic Antenna	Schwarzbeck	06/05/2007
TRL193	VHA 193 blau	Bicone elements	Chase	06/05/2008
TRL203	UPA6108	Log Periodic Antenna	Chase	06/05/2008
TRLUH372	6201-69	30MHz – 1 GHz Pre Amplifier	Watkins Johnson	27/11/2008
TRLUH340	83630B	Signal Generator	HP	03/06/2009
REF838	N4010A	Wireless Connectivity Test Set	Agilent	Ref Only

For Conducted Measurements

TRAC Ref	Type	Description	Manufacturer	Date Calibrated.
TRLUH281	FSU46	Spectrum Analyser	Rhode & Schwarz	28/10/2008
REF838	N4010A	Wireless Connectivity Test Set	Agilent	Ref Only

For Power Line Conducted Emissions

TRAC Ref	Type	Description	Manufacturer	Date Calibrated.
TRLUH187	ESHS 10	Receiver	Rhode & Schwarz	10/12/2009
TRLUH195	ESH3-Z5.831.5518.52	LISN	Rhode & Schwarz	09/01/2009
TRLUH21	Cable	3m Canle	TRaC	19/03/2009

Appendix D:**Additional Information**

The following additional information is included within this test report.

D.1 Data sheet for Antenova Rufa 2.4GHz SMD Antenna (ETRX357)



Rufa 2.4 GHz SMD Antenna

Part No. 3030A5839 / 3030A5887 Product Specification

1 Features

- Designed for 2.4 GHz applications: Bluetooth®, Wi-Fi® (802.11b/g), ZigBee®, etc.
- Easy to integrate
- Low profile design for use with no ground beneath the antenna
- High efficiency
- Light weight
- Intended for SMD mounting
- Supplied in tape on reel

2 Description

Rufa is intended for use with all 2.4 GHz applications. The antenna uses a ground plane in order to radiate efficiently, but this ground plane must not extend underneath the antenna itself.

The antenna is available in two versions with the feed locations on the right or left hand side of the antenna.

3 Applications

- Mobile phones
- PDAs
- PNDs
- Headsets
- PMPs / MP3s
- Laptops
- PC-Cards
- Sensors



Integrated Antenna and RF Solutions

1
Product Specification AE020157-M

Rufa 2.4 GHz SMD Antenna
Part No. 3030A5839 / 3030A5887

4 Part numbers

Rufa Left: 3030A5839-01



Rufa Right: 3030A5887-01



5 General data

Product name	Rufa 2.4 GHz
Part Number	3030A5839-01 (Left) 3030A5887-01 (Right)
Frequency	2.4 – 2.5 GHz
Polarization	Linear
Operating temperature	-40 °C to +85 °C
Impedance with matching	50 Ω
Weight	0.1 g
Antenna type	SMD
Dimensions	12.8 x 3.9 x 1.1 [mm]

6 Electrical characteristics

	Typical performance	Conditions
Peak gain	2.1 dBi	All data measured on Antenova's reference boards, part numbers AN-1-0543-1 and AN-1-0556-1 Data given for the 2.4 – 2.5 GHz frequency range
Average gain	-1.2 dBi	
Average efficiency	75%	
Maximum Return Loss	-11 dB	
Maximum VSWR	1.8:1	

Integrated Antenna and RF Solutions

2

Product Specification AE020157-M

Rufa 2.4 GHz SMD Antenna
Part No. 3030A5839 / 3030A5887

7 Electrical performance

7-1 Return Loss

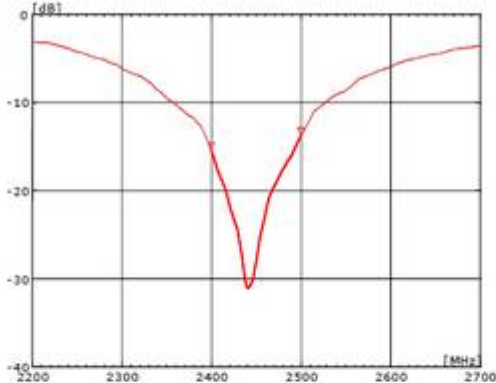

7-2 VSWR

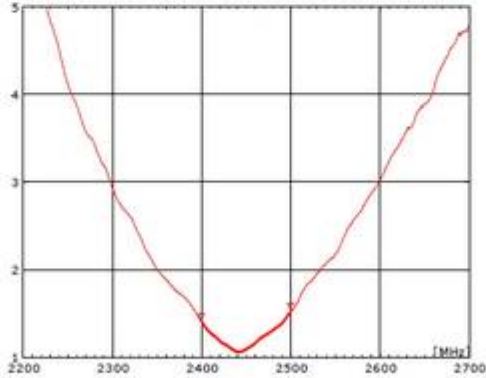

Integrated Antenna and RF Solutions

3
Product Specification AE020157-M

Rufa 2.4 GHz SMD Antenna
Part No. 3030A5839 / 3030A5887

7-3 Antenna patterns

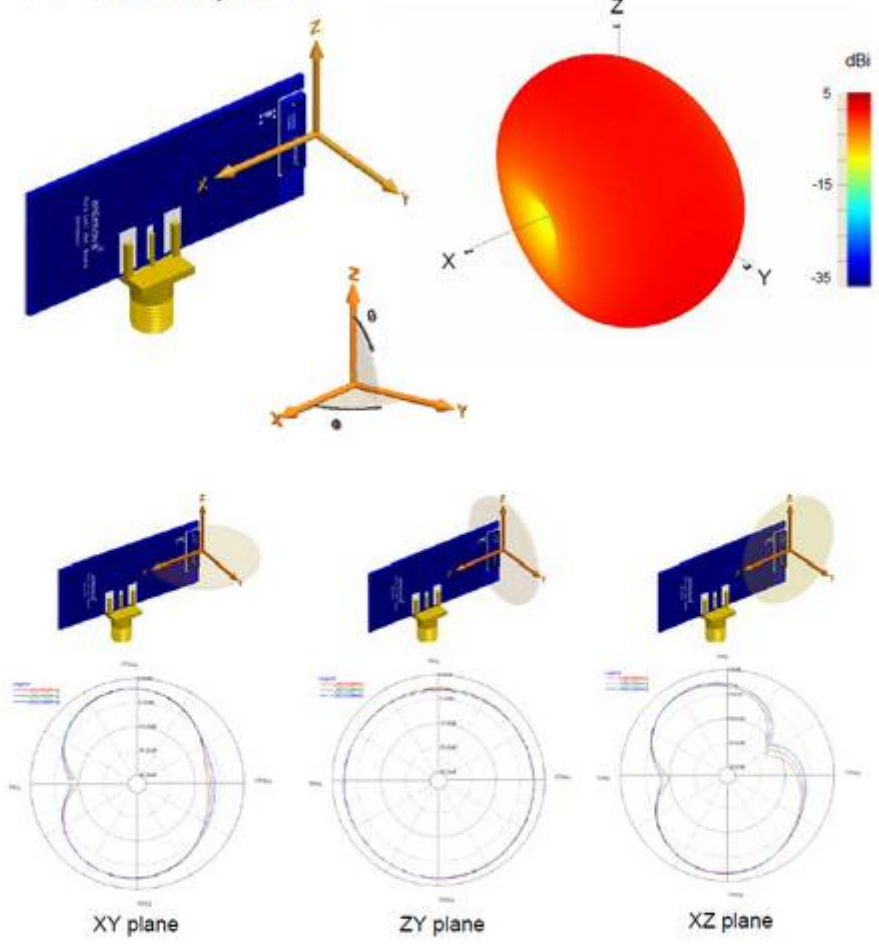

Patterns show combined polarisations
measured on reference board AN-1-0556-1

Integrated Antenna and RF Solutions

4
Product Specification AE020157-M

Rufa 2.4 GHz SMD Antenna
Part No. 3030A5839 / 3030A5887

8 Antenna dimensions

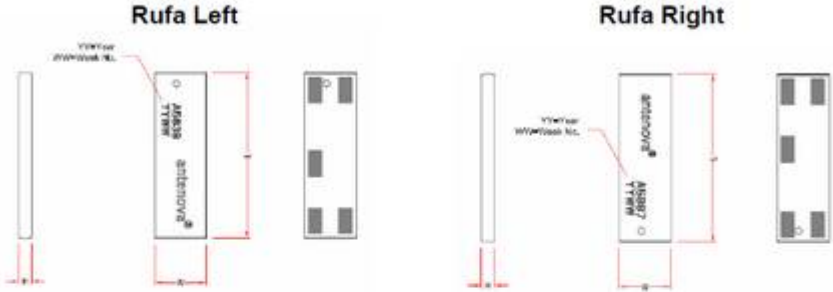

L	W	H
Length	Width	Height
12.8 ± 0.2	3.9 ± 0.2	1.1 ± 0.2

Dimensions in mm

9 Antenna footprint

Rufa Left (Part No: 3030A5839-01) Rufa Right (Part No: 3030A5887-01)
* CAD files of the antenna footprint are available from Antenova on request.

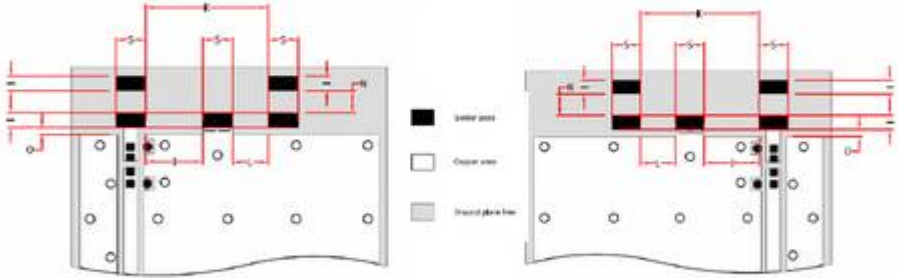

Please contact info@antenova.com for further details.

I	S	K	J	N	L	O
1.0 ± 0.1	2.0 ± 0.1	8.1 ± 0.1	3.7 ± 0.1	1.5 ± 0.1	2.4 ± 0.1	0.5 ± 0.1

Dimensions in mm

Integrated Antenna and RF Solutions

Rufa 2.4 GHz SMD Antenna
Part No. 3030A5839 / 3030A5887

10 Electrical interface

10-1 Transmission lines

- All transmission lines should be designed to have a characteristic impedance of 50 Ω
- The length of the transmission lines should be kept to a minimum
- Any other parts of the RF system like transceivers, power amplifiers, etc, should also be designed to have an impedance of 50 Ω

Once the material for the PCB has been chosen (PCB thickness and dielectric constant), a coplanar transmission line can easily be designed using any of the commercial software packages for transmission line design. For the chosen PCB thickness, copper thickness and substrate dielectric constant, the program will calculate the appropriate transmission line width and gaps on either side of the track so the characteristic impedance of the coplanar transmission line is 50 Ω .

10-2 Matching circuit

The antenna requires a matching circuit that must be optimized for each customer's product. The matching circuit will require up to three components and the following pad layout should be designed into the device so the correct circuit can be installed:

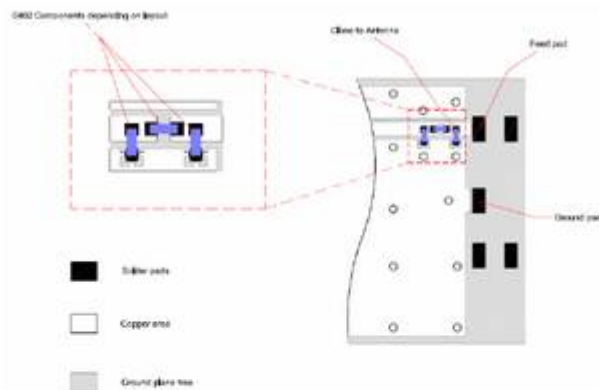

The antenna feed pad and the antenna ground pad are indicated in the drawing above. Additional pads are for mechanical attachment only and should not be grounded.

Integrated Antenna and RF Solutions

6

Product Specification AE020157-M

Rufa 2.4 GHz SMD Antenna
Part No. 3030A5839 / 3030A5887

In addition to the matching circuit, a separate DC blocking capacitor will also be required between the radio and the antenna matching circuit.

Note: The component values for the matching circuit will vary depending on the size of the PCB and surrounding components. The impedance of the antenna should be measured before selecting suitable matching components. Antenova offers this service on request. Contact info@antenova.com for further information.

10-3 Antenna placement

Antenova strongly recommends placing the antenna near the edge of the board. Maximum antenna performance is achieved by placing the antenna towards one of the corners of the PCB and with the feed point of the antenna as close to same corner of the PCB as possible.

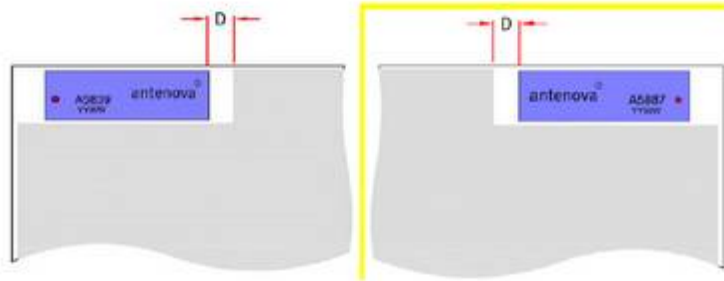

Additional ground and components near the antenna should be at a distance of at least 2 mm. Where possible the antenna should be clear of ground from both sides, although the antenna can work well with a minimum clearance of $D \geq 2$ mm as shown in the drawing above.

Integrated Antenna and RF Solutions

7
Product Specification AE020157-M

Rufa 2.4 GHz SMD Antenna
Part No. 3030A5839 / 3030A5887

10-4 Reference boards

The reference boards have been designed for evaluation purposes of Rufa 2.4 GHz and they include a SMA female connector

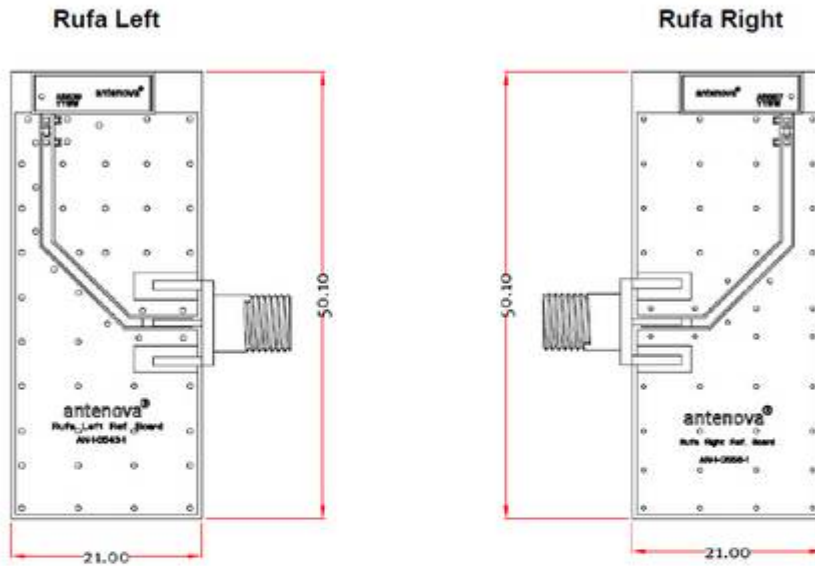

Dimensions in mm

To order a reference board contact info@antenna.com

Integrated Antenna and RF Solutions

8

Product Specification AE020157-M

Rufa 2.4 GHz SMD Antenna
Part No. 3030A5839 / 3030A5887

11 Soldering

This antenna is suitable for lead free soldering.

The reflow profile should be adjusted to suit the device, oven and solder paste, while observing the following conditions:

- The maximum temperature should not exceed 240 °C
- However for lead free soldering, a maximum temperature of 255 °C for no more than 20 seconds is permitted.
- The antenna should not be exposed to temperatures exceeding 120 °C more than 3 times during the soldering process.

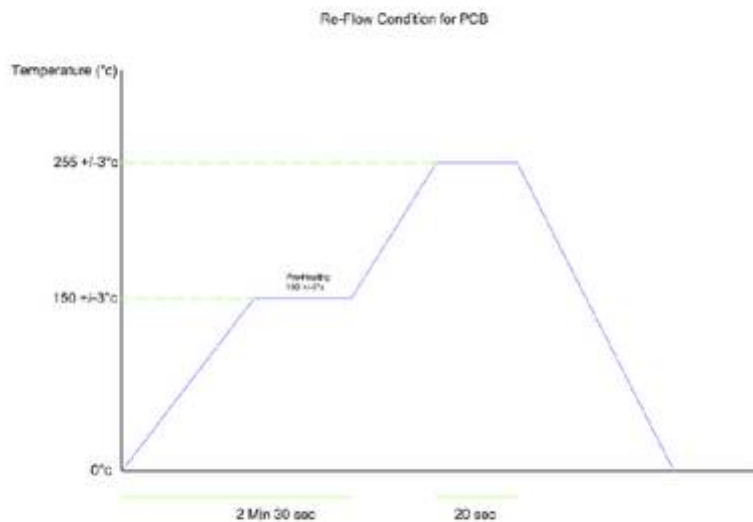

12 Hazardous material regulation conformance

The antenna has been tested to conform to RoHS requirements. A certificate of conformance is available from Antenova's website.

Integrated Antenna and RF Solutions

9
Product Specification AEG20157-M

Rufa 2.4 GHz SMD Antenna
Part No. 3030A5839 / 3030A5887

13 Packaging

13-1 Optimal storage conditions for packaged reels

Temperature	-10°C to 40°C
Humidity	Less than 75% RH
Shelf Life	18 Months
Storage place	Away from corrosive gas and direct sunlight
Packaging	Reels should be stored in unopened sealed manufacturer's plastic packaging.

Note: Storage of open reels of antennas is not recommended due to possible oxidization of pads on antennas. If short term storage is necessary, then it is highly recommended that the bag containing the antenna reel is re-sealed and stored in like storage conditions as in above table.

Integrated Antenna and RF Solutions

Rufa 2.4 GHz SMD Antenna
 Part No. 3030A5839 / 3030A5887

13-2 Tape characteristics

Rufa Left
 [Part Number: 3030A5839-01]

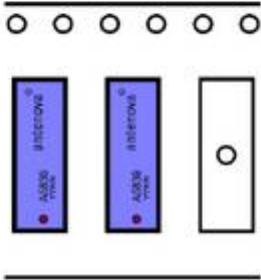
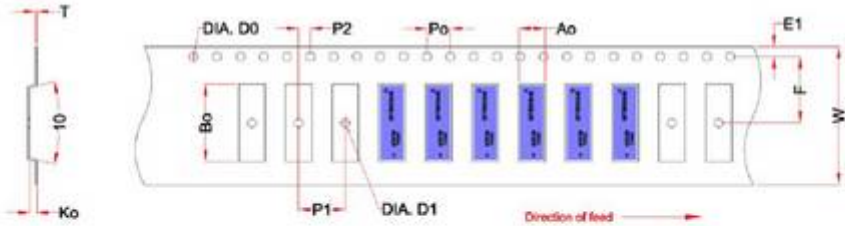

W	F	E1	P0	P1	P2	A0	B0	K0	T	D0	D1
24 ± 0.2	11.5 ± 0.1	1.75 ± 0.1	4 ± 0.1	8 ± 0.1	2 ± 0.1	4.3 ± 0.1	13.1 ± 0.1	1.4 ± 0.1	0.3 ± 0.05	Min 1.5	Min 1.5

Dimensions in mm

Quantity	Leading Space	Trailing Space
1000 pcs / reel	50 blank antenna holders	37 blank antenna holders

Integrated Antenna and RF Solutions

Rufa 2.4 GHz SMD Antenna
Part No. 3030A5839 / 3030A5887

Rufa Right
[Part Number: 3030A5887-01]

W	F	E1	P0	P1	P2	A0	B0	K0	T	D0	D1
24 ± 0.2	11.5 ± 0.1	1.75 ± 0.1	4 ± 0.1	8 ± 0.1	2 ± 0.1	4.3 ± 0.1	13.1 ± 0.1	1.4 ± 0.1	0.3 ± 0.05	Min 1.5	Min 1.5

Dimensions in mm

Quantity	Leading Space	Trailing Space
1000 pos / reel	50 blank antenna holders	37 blank antenna holders

Integrated Antenna and RF Solutions

12
Product Specification AED20157-M

Rufa 2.4 GHz SMD Antenna
Part No. 3030A5839 / 3030A5887

13-3 Reel dimensions

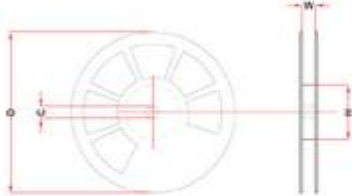

Width (W)	Reel Diameter (D)	Hub Diameter (H)	Shaft Diameter (C)
24 mm	180 mm (7")	60 mm (2")	13 mm

13-4 Box dimensions



Width (W)	Breadth (B)	Thickness (H)
203 mm	188 mm	40 mm

13-5 Bag properties

Reels are supplied in protective plastic packaging

13-6 Reel label information

Rufa Left



Rufa Right



Dimensions in mm

Integrated Antenna and RF Solutions

Rufa 2.4 GHz SMD Antenna
Part No. 3030A5839 / 3030A5887



www.antenova.com

Corporate Headquarters

Antenova Ltd.
Far Field House
Albert Road
Stow-cum-Quy
Cambridge
CB25 9AR

Tel: +44 1223 810600
Fax: +44 1223 810650
Email: info@antenova.com

North America Headquarters

Antenova Ltd.
Rogers Business Park
2541 Technology Drive Suite 403
Elgin, IL 60124

Tel: +1 (847) 551 9710
Fax: +1 (847) 551 9719
Email: info@antenova.com

Asia Headquarters

Antenova Asia Ltd.
4F, No. 324, Sec. 1, Nei-Hu Road
Nei-Hu District
Taipei 11493
Taiwan, ROC

Tel: +886 (0) 2 8797 8630
Fax: +886 (0) 2 8797 6890
Email: info@antenova.com

Copyright © 2008 Antenova Ltd. All Rights Reserved. Antenova® and gigaNOVA® are trademarks of Antenova Ltd. Any other names and/or trademarks belong to their respective companies.

The materials provided herein are believed to be reliable and correct at the time of print. Antenova does not warrant the accuracy or completeness of the information, text, graphics or other items contained within these information. Antenova further assumes no responsibility for the use of this information, and all such information shall be entirely at the user's risk.



Integrated Antenna and RF Solutions

14
Product Specification AE020157-M

D.2 Data sheet for EAD Ltd BT-Stubby Antenna (ETRX357HR Option 1)

Product Specification



BT-Stubby

2.4 GHz 1/4 Wave
Stubby Antenna

Features

- 1/4 Wave Stubby Antenna
- Right Angle SMA Connector
- Groundplane Dependent
- Ideal for fixed and mobile devices

Specifications	
Radiating element	1/4 Wave Helical
Frequency range	2.4 - 2.5 GHz
Peak gain	0 dBi
Polarisation	Linear
Return Loss	-12 dB
Impedance	50 Ohm
Cable / Connector	SMA-Male
Dimensions	36 x 17.5 mm (max)

Ordering Options	
FBT535024-SM-RA	BT-Stubby with SMA-Male RA Connector

Specifications subject to change without notice.

5 Little Balmer
Buckingham Industrial Park
Buckingham
MK18 1TF
UK

Tel: +44 (0)1280 824055
Fax: +44 (0)1280 817179
Email: sales@ead-ltd.com
Web: www.ead-ltd.com



embedded antenna design ltd
Delivering Antenna Innovation



www.ead-ltd.com

BT-Stubby | 2.4 GHz Stubby RA Antenna

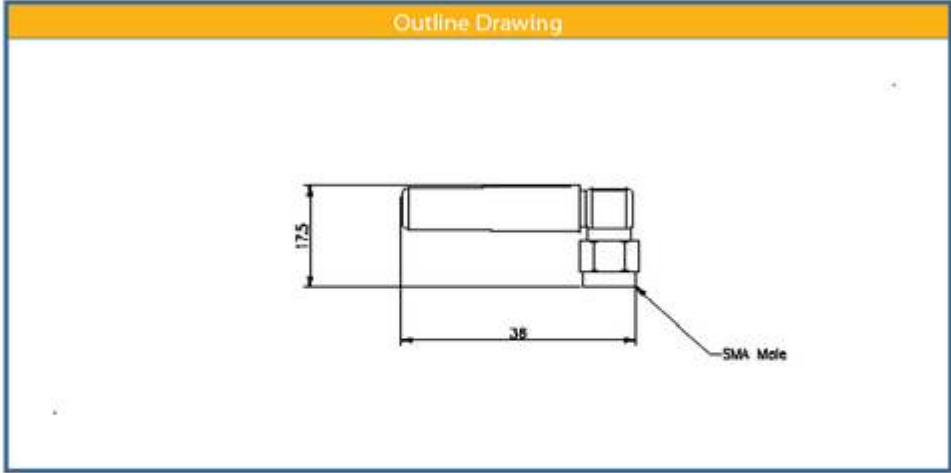

Specifications subject to change without notice.

5 Little Balmer
 Buckingham Industrial Park
 Buckingham
 MK18 1TF
 UK

Tel: +44 (0)1280 824055
 Fax: +44 (0)1280 817179
 Email: sales@ead-ltd.com
 Web: www.ead-ltd.com



D.2 Data sheet for Wellhope WH-2400-U2.5 Antenna (ETRX357HR Option 2)



Wellhope communication equipment factory

price:

5000PCS delivery time 10day	10K delivery time 14day	25K delivery time 14day
US\$1.75	US\$1.6	US\$1.5

Model	WH-2400-U2.5
Main Technical pecfications	
Frequency	2400-2483MHZ
Bandwidth	83MHz
VSWR	≤1.8
Gain	2.5 dBi
Polarizatio Type	Vertical
Rated Power	50w
Input Impedcion	50Ω
Connector Type	U.FL
Cable length	10cm
Dimensions	Φ8×80(mm)
Weight	15g



www.wellhope-wireless.com wh@wellhope-wireless.com
ADD:No.10, Wenming road SanShui District FoShan City, Guangdong , China

D.2 Declaration of difference between ETRX351 and ETRX 357 Series Modules

The following is an extract from a client email detailing the difference between the ETRX351 and ETRX357 series modules.

-----Original Message-----

From: Marius Munder [<mailto:marius.munder@telegesis.com>]

Sent: 16 March 2010 17:13

To: Geoff Cruickshank

Subject: Re: FW: RE: Other documents Telegesis

Hi Geoff,

"Both chips are identical with the one exception that the EM351 has 128kB of flash and the EM357 has 192kB of flash"

Would this be sufficient?

Best Regards,
Marius

Appendix E:**Calculation of the duty cycle correction factor**

The duty cycle correction factor to be applied to measurements made using an average detector is calculated in the Spreadsheet "**Duty_Cycle_for_TX_calc.xls**" presented as a separate exhibit to this report.

The calculated Correction factor (dB) = $20 \times (\text{Log}_{10} 0.27) = -11.4\text{dB}$

Appendix F:

Photographs and Figures

The following photographs were taken of the test samples:

1. Radiated electric field emissions arrangement: front view.
2. Radiated electric field emissions arrangement: close up.
3. Power line conducted emissions



Photograph 1



Photograph 2

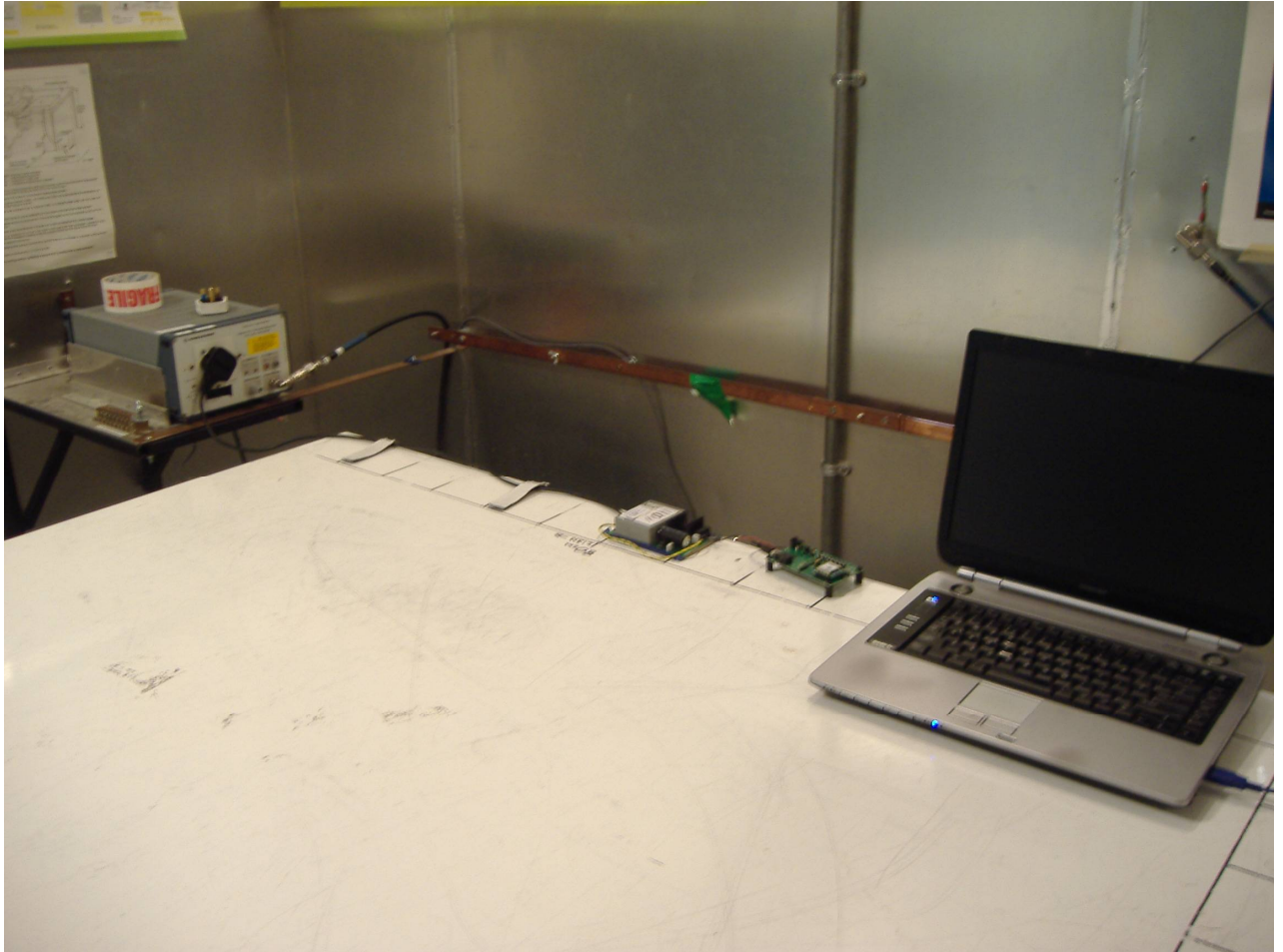

Photograph 3

Appendix G:**MPE Calculation**

OET Bulletin No. 65, Supplement C 01-01

47 CFR §§1.1307 and 2.1091

2.1091 Radio frequency radiation exposure evaluation: mobile devices.

For purposes of these requirements mobile devices are defined by the FCC as transmitters designed to be used in other than fixed locations and to generally be used in such a way that a separation distance of at least 20 centimetres is normally maintained between radiating structures and the body of the user or nearby persons. These devices are normally evaluated for exposure potential with relation to the MPE limits. As the 20cm separation specified under FCC rules may not be achievable under normal operation of the EUT, an RF exposure calculation is needed to show the minimum distance required to be less than 1mW/cm² power density limit, as required under FCC rules.

Prediction of MPE limit at a given distance

Equation from page 18 of OET Bulletin 65, Edition 97-01

$$S = \frac{EIRP}{4 \pi R^2} \text{ re - arranged} \quad R = \sqrt{\frac{EIRP}{S 4 \pi}}$$

where:

S = power density

R = distance to the centre of radiation of the antenna

EIRP = EUT Maximum power

Note:

The EIRP measurement was performed using the peak conducted power measurement in conjunction with the maximum declared antenna gain.

Result

Prediction Frequency (MHz)	Maximum EIRP (mW)	Power density limit (S) (mW/cm ²)	Distance (R) cm required to be less than 1mW/cm ²
2445	11.9	1	0.97

