

SHYAM	SHYAM TELECOM MANUFACTURING LIMITED
PRODUCTION TEST PROCEDURE	HB-20-1900
	PART CODE:

5.0 Test Procedure:

5.1 RF Test:

5.2.1 Initial Test Equipment Settings

5.2.1.1 Gain:

5.2.1.2 Regulated DC Power Supply:

Set the Regulated DC Power Supply to output +9.0V DC and current of around 5A

5.2.1.3 Spectrum Analyzer:

Center Frequency: Frequency of Operation of UUT

Span: 500KHz

RBW: 1KHz

VBW: 100Hz

5.2.1.4 Signal Generator:

Center Frequency: Frequency of Operation of UUT

Modulation: OFF

Power Level: As per requirement (less than -50dBm)

5.2.1.5 Network Analyzer:

Center Frequency: Frequency of Operation of UUT

Span: 200 MHz

Power Level: -50 dBm

Scale Reference (at RFL Port) 10dB

Scale reference (at TRN Port): 30dB

Reference Position (at RFL Port): -30dB

Reference position (at TRN port): -10dB

Markers: As per our Interest.

5.2.1.2 Noise Figure:

Start Frequency: Start frequency of Band under Testing

Stop Frequency: End frequency of Band Under Testing

Increment: 1 MHz /0.5 MHz

Version.	R00				
Change Note No.					
Issue Date					
Changed By:	Kamesh.				
Approved By					

Document Custodian:

Doc. No.:

Version: R00

Issue Date:

SHYAM	SHYAM TELECOM MANUFACTURING LIMITED				
PRODUCTION TEST PROCEDURE	HB-20-1900				
	PART CODE:				

5.2.2 Test Setup Diagram:

5.2.2.1 With Signal Generator and Spectrum Analyzer:

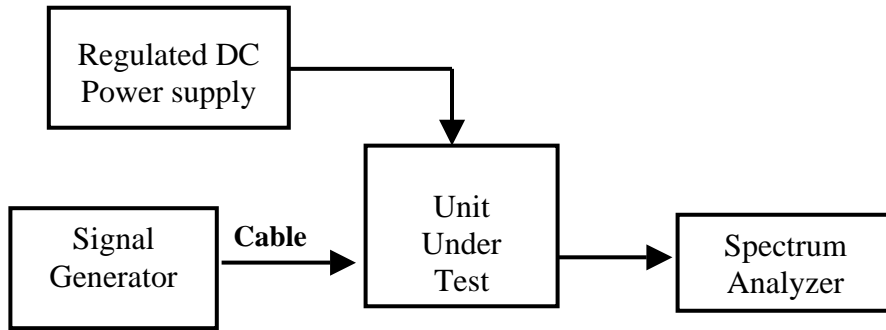

5.2.2.2 With Network Analyzer:

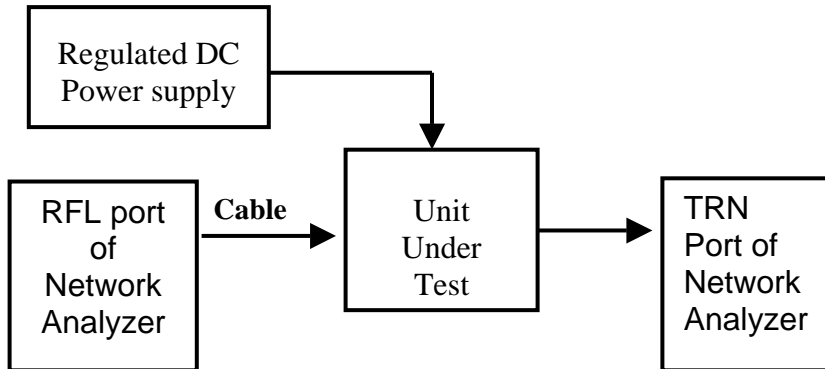

Version.	R00				
Change Note No.					
Issue Date					
Changed By:	Kamesh.				
Approved By					

Document Custodian:

Doc. No.:

Version: R00

Issue Date:

SHYAM	SHYAM TELECOM MANUFACTURING LIMITED
PRODUCTION TEST PROCEDURE	HB-20-1900
	PART CODE:

5.2.2.3 With Noise Figure Meter:

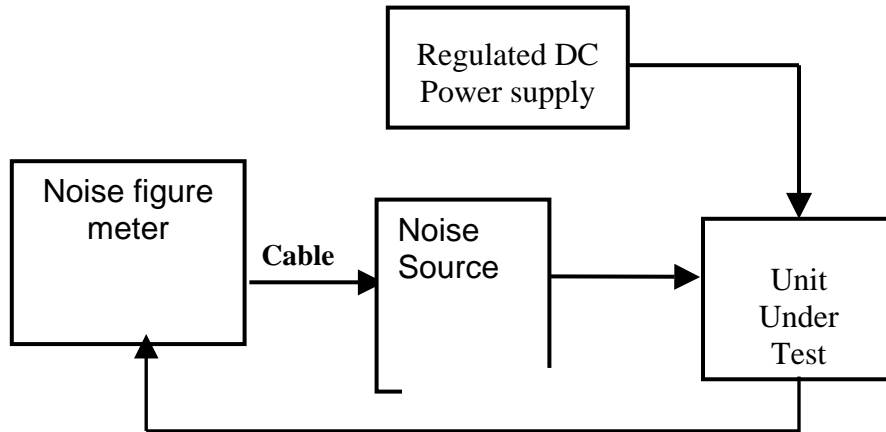

5.2.3 Gain Measurement:

(Note: Refer to the Initial test equipment setting before proceeding)

- 5.2.3.1 Calibrate the equipment and cables used.
- 5.2.3.2 Set the power Level of the signal generator to less than -50 dBm
- 5.2.3.3 Switch on the regulated DC Power Supply and the equipment
- 5.2.3.4 Set the Frequency of the signal Generator to the start frequency of band under test.
- 5.2.3.5 Set the span, VBW, RBW of the spectrum analyzer to the set frequency in signal generator
- 5.2.3.6 Connect the UUT as per the test setup diagram shown above
- 5.2.3.7 Note down the output power level at the Spectrum Analyzer.
- 5.2.3.8 Increment the signal generator frequency by 5 MHz
- 5.2.3.9 Repeat steps from iv to vi until the signal generator frequency reaches the end frequency of band under test.
- 5.2.3.10 Increment the power level of the signal generator by 5dB
- 5.2.3.11 Repeat the steps iv to Viii until the power level reaches 10dBm.
- 5.2.3.12 Switch OFF the power supply and the equipment.

Version.	R00				
Change Note No.					
Issue Date					
Changed By:	Kamesh.				
Approved By					

Document Custodian:

Doc. No.:

Version: R00

Issue Date:

SHYAM PRODUCTION TEST PROCEDURE	SHYAM TELECOM MANUFACTURING LIMITED				
	HB-20-1900				
	PART CODE:				

5.2.4 Flow Chart For Testing:

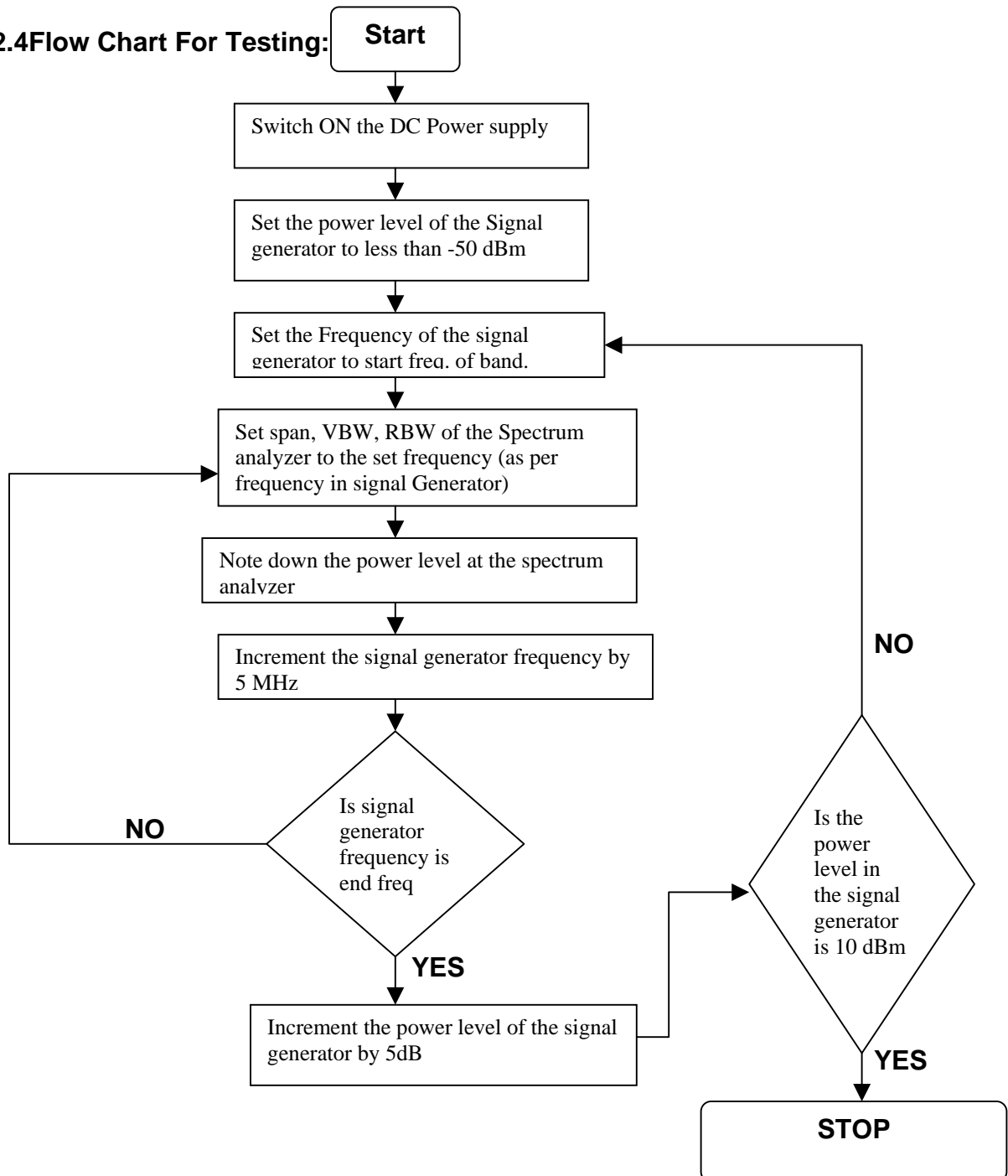

Version.	R00				
Change Note No.					
Issue Date					
Changed By:	Kamesh.				
Approved By					

Document Custodian:
Doc. No.:

Version: R00

Issue Date:

SHYAM	SHYAM TELECOM MANUFACTURING LIMITED
PRODUCTION TEST PROCEDURE	HB-20-1900
	PART CODE:

5.2.5 Precautions to be taken while Testing:

5.2.5.1 Always check the resistance between supply and ground before powering up any section. (This ensures DC short circuit)

5.2.5.2 Always put attenuating pads at the input and output of testing section. This ensures proper termination.

5.2.5.3 Do not solder any part or line while the system is ON.

Version.	R00				
Change Note No.					
Issue Date					
Changed By:	Kamesh.				
Approved By					

Document Custodian:

Doc. No.:

Version: R00

Issue Date: