

ENGINEERING TEST REPORT

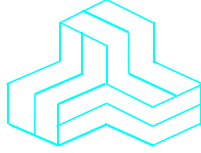

IXM WIFIBT
Model: IXM010
FCC ID: S38-WIFIBT

Applicant:

Invixium Access Inc.
#5 – 205 Riviera Drive
Markham, Ontario
Canada L3R 5J8

In Accordance With

Federal Communications Commission (FCC)
Part 15, Subpart C, Section 15.247
Digital Modulation Systems (DTS) Operating in 2400 – 2483.5 MHz Band

UltraTech's File No.: 15INVX029_FCC15C247W

This Test report is Issued under the Authority of
Tri M. Luu
Vice President of Engineering
UltraTech Group of Labs

Date: August 5, 2015

Report Prepared by: Dan Huynh

Tested by: Hung Trinh

Issued Date: August 5, 2015

Test Dates: March 20 - April 7, 2014

- *The results in this Test Report apply only to the sample(s) tested, and the sample tested is randomly selected.*
- *This report must not be used by the client to claim product endorsement by NVLAP or any agency of the US Government.*

UltraTech

3000 Bristol Circle, Oakville, Ontario, Canada, L6H 6G4
Tel.: (905) 829-1570 Fax.: (905) 829-8050
Website: www.ultratech-labs.com, Email: vic@ultratech-labs.com, Email: tri@ultratech-labs.com



91038



1309



46390-2049



NVLAP LAB
CODE 200093-0



SL2-IN-E-
1119R



CA2049



TL363_B



TPTDP
DA1300

TABLE OF CONTENTS

EXHIBIT 1. INTRODUCTION..... 1

1.1. SCOPE 1

1.2. RELATED SUBMITTAL(S)/GRANT(S)..... 1

1.3. NORMATIVE REFERENCES 1

EXHIBIT 2. PERFORMANCE ASSESSMENT..... 2

2.1. CLIENT INFORMATION 2

2.2. EQUIPMENT UNDER TEST (EUT) INFORMATION 2

2.3. EUT’S TECHNICAL SPECIFICATIONS 3

2.4. ASSOCIATED ANTENNA DESCRIPTIONS 3

2.5. LIST OF EUT’S PORTS 3

2.6. ANCILLARY EQUIPMENT 3

EXHIBIT 3. EUT OPERATING CONDITIONS AND CONFIGURATIONS DURING TESTS..... 4

3.1. CLIMATE TEST CONDITIONS 4

3.2. OPERATIONAL TEST CONDITIONS & ARRANGEMENT FOR TESTS 4

EXHIBIT 4. SUMMARY OF TEST RESULTS 5

4.1. LOCATION OF TESTS 5

4.2. APPLICABILITY & SUMMARY OF EMC EMISSION TEST RESULTS 5

4.3. MODIFICATIONS INCORPORATED IN THE EUT FOR COMPLIANCE PURPOSES 5

EXHIBIT 5. TEST DATA 6

5.1. POWER LINE CONDUCTED EMISSIONS [§15.207(A)]..... 6

5.2. OCCUPIED BANDWIDTH [§ 15.247(A)(2)]..... 15

5.3. PEAK CONDUCTED OUTPUT POWER - DTS [§ 15.247(B)(3)] 50

5.4. TRANSMITTER BAND-EDGE & SPURIOUS CONDUCTED EMISSIONS [§ 15.247(D)] 52

5.5. TRANSMITTER SPURIOUS RADIATED EMISSIONS AT 3 METERS [§§ 15.247(D), 15.209 & 15.205] 88

5.6. POWER SPECTRAL DENSITY [§ 15.247(E)] 94

5.7. RF EXPOSURE REQUIRMENTS [§§ 15.247(E)(I), 1.1310 & 2.1091] 113

EXHIBIT 6. TEST EQUIPMENT LIST 115

EXHIBIT 7. MEASUREMENT UNCERTAINTY 116

7.1. LINE CONDUCTED EMISSION MEASUREMENT UNCERTAINTY 116

7.2. RADIATED EMISSION MEASUREMENT UNCERTAINTY 116

EXHIBIT 1. INTRODUCTION

1.1. SCOPE

Reference:	FCC Part 15, Subpart C, Section 15.247
Title:	Code of Federal Regulations (CFR), Title 47 – Telecommunication, Part 15 – Radio Frequency Devices
Purpose of Test:	Equipment Certification for Digital Modulation Systems (DTS) Transmitter Operating in the Frequency Band 2400-2483.5 MHz.
Test Procedures:	<ul style="list-style-type: none"> ▪ ANSI C63.4 ▪ ANSI C63.10 ▪ FCC KDB Publication No. 558074 D01 DTS Meas Guidance v03r01
Environmental Classification:	<input checked="" type="checkbox"/> Commercial, industrial or business environment <input checked="" type="checkbox"/> Residential environment

1.2. RELATED SUBMITTAL(S)/GRANT(S)

None.

1.3. NORMATIVE REFERENCES

Publication	Year	Title
47 CFR Parts 0-19	2014	Code of Federal Regulations (CFR), Title 47 – Telecommunication
ANSI C63.4	2009	American National Standard for Methods of Measurement of Radio-Noise Emissions from Low-Voltage Electrical and Electronic Equipment in the Range of 9 KHz to 40 GHz
ANSI C63.10	2009	American National Standard for Testing Unlicensed Wireless Devices
CISPR 22 & EN 55022	2008-09, Edition 6.0 2006	Information Technology Equipment - Radio Disturbance Characteristics - Limits and Methods of Measurement
CISPR 16-1-1 +A1 +A2	2006 2006 2007	Specification for radio disturbance and immunity measuring apparatus and methods. Part 1-1: Measuring Apparatus
CISPR 16-1-2 +A1 +A2	2003 2004 2006	Specification for radio disturbance and immunity measuring apparatus and methods. Part 1-2: Conducted disturbances
FCC, KDB Publication No. 558074 D01 DTS Meas Guidance v03r01	2013	Guidance for Performing Compliance Measurements on Digital Transmission Systems (DTS) Operating Under §15.247

EXHIBIT 2. PERFORMANCE ASSESSMENT

2.1. CLIENT INFORMATION

Applicant	
Name:	Invixium Access Inc.
Address:	205 Riviera Drive, Unit 5 Markam, ON Canada L3R 5J8
Contact Person:	Shiraz Kapadia Phone #: 647-282-1745 Fax #: N/A Email Address: SKapadia@invixium.com

Manufacturer	
Name:	Mara Technologies Inc.
Address:	5680 14th Avenue Markham, Ontario Canada L3S 3K8
Contact Person:	Matthew Ruscica Phone #: 1-905-201-1787 Fax #: 1-905-201-9114 Email Address: matthew@maratech.ca

2.2. EQUIPMENT UNDER TEST (EUT) INFORMATION

The following information (with the exception of the Date of Receipt) has been supplied by the applicant.

Brand Name:	Invixium Access Inc.
Product Name:	IXM WIFIBT
Model Name or Number:	IXM010
Serial Number:	Test Sample
Type of Equipment:	Digital Transmission System (DTS)
Input Power Supply Type:	External DC Power Supply
Primary User Functions of EUT:	Provide WiFi connectivity (802.11 b/g/n) for Biometric Access Control devices (hosts) manufactured by Invixium Access Inc.

2.3. EUT’S TECHNICAL SPECIFICATIONS

Transmitter	
Equipment Type:	<ul style="list-style-type: none"> • Mobile • Base Station (fixed use)
Intended Operating Environment:	Commercial, industrial or business environment
Power Supply Requirement:	1.8V, 3.3V from a host
RF Output Power Rating:	23.94 dBm (247.742 mW) Peak
Operating Frequency Range:	2412 – 2462 MHz
RF Output Impedance:	50 Ω
Duty Cycle:	100%
Modulation Type:	DSSS, OFDM
Antenna Connector Types:	U.FL

2.4. ASSOCIATED ANTENNA DESCRIPTIONS

Antenna Type	Maximum Gain (dBi)
PCB antenna	2

2.5. LIST OF EUT’S PORTS

Port Number	EUT’s Port Description	Number of Identical Ports	Connector Type	Cable Type (Shielded/Non-shielded)
1	SDIO I/F w/ WiFi, UART I/F w/ BT Power, GND	1	20-pin header (male)	N/A Connects directly to Host Motherboard

2.6. ANCILLARY EQUIPMENT

The EUT was tested while connected to the following representative configuration of ancillary equipment necessary to exercise the ports during tests:

Ancillary Equipment # 1	
Description:	Test Jig
Brand name:	Invizium
Model Name or Number:	IXM SENSE FP1X
Serial Number:	N/A
Connected to EUT’s Port:	20-pin header

EXHIBIT 3. EUT OPERATING CONDITIONS AND CONFIGURATIONS DURING TESTS

3.1. CLIMATE TEST CONDITIONS

The climate conditions of the test environment are as follows:

Temperature:	21 to 23 °C
Humidity:	45 to 58%
Pressure:	102 kPa
Power Input Source:	1.8V, 3.3V from a host

3.2. OPERATIONAL TEST CONDITIONS & ARRANGEMENT FOR TESTS

Operating Modes:	The transmitter was operated in a continuous transmission mode with the carrier modulated as specified in the Test Data.
Special Test Software:	Special software provided by the Applicant to operate the EUT at each channel frequency continuously and in the range of typical modes of operation.
Special Hardware Used:	Test Jig
Transmitter Test Antenna:	The EUT is tested with the antenna fitted in a manner typical of normal intended use as non-integral antenna equipment as described with the test results.

Transmitter Test Signals	
Frequency Band(s):	2412 – 2462 MHz
Frequency(ies) Tested:	2412 MHz, 2437 MHz and 2462 MHz
RF Power Output: (measured maximum output power at antenna terminals)	23.94 dBm (247.742 mW) Peak
Normal Test Modulation:	DSSS, OFDM
Modulating Signal Source:	Internal

EXHIBIT 4. SUMMARY OF TEST RESULTS

4.1. LOCATION OF TESTS

All of the measurements described in this report were performed at Ultratech Group of Labs located in the city of Oakville, Province of Ontario, Canada.

- AC Power Line Conducted Emissions were performed in UltraTech's shielded room, 24'(L) by 16'(W) by 8'(H).
- Radiated Emissions were performed at the Ultratech's 3-10 TDK Semi-Anechoic Chamber situated in the Town of Oakville, province of Ontario. This test site been calibrated in accordance with ANSI C63.4, and found to be in compliance with the requirements of Sec. 2.948 of the FCC Rules. The descriptions and site measurement data of the Oakville 3-10 TDK Semi-Anechoic Chamber has been filed with FCC office (FCC File No.: 91038) and Industry Canada office (Industry Canada File No.: 2049A-3). Expiry Date: 2017-04-02.

4.2. APPLICABILITY & SUMMARY OF EMC EMISSION TEST RESULTS

FCC Section(s)	Test Requirements	Compliance (Yes/No)
15.203	Antenna requirements	Yes*
15.207(a)	AC Power Line Conducted Emissions	Yes
15.247(a)(2)	6 dB Bandwidth	Yes
15.247(b)(3)	Peak Conducted Output Power - DTS	Yes
15.247(d)	Band-Edge and RF Conducted Spurious Emissions at the Transmitter Antenna Terminal	Yes
15.247(d), 15.209 & 15.205	Transmitter Spurious Radiated Emissions	Yes
15.247(e)	Power Spectral Density	Yes
15.247(i), 1.1307, 1.1310, 2.1091	RF Exposure	Yes

* The EUT complies with the requirement; it uses a unique coupling.

4.3. MODIFICATIONS INCORPORATED IN THE EUT FOR COMPLIANCE PURPOSES

None.

EXHIBIT 5. TEST DATA

5.1. POWER LINE CONDUCTED EMISSIONS [§15.207(a)]

5.1.1. Limit(s)

The equipment shall meet the limits of the following table:

Frequency of emission (MHz)	Conducted Limits (dBµV)	
	Quasi-peak	Average
0.15–0.5	66 to 56*	56 to 46*
0.5–5	56	46
5–30	60	50

*Decreases linearly with the logarithm of the frequency

5.1.2. Method of Measurements

ANSI C63.4-2009

5.1.3. Test Arrangement

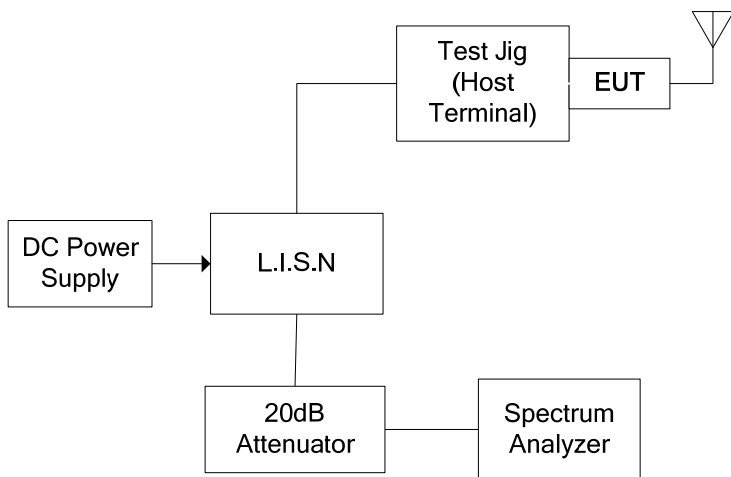

5.1.4. Test Data

Plot 5.1.4.1. Power Line Conducted Emissions; Line Voltage: 12 V DC; Line Tested: Positive, Tx Mode

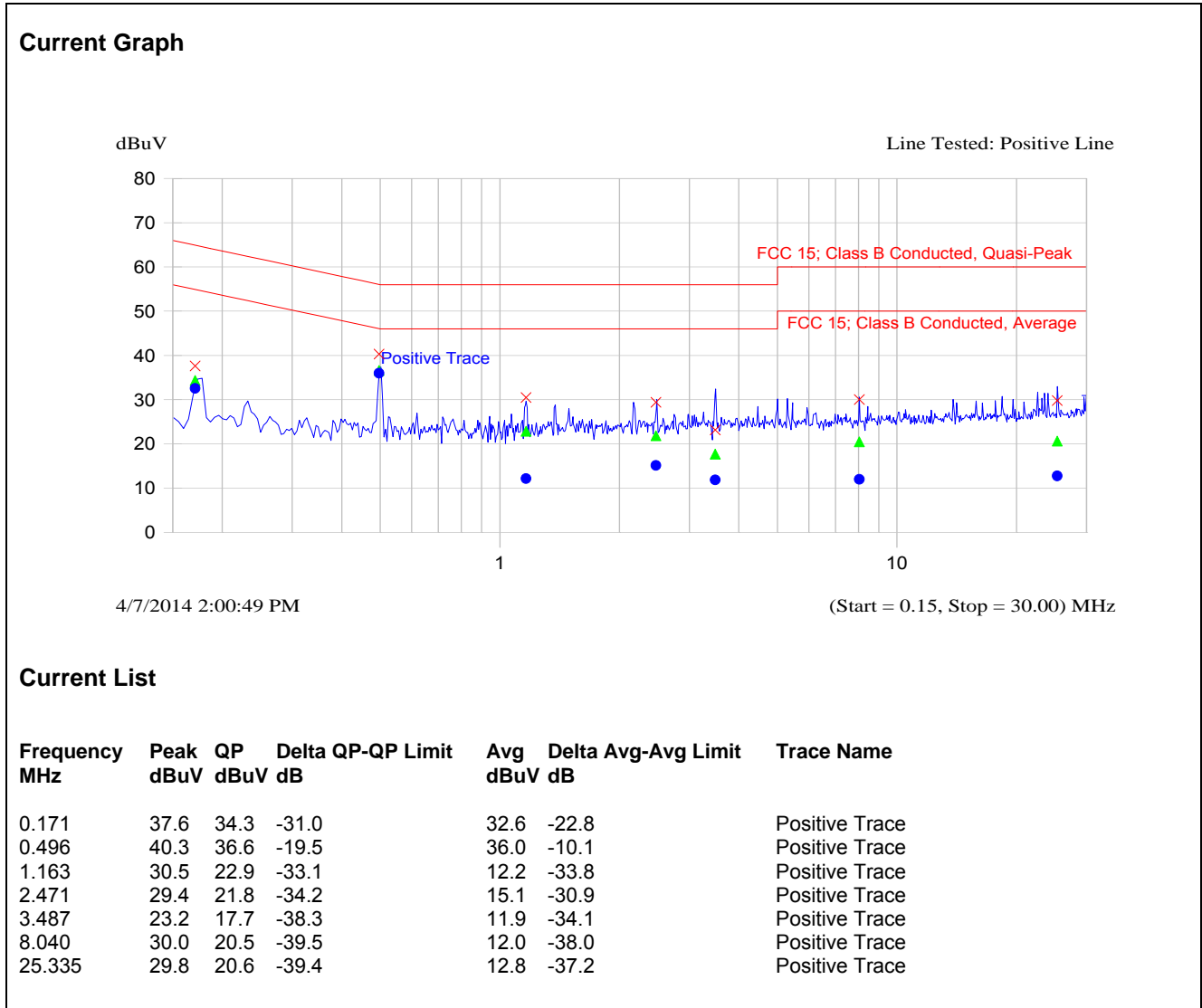

Plot 5.1.4.2. Power Line Conducted Emissions; Line Voltage: 12 V DC; Line Tested: Negative, Tx Mode

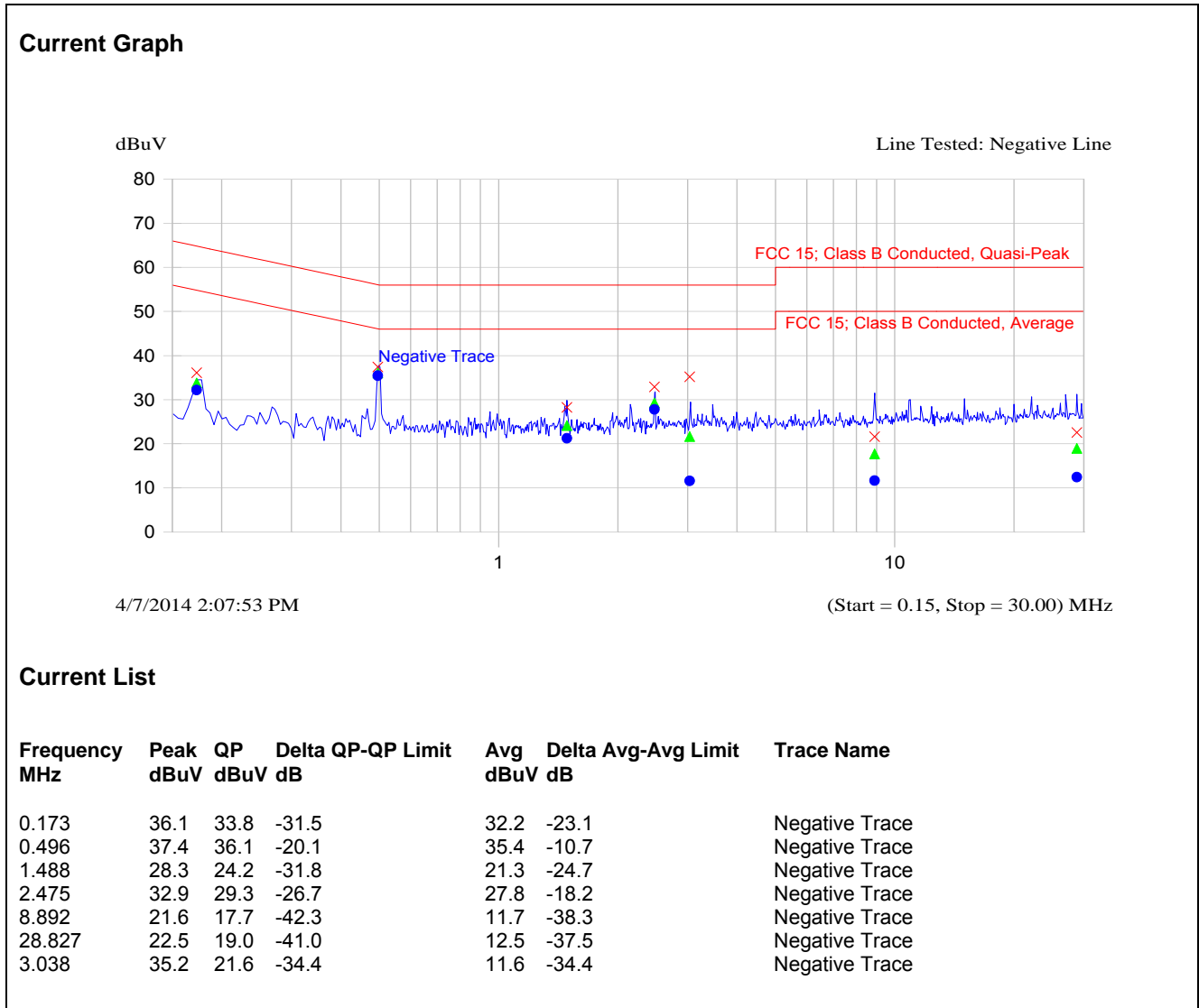

Plot 5.1.4.3. Power Line Conducted Emissions; Line Voltage: 24 V DC; Line Tested: Positive, Tx Mode

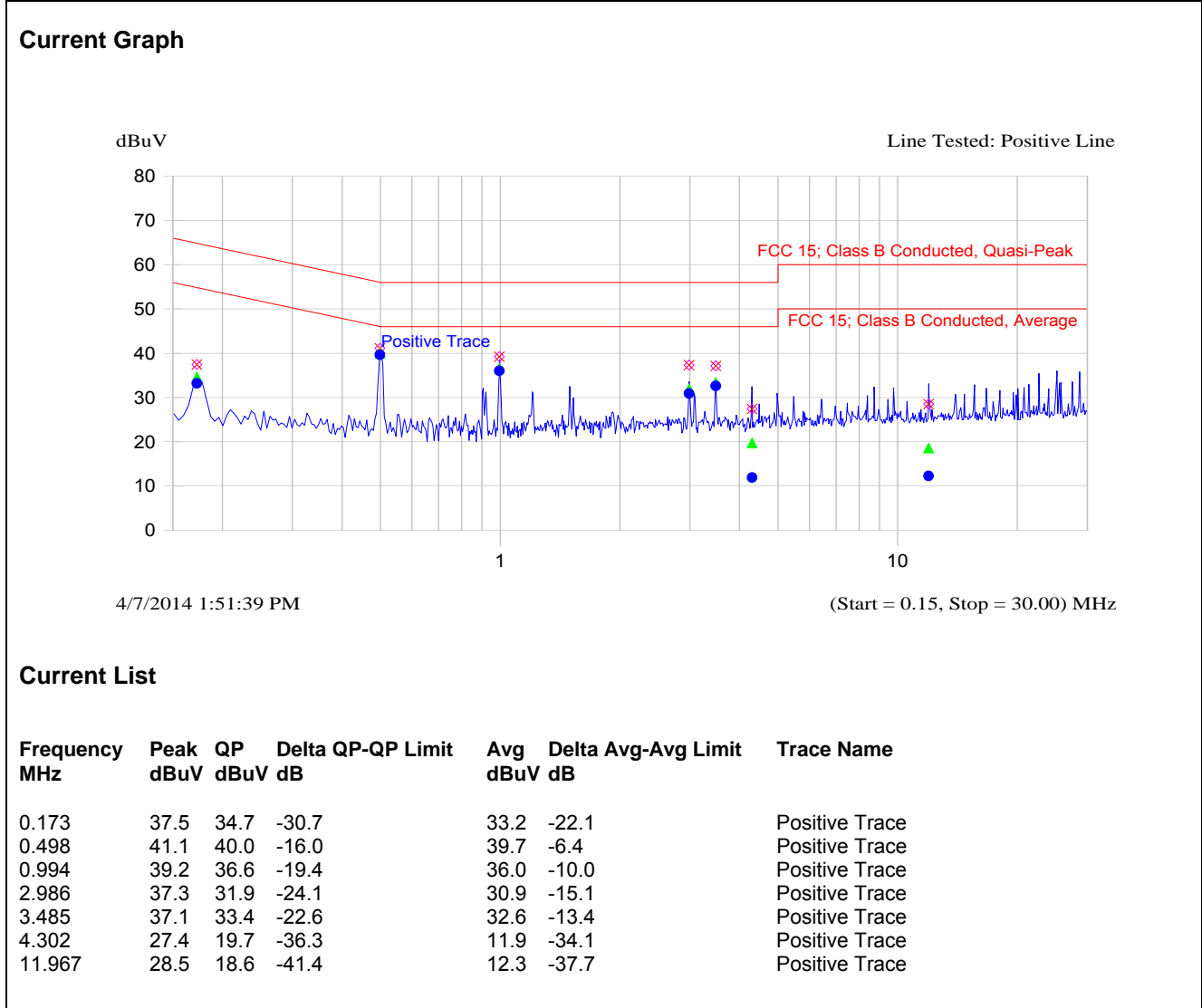

Plot 5.1.4.4. Power Line Conducted Emissions; Line Voltage: 24 V DC; Line Tested: Negative, Tx Mode

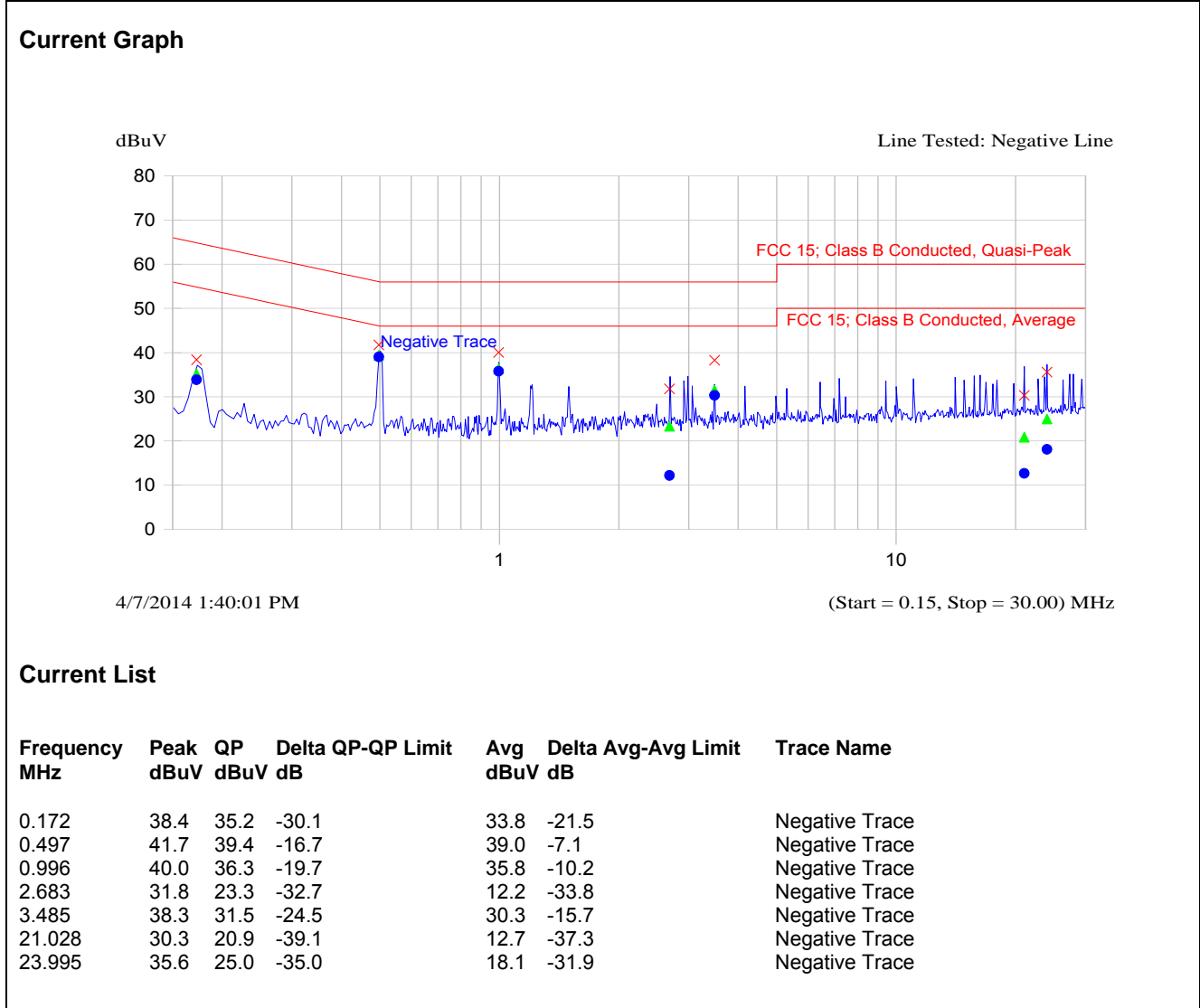

Plot 5.1.4.5. Power Line Conducted Emissions; Line Voltage: 12 V DC; Line Tested: Positive, Rx Mode

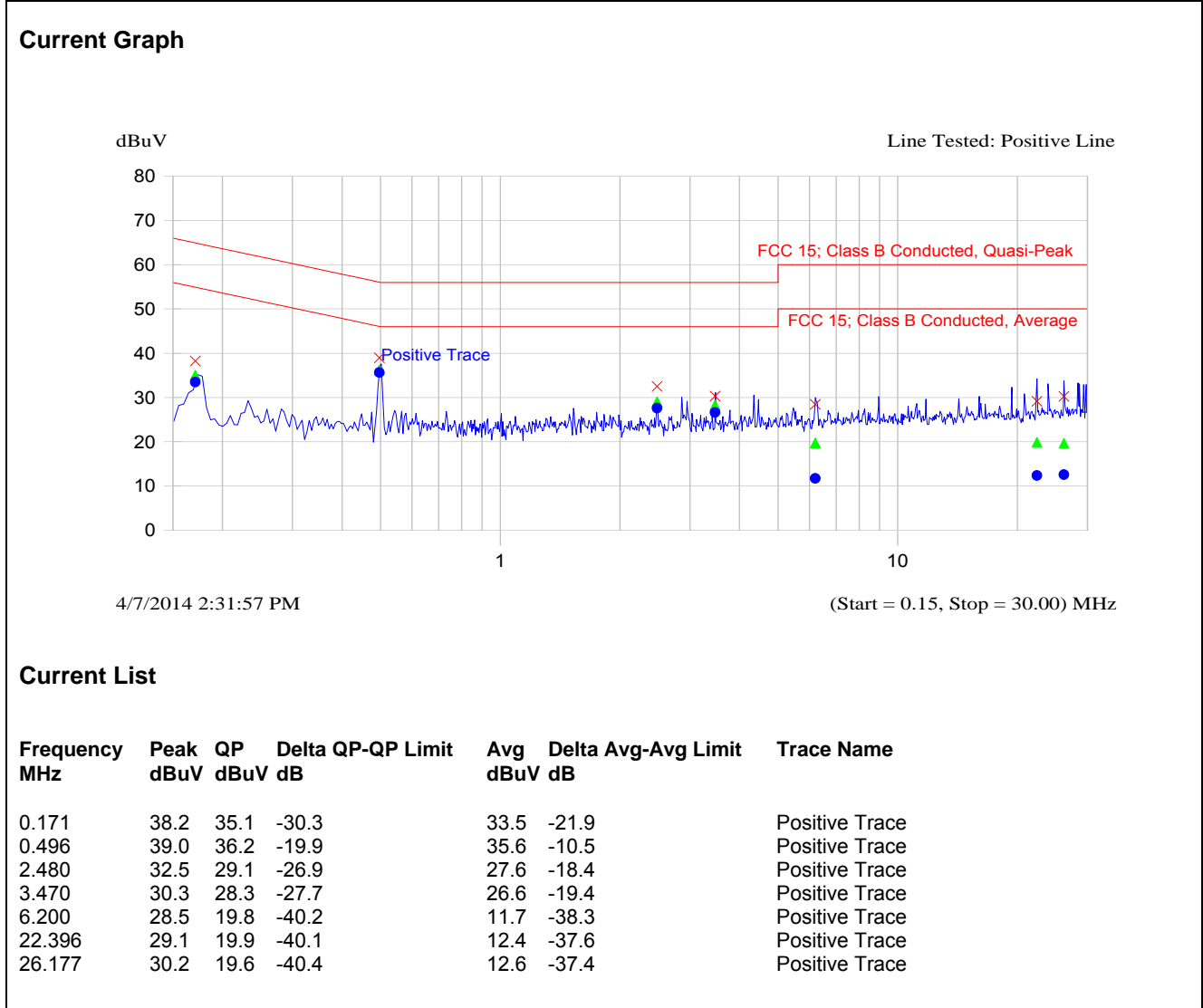

Plot 5.1.4.6. Power Line Conducted Emissions; Line Voltage: 12 V DC; Line Tested: Negative, Rx Mode

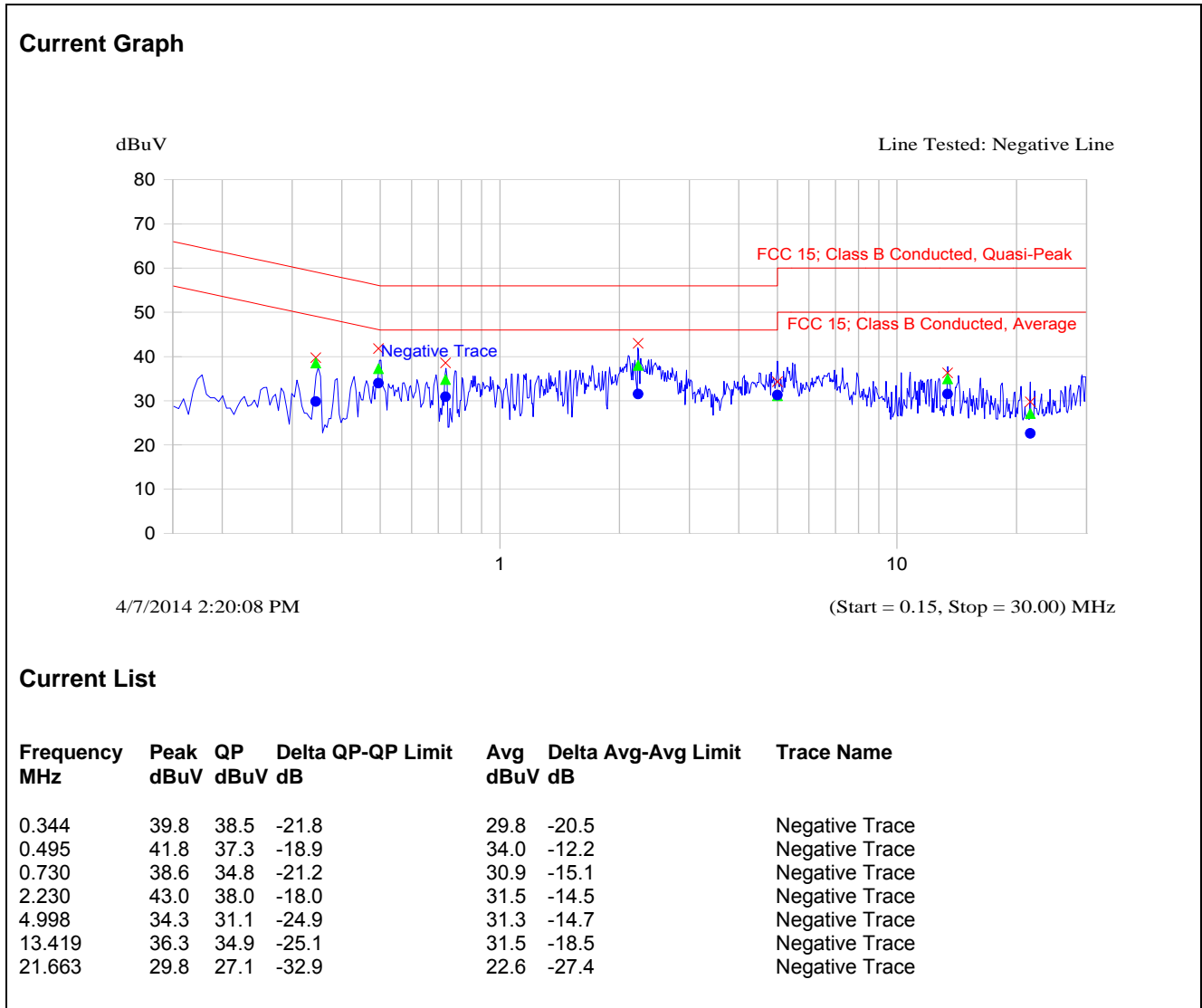

Plot 5.1.4.7. Power Line Conducted Emissions; Line Voltage: 24 V DC; Line Tested: Positive, Rx Mode

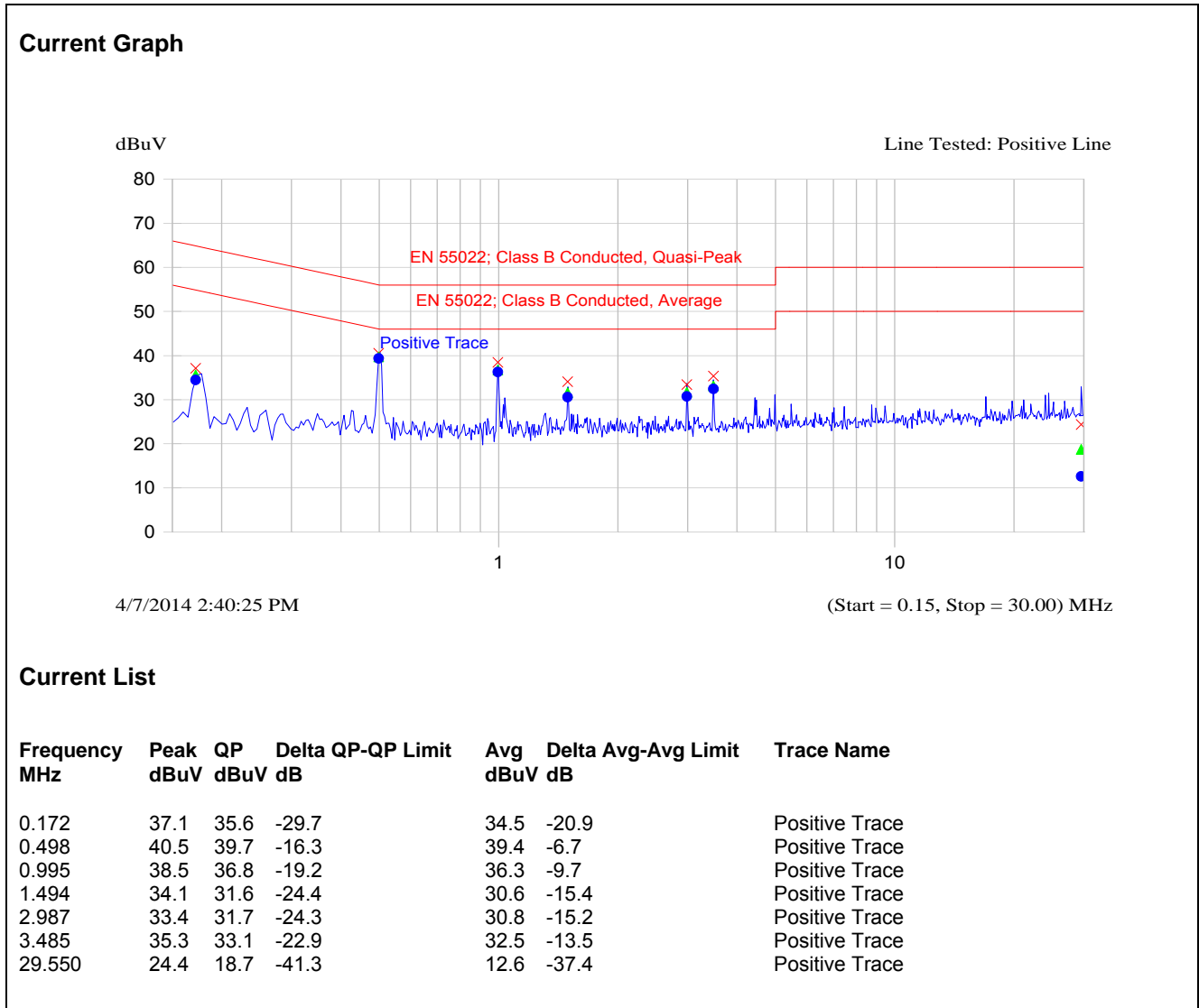

Plot 5.1.4.8. Power Line Conducted Emissions; Line Voltage: 24 V DC; Line Tested: Negative, Rx Mode

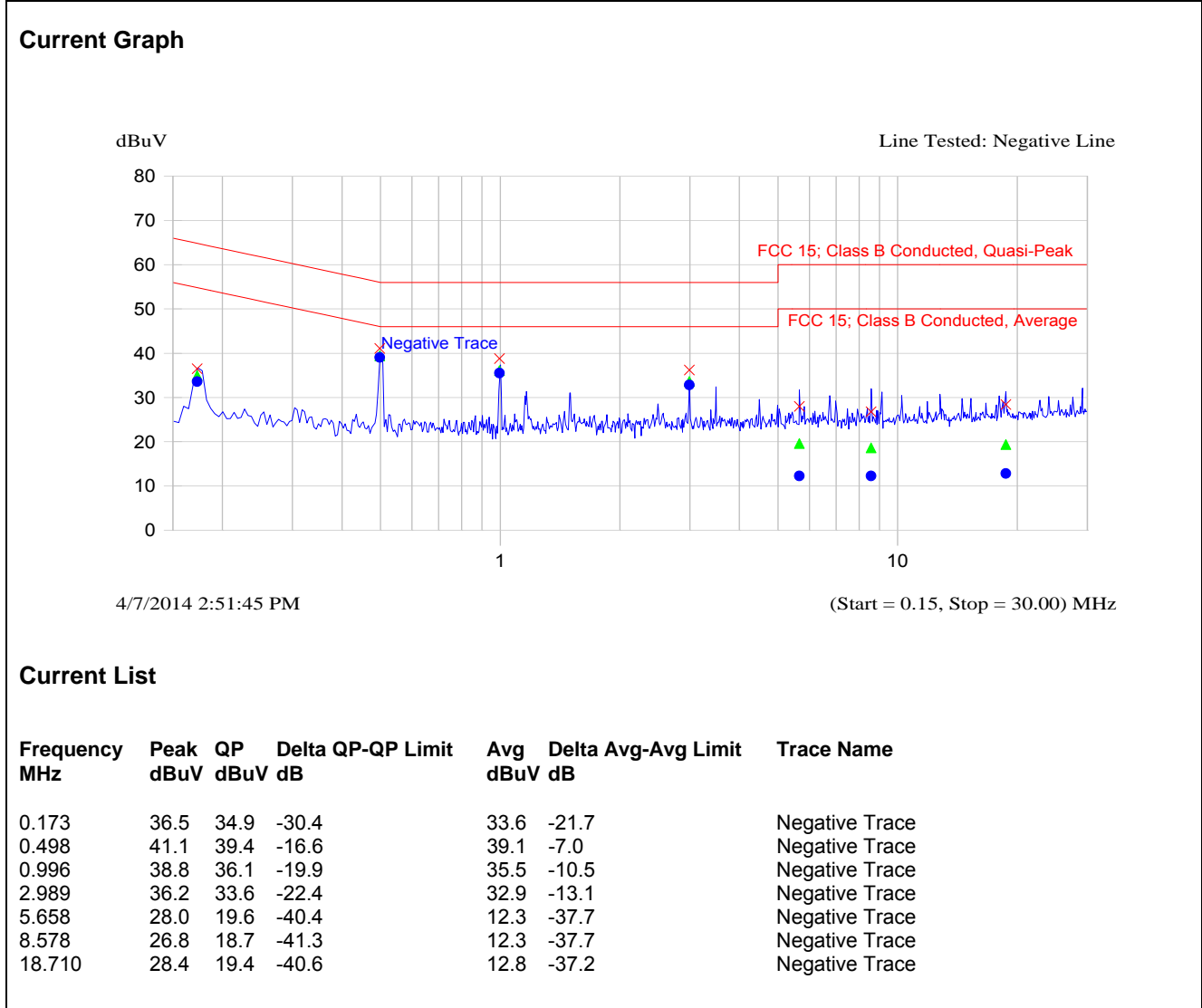

5.2. OCCUPIED BANDWIDTH [§ 15.247(a)(2)]

5.2.1. Limit(s)

The minimum 6 dB bandwidth shall be at least 500 kHz.

5.2.2. Method of Measurements

KDB Publication No. 558074 D01 DTS Meas Guidance V03r01, Section 8.1 Option 1

5.2.3. Test Arrangement

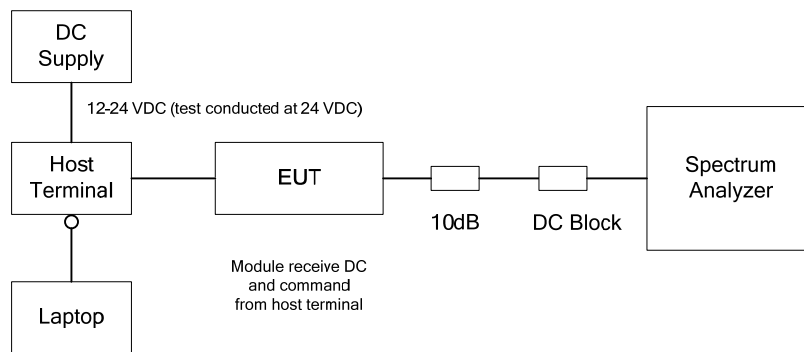

5.2.4. Test Data

802.11b Mode			
Operating Mode	Frequency (MHz)	6 dB Bandwidth (MHz)	99% Occupied Bandwidth (MHz)
1 Mbps DBPSK	2412	10.07	14.10
	2437	10.02	14.17
	2462	10.02	14.31
2 Mbps DQPSK	2412	9.77	14.59
	2437	9.87	14.31
	2462	9.72	14.31
11 Mbps CCK	2412	9.77	14.66
	2437	9.67	14.66
	2462	9.77	14.38

802.11g Mode			
Operating Mode	Frequency (MHz)	6 dB Bandwidth (MHz)	99% Occupied Bandwidth (MHz)
9 Mbps BPSK	2412	15.99	19.24
	2437	15.99	18.14
	2462	15.99	18.04
18 Mbps QPSK	2412	15.99	17.54
	2437	16.06	17.23
	2462	15.99	17.13
36 Mbps 16-QAM	2412	16.34	16.93
	2437	16.34	16.73
	2462	16.34	16.83
54 Mbps 64-QAM	2412	16.48	16.83
	2437	16.48	16.83
	2462	16.41	16.73

802.11n 800ns Mode			
Operating Mode	Frequency (MHz)	6 dB Bandwidth (MHz)	99% Occupied Bandwidth (MHz)
6.5 Mbps BPSK1/2	2412	16.55	19.14
	2437	16.62	19.14
	2462	16.41	19.14
19.5 Mbps QPSK 3/4	2412	16.76	18.44
	2437	16.62	18.44
	2462	16.62	18.14
39 Mbps 16-QAM 3/4	2412	17.04	17.94
	2437	17.11	17.94
	2462	17.04	17.94
65 Mbps 64-QAM 5/6	2412	16.90	17.94
	2437	17.04	17.94
	2462	16.97	17.94

See the following plots for detailed measurements.

Plot 5.2.4.1. 6 dB Bandwidth, 802.11b, 1 Mbps DBPSK, 2412 MHz

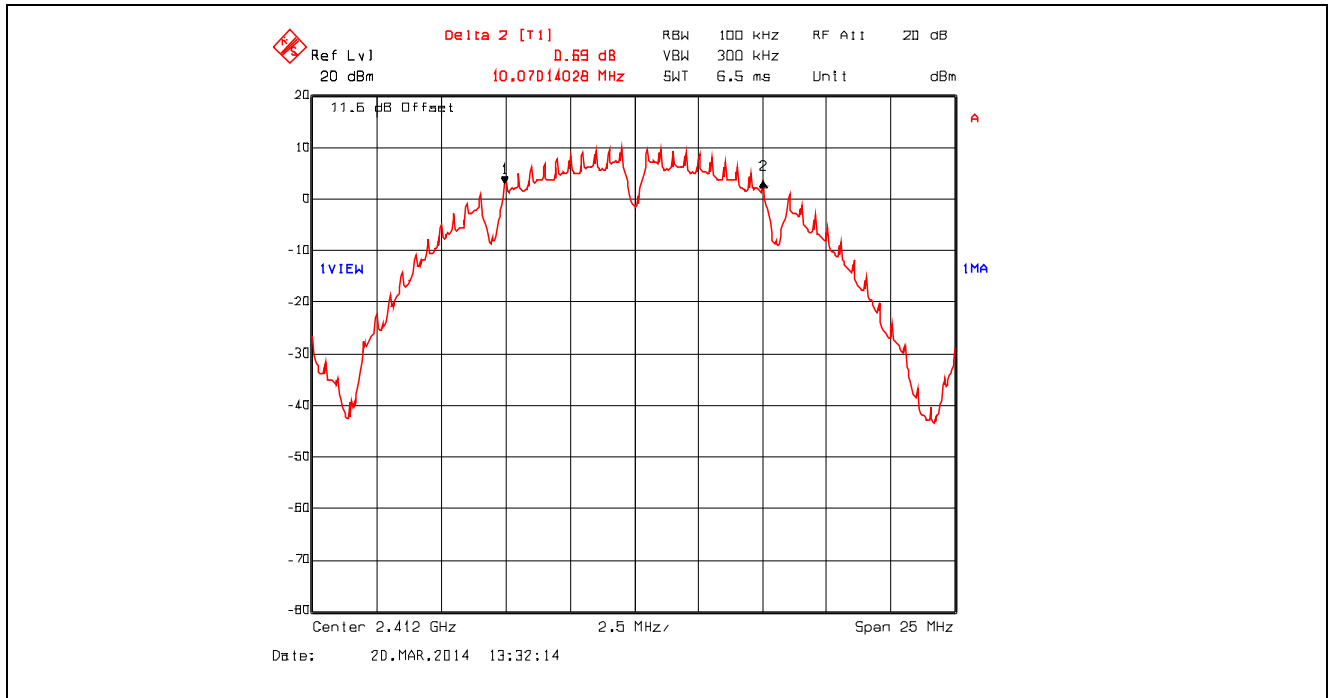

Plot 5.2.4.2. 6 dB Bandwidth, 802.11b, 1 Mbps DBPSK, 2437 MHz

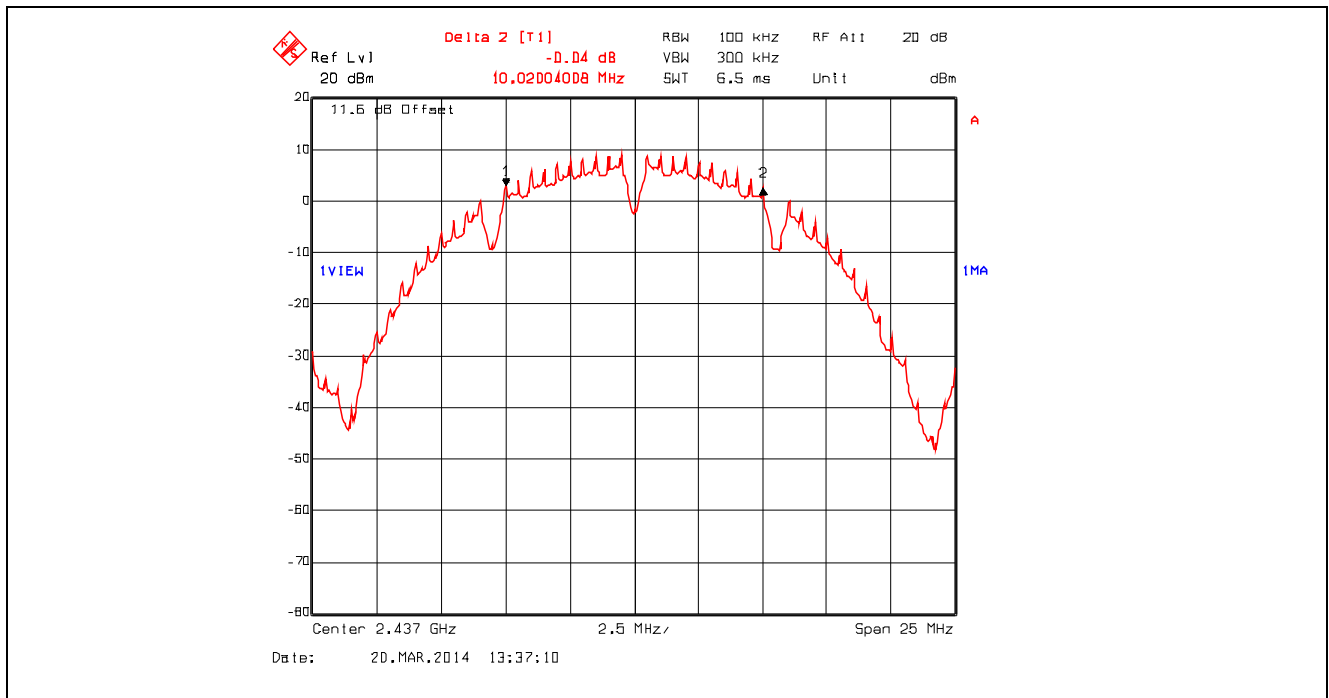

Plot 5.2.4.3. 6 dB Bandwidth, 802.11b, 1 Mbps DBPSK, 2462 MHz

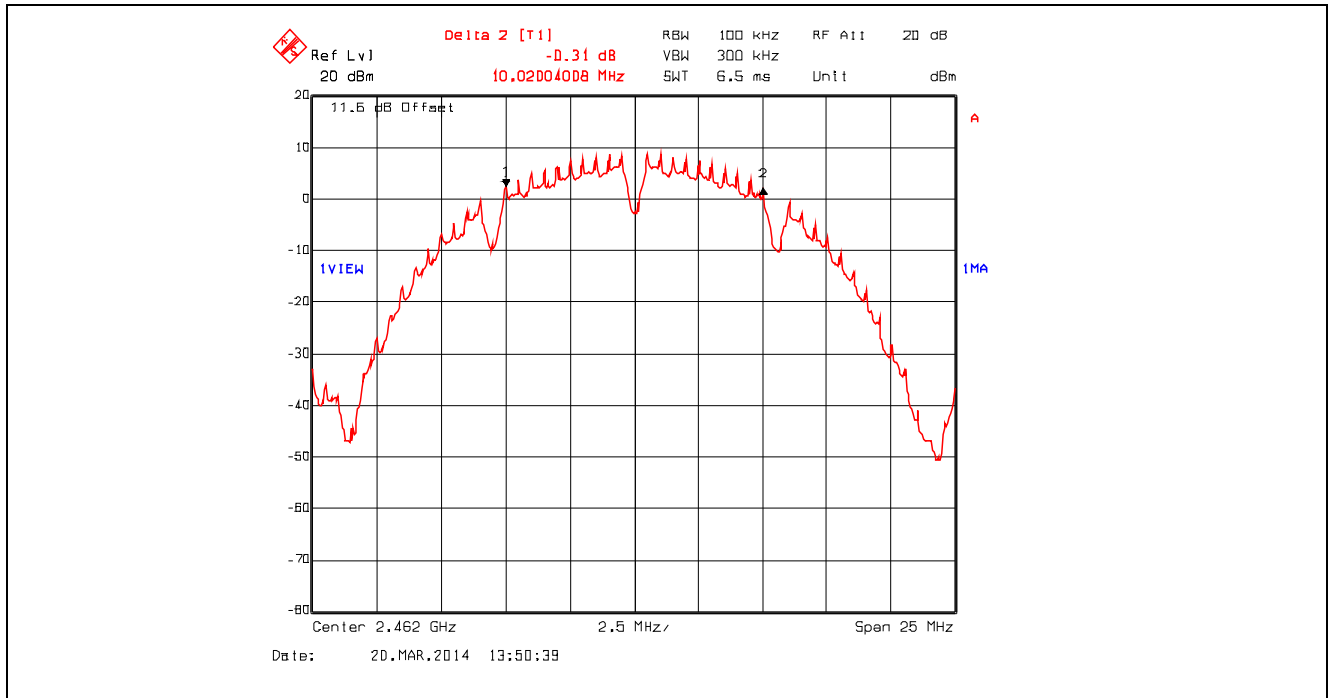

Plot 5.2.4.4. 6 dB Bandwidth, 802.11b, 2 Mbps DQPSK, 2412 MHz

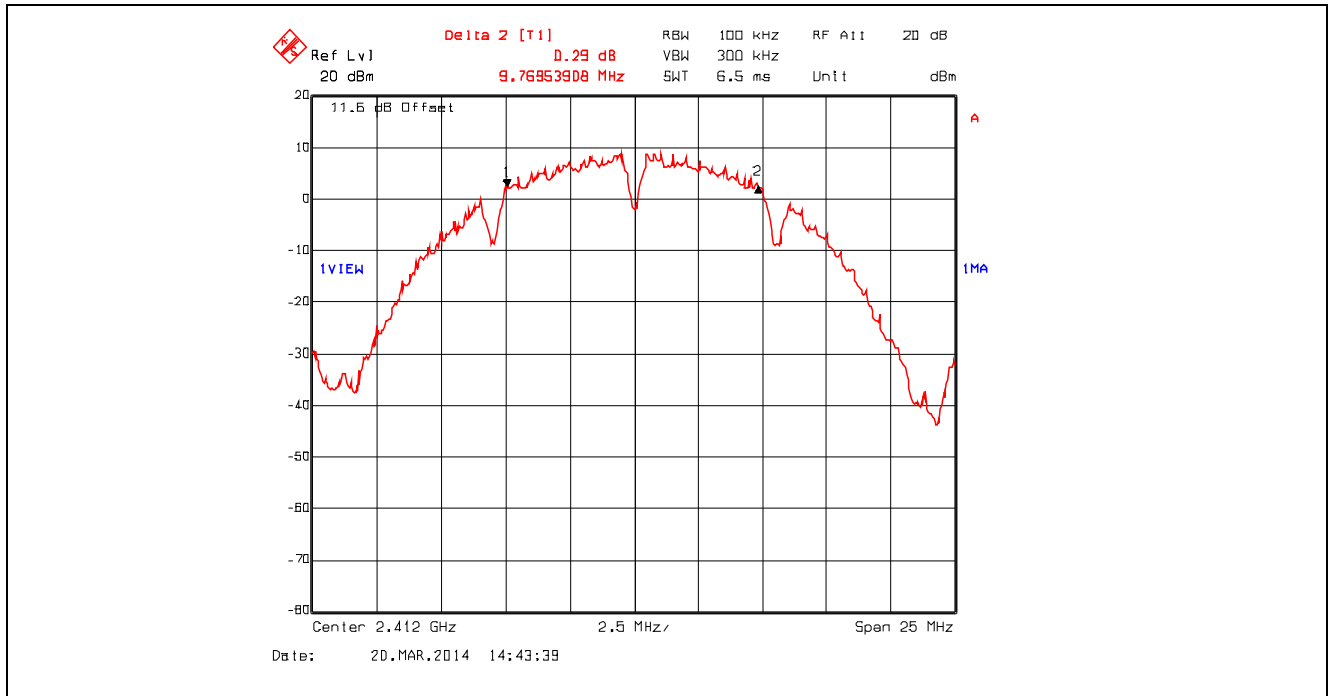

Plot 5.2.4.5. 6 dB Bandwidth, 802.11b, 2 Mbps DQPSK, 2437 MHz

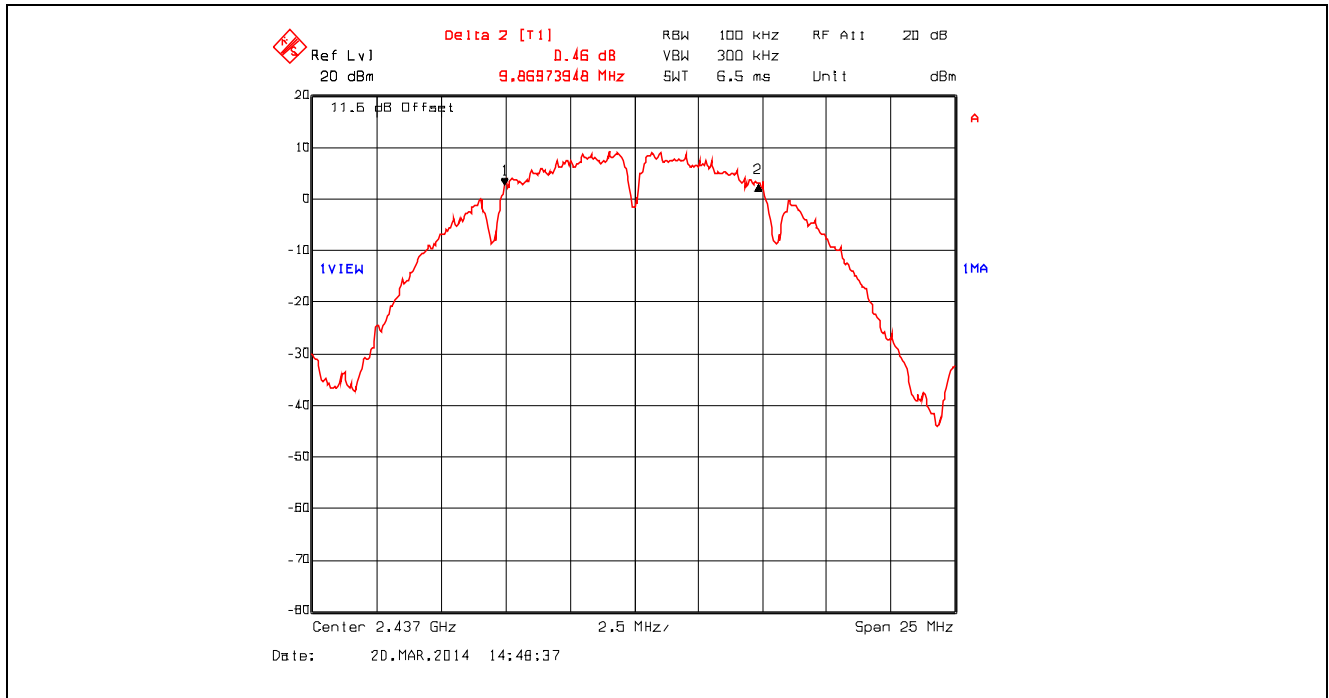

Plot 5.2.4.6. 6 dB Bandwidth, 802.11b, 2 Mbps DQPSK, 2462 MHz

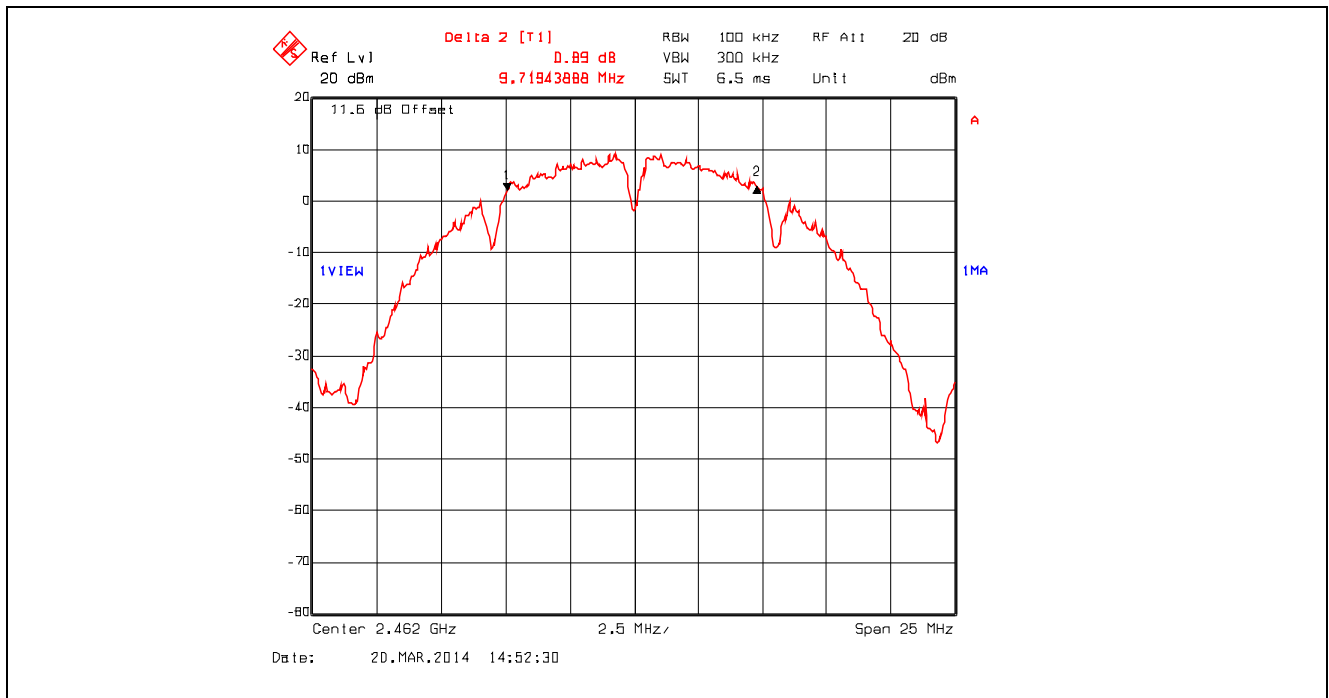

Plot 5.2.4.7. 6 dB Bandwidth, 802.11b, 11 Mbps CCK, 2412 MHz

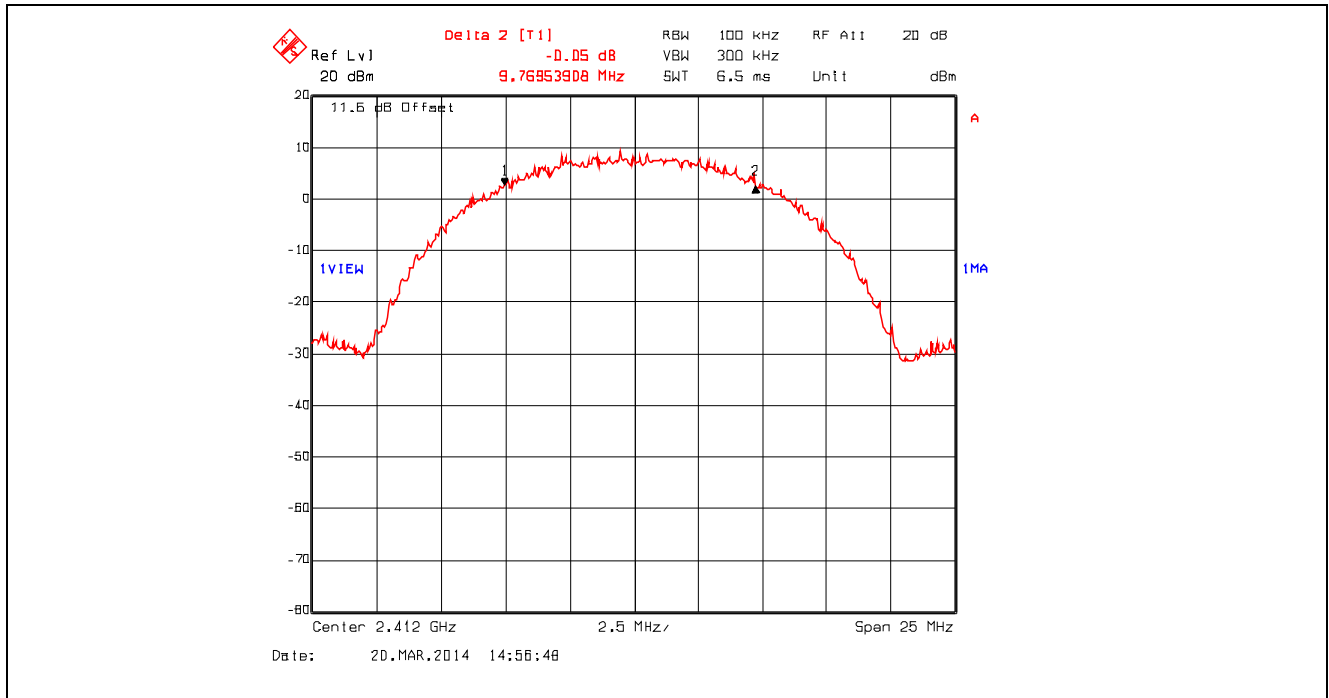

Plot 5.2.4.8. 6 dB Bandwidth, 802.11b, 11 Mbps CCK, 2437 MHz

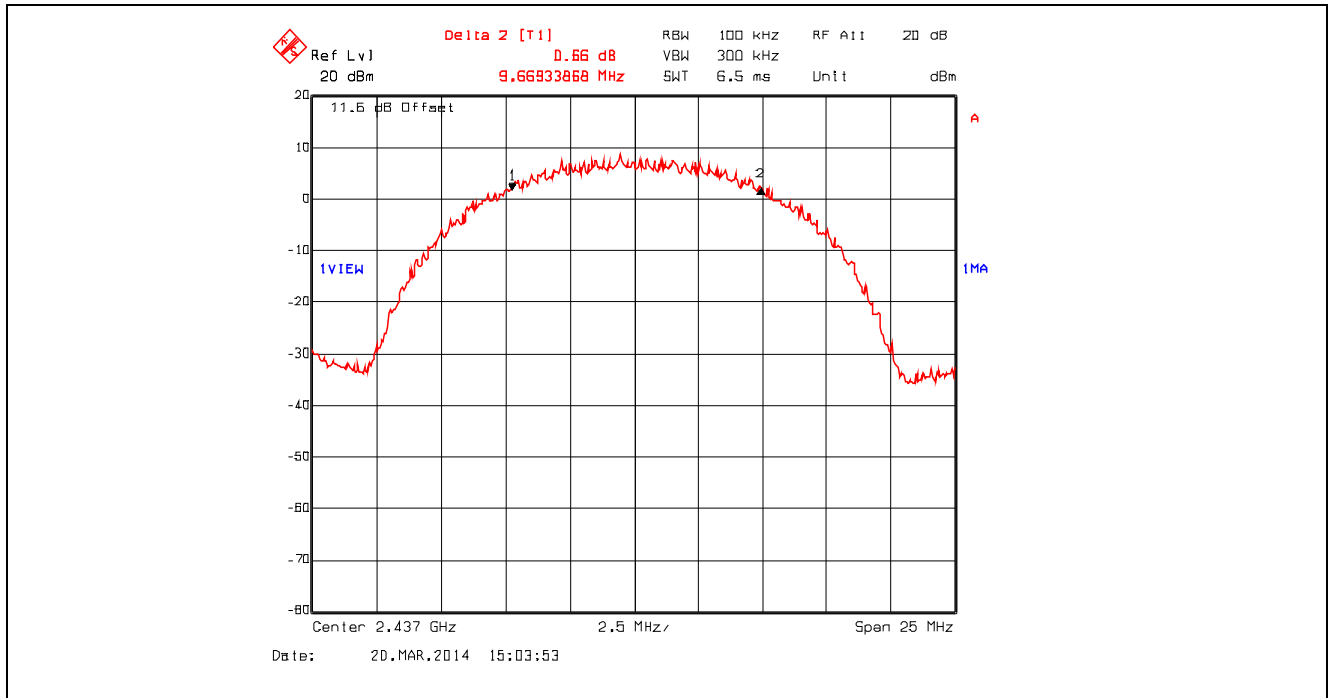

Plot 5.2.4.9. 6 dB Bandwidth, 802.11b, 11 Mbps CCK, 2462 MHz

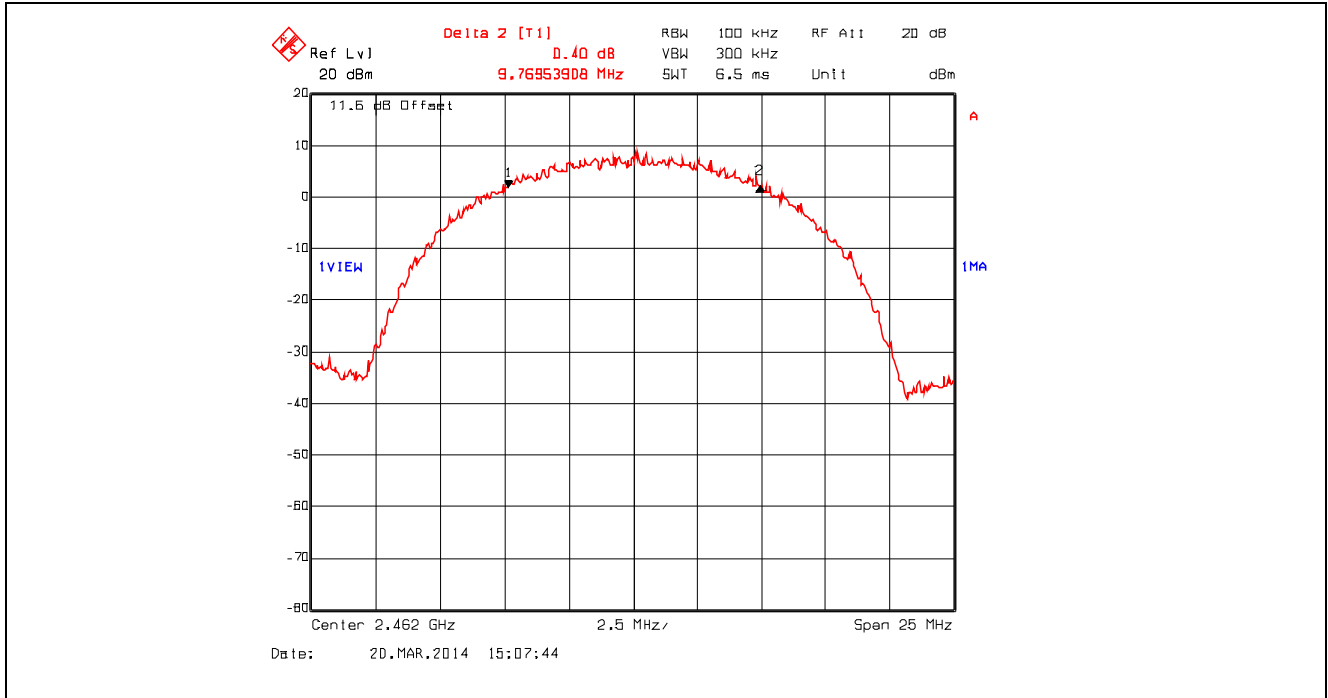

Plot 5.2.4.10. 6 dB Bandwidth, 802.11g, 9 Mbps BPSK, 2412 MHz

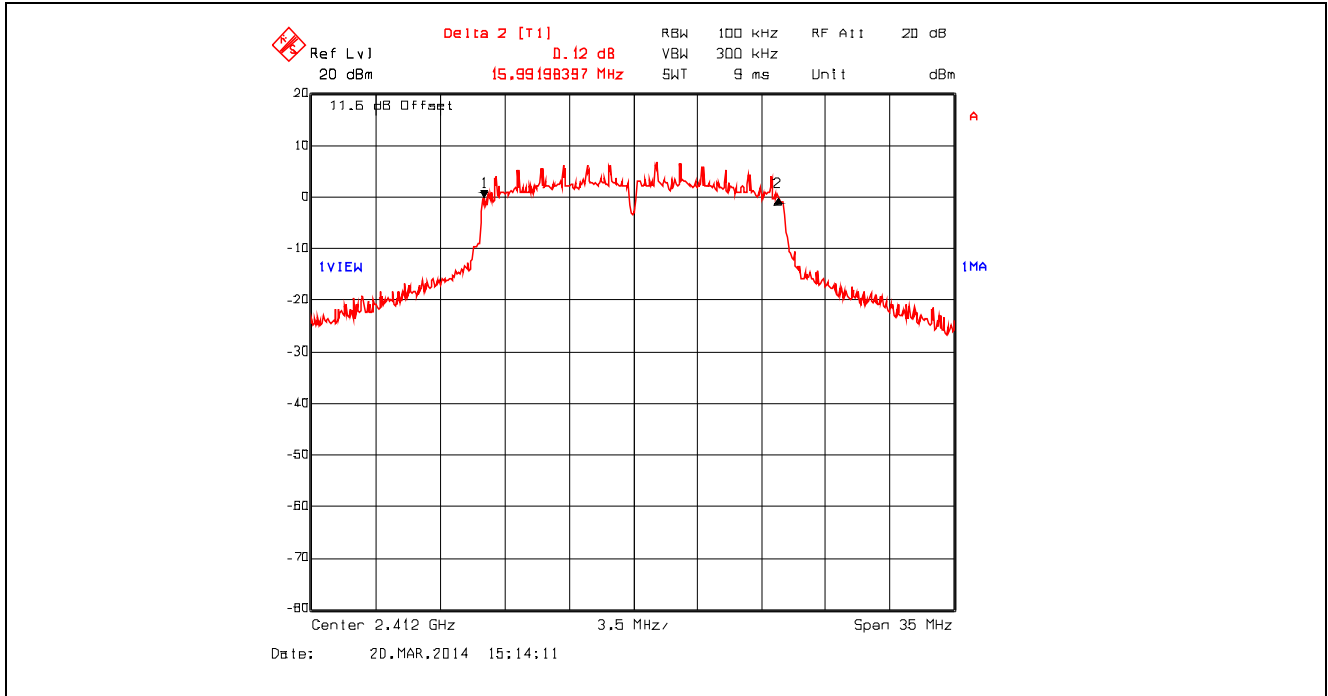

Plot 5.2.4.11. 6 dB Bandwidth, 802.11g, 9 Mbps BPSK, 2437 MHz

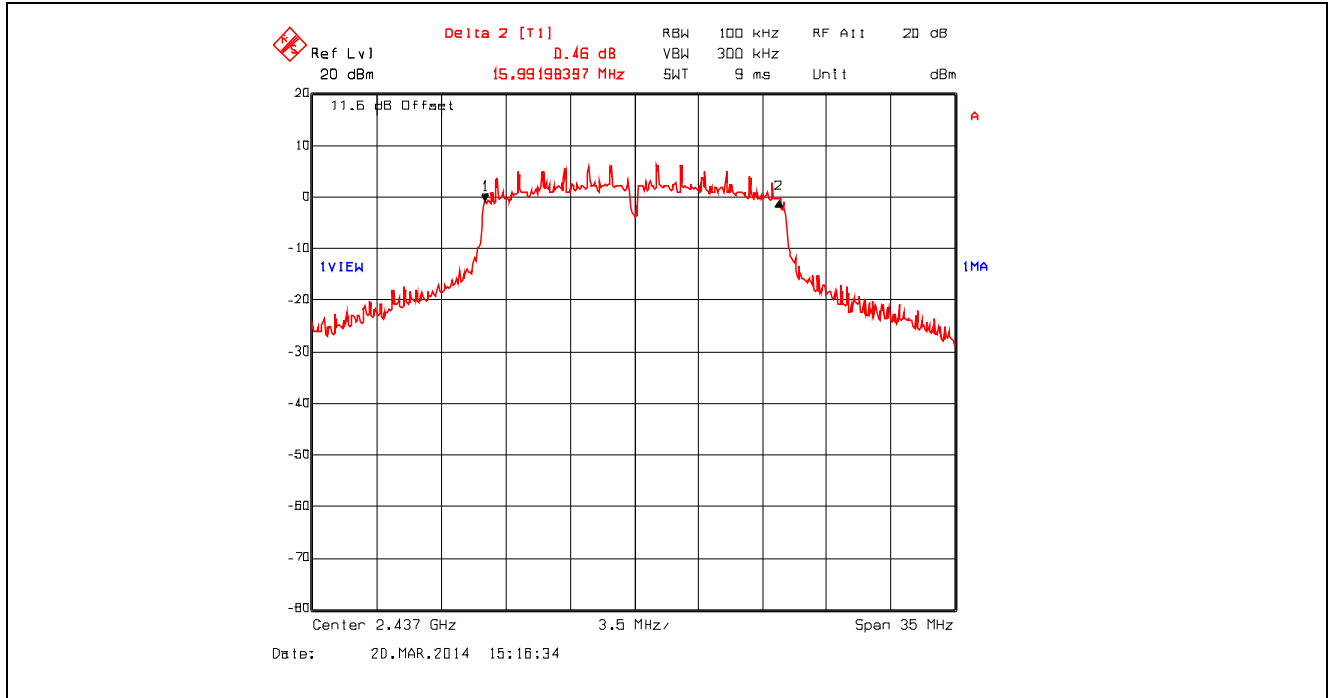

Plot 5.2.4.12. 6 dB Bandwidth, 802.11g, 9 Mbps BPSK, 2462 MHz

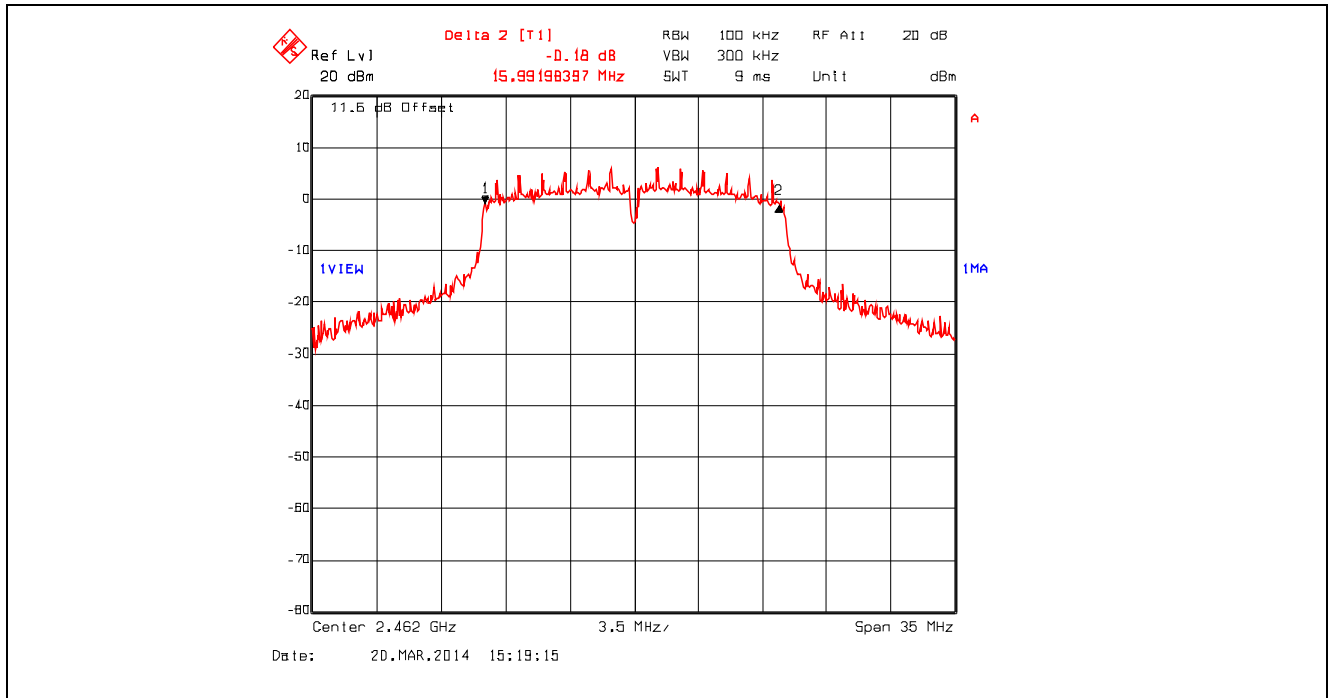

Plot 5.2.4.13. 6 dB Bandwidth, 802.11g, 18 Mbps QPSK, 2412 MHz

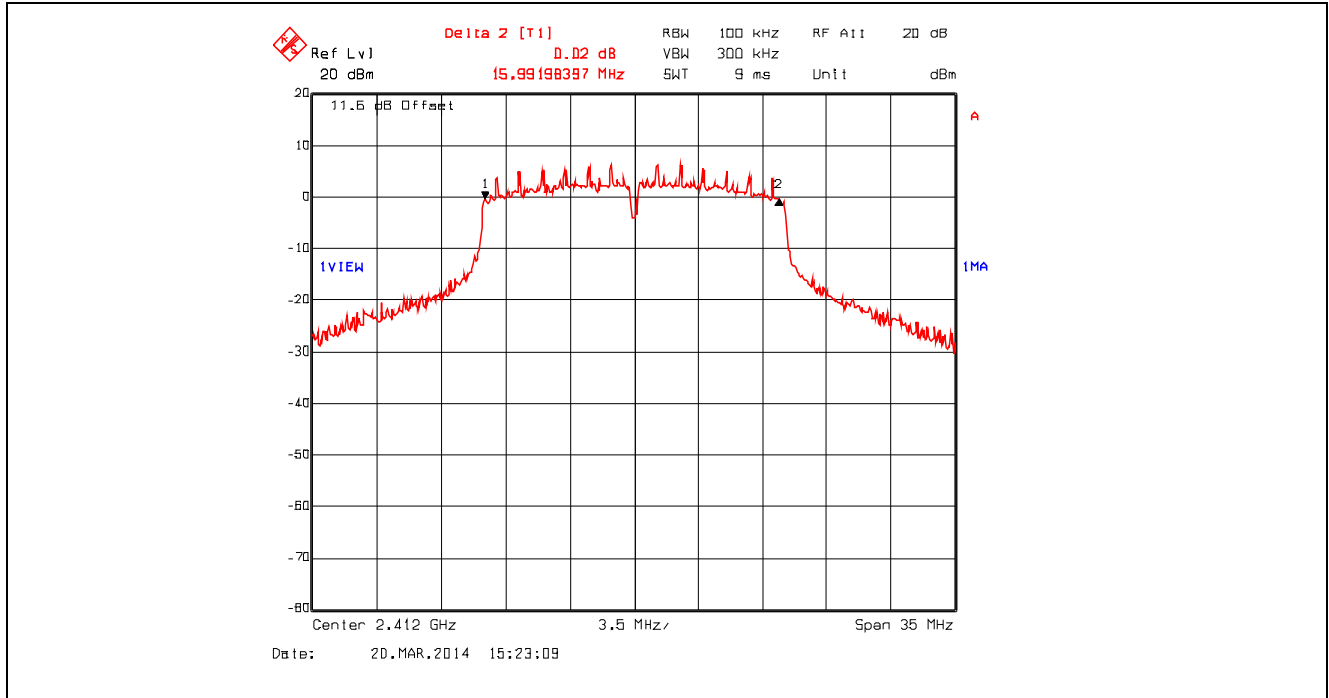

Plot 5.2.4.14. 6 dB Bandwidth, 802.11g, 18 Mbps QPSK, 2437 MHz

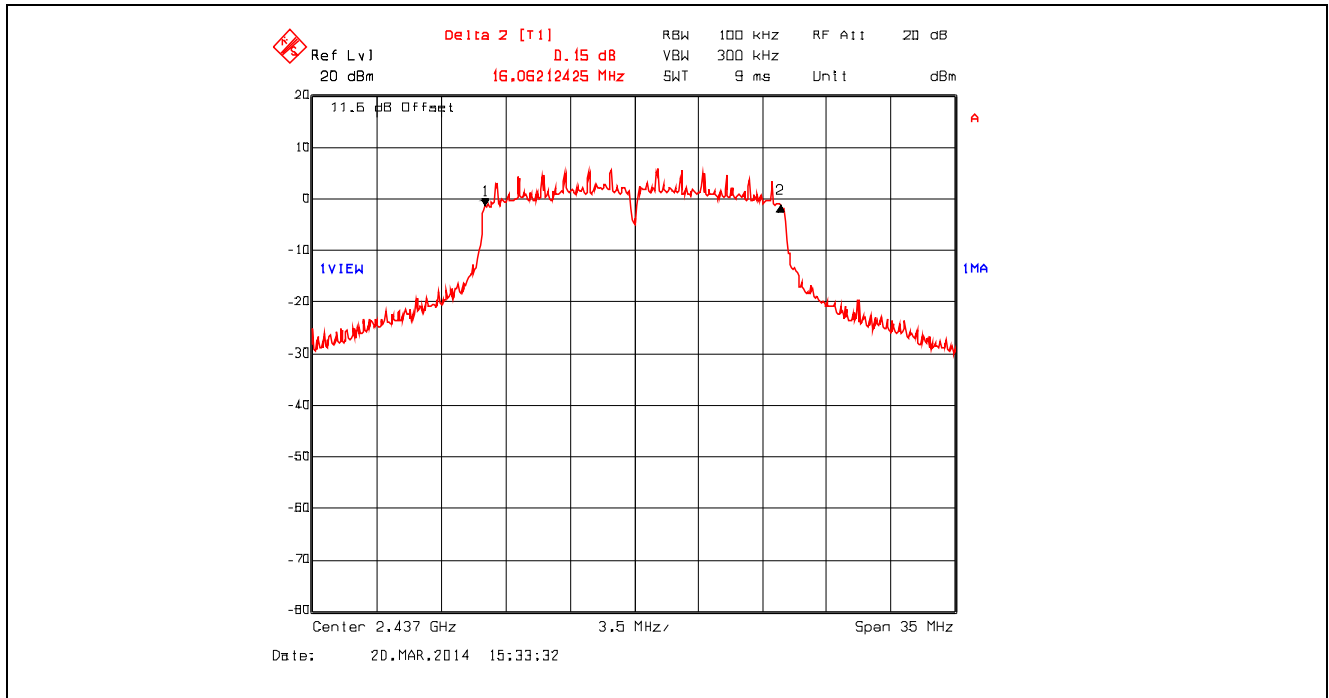

Plot 5.2.4.15. 6 dB Bandwidth, 802.11g, 18 Mbps QPSK, 2462 MHz

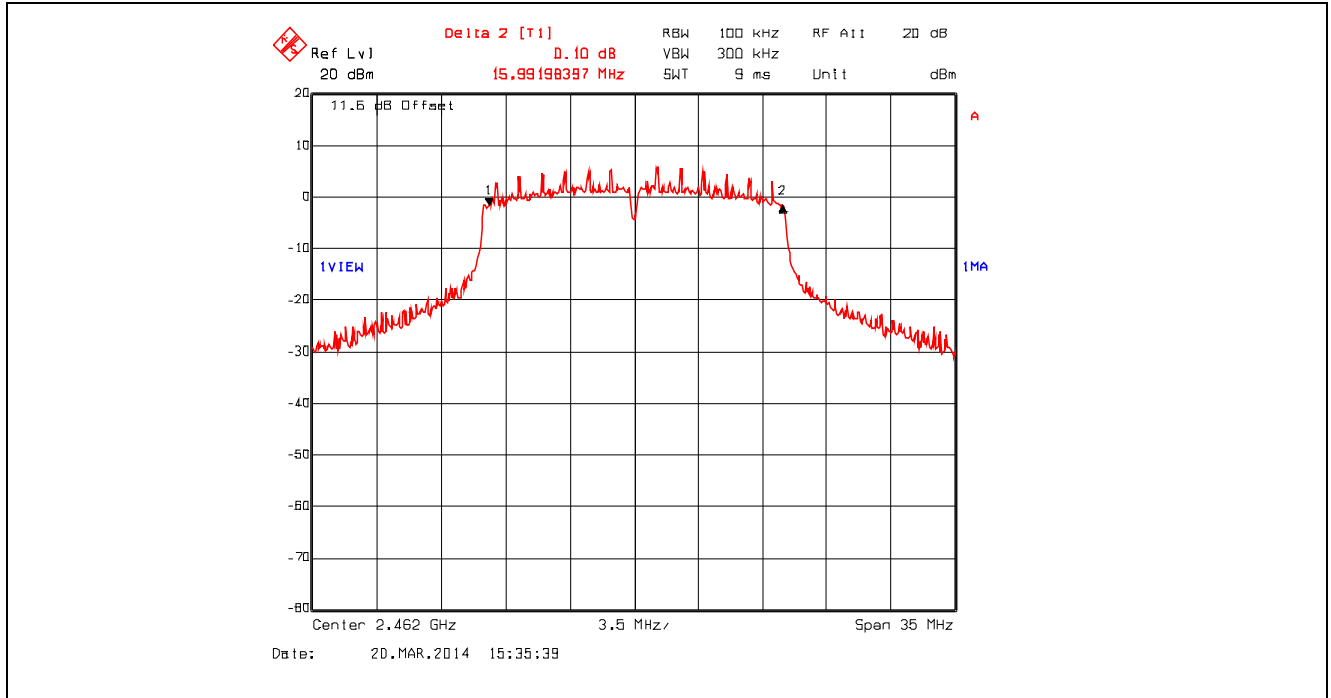

Plot 5.2.4.16. 6 dB Bandwidth, 802.11g, 36 Mbps 16-QAM, 2412 MHz

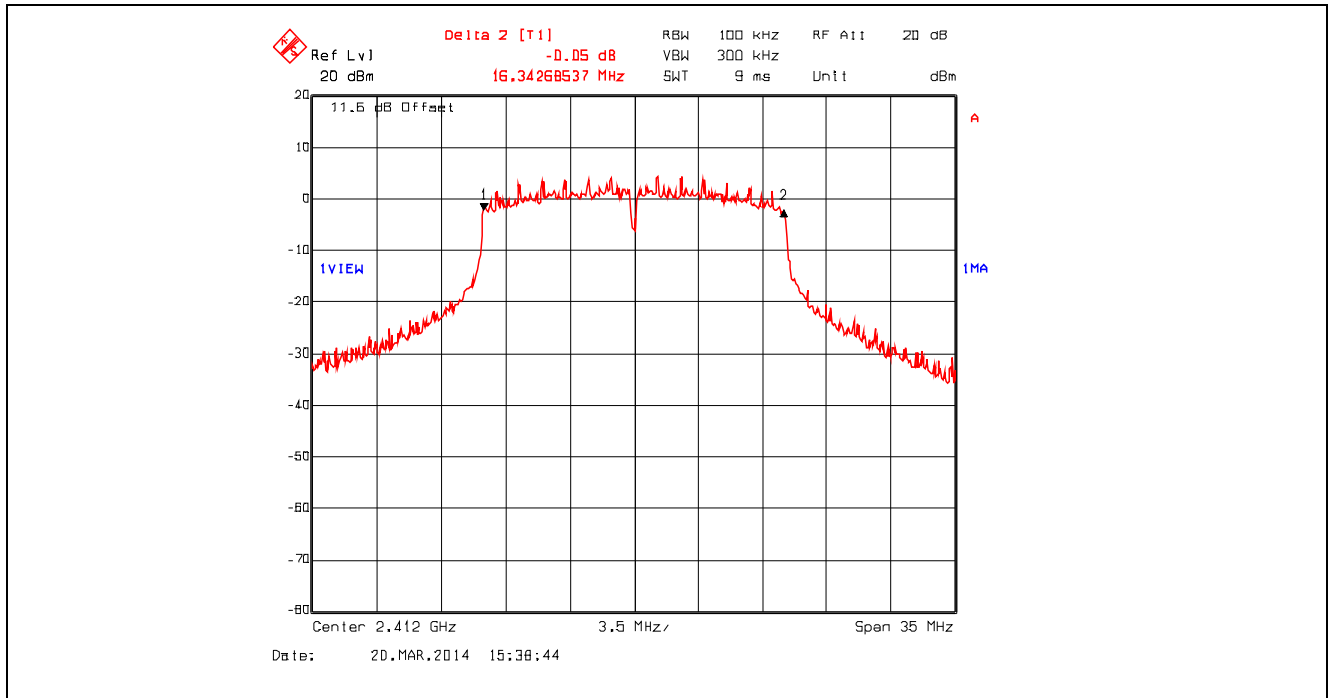

Plot 5.2.4.17. 6 dB Bandwidth, 802.11g, 36 Mbps 16-QAM, 2437 MHz

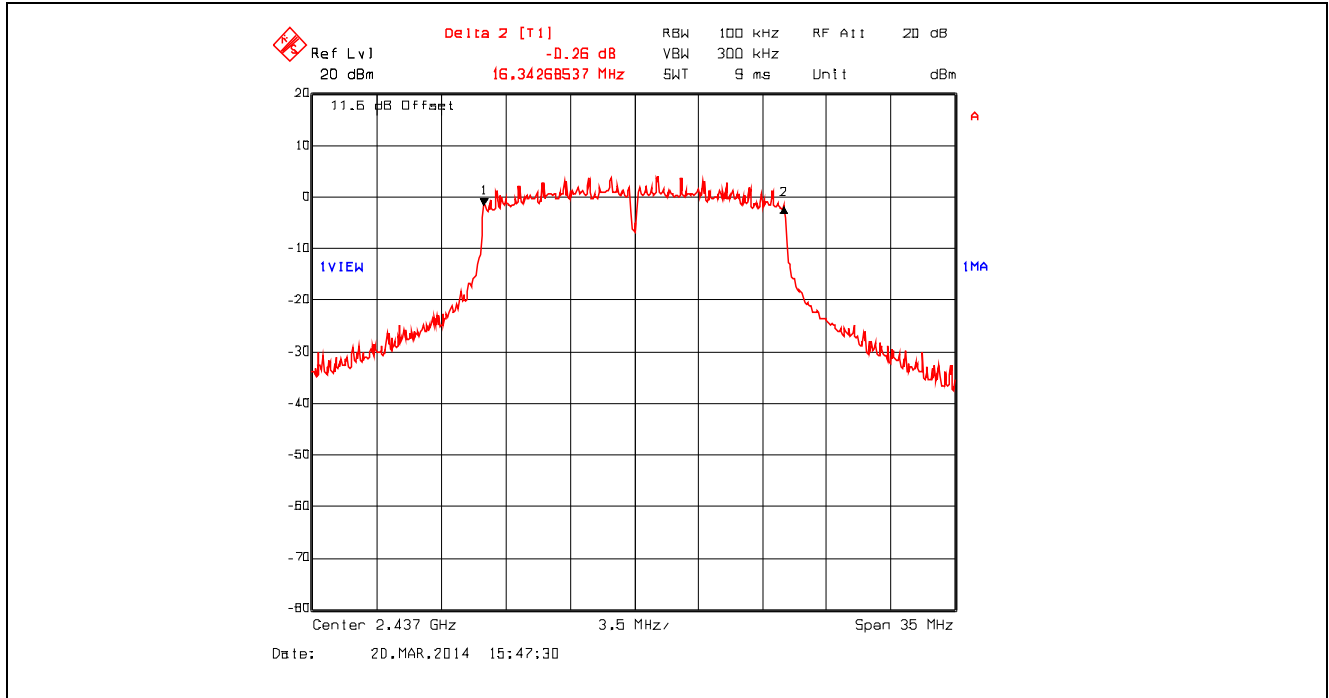

Plot 5.2.4.18. 6 dB Bandwidth, 802.11g, 36 Mbps 16-QAM, 2462 MHz

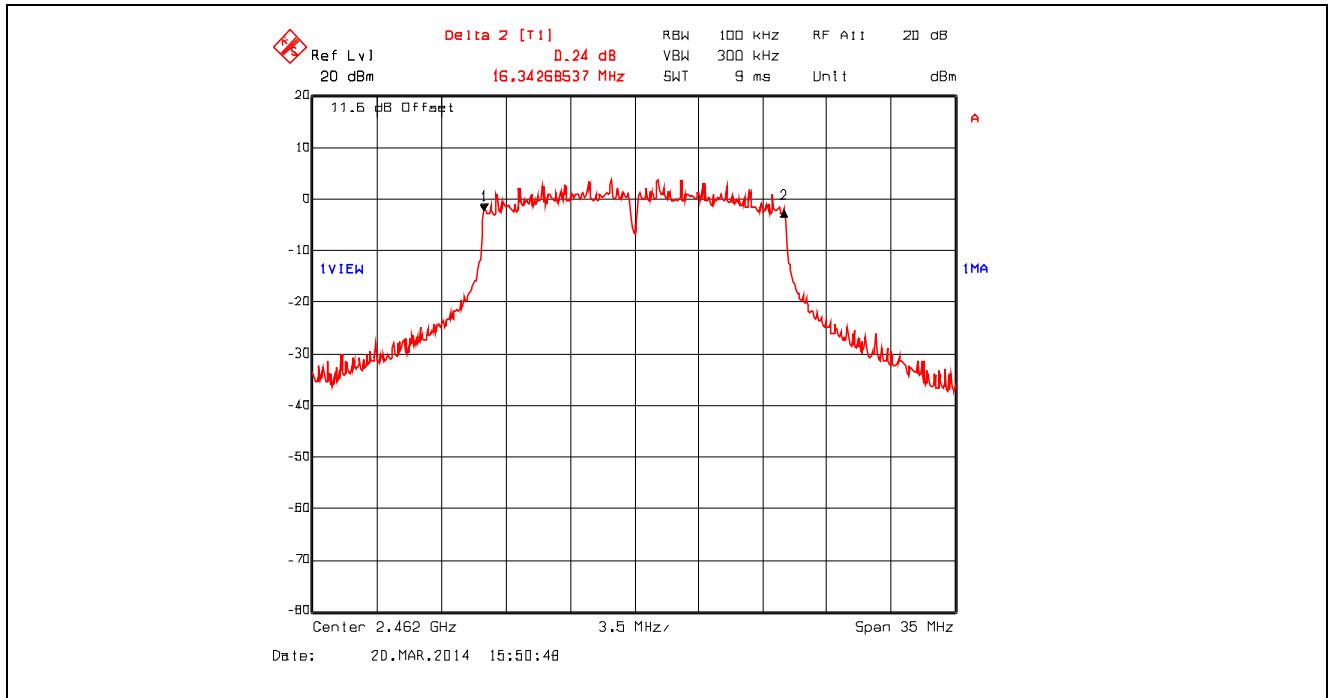

Plot 5.2.4.19. 6 dB Bandwidth, 802.11g, 54 Mbps 64-QAM, 2412 MHz

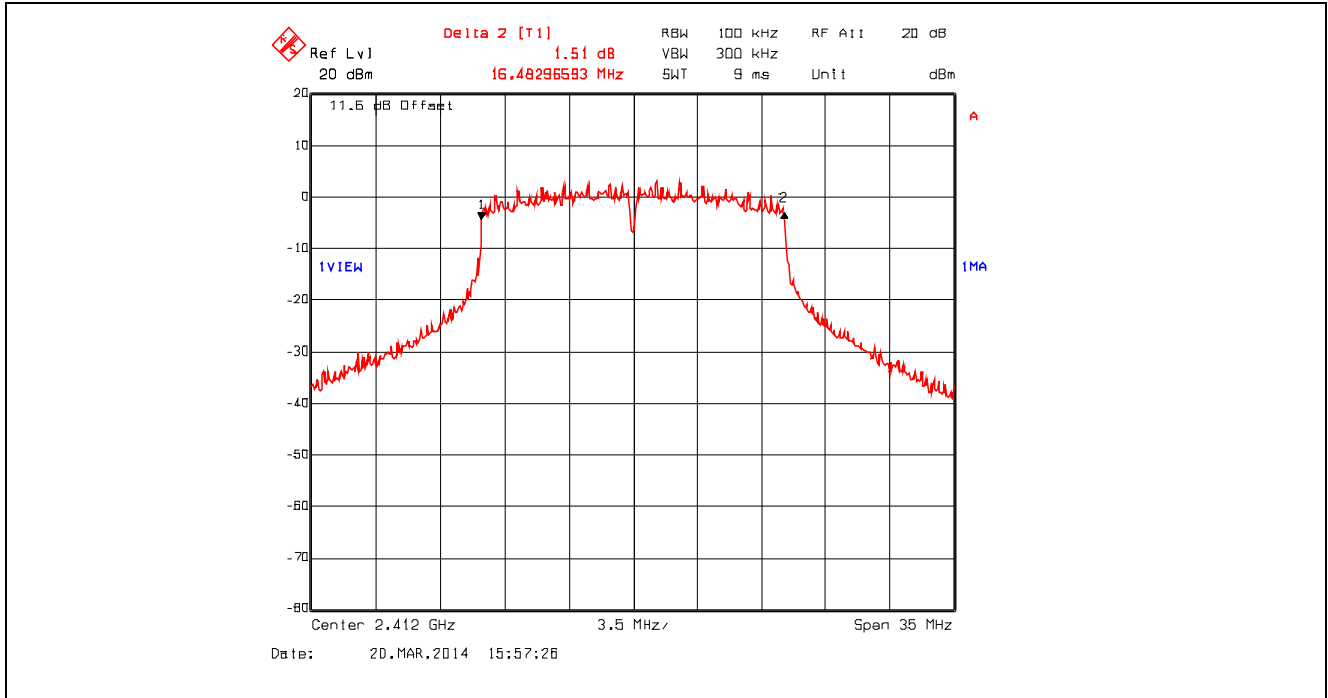

Plot 5.2.4.20. 6 dB Bandwidth, 802.11g, 54 Mbps 64-QAM, 2437 MHz

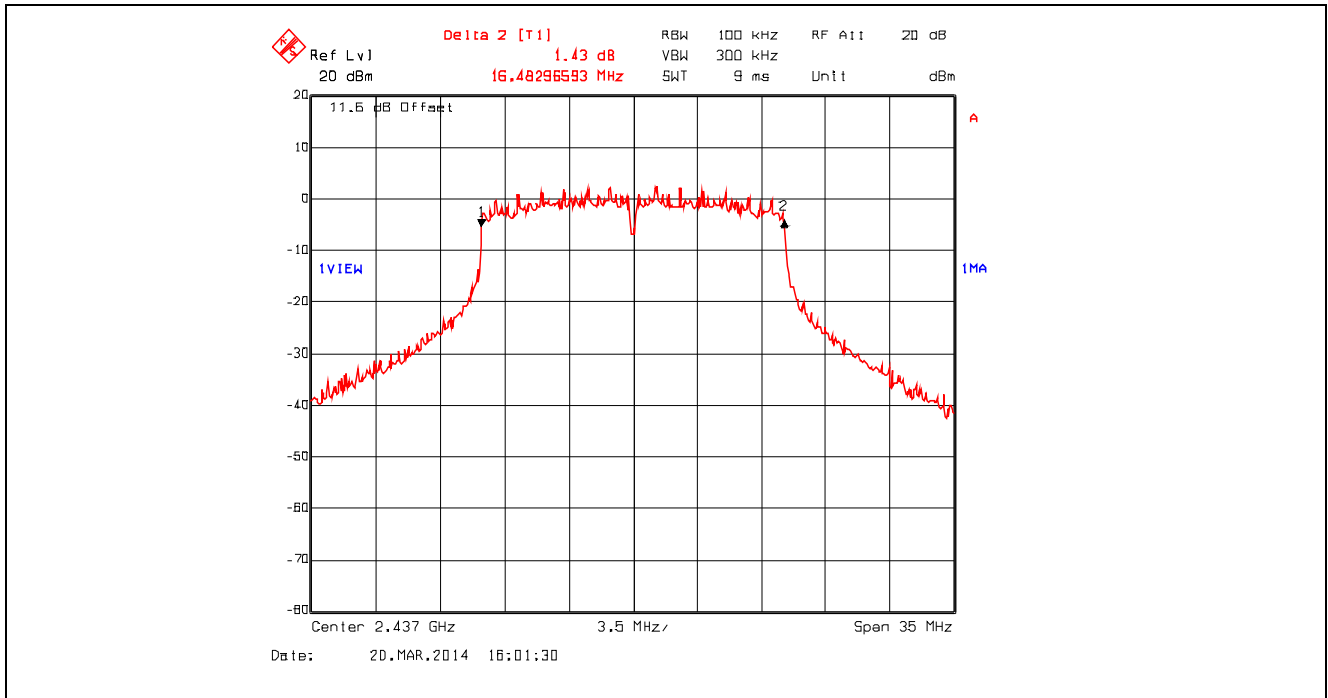

Plot 5.2.4.21. 6 dB Bandwidth, 802.11g, 54 Mbps 64-QAM, 2462 MHz

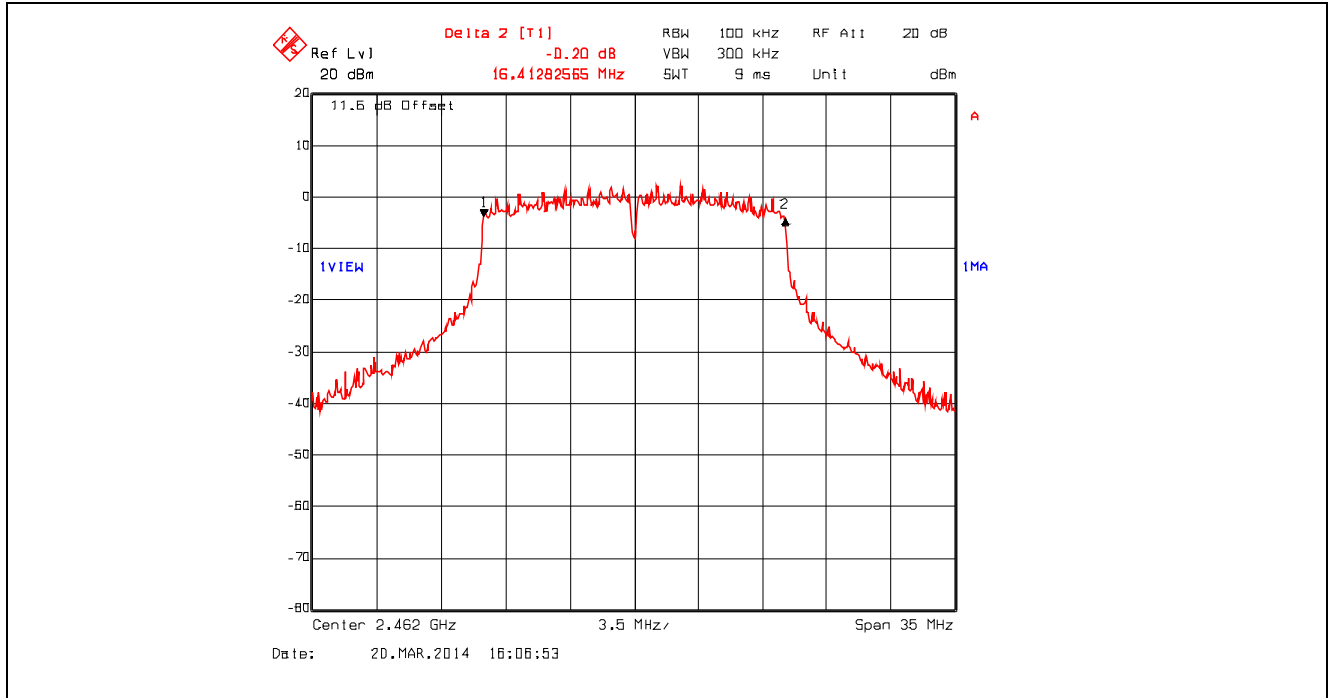

Plot 5.2.4.22. 6 dB Bandwidth, 802.11n 800ns, 6.5 Mbps BPSK1/2, 2412 MHz

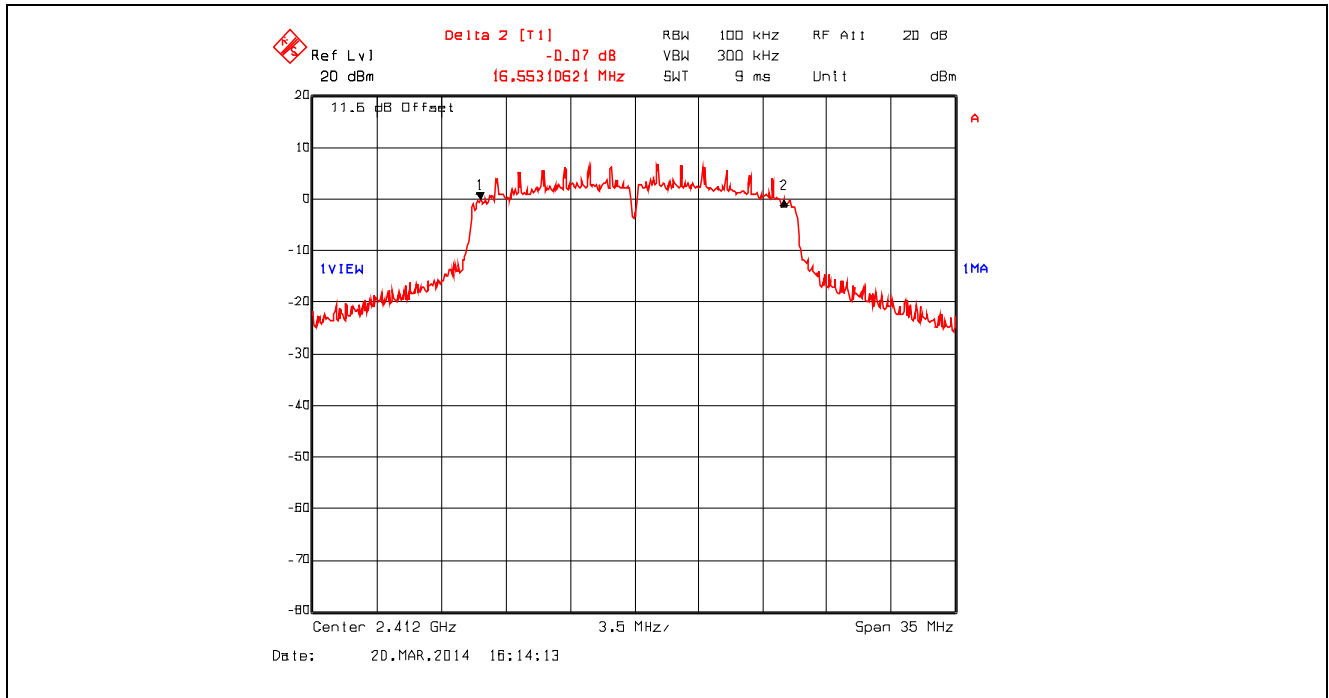

Plot 5.2.4.23. 6 dB Bandwidth, 802.11n 800ns, 6.5 Mbps BPSK1/2, 2437 MHz

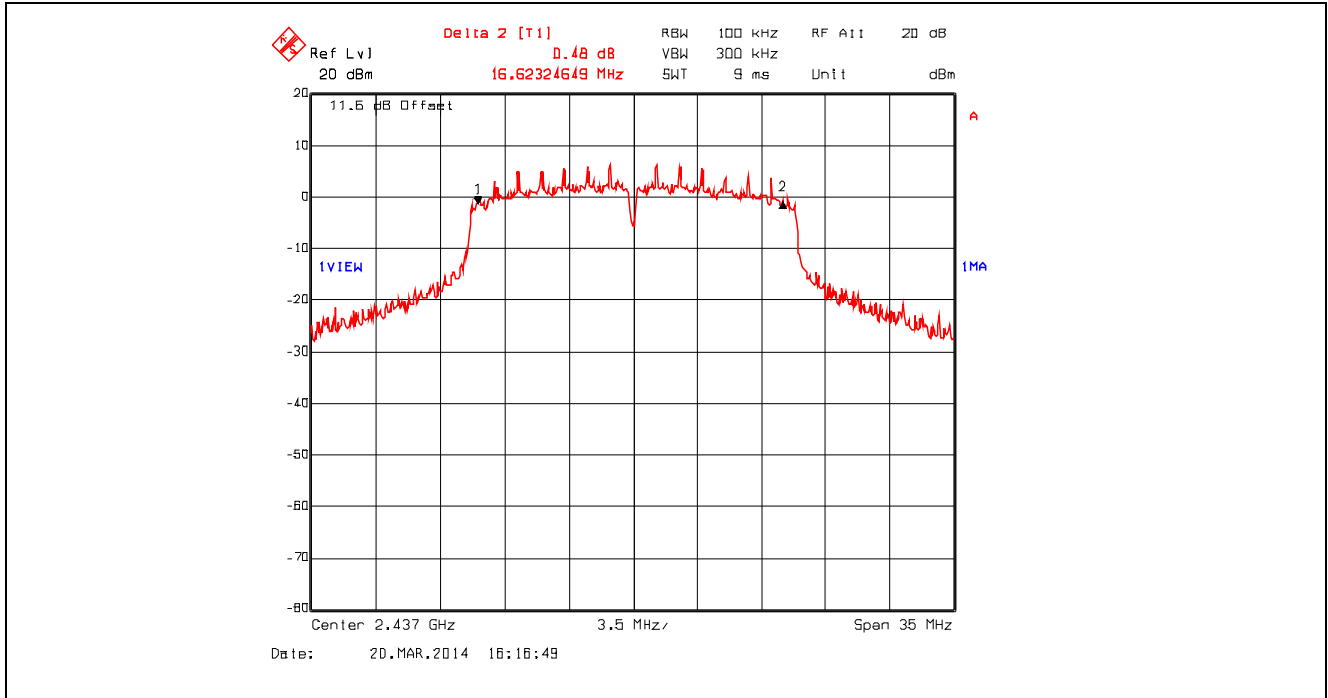

Plot 5.2.4.24. 6 dB Bandwidth, 802.11n 800ns, 6.5 Mbps BPSK1/2, 2462 MHz

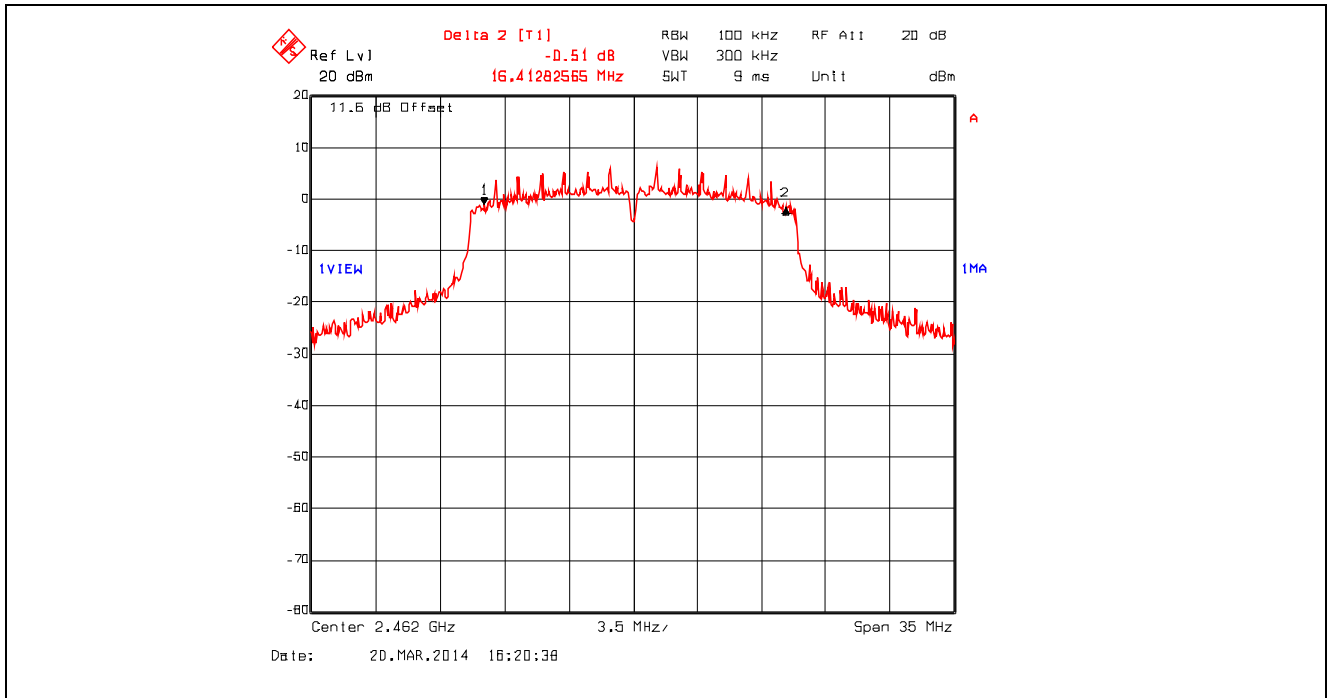

Plot 5.2.4.25. 6 dB Bandwidth, 802.11n 800ns, 19.5 Mbps QPSK 3/4, 2412 MHz

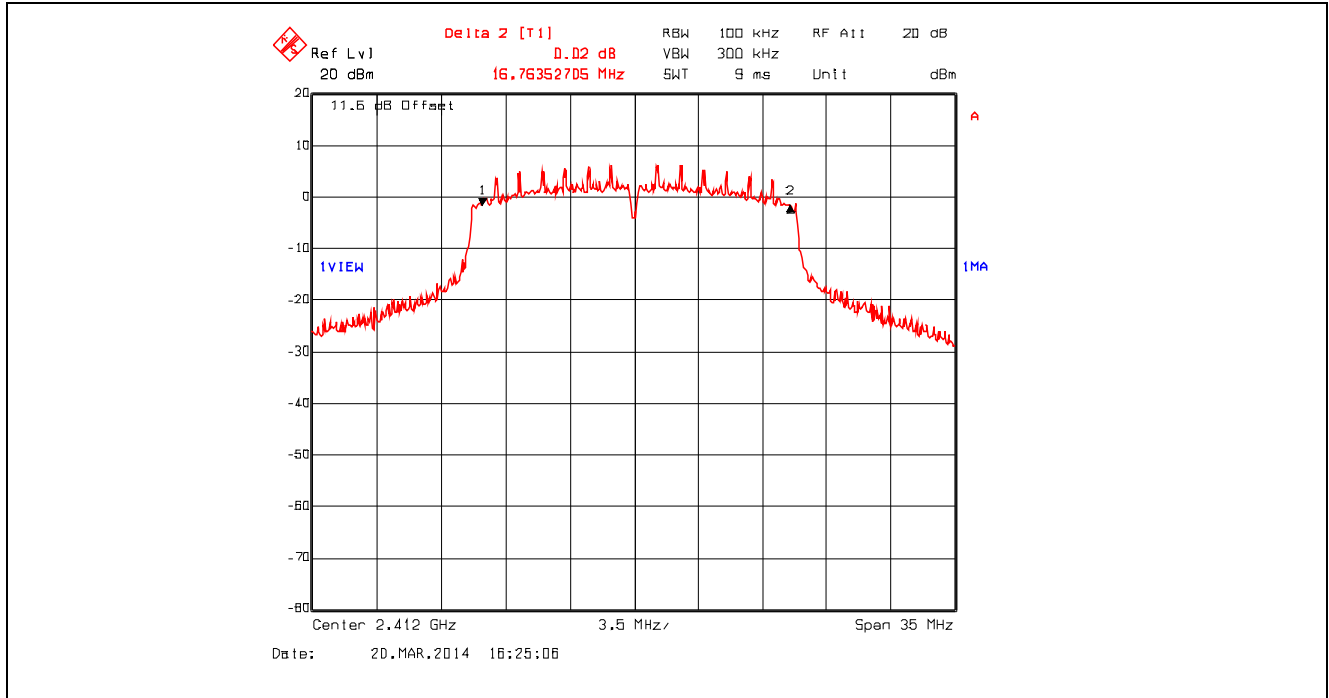

Plot 5.2.4.26. 6 dB Bandwidth, 802.11n 800ns, 19.5 Mbps QPSK 3/4, 2437 MHz

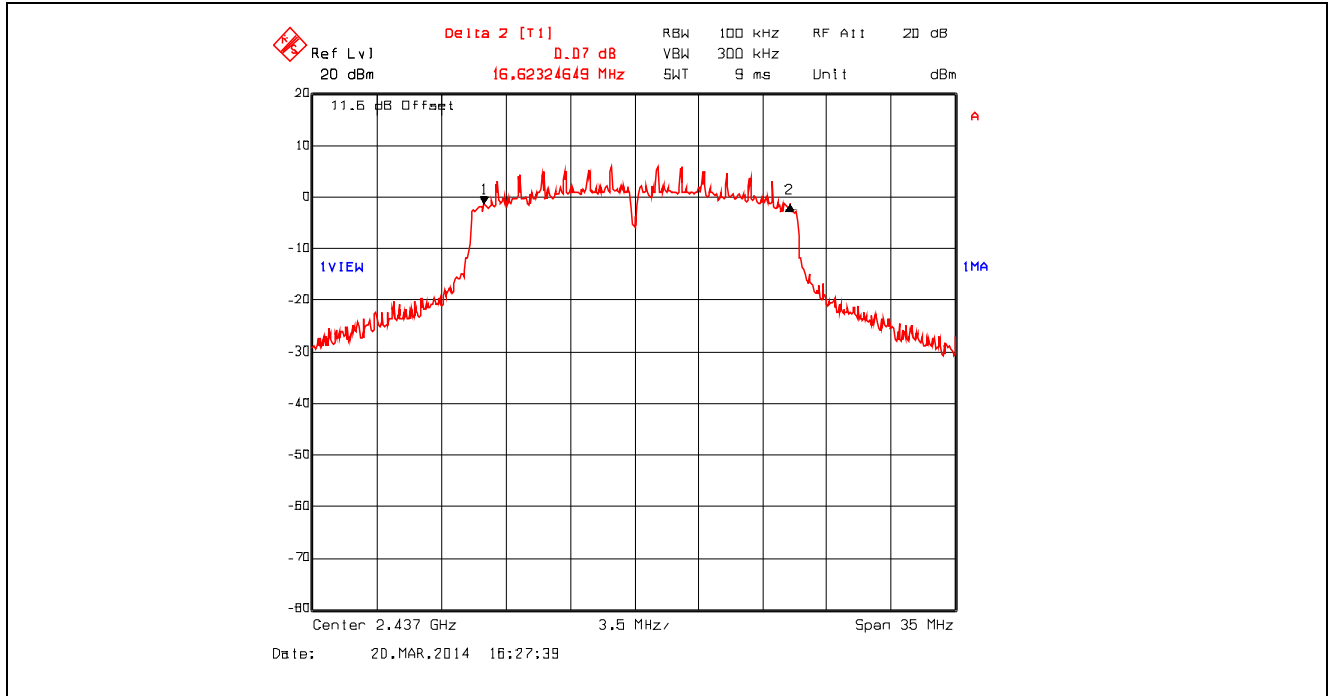

Plot 5.2.4.27. 6 dB Bandwidth, 802.11n 800ns, 19.5 Mbps QPSK 3/4, 2462 MHz

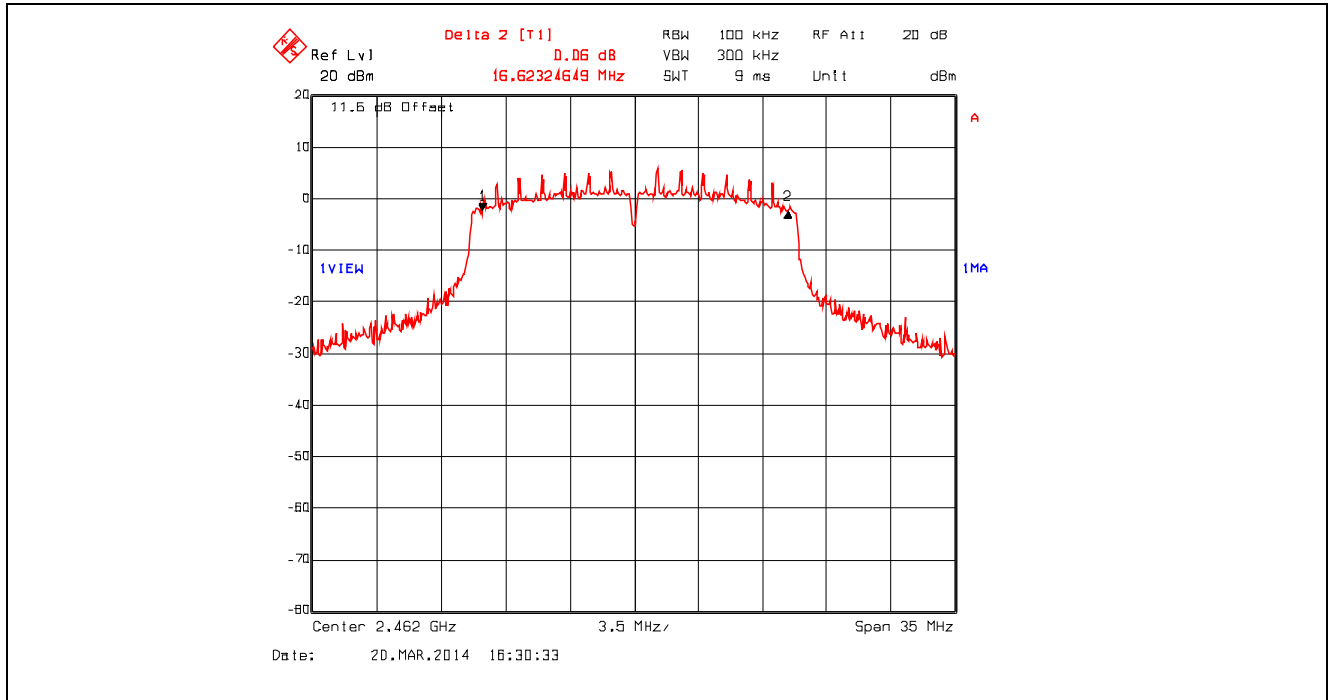

Plot 5.2.4.28. 6 dB Bandwidth, 802.11n 800ns, 39 Mbps 16-QAM 3/4, 2412 MHz

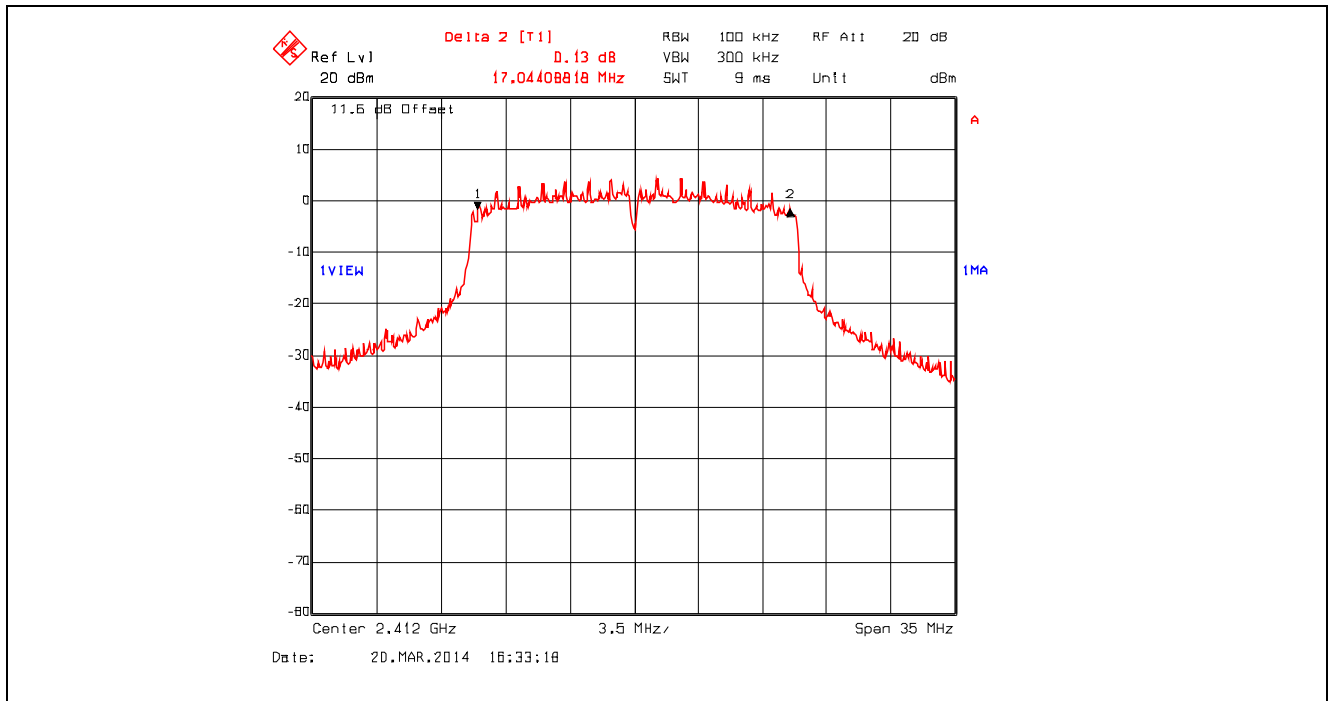

Plot 5.2.4.29. 6 dB Bandwidth, 802.11n 800ns, 39 Mbps 16-QAM 3/4, 2437 MHz

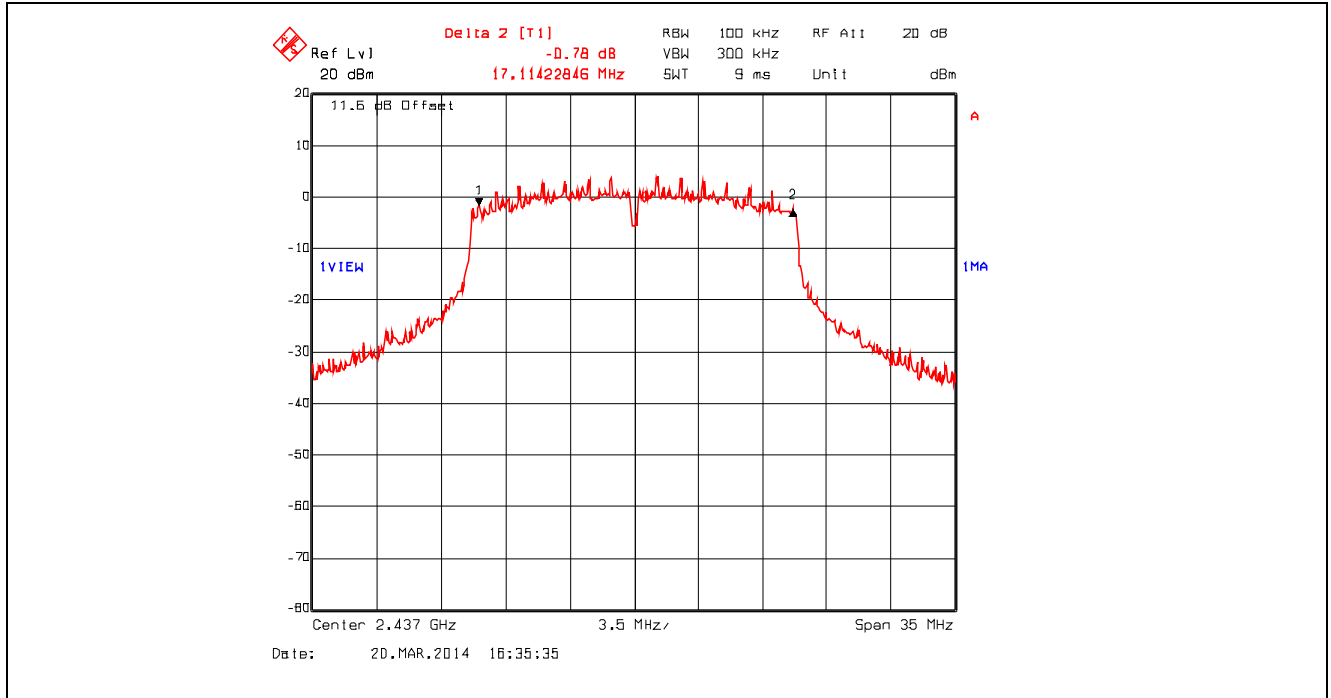

Plot 5.2.4.30. 6 dB Bandwidth, 802.11n 800ns, 39 Mbps 16-QAM 3/4, 2462 MHz

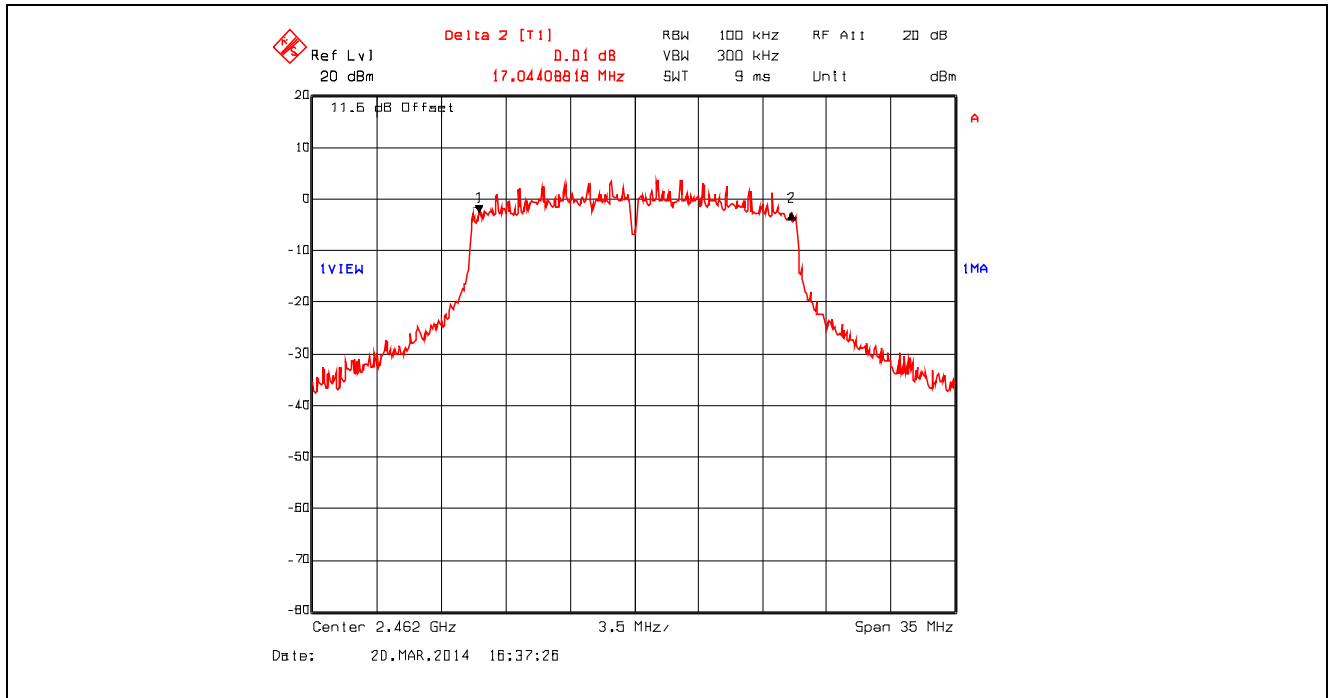

Plot 5.2.4.31. 6 dB Bandwidth, 802.11n 800ns, 65 Mbps 64-QAM 5/6, 2412 MHz

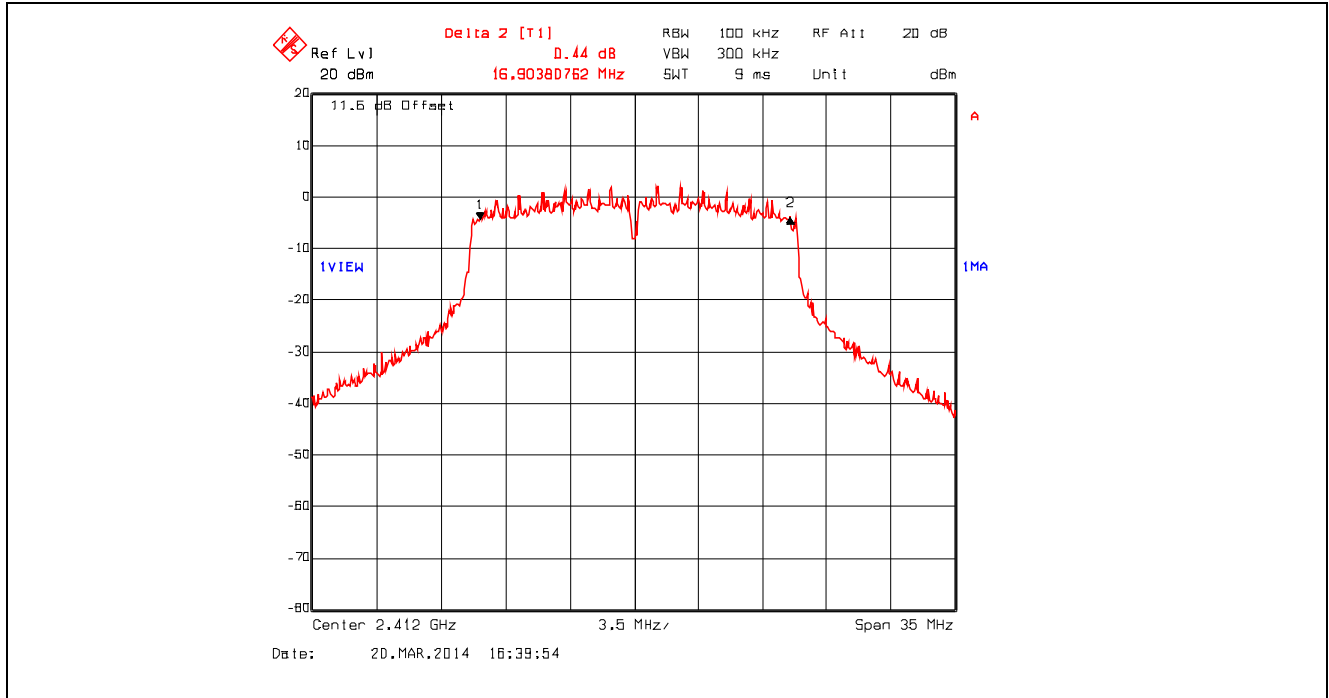

Plot 5.2.4.32. 6 dB Bandwidth, 802.11n 800ns, 65 Mbps 64-QAM 5/6, 2437 MHz

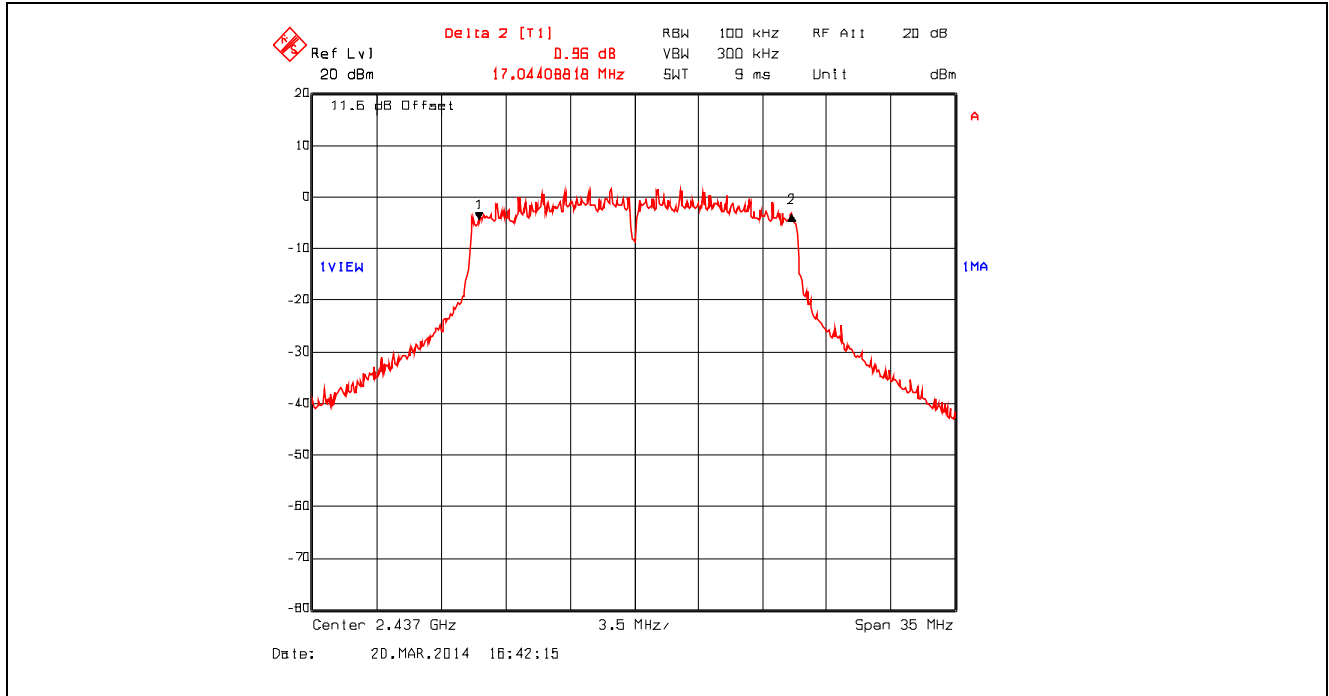

Plot 5.2.4.33. 6 dB Bandwidth, 802.11n 800ns, 65 Mbps 64-QAM 5/6, 2462 MHz

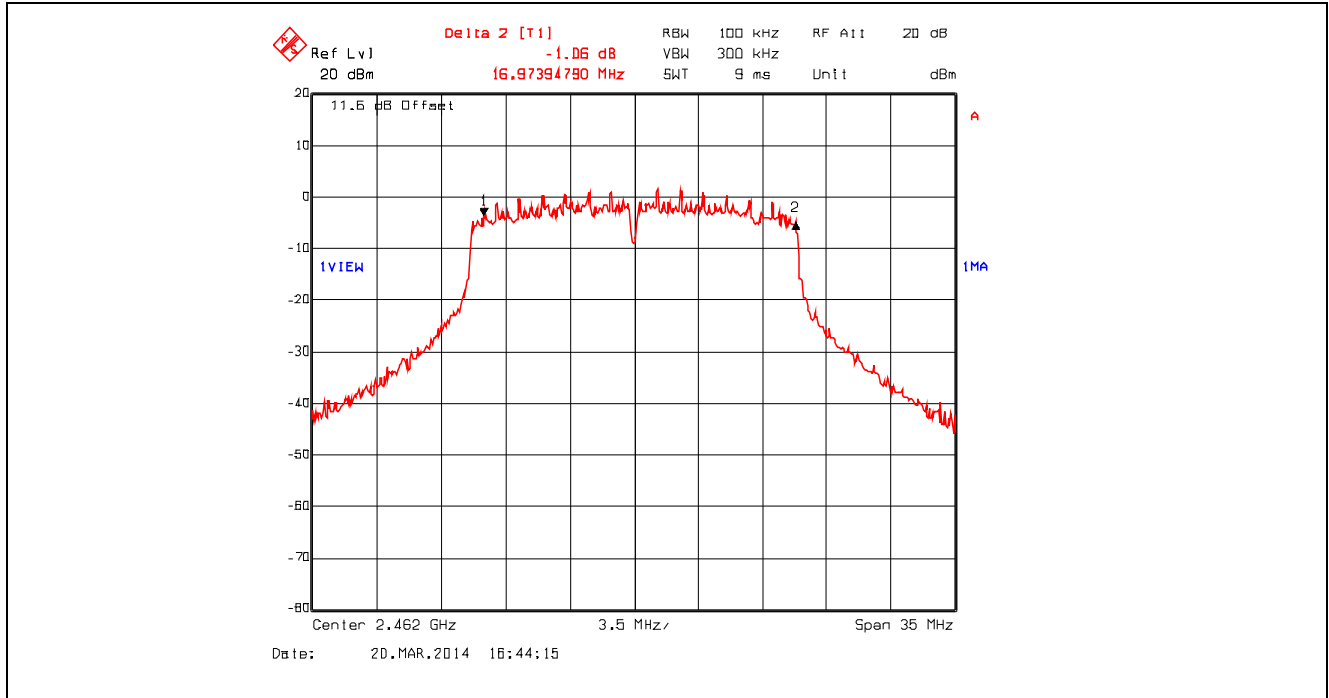

Plot 5.2.4.34. 99% Occupied Bandwidth, 802.11b, 1 Mbps DBPSK, 2412 MHz

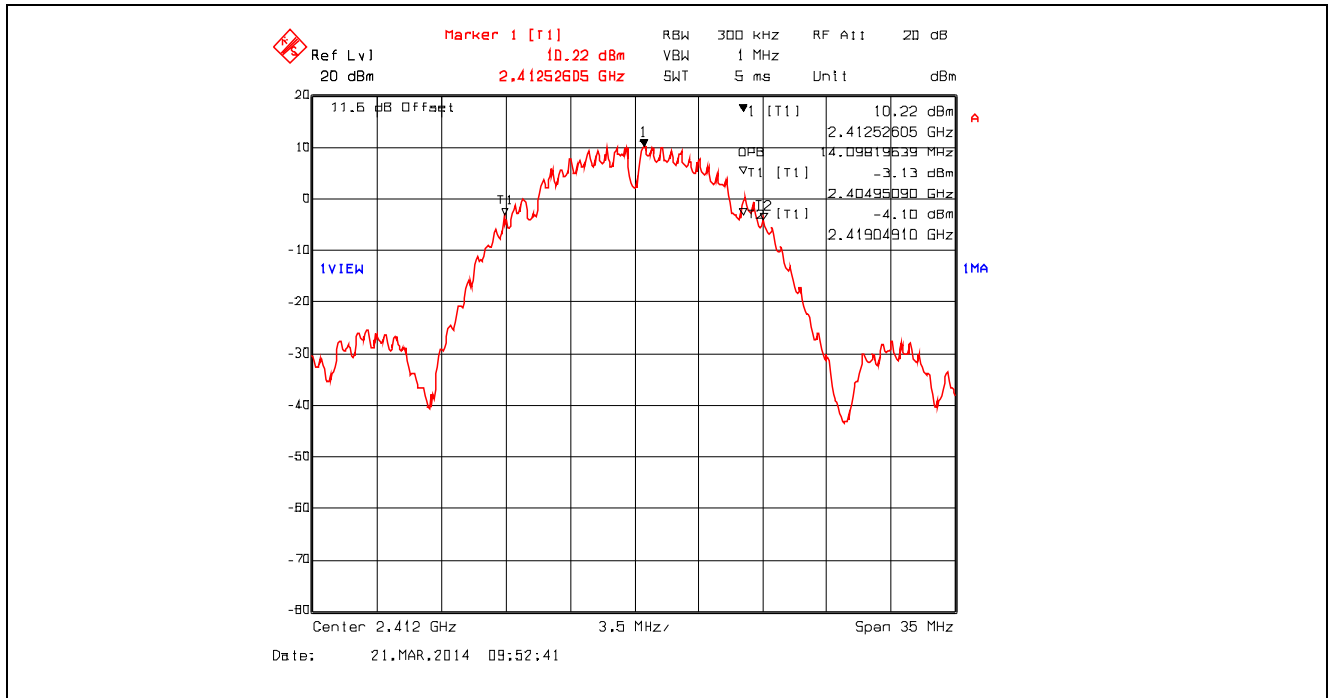

Plot 5.2.4.35. 99% Occupied Bandwidth, 802.11b, 1 Mbps DBPSK, 2437 MHz

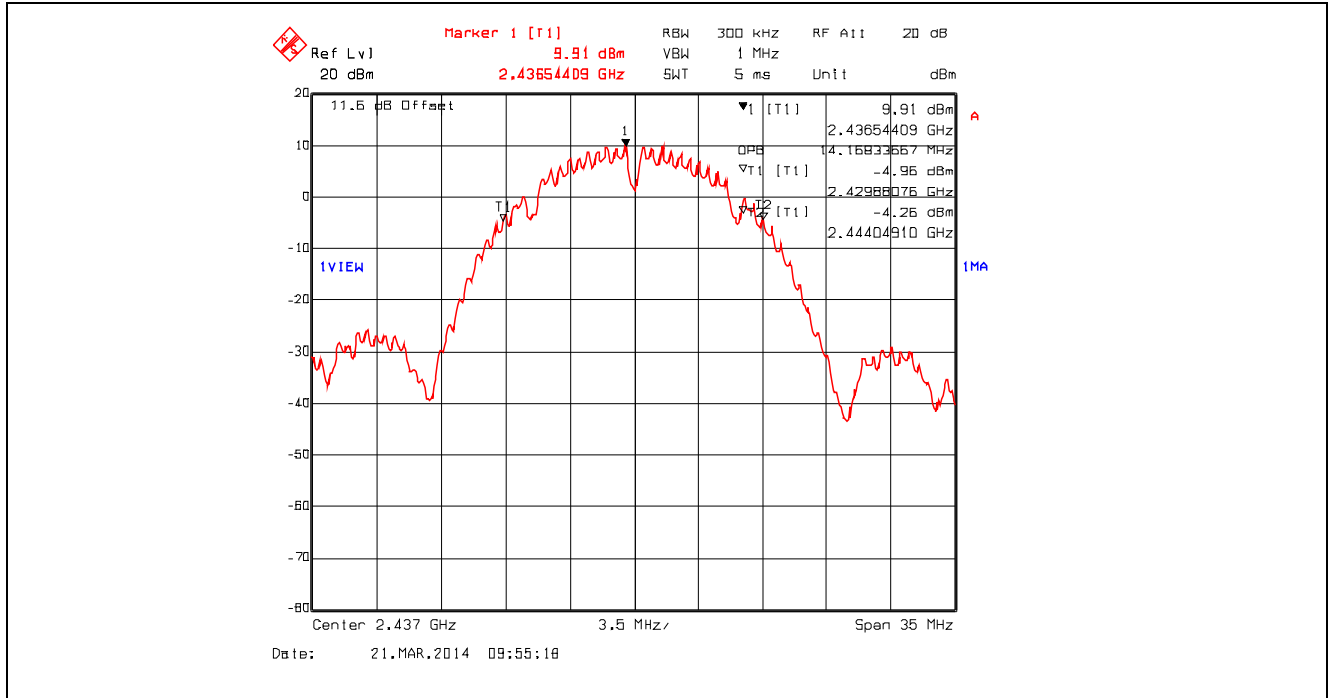

Plot 5.2.4.36. 99% Occupied Bandwidth, 802.11b, 1 Mbps DBPSK, 2462 MHz

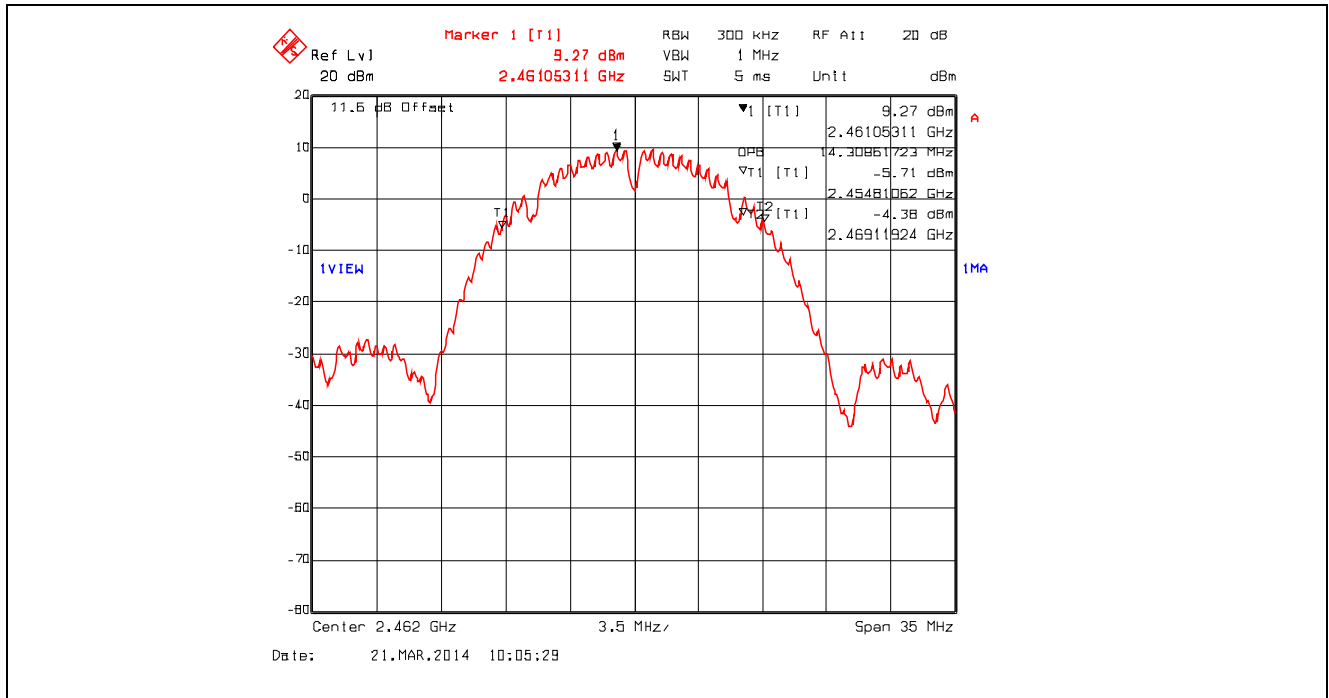

Plot 5.2.4.37. 99% Occupied Bandwidth, 802.11b, 2 Mbps DQPSK, 2412 MHz

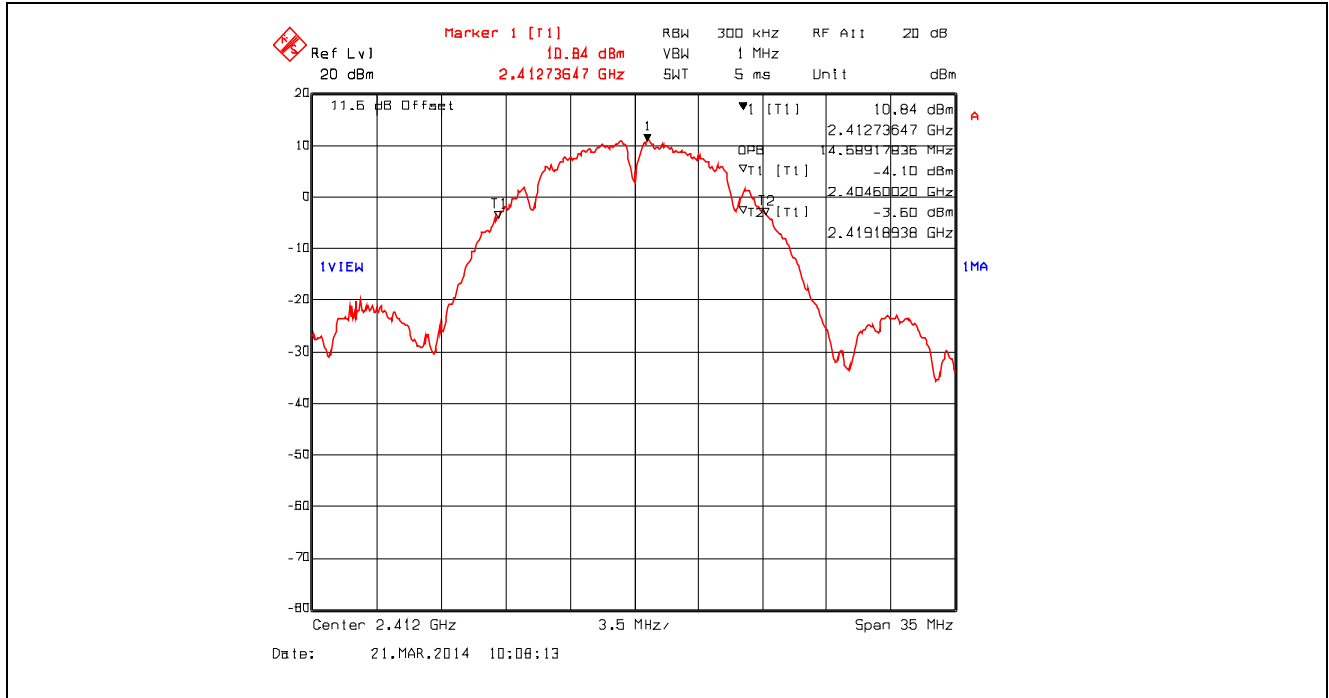

Plot 5.2.4.38. 99% Occupied Bandwidth, 802.11b, 2 Mbps DQPSK, 2437 MHz

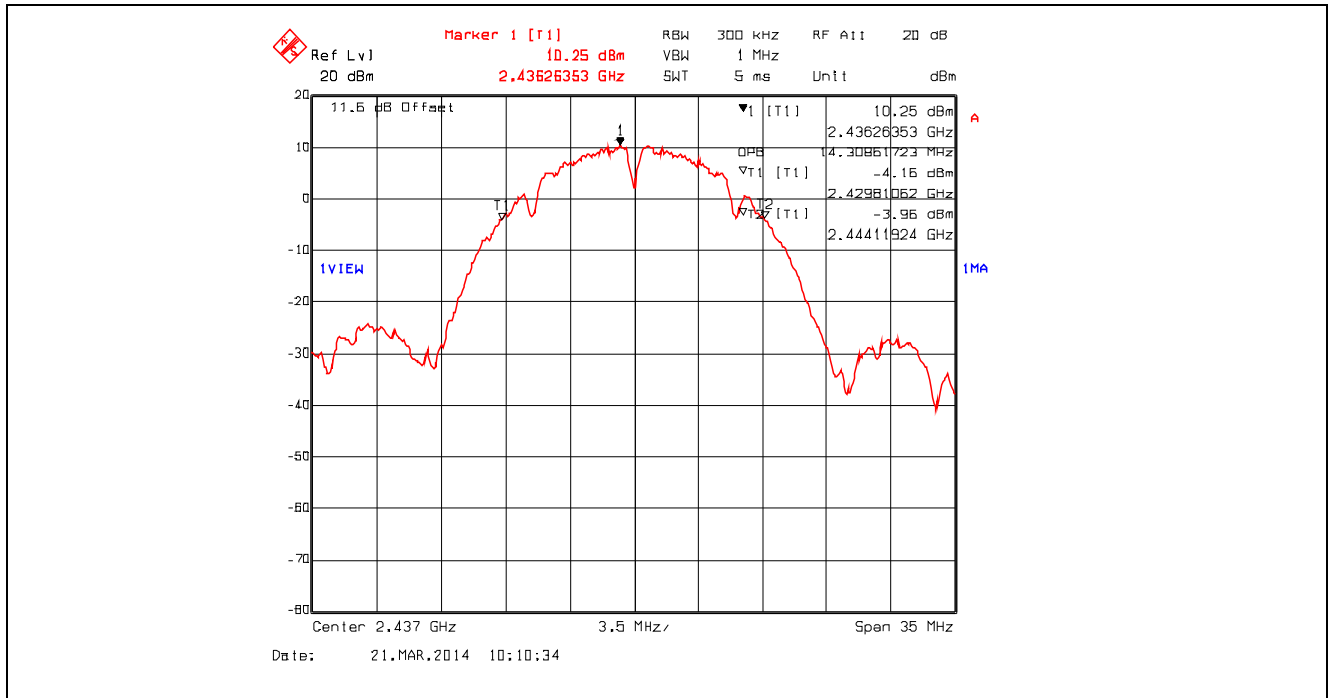

Plot 5.2.4.39. 99% Occupied Bandwidth, 802.11b, 2 Mbps DQPSK, 2462 MHz

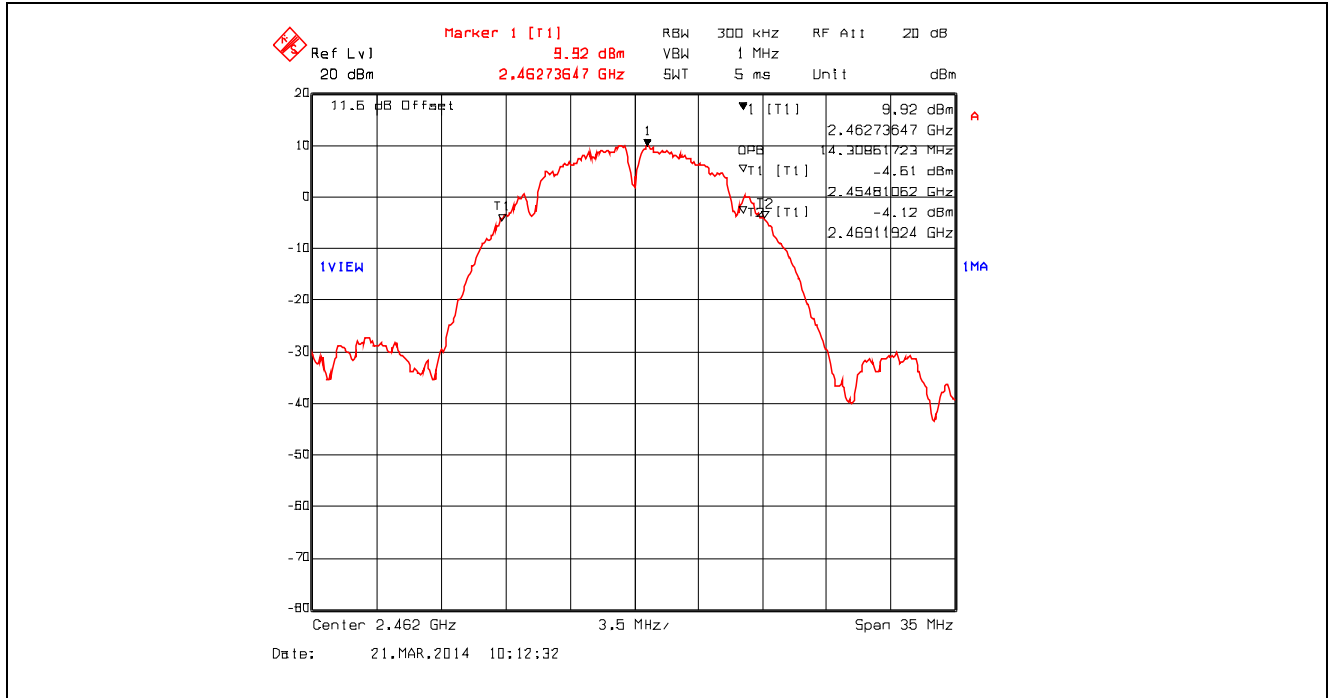

Plot 5.2.4.40. 99% Occupied Bandwidth, 802.11b, 11 Mbps CCK, 2412 MHz

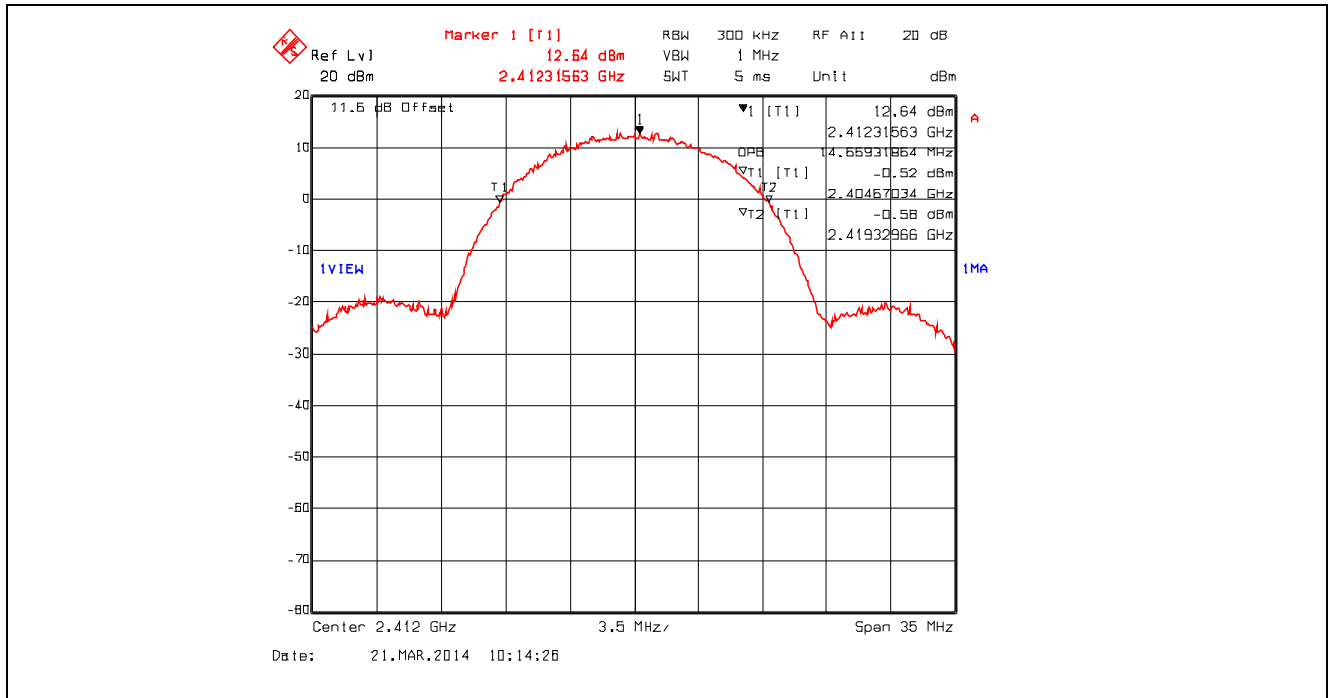

Plot 5.2.4.41. 99% Occupied Bandwidth, 802.11b, 11 Mbps CCK, 2437 MHz

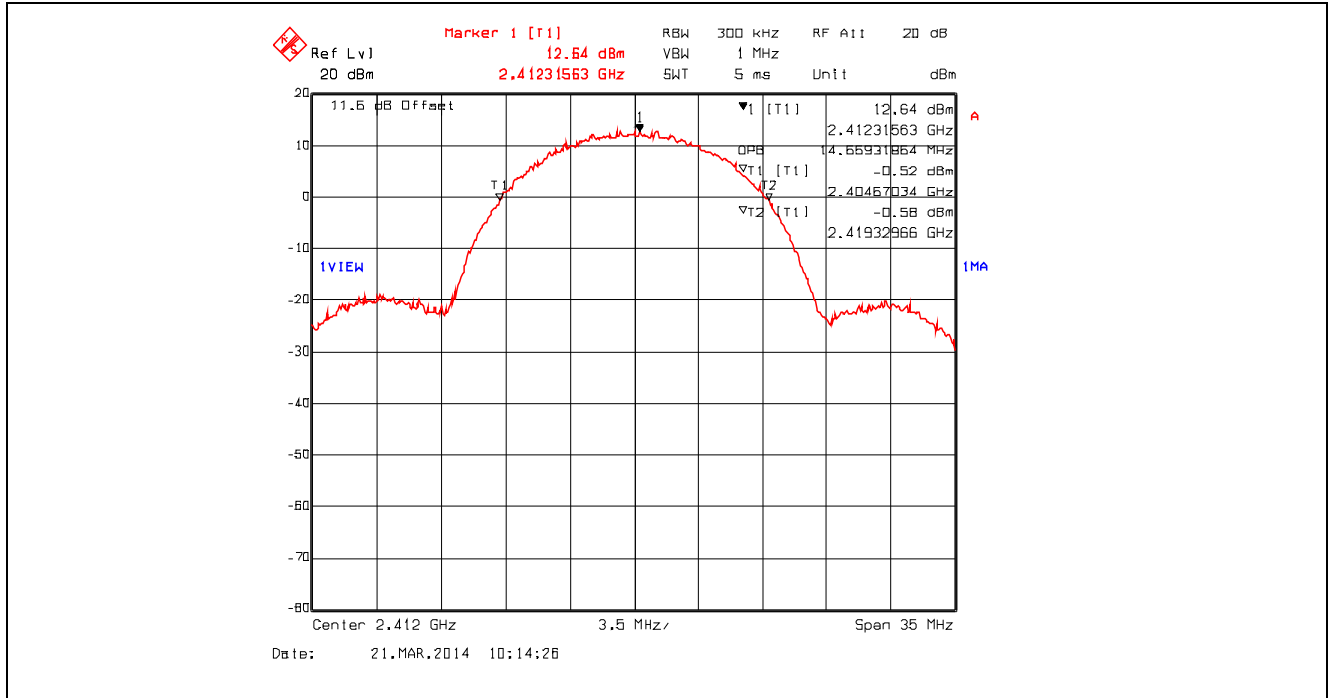

Plot 5.2.4.42. 99% Occupied Bandwidth, 802.11b, 11 Mbps CCK, 2462 MHz

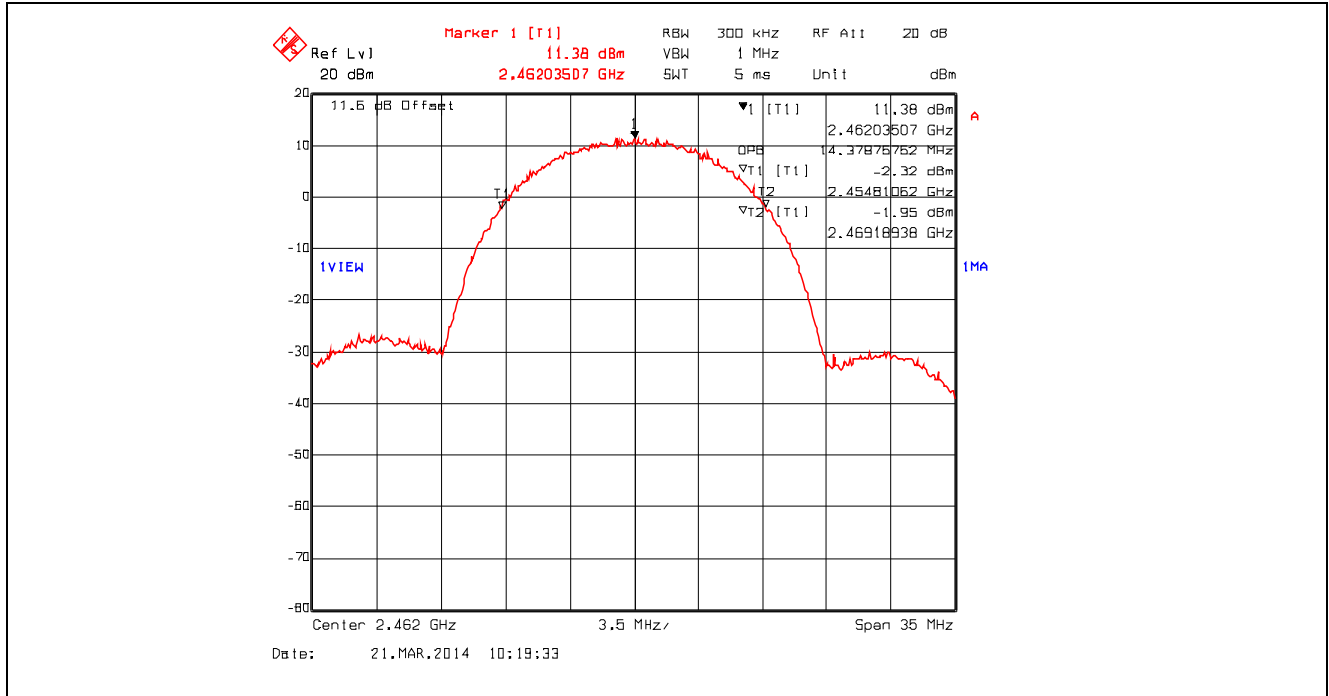

Plot 5.2.4.43. 99% Occupied Bandwidth, 802.11g, 9 Mbps BPSK, 2412 MHz

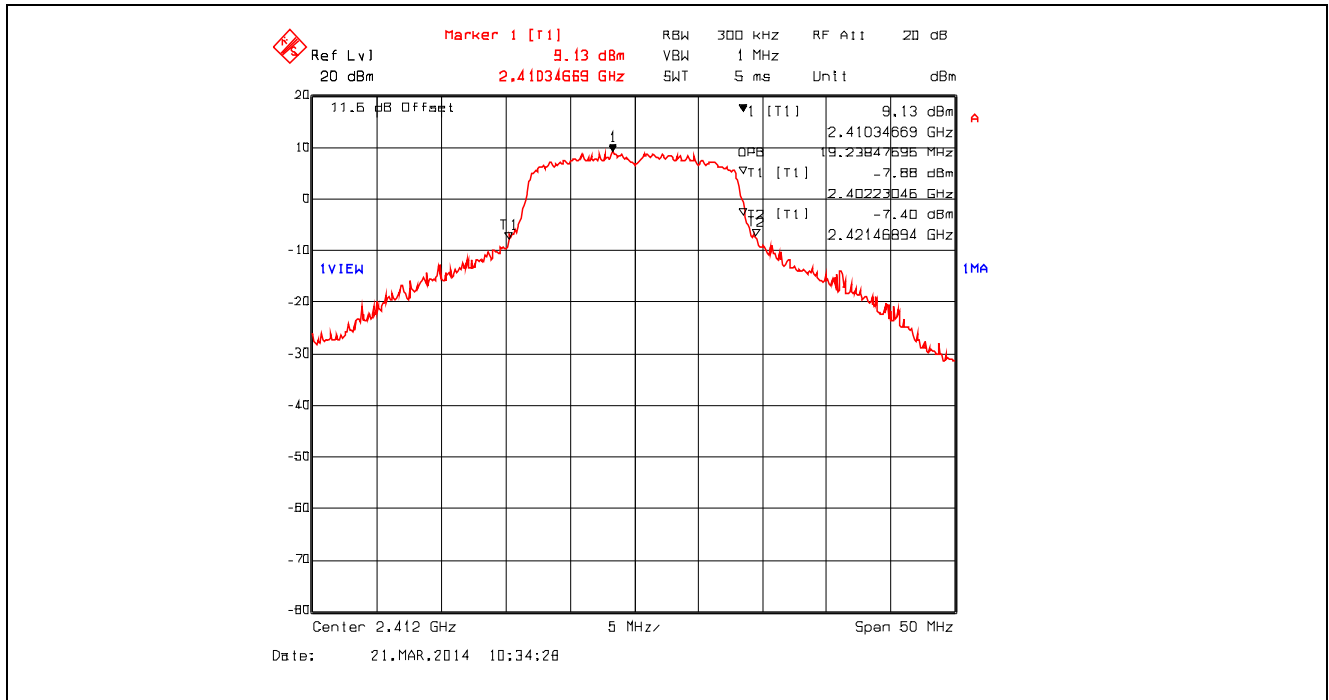

Plot 5.2.4.44. 99% Occupied Bandwidth, 802.11g, 9 Mbps BPSK, 2437 MHz

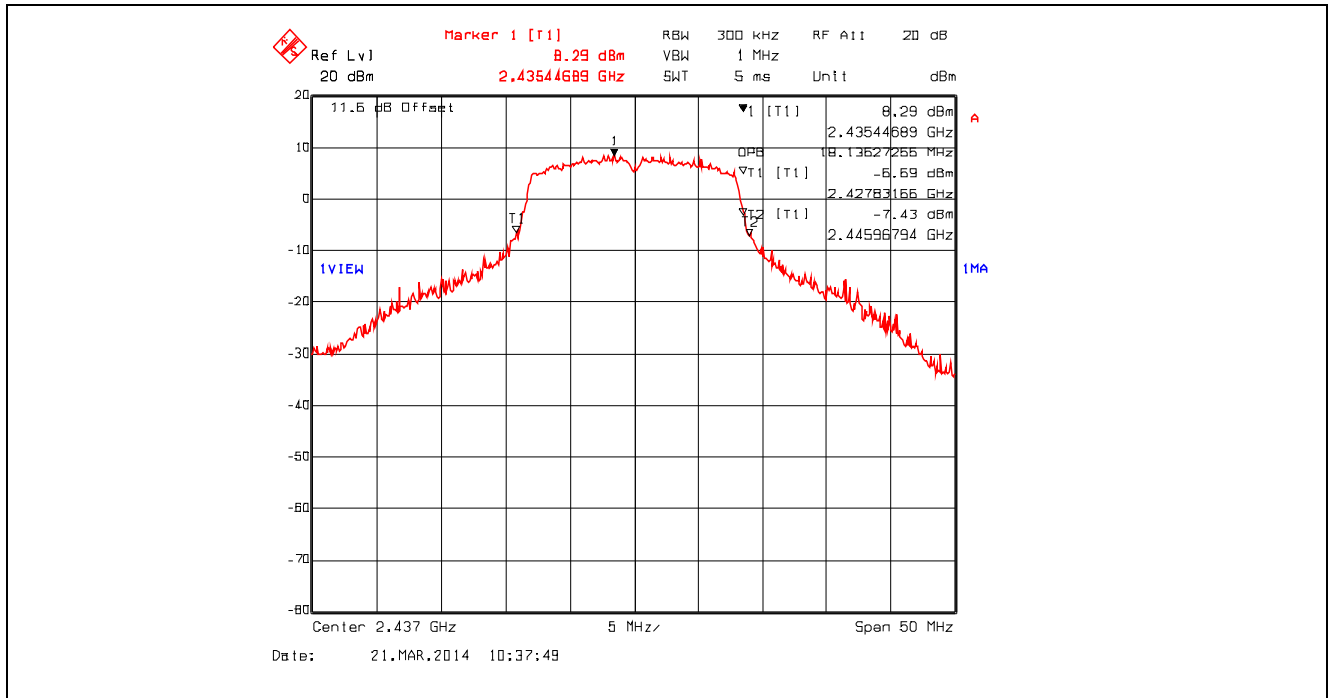

Plot 5.2.4.45. 99% Occupied Bandwidth, 802.11g, 9 Mbps BPSK, 2462 MHz

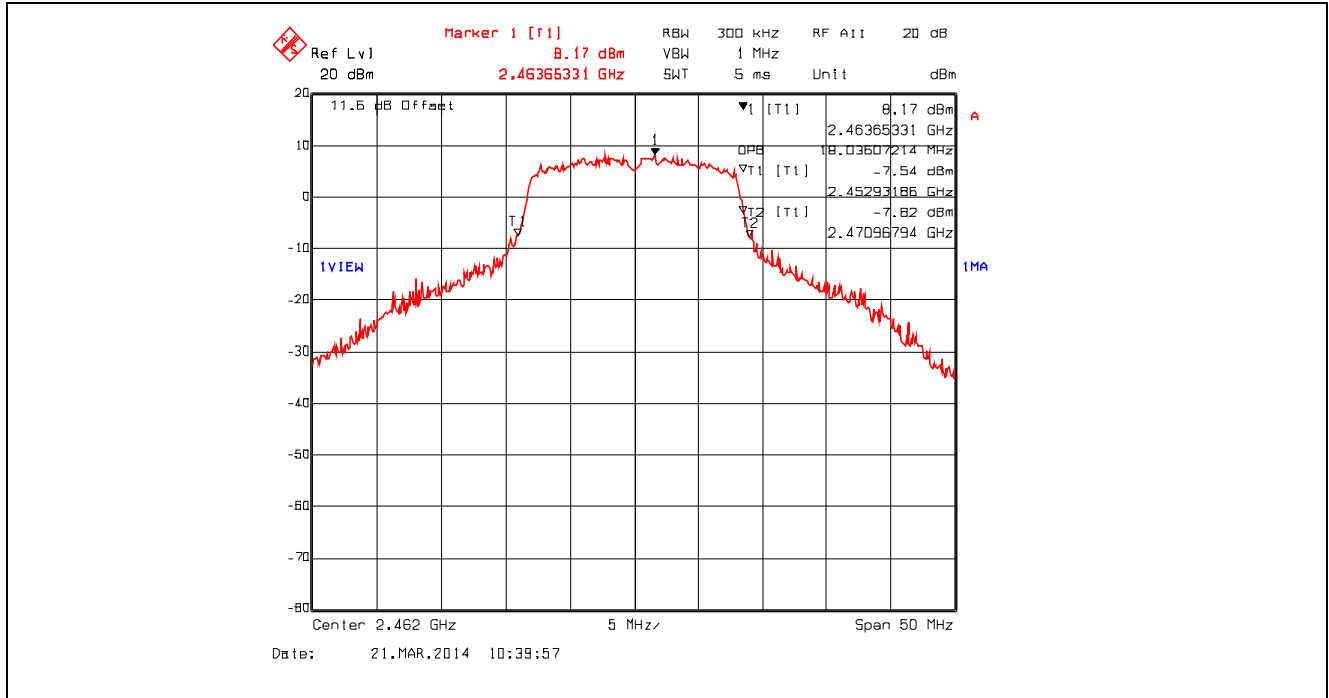

Plot 5.2.4.46. 99% Occupied Bandwidth, 802.11g, 18 Mbps QPSK, 2412 MHz

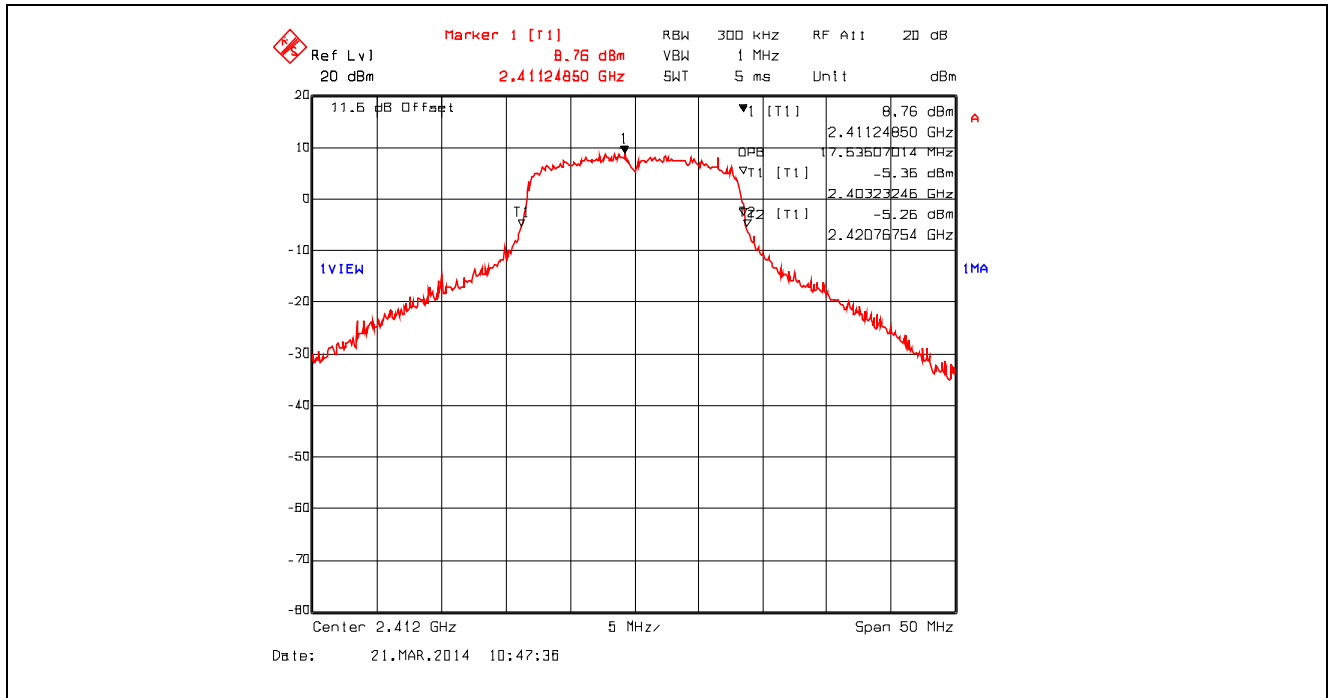

Plot 5.2.4.47. 99% Occupied Bandwidth, 802.11g, 18 Mbps QPSK, 2437 MHz

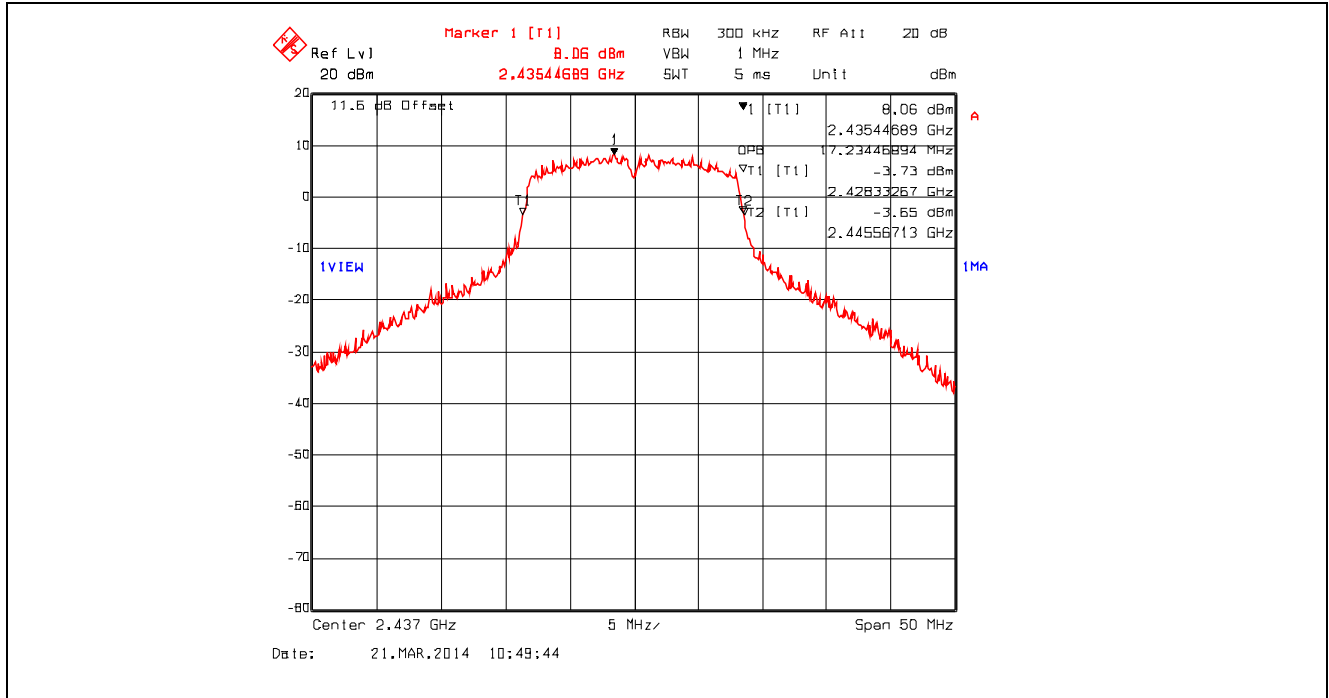

Plot 5.2.4.48. 99% Occupied Bandwidth, 802.11g, 18 Mbps QPSK, 2462 MHz

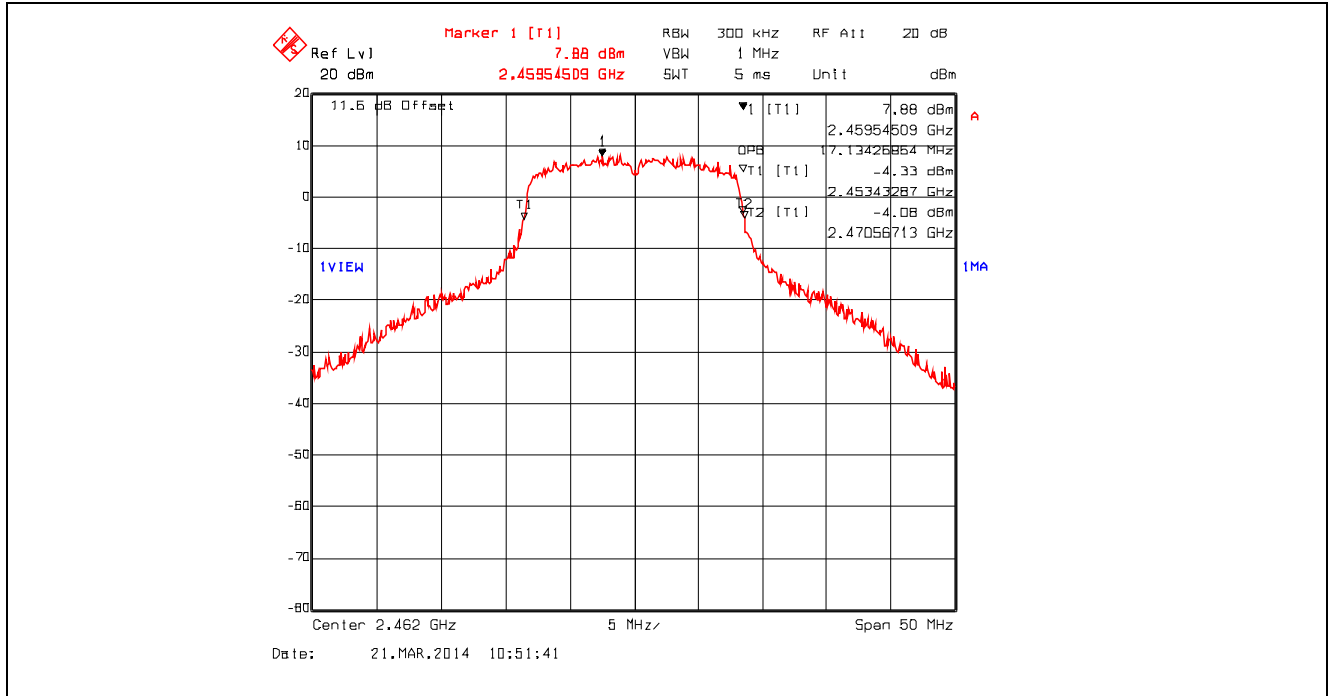

Plot 5.2.4.49. 99% Occupied Bandwidth, 802.11g, 36 Mbps 16-QAM, 2412 MHz

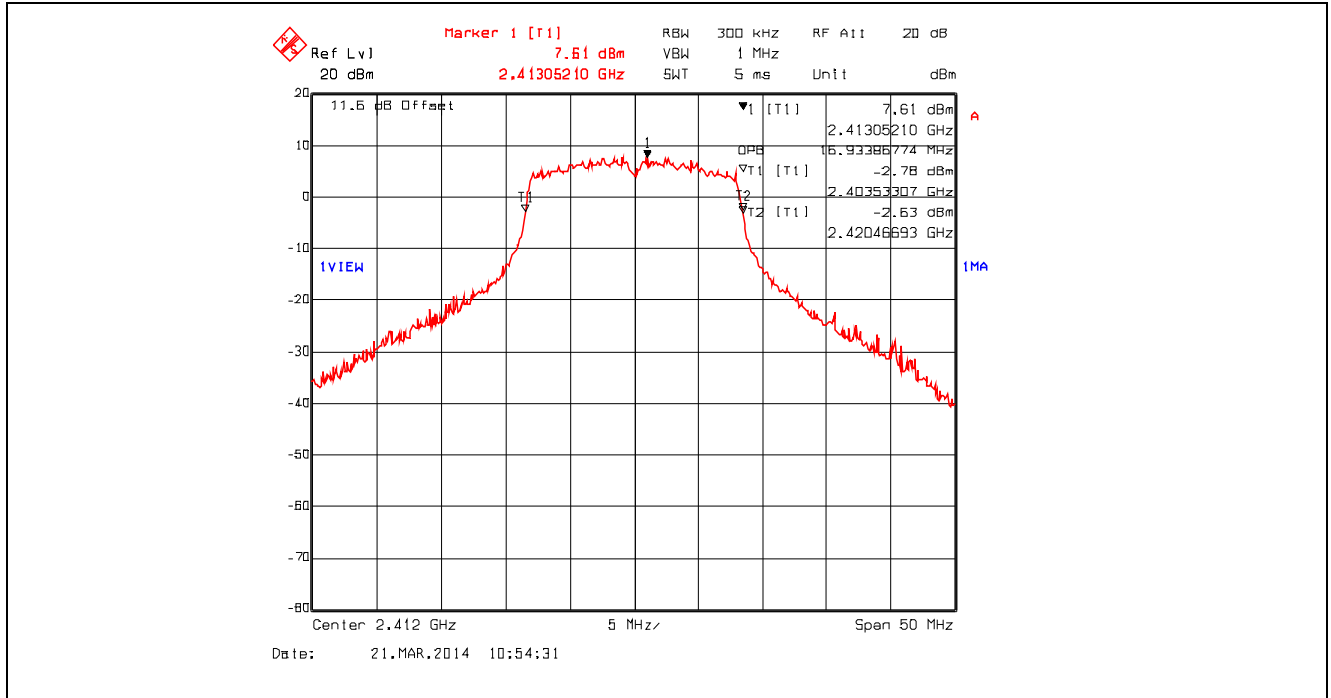

Plot 5.2.4.50. 99% Occupied Bandwidth, 802.11g, 36 Mbps 16-QAM, 2437 MHz

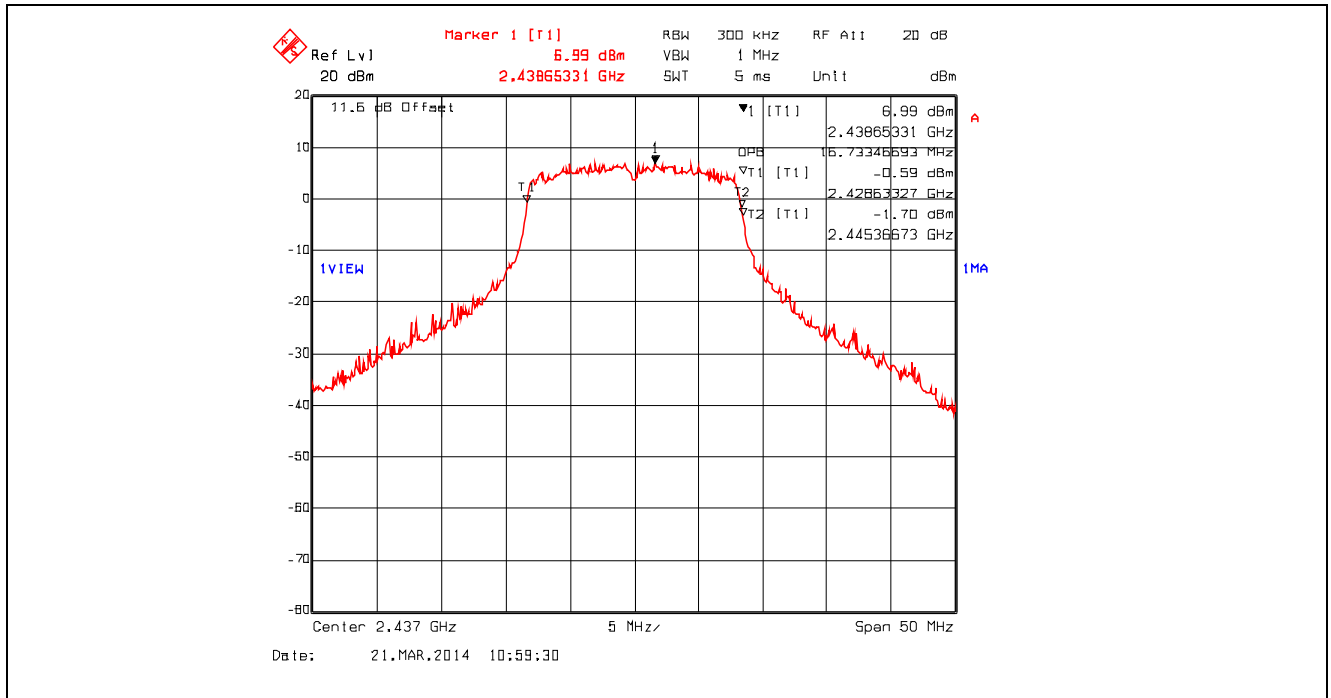

Plot 5.2.4.51. 99% Occupied Bandwidth, 802.11g, 36 Mbps 16-QAM, 2462 MHz

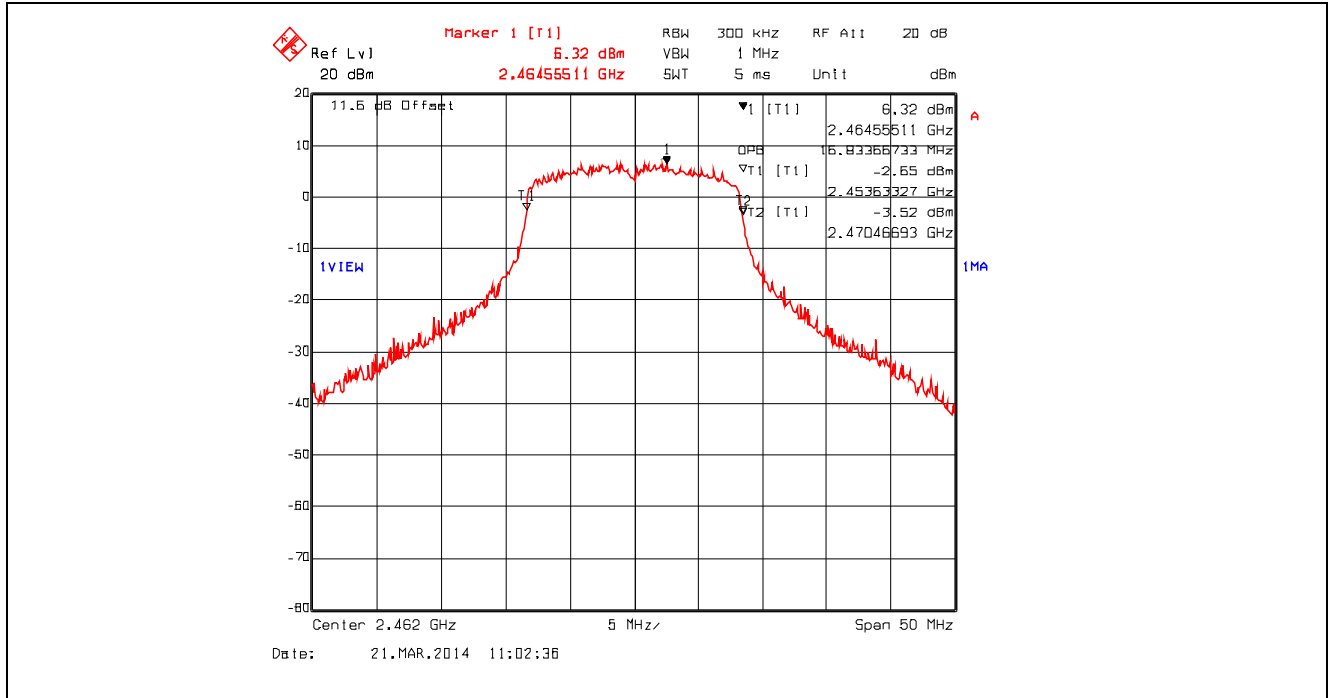

Plot 5.2.4.52. 99% Occupied Bandwidth, 802.11g, 54 Mbps 64-QAM, 2412 MHz

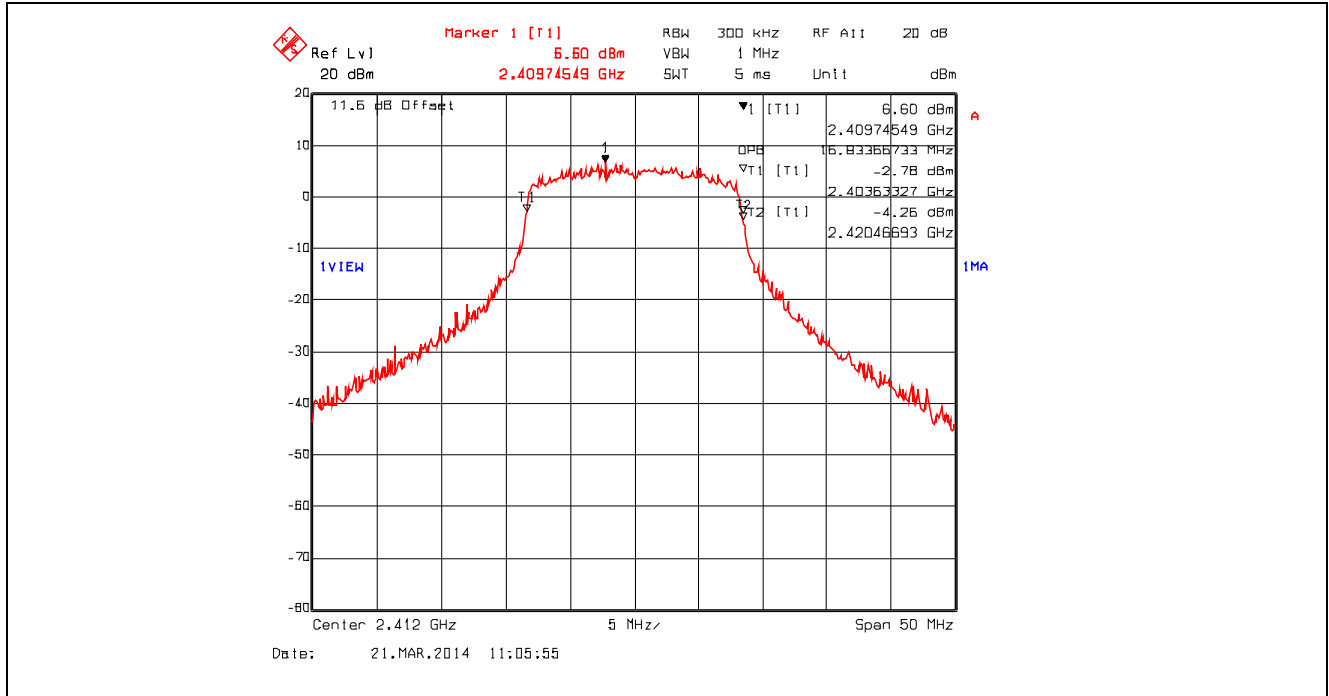

Plot 5.2.4.53. 99% Occupied Bandwidth, 802.11g, 54 Mbps 64-QAM, 2437 MHz

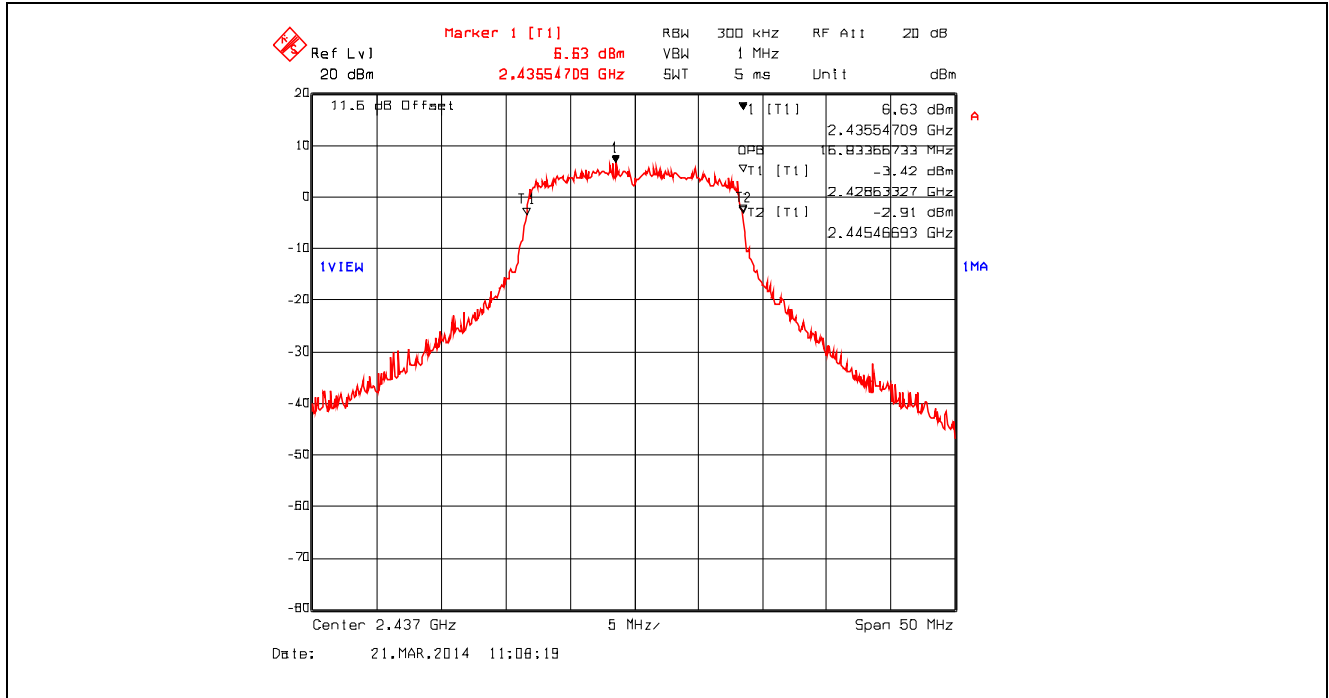

Plot 5.2.4.54. 99% Occupied Bandwidth, 802.11g, 54 Mbps 64-QAM, 2462 MHz

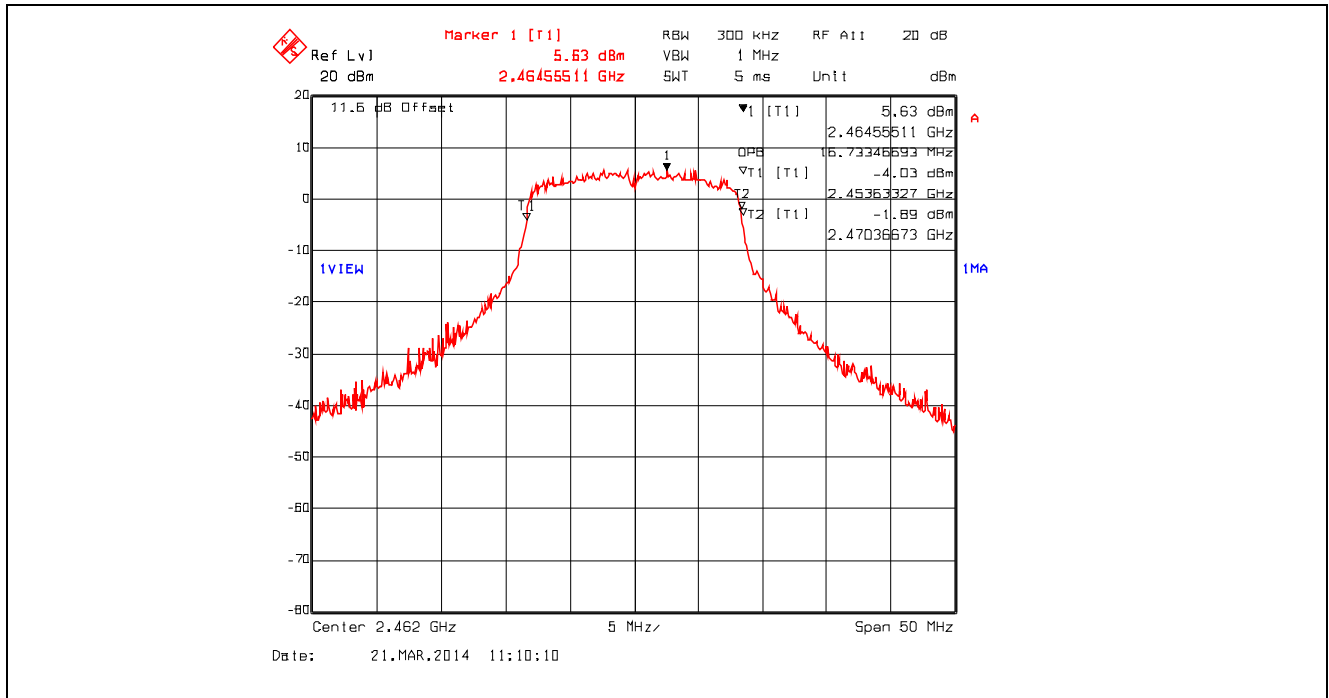

Plot 5.2.4.55. 99% Occupied Bandwidth, 802.11n 800ns, 6.5 Mbps BPSK1/2, 2412 MHz

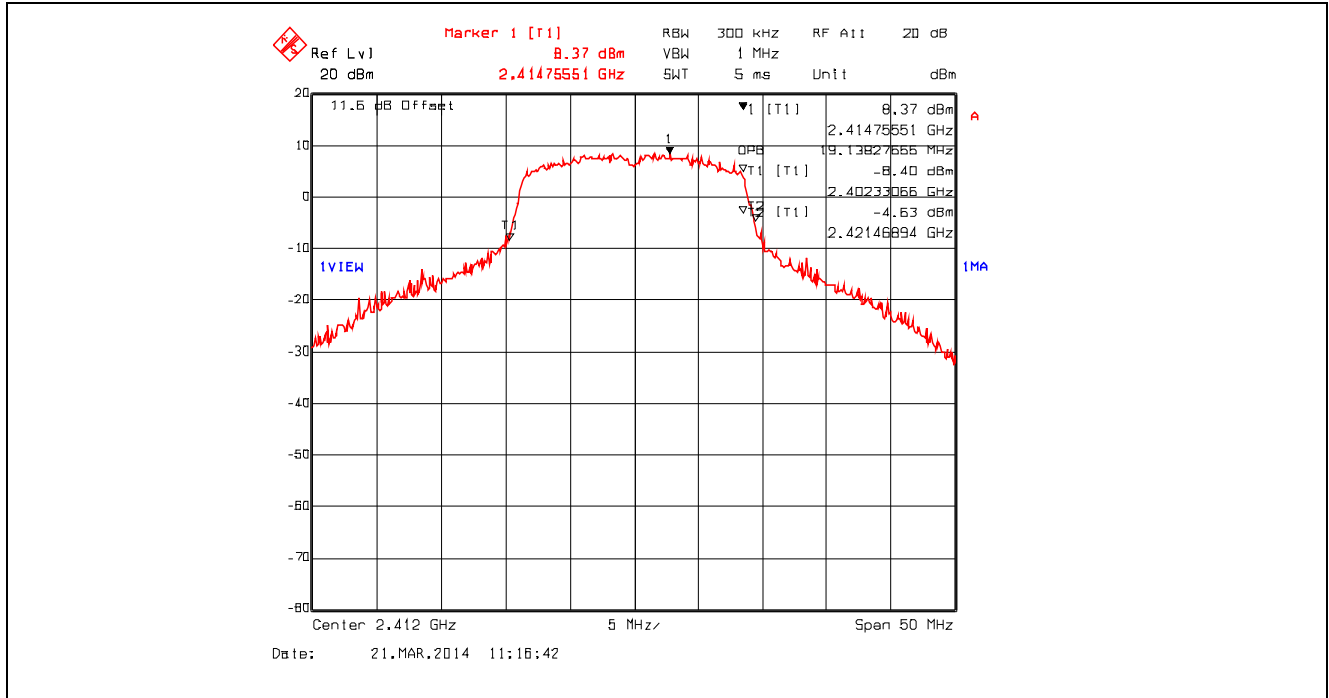

Plot 5.2.4.56. 99% Occupied Bandwidth, 802.11n 800ns, 6.5 Mbps BPSK1/2, 2437 MHz

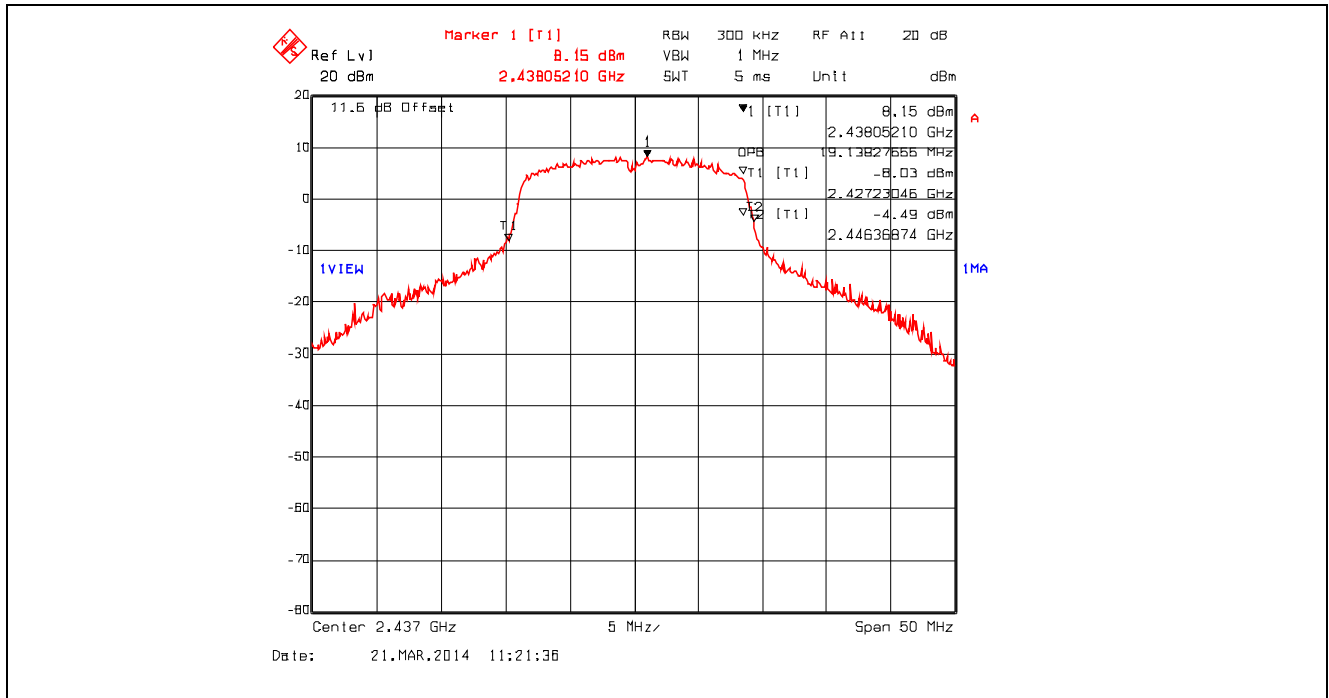

Plot 5.2.4.57. 99% Occupied Bandwidth, 802.11n 800ns, 6.5 Mbps BPSK1/2, 2462 MHz

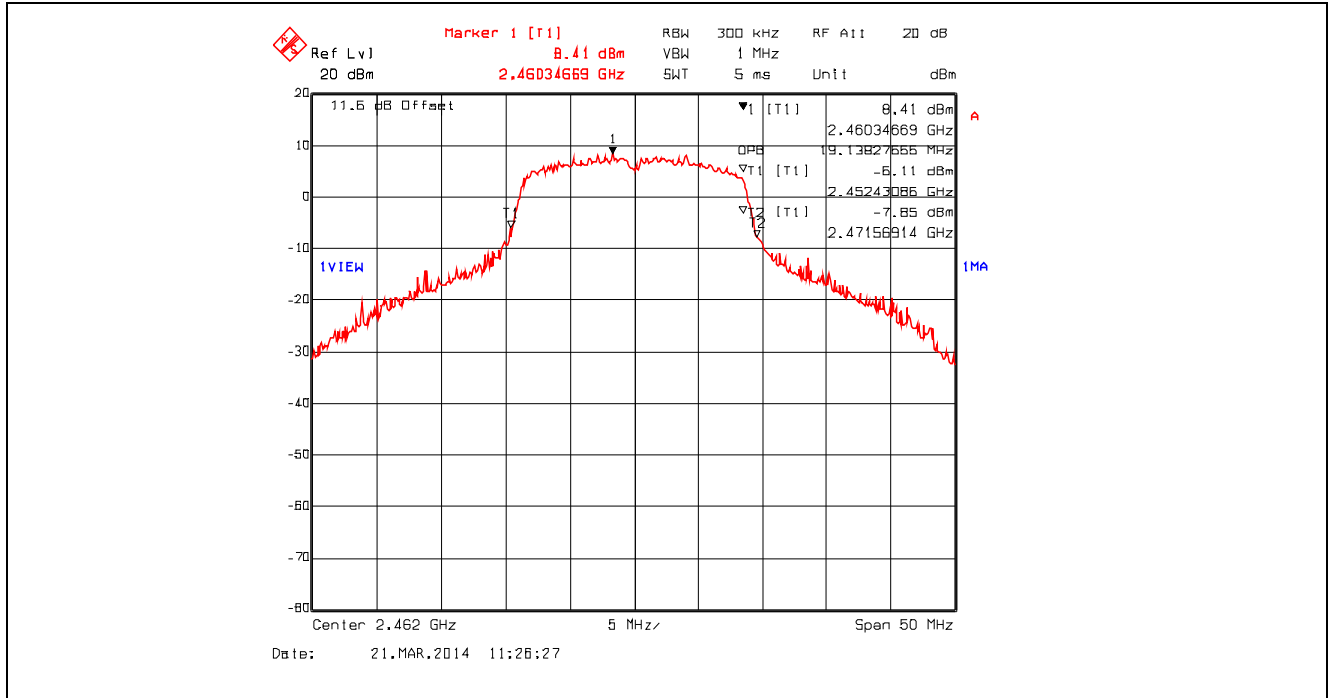

Plot 5.2.4.58. 99% Occupied Bandwidth, 802.11n 800ns, 19.5 Mbps QPSK 3/4, 2412 MHz

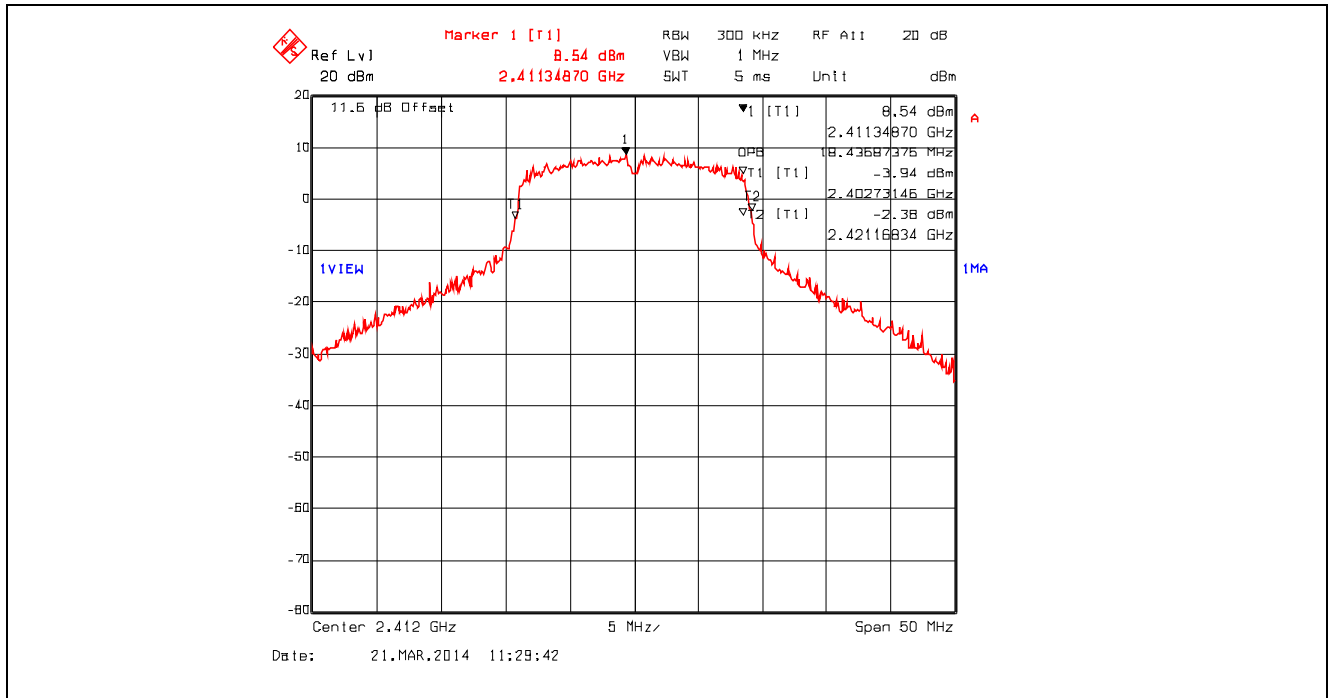

Plot 5.2.4.59. 99% Occupied Bandwidth, 802.11n 800ns, 19.5 Mbps QPSK 3/4, 2437 MHz

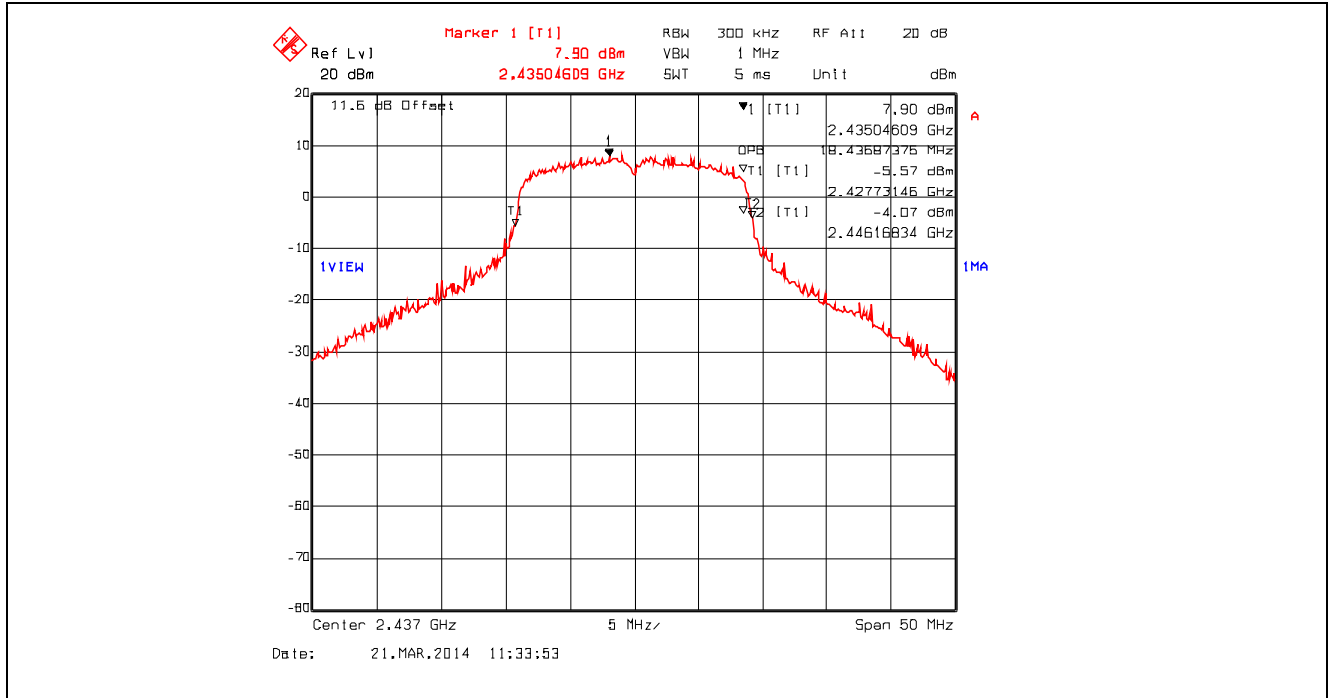

Plot 5.2.4.60. 99% Occupied Bandwidth, 802.11n 800ns, 19.5 Mbps QPSK 3/4, 2462 MHz

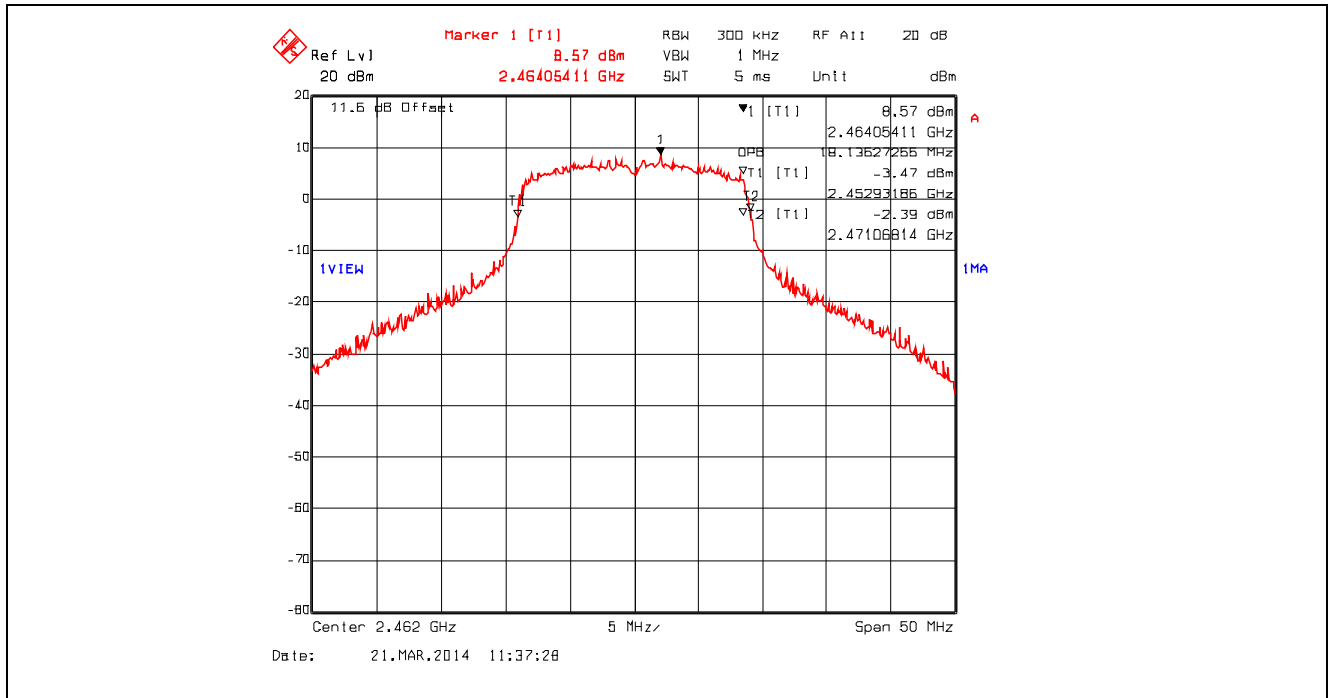

Plot 5.2.4.61. 99% Occupied Bandwidth, 802.11n 800ns, 39 Mbps 16-QAM 3/4, 2412 MHz

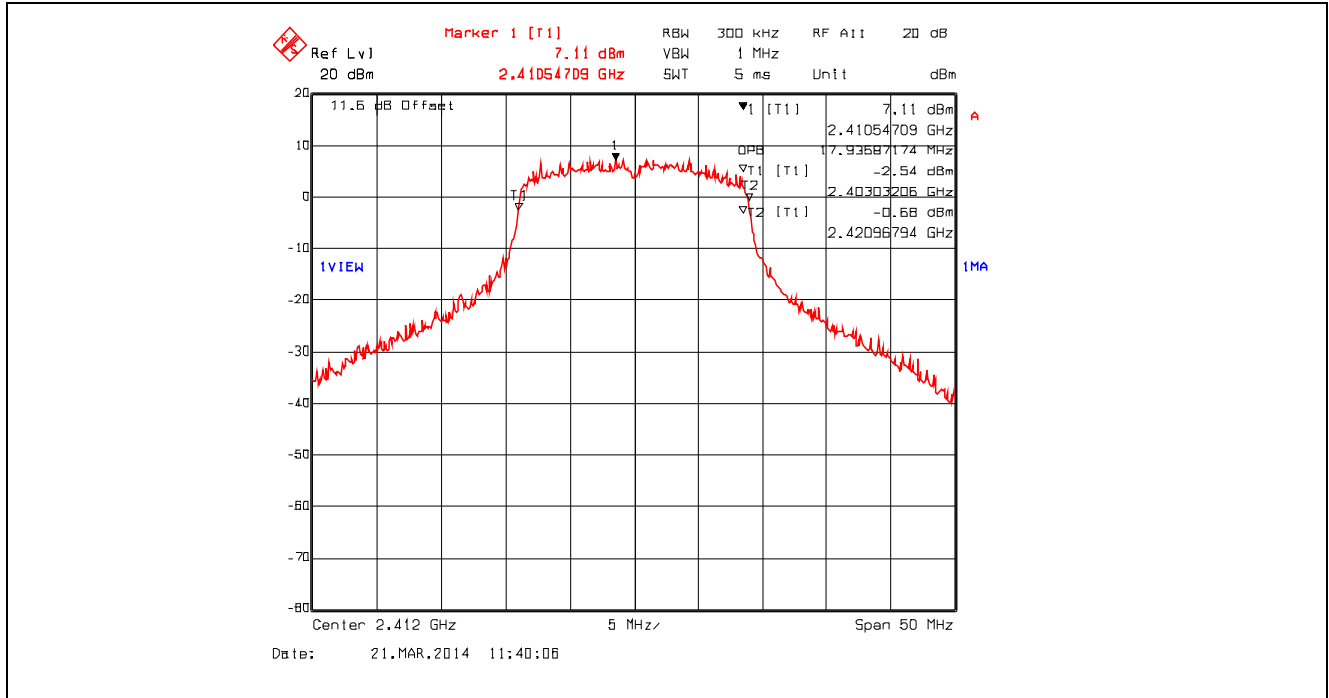

Plot 5.2.4.62. 99% Occupied Bandwidth, 802.11n 800ns, 39 Mbps 16-QAM 3/4, 2437 MHz

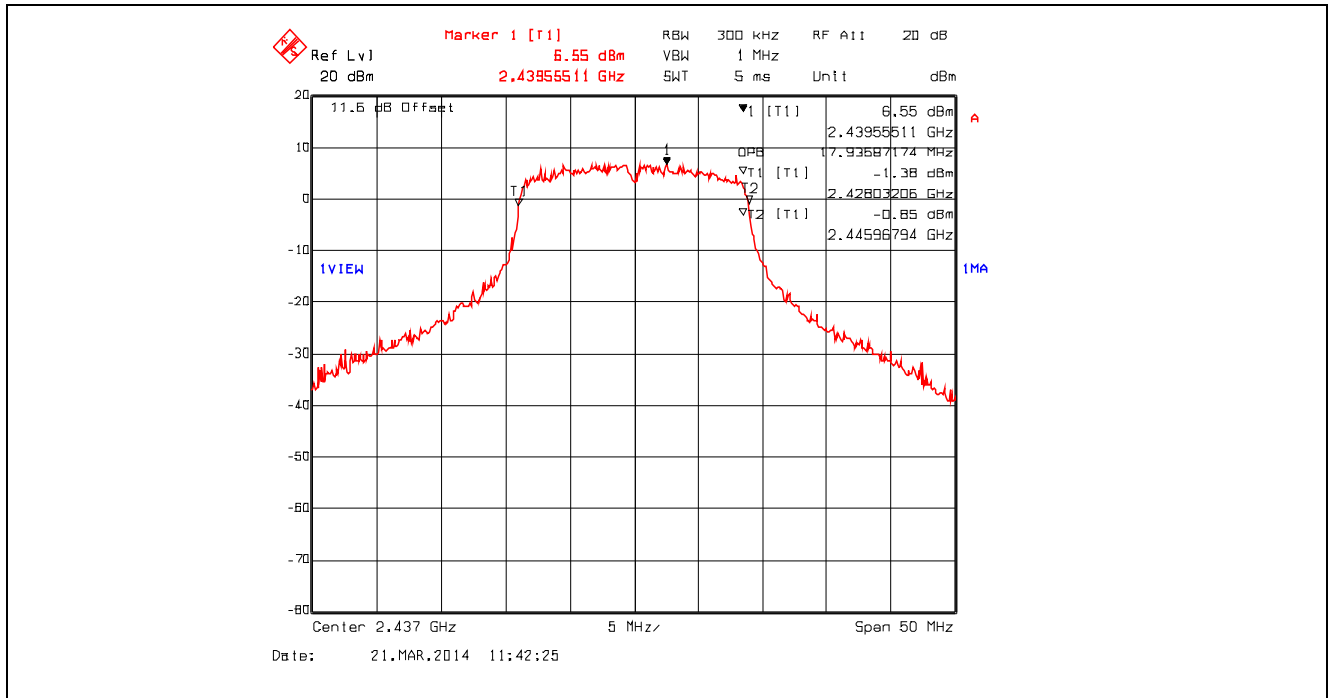

Plot 5.2.4.63. 99% Occupied Bandwidth, 802.11n 800ns, 39 Mbps 16-QAM 3/4, 2462 MHz

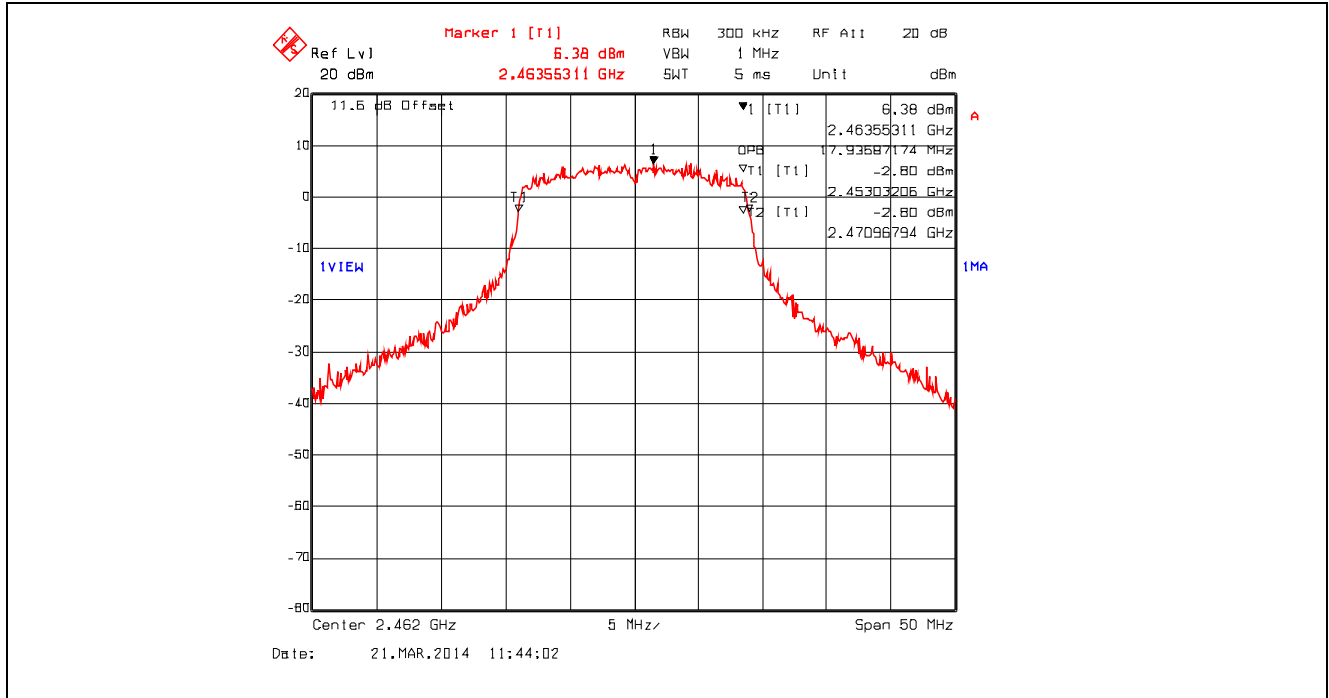

Plot 5.2.4.64. 99% Occupied Bandwidth, 802.11n 800ns, 65 Mbps 64-QAM 5/6, 2412 MHz

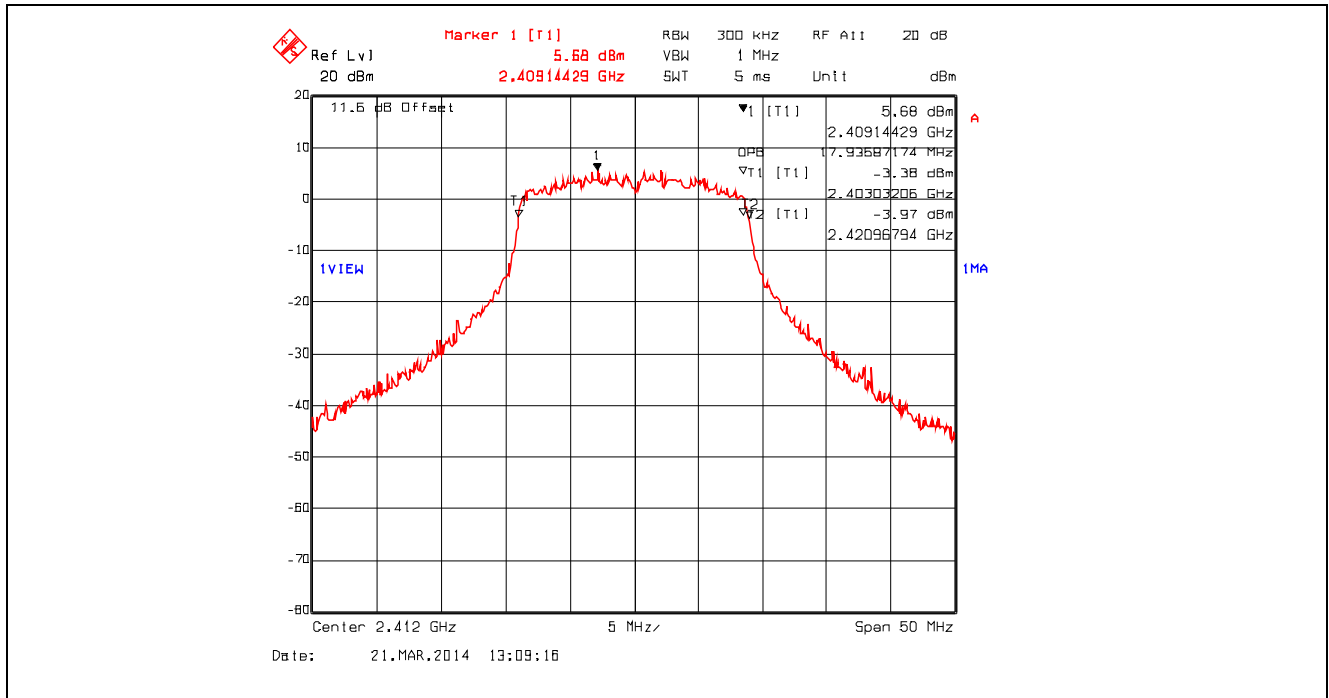

Plot 5.2.4.65. 99% Occupied Bandwidth, 802.11n 800ns, 65 Mbps 64-QAM 5/6, 2437 MHz

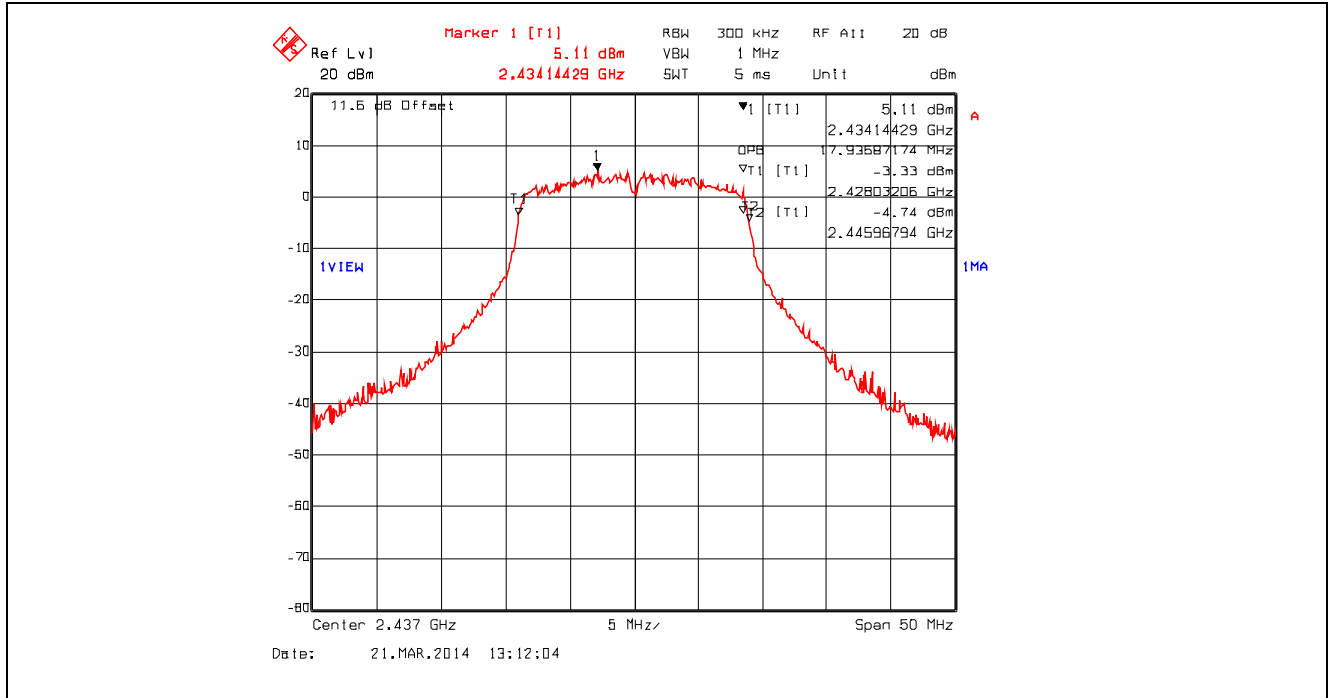

Plot 5.2.4.66. 99% Occupied Bandwidth, 802.11n 800ns, 65 Mbps 64-QAM 5/6, 2462 MHz

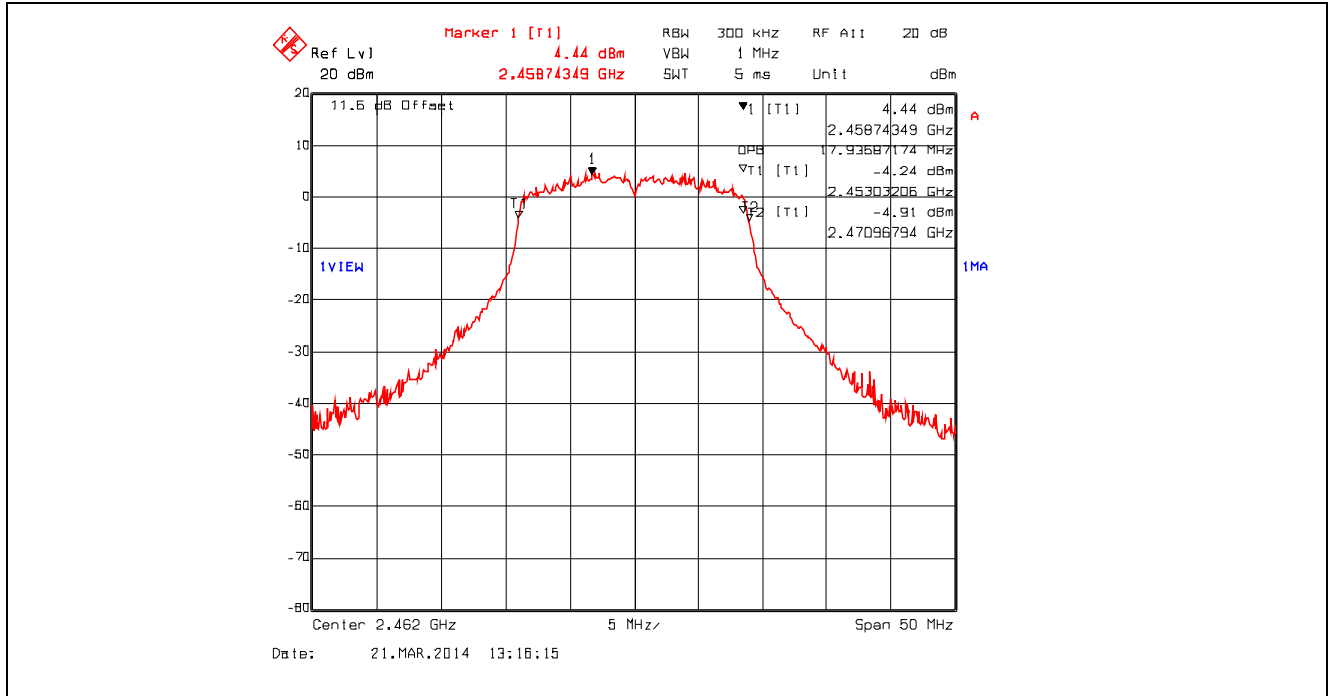

5.3. PEAK CONDUCTED OUTPUT POWER - DTS [§ 15.247(b)(3)]

5.3.1. Limit(s)

§ 15.247(b)(3): For systems using digital modulation in the 902-928 MHz, 2400-2483.5 MHz, and 5725-5850 MHz bands: 1 Watt. As an alternative to a peak power measurement, compliance with the one Watt limit can be based on a measurement of the maximum conducted output power. Maximum Conducted Output Power is defined as the total transmit power delivered to all antennas and antenna elements averaged across all symbols in the signaling alphabet when the transmitter is operating at its maximum power control level. Power must be summed across all antennas and antenna elements. The average must not include any time intervals during which the transmitter is off or is transmitting at a reduced power level. If multiple modes of operation are possible (e.g., alternative modulation methods), the *maximum conducted output power* is the highest total transmit power occurring in any mode.

§15.247(b)(4): The conducted output power limit specified in paragraph (b) of this section is based on the use of antennas with directional gains that do not exceed 6 dBi. Except as shown in paragraph (c) of this section, if transmitting antennas of directional gain greater than 6 dBi are used, the conducted output power from the intentional radiator shall be reduced below the stated values in paragraphs (b)(1), (b)(2), and (b)(3) of this section, as appropriate, by the amount in dB that the directional gain of the antenna exceeds 6 dBi.

5.3.2. Method of Measurements & Test Arrangement

KDB Publication No. 558074 D01 DTS Meas Guidance V03r01, 9.1.3 PKPM1 Peak power meter method.

5.3.3. Test Arrangement

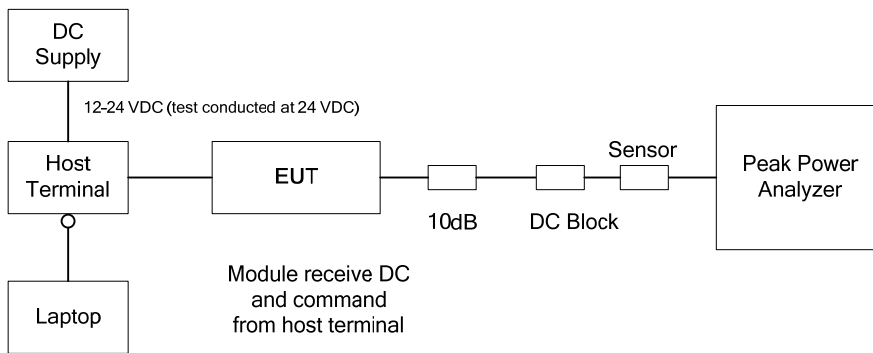

5.3.4. Test Data

Operating Mode	Modulation	Frequency (MHz)	Peak Conducted Power (dBm)	Peak Conducted Power Limit (dBm)	Margin (dBm)
802.11b	1 Mbps DBPSK	2412	22.42	30	-7.58
		2437	22.01	30	-7.99
		2462	21.75	30	-8.25
	2 Mbps DQPSK	2412	22.49	30	-7.51
		2437	22.01	30	-7.99
		2462	21.84	30	-8.16
	11 Mbps CCK	2412	22.01	30	-7.99
		2437	21.67	30	-8.33
		2462	21.40	30	-8.60
802.11g	9 Mbps BPSK	2412	23.87	30	-6.13
		2437	23.32	30	-6.68
		2462	22.73	30	-7.27
	18 Mbps QPSK	2412	23.87	30	-6.13
		2437	23.32	30	-6.68
		2462	22.65	30	-7.35
	36 Mbps 16-QAM	2412	23.81	30	-6.19
		2437	22.88	30	-7.12
		2462	22.65	30	-7.35
	54 Mbps 64-QAM	2412	23.74	30	-6.26
		2437	22.88	30	-7.12
		2462	22.65	30	-7.35
802.11n 800ns	6.5 Mbps BPSK 1/2	2412	23.87	30	-6.13
		2437	23.25	30	-6.75
		2462	22.57	30	-7.43
	19.5 Mbps QPSK 3/4	2412	23.94	30	-6.06
		2437	23.32	30	-6.68
		2462	22.73	30	-7.27
	39 Mbps 16-QAM 3/4	2412	23.87	30	-6.13
		2437	23.25	30	-6.75
		2462	22.65	30	-7.35
	65 Mbps 64-QAM 5/6	2412	23.67	30	-6.33
		2437	22.33	30	-7.67
		2462	22.09	30	-7.91
Note: The EIRP shall not exceed 36 dBm for all proposed antennas.					

5.4. TRANSMITTER BAND-EDGE & SPURIOUS CONDUCTED EMISSIONS [§ 15.247(d)]

5.4.1. Limit(s)

§ 15.247 (d): In any 100 kHz bandwidth outside the frequency band in which the spread spectrum or digitally modulated intentional radiator is operating, the radio frequency power that is produced by the intentional radiator shall be at least 20 dB below that in the 100 kHz bandwidth within the band that contains the highest level of the desired power, based on either an RF conducted or a radiated measurement, provided the transmitter demonstrates compliance with the peak conducted power limits. If the transmitter complies with the conducted power limits based on the use of RMS averaging over a time interval, as permitted under paragraph (b)(3) of this section, the attenuation required under this paragraph shall be 30 dB instead of 20 dB.

5.4.2. Method of Measurements

KDB Publication No. 558074 D01 DTS Meas Guidance V03r01, Sections 11, 12 and 13.

5.4.3. Test Arrangement

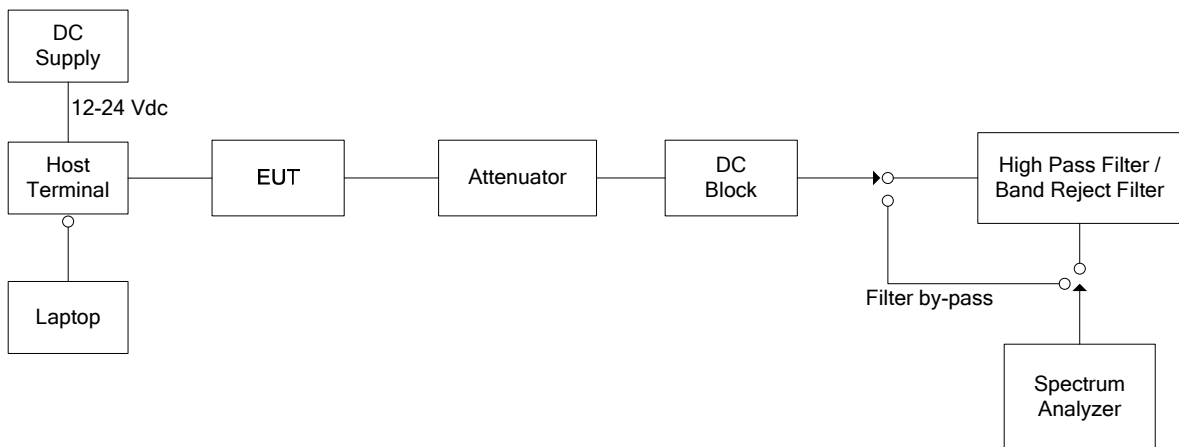

5.4.4. Test Data

5.4.4.1. Band-Edge RF Conducted Emissions

Remark: The following test results at high power setting represent the worst case, derived from exploratory tests.

Plot 5.4.4.1.1. Band-Edge RF Conducted Emissions, Lower Band-edge, 2412 MHz, 802.11b, 1 Mbps

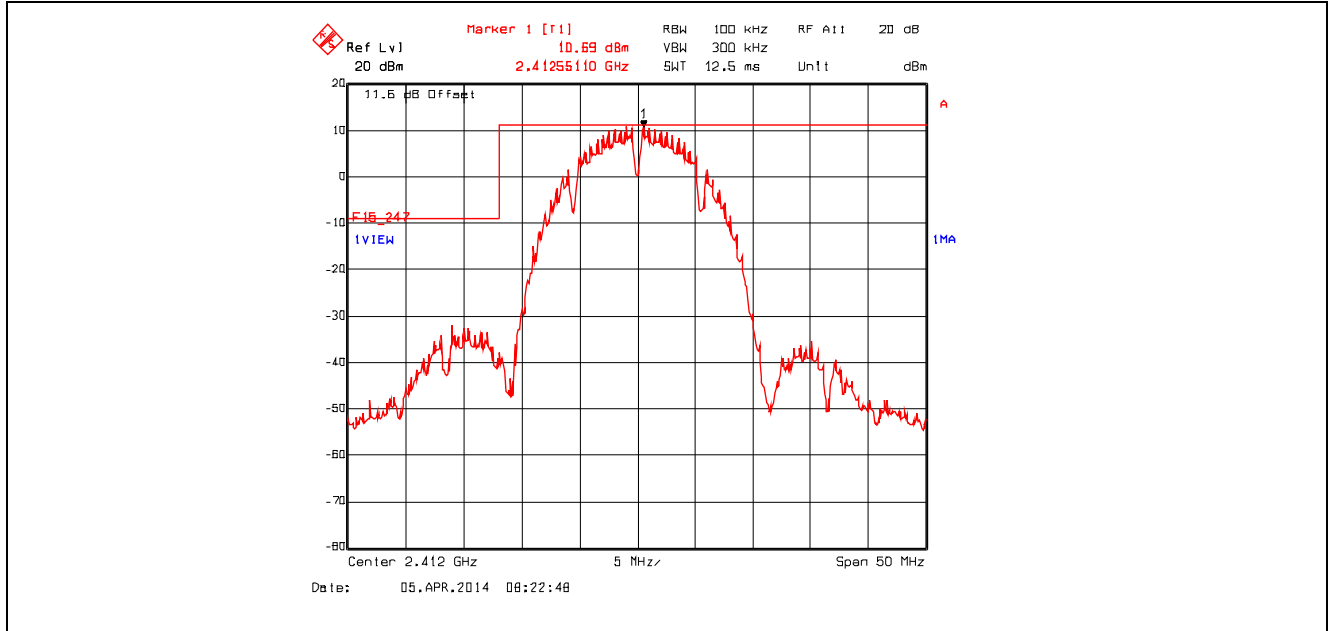

Plot 5.4.4.1.2. Band-Edge RF Conducted Emissions, Upper Band-edge, 2462 MHz, 802.11b, 1 Mbps

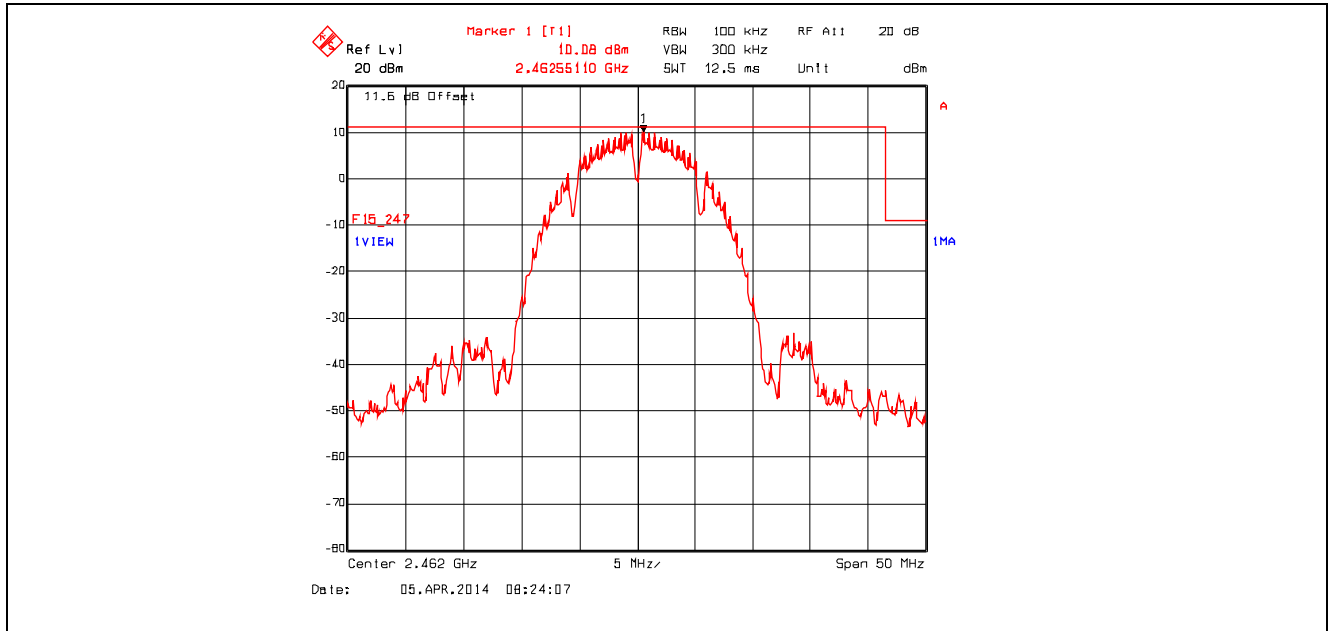

Plot 5.4.4.1.3. Band-Edge RF Conducted Emissions, Lower Band-edge, 2412 MHz, 802.11g, 54 Mbps

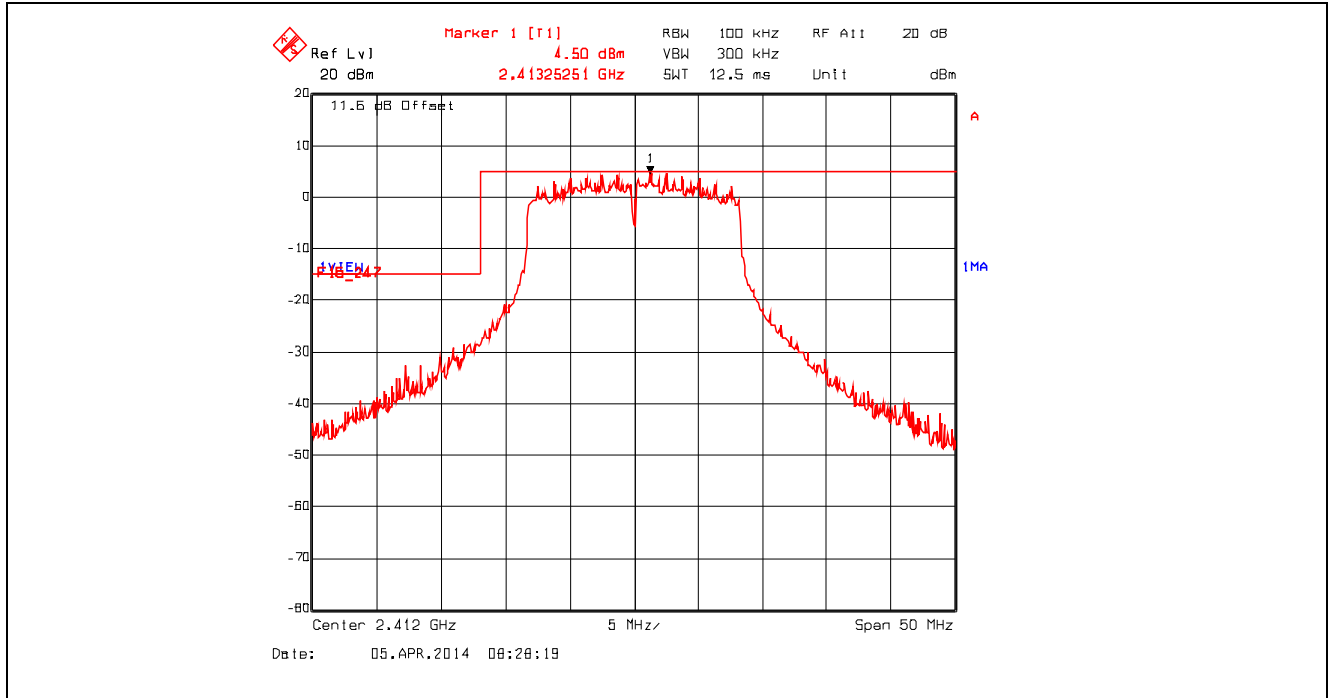

Plot 5.4.4.1.4. Band-Edge RF Conducted Emissions, Upper Band-edge, 2462 MHz, 802.11g, 54 Mbps

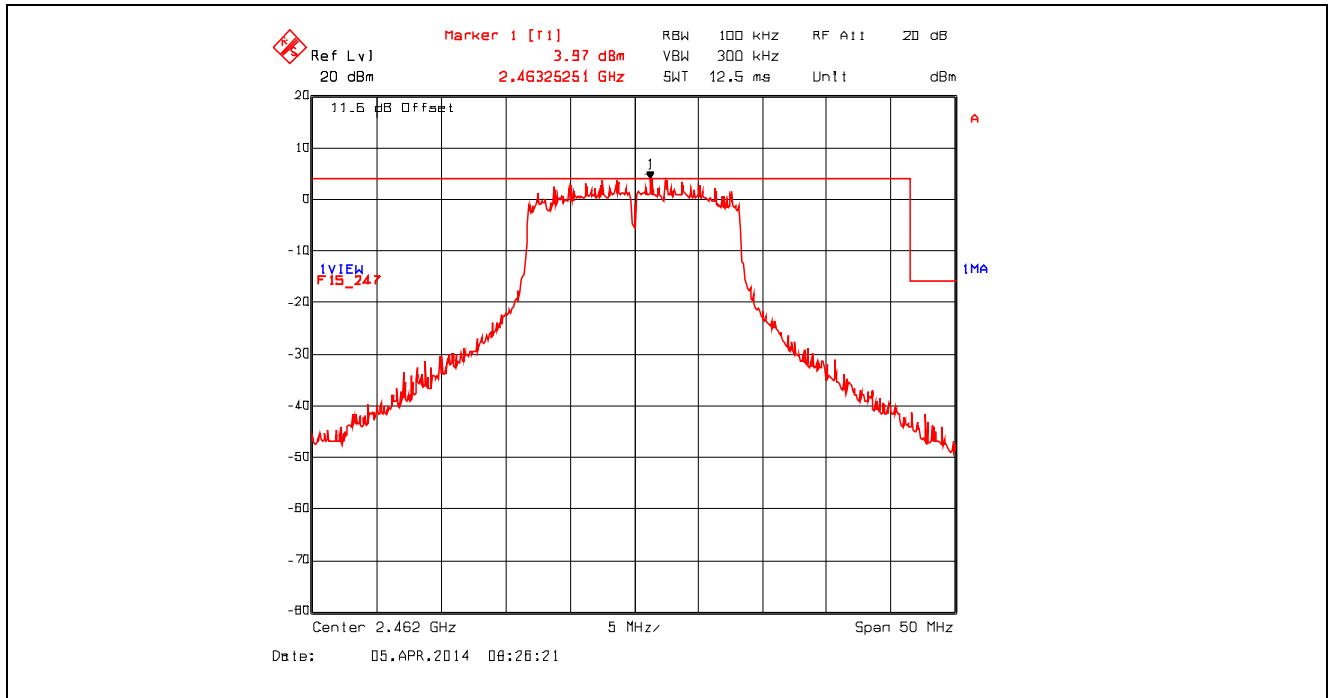

Plot 5.4.4.1.5. Band-Edge RF Conducted Emissions, Lower Band-edge, 2412 MHz, 802.11n 800ns, 65 Mbps

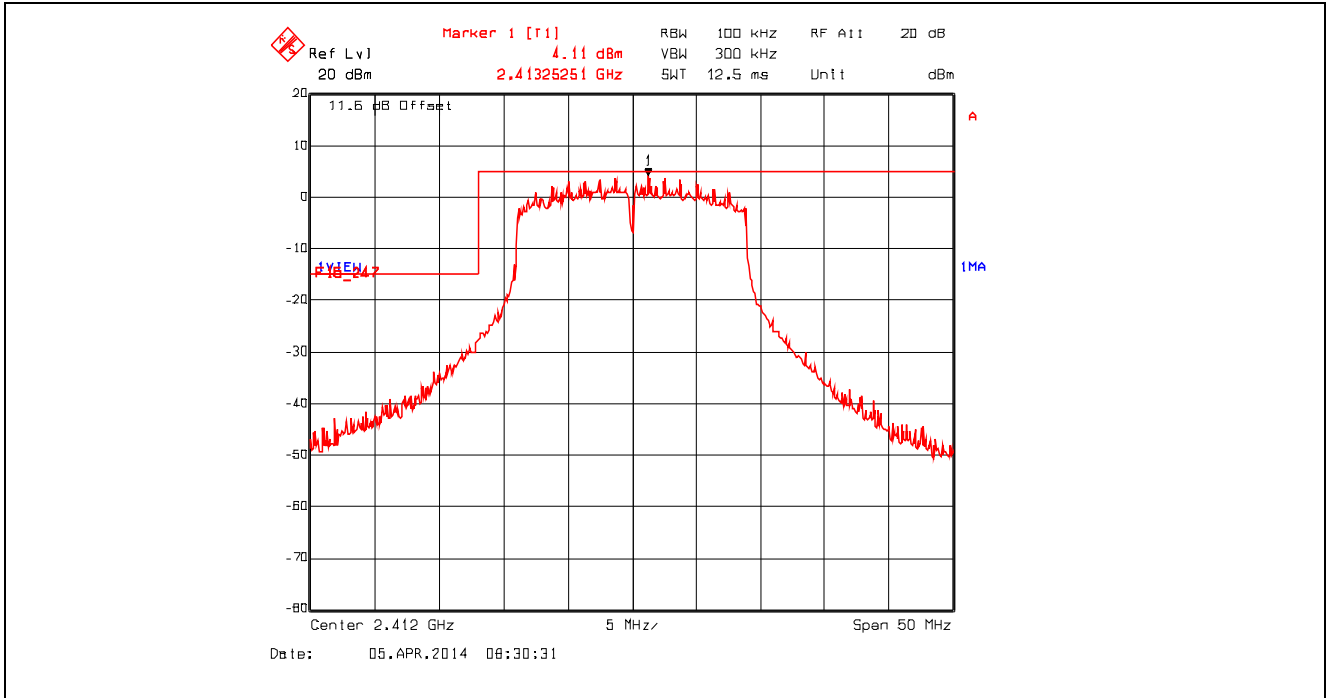

Plot 5.4.4.1.6. Band-Edge RF Conducted Emissions, Upper Band-edge, 2462 MHz, 802.11n 800ns, 65 Mbps

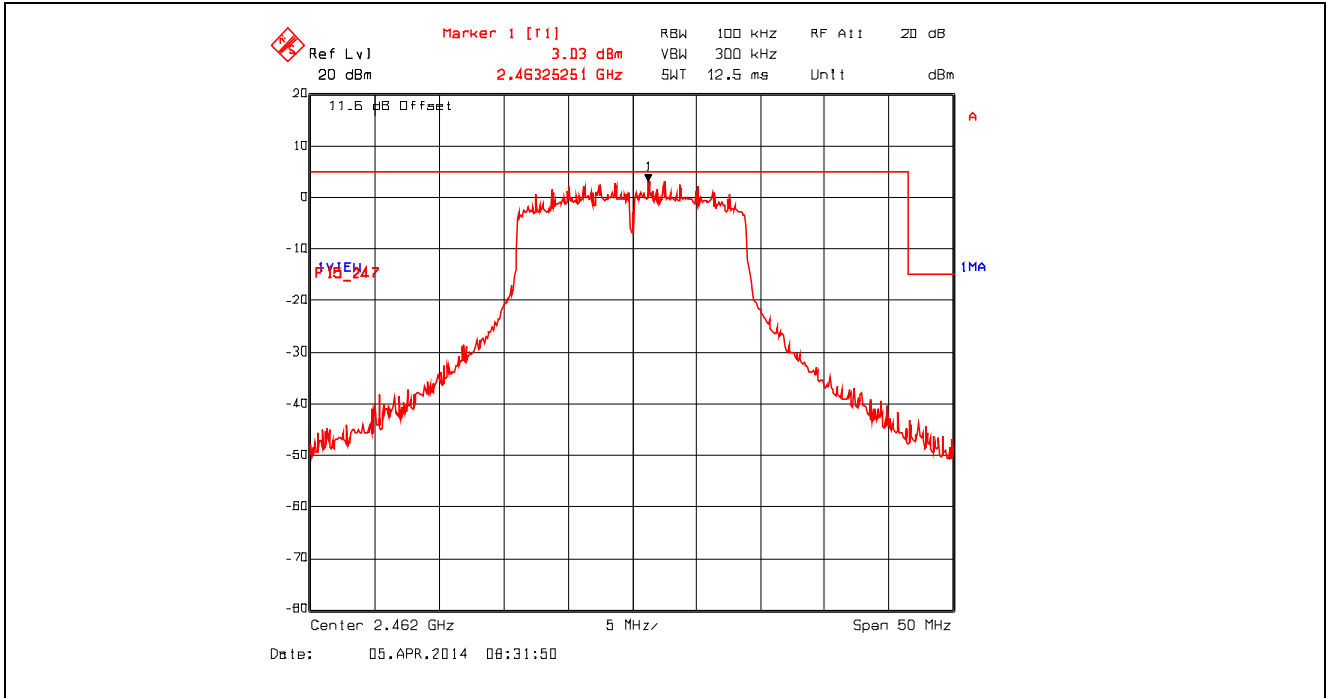

5.4.4.2. Spurious RF Conducted Emissions – Non Restricted Frequency Bands

Remark: The following test results at high power setting represent the worst case, derived from exploratory tests.

**Plot 5.4.4.2.1. Conducted Spurious Emissions - Non Restricted Frequency Bands
 802.11b, 2412 MHz, 1 Mbps, 10 MHz - 2.6 GHz**

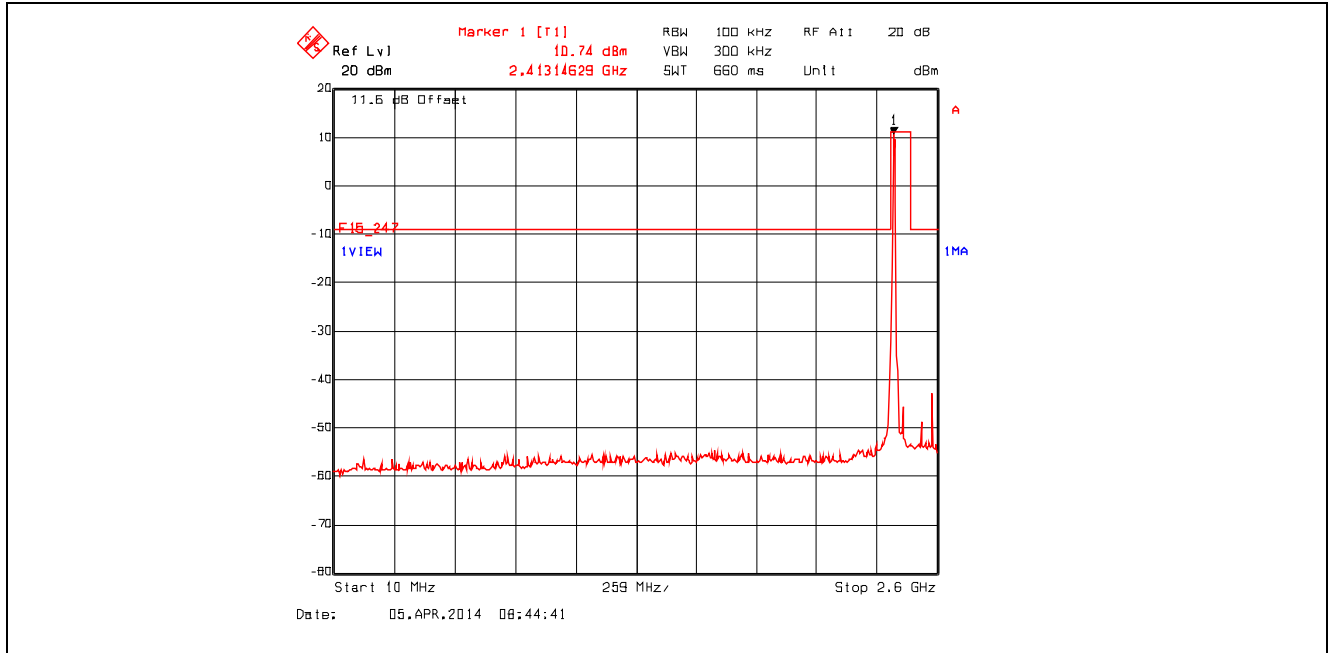

**Plot 5.4.4.2.2. Conducted Spurious Emissions - Non Restricted Frequency Bands
 802.11b, 2412 MHz, 1 Mbps, 2.6 GHz - 25 GHz**

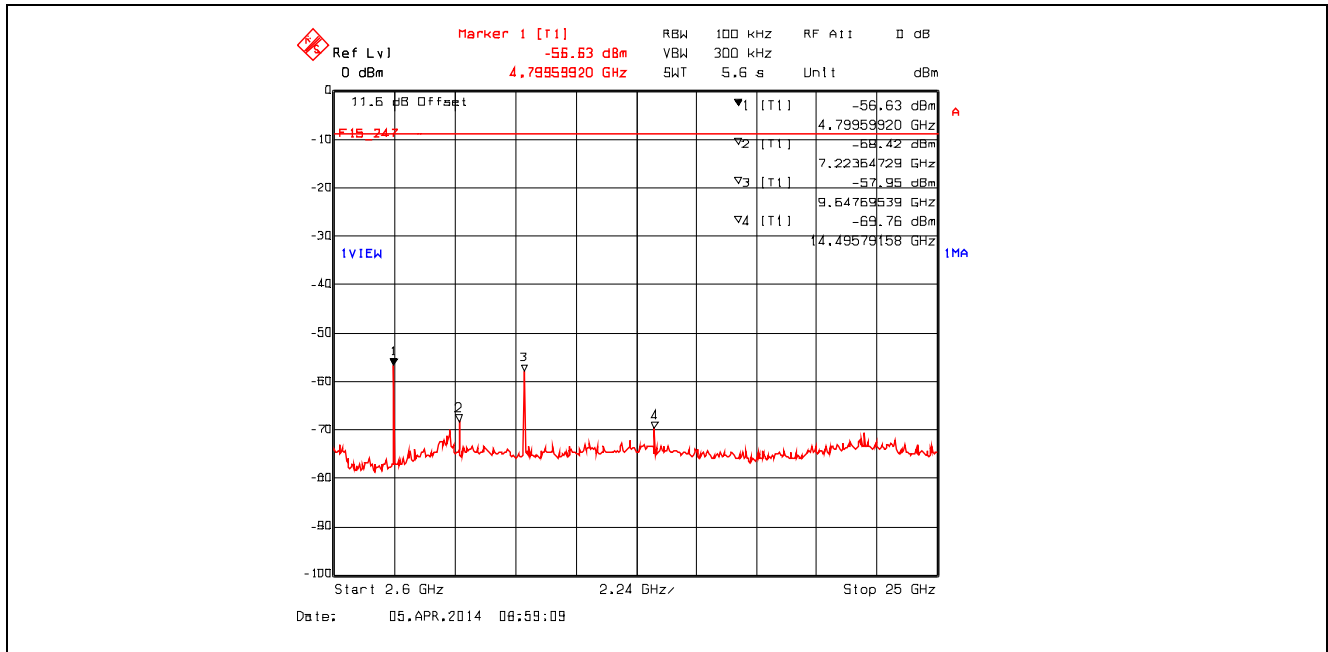

Plot 5.4.4.2.3. Conducted Spurious Emissions - Non Restricted Frequency Bands
 802.11b, 2437 MHz, 1 Mbps, 10 MHz - 2.6 GHz

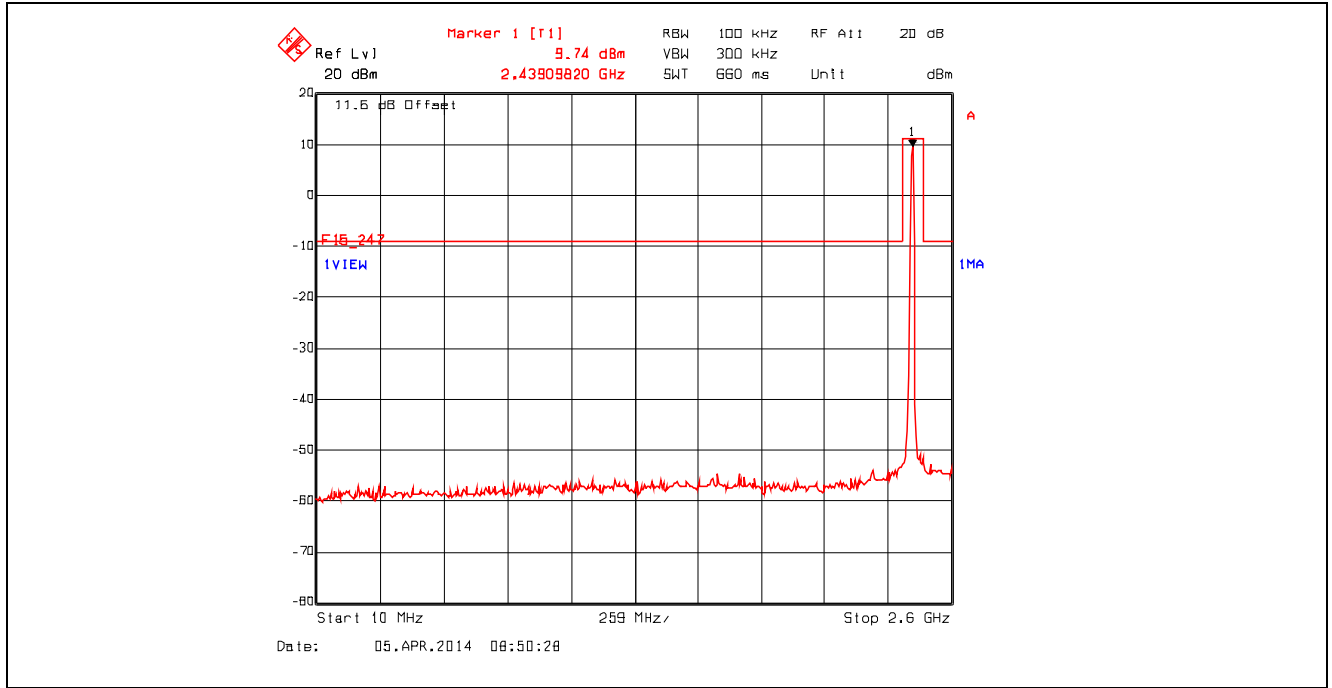

Plot 5.4.4.2.4. Conducted Spurious Emissions - Non Restricted Frequency Bands
 802.11b, 2437 MHz, 1 Mbps, 2.6 GHz - 25 GHz

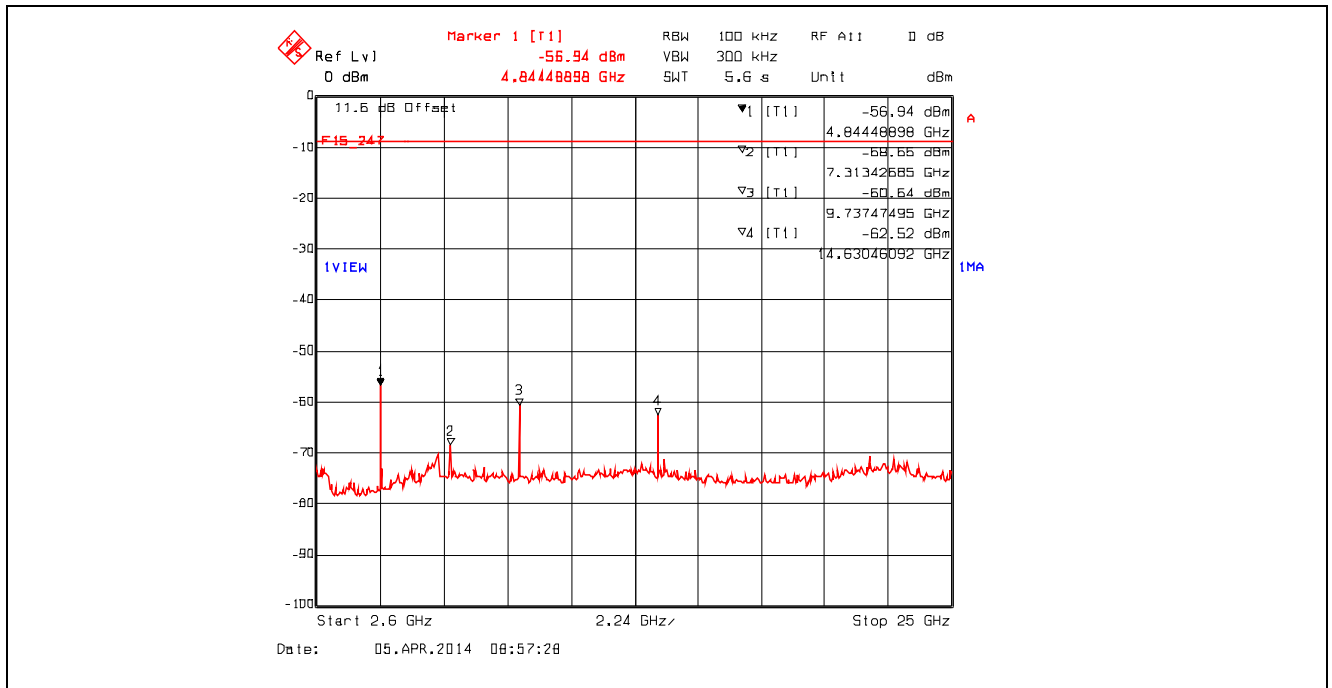

**Plot 5.4.4.2.5. Conducted Spurious Emissions - Non Restricted Frequency Bands
 802.11b, 2462 MHz, 1 Mbps, 10 MHz - 2.6 GHz**

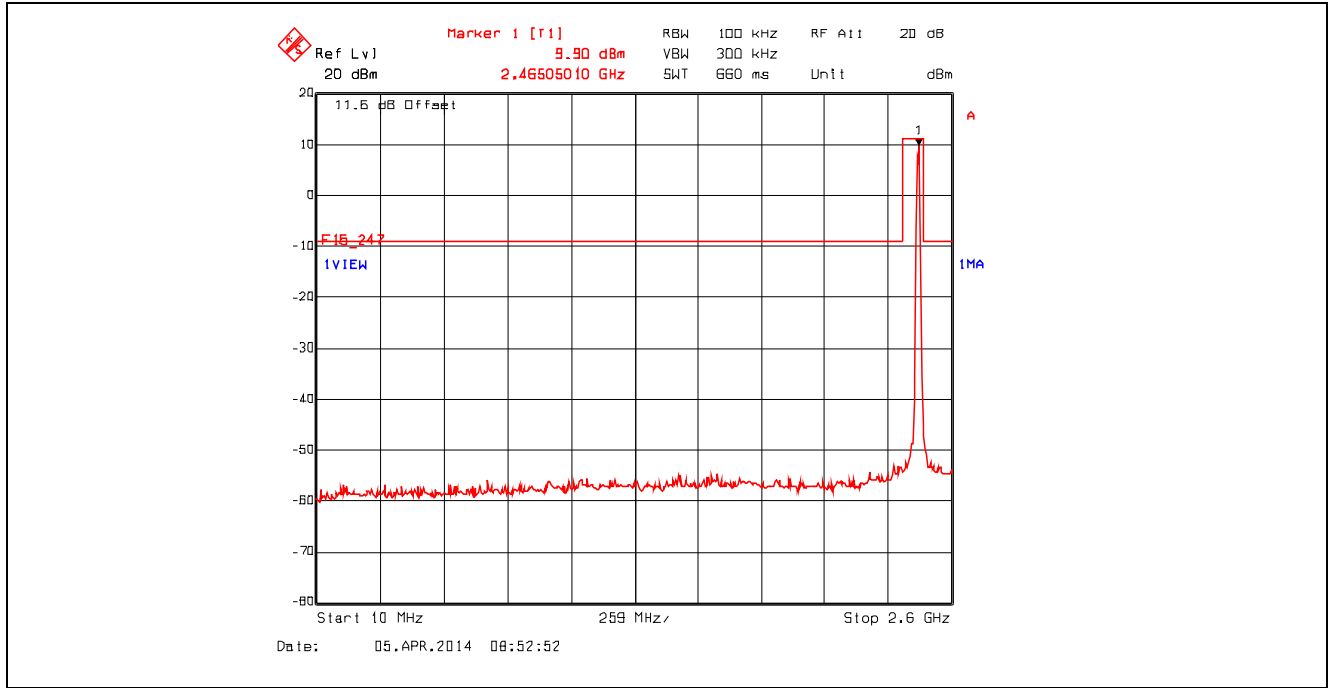

**Plot 5.4.4.2.6. Conducted Spurious Emissions - Non Restricted Frequency Bands
 802.11b, 2462 MHz, 1 Mbps, 2.6 GHz - 25 GHz**

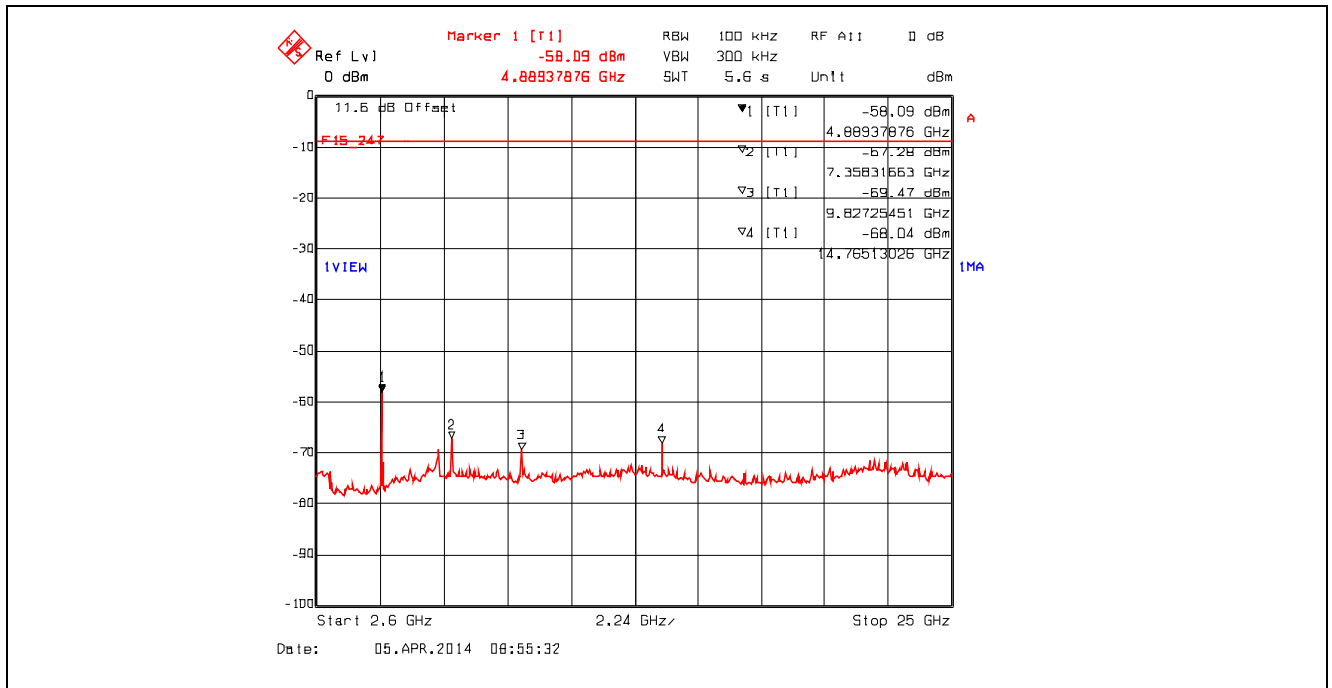

**Plot 5.4.4.2.7. Conducted Spurious Emissions - Non Restricted Frequency Bands
 802.11g, 2412 MHz, 9 Mbps, 10 MHz - 2.6 GHz**

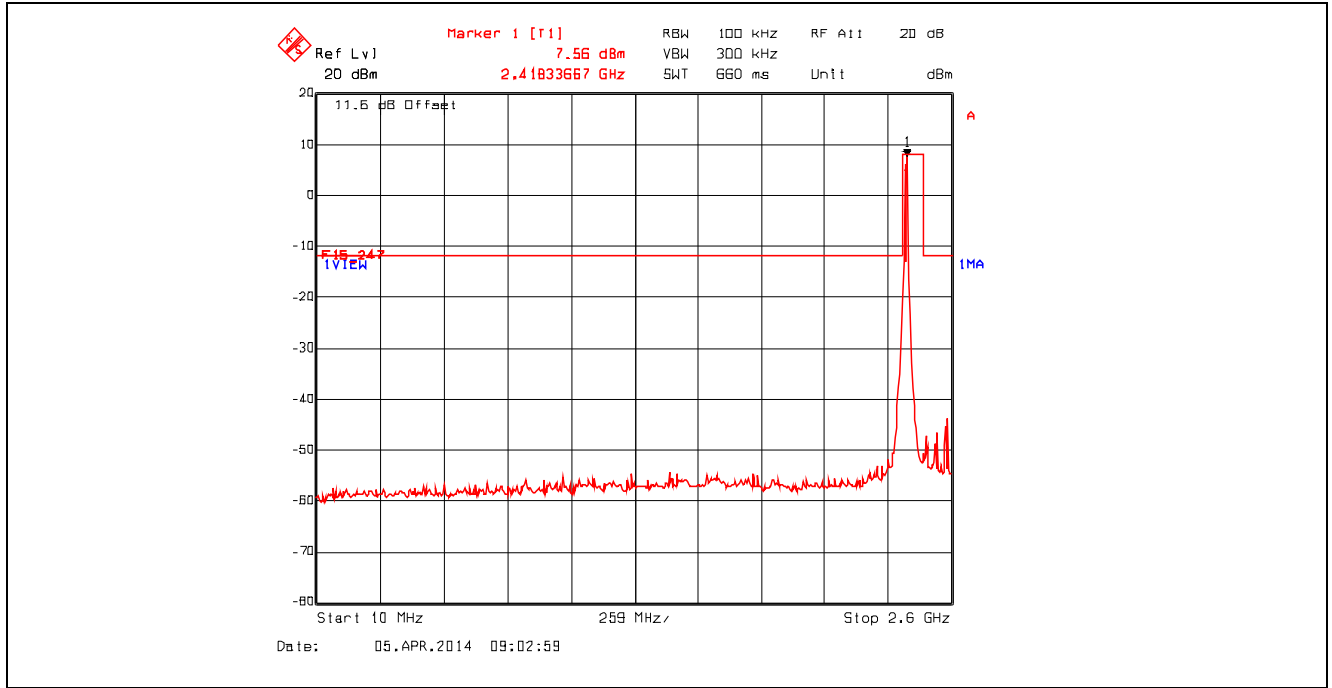

**Plot 5.4.4.2.8. Conducted Spurious Emissions - Non Restricted Frequency Bands
 802.11g, 2412 MHz, 9 Mbps, 2.6 GHz - 25 GHz**

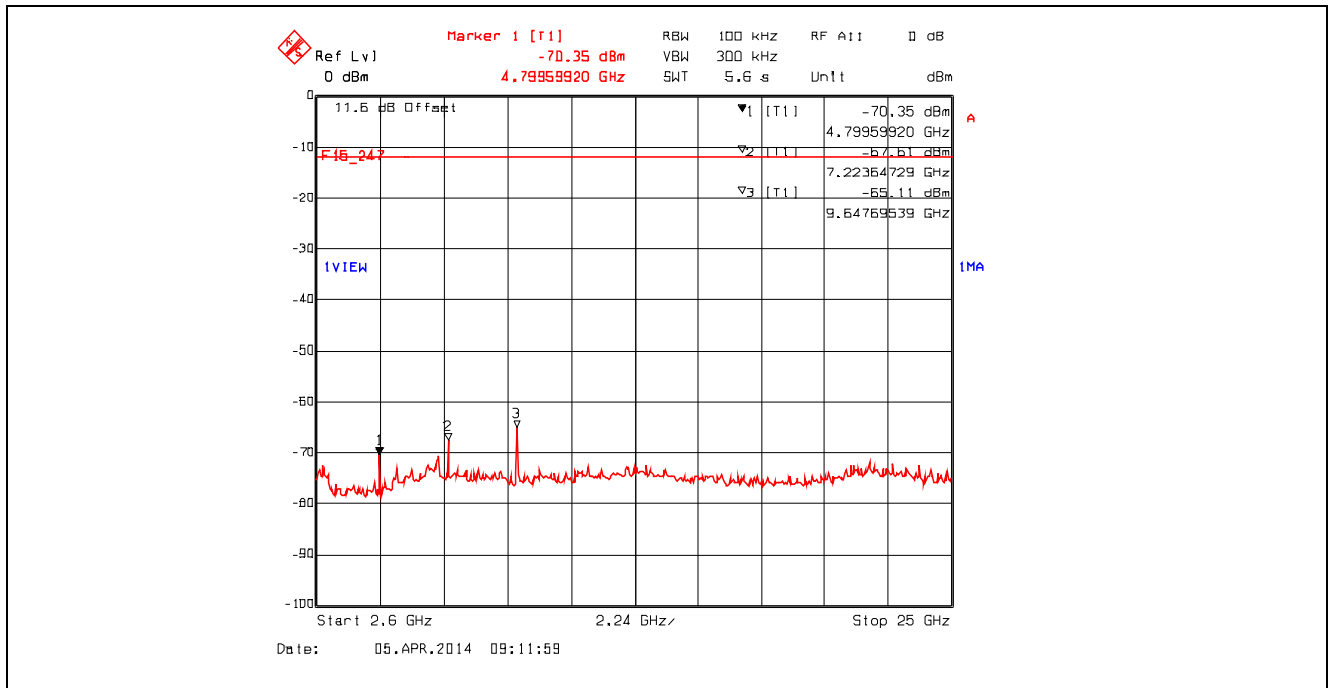

Plot 5.4.4.2.9. Conducted Spurious Emissions - Non Restricted Frequency Bands
 802.11g, 2437 MHz, 9 Mbps, 10 MHz - 2.6 GHz

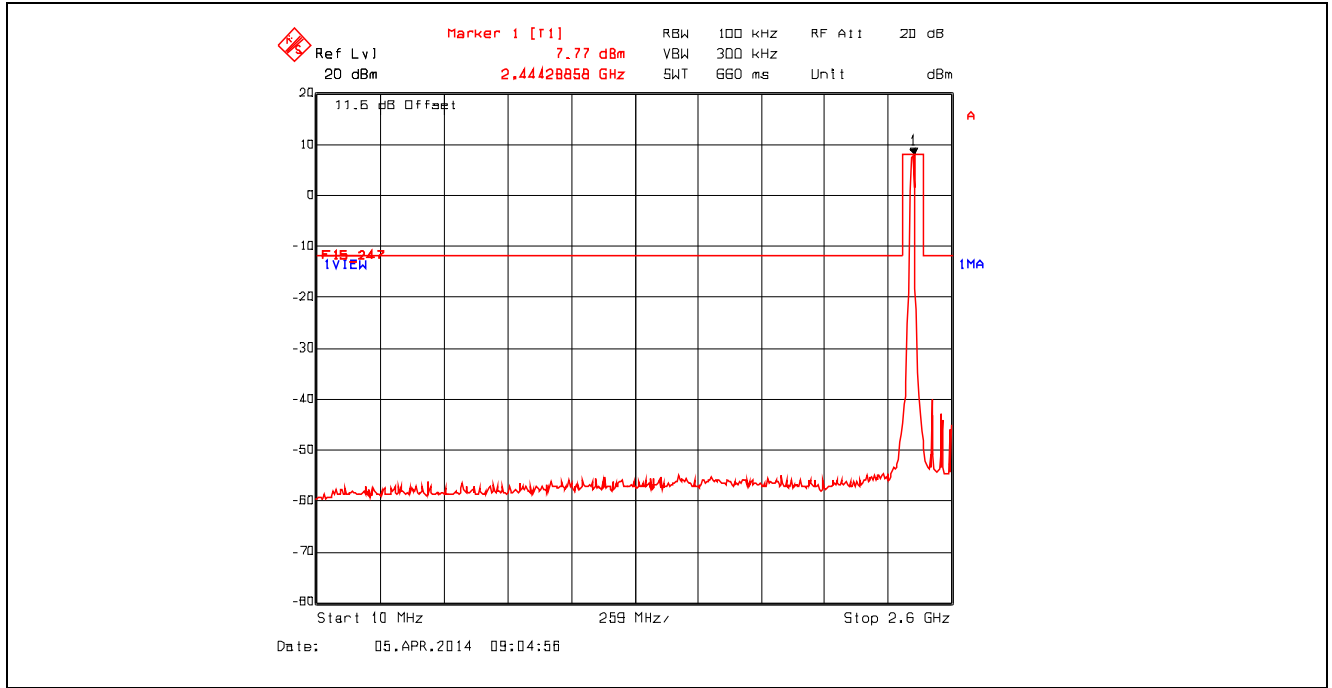

Plot 5.4.4.2.10. Conducted Spurious Emissions - Non Restricted Frequency Bands
 802.11g, 2437 MHz, 9 Mbps, 2.6 GHz - 25 GHz

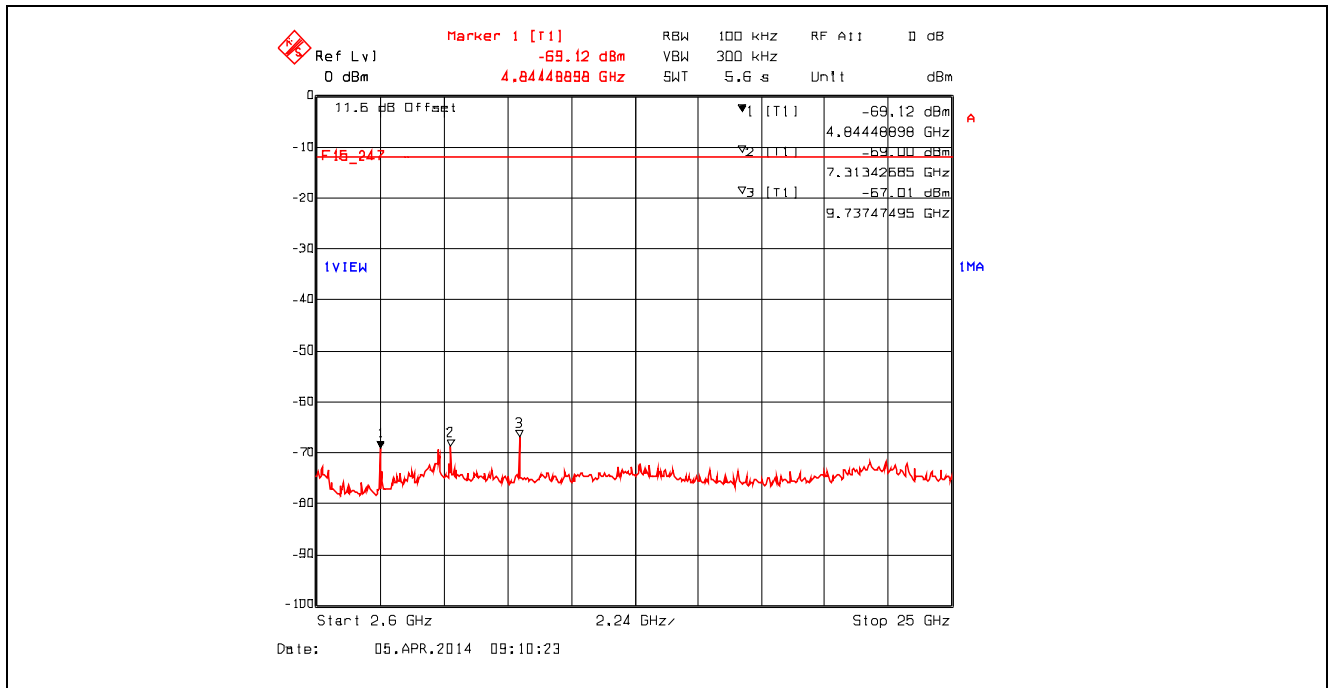

Plot 5.4.4.2.11. Conducted Spurious Emissions - Non Restricted Frequency Bands
 802.11g, 2462 MHz, 9 Mbps, 10 MHz - 2.6 GHz

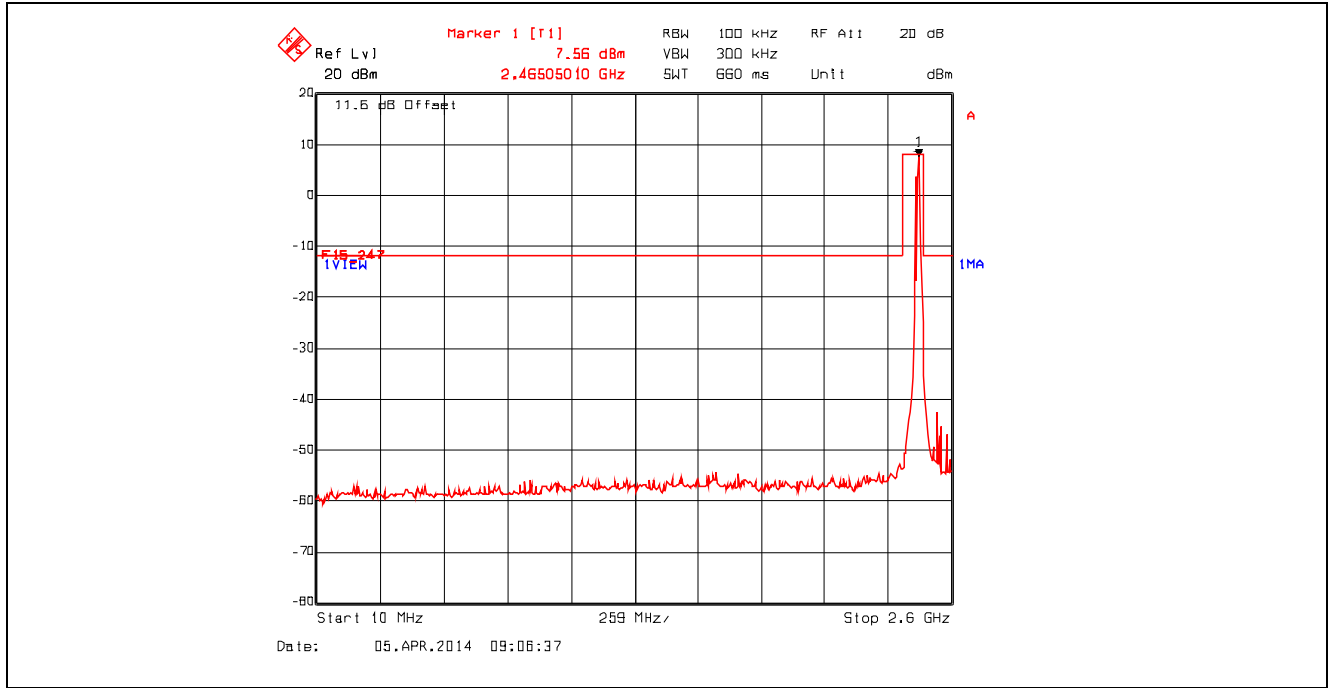

Plot 5.4.4.2.12. Conducted Spurious Emissions - Non Restricted Frequency Bands
 802.11g, 2462 MHz, 9 Mbps, 2.6 GHz - 25 GHz

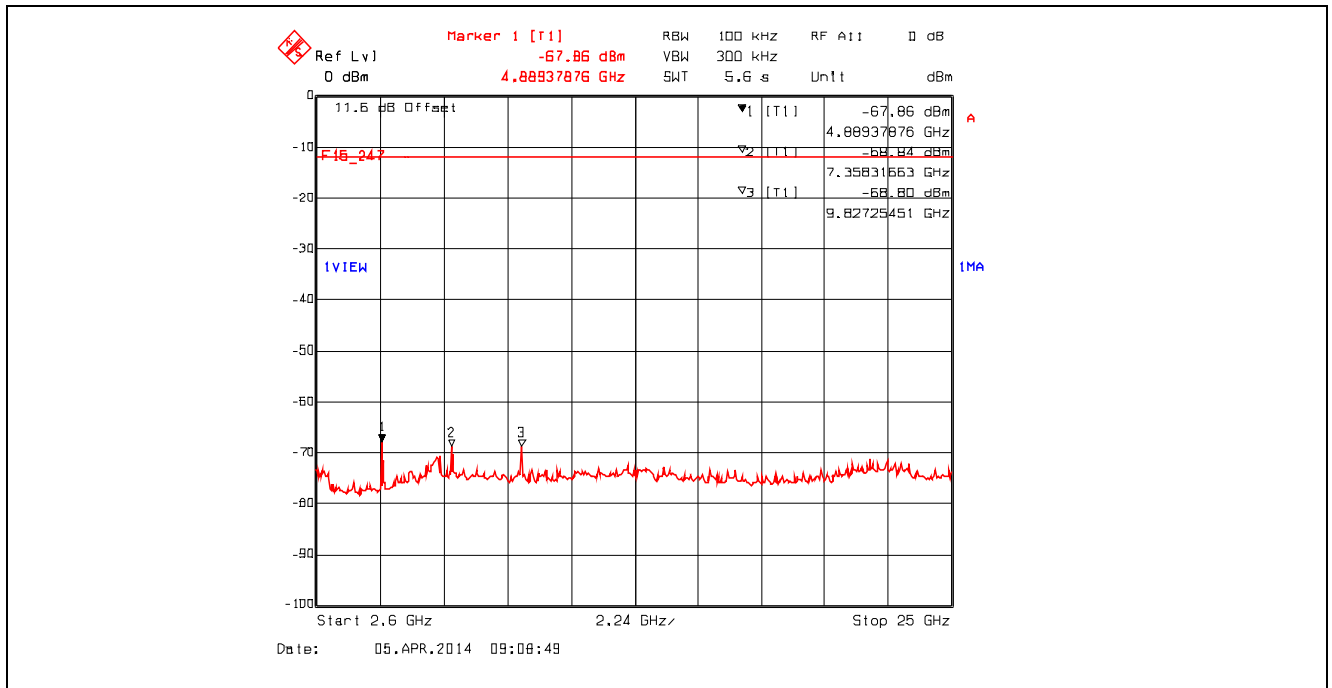

Plot 5.4.4.2.13. Conducted Spurious Emissions - Non Restricted Frequency Bands
 802.11n, 2412 MHz, 6.5 Mbps, 10 MHz - 2.6 GHz

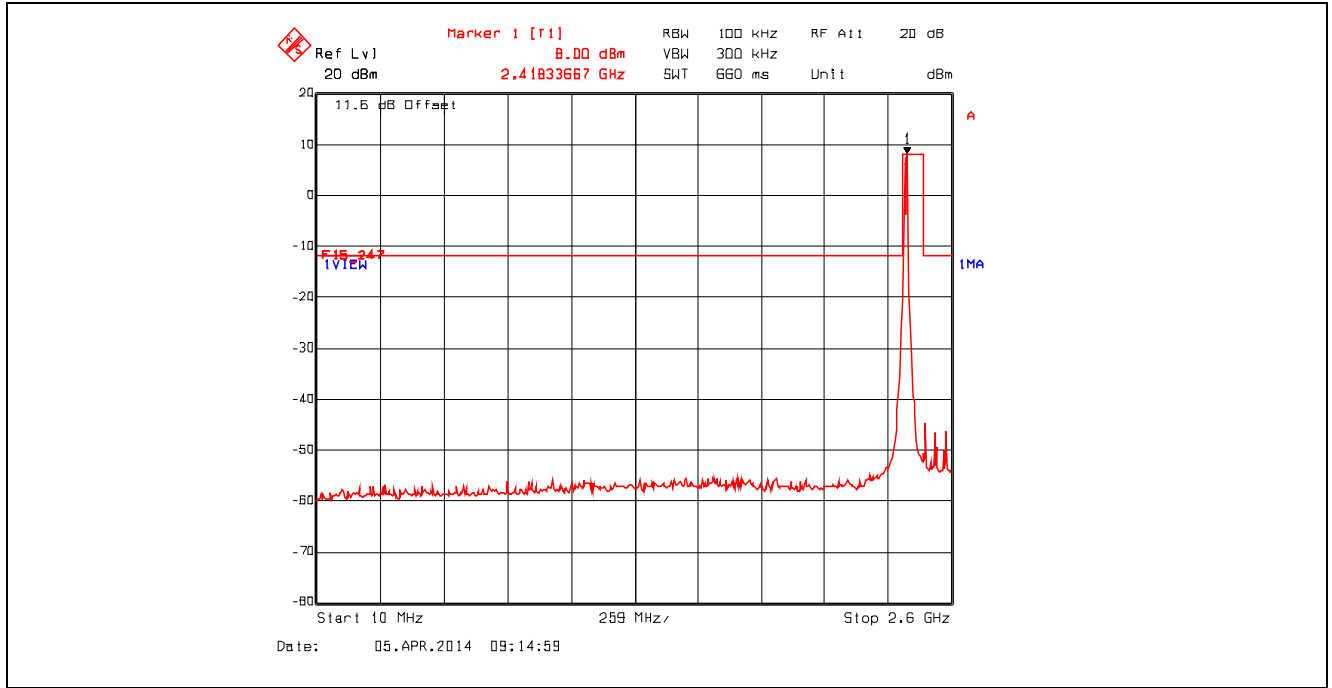

Plot 5.4.4.2.14. Conducted Spurious Emissions - Non Restricted Frequency Bands
 802.11n, 2412 MHz, 6.5 Mbps, 2.6 GHz - 25 GHz

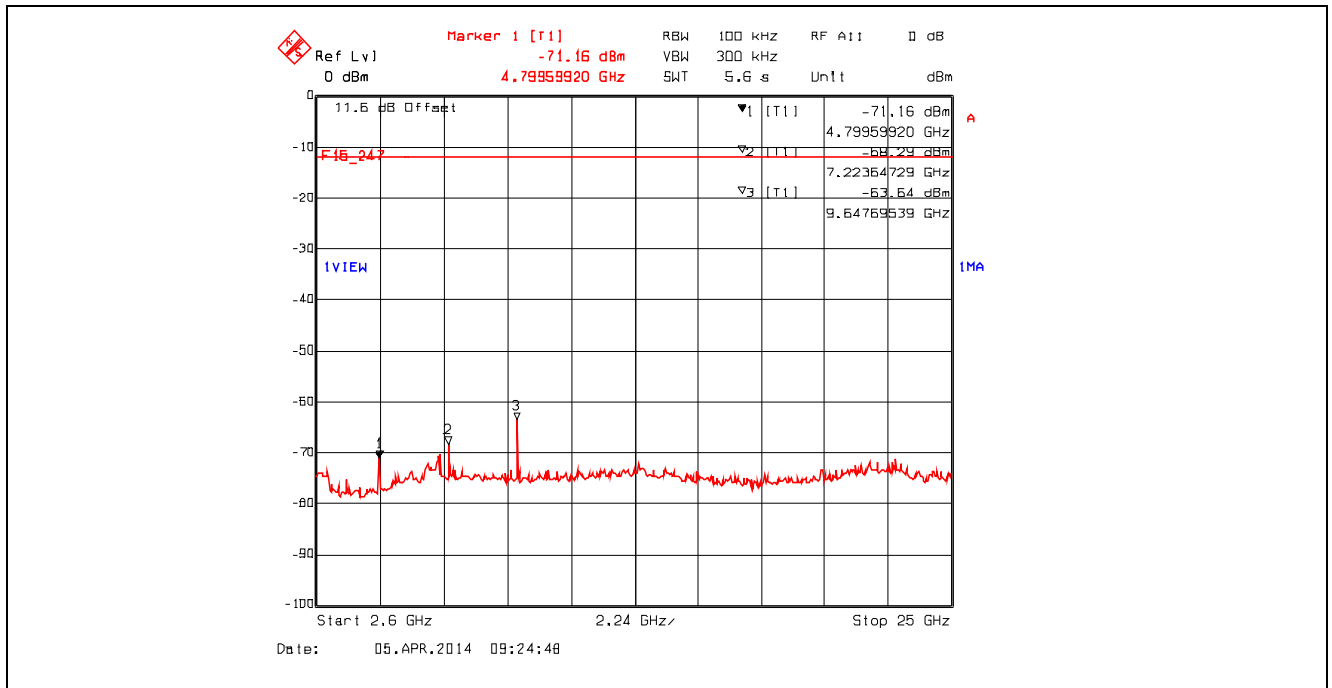

Plot 5.4.4.2.15. Conducted Spurious Emissions - Non Restricted Frequency Bands
 802.11n, 2437 MHz, 6.5 Mbps, 10 MHz - 2.6 GHz

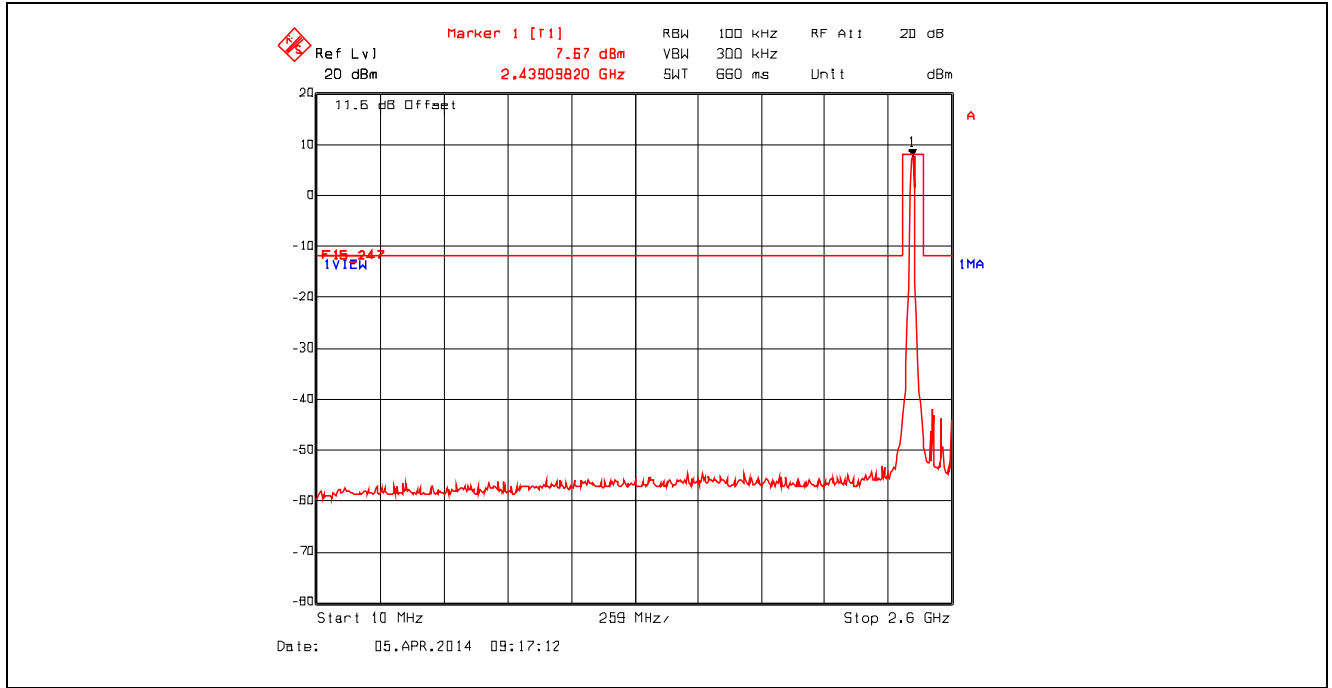

Plot 5.4.4.2.16. Conducted Spurious Emissions - Non Restricted Frequency Bands
 802.11n, 2437 MHz, 6.5 Mbps, 2.6 GHz - 25 GHz

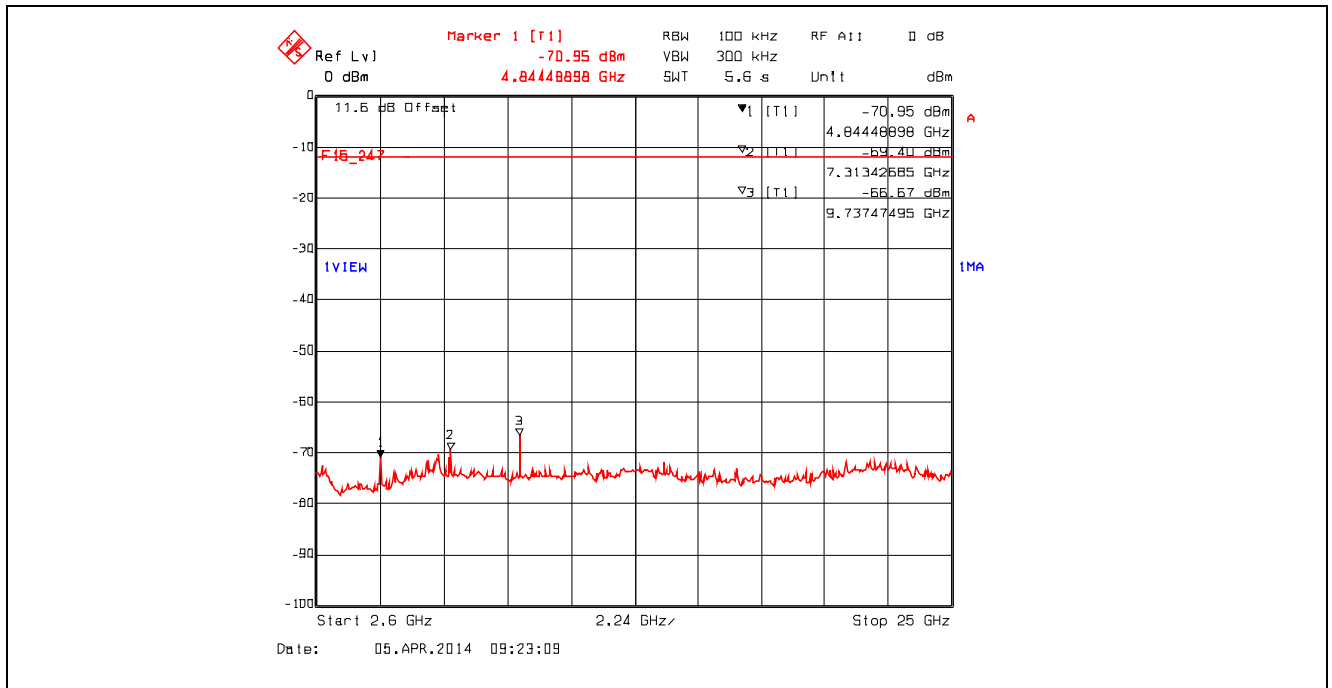

Plot 5.4.4.2.17. Conducted Spurious Emissions - Non Restricted Frequency Bands
 802.11n, 2462 MHz, 6.5 Mbps, 10 MHz - 2.6 GHz

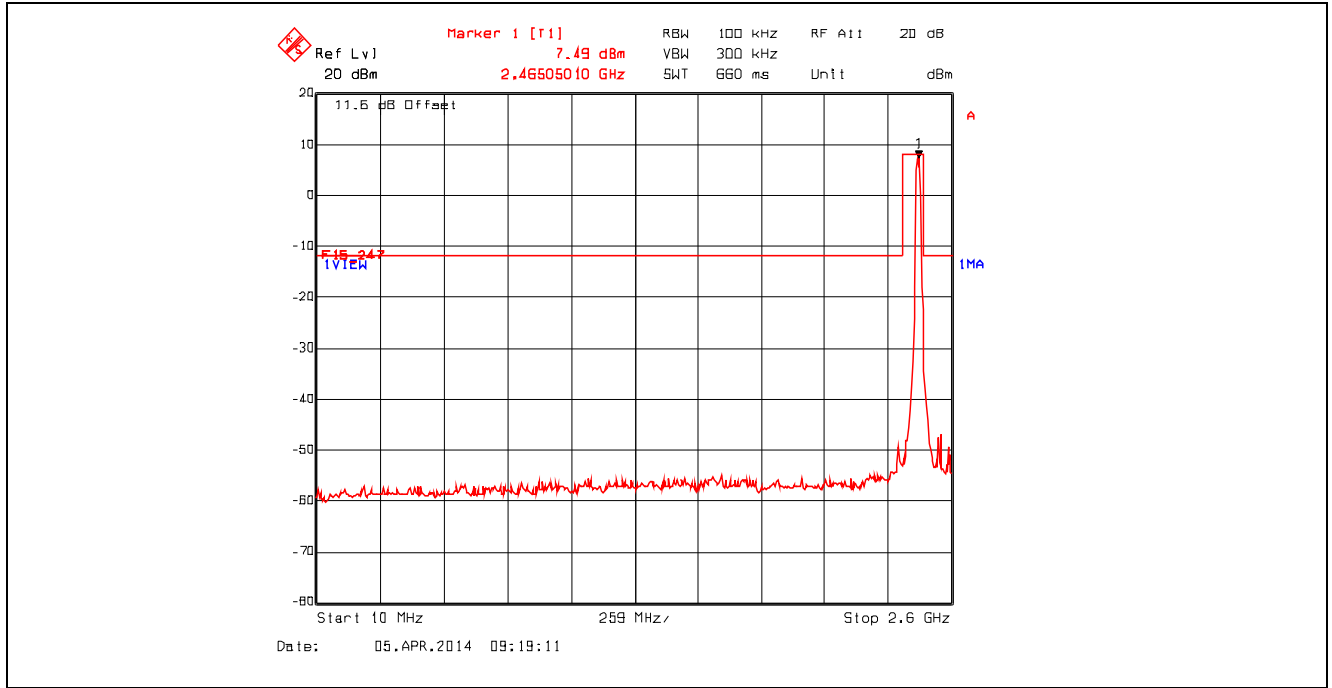

Plot 5.4.4.2.18. Conducted Spurious Emissions - Non Restricted Frequency Bands
 802.11n, 2462 MHz, 6.5 Mbps, 2.6 GHz - 25 GHz

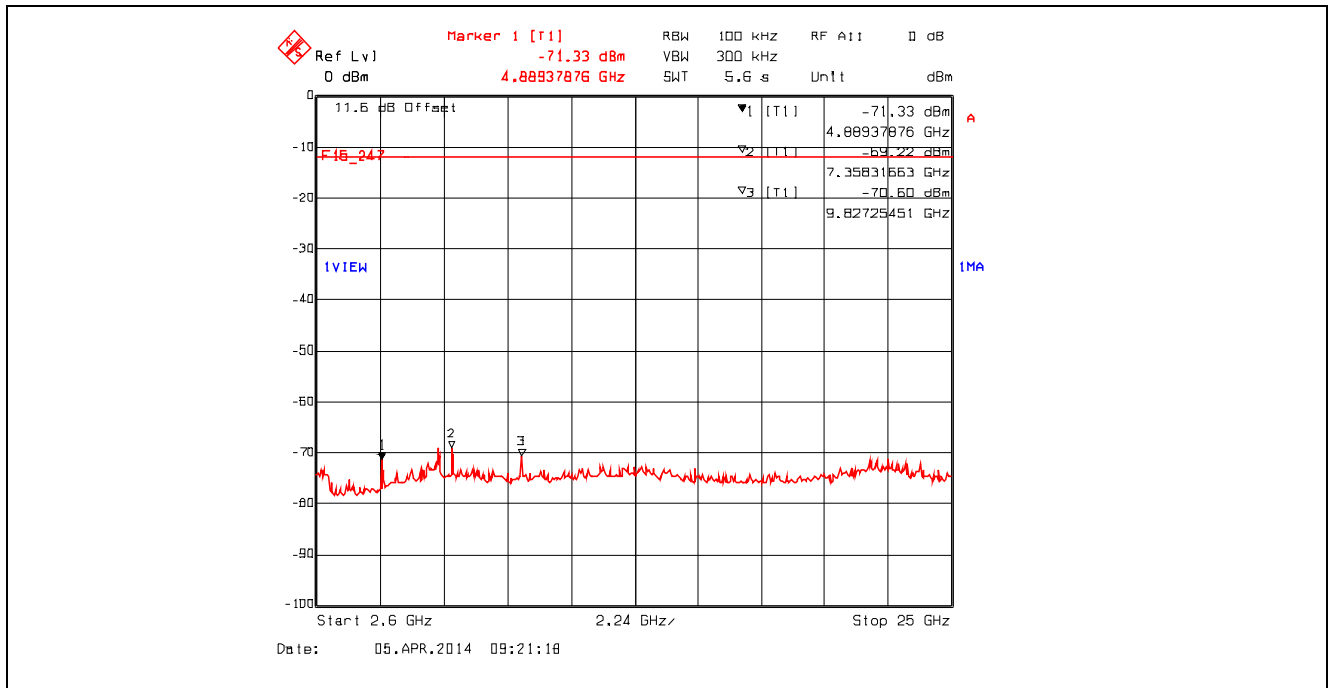

5.4.4.3. Conducted Spurious Emissions – Restricted Bands

Remark(s): Offset: Insertion Loss (11.64 dB) + Highest Antenna Gain (2 dBi) = 13.64 dB

Plot 5.4.4.3.1. Conducted Spurious Emissions – Restricted Bands
 802.11b, 1 Mbps, 2412 MHz, 9 kHz - 150 kHz, Peak Detector with Band (Notch) Reject Filter

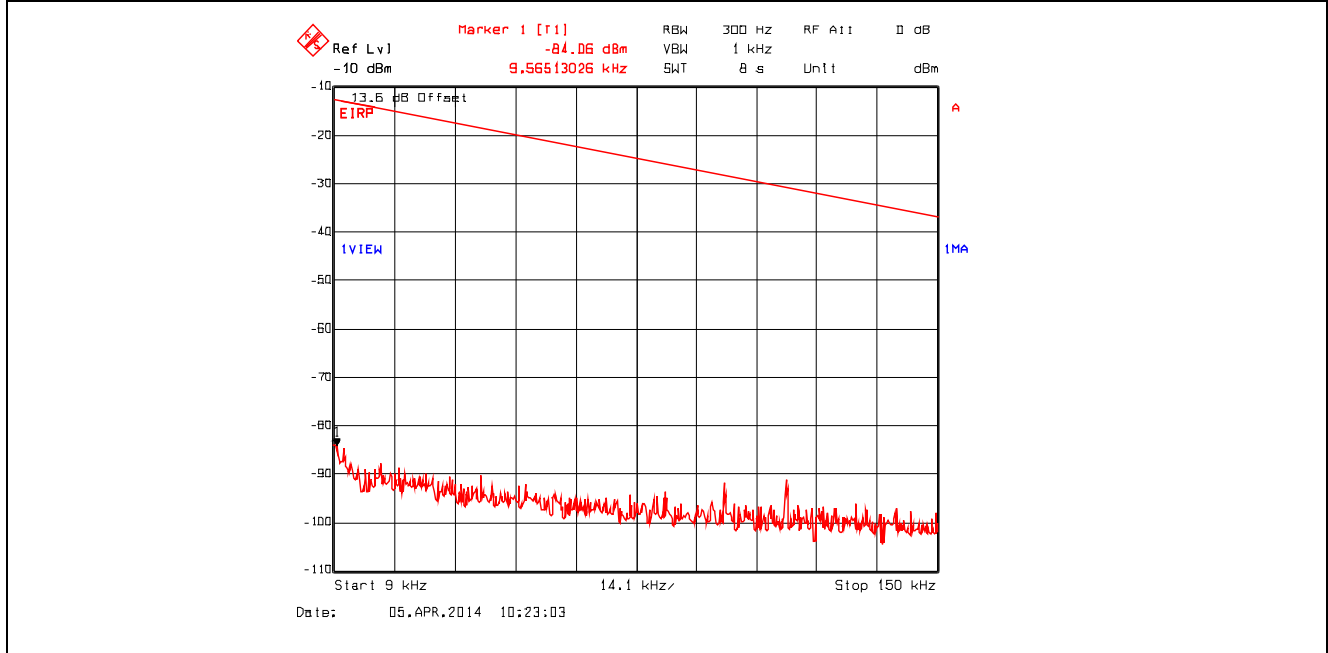

Plot 5.4.4.3.2. Conducted Spurious Emissions – Restricted Bands
 802.11b, 1 Mbps, 2412 MHz, 150 kHz - 30 MHz, Peak Detector with Band (Notch) Reject Filter

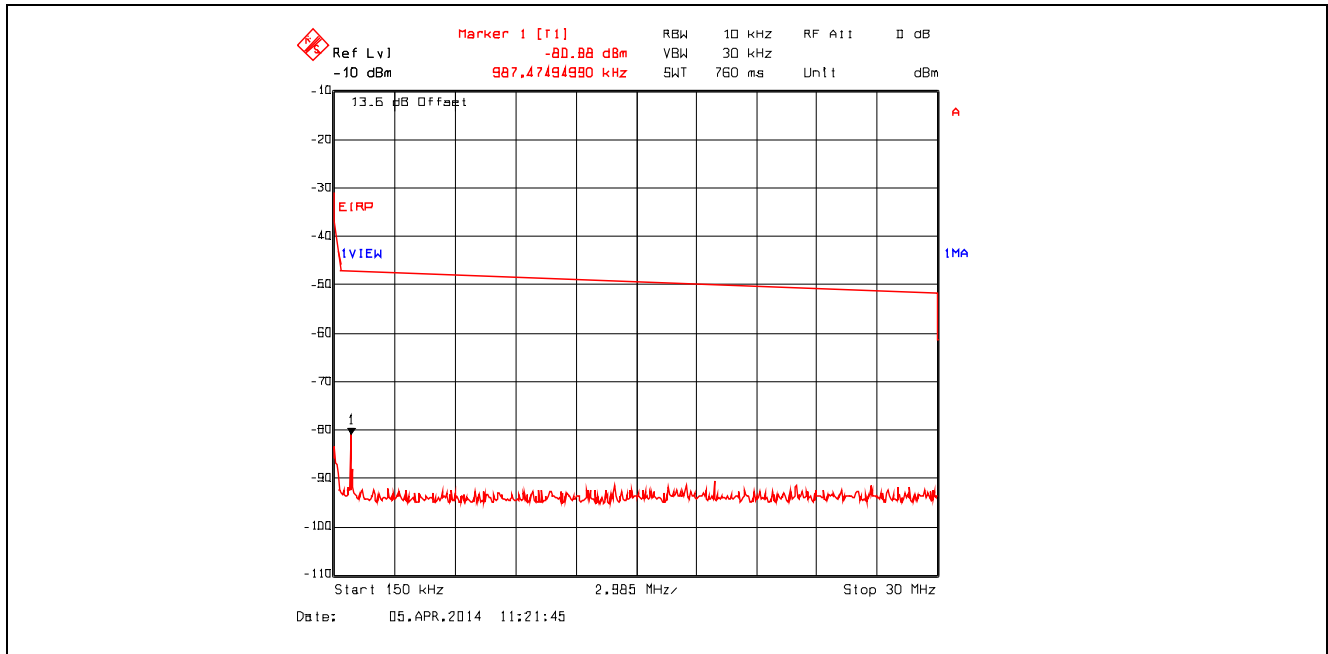

Plot 5.4.4.3.3. Conducted Spurious Emissions – Restricted Bands
 802.11b, 1 Mbps, 2412 MHz, 30 MHz - 1 GHz, Peak Detector with Band (Notch) Reject Filter

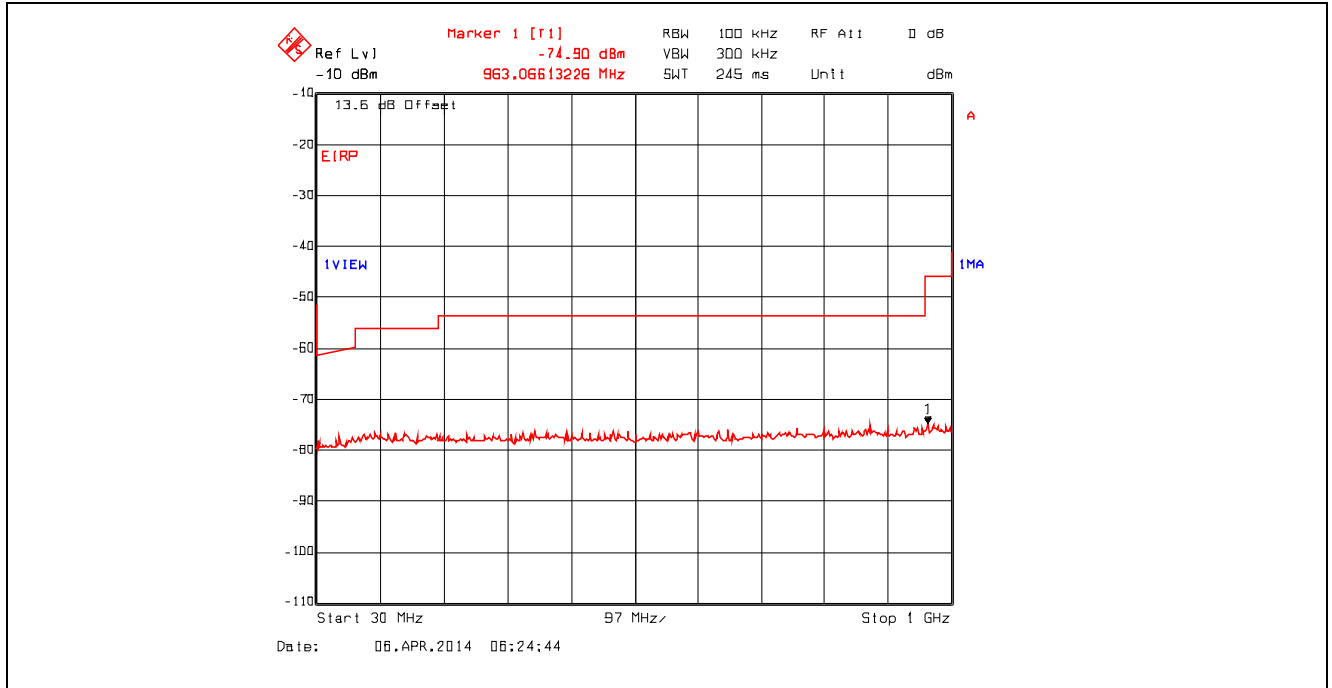

Plot 5.4.4.3.4. Conducted Spurious Emissions – Restricted Bands
 802.11b, 1 Mbps, 2412 MHz, 1 GHz - 4 GHz, RMS Detector with Band (Notch) Reject Filter

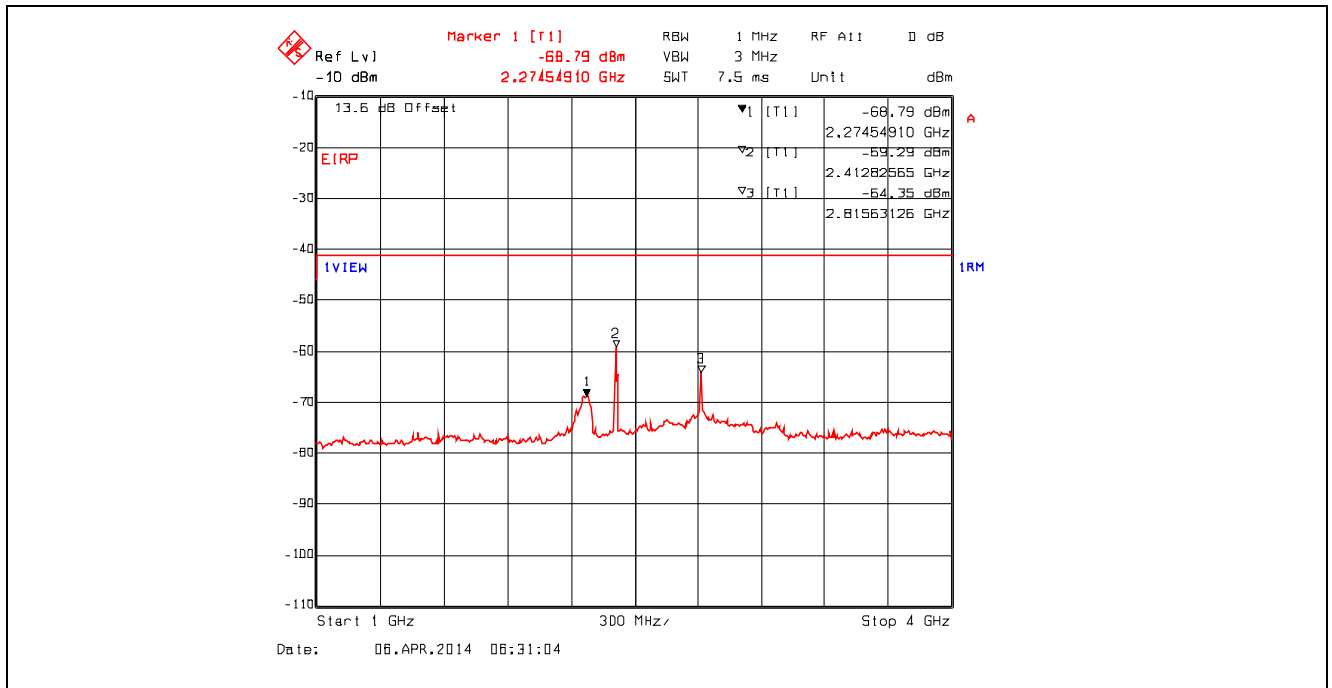

Plot 5.4.4.3.5. Conducted Spurious Emissions – Restricted Bands
 802.11b, 1 Mbps, 2412 MHz, 4 GHz - 25 GHz, RMS Detector with High Pass Filter

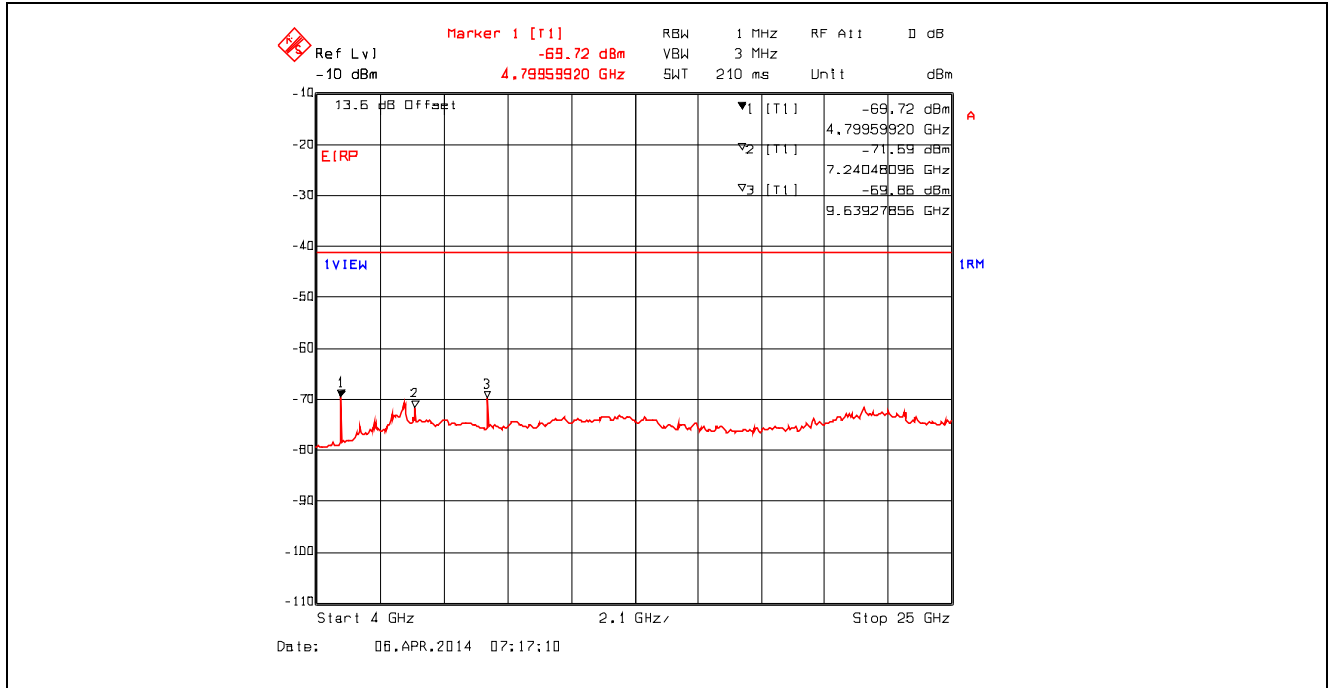

Plot 5.4.4.3.6. Conducted Spurious Emissions – Restricted Bands
 802.11b, 1 Mbps, 2437 MHz, 9 kHz - 150 kHz, Peak Detector with Band (Notch) Reject Filter

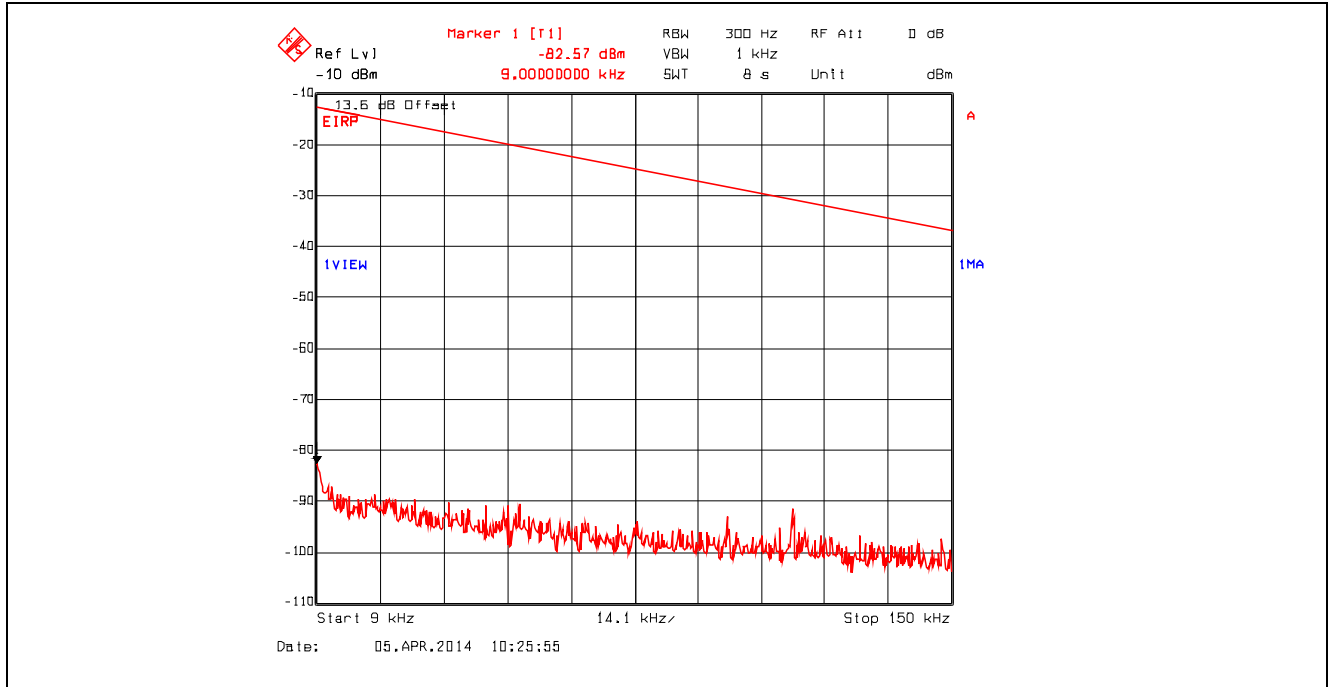

Plot 5.4.4.3.7. Conducted Spurious Emissions – Restricted Bands
 802.11b, 1 Mbps, 2437 MHz, 150 kHz - 30 MHz, Peak Detector with Band (Notch) Reject Filter

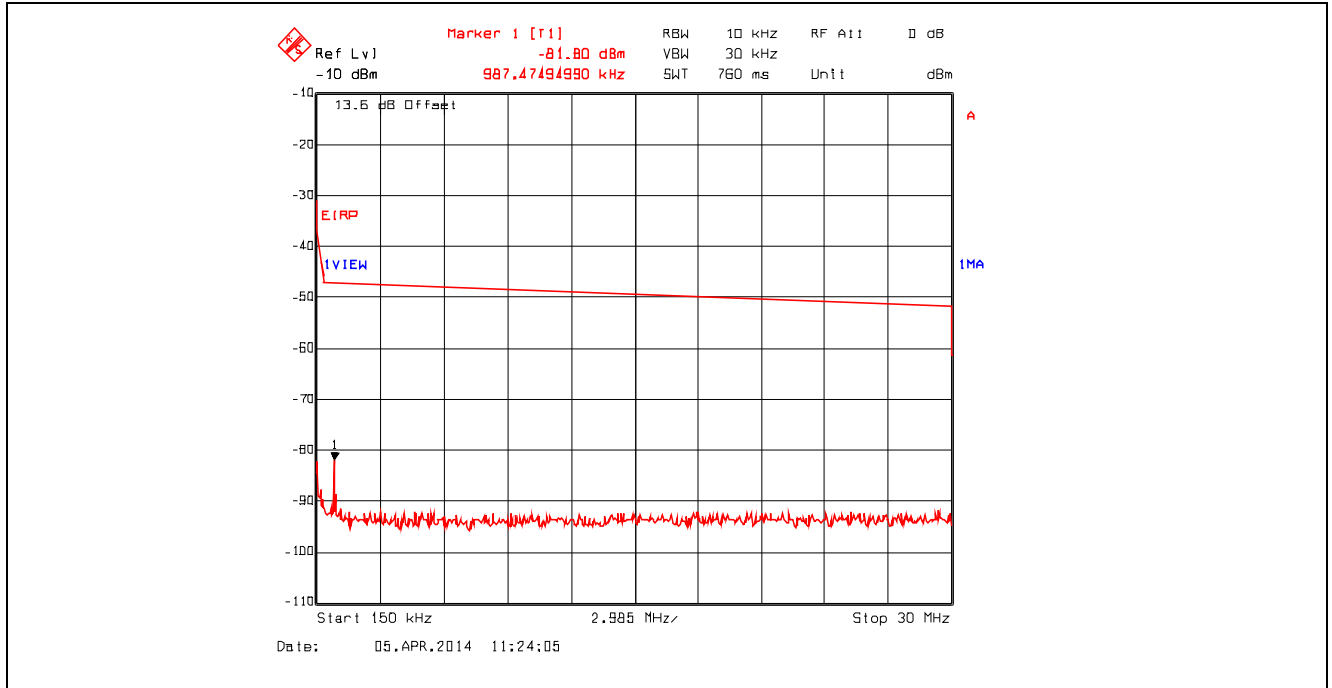

Plot 5.4.4.3.8. Conducted Spurious Emissions – Restricted Bands, Bands
 802.11b, 1 Mbps, 2437 MHz, 30 MHz - 1 GHz, Peak Detector with Band (Notch) Reject Filter

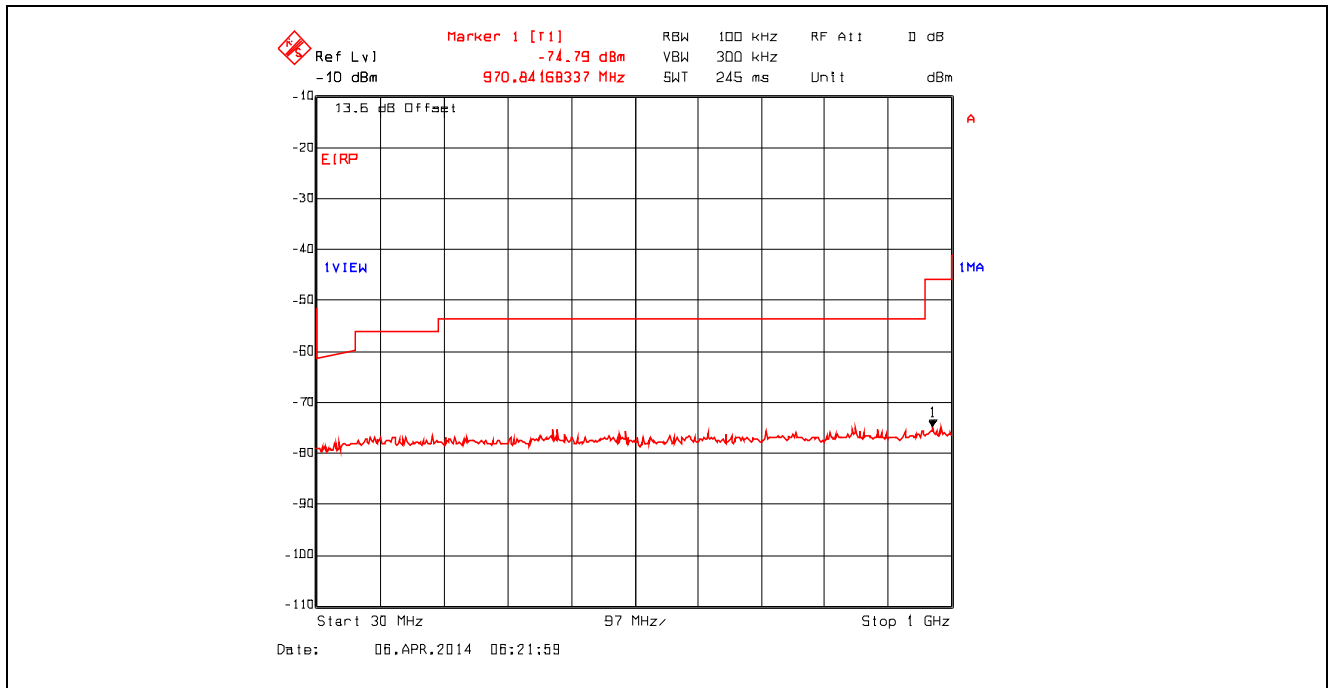

Plot 5.4.4.3.9. Conducted Spurious Emissions – Restricted Bands
 802.11b, 1 Mbps, 2437 MHz, 1 GHz - 4 GHz, RMS Detector with Band (Notch) Reject Filter

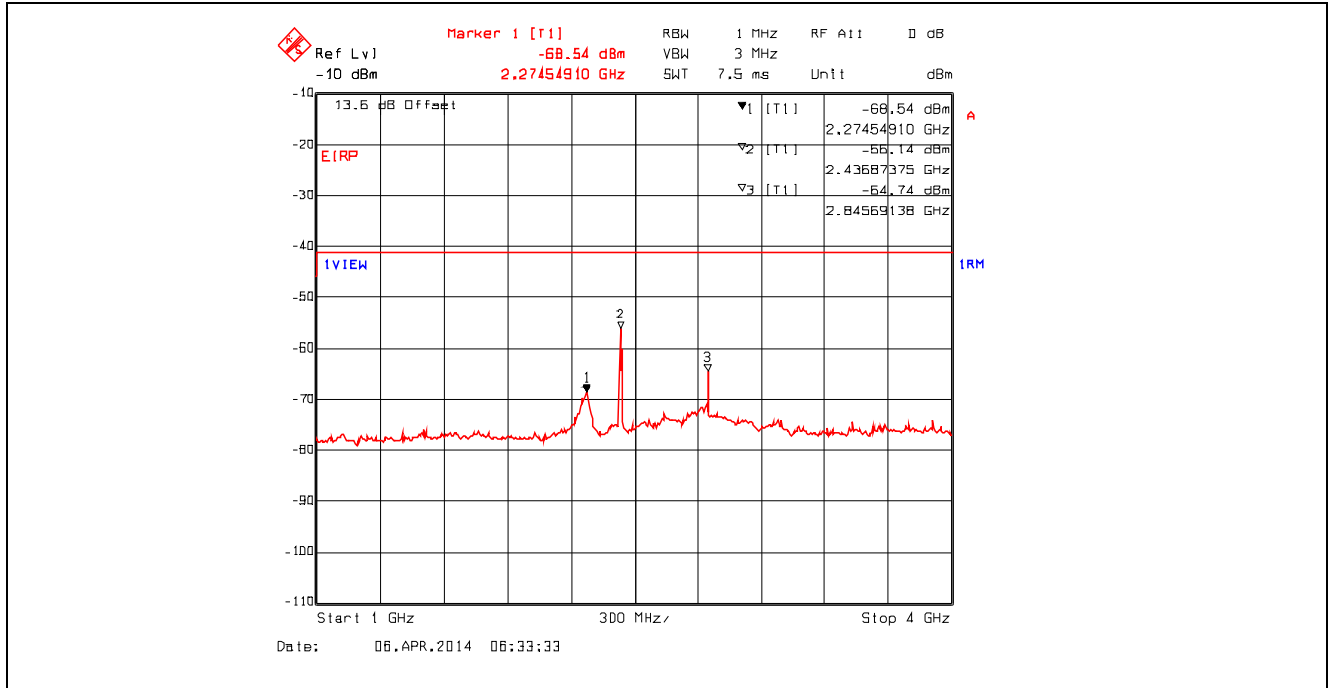

Plot 5.4.4.3.10. Conducted Spurious Emissions – Restricted Bands
 802.11b, 1 Mbps, 2437 MHz, 4 GHz - 25 GHz, RMS Detector with High Pass Filter

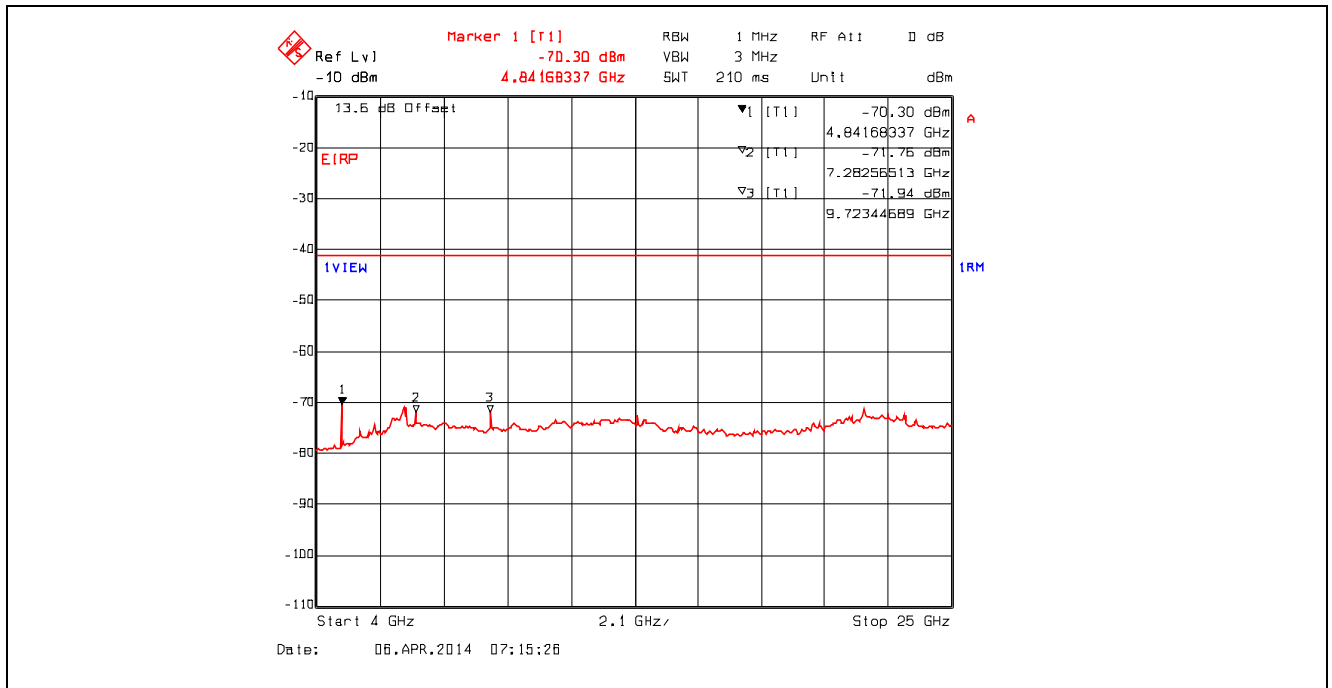

Plot 5.4.4.3.11. Conducted Spurious Emissions – Restricted Bands
 802.11b, 1 Mbps, 2462 MHz, 9 kHz - 150 kHz, Peak Detector with Band (Notch) Reject Filter

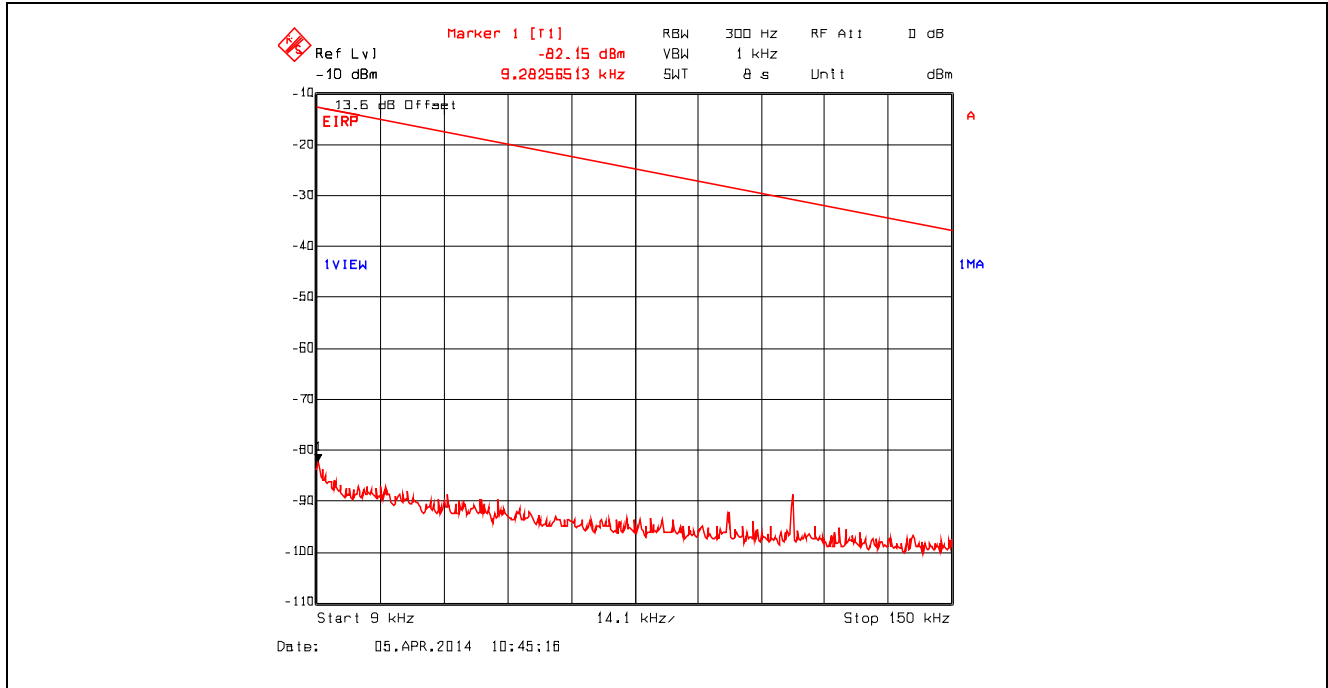

Plot 5.4.4.3.12. Conducted Spurious Emissions – Restricted Bands
 802.11b, 1 Mbps, 2462 MHz, 150 kHz - 30 MHz, Peak Detector with Band (Notch) Reject Filter

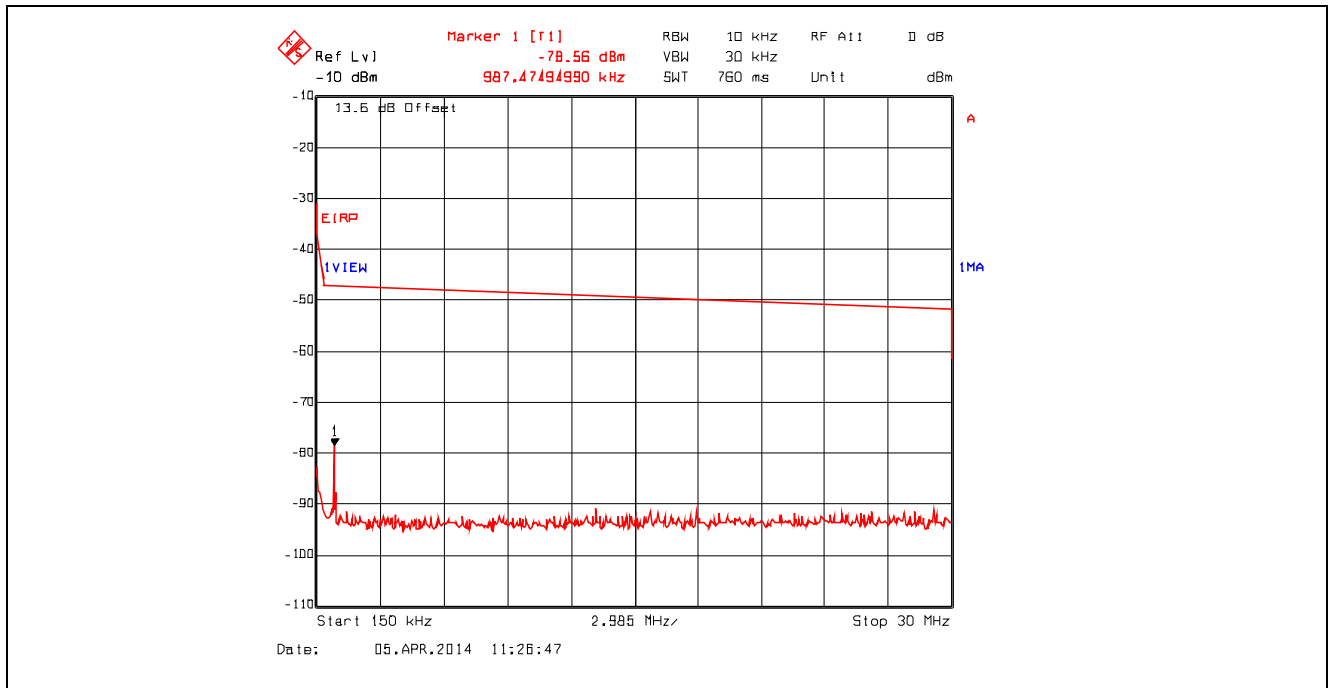

Plot 5.4.4.3.13. Conducted Spurious Emissions – Restricted Bands
 802.11b, 1 Mbps, 2462 MHz, 30 MHz - 1 GHz, Peak Detector with Band (Notch) Reject Filter

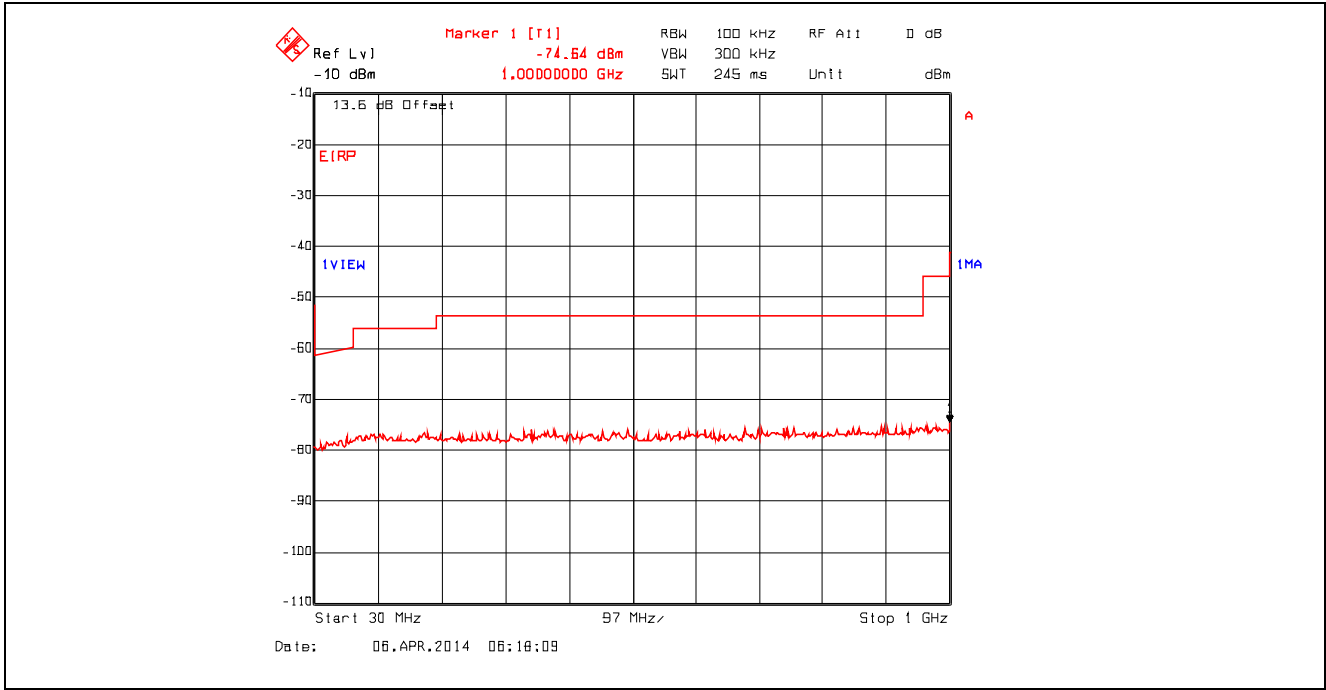

Plot 5.4.4.3.14. Conducted Spurious Emissions – Restricted Bands
 802.11b, 1 Mbps, 2462 MHz, 1 GHz - 4 GHz, RMS Detector with Band (Notch) Reject Filter

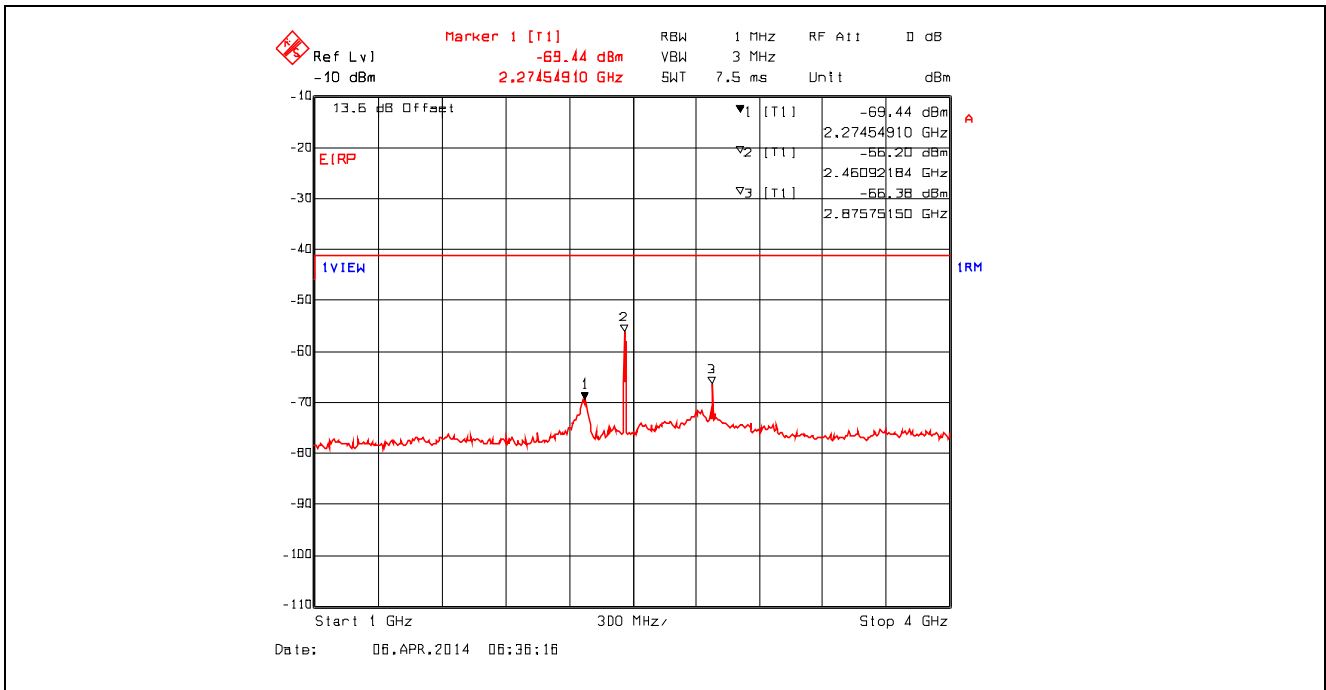

Plot 5.4.4.3.15. Conducted Spurious Emissions – Restricted Bands
 802.11b, 1 Mbps, 2462 MHz, 4 GHz - 25 GHz, RMS Detector with High Pass Filter

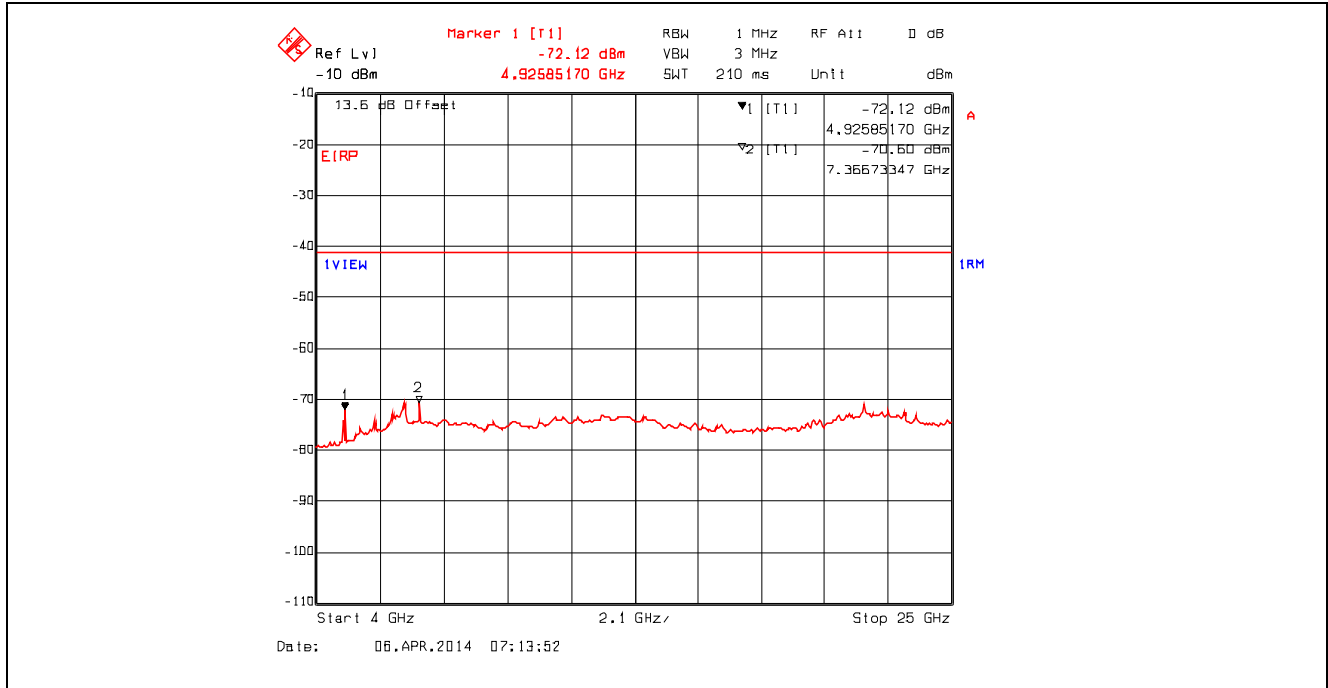

Plot 5.4.4.3.16. Conducted Spurious Emissions – Restricted Bands
 802.11g, 9 Mbps, 2412 MHz, 9 kHz - 150 kHz, Peak Detector with Band (Notch) Reject Filter

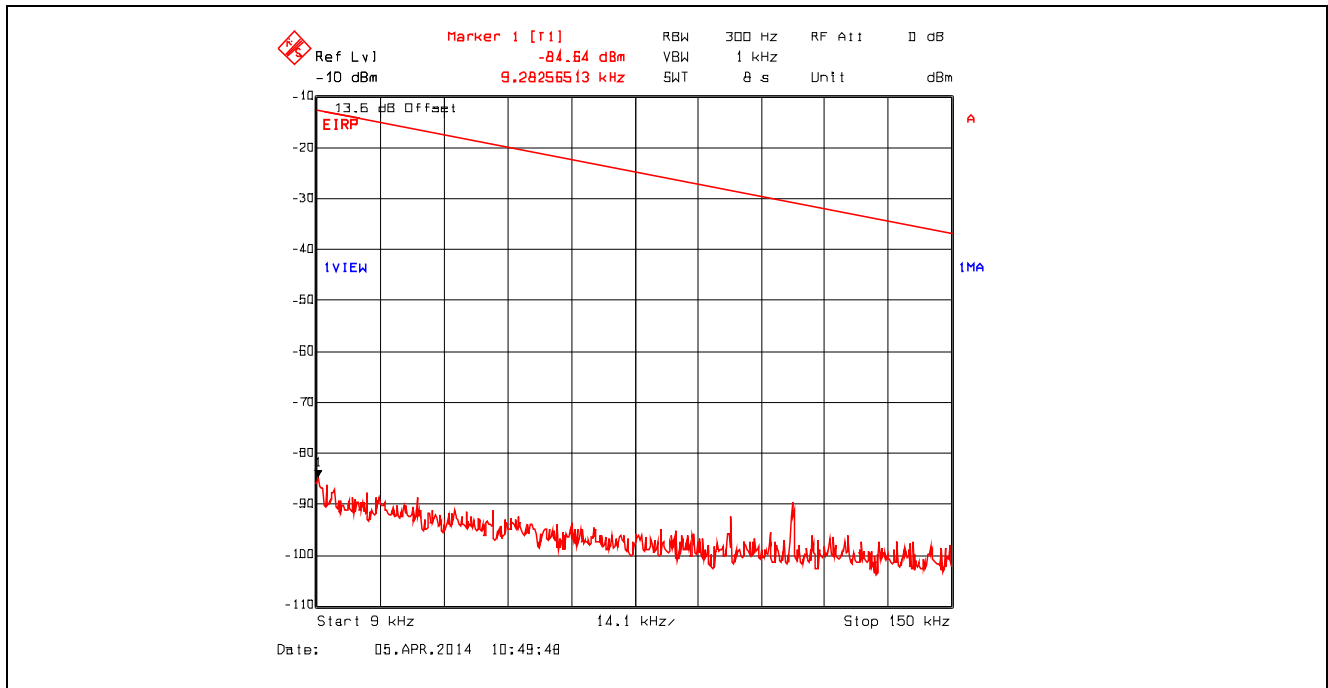

Plot 5.4.4.3.17. Conducted Spurious Emissions – Restricted Bands
 802.11g, 9 Mbps, 2412 MHz, 150 kHz - 30 MHz, Peak Detector with Band (Notch) Reject Filter

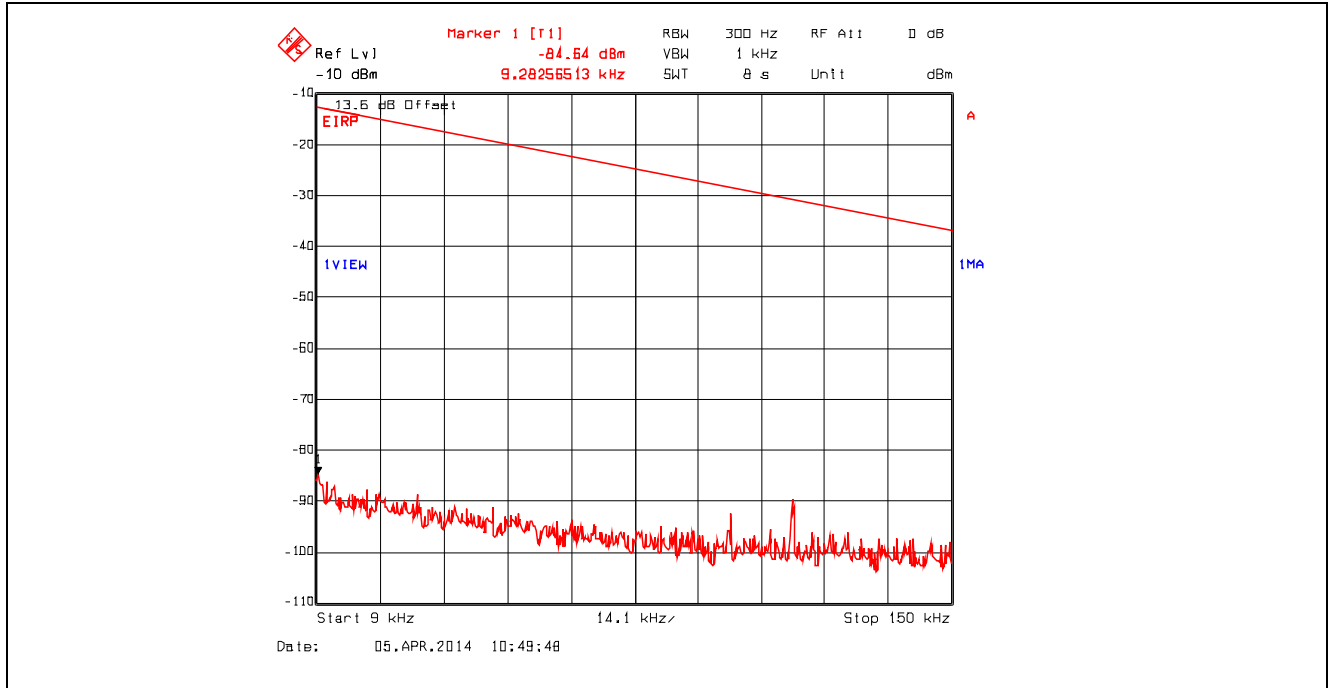

Plot 5.4.4.3.18. Conducted Spurious Emissions – Restricted Bands
 802.11g, 9 Mbps, 2412 MHz, 30 MHz - 1 GHz, Peak Detector with Band (Notch) Reject Filter

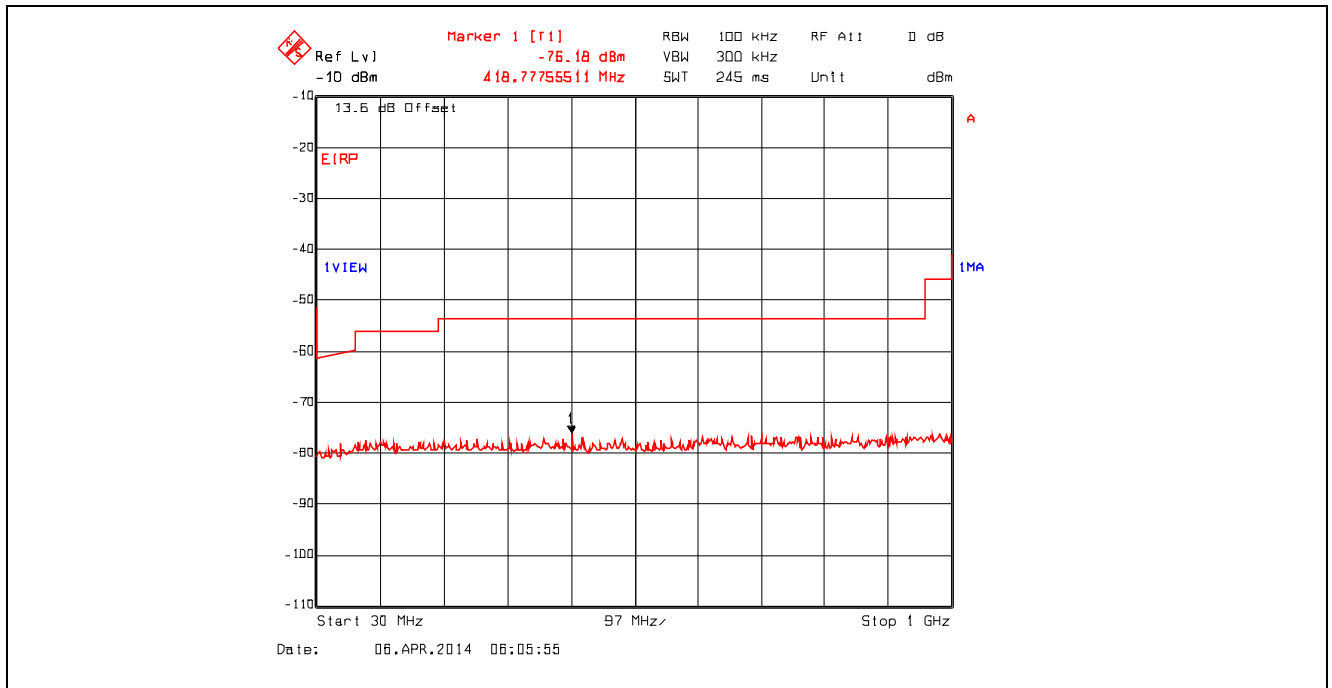

Plot 5.4.4.3.19. Conducted Spurious Emissions – Restricted Bands
 802.11g, 9 Mbps, 2412 MHz, 1 GHz - 4 GHz, RMS Detector with Band (Notch) Reject Filter

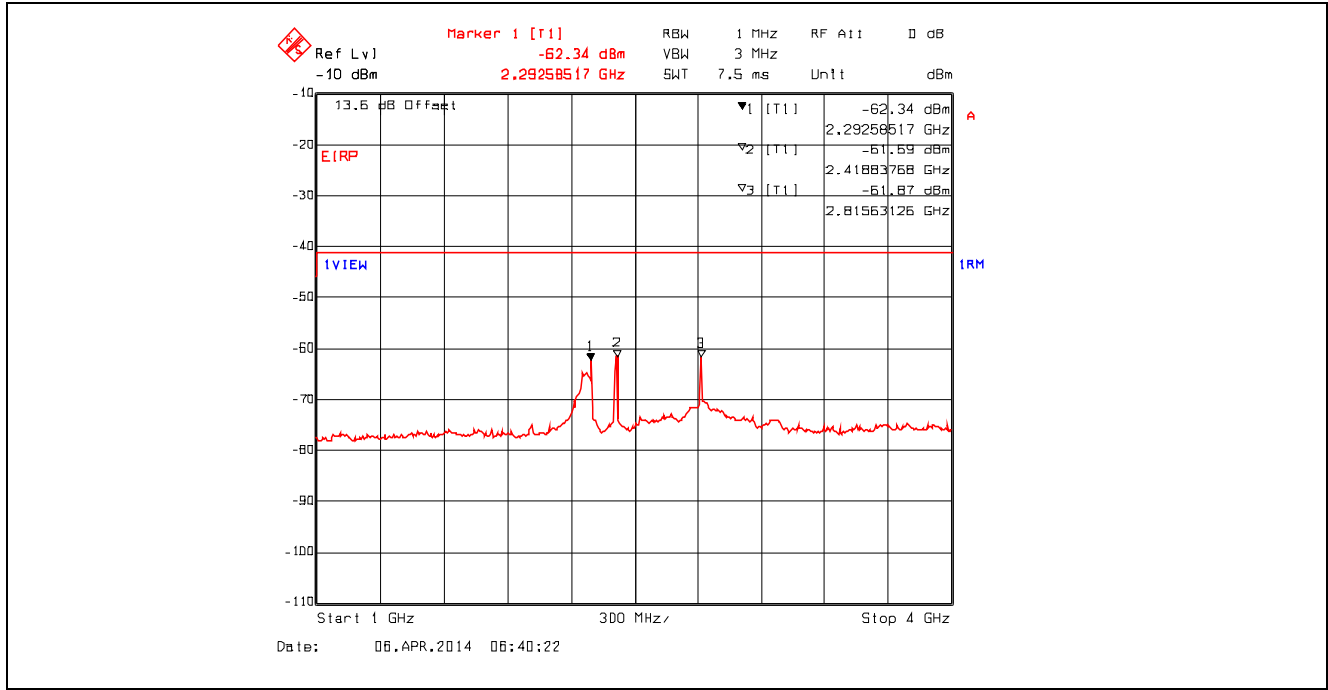

Plot 5.4.4.3.20. Conducted Spurious Emissions – Restricted Bands
 802.11g, 9 Mbps, 2412 MHz, 4 GHz - 25 GHz, RMS Detector with High Pass Filter

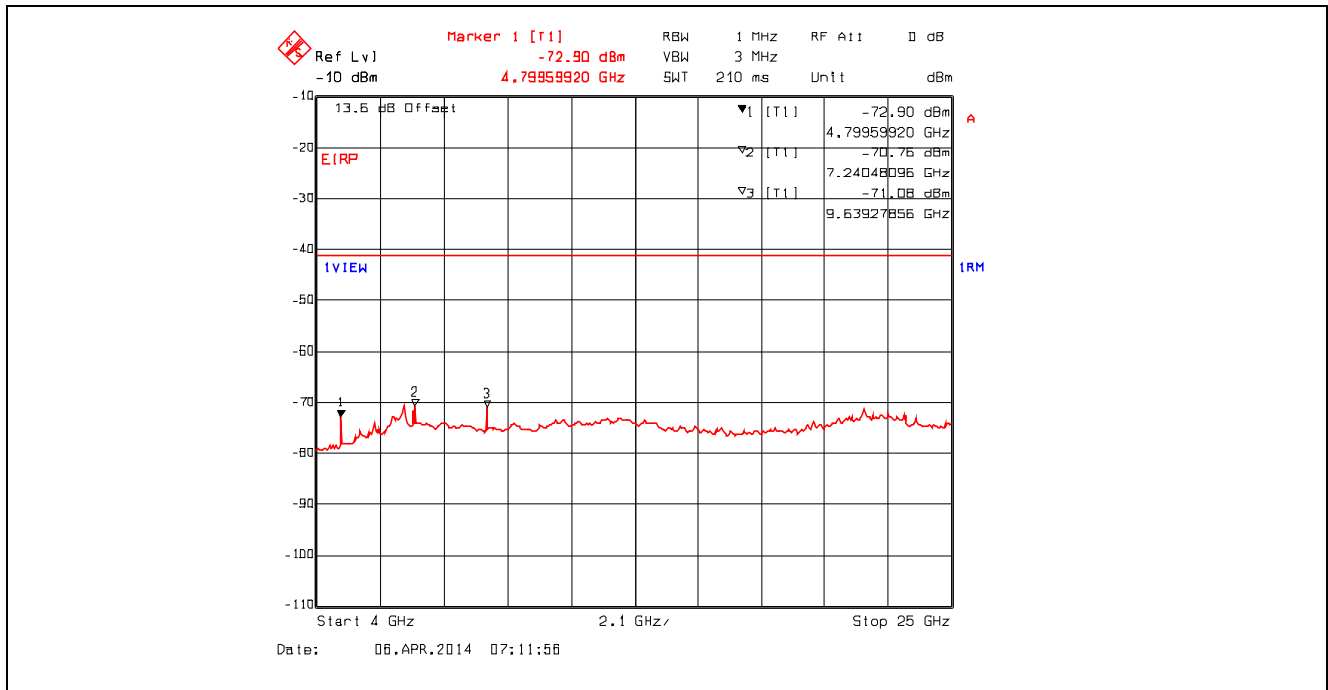

Plot 5.4.4.3.21. Conducted Spurious Emissions – Restricted Bands
 802.11g, 9 Mbps, 2437 MHz, 9 kHz - 150 kHz, Peak Detector with Band (Notch) Reject Filter

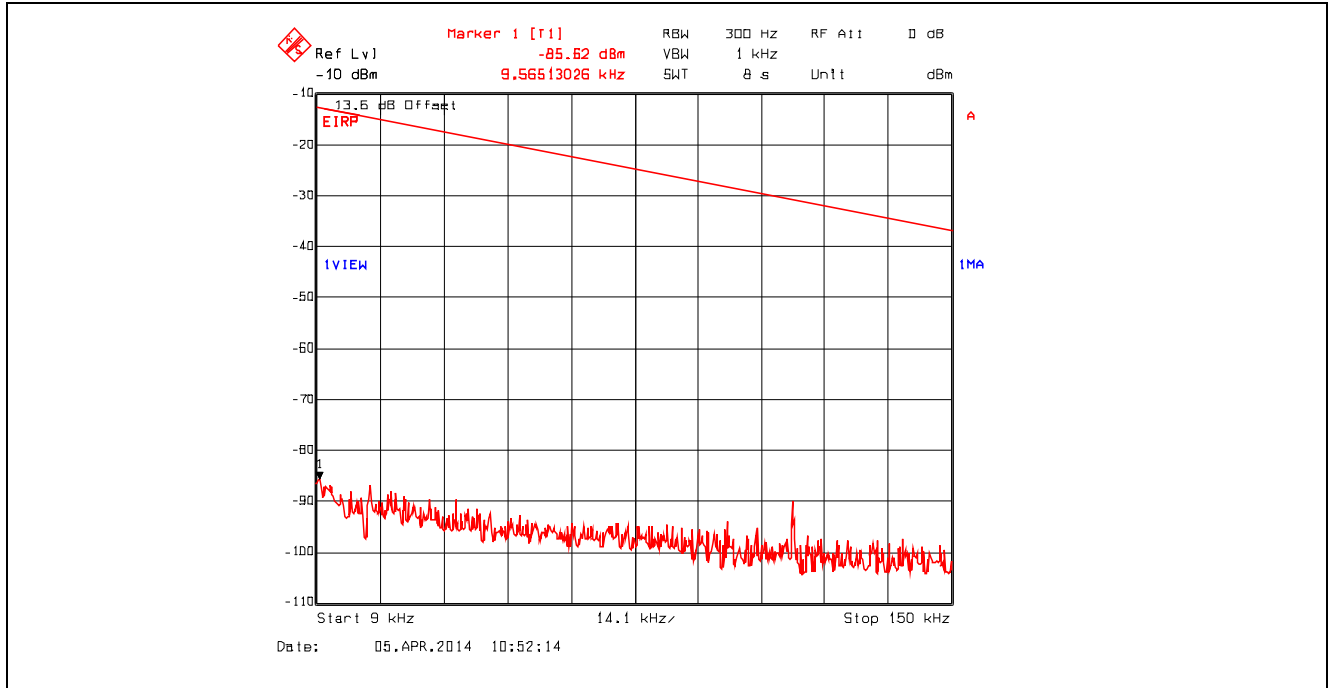

Plot 5.4.4.3.22. Conducted Spurious Emissions – Restricted Bands
 802.11g, 9 Mbps, 2437 MHz, 150 kHz - 30 MHz, Peak Detector with Band (Notch) Reject Filter

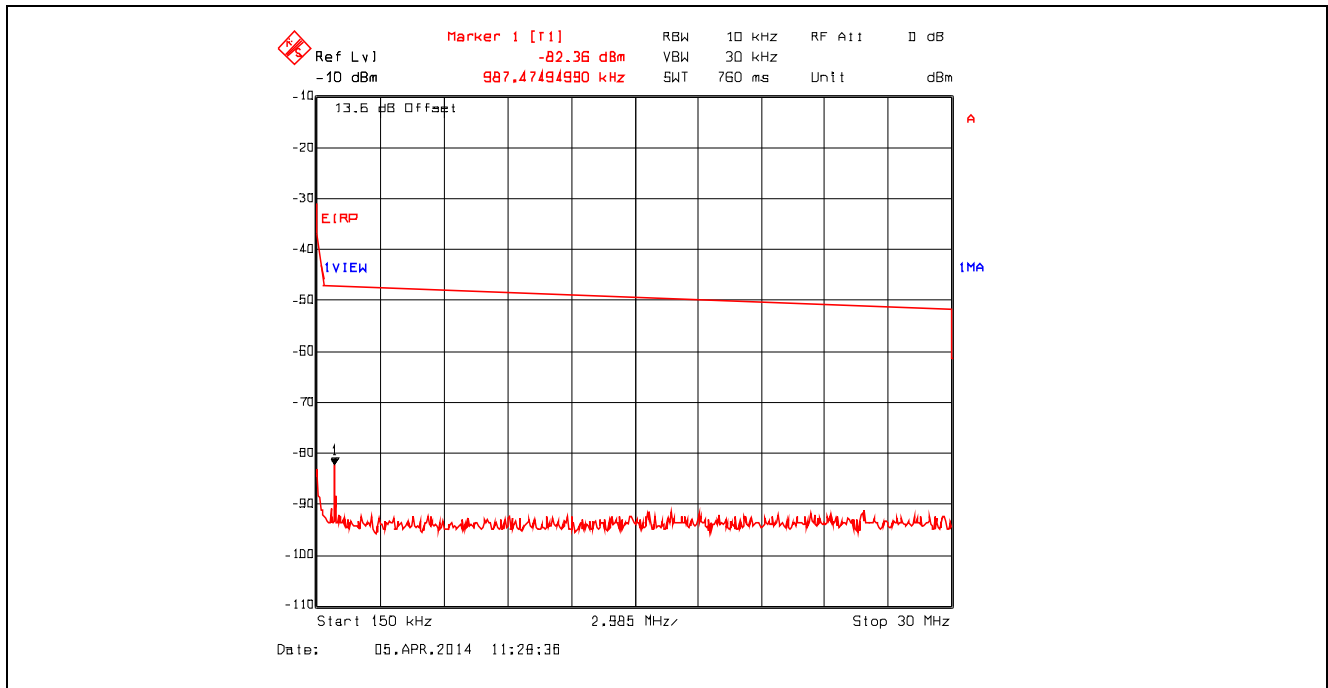

Plot 5.4.4.3.23. Conducted Spurious Emissions – Restricted Bands, Bands
 802.11g, 9 Mbps, 2437 MHz, 30 MHz - 1 GHz, Peak Detector with Band (Notch) Reject Filter

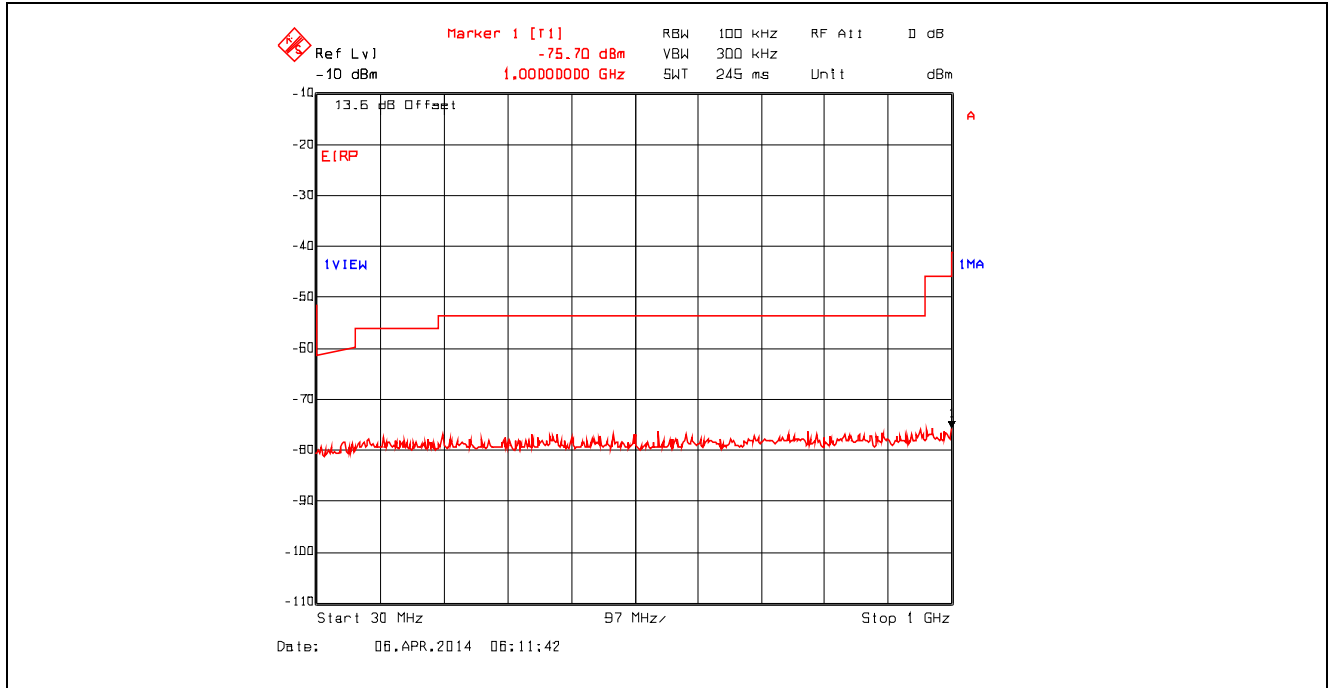

Plot 5.4.4.3.24. Conducted Spurious Emissions – Restricted Bands
 802.11g, 9 Mbps, 2437 MHz, 1 GHz - 4 GHz, RMS Detector with Band (Notch) Reject Filter

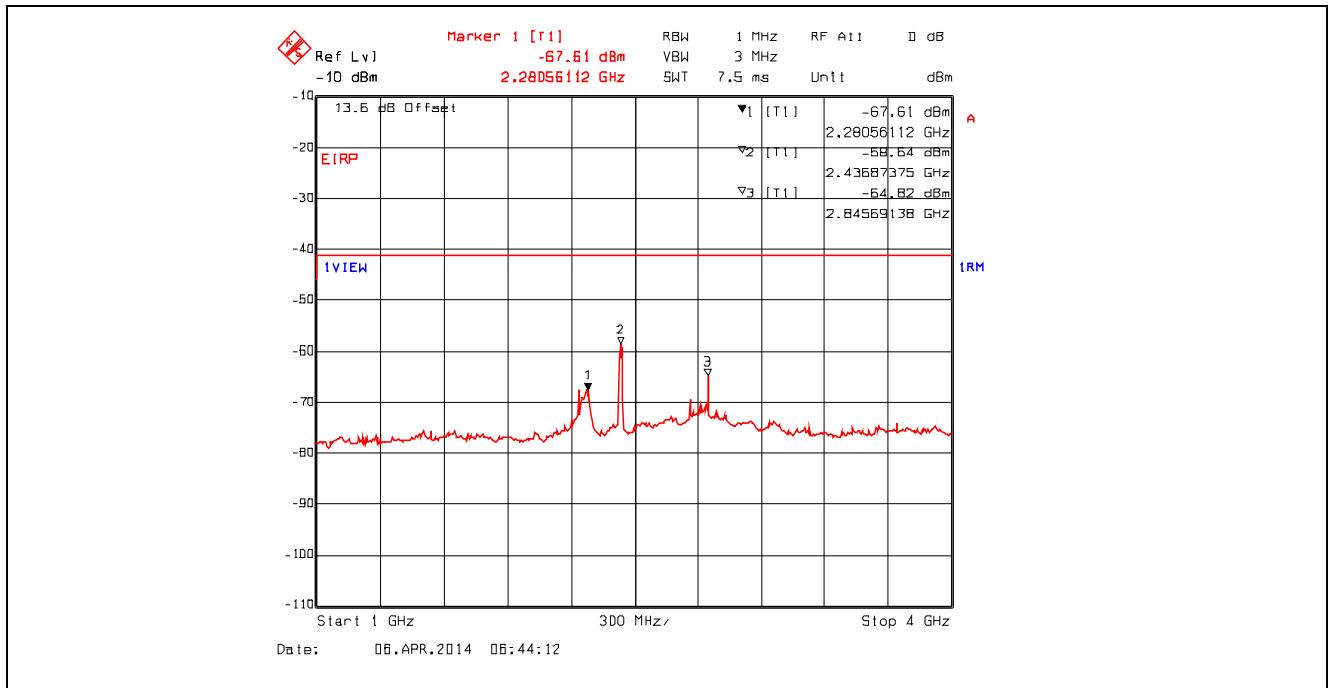

Plot 5.4.4.3.25. Conducted Spurious Emissions – Restricted Bands
 802.11g, 9 Mbps, 2437 MHz, 4 GHz - 25 GHz, RMS Detector with High Pass Filter

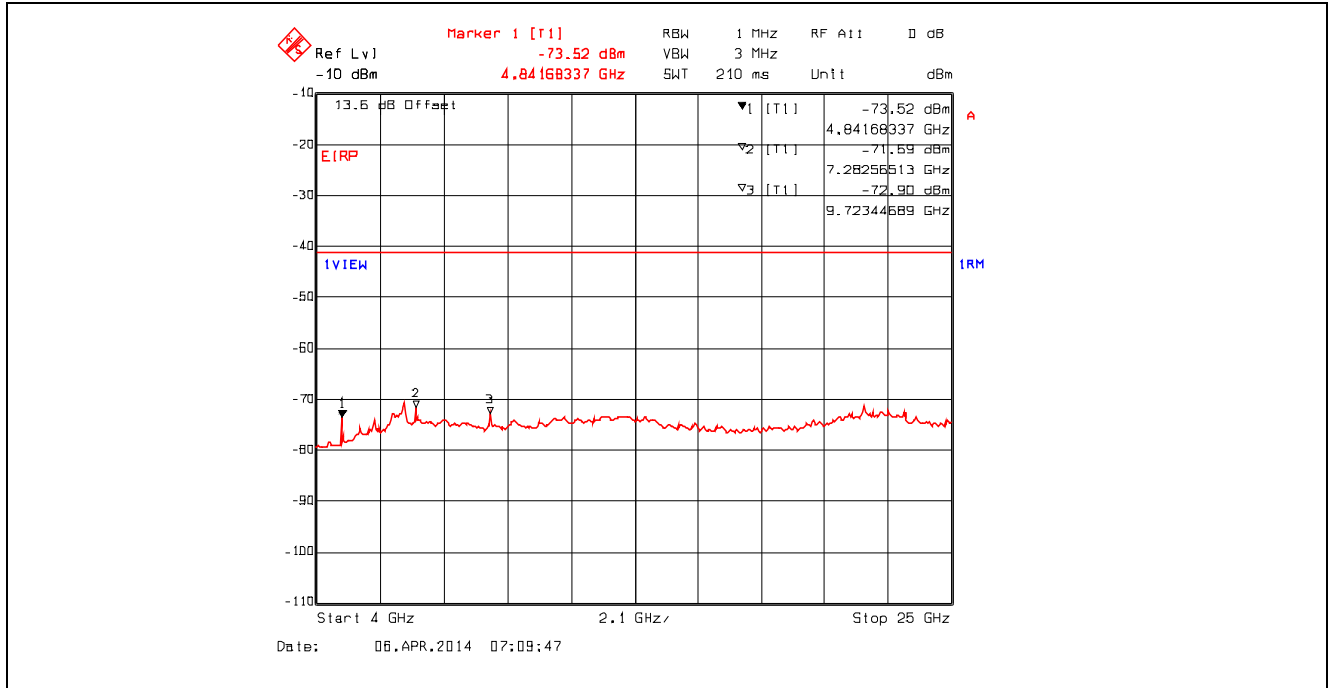

Plot 5.4.4.3.26. Conducted Spurious Emissions – Restricted Bands
 802.11g, 9 Mbps, 2462 MHz, 9 kHz - 150 kHz, Peak Detector with Band (Notch) Reject Filter

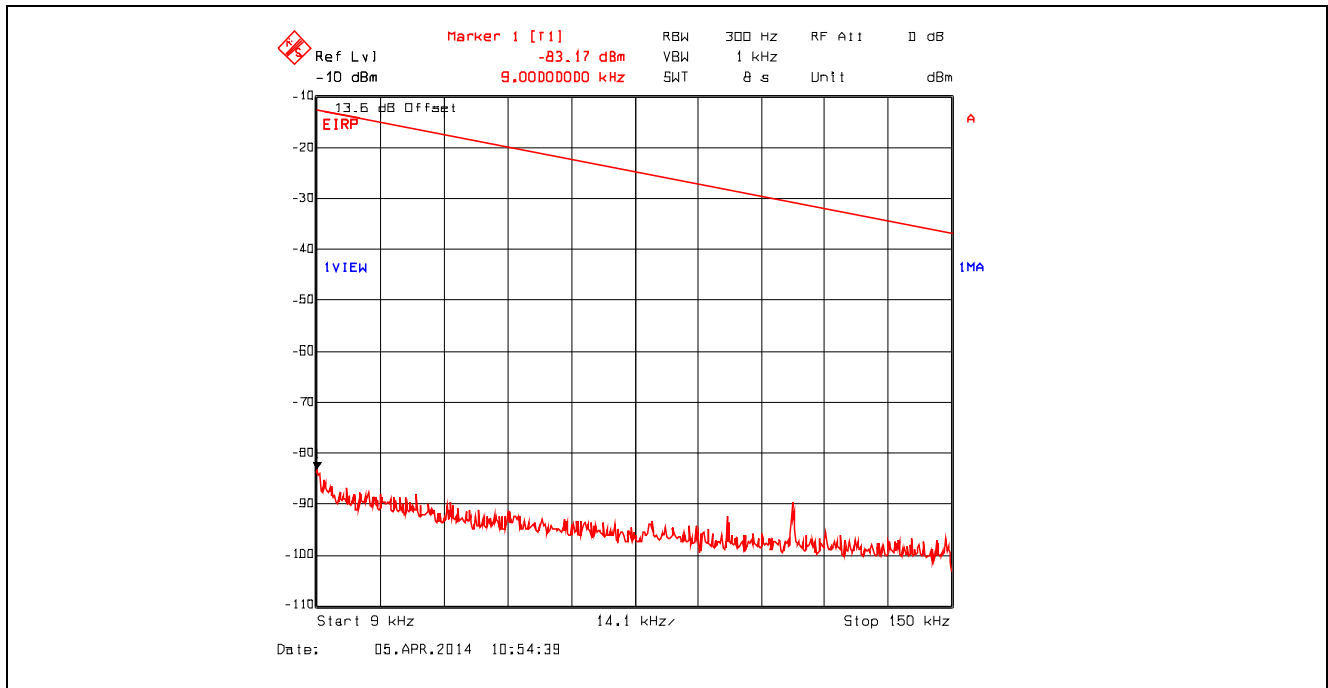

Plot 5.4.4.3.27. Conducted Spurious Emissions – Restricted Bands
 802.11g, 9 Mbps, 2462 MHz, 150 kHz - 30 MHz, Peak Detector with Band (Notch) Reject Filter

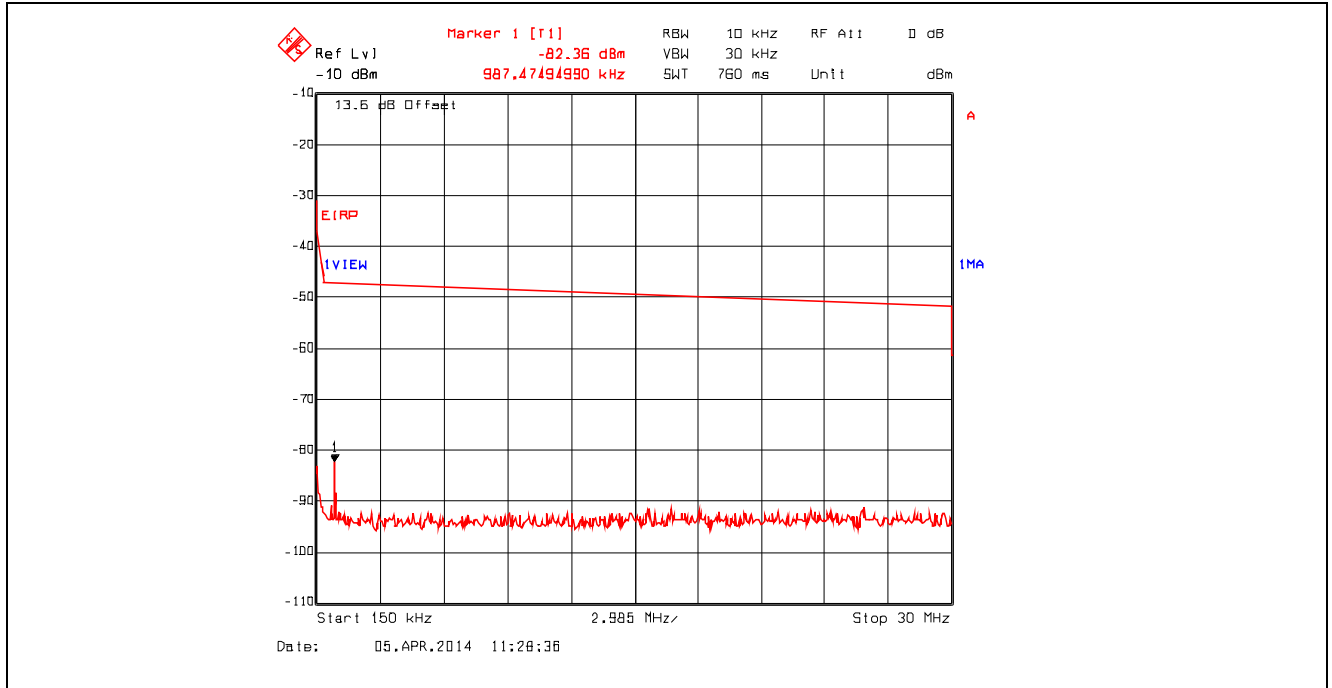

Plot 5.4.4.3.28. Conducted Spurious Emissions – Restricted Bands
 802.11g, 9 Mbps, 2462 MHz, 30 MHz - 1 GHz, Peak Detector with Band (Notch) Reject Filter

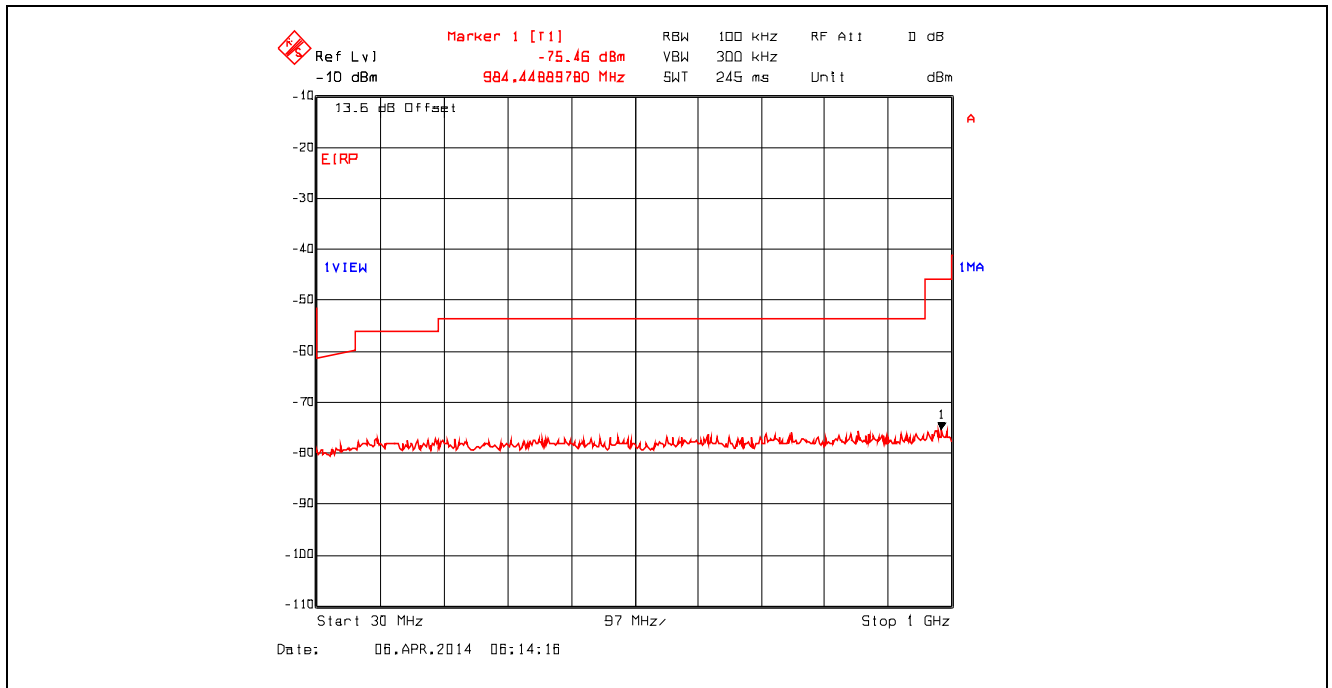

Plot 5.4.4.3.29. Conducted Spurious Emissions – Restricted Bands
 802.11g, 9 Mbps, 2462 MHz, 1 GHz - 4 GHz, RMS Detector with Band (Notch) Reject Filter

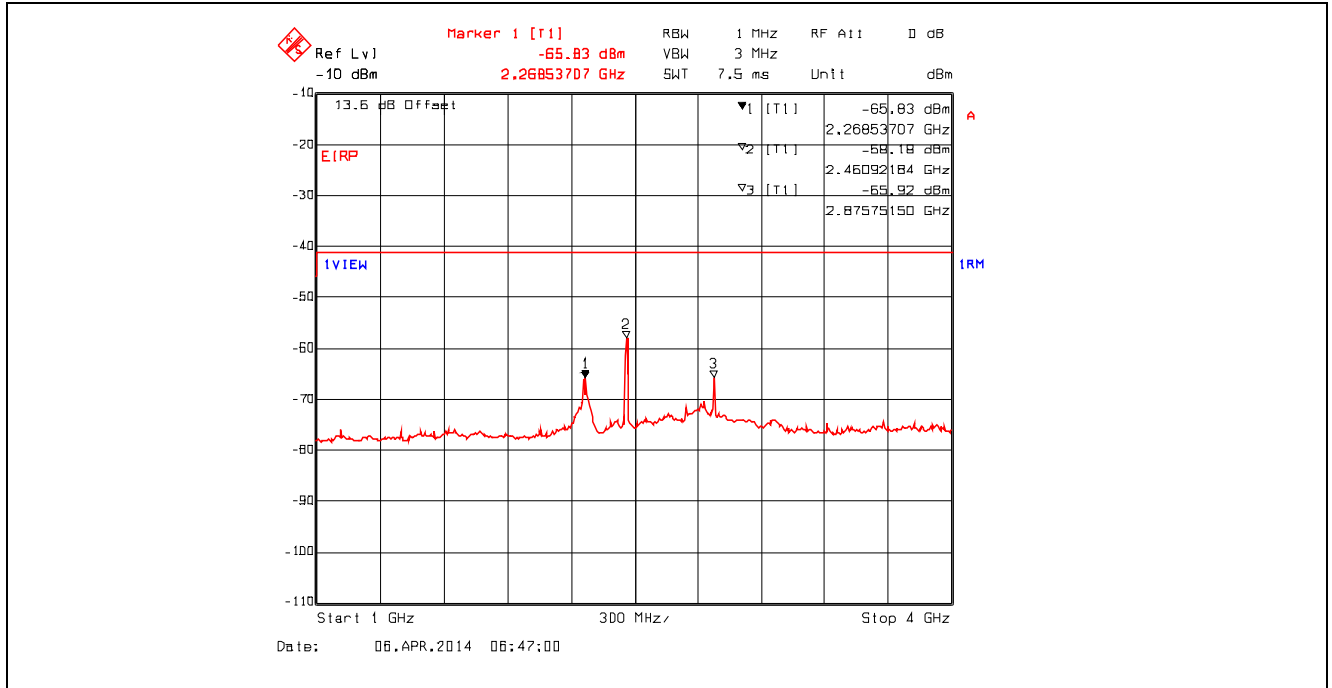

Plot 5.4.4.3.30. Conducted Spurious Emissions – Restricted Bands
 802.11g, 9 Mbps, 2462 MHz, 4 GHz - 25 GHz, RMS Detector with High Pass Filter

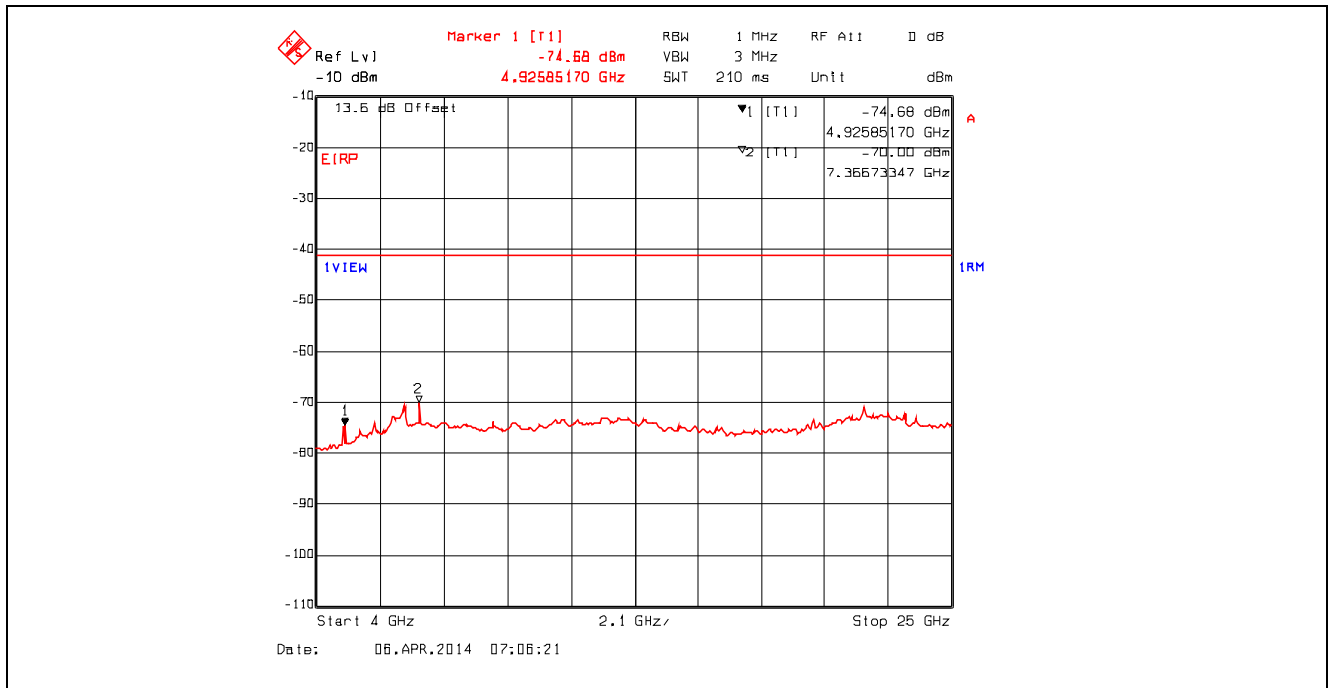

Plot 5.4.4.3.31. Conducted Spurious Emissions – Restricted Bands
 802.11n, 6.5 Mbps, 2412 MHz, 9 kHz - 150 kHz, Peak Detector with Band (Notch) Reject Filter

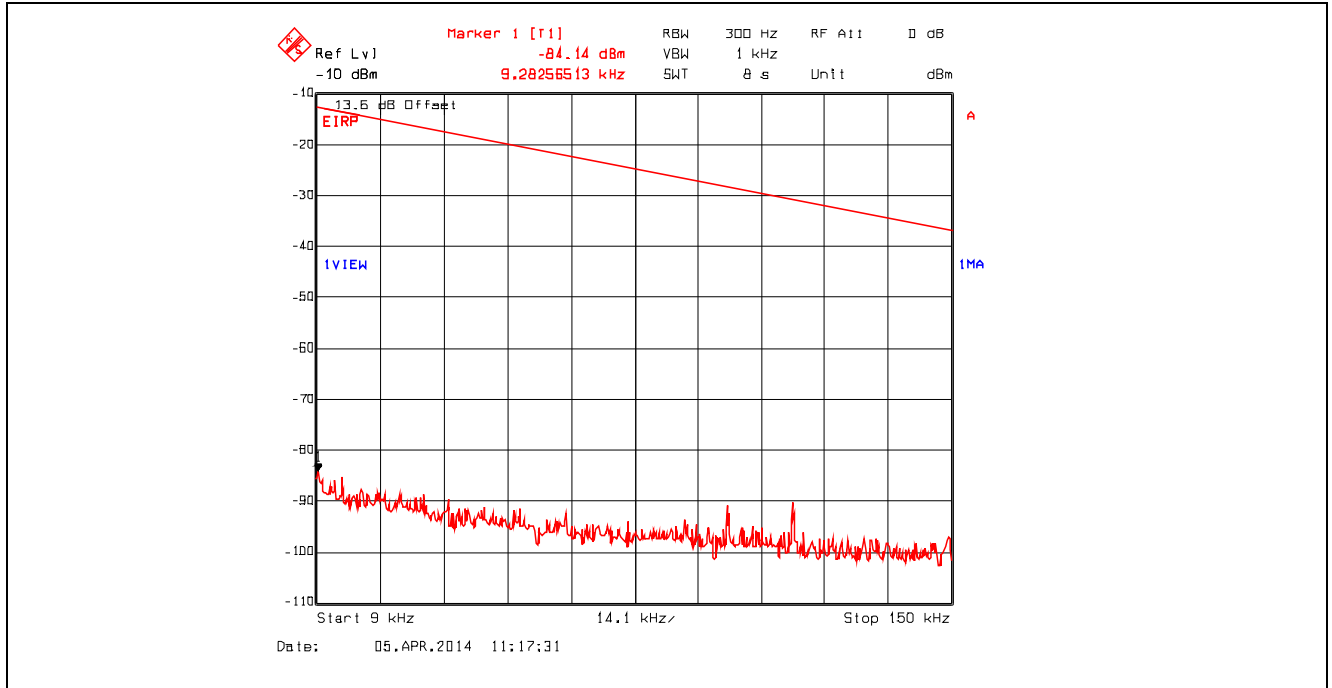

Plot 5.4.4.3.32. Conducted Spurious Emissions – Restricted Bands
 802.11n, 6.5 Mbps, 2412 MHz, 150 kHz - 30 MHz, Peak Detector with Band (Notch) Reject Filter

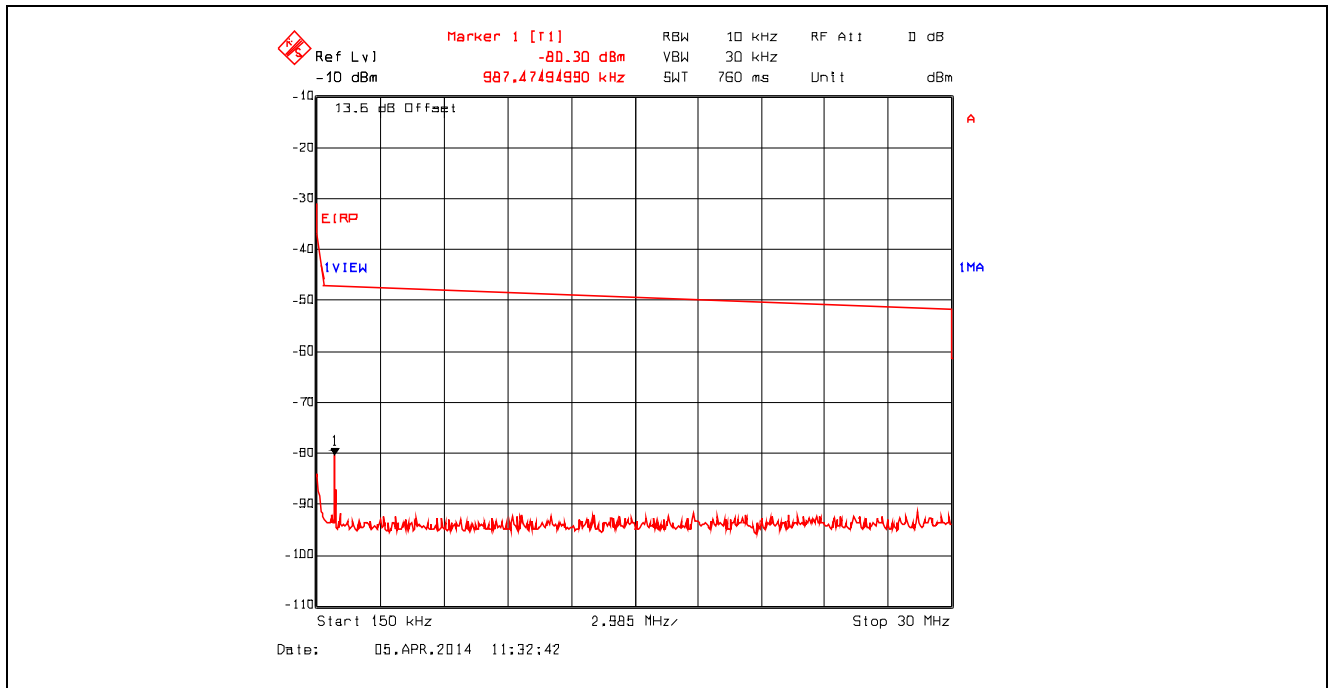

Plot 5.4.4.33. Conducted Spurious Emissions – Restricted Bands
 802.11n, 6.5 Mbps, 2412 MHz, 30 MHz - 1 GHz, Peak Detector with Band (Notch) Reject Filter

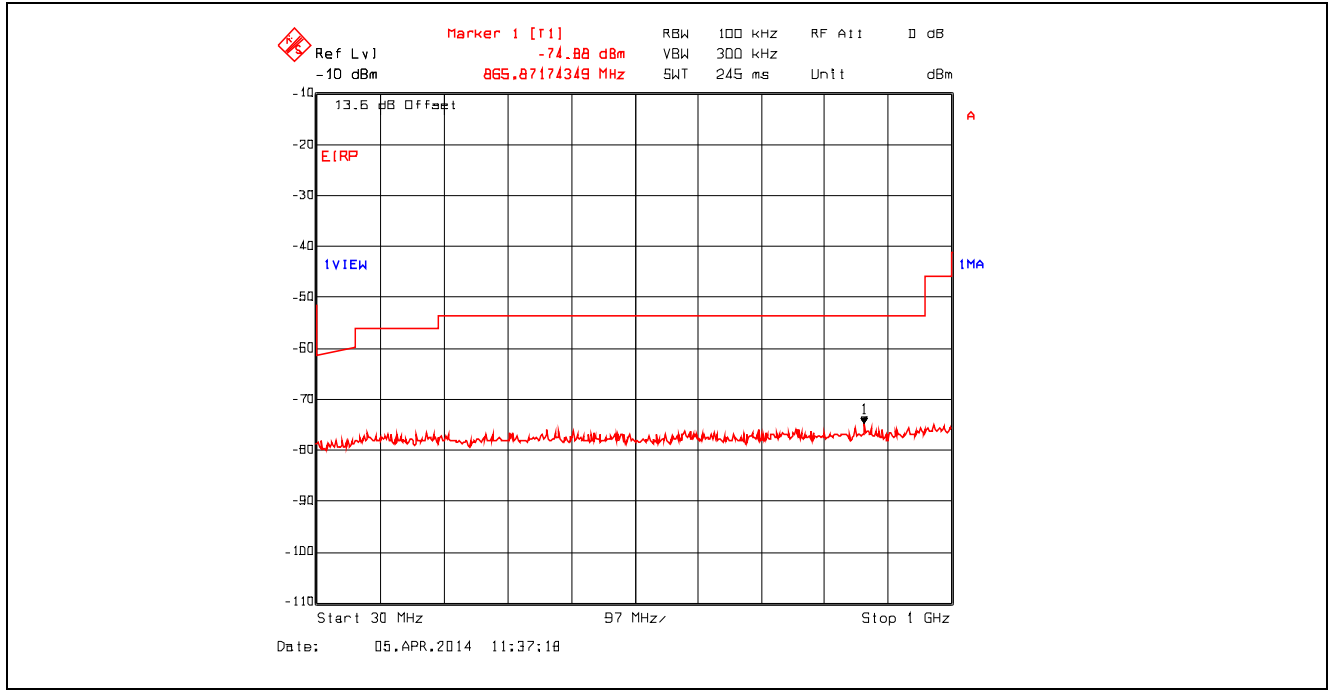

Plot 5.4.4.34. Conducted Spurious Emissions – Restricted Bands
 802.11n, 6.5 Mbps, 2412 MHz, 1 GHz - 4 GHz, RMS Detector with Band (Notch) Reject Filter

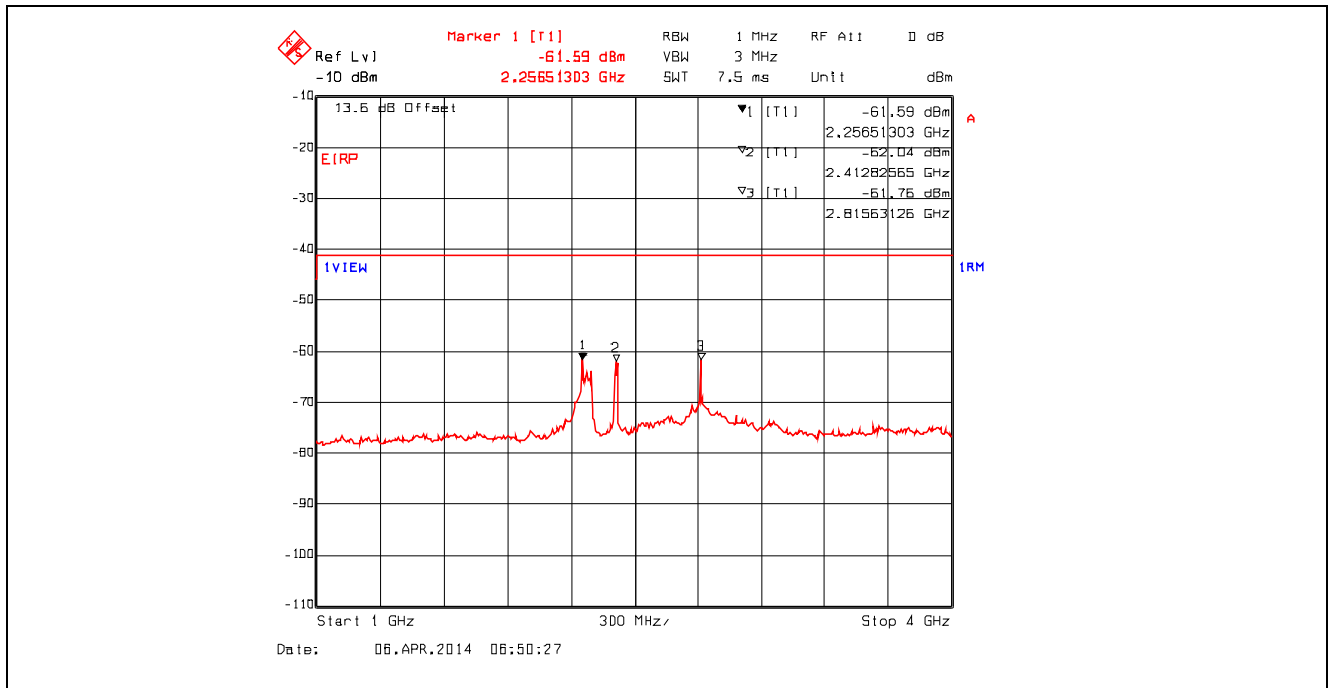

Plot 5.4.4.3.35. Conducted Spurious Emissions – Restricted Bands
 802.11n, 6.5 Mbps, 2412 MHz, 4 GHz - 25 GHz, RMS Detector with High Pass Filter

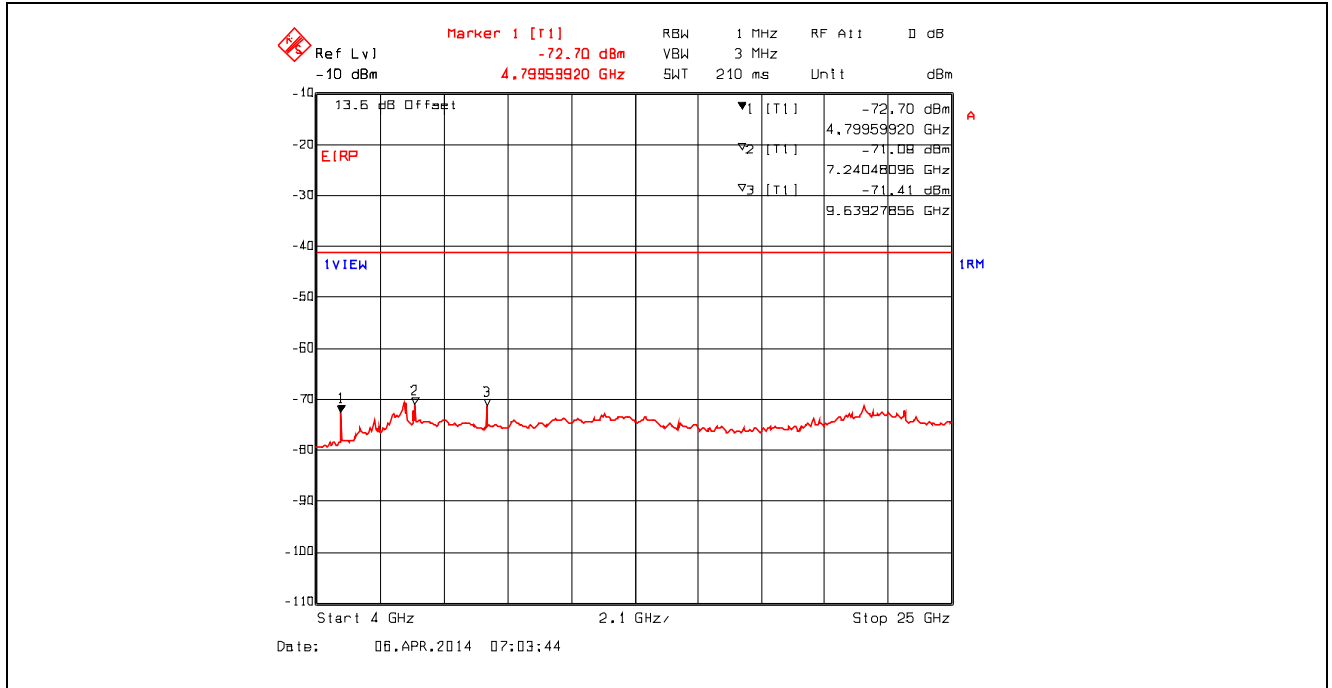

Plot 5.4.4.3.36. Conducted Spurious Emissions – Restricted Bands
 802.11n, 6.5 Mbps, 2437 MHz, 9 kHz - 150 kHz, Peak Detector with Band (Notch) Reject Filter

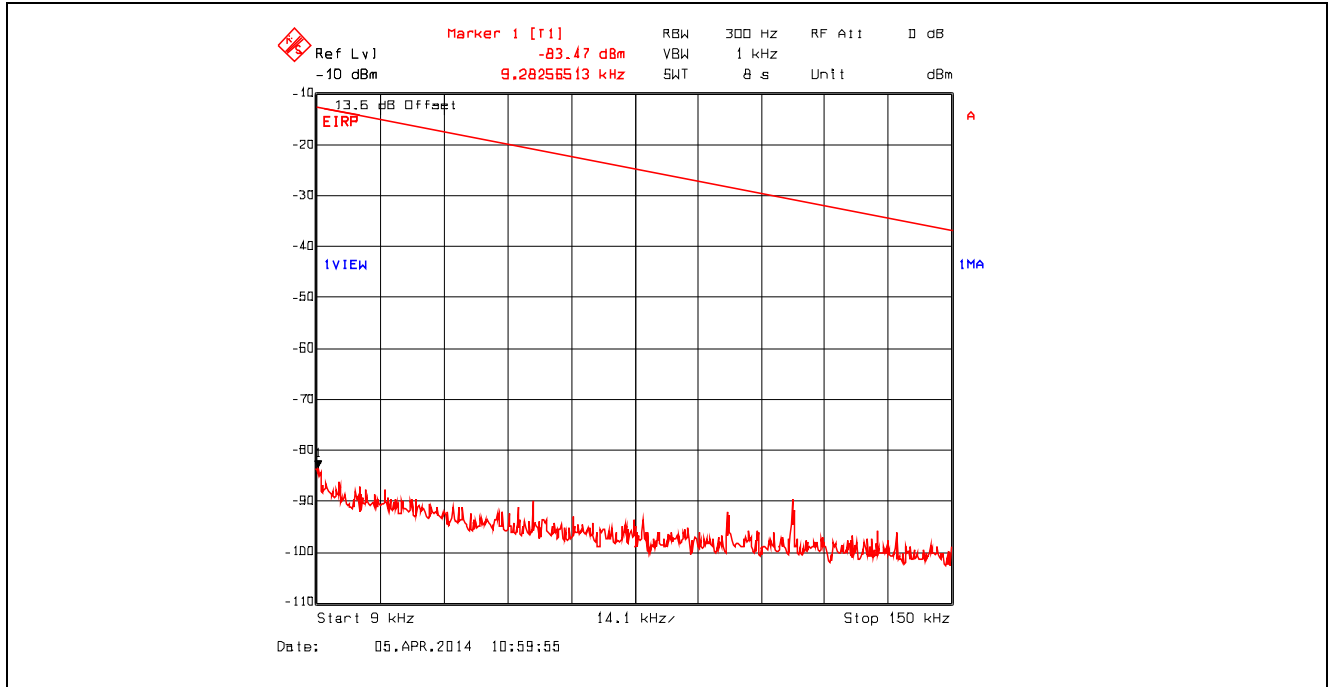

Plot 5.4.4.3.37. Conducted Spurious Emissions – Restricted Bands
 802.11n, 6.5 Mbps, 2437 MHz, 150 kHz - 30 MHz, Peak Detector with Band (Notch) Reject Filter

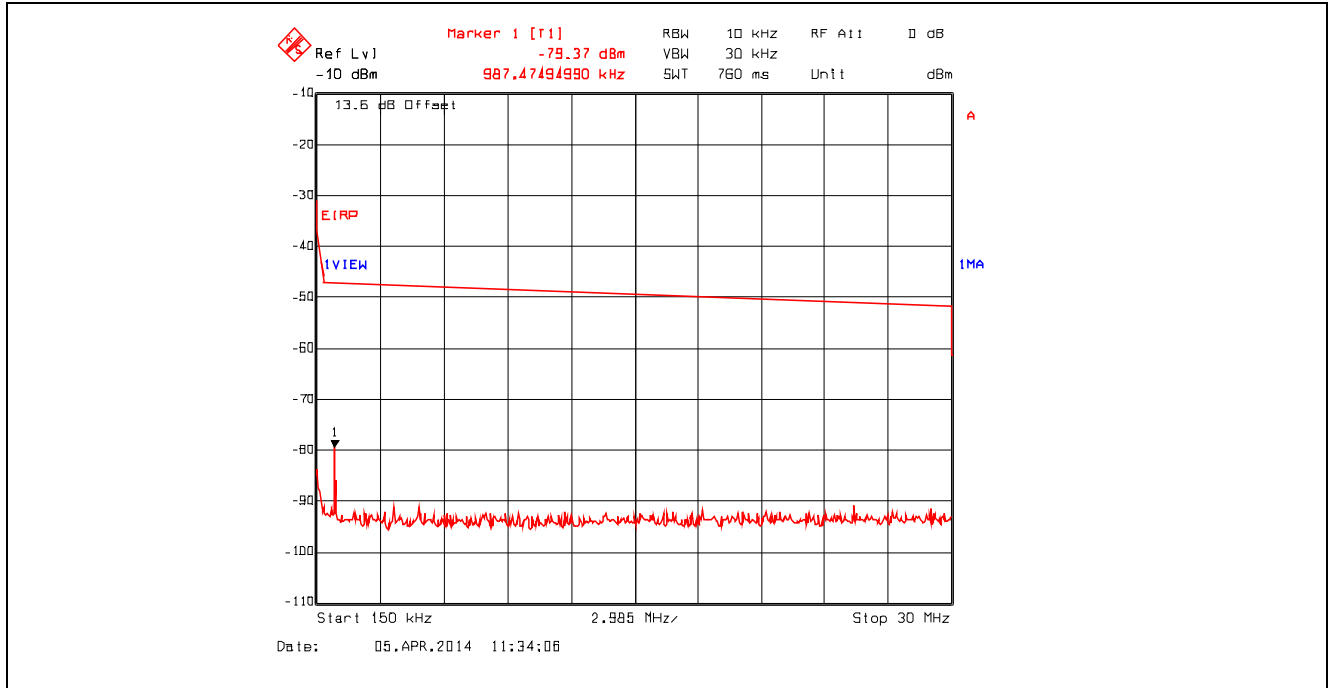

Plot 5.4.4.3.38. Conducted Spurious Emissions – Restricted Bands, Bands
 802.11n, 6.5 Mbps, 2437 MHz, 30 MHz - 1 GHz, Peak Detector with Band (Notch) Reject Filter

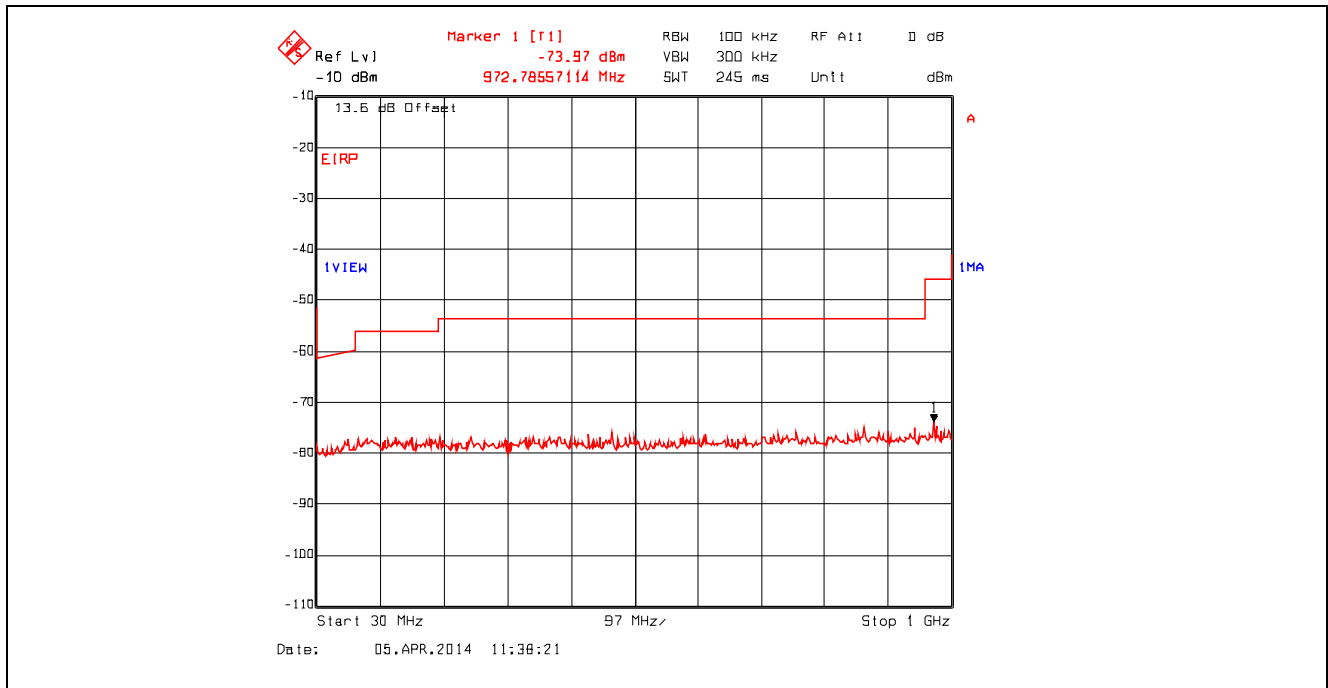

Plot 5.4.4.3.39. Conducted Spurious Emissions – Restricted Bands
 802.11n, 6.5 Mbps, 2437 MHz, 1 GHz - 4 GHz, RMS Detector with Band (Notch) Reject Filter

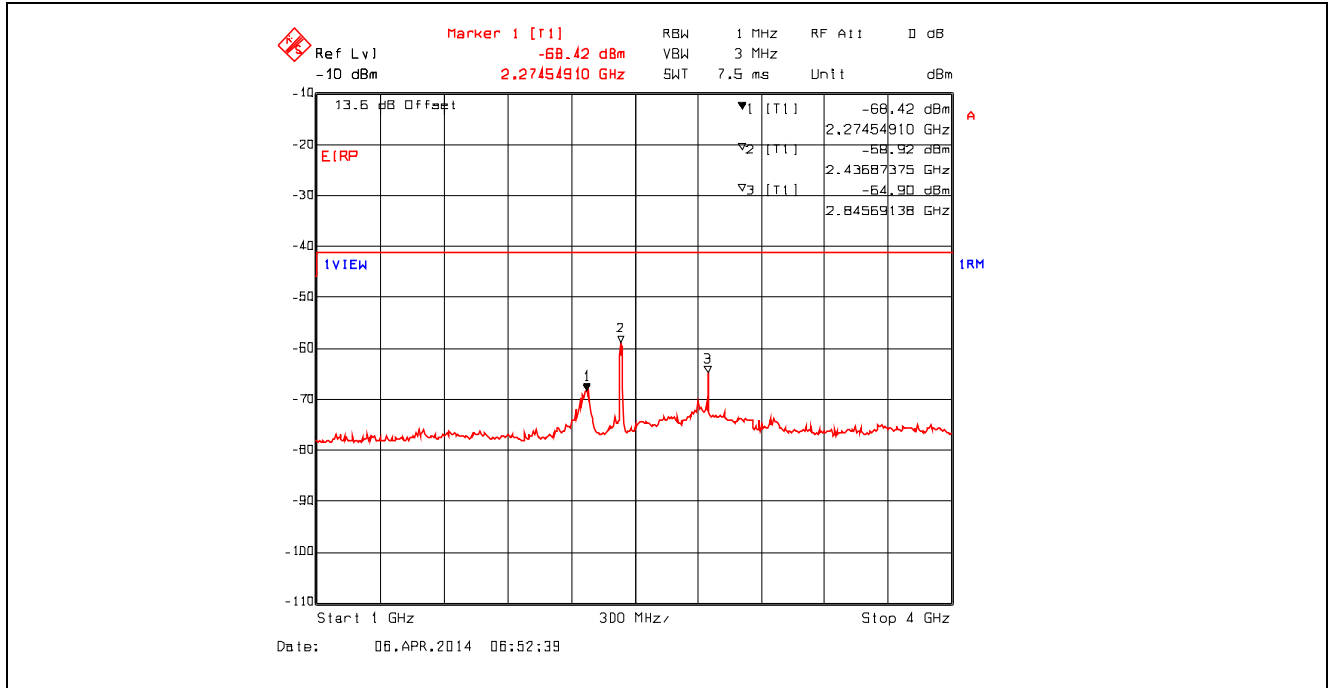

Plot 5.4.4.3.40. Conducted Spurious Emissions – Restricted Bands
 802.11n, 6.5 Mbps, 2437 MHz, 4 GHz - 25 GHz, RMS Detector with High Pass Filter

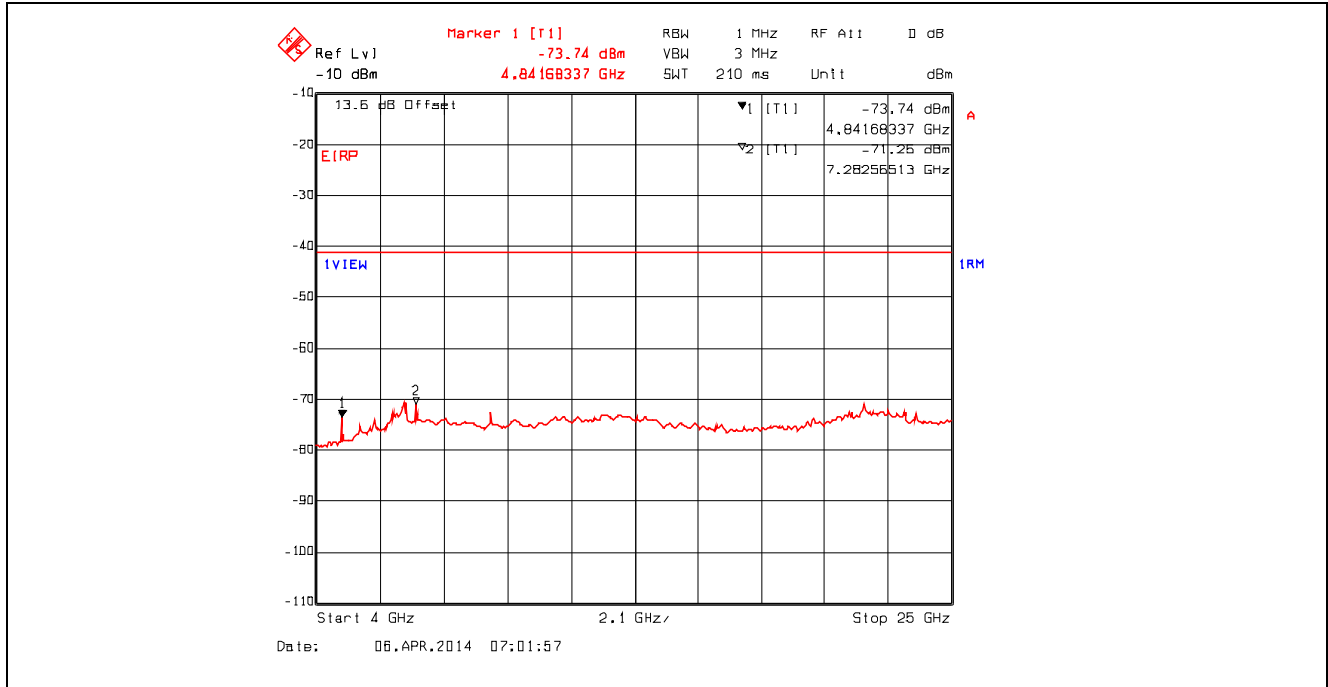

Plot 5.4.4.3.41. Conducted Spurious Emissions – Restricted Bands
 802.11n, 6.5 Mbps, 2462 MHz, 9 kHz - 150 kHz, Peak Detector with Band (Notch) Reject Filter

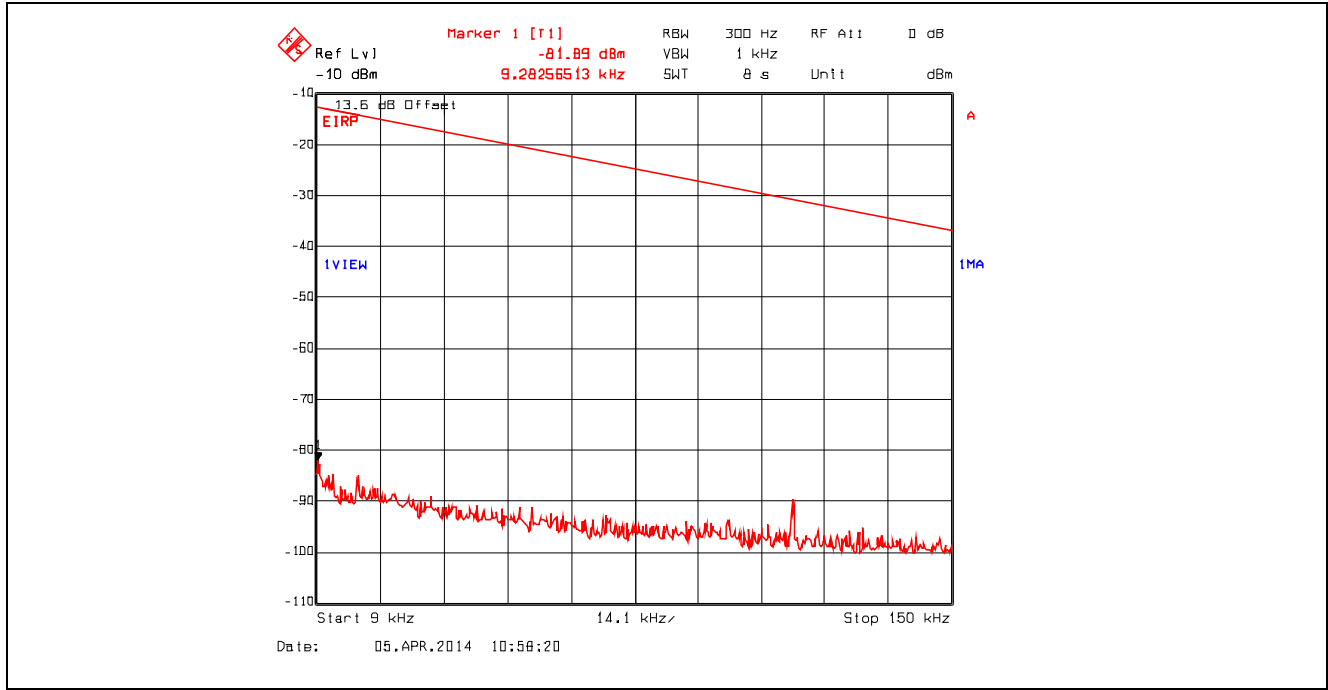

Plot 5.4.4.3.42. Conducted Spurious Emissions – Restricted Bands
 802.11n, 6.5 Mbps, 2462 MHz, 150 kHz - 30 MHz, Peak Detector with Band (Notch) Reject Filter

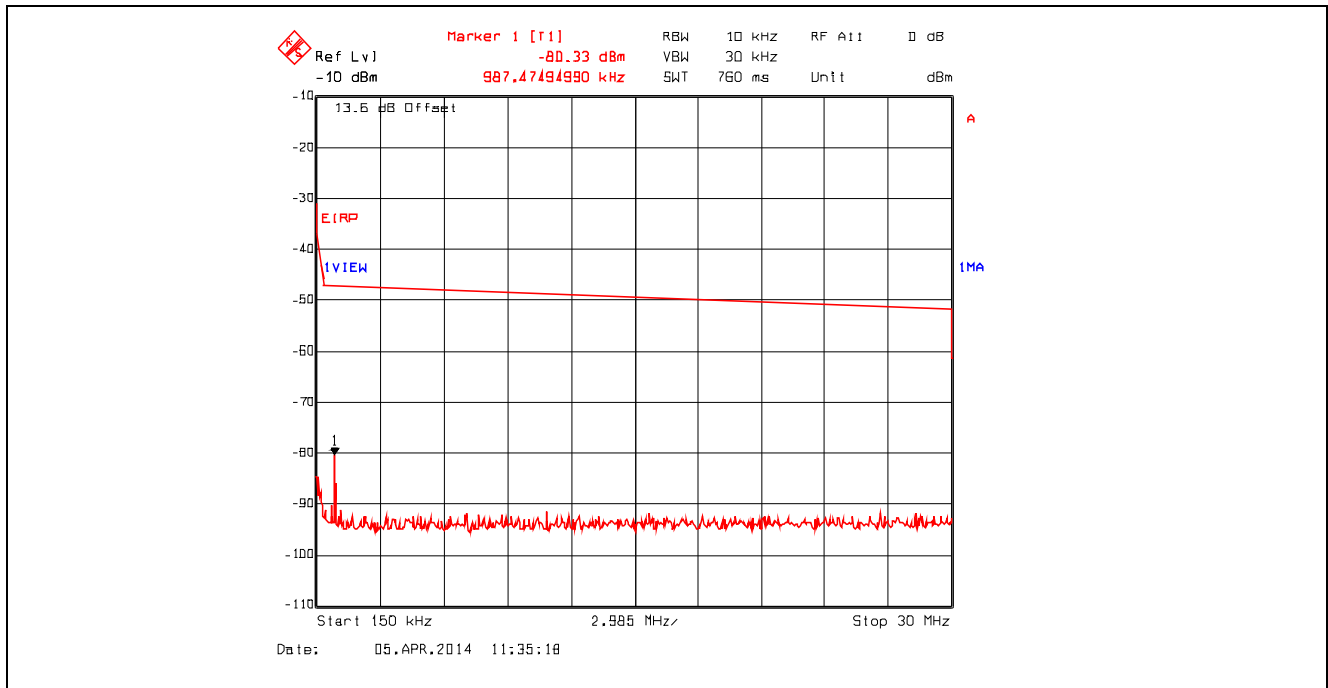

Plot 5.4.4.3.3. Conducted Spurious Emissions – Restricted Bands
 802.11n, 6.5 Mbps, 2462 MHz, 30 MHz - 1 GHz, Peak Detector with Band (Notch) Reject Filter

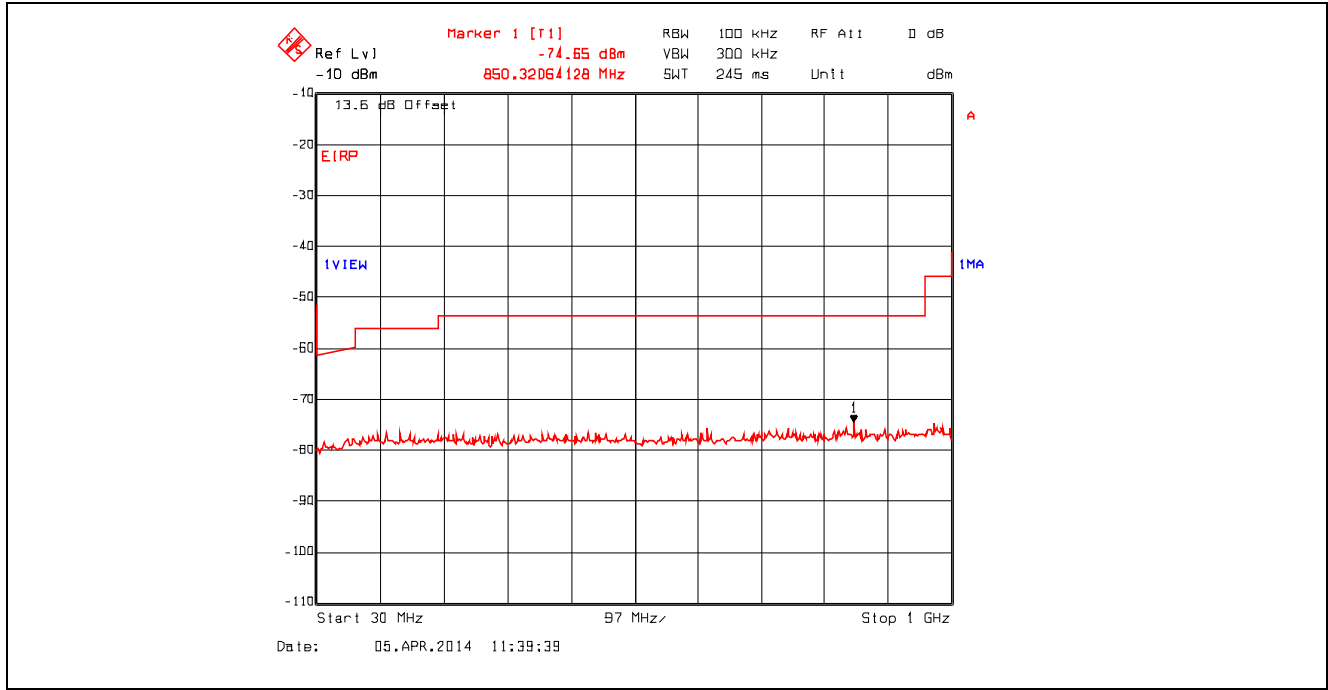

Plot 5.4.4.3.4. Conducted Spurious Emissions – Restricted Bands
 802.11n, 6.5 Mbps, 2462 MHz, 1 GHz - 4 GHz, RMS Detector with Band (Notch) Reject Filter

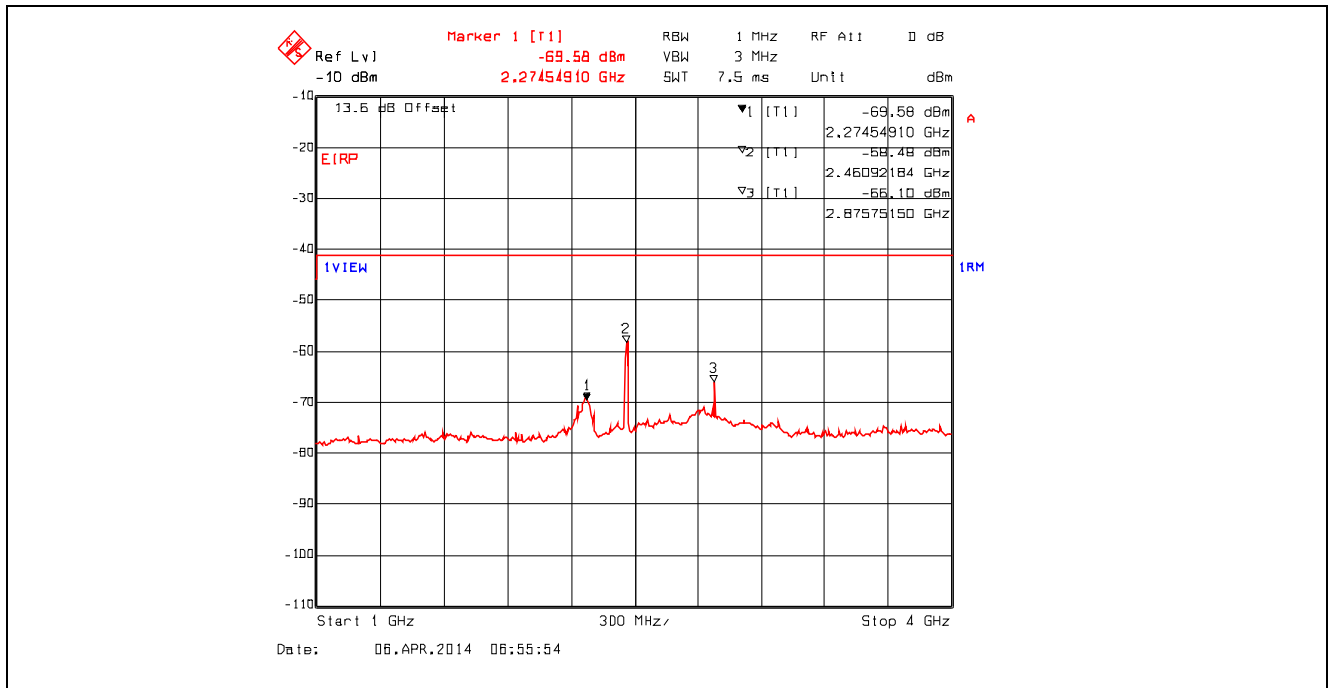

Plot 5.4.4.3.45. Conducted Spurious Emissions – Restricted Bands
 802.11n, 6.5 Mbps, 2462 MHz, 4 GHz - 25 GHz, RMS Detector with High Pass Filter

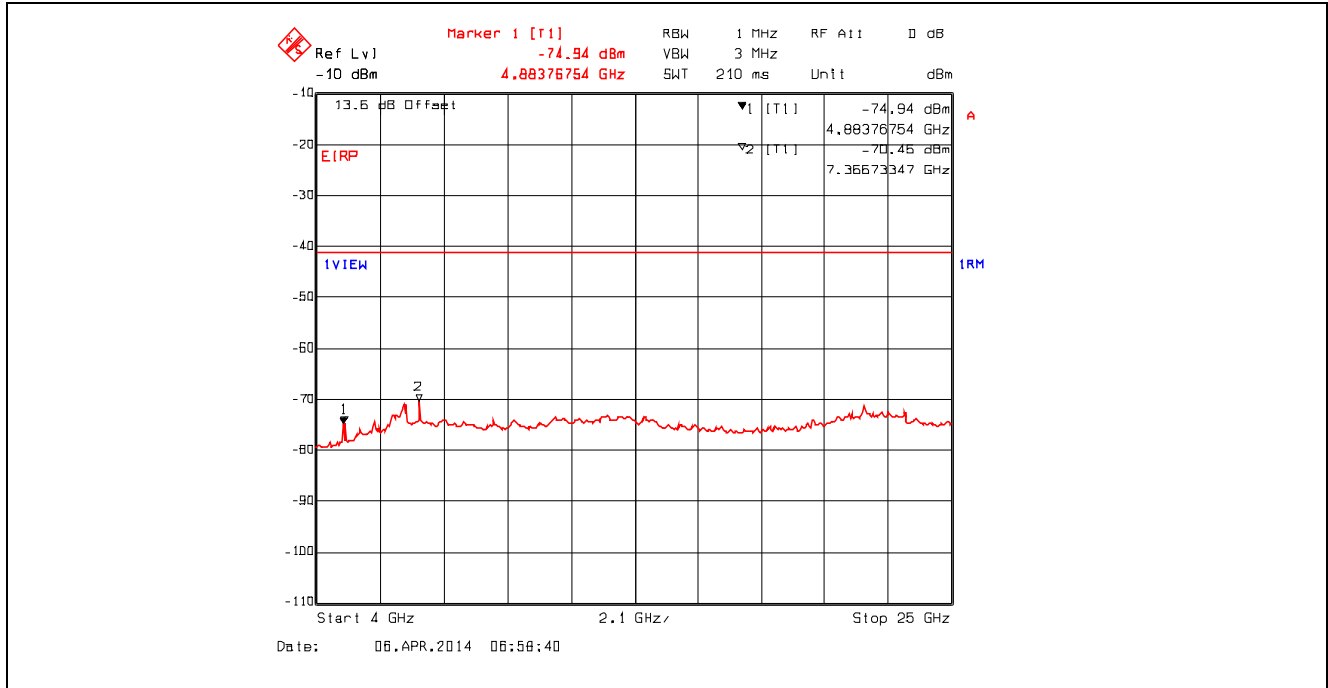

5.5. TRANSMITTER SPURIOUS RADIATED EMISSIONS AT 3 METERS [§§ 15.247(d), 15.209 & 15.205]

5.5.1. Limit(s)

§ 15.247 (d): In any 100 kHz bandwidth outside the frequency band in which the spread spectrum or digitally modulated intentional radiator is operating, the radio frequency power that is produced by the intentional radiator shall be at least 20 dB below that in the 100 kHz bandwidth within the band that contains the highest level of the desired power, based on either an RF conducted or a radiated measurement, provided the transmitter demonstrates compliance with the peak conducted power limits. If the transmitter complies with the conducted power limits based on the use of RMS averaging over a time interval, as permitted under paragraph (b)(3) of this section, the attenuation required under this paragraph shall be 30 dB instead of 20 dB. Attenuation below the general limits specified in Section 15.209(a) is not required. In addition, radiated emissions which fall in the restricted bands, as defined in Section 15.205(a), must also comply with the radiated emission limits specified in Section 15.209(a) (see Section 15.205(c)).

Section 15.205(a) - Restricted Bands of Operation

MHz	MHz	MHz	GHz
0.090–0.110	16.42–16.423	399.9–410	4.5–5.15
¹ 0.495–0.505	16.69475–16.69525	608–614	5.35–5.46
2.1735–2.1905	16.80425–16.80475	960–1240	7.25–7.75
4.125–4.128	25.5–25.67	1300–1427	8.025–8.5
4.17725–4.17775	37.5–38.25	1435–1626.5	9.0–9.2
4.20725–4.20775	73–74.6	1645.5–1646.5	9.3–9.5
6.215–6.218	74.8–75.2	1660–1710	10.6–12.7
6.26775–6.26825	108–121.94	1718.8–1722.2	13.25–13.4
6.31175–6.31225	123–138	2200–2300	14.47–14.5
8.291–8.294	149.9–150.05	2310–2390	15.35–16.2
8.362–8.366	156.52475–156.52525	2483.5–2500	17.7–21.4
8.37625–8.38675	156.7–156.9	2655–2900	22.01–23.12
8.41425–8.41475	162.0125–167.17	3260–3267	23.6–24.0
12.29–12.293	167.72–173.2	3332–3339	31.2–31.8
12.51975–12.52025	240–285	3345.8–3358	36.43–36.5
12.57675–12.57725	322–335.4	3600–4400	(²)
13.36–13.41			

¹ Until February 1, 1999, this restricted band shall be 0.490–0.510 MHz.
² Above 38.6

Section 15.209(a)
-- Field Strength Limits within Restricted Frequency Bands --

Frequency (MHz)	Field Strength (microvolts/meter)	Measurement Distance (meters)
0.009 - 0.490	2,400 / F (kHz)	300
0.490 - 1.705	24,000 / F (kHz)	30
1.705 - 30.0	30	30
30 - 88	100	3
88 - 216	150	3
216 - 960	200	3
Above 960	500	3

5.5.2. Method of Measurements

KDB Publication No. D01 DTS Meas Guidance v03r01, Section 12.2.7 and ANSI C63.10.

5.5.3. Test Arrangement

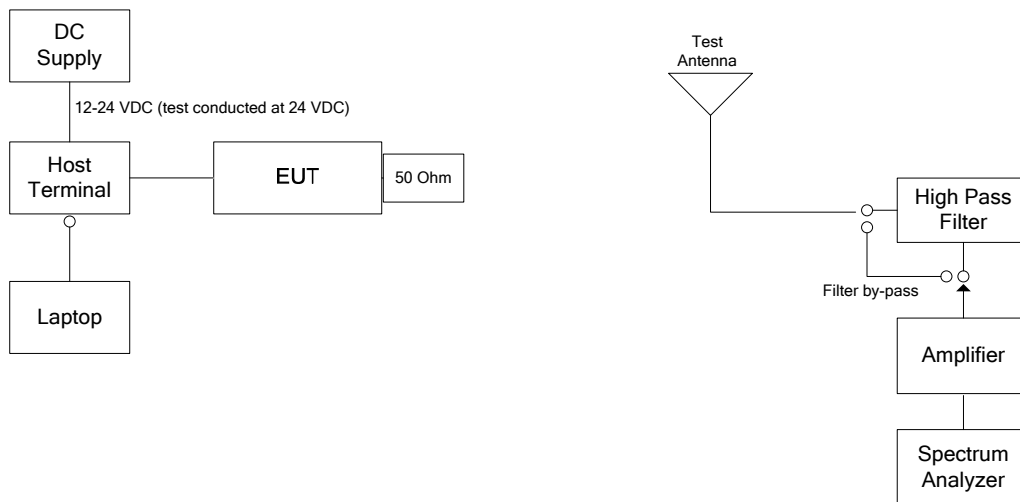

5.5.4. Test Data

Remark(s):

- All spurious emissions that are in excess of 20 dB below the specified limit shall be recorded.
- EUT shall be tested in three orthogonal positions.
- § 15.247 (d) spurious emission limit: $E = (EIRP - 20\log(d) + 104.8) - 20 = (EIRP - 20\log(3) + 104.8) - 20$

5.5.4.1. 802.11b Mode, 1 Mbps DBPSK

Fundamental Frequency:		2412 MHz					
Output Power:		24.42 dBm EIRP Max.					
Frequency Test Range		30 MHz – 25 GHz					
Frequency (MHz)	RF Peak Level (dBµV/m)	RF Avg Level (dBµV/m)	Antenna Plane (H/V)	Limit 15.209 (dBµV/m)	Limit 15.247 (dBµV/m)	Margin (dB)	Pass/Fail
4824	50.19	37.23	V	54.0	99.7	-16.8	Pass*
4824	50.19	38.27	H	54.0	99.7	-15.7	Pass*
12060	61.45	52.62	V	54.0	99.7	-1.4	Pass*
12060	58.11	46.31	H	54.0	99.7	-7.7	Pass*
14472	59.08	50.60	V	54.0	99.7	-3.4	Pass*
14472	58.01	46.35	H	54.0	99.7	-7.7	Pass*
*Emission within the restricted bands, limits in section 15.209 applied.							

Fundamental Frequency:		2437 MHz					
Output Power:		24.01 dBm EIRP Max.					
Frequency Test Range		30 MHz – 25 GHz					
Frequency (MHz)	RF Peak Level (dBµV/m)	RF Avg Level (dBµV/m)	Antenna Plane (H/V)	Limit 15.209 (dBµV/m)	Limit 15.247 (dBµV/m)	Margin (dB)	Pass/Fail
4874	46.83	36.64	V	54.0	99.3	-17.4	Pass*
4874	48.27	40.99	H	54.0	99.3	-13.0	Pass*
7311	58.35	51.84	V	54.0	99.3	-2.2	Pass*
7311	56.80	48.65	H	54.0	99.3	-5.4	Pass*
12185	61.55	52.87	V	54.0	99.3	-1.1	Pass*
12185	58.16	49.60	H	54.0	99.3	-4.4	Pass*
*Emission within the restricted bands, limits in section 15.209 applied.							

Fundamental Frequency:		2462 MHz					
Output Power:		23.75 dBm EIRP Max.					
Frequency Test Range:		30 MHz – 25 GHz					
Frequency (MHz)	RF Peak Level (dBµV/m)	RF Avg Level (dBµV/m)	Antenna Plane (H/V)	Limit 15.209 (dBµV/m)	Limit 15.247 (dBµV/m)	Margin (dB)	Pass/Fail
4924	45.81	35.59	V	54.0	99.0	-18.4	Pass*
7386	58.34	51.60	V	54.0	99.0	-2.4	Pass*
12310	60.71	51.68	V	54.0	99.0	-2.3	Pass*
4924	48.39	38.37	H	54.0	99.0	-15.6	Pass*
7386	57.48	50.27	H	54.0	99.0	-3.7	Pass*
12310	61.20	51.64	H	54.0	99.0	-2.4	Pass*
*Emission within the restricted bands, limits in section 15.209 applied.							

5.5.4.2. 802.11g Mode, 9 Mbps BPSK

Fundamental Frequency:		2412 MHz					
Output Power:		25.87 dBm EIRP Max.					
Frequency Test Range		30 MHz – 25 GHz					
Frequency (MHz)	RF Peak Level (dBµV/m)	RF Avg Level (dBµV/m)	Antenna Plane (H/V)	Limit 15.209 (dBµV/m)	Limit 15.247 (dBµV/m)	Margin (dB)	Pass/Fail
12060	56.05	44.10	V	54.0	101.1	-9.9	Pass*
12060	56.42	44.53	H	54.0	101.1	-9.5	Pass*
*Emission within the restricted bands, limits in section 15.209 applied.							

Fundamental Frequency:		2437 MHz					
Output Power:		25.32 dBm EIRP Max.					
Frequency Test Range		30 MHz – 25 GHz					
Frequency (MHz)	RF Peak Level (dBµV/m)	RF Avg Level (dBµV/m)	Antenna Plane (H/V)	Limit 15.209 (dBµV/m)	Limit 15.247 (dBµV/m)	Margin (dB)	Pass/Fail
7311	58.36	42.37	V	54.0	100.6	-11.6	Pass*
7311	59.20	42.61	H	54.0	100.6	-11.4	Pass*
12185	57.24	44.74	V	54.0	100.6	-9.3	Pass*
12185	56.59	44.65	H	54.0	100.6	-9.4	Pass*
*Emission within the restricted bands, limits in section 15.209 applied.							

Fundamental Frequency:		2462 MHz					
Output Power:		24.73 dBm EIRP Max.					
Frequency Test Range:		30 MHz – 25 GHz					
Frequency (MHz)	RF Peak Level (dBµV/m)	RF Avg Level (dBµV/m)	Antenna Plane (H/V)	Limit 15.209 (dBµV/m)	Limit 15.247 (dBµV/m)	Margin (dB)	Pass/Fail
7386	58.33	43.35	V	54.0	100.0	-10.7	Pass*
7386	59.19	43.87	H	54.0	100.0	-10.1	Pass*
12310	62.46	45.52	V	54.0	100.0	-8.5	Pass*
12310	62.09	45.90	H	54.0	100.0	-8.1	Pass*
*Emission within the restricted bands, limits in section 15.209 applied.							

5.5.4.3. 802.11n 800ns Mode, 6.5 Mbps BPSK 1/2

Fundamental Frequency:		2412 MHz					
Output Power:		25.87 dBm EIRP Max.					
Frequency Test Range		30 MHz – 25 GHz					
Frequency (MHz)	RF Peak Level (dBµV/m)	RF Avg Level (dBµV/m)	Antenna Plane (H/V)	Limit 15.209 (dBµV/m)	Limit 15.247 (dBµV/m)	Margin (dB)	Pass/Fail
12060	55.92	43.96	V	54.0	101.1	-10.0	Pass*
12060	56.77	44.67	H	54.0	101.1	-9.3	Pass*
*Emission within the restricted bands, limits in section 15.209 applied.							

Fundamental Frequency:		2437 MHz					
Output Power:		25.25 dBm EIRP Max.					
Frequency Test Range		30 MHz – 25 GHz					
Frequency (MHz)	RF Peak Level (dBµV/m)	RF Avg Level (dBµV/m)	Antenna Plane (H/V)	Limit 15.209 (dBµV/m)	Limit 15.247 (dBµV/m)	Margin (dB)	Pass/Fail
7311	58.95	42.97	V	54.0	100.5	-11.0	Pass*
7311	56.56	41.97	H	54.0	100.5	-12.0	Pass*
12185	58.21	44.37	V	54.0	100.5	-9.6	Pass*
12185	58.71	44.75	H	54.0	100.5	-9.3	Pass*
*Emission within the restricted bands, limits in section 15.209 applied.							

Fundamental Frequency:		2462 MHz					
Output Power:		24.57 dBm EIRP Max.					
Frequency Test Range:		30 MHz – 25 GHz					
Frequency (MHz)	RF Peak Level (dBµV/m)	RF Avg Level (dBµV/m)	Antenna Plane (H/V)	Limit 15.209 (dBµV/m)	Limit 15.247 (dBµV/m)	Margin (dB)	Pass/Fail
7386	58.32	43.46	V	54.0	99.8	-10.5	Pass*
12310	60.99	45.92	V	54.0	99.8	-8.1	Pass*
7386	58.89	43.47	H	54.0	99.8	-10.5	Pass*
12310	60.94	46.10	H	54.0	99.8	-7.9	Pass*
*Emission within the restricted bands, limits in section 15.209 applied.							

5.6. POWER SPECTRAL DENSITY [§ 15.247(e)]

5.6.1. Limit(s)

For digitally modulated systems, the power spectral density conducted from the intentional radiator to the antenna shall not be greater than 8 dBm in any 3 kHz band during any time interval of continuous transmission.

5.6.2. Method of Measurements

Publication No. KDB Publication No. 558074 D01 DTS Meas Guidance V03r01, Section 10.2 Method PKPSD

5.6.3. Test Arrangement

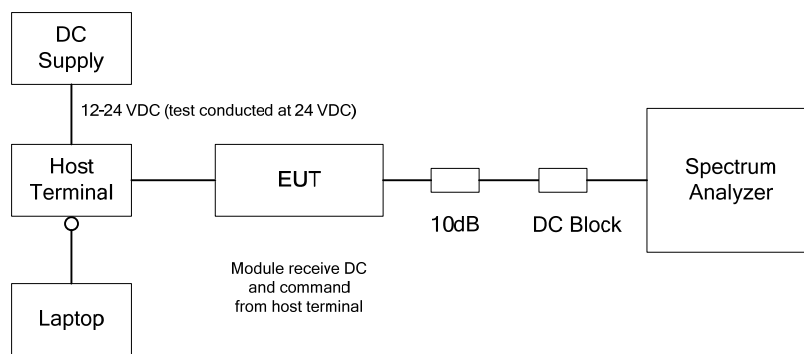

5.6.4. Test Data

Remark: Measurement method: Section 10.2 Method PKPSD (peak PSD)

Operating Mode	Modulation	Frequency (MHz)	*PSD in 3 kHz BW (dBm)	Limit (dBm)	Margin (dB)
802.11b	1 Mbps DBPSK	2412	-2.74	8	-10.74
		2437	-1.84	8	-9.84
		2462	-2.84	8	-10.84
	2 Mbps DQPSK	2412	-3.21	8	-11.21
		2437	-3.98	8	-11.98
		2462	-4.42	8	-12.42
	11 Mbps CCK	2412	-4.68	8	-12.68
		2437	-4.12	8	-12.12
		2462	-4.02	8	-12.02

Operating Mode	Modulation	Frequency (MHz)	*PSD in 3 kHz BW (dBm)	Limit (dBm)	Margin (dB)
802.11g	9 Mbps BPSK	2412	-5.93	8	-13.93
		2437	-7.65	8	-15.65
		2462	-7.51	8	-15.51
	18 Mbps QPSK	2412	-6.53	8	-14.53
		2437	-7.64	8	-15.64
		2462	-7.76	8	-15.76
	36 Mbps 16-QAM	2412	-8.93	8	-16.93
		2437	-9.50	8	-17.50
		2462	-9.50	8	-17.50
	54 Mbps 64-QAM	2412	-10.42	8	-18.42
		2437	-10.50	8	-18.50
		2462	-11.20	8	-19.20
802.11n 800ns	6.5 Mbps BPSK 1/2	2412	-5.57	8	-13.57
		2437	-6.83	8	-14.83
		2462	-7.34	8	-15.34
	19.5 Mbps QPSK 3/4	2412	-6.76	8	-14.76
		2437	-7.11	8	-15.11
		2462	-7.58	8	-15.58
	39 Mbps 16-QAM 3/4	2412	-9.00	8	-17.00
		2437	-9.80	8	-17.80
		2462	-9.25	8	-17.25
	65 Mbps 64-QAM 5/6	2412	-10.01	8	-18.01
		2437	-11.53	8	-19.53
		2462	-11.80	8	-19.80

*See the following plots for measurement details.

Plot 5.6.4.1. Power Spectral Density, 802.11b, 1 Mbps DBPSK, 2412 MHz

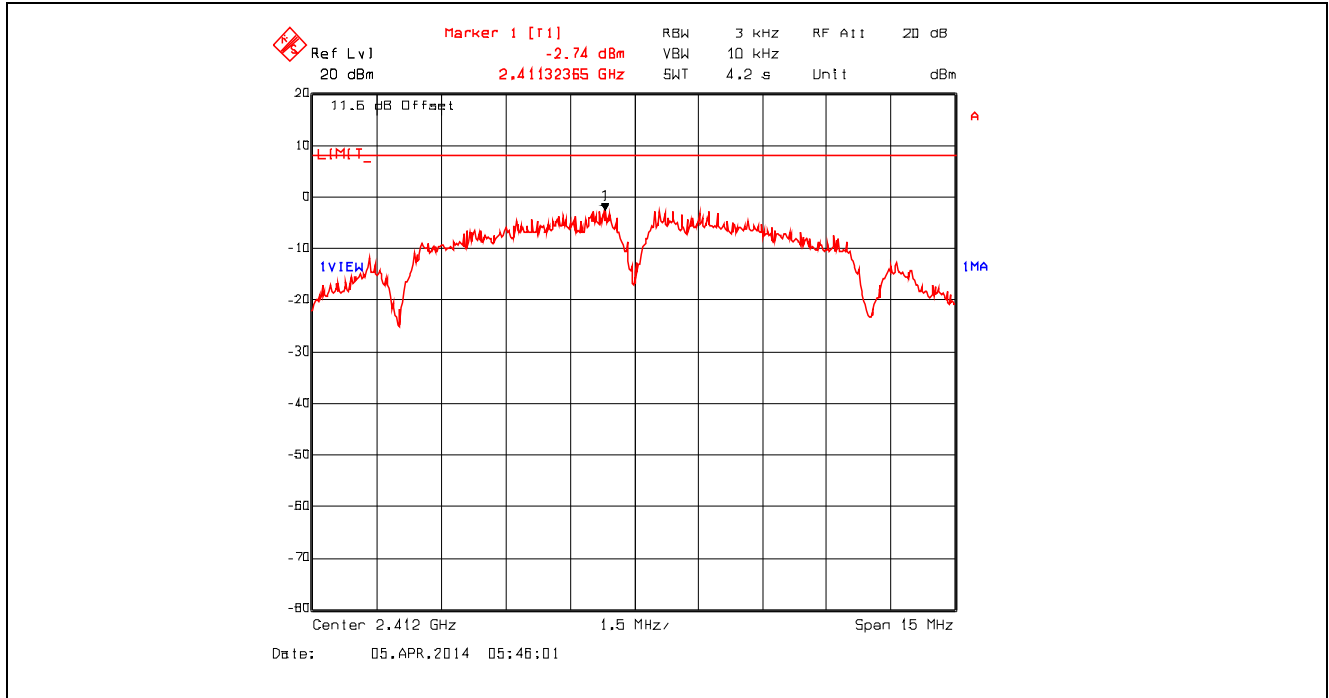

Plot 5.6.4.2. Power Spectral Density, 802.11b, 1 Mbps DBPSK, 2437 MHz

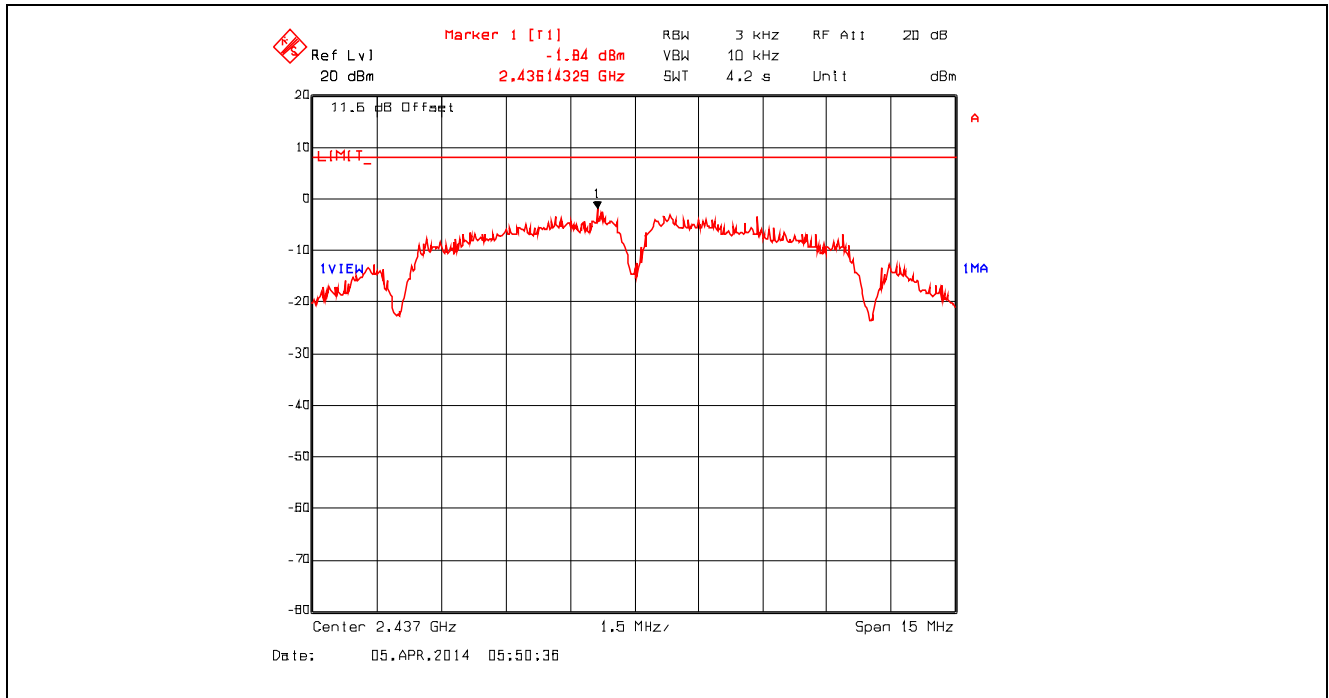

Plot 5.6.4.3. Power Spectral Density, 802.11b, 1 Mbps DBPSK, 2462 MHz

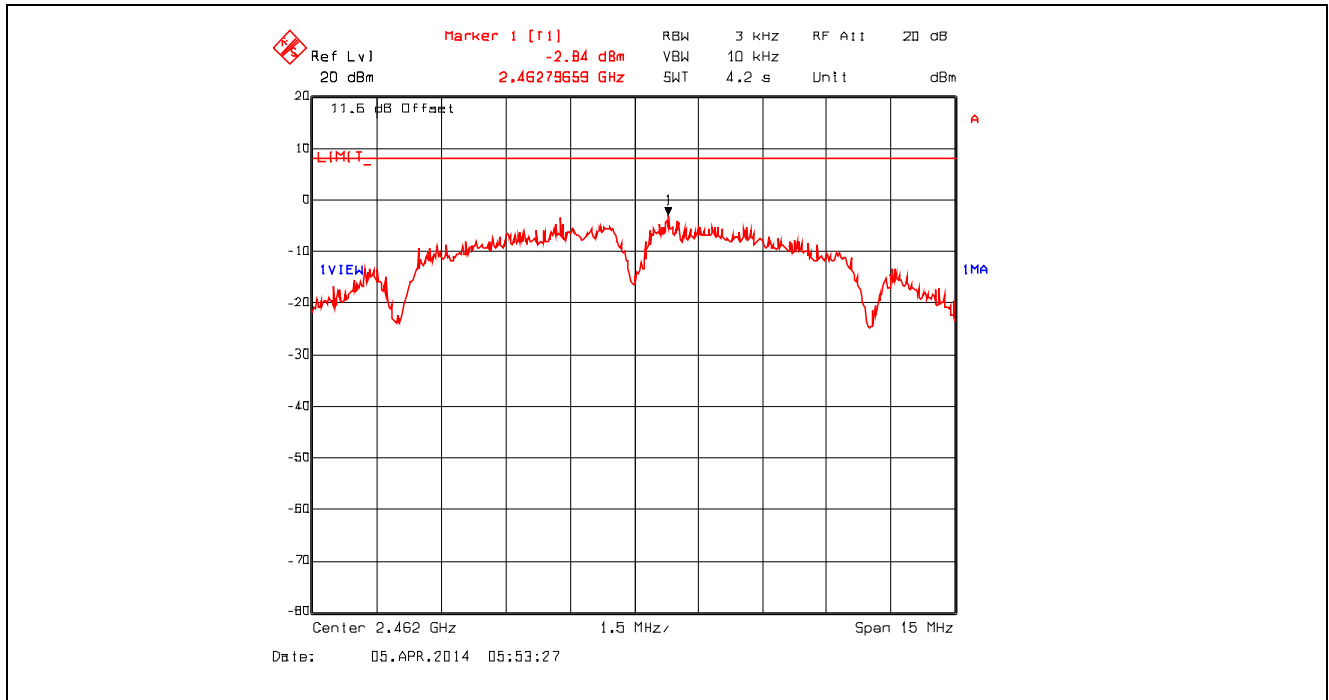

Plot 5.6.4.4. Power Spectral Density, 802.11b, 2 Mbps DQPSK, 2412 MHz

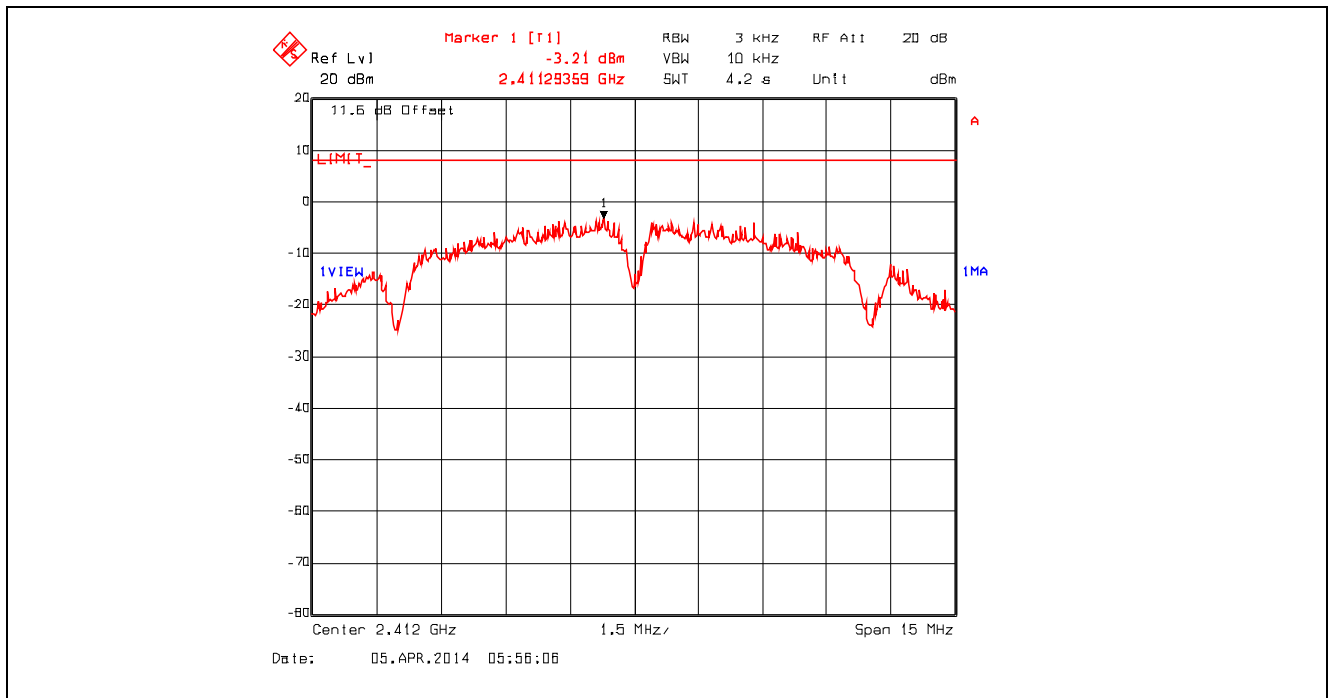

Plot 5.6.4.5. Power Spectral Density, 802.11b, 2 Mbps DQPSK, 2437 MHz

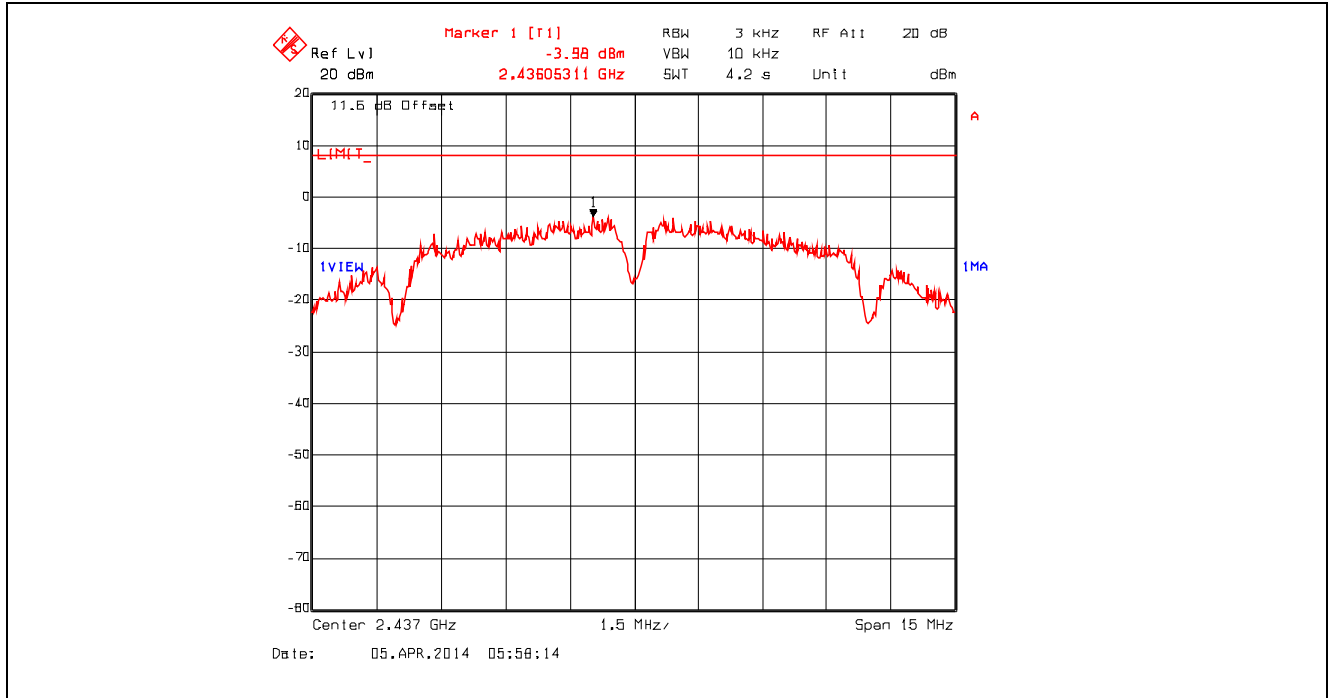

Plot 5.6.4.6. Power Spectral Density, 802.11b, 2 Mbps DQPSK, 2462 MHz

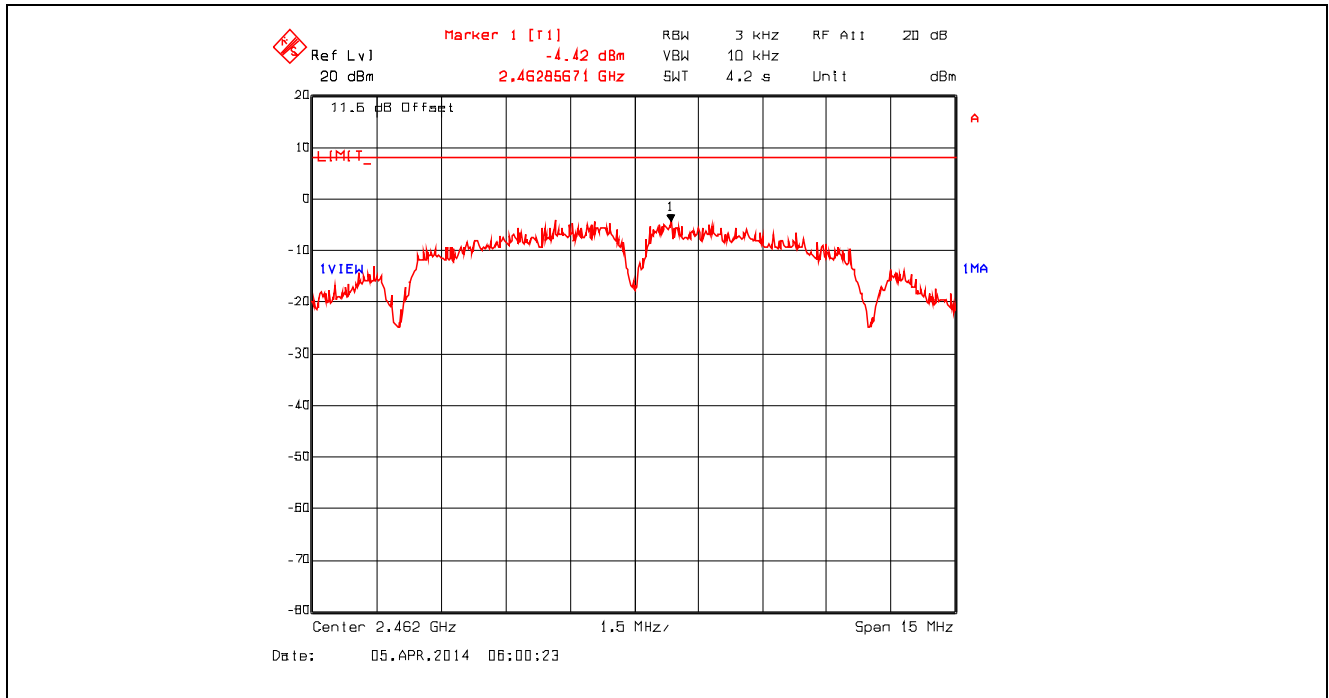

Plot 5.6.4.7. Power Spectral Density, 802.11b, 11 Mbps CCK, 2412 MHz

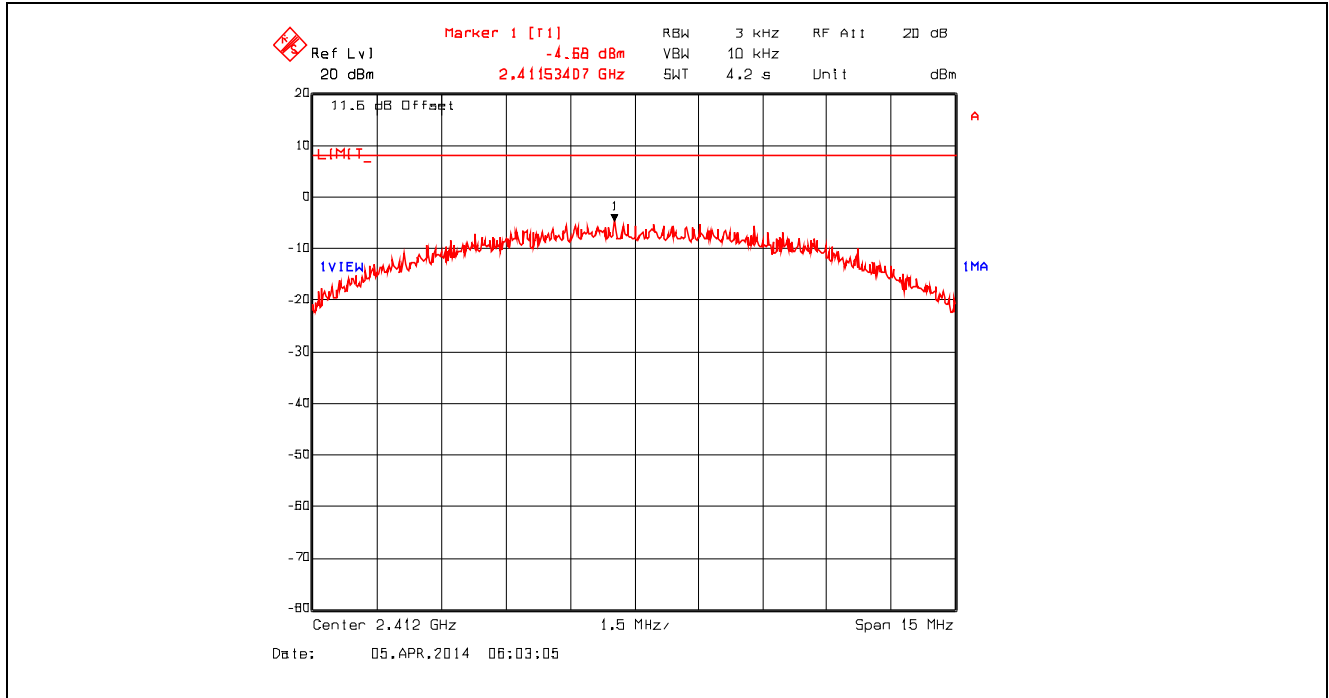

Plot 5.6.4.8. Power Spectral Density, 802.11b, 11 Mbps CCK, 2437 MHz

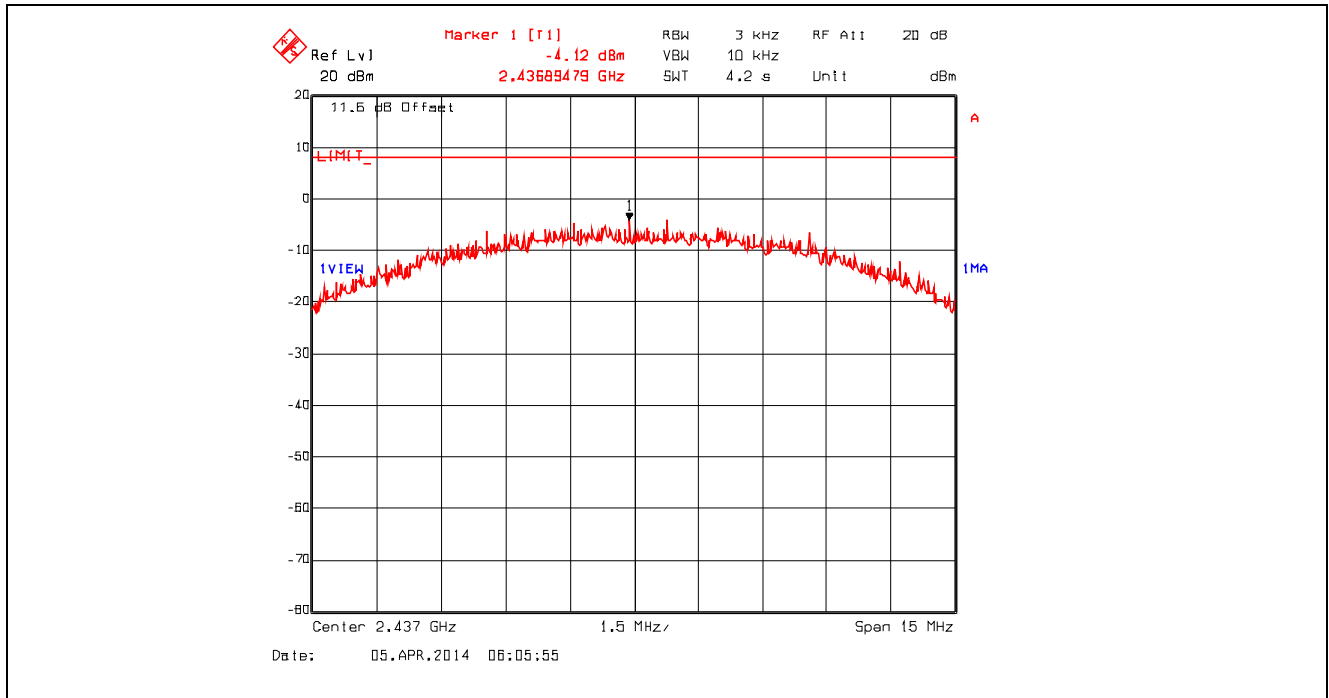

Plot 5.6.4.9. Power Spectral Density, 802.11b, 11 Mbps CCK, 2462 MHz

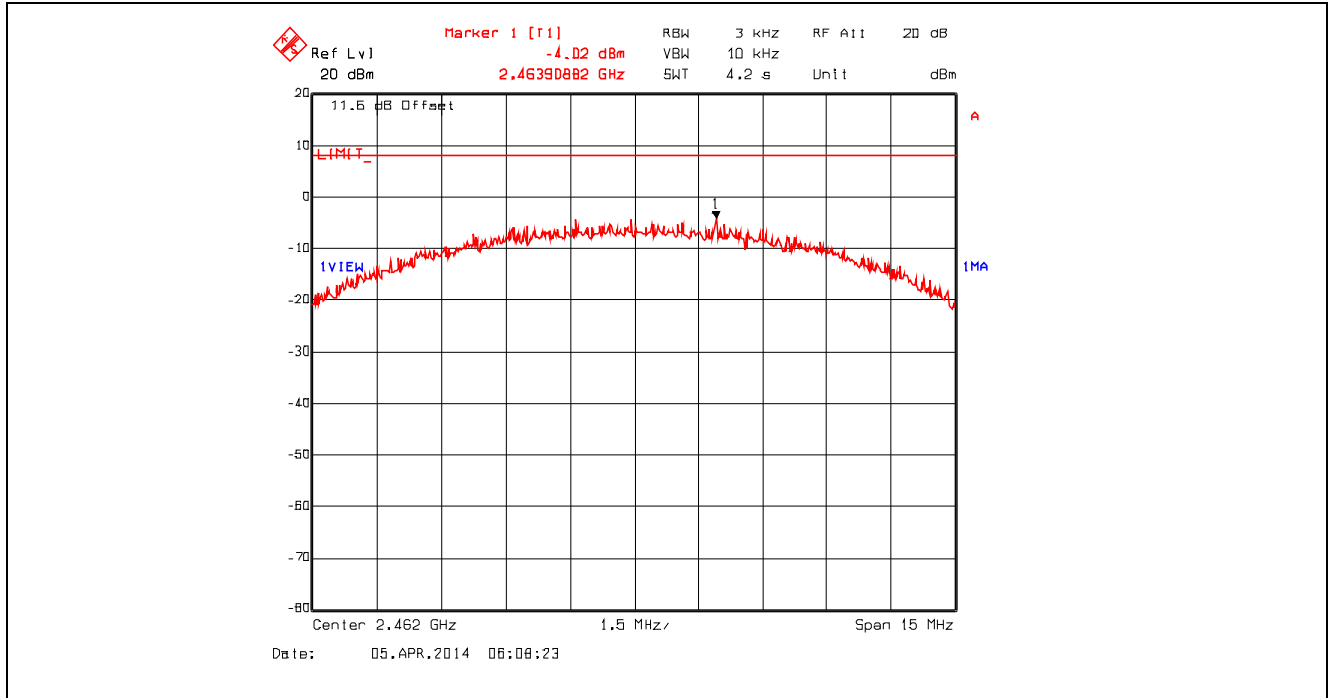

Plot 5.6.4.10. Power Spectral Density, 802.11g, 9 Mbps BPSK, 2412 MHz

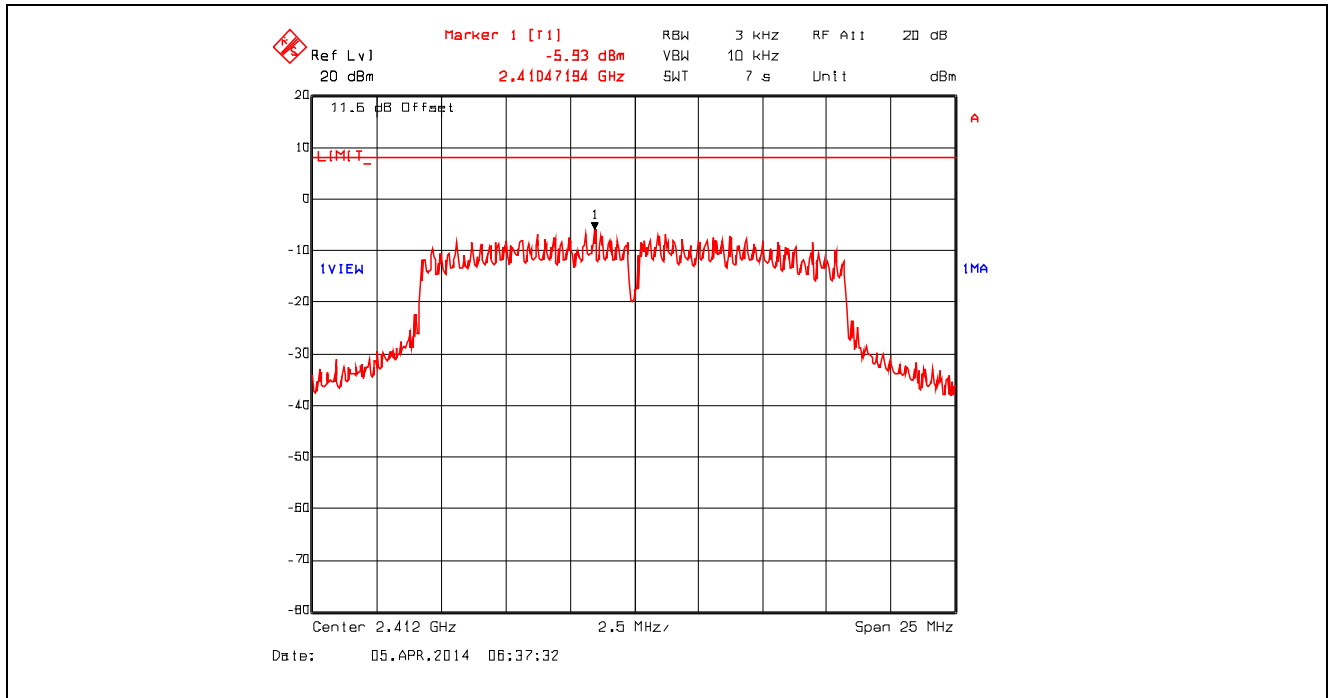

Plot 5.6.4.11. Power Spectral Density, 802.11g, 9 Mbps BPSK, 2437 MHz

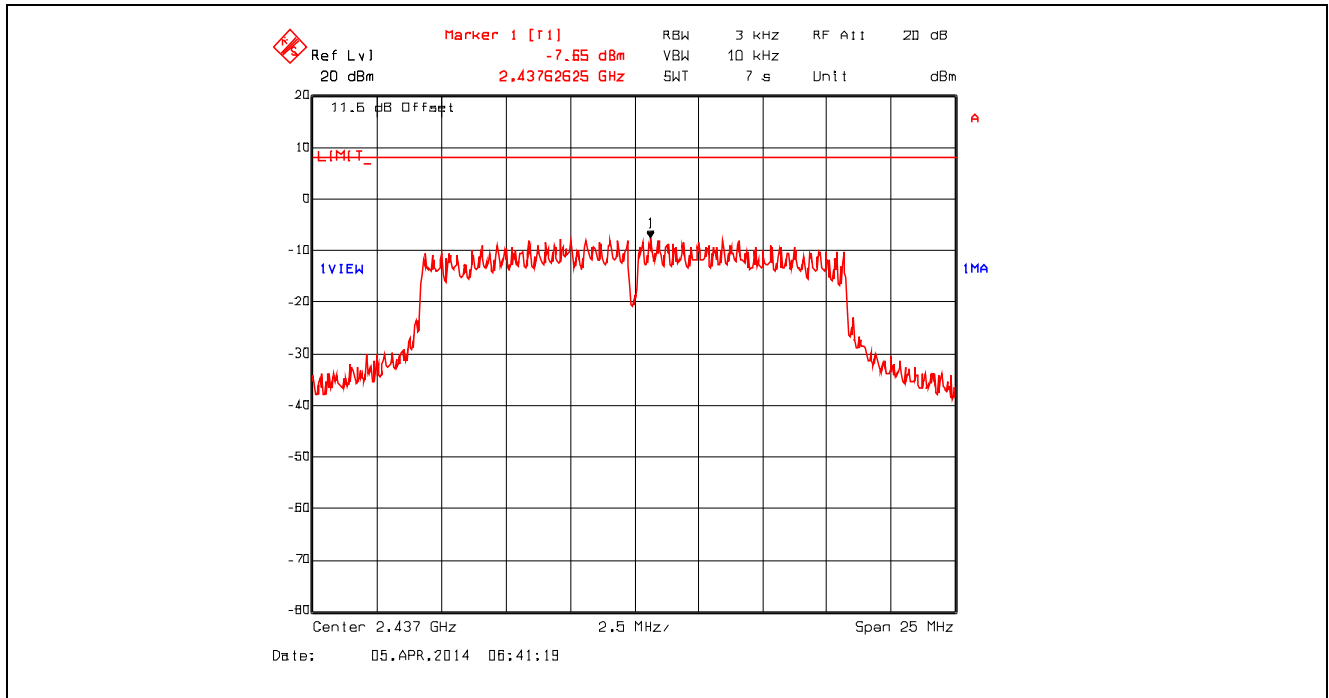

Plot 5.6.4.12. Power Spectral Density, 802.11g, 9 Mbps BPSK, 2462 MHz

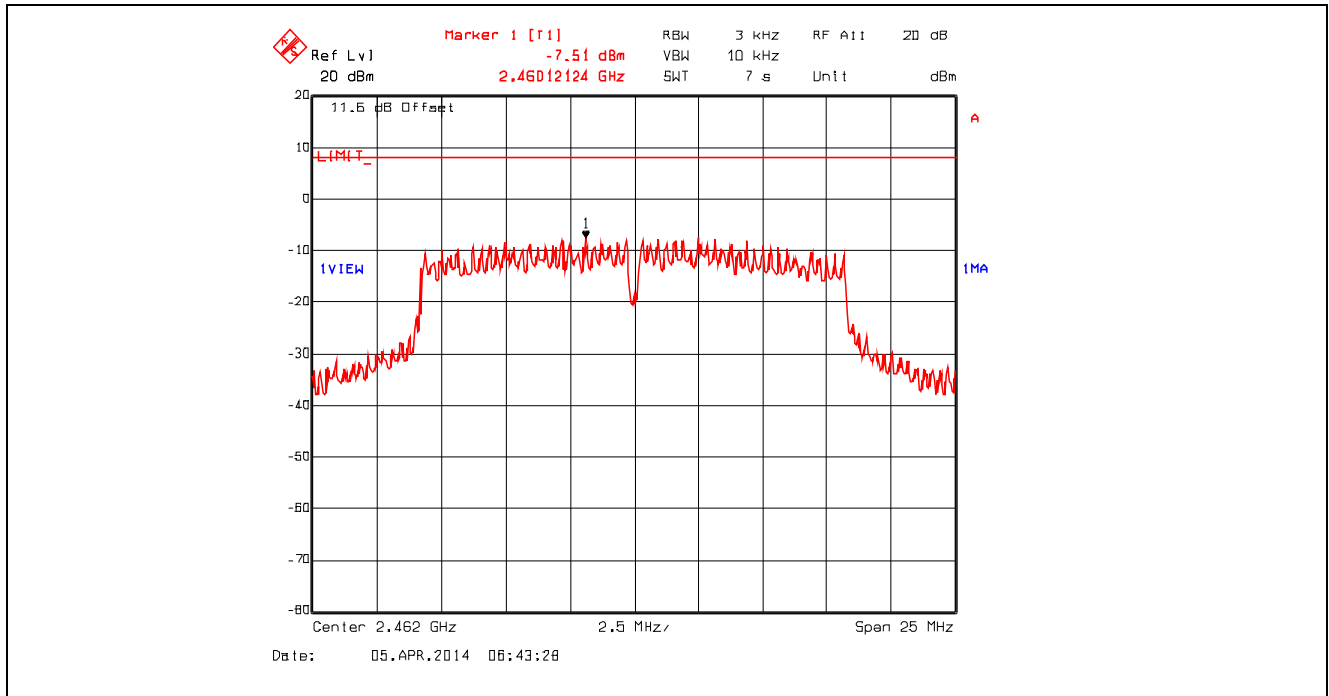

Plot 5.6.4.13. Power Spectral Density, 802.11g, 18 Mbps QPSK, 2412 MHz

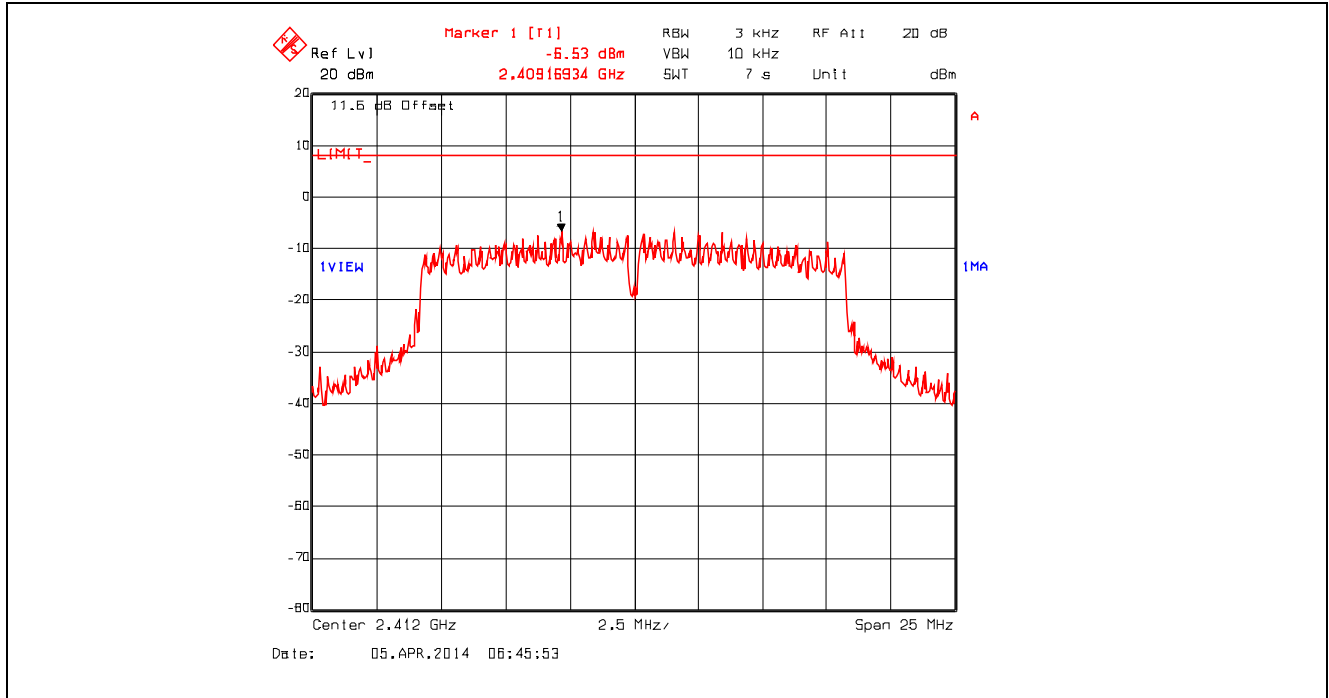

Plot 5.6.4.14. Power Spectral Density, 802.11g, 18 Mbps QPSK, 2437 MHz

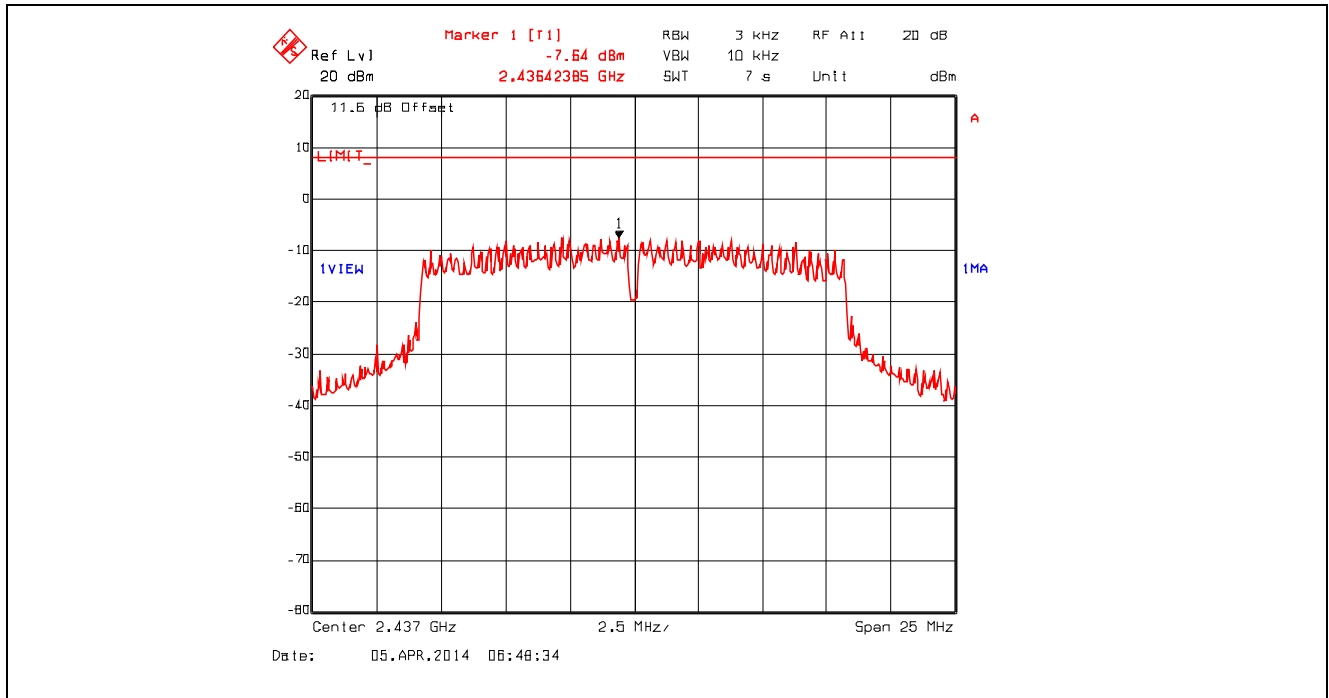

Plot 5.6.4.15. Power Spectral Density, 802.11g, 18 Mbps QPSK, 2462 MHz

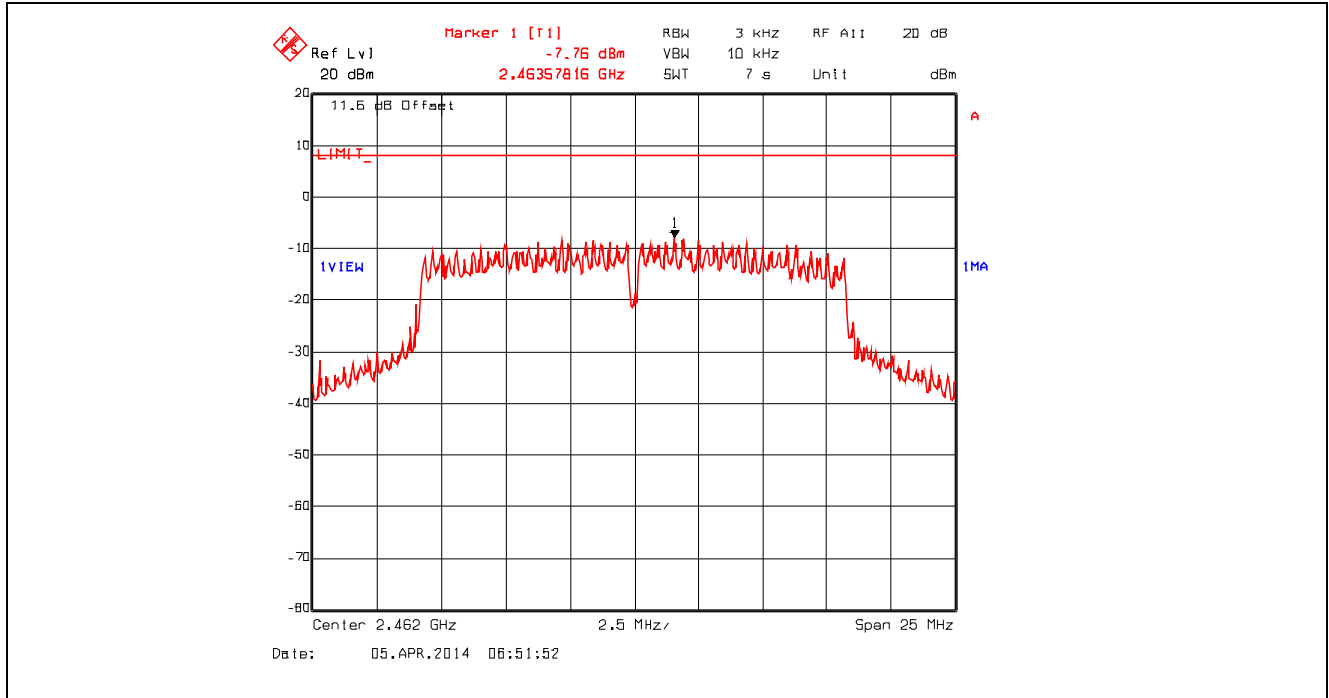

Plot 5.6.4.16. Power Spectral Density, 802.11g, 36 Mbps 16-QAM, 2412 MHz

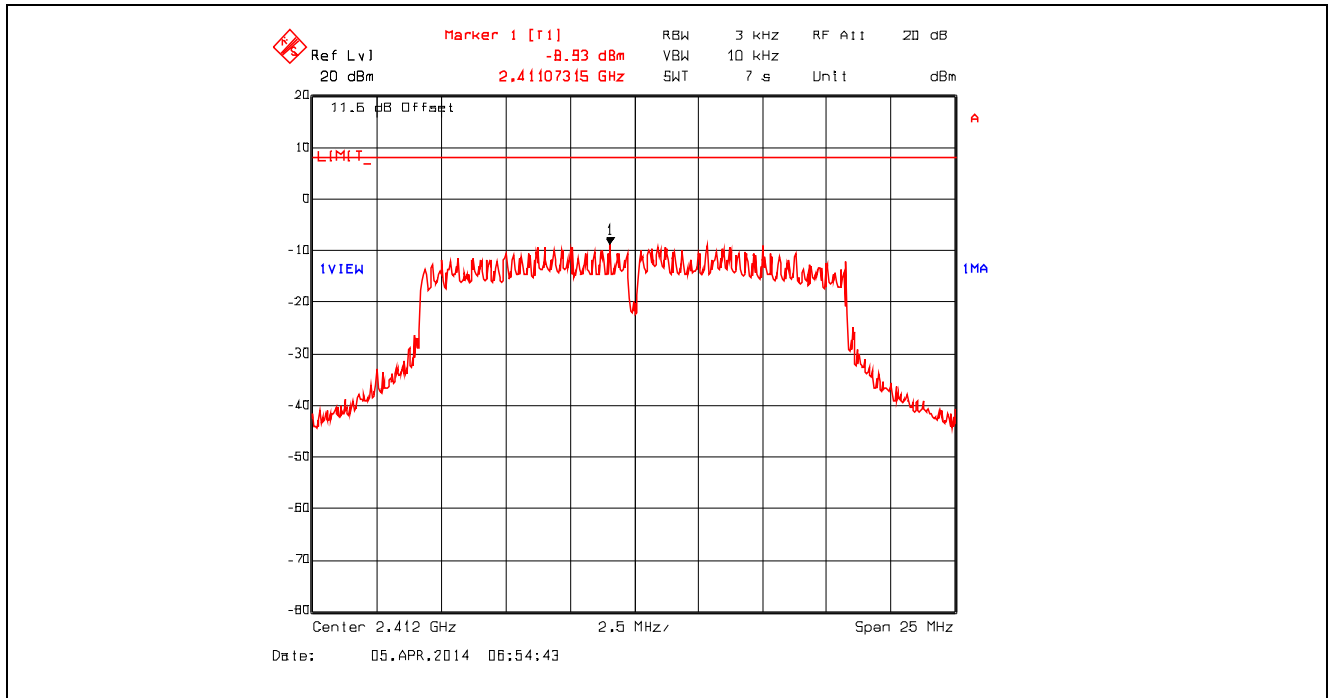

Plot 5.6.4.17. Power Spectral Density, 802.11g, 36 Mbps 16-QAM, 2437 MHz

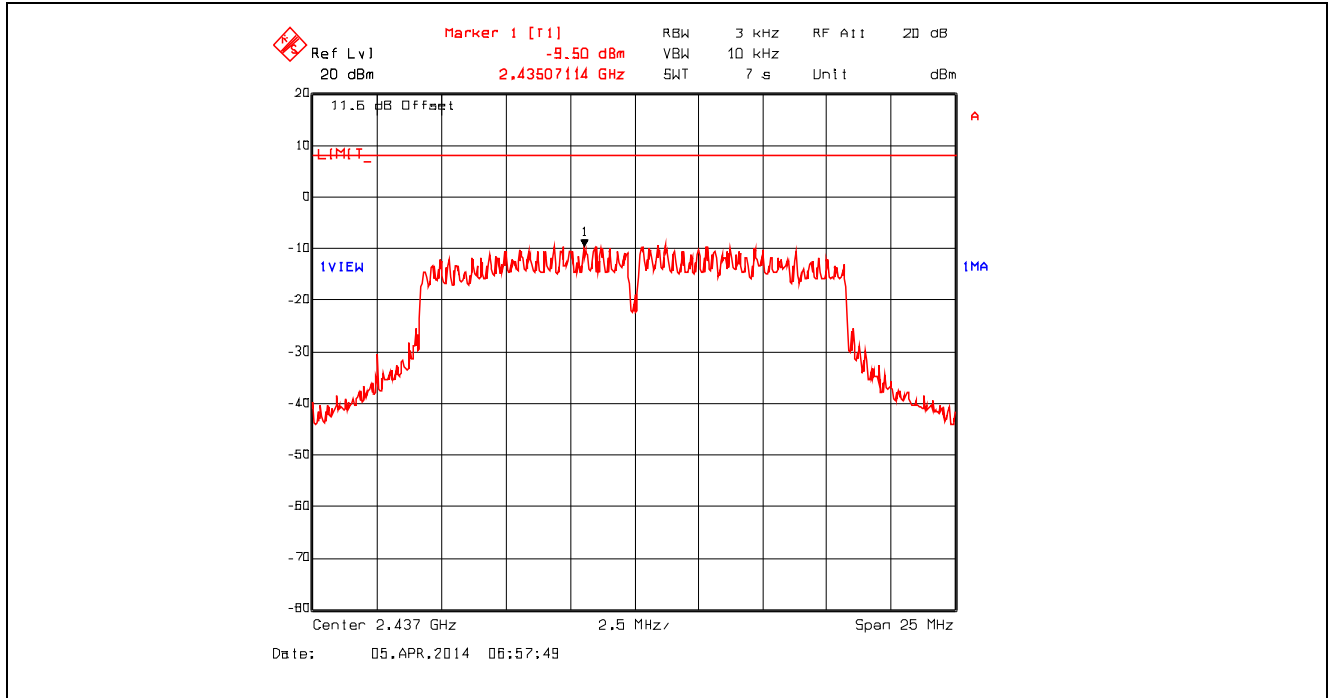

Plot 5.6.4.18. Power Spectral Density, 802.11g, 36 Mbps 16-QAM, 2462 MHz

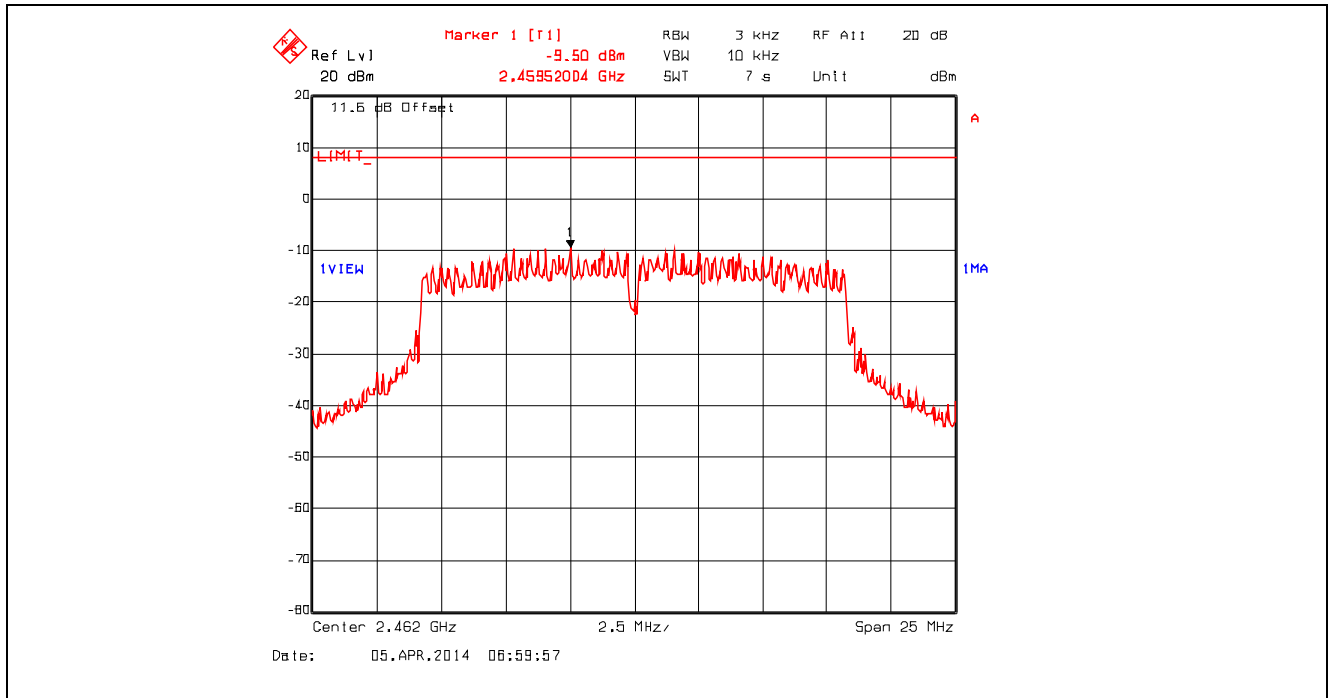

Plot 5.6.4.19. Power Spectral Density, 802.11g, 54 Mbps 64-QAM, 2412 MHz

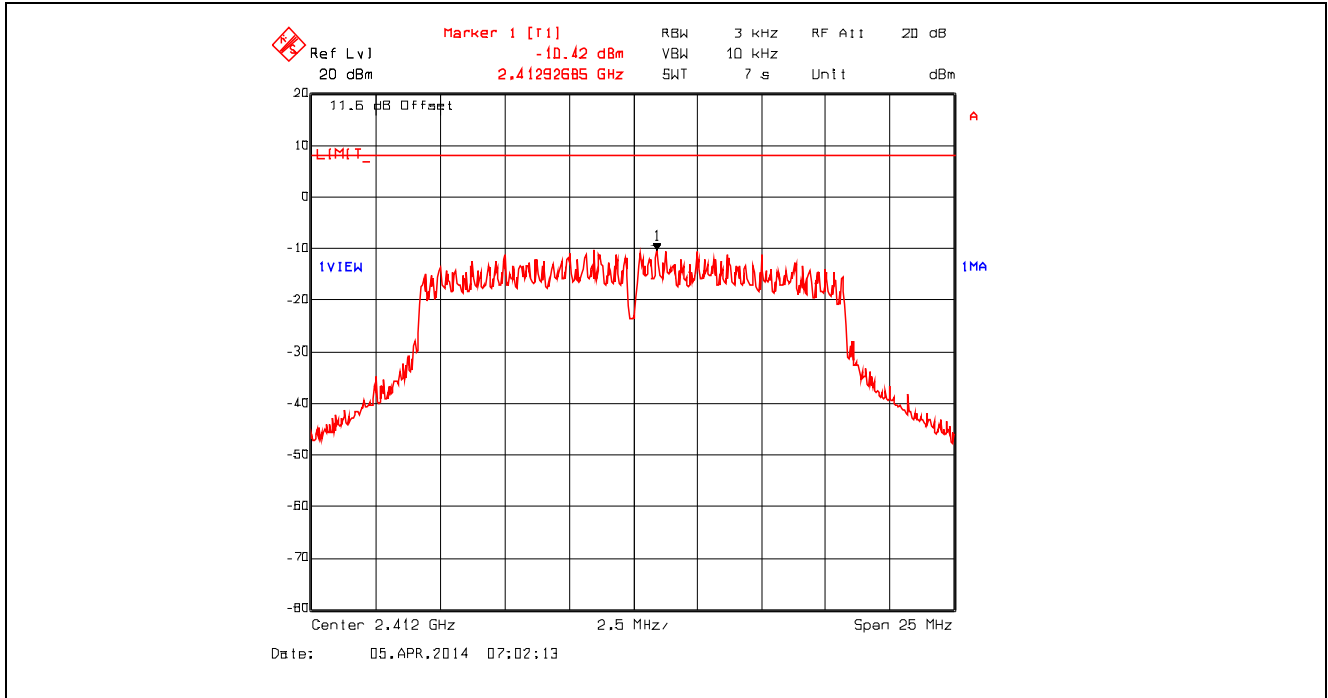

Plot 5.6.4.20. Power Spectral Density, 802.11g, 54 Mbps 64-QAM, 2437 MHz

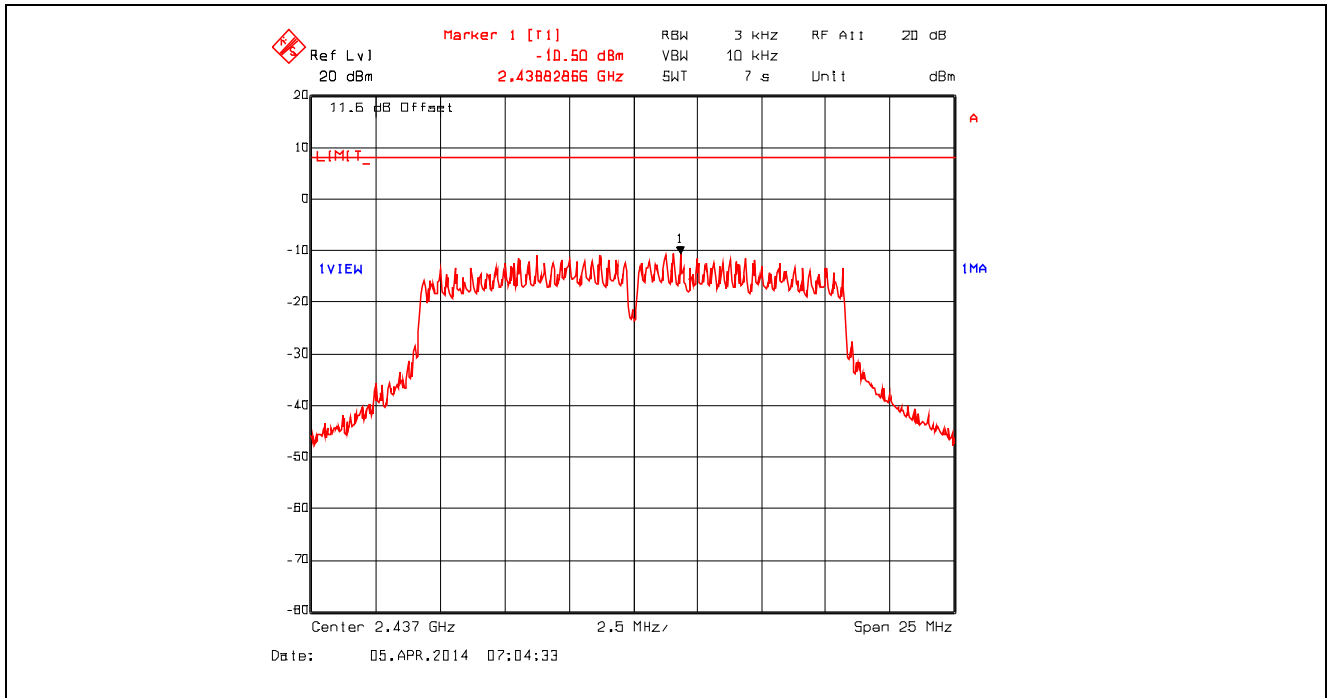

Plot 5.6.4.21. Power Spectral Density, 802.11g, 54 Mbps 64-QAM, 2462 MHz

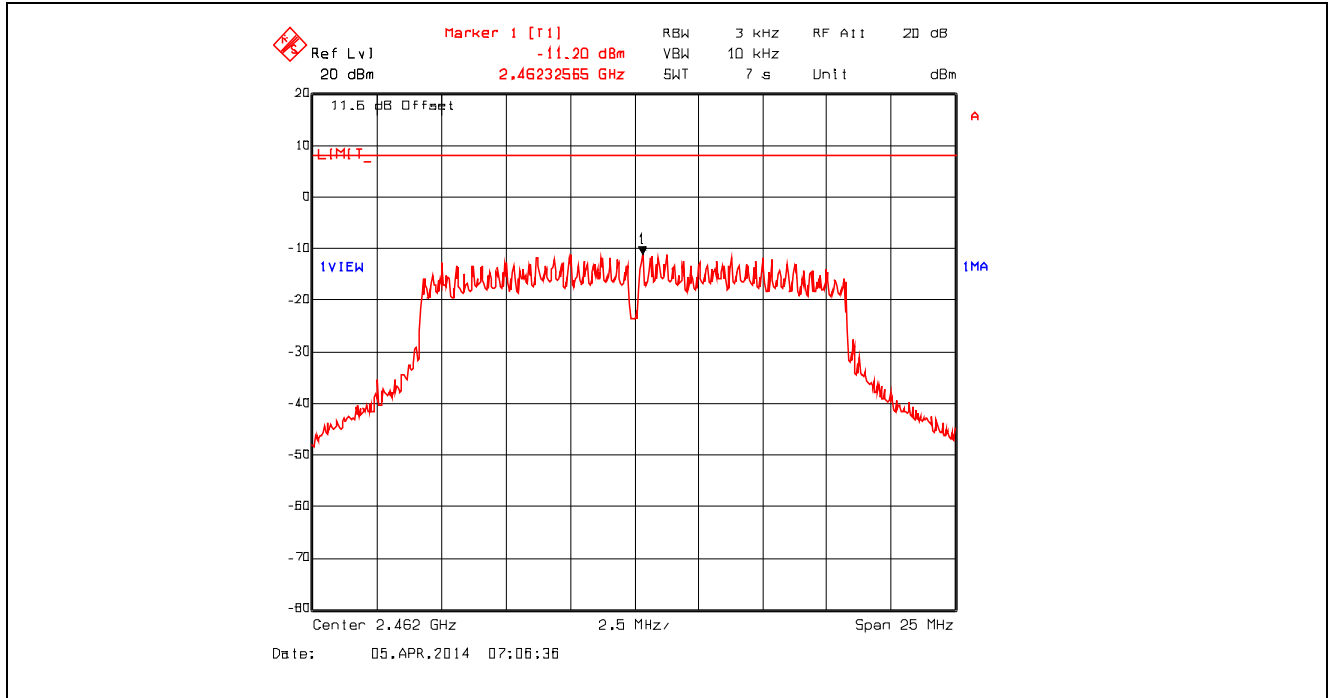

Plot 5.6.4.22. Power Spectral Density, 802.11n 800ns, 6.5 Mbps BPSK1/2, 2412 MHz

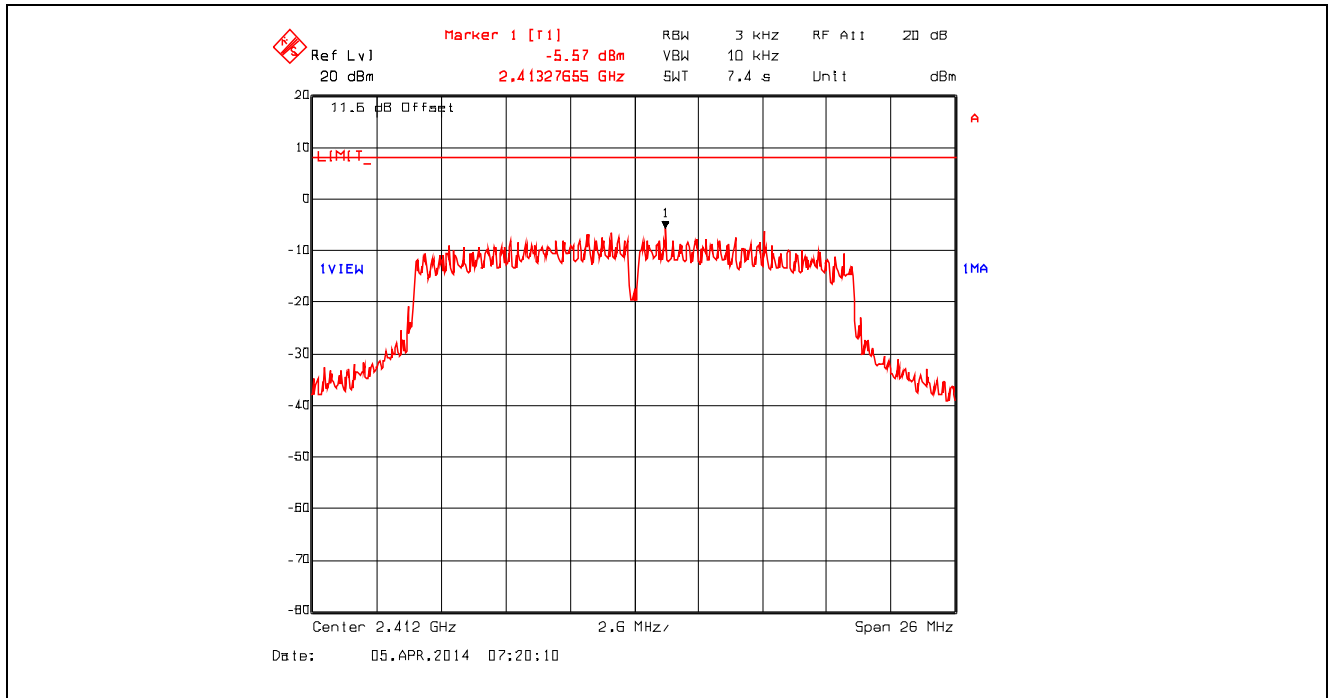

Plot 5.6.4.23. Power Spectral Density, 802.11n 800ns, 6.5 Mbps BPSK1/2, 2437 MHz

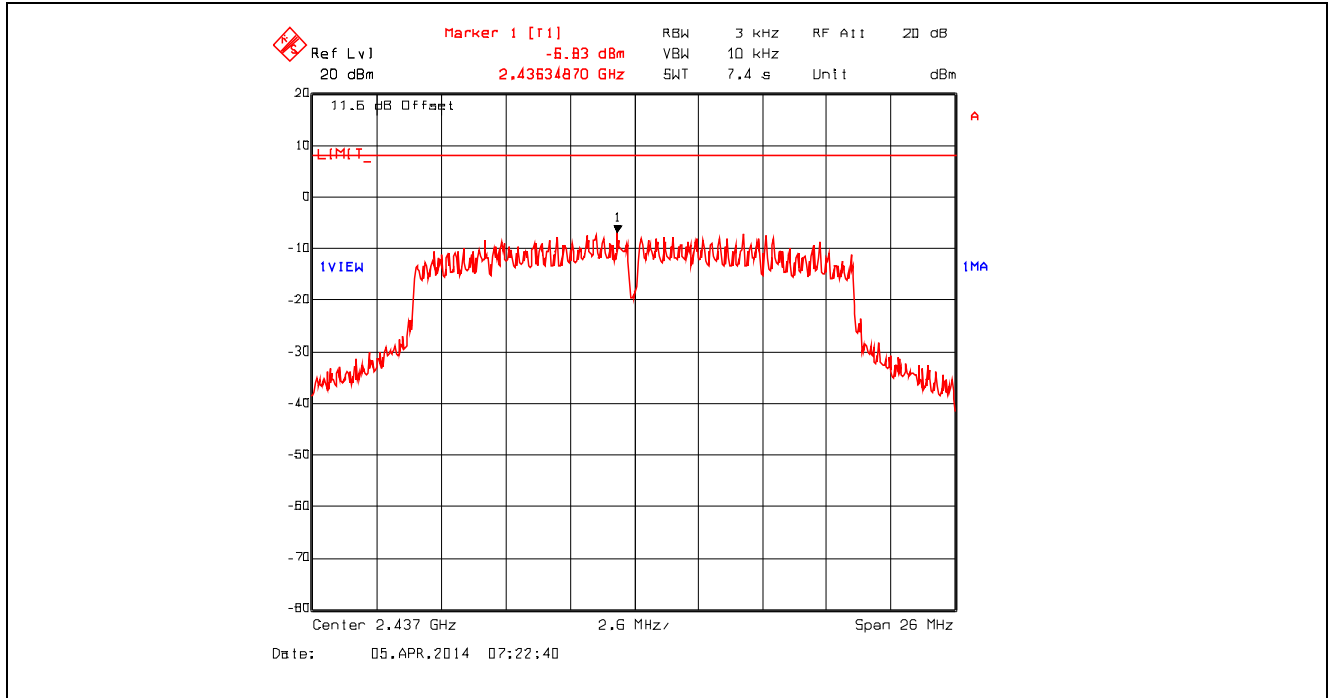

Plot 5.6.4.24. Power Spectral Density, 802.11n 800ns, 6.5 Mbps BPSK1/2, 2462 MHz

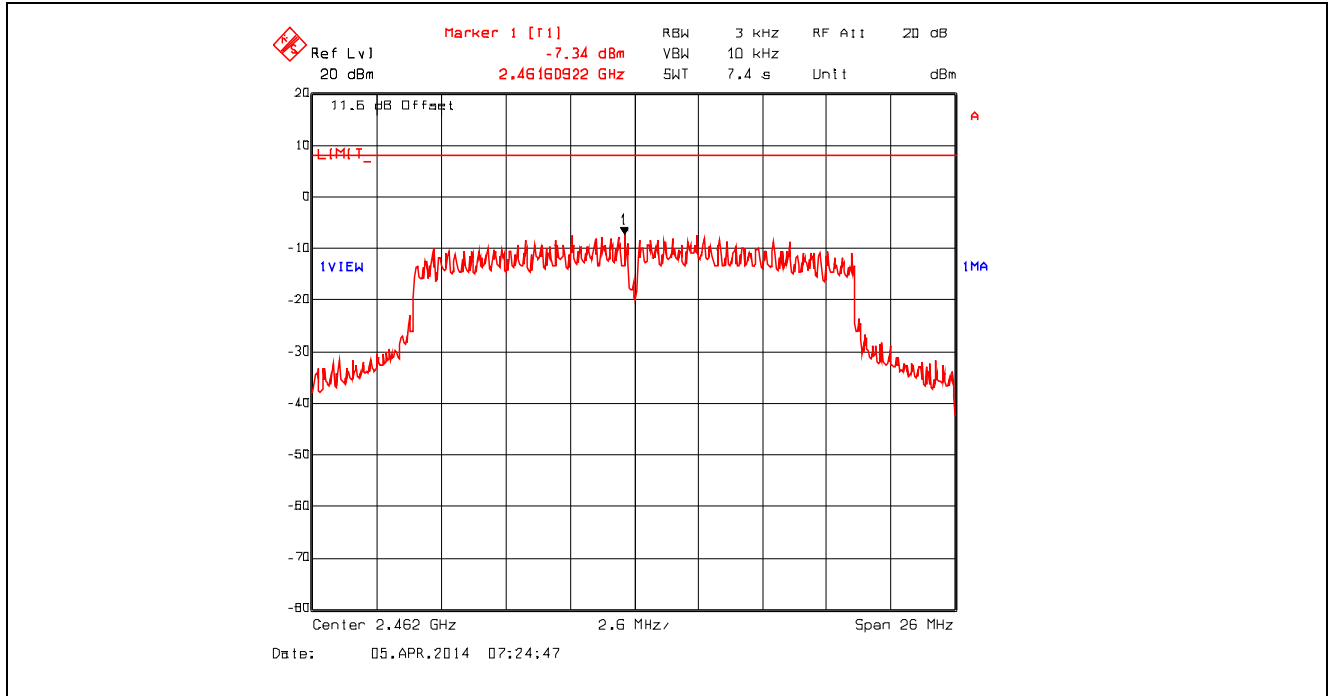

Plot 5.6.4.25. Power Spectral Density, 802.11n 800ns, 19.5 Mbps QPSK 3/4, 2412 MHz

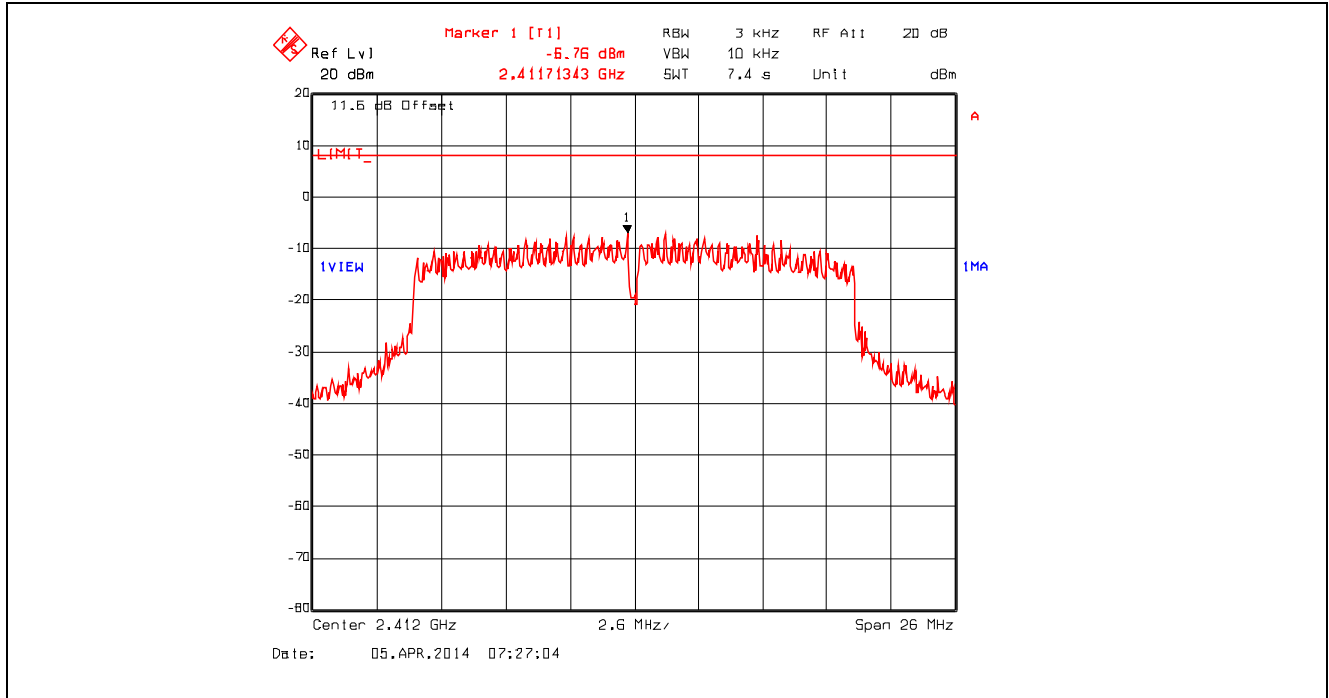

Plot 5.6.4.26. Power Spectral Density, 802.11n 800ns, 19.5 Mbps QPSK 3/4, 2437 MHz

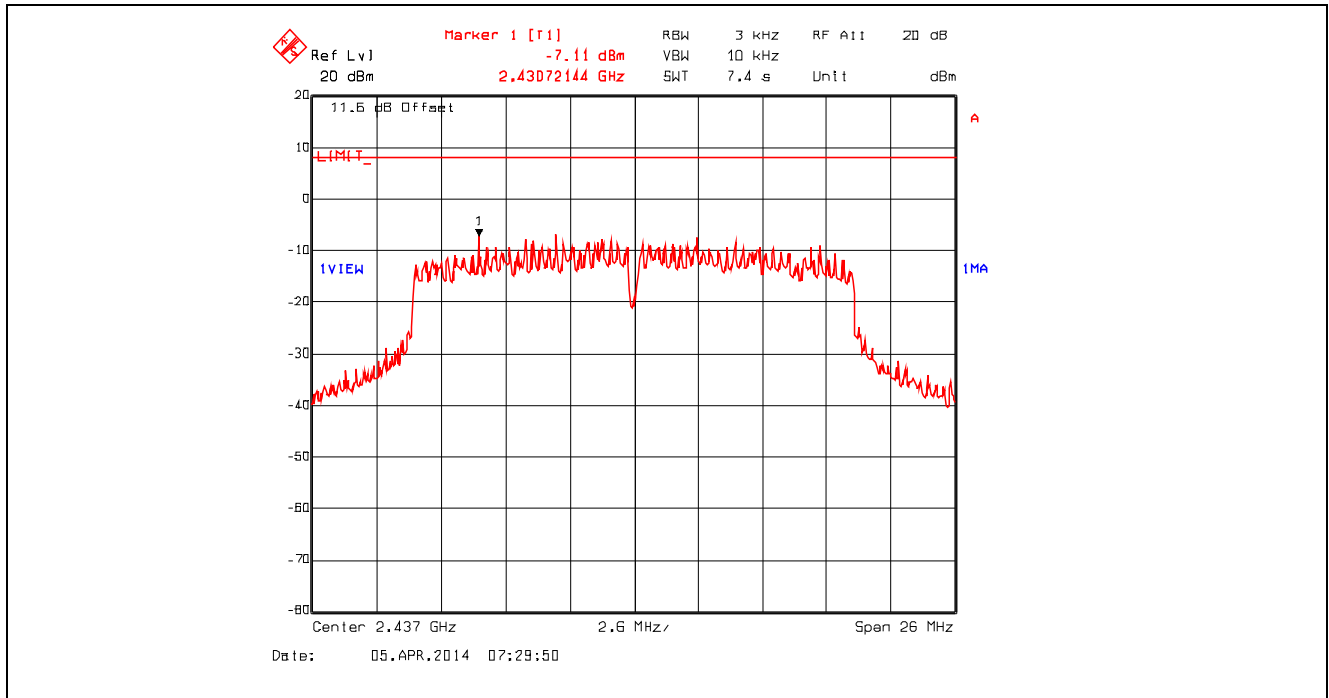

Plot 5.6.4.27. Power Spectral Density, 802.11n 800ns, 19.5 Mbps QPSK 3/4, 2462 MHz

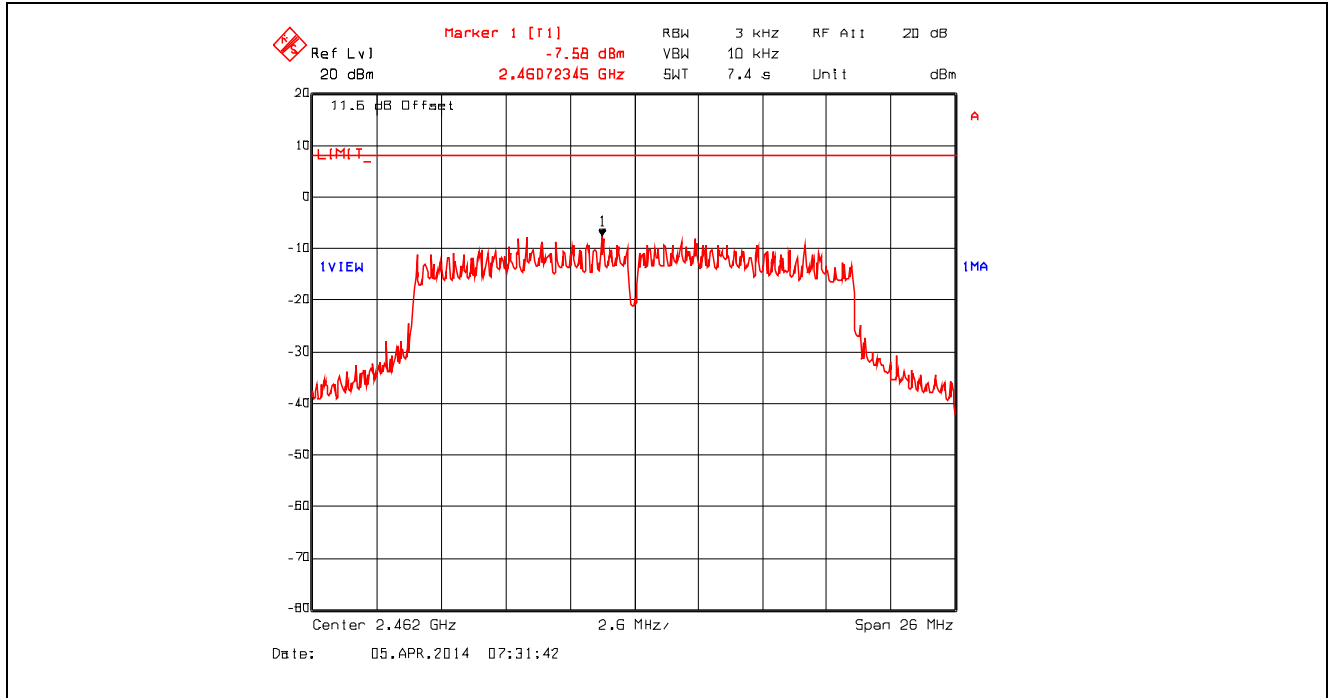

Plot 5.6.4.28. Power Spectral Density, 802.11n 800ns, 39 Mbps 16-QAM 3/4, 2412 MHz

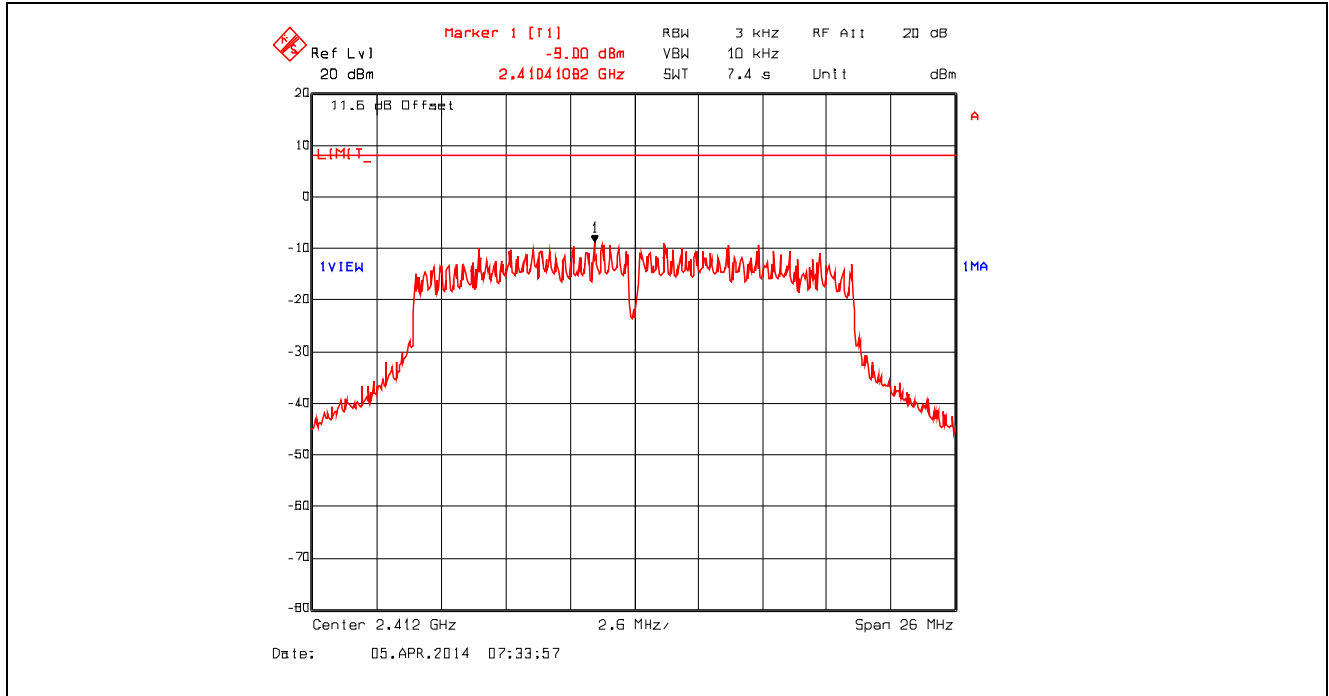

Plot 5.6.4.29. Power Spectral Density, 802.11n 800ns, 39 Mbps 16-QAM 3/4, 2437 MHz

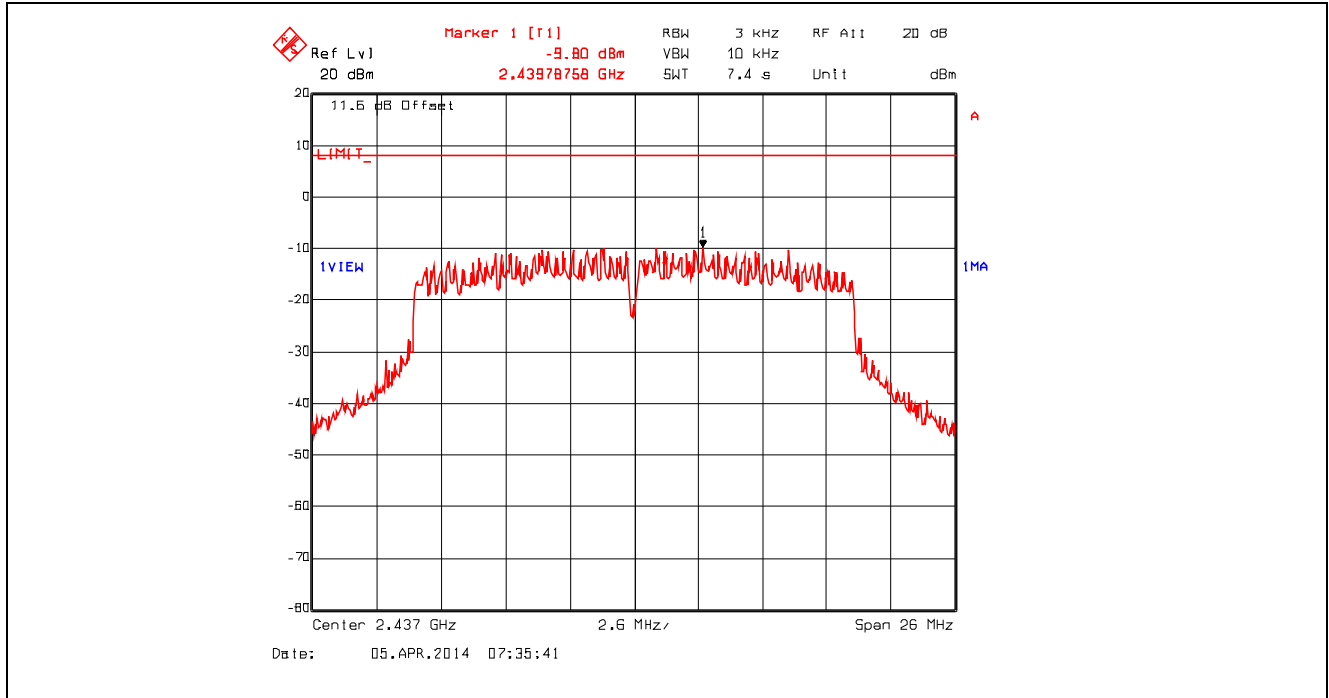

Plot 5.6.4.30. Power Spectral Density, 802.11n 800ns, 39 Mbps 16-QAM 3/4, 2462 MHz

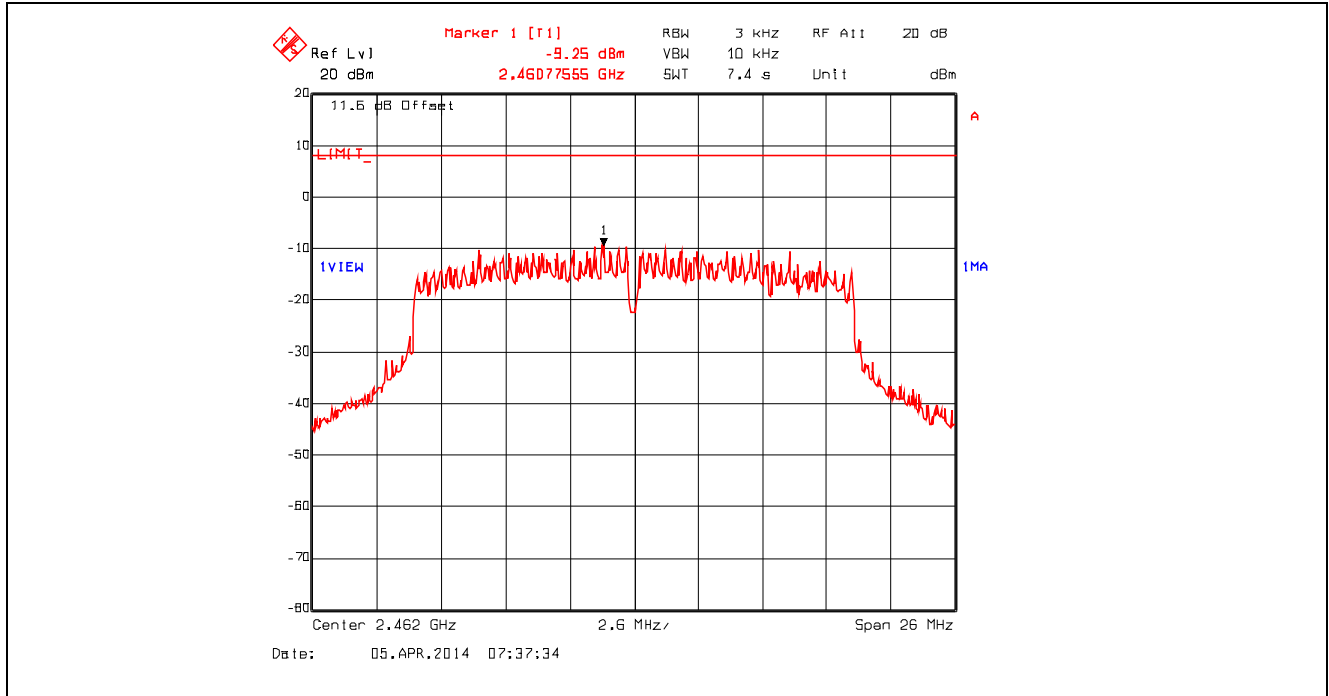

Plot 5.6.4.31. Power Spectral Density, 802.11n 800ns, 65 Mbps 64-QAM 5/6, 2412 MHz

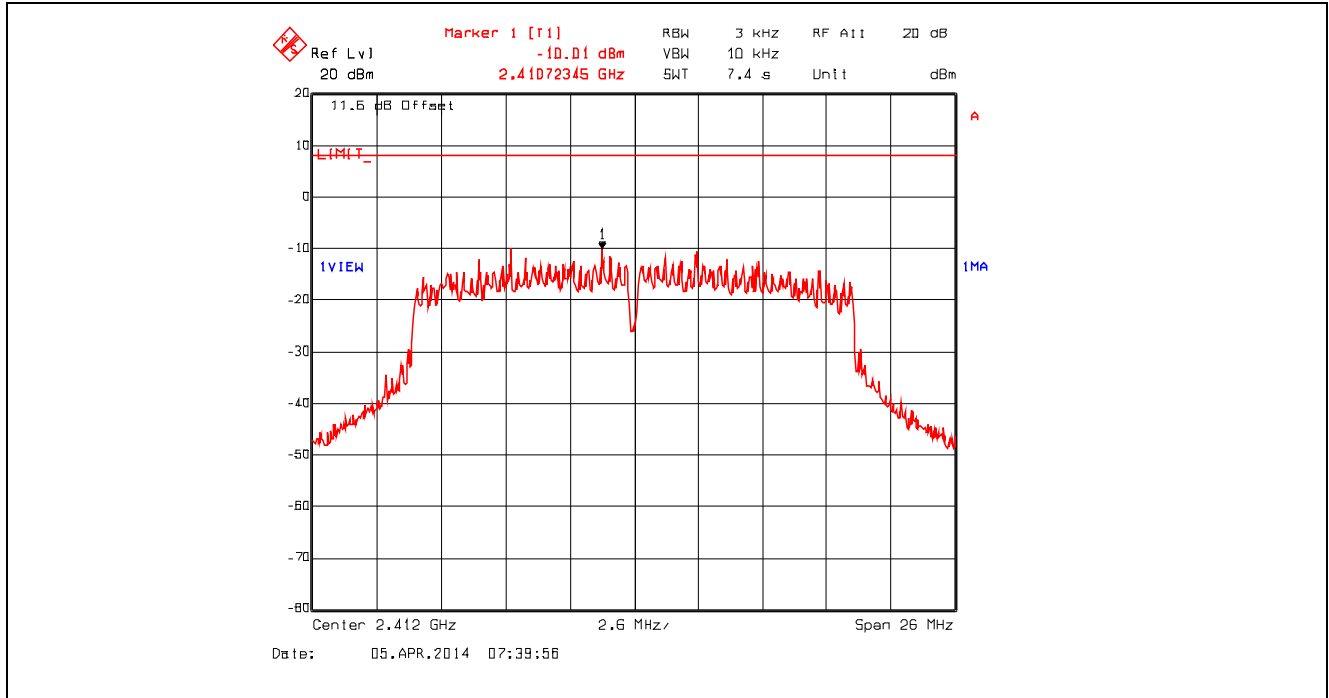

Plot 5.6.4.32. Power Spectral Density, 802.11n 800ns, 65 Mbps 64-QAM 5/6, 2437 MHz

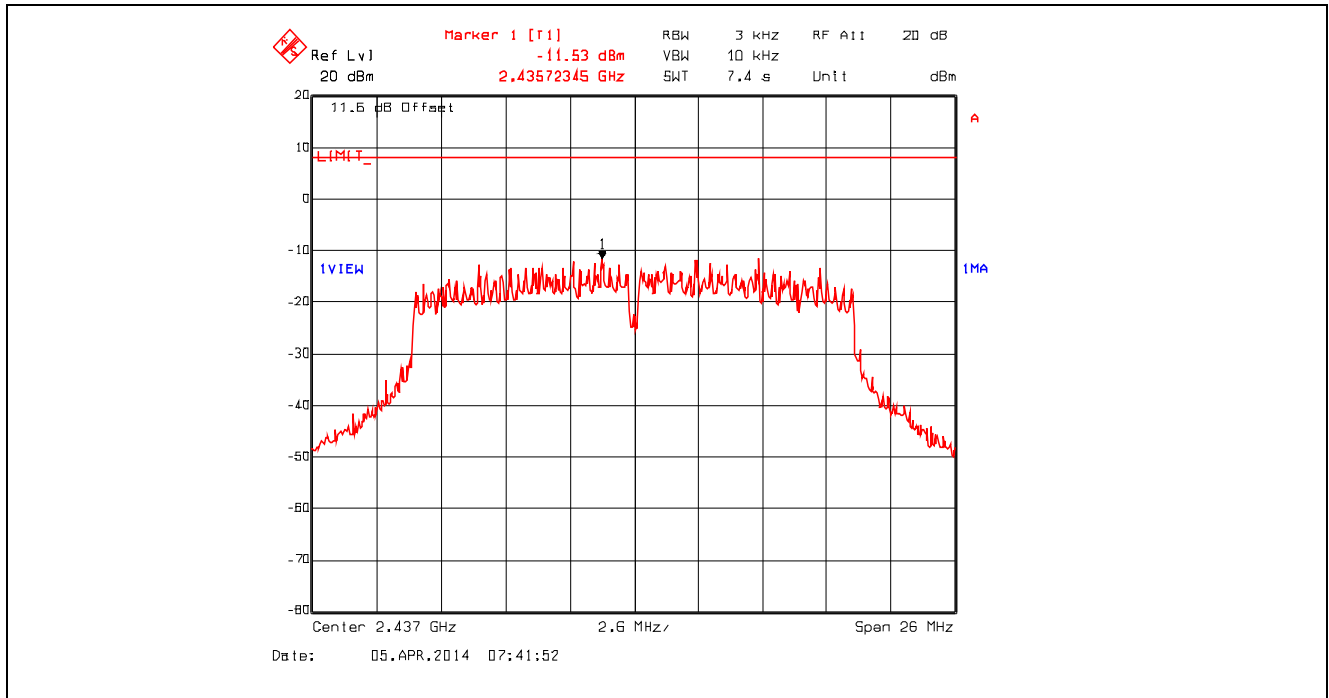

Plot 5.6.4.33. Power Spectral Density, 802.11n 800ns, 65 Mbps 64-QAM 5/6, 2462 MHz

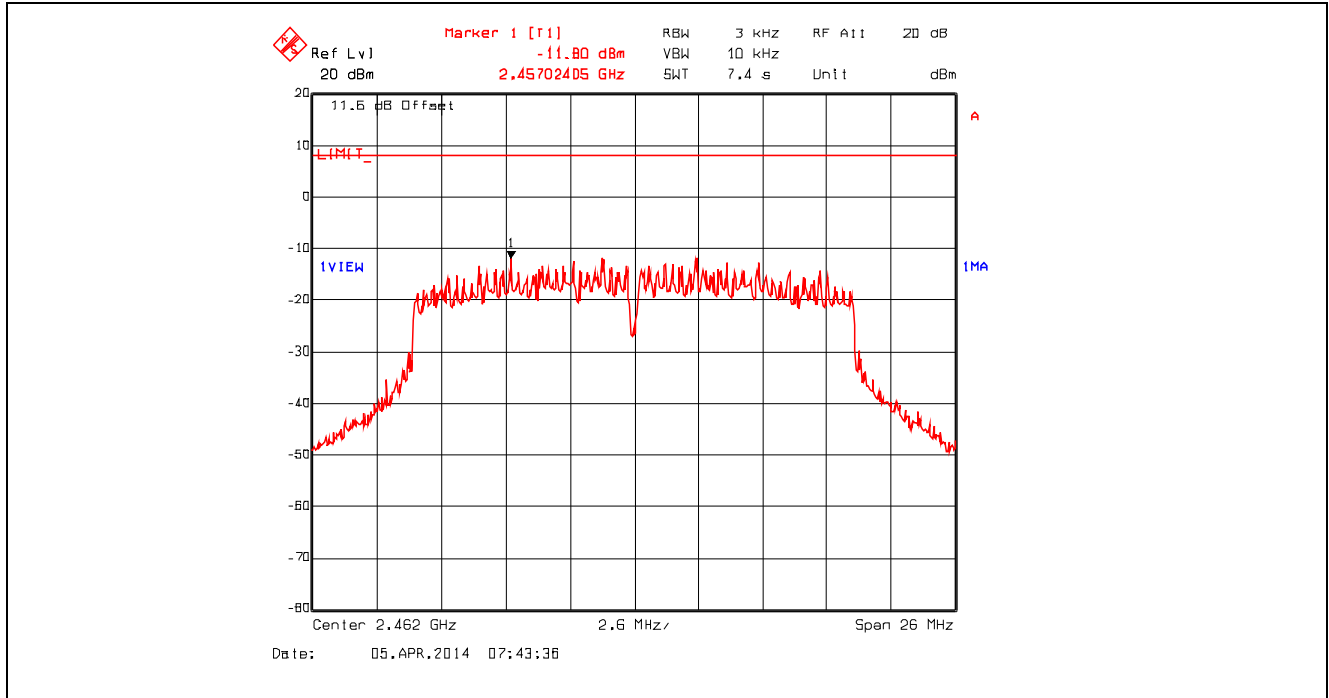

5.7. RF EXPOSURE REQUIRMENTS [§§ 15.247(e)(i), 1.1310 & 2.1091]

§ 1.1310: The criteria listed in the following table shall be used to evaluate the environmental impact of human exposure to radio-frequency (RF) radiation as specified in 1.1307(b).

Limits for Maximum Permissible Exposure (MPE)

Frequency range (MHz)	Electric field strength (V/m)	Magnetic field strength (A/m)	Power density (mW/cm ²)	Averaging time (minutes)
(A) Limits for Occupational/Controlled Exposures				
0.3-3.0	614	1.63	*(100)	6
3.0-30	1842/f	4.89/f	*(900/f ²)	6
30-300	61.4	0.163	1.0	6
300-1500			f/300	6
1500-100,000			5	6
(B) Limits for General Population/Uncontrolled Exposure				
0.3-1.34	614	1.63	*(100)	30
1.34-30	824/f	2.19/f	*(180/f ²)	30
30-300	27.5	0.073	0.2	30
300-1500			f/1500	30
1500-100,000			1.0	30

f = frequency in MHz

* = Plane-wave equivalent power density

Note 1: Occupational/controlled limits apply in situations in which persons are exposed as a consequence of their employment provided those persons are fully aware of the potential for exposure and can exercise control over their exposure. Limits for occupational/controlled exposure also apply in situations when an individual is transient through a location where occupational/controlled limits apply provided he or she is made aware of the potential for exposure.

Note 2: General population/uncontrolled exposures apply in situations in which the general public may be exposed, or in which persons that are exposed as a consequence of their employment may not be fully aware of the potential for exposure or can not exercise control over their exposure.

5.7.1. Method of Measurements

Calculation Method of RF Safety Distance:

$$S = \frac{PG}{4\pi \cdot r^2} = \frac{EIRP}{4\pi \cdot r^2}$$

Where, P: power input to the antenna in mW
 EIRP: Equivalent (effective) isotropic radiated power.
 S: power density mW/cm²
 G: numeric gain of antenna relative to isotropic radiator
 r: distance to centre of radiation in cm

$$r = \sqrt{\frac{PG}{4\pi \cdot S}} = \sqrt{\frac{EIRP}{4\pi \cdot S}}$$

5.7.2. Evaluation of RF Exposure Compliance Requirements

Operating Mode	WiFi	BT	WiFi + BT
Maximum RF Power conducted, P_{conducted}[dBm]:	23.94	9.90	24.11
Antenna Gain, G[dBi]:	2	2	2
Maximum EIRP, P_{EIRP}[dBm]:	25.94	11.90	26.11
MPE Limit for General Population/Uncontrolled Exposure, S_{controlled}[mW/cm²]:	1.0	1.0	1.0
Calculated RF Safety Distance for General Population/Uncontrolled Exposure, r_{safety_controlled}[cm]:	5.59	1.11	5.70

EXHIBIT 6. TEST EQUIPMENT LIST

Test Instruments	Manufacturer	Model No.	Serial No.	Frequency Range	Cal. Due Date
Spectrum Analyzer	Hewlett Packard	HP 8593EM	3412A00103	9 kHz–26.5 GHz	27 Mar 2015
Attenuator	Pasternack	PE7010-20	-	DC–2 GHz	02 Jan 2016
L.I.S.N	EMCO	3825/2	2209	0.10 -100 MHz	03 Sep 2015
DC Power Supply	Tenma	72-7295	490300270	1 – 40 Vdc	Cal on use.
Spectrum Analyzer	Rohde & Schwarz	FSEK30	100077	20Hz–40 GHz	08 Nov 2014
Attenuator	Pasternack	PE7024-10	4	DC–26.5 GHz	Cal on use
DC Block	Hewlett Packard	11742A	12460	0.045–26.5 GHz	Cal on use
Peak Power Analyzer	Hewlett Packard	8990A	3314A00602	0.5 - 40 GHz	30 Oct 2014
Peak Power Sensor	Hewlett Packard	84814A	3205A00175	0.5 - 40 GHz	30 Oct 2014
DC Power Supply	Tenma	72-7295	490300270	1 – 40 Vdc	Cal on use
High Pass Filter	K & L	11SH10-4000/T12000	4	Cut off 2400 MHz	Cal on use
Band Reject Filter	Micro-Tronics	BRM50701	105	Cut off 2.4-2.483 GHz	Cal on use
Spectrum Analyzer	Rohde & Schwarz	FSP	100646	9 kHz – 7 GHz	25 Sep 2014
RF Amplifier	Hewlett Packard	84498	3008A00769	1 – 26.5 GHz	25 Jun 2014
RF Amplifier	Hewlett Packard	8447F	2805A03287	0.1 – 1300 MHz	15 Mar 2015
Biconi-Log Antenna	EMCO	3142C	34792	26 – 3000 MHz	26 Jun 2014
Horn Antenna	EMCO	3155	6570	1 – 18 GHz	07 Jun 2014
Horn Antenna	EMCO	3160-09	118385	18 – 26.5 GHz	30 July 2014
Note 1: Internal Verification/Calibration check on use.					

EXHIBIT 7. MEASUREMENT UNCERTAINTY

The measurement uncertainties stated were calculated in accordance with the requirements of CISPR 16-4-2 @ IEC:2003 and JCGM 100:2008 (GUM 1995) – Guide to the Expression of Uncertainty in Measurement.

7.1. LINE CONDUCTED EMISSION MEASUREMENT UNCERTAINTY

	Line Conducted Emission Measurement Uncertainty (9 kHz – 30 MHz):	Measured	Limit
u_c	Combined standard uncertainty: $u_c(y) = \sqrt{\sum_{i=1}^m u_i^2(y)}$	± 1.44	± 1.8
U	Expanded uncertainty U: $U = 2u_c(y)$	± 2.89	± 3.6

7.2. RADIATED EMISSION MEASUREMENT UNCERTAINTY

	Radiated Emission Measurement Uncertainty @ 3m, Horizontal (30-1000 MHz):	Measured (dB)	Limit (dB)
u_c	Combined standard uncertainty: $u_c(y) = \sqrt{\sum_{i=1}^m u_i^2(y)}$	± 2.39	± 2.6
U	Expanded uncertainty U: $U = 2u_c(y)$	± 4.79	± 5.2

	Radiated Emission Measurement Uncertainty @ 3m, Vertical (30-1000 MHz):	Measured (dB)	Limit (dB)
u_c	Combined standard uncertainty: $u_c(y) = \sqrt{\sum_{i=1}^m u_i^2(y)}$	± 2.39	± 2.6
U	Expanded uncertainty U: $U = 2u_c(y)$	± 4.78	± 5.2

	Radiated Emission Measurement Uncertainty @ 3 m, Horizontal & Vertical (1 – 18 GHz):	Measured (dB)	Limit (dB)
u_c	Combined standard uncertainty: $u_c(y) = \sqrt{\sum_{i=1}^m u_i^2(y)}$	± 1.87	Under consideration
U	Expanded uncertainty U: $U = 2u_c(y)$	± 3.75	Under consideration