

# ENGINEERING TEST REPORT

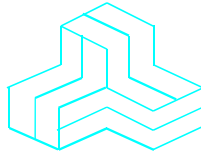

**IXM SENSE PROXL**  
**Model: IXM122**  
**FCC ID: S38-TSPROX**

Applicant:

**Invixium Access Inc.**  
#5 – 205 Riviera Drive  
Markham, Ontario  
Canada L3R 5J8

**In Accordance With  
Federal Communications Commission (FCC)  
Part 15, Subpart C, Section 15.209**

**UltraTech's File No.: 16IN VX028\_FCC15C209**

This Test report is Issued under the Authority of  
Tri M. Luu  
Vice President of Engineering  
UltraTech Group of Labs

Date: February 10, 2016

Report Prepared by: Dan Huynh

Tested by: Hung Trinh

Issued Date: February 10, 2016

Test Date(s): September 15, 2014

- *The results in this Test Report apply only to the sample(s) tested, and the sample tested is randomly selected.*
- *This report must not be used by the client to claim product endorsement by NVLAP or any agency of the US Government.*

## UltraTech

3000 Bristol Circle, Oakville, Ontario, Canada, L6H 6G4  
Tel.: (905) 829-1570 Fax.: (905) 829-8050  
Website: [www.ultratech-labs.com](http://www.ultratech-labs.com), Email: [vic@ultratech-labs.com](mailto:vic@ultratech-labs.com), Email: [tri@ultratech-labs.com](mailto:tri@ultratech-labs.com)



91038



1309



46390-2049



NVLAP LAB  
CODE 200093-0



AT-1945



SL2-IN-E-  
1119R



Korea  
KCC-RRR

CA2049



TL363\_B



TPTDP  
DA1300

**TABLE OF CONTENTS**

**EXHIBIT 1. INTRODUCTION..... 1**

- 1.1. SCOPE ..... 1
- 1.2. RELATED SUBMITTAL(S)/GRANT(S) ..... 1
- 1.3. NORMATIVE REFERENCES ..... 1

**EXHIBIT 2. PERFORMANCE ASSESSMENT..... 2**

- 2.1. CLIENT INFORMATION ..... 2
- 2.2. EQUIPMENT UNDER TEST (EUT) INFORMATION ..... 2
- 2.3. EUT'S TECHNICAL SPECIFICATIONS..... 3
- 2.4. LIST OF EUT'S PORTS..... 3
- 2.5. ANCILLARY EQUIPMENT ..... 4
- 2.6. TEST SETUP BLOCK DIAGRAM ..... 4

**EXHIBIT 3. EUT OPERATING CONDITIONS AND CONFIGURATIONS DURING TESTS..... 5**

- 3.1. CLIMATE TEST CONDITIONS..... 5
- 3.2. OPERATIONAL TEST CONDITIONS & ARRANGEMENT FOR TESTS..... 5

**EXHIBIT 4. SUMMARY OF TEST RESULTS ..... 6**

- 4.1. LOCATION OF TESTS ..... 6
- 4.2. APPLICABILITY & SUMMARY OF EMC EMISSION TEST RESULTS ..... 6
- 4.3. MODIFICATIONS INCORPORATED IN THE EUT FOR COMPLIANCE PURPOSES..... 6

**EXHIBIT 5. TEST DATA ..... 7**

- 5.1. TRANSMITTER RADIATED EMISSIONS [47 CFR §§ 15.209 & 15.205] ..... 7
- 5.2. 20 dB BANDWIDTH [47 CFR 15.209 (a)] ..... 10

**EXHIBIT 6. TEST EQUIPMENT LIST ..... 11**

**EXHIBIT 7. MEASUREMENT UNCERTAINTY..... 12**

- 7.1. RADIATED EMISSION MEASUREMENT UNCERTAINTY ..... 12

## EXHIBIT 1. INTRODUCTION

### 1.1. SCOPE

<b>Reference:</b>	FCC Part 15, Subpart C
<b>Title:</b>	Code of Federal Regulations (CFR), Title 47 – Telecommunication, Part 15 – Radio Frequency Devices
<b>Purpose of Test:</b>	Equipment Certification for FCC Part 15C.
<b>Test Procedures:</b>	ANSI C63.4 and ANSI C63.10
<b>Environmental Classification:</b>	Commercial, industrial or business environment

### 1.2. RELATED SUBMITTAL(S)/GRANT(S)

None.

### 1.3. NORMATIVE REFERENCES

Publication	Year	Title
FCC 47 CFR 15	2015	Code of Federal Regulations (CFR), Title 47 – Telecommunication, Part 15 – Radio Frequency Devices
ANSI C63.4	2009	American National Standard for Methods of Measurement of Radio-Noise Emissions from Low-Voltage Electrical and Electronic Equipment in the Range of 9 KHz to 40 GHz
ANSI C63.10	2013	American National Standard of Procedures for Compliance Testing of Unlicensed Wireless Devices
CISPR 22 EN 55022	2008-09, Edition 6.0 2006	Information Technology Equipment - Radio Disturbance Characteristics - Limits and Methods of Measurement

## EXHIBIT 2. PERFORMANCE ASSESSMENT

### 2.1. CLIENT INFORMATION

Applicant	
<b>Name:</b>	Invixium Access Inc.
<b>Address:</b>	#5 – 205 Riviera Drive Markham, Ontario Canada L3R 5J8
<b>Contact Person:</b>	Shiraz Kapadia Phone #: 647-282-1745 (M) Fax #: N/A Email Address: skapadia@invixium.com

Manufacturer	
<b>Name:</b>	Mara Technologies Inc.
<b>Address:</b>	5680 14th Avenue Markham, Ontario Canada L3S 3K8
<b>Contact Person:</b>	Matthew Ruscica Phone #: 1-905-201-1787 Fax #: 1-905-201-9114 Email Address: matthew@maratech.ca

### 2.2. EQUIPMENT UNDER TEST (EUT) INFORMATION

The following information (with the exception of the Date of Receipt) has been supplied by the applicant.

<b>Brand Name:</b>	Invixium Access Inc.
<b>Product Name:</b>	IXM SENSE PROXL
<b>Model Name or Number:</b>	IXM122
<b>Serial Number:</b>	Test sample
<b>Type of Equipment:</b>	Part 15 Low Power Transmitter Below 1705 kHz
<b>Input Power Supply Type:</b>	12-24V DC external power supply
<b>Primary User Functions of EUT:</b>	Identifies person, either by fingerprint matching, or by proximity card, or both. Sends result of identification to Access Control Panel, or to Time and Attendance software application., or to Smart Home controller

### 2.3. EUT'S TECHNICAL SPECIFICATIONS

<b>Transmitter</b>	
<b>Intended Operating Environment:</b>	Commercial, light industry & heavy industry
<b>Power Supply Requirement:</b>	5V DC
<b>RF Output Power Rating:</b>	53.85 dBμV/m peak at 3m distance
<b>Operating Frequency Range:</b>	125 kHz
<b>20 dB Bandwidth:</b>	1.21 kHz
<b>Modulation Type:</b>	Unmodulated carrier
<b>Oscillator Frequencies:</b>	125 kHz
<b>Antenna Connector Type:</b>	720 uH coil, 125 kHz, Air Tuned Antenna

### 2.4. LIST OF EUT'S PORTS

<b>Port Number</b>	<b>EUT's Port Description</b>	<b>Number of Identical Ports</b>	<b>Connector Type</b>	<b>Cable Type (Shielded/Non-shielded)</b>
1	Wiegand Output (to Access Control Panel), 2 lines	1	Header	Non-shielded
2	Wiegand Input (from external RFID), 2 lines	1	Header	30cm, non-shielded
3	Ethernet !00 BASET X	1	RJ-45 on cable	Non-shielded
4	RS-485 (slave), 2 lines	1	Header	Non-shielded
5	RS-232, 2 lines (Service Port)*	1	DB-9, socket on cable	Non-shielded
6	Form C Relay, 3 lines	1	Header	Non-shielded
7	GPO, 4 lines	1	Header	Non-shielded
8	GPI, 8 lines	1	Header	Non-shielded
9	GND, 5 lines	1	Header	Non-shielded
10	USB OTG (Service Port)*	1	USB-Micro-AB	Shielded (service port)
11	Power Input (12-24V)	1	Header	Non-shielded
12	EGND	1	Header	Non-shielded

\* Used for service by administrator only.

**2.5. ANCILLARY EQUIPMENT**

The EUT was tested while connected to the following representative configuration of ancillary equipment necessary to exercise the ports during tests:

<b>Ancillary Equipment # 1</b>	
Description:	Proximity Card
Brand Name:	HID
Model Name or Number:	Prox Card II
Serial Number:	N/A
Cable Length & Type:	N/A
Connected to EUT's Port:	N/A

**2.6. TEST SETUP BLOCK DIAGRAM**

**2.6.1. Radiated Emission Test Setup**

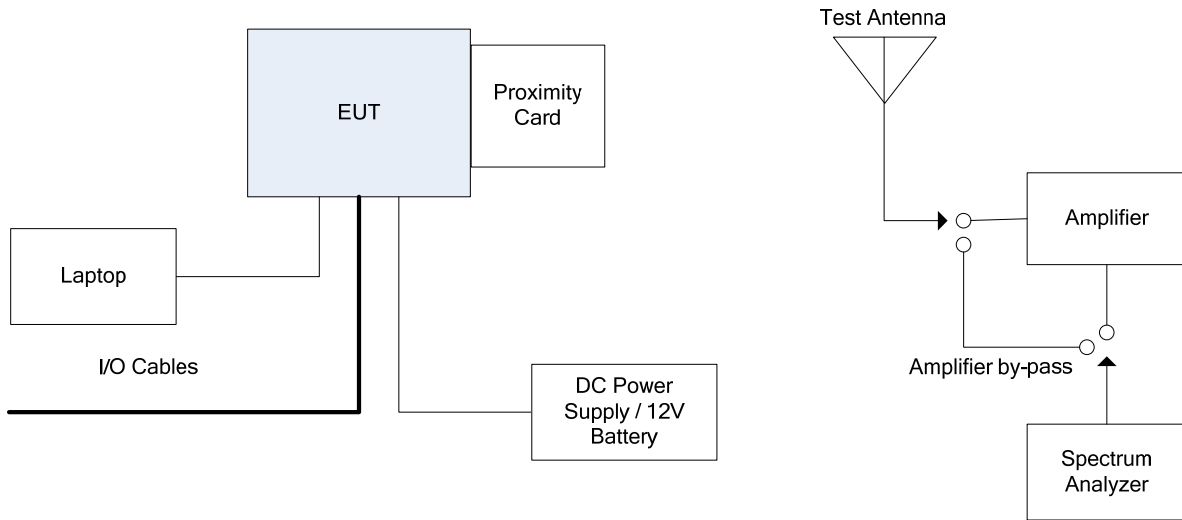

### EXHIBIT 3. EUT OPERATING CONDITIONS AND CONFIGURATIONS DURING TESTS

#### 3.1. CLIMATE TEST CONDITIONS

The climate conditions of the test environment are as follows:

Temperature:	21°C
Humidity:	51%
Pressure:	102 kPa
Power input source:	12-24 VDC

#### 3.2. OPERATIONAL TEST CONDITIONS & ARRANGEMENT FOR TESTS

<b>Operating Modes:</b>	The EUT was configured for continuous transmission for the duration of testing.
<b>Special Test Software:</b>	N/A
<b>Special Hardware Used:</b>	N/A
<b>Transmitter Test Antenna:</b>	The EUT was tested with the antenna fitted in a manner typical of normal intended use as integral antenna equipment.

<b>Transmitter Test Signals</b>	
<b>Frequency Band(s):</b>	125 kHz
<b>Test Frequency(ies):</b>	125 kHz
<b>RF Power Output:</b>	53.85 dBμV/m peak at 3m distance
<b>Normal Test Modulation:</b>	Unmodulated carrier
<b>Modulating Signal Source:</b>	Internal

## EXHIBIT 4. SUMMARY OF TEST RESULTS

### 4.1. LOCATION OF TESTS

All of the measurements described in this report were performed at Ultratech Group of Labs located in the city of Oakville, Province of Ontario, Canada.

- AC Power Line Conducted Emissions were performed in UltraTech's shielded room, 24'(L) by 16'(W) by 8'(H).
- Radiated Emissions were performed at the Ultratech's 3-10 TDK Semi-Anechoic Chamber situated in the Town of Oakville, province of Ontario. This test site been calibrated in accordance with ANSI C63.4, and found to be in compliance with the requirements of Sec. 2.948 of the FCC Rules. The descriptions and site measurement data of the Oakville 3-10 TDK Semi-Anechoic Chamber has been filed with FCC office (FCC File No.: 91038) and Industry Canada office (Industry Canada File No.: 2049A-3). Expiry Date: 2017-04-02.

### 4.2. APPLICABILITY & SUMMARY OF EMC EMISSION TEST RESULTS

FCC Section(s)	Test Requirements	Compliance (Yes/No)
15.203	Antenna Requirement	Yes*
15.207(a)	Power Line Conducted Emissions	Yes**
15.209(a)	20 dB Bandwidth	Yes
15.209	Transmitter Radiated Emissions - Fundamental, Harmonic and Spurious Emissions	Yes

\* The EUT complies with the requirement; it employs integral antenna.

\*\* Refer to attestation letter from the Applicant.

### 4.3. MODIFICATIONS INCORPORATED IN THE EUT FOR COMPLIANCE PURPOSES

The device shall be installed with Steward Ferrite on Ethernet and DC power line cables in order to meet the limit of radiated emissions. Part # 28A2432 will be used for Ethernet wires with 2 ½ turns. Part # 28A3039 will be used for DC power line wires with 2 ½ turns.

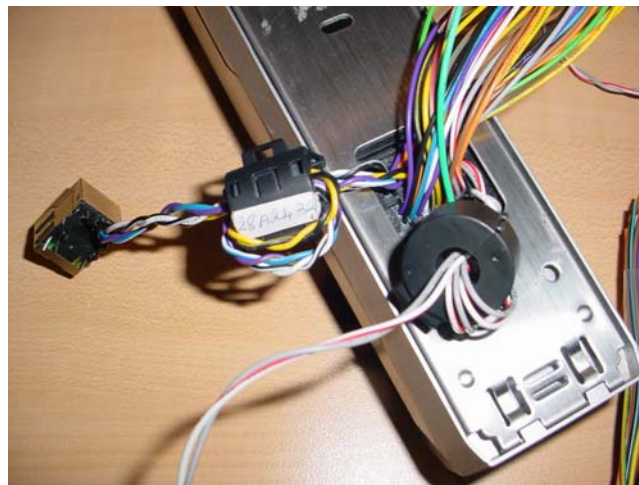



**EXHIBIT 5. TEST DATA**

**5.1. TRANSMITTER RADIATED EMISSIONS [47 CFR §§ 15.209 & 15.205]**

**5.1.1. Limit(s)**

§ 15.209 Radiated emission limits; general requirements.

(a) Except as provided elsewhere in this subpart, the emissions from an intentional radiator shall not exceed the field strength levels specified in the following table:

Frequency (MHz)	Field strength (microvolts/meter)	Measurement distance (meters)
0.009-0.490	2400/F(kHz)	300
0.490-1.705	24000/F(kHz)	30
1.705-30.0	30	30
30-88	100 **	3
88-216	150 **	3
216-960	200 **	3
Above 960	500	3

\*\* Except as provided in paragraph (g), fundamental emissions from intentional radiators operating under this section shall not be located in the frequency bands 54-72 MHz, 76-88 MHz, 174-216 MHz or 470-806 MHz. However, operation within these frequency bands is permitted under other sections of this part, e.g., §§ 15.231 and 15.241.

(b) In the emission table above, the tighter limit applies at the band edges.

(c) The level of any unwanted emissions from an intentional radiator operating under these general provisions shall not exceed the level of the fundamental emission. For intentional radiators which operate under the provisions of other sections within this part and which are required to reduce their unwanted emissions to the limits specified in this table, the limits in this table are based on the frequency of the unwanted emission and not the fundamental frequency. However, the level of any unwanted emissions shall not exceed the level of the fundamental frequency.

(d) The emission limits shown in the above table are based on measurements employing a CISPR quasi-peak detector except for the frequency bands 9-90 kHz, 110-490 kHz and above 1000 MHz. Radiated emission limits in these three bands are based on measurements employing an average detector.

(e) The provisions in §§ 15.31, 15.33, and 15.35 for measuring emissions at distances other than the distances specified in the above table, determining the frequency range over which radiated emissions are to be measured, and limiting peak emissions apply to all devices operated under this part.

(f) In accordance with § 15.33(a), in some cases the emissions from an intentional radiator must be measured to beyond the tenth harmonic of the highest fundamental frequency designed to be emitted by the intentional radiator because of the incorporation of a digital device. If measurements above the tenth harmonic are so required, the radiated emissions above the tenth harmonic shall comply with the general radiated emission limits applicable to the incorporated digital device, as shown in § 15.109 and as based on the frequency of the emission being measured, or, except for emissions contained in the restricted frequency bands shown in § 15.205, the limit

on spurious emissions specified for the intentional radiator, whichever is the higher limit. Emissions which must be measured above the tenth harmonic of the highest fundamental frequency designed to be emitted by the intentional radiator and which fall within the restricted bands shall comply with the general radiated emission limits in § 15.109 that are applicable to the incorporated digital device.

(g) Perimeter protection systems may operate in the 54-72 MHz and 76-88 MHz bands under the provisions of this section. The use of such perimeter protection systems is limited to industrial, business and commercial applications.

**5.1.2. Method of Measurements**

ANSI C63.4 for measurement methods.

**5.1.3. Test Data**

**Remarks:**

- The measuring receiver shall be tuned over the frequency range 10 kHz to 1 GHz.
- All spurious emissions that are in excess of 20 dB below the specified limit shall be recorded.
- EUT was initially tested at 3m and the value measured at 3m shall be extrapolated as applicable to compare with limit and measurement distance specified in section 15.209(a).
- Extrapolation factor of 40dB/decade shall be used for frequencies below 30 MHz.

**5.1.3.1. Fundamental Emissions**

<p><b>Remarks:</b></p> <ul style="list-style-type: none"> <li>• Field strength limit of the fundamental 125 kHz at 300m distance is <math>20 \cdot \log(2400/125) = 25.7 \text{ dB}\mu\text{V/m}</math></li> <li>• For frequency band 0.009- 0.490 MHz, the measured E-Field at 3m (column 2) will be extrapolated to 300m E-Field Level (column 3) using the extrapolation factor of <math>40 \cdot \log(3/300) = -80 \text{ dB}</math></li> </ul>					
Frequency (MHz)	Peak E-Field @ 3m (dBμV/m)	Extrapolated E-Field Level @ 300m (dBμV/m)	Antenna Plane (H/V)	§ 15.209 (a) Limits @ 300m (dBμV/m)	Margin (dB)
0.125	53.85	-26.15	V	25.7	-51.9
0.125	51.23	-28.77	H	25.7	-54.5

**5.1.3.2. Harmonic/Spurious Emissions**

<b>Remarks:</b>					
<ul style="list-style-type: none"> <li>For frequency band 0.009- 0.490 MHz, the measured E-Field at 3m (column 2) will be extrapolated to 300m E-Field Level (column 3) using the extrapolation factor of <math>40 \cdot \log(3/300) = -80</math> dB</li> <li>For frequency bands 0.490-1.705 MHz and 1.705-30.0 MHz, the measured E-Field at 3m (column 2) will be extrapolated to 30m E-Field Level (column 3) using the extrapolation factor of <math>40 \cdot \log(3/30) = -40</math> dB</li> </ul>					
Frequency (MHz)	Peak E-Field @ 3m (dBμV/m)	Extrapolated E-Field Level (dBμV/m)	Antenna Plane (H/V)	§ 15.209 (a) Limits (dBμV/m)	Margin (dB)
0.009 - 0.490	*	*	H / V	*	*
0.490 - 1.705	*	*	H / V	*	*
1.705 - 30.0	*	*	H / V	*	*

\* No emissions or harmonics were detected within 20 dB of the limit.

**5.2. 20 dB BANDWIDTH [47 CFR 15.209 (a)]**

**5.2.1. Limit(s)**

Emission bandwidth shall not be located in the restricted bands in 15.205 and the frequency bands 54-72 MHz, 76-88 MHz, 174-216 MHz or 470-806 MHz.

**5.2.2. Method of Measurements**

The measurements were performed in accordance with Ultratech Test Procedures, File # ULTR P001-2004 and ANSI C63.4

**5.2.3. Test Data**

Channel Frequency	20 dB Bandwidth
125 kHz	1.21 kHz

See the following plot for details.

**Plot 5.2.3.1. 20 dB Bandwidth, Fc: 125 kHz**

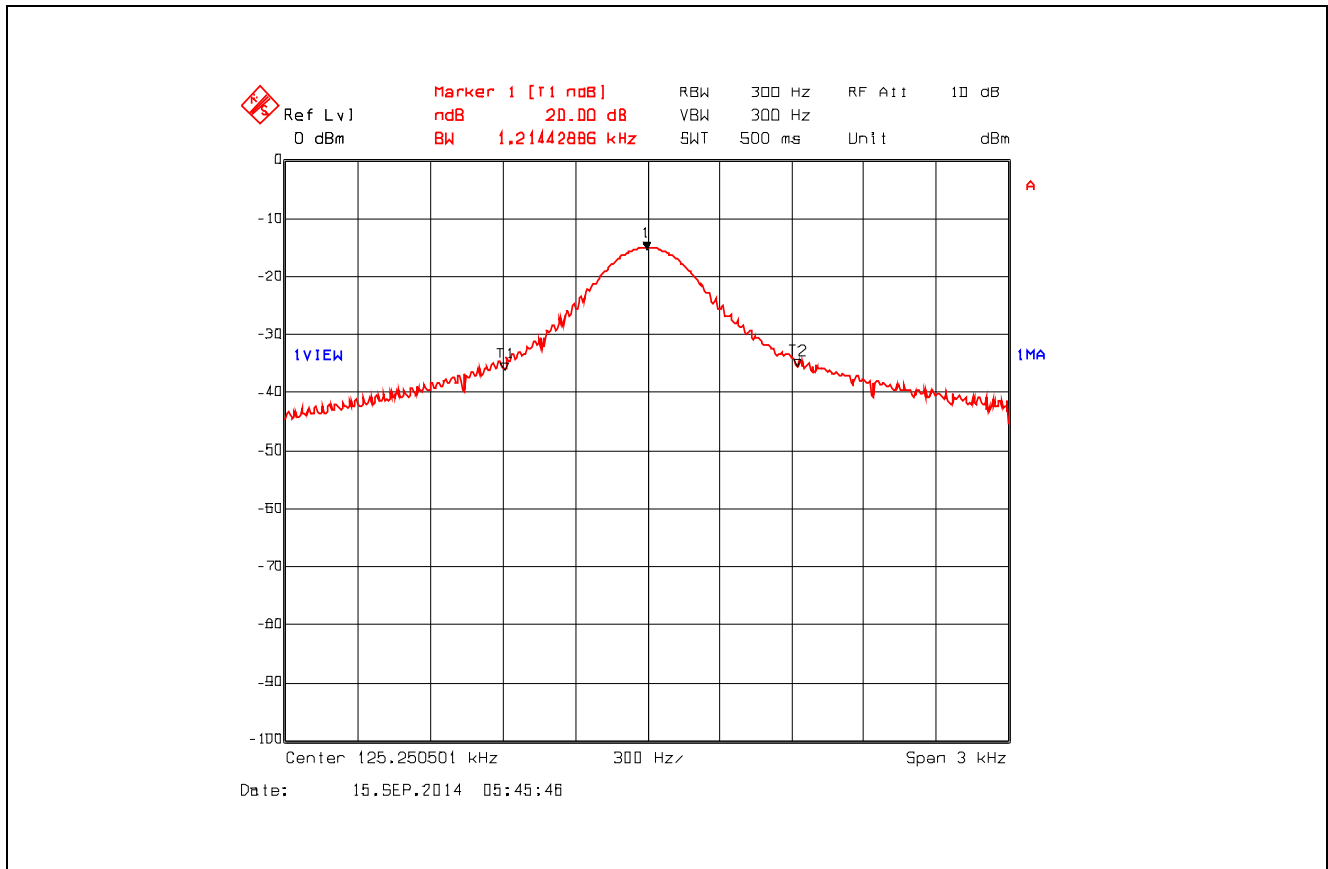

**EXHIBIT 6. TEST EQUIPMENT LIST**

Test Instruments	Manufacturer	Model No.	Serial No.	Frequency Range	Cal. Due Date
Spectrum Analyzer	Rohde & Schwarz	ESU40	100037	20 Hz – 40 GHz	05 Apr 2015
RF Amplifier	AH System	PAM-0118	225	20 MHz – 18 GHz	07 Apr 2015
Loop Antenna	EMCO	6502	9104-2611	10 kHz – 30 MHz	27 Aug 2015
Biconi-Log Antenna	ETS Lindgren	3142C	26873	26 – 3000 MHz	14 Apr 2015
Spectrum Analyzer	Rohde & Schwarz	FSEK30	100077	20 Hz – 40 GHz	08 Nov 2014

**ULTRATECH GROUP OF LABS**

3000 Bristol Circle, Oakville, Ontario, Canada L6H 6G4  
Tel. #: 905-829-1570, Fax. #: 905-829-8050, Email: vic@ultratech-labs.com, Website: <http://www.ultratech-labs.com>

File #: 16INVX028\_FCC15C209  
February 10, 2016

*All test results contained in this engineering test report are traceable to National Institute of Standards and Technology (NIST)*

**EXHIBIT 7. MEASUREMENT UNCERTAINTY**

The measurement uncertainties stated were calculated in accordance with the requirements of CISPR 16-4-2 @ IEC:2003 and JCGM 100:2008 (GUM 1995) – Guide to the Expression of Uncertainty in Measurement.

**7.1. RADIATED EMISSION MEASUREMENT UNCERTAINTY**

	<b>Radiated Emission Measurement Uncertainty @ 3m, Horizontal (30-1000 MHz):</b>	<b>Measured (dB)</b>	<b>Limit (dB)</b>
<b>u<sub>c</sub></b>	<b>Combined standard uncertainty:</b> $u_c(y) = \sqrt{\sum_{i=1}^m u_i^2(y)}$	<b>± 2.39</b>	<b>± 2.6</b>
<b>U</b>	<b>Expanded uncertainty U:</b> $U = 2u_c(y)$	<b>± 4.79</b>	<b>± 5.2</b>

	<b>Radiated Emission Measurement Uncertainty @ 3m, Vertical (30-1000 MHz):</b>	<b>Measured (dB)</b>	<b>Limit (dB)</b>
<b>u<sub>c</sub></b>	<b>Combined standard uncertainty:</b> $u_c(y) = \sqrt{\sum_{i=1}^m u_i^2(y)}$	<b>± 2.39</b>	<b>± 2.6</b>
<b>U</b>	<b>Expanded uncertainty U:</b> $U = 2u_c(y)$	<b>± 4.78</b>	<b>± 5.2</b>

	<b>Radiated Emission Measurement Uncertainty @ 3 m, Horizontal &amp; Vertical (1 – 18 GHz):</b>	<b>Measured (dB)</b>	<b>Limit (dB)</b>
<b>u<sub>c</sub></b>	<b>Combined standard uncertainty:</b> $u_c(y) = \sqrt{\sum_{i=1}^m u_i^2(y)}$	<b>± 1.87</b>	<b>Under consideration</b>
<b>U</b>	<b>Expanded uncertainty U:</b> $U = 2u_c(y)$	<b>± 3.75</b>	<b>Under consideration</b>