

FCC RF Test Report

APPLICANT : Kilpatrick LLC
EQUIPMENT : Tablet PC
MODEL NAME : C7U3RE
FCC ID : S2F-6740
STANDARD : 47 CFR Part 2, 27
CLASSIFICATION : PCS Licensed Transmitter (PCB)

The product was completely test on Sep. 14, 2013.. We, SPORTON INTERNATIONAL INC., would like to declare that the tested sample has been evaluated in accordance with the procedures given in ANSI / TIA / EIA-603-C-2004 and shown compliance with the applicable technical standards.

The test results in this report apply exclusively to the tested model / sample. Without written approval of SPORTON INTERNATIONAL INC., the test report shall not be reproduced except in full.



Reviewed by: Joseph Lin / Supervisor

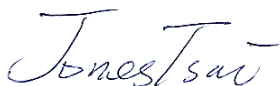

Approved by: Jones Tsai / Manager



SPORTON INTERNATIONAL INC.

No. 52, Hwa Ya 1st Rd., Hwa Ya Technology Park, Kwei-Shan Hsiang, Tao Yuan Hsien, Taiwan, R.O.C.

Report No. : FG332726-07B
Report Version : Rev. 02
Page Number : 1 of 152

TABLE OF CONTENTS

REVISION HISTORY.....	3
SUMMARY OF TEST RESULT	4
1 GENERAL DESCRIPTION	5
1.1 Applicant	5
1.2 Feature of Equipment Under Test	5
1.3 Product Specification of Equipment Under Test.....	5
1.4 Modification of EUT	5
1.5 Emission Designator.....	6
1.6 Testing Site.....	7
1.7 Applied Standards	7
2 TEST CONFIGURATION OF EQUIPMENT UNDER TEST.....	8
2.1 Test Mode.....	8
2.2 Connection Diagram of Test System.....	9
2.3 Support Unit used in test configuration and system	10
2.4 Measurement Results Explanation Example.....	10
3 TEST RESULT.....	11
3.1 Conducted Output Power Measurement and ERP/EIRP Measurement	11
3.2 Peak-to-Average Ratio	20
3.3 Occupied Bandwidth.....	30
3.4 Conducted Band Edge Measurement	47
3.5 Conducted Spurious Emission Measurement	81
3.6 Radiated Spurious Emission Measurement	126
3.7 Frequency Stability Measurement.....	144
4 LIST OF MEASURING EQUIPMENT	151
5 UNCERTAINTY OF EVALUATION	152

SUMMARY OF TEST RESULT

Report Section	FCC Rule	Description	Limit	Result	Remark
3.1	§2.1046	Conducted Output Power & E.I.R.P / E.R.P	Reporting Only & Band 4 < 1W (EIRP) Band 13 < 3W (ERP)	PASS	-
3.2	27.53(d)(5)	Peak-to-Average Ratio	<13 dB	PASS	-
3.3	§2.1049 §27.53(h)(3)	Occupied Bandwidth	Reporting Only	PASS	-
3.4	§2.1049 §27.53(c)(h)	Conducted Band Edge Measurement (Band 4) (Band 13)	< 43+10log ₁₀ (P[Watts])	PASS	-
3.5	§2.1051 §27.53(c)(h)	Conducted Spurious Emission (Band 4) (Band 13)	< 43+10log ₁₀ (P[Watts])	PASS	-
3.6	§2.1053 §27.53(c)(h)	Radiated Spurious Emission (Band 4) (Band 13)	< 43+10log ₁₀ (P[Watts])	PASS	Under limit 30.01 dB at 6888.000 MHz
3.7	§2.1055 §27.54	Frequency Stability Temperature & Voltage	< 2.5 ppm	PASS	

1 General Description

1.1 Applicant

Kilpatrick LLC
102 S. Tejon Street
Suite 1100
Colorado Springs, Colorado 80903

1.2 Feature of Equipment Under Test

Product Feature	
Equipment	Tablet PC
Model Name	C7U3RE
FCC ID	S2F-6740
EUT supports Radios application	GSM/EGPRS/WCDMA/HSPA/LTE WLAN 11b/g/n (HT20), WLAN 11a/n (HT20/HT40) Bluetooth v3.0

Remark: The above EUT's information was declared by manufacturer. Please refer to the specifications or user's manual for more detailed description.

1.3 Product Specification of Equipment Under Test

Product Specification subjective to this standard	
Tx Frequency	LTE Band 4 : 1710.7 MHz ~ 1754.3 MHz LTE Band 13 : 779.5 MHz ~ 784.5 MHz
Rx Frequency	LTE Band 4 : 2110.7 MHz ~ 2154.3 MHz LTE Band 13 : 748.5 MHz ~ 753.5 MHz
Bandwidth	1.4MHz / 3MHz / 5MHz / 10MHz / 15MHz / 20MHz (Band 4) 5MHz / 10MHz (Band 13)
Maximum Output Power to Antenna	LTE Band 4 : 23.70 dBm / 0.23 W LTE Band 13 : 22.90 dBm / 0.19 W
Antenna Type	Fixed Internal Antenna
Antenna Gain	LTE Band 4 : 0.00 dBi LTE Band 13 : 1.70 dBi
Type of Modulation	QPSK / 16QAM

1.4 Modification of EUT

No modifications are made to the EUT during all test items.

1.5 Emission Designator

FCC Rule	System	Type of Modulation	BW	Emission Designator	Frequency Tolerance (% , Hz, ppm)	Maximum ERP/EIRP
Part 27	LTE Band 4	QPSK	1.4 MHz	1M10G7D	0.005 ppm	0.23 W
Part 27	LTE Band 4	16QAM	1.4 MHz	1M10D7W	0.005 ppm	0.19 W
Part 27	LTE Band 4	QPSK	3 MHz	2M74G7D	0.004 ppm	0.23 W
Part 27	LTE Band 4	16QAM	3 MHz	2M74D7W	0.004 ppm	0.19 W
Part 27	LTE Band 4	QPSK	5MHz	4M52G7D	0.004 ppm	0.23 W
Part 27	LTE Band 4	16QAM	5MHz	4M52D7W	0.005 ppm	0.19 W
Part 27	LTE Band 4	QPSK	10MHz	9M12G7D	0.004 ppm	0.23 W
Part 27	LTE Band 4	16QAM	10MHz	9M08D7W	0.004 ppm	0.19 W
Part 27	LTE Band 4	QPSK	15MHz	13M5G7D	0.004 ppm	0.23 W
Part 27	LTE Band 4	16QAM	15MHz	13M5D7W	0.005 ppm	0.19 W
Part 27	LTE Band 4	QPSK	20MHz	18M6G7D	0.004 ppm	0.23 W
Part 27	LTE Band 4	16QAM	20MHz	18M6D7W	0.004 ppm	0.19 W
Part 27	LTE Band 13	QPSK	5MHz	4M52G7D	0.010 ppm	0.18 W
Part 27	LTE Band 13	16QAM	5MHz	4M52D7W	0.008 ppm	0.14 W
Part 27	LTE Band 13	QPSK	10MHz	9M16G7D	0.010 ppm	0.17 W
Part 27	LTE Band 13	16QAM	10MHz	9M08D7W	0.009 ppm	0.14 W

1.6 Testing Site

Test Site	SPORTON INTERNATIONAL INC.		
Test Site Location	No. 52, Hwa Ya 1 st Rd., Hwa Ya Technology Park, Kwei-Shan Hsiang, Tao Yuan Hsien, Taiwan, R.O.C. TEL: +886-3-327-3456 FAX: +886-3-328-4978		
Test Site No.	Sporton Site No.		FCC Registration No.
	TH02-HY	03CH07-HY	722060

1.7 Applied Standards

According to the specifications of the manufacturer, the EUT must comply with the requirements of the following standards:

- ♦ 47 CFR Part 2, 27
- ♦ ANSI / TIA / EIA-603-C-2004
- ♦ FCC KDB 412172 D01 Determining ERP and ERIP v01
- ♦ FCC KDB 971168 D01 Power Meas. License Digital Systems v02r01

Remark:

1. All test items were verified and recorded according to the standards and without any deviation during the test.
2. This EUT has also been tested and complied with the requirements of FCC Part 15, Subpart B, recorded in a separate test report.

2 Test Configuration of Equipment Under Test

2.1 Test Mode

During all testing, EUT is in link mode with base station emulator at maximum power level. The spurious emission measurements were carried out in semi-anechoic chamber with 3-meter test range, and EUT is rotated on three test planes to find out the worst emission.

Frequency range investigated for radiated emission: 30MHz to 10th harmonic.

Test Cases						
	Test Item	Band	Bandwidth	Modulation	RB #	Test Channel
Conducted	Max. Output Power	4	1.4MHz / 3MHz / 5MHz / 10MHz / 15MHz / 20MHz	QPSK/16QAM	1/Half/Full	L/M/H
		13	5MHz	QPSK/16QAM	1/Half/Full	L/M/H
			10MHz	QPSK/16QAM	1/Half/Full	M
	Peak-to-Average Ratio	4	1.4MHz / 3MHz / 5MHz / 10MHz / 15MHz / 20MHz	QPSK/16QAM	Full	M
		13	5MHz / 10MHz	QPSK/16QAM	Full	M
	26dB and 99% Bandwidth	4	1.4MHz / 3MHz / 5MHz / 10MHz / 15MHz / 20MHz	QPSK/16QAM	Full	M
		13	5MHz / 10MHz	QPSK/16QAM	Full	M
	Conducted Band Edge	4	1.4MHz / 3MHz / 5MHz / 10MHz / 15MHz / 20MHz	QPSK/16QAM	1RB / Full	L/H
						13
		13	10MHz	QPSK/16QAM	1RB / Full	M
	Conducted Spurious Emission	4	1.4MHz / 3MHz / 5MHz / 10MHz / 15MHz / 20MHz	QPSK/16QAM	1RB	L/M/H
						13
		13	10MHz	QPSK/16QAM	1RB	M

Test Cases						
	Frequency Stability	4	1.4MHz / 3MHz / 5MHz / 10MHz / 15MHz / 20MHz	QPSK/16QAM	Full	M
		13	5MHz / 10MHz	QPSK/16QAM	Full	M
Radiated	E.I.R.P / E.R.P	4	1.4MHz / 3MHz / 5MHz / 10MHz / 15MHz / 20MHz	QPSK/16QAM	1RB	L/M/H
		13	5MHz	QPSK/16QAM	1RB	L/M/H
	10MHz		QPSK/16QAM	1RB	M	
	Radiated Spurious Emission	4	1.4MHz / 3MHz / 5MHz / 10MHz / 15MHz / 20MHz	QPSK/16QAM	1RB	M
13		5MHz / 10MHz	QPSK/16QAM	1RB	M	

Note: The spurious emission was performed by conducted and radiated methods. From conducted spurious emission measurement (QPSK and 16QAM), the modulation related spurious emission out of the band was not identified and the radiated spurious emissions results on 16QAM were not worse than QSPK mode during pretested. Since MPR is implemented, 1RB-QPSK results in highest RF power, therefore it's chosen for final radiated spurious emissions measurement.

2.2 Connection Diagram of Test System

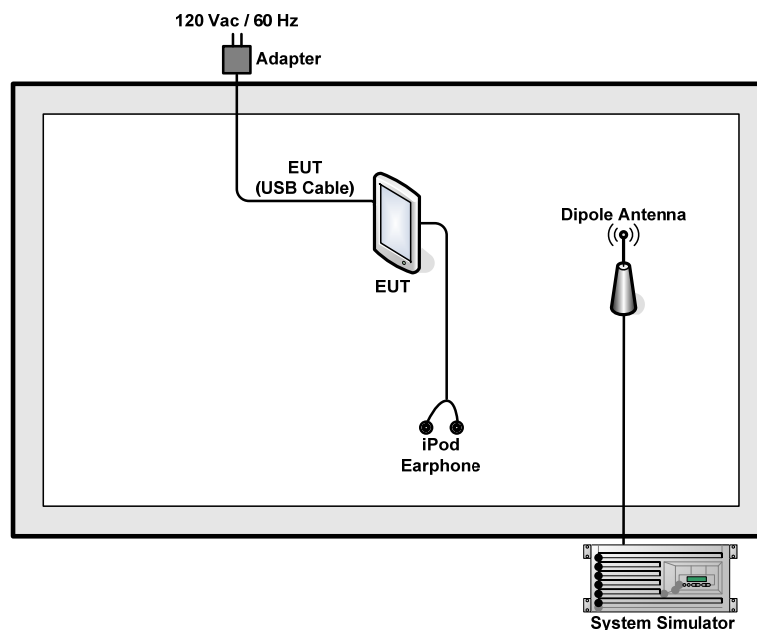

2.3 Support Unit used in test configuration and system

Item	Equipment	Trade Name	Model No.	FCC ID	Data Cable	Power Cord
1.	System Simulator	Anritsu	MT8820C	N/A	N/A	Unshielded, 1.8 m
2.	iPod Earphone	Apple	N/A	N/A	Unshielded, 1.0 m	N/A
3.	Adapter	Foxlink	PE98ED	Verification	N/A	N/A

2.4 Measurement Results Explanation Example

For all conducted test items:

The offset level is set in the spectrum analyzer to compensate the RF cable loss and attenuator factor between EUT conducted output port and spectrum analyzer. With the offset compensation, the spectrum analyzer reading level is exactly the EUT RF output level.

The spectrum analyzer offset is derived from RF cable loss and attenuator factor.

Offset = RF cable loss + attenuator factor.

Following shows an offset computation example with cable loss 4.2 dB and 10dB attenuator.

Example :

$$\begin{aligned} \text{Offset(dB)} &= \text{RF cable loss(dB)} + \text{attenuator factor(dB)}. \\ &= 4.2 + 10 = 14.2 \text{ (dB)} \end{aligned}$$

3 Test Result

3.1 Conducted Output Power Measurement and ERP/EIRP Measurement

3.1.1 Description of the Conducted Output Power Measurement and ERP/EIRP Measurement

A base station simulator was used to establish communication with the EUT. Its parameters were set to transmit the maximum power on the EUT. The measured power in the radio frequency on the transmitter output terminals shall be reported.

The ERP of mobile transmitters must not exceed 3 Watts for LTE Band 13.

The EIRP of mobile transmitters must not exceed 1 Watts for LTE Band 4.

According to KDB 412172 D01 Power Approach,

$EIRP = P_T + G_T - L_C$, $ERP = EIRP - 2.15$, where

P_T = transmitter output power in dBm

G_T = gain of the transmitting antenna in dBi

L_C = signal attenuation in the connecting cable between the transmitter and antenna in dB

3.1.2 Measuring Instruments

Measuring equipment is listed in the section 4 of this test report.

3.1.3 Test Procedures

1. The transmitter output port was connected to base station.
2. Set EUT at maximum power through base station.
3. Select lowest, middle, and highest channels for each band and different modulation.

3.1.4 Test Setup

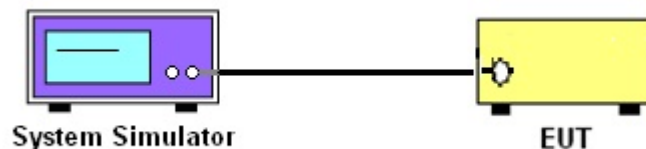

3.1.5 Test Result of Conducted Output Power

<LTE Band 4 Conducted Power>

BW [MHz]	Modulation	RB Size	RB Offset	Power (dBm) Low Ch. / Freq.	Power (dBm) Middle Ch. / Freq.	Power (dBm) High Ch. / Freq.
Channel				20050	20175	20300
Frequency (MHz)				1720	1732.5	1745
20	QPSK	1	0	23.4	23.5	23.6
20	QPSK	1	49	23.5	23.5	23.6
20	QPSK	1	99	23.5	23.4	23.6
20	QPSK	50	0	22.2	22.3	22.2
20	QPSK	50	24	22.3	22.3	22.2
20	QPSK	50	49	22.3	22.3	22.2
20	QPSK	100	0	22.3	22.4	22.3
20	16QAM	1	0	21.8	22.8	22.4
20	16QAM	1	49	21.9	22.8	22.5
20	16QAM	1	99	21.9	22.8	22.5
20	16QAM	50	0	21.3	21.3	21.2
20	16QAM	50	24	21.4	21.2	21.3
20	16QAM	50	49	21.4	21.3	21.3
20	16QAM	100	0	21.3	21.3	21.3
Channel				20025	20175	20325
Frequency (MHz)				1717.5	1732.5	1747.5
15	QPSK	1	0	23.5	23.6	23.5
15	QPSK	1	37	23.6	23.5	23.6
15	QPSK	1	74	23.6	23.5	23.6
15	QPSK	36	0	22.2	22.2	22.3
15	QPSK	36	18	22.2	22.3	22.2
15	QPSK	36	37	22.3	22.2	22.2
15	QPSK	75	0	22.2	22.2	22.2
15	16QAM	1	0	22.7	22.8	22.7
15	16QAM	1	37	22.8	22.8	22.9
15	16QAM	1	74	22.8	22.7	22.7
15	16QAM	36	0	21.3	21.4	21.3
15	16QAM	36	18	21.3	21.3	21.3
15	16QAM	36	37	21.3	21.3	21.3
15	16QAM	75	0	21.2	21.2	21.1

BW [MHz]	Modulation	RB Size	RB Offset	Power (dBm) Low Ch. / Freq.	Power (dBm) Middle Ch. / Freq.	Power (dBm) High Ch. / Freq.
Channel				20000	20175	20350
Frequency (MHz)				1715	1732.5	1750
10	QPSK	1	0	23.4	23.5	23.4
10	QPSK	1	24	23.5	23.5	23.4
10	QPSK	1	49	23.6	23.5	23.3
10	QPSK	25	0	22.3	22.4	22.4
10	QPSK	25	12	22.3	22.4	22.4
10	QPSK	25	24	22.4	22.4	22.3
10	QPSK	50	0	22.1	22.3	22.2
10	16QAM	1	0	22.6	21.9	22.2
10	16QAM	1	24	22.7	21.9	22.1
10	16QAM	1	49	22.8	21.9	22.1
10	16QAM	25	0	21.4	21.5	21.5
10	16QAM	25	12	21.4	21.5	21.5
10	16QAM	25	24	21.5	21.5	21.4
10	16QAM	50	0	21.2	21.3	21.2
Channel				19975	20175	20375
Frequency (MHz)				1712.5	1732.5	1752.5
5	QPSK	1	0	23.5	23.7	23.5
5	QPSK	1	12	23.5	23.7	23.5
5	QPSK	1	24	23.6	23.6	23.5
5	QPSK	12	0	22.5	22.6	22.5
5	QPSK	12	6	22.5	22.6	22.5
5	QPSK	12	11	22.5	22.6	22.4
5	QPSK	25	0	22.3	22.4	22.3
5	16QAM	1	0	22.7	22.6	22.6
5	16QAM	1	12	22.7	22.6	22.6
5	16QAM	1	24	22.7	22.6	22.5
5	16QAM	12	0	21.6	21.6	22.6
5	16QAM	12	6	21.6	21.6	21.6
5	16QAM	12	11	21.6	21.7	21.5
5	16QAM	25	0	21.6	21.5	21.4

BW [MHz]	Modulation	RB Size	RB Offset	Power (dBm) Low Ch. / Freq.	Power (dBm) Middle Ch. / Freq.	Power (dBm) High Ch. / Freq.
Channel				19965	20175	20385
Frequency (MHz)				1711.5	1732.5	1753.5
3	QPSK	1	0	23.6	23.6	23.5
3	QPSK	1	7	23.5	23.6	23.5
3	QPSK	1	14	23.6	23.5	23.5
3	QPSK	8	0	22.6	22.6	22.5
3	QPSK	8	4	22.5	22.6	22.5
3	QPSK	8	7	22.6	22.6	22.5
3	QPSK	15	0	22.5	22.6	22.5
3	16QAM	1	0	22.7	22.0	22.6
3	16QAM	1	7	22.8	22.0	22.7
3	16QAM	1	14	22.8	21.9	22.7
3	16QAM	8	0	21.6	21.5	21.5
3	16QAM	8	4	21.6	21.6	21.5
3	16QAM	8	7	21.6	21.5	21.6
3	16QAM	15	0	21.6	21.5	21.5
Channel				19957	20175	20393
Frequency (MHz)				1710.7	1732.5	1754.3
1.4	QPSK	1	0	23.6	23.6	23.5
1.4	QPSK	1	2	23.5	23.5	23.4
1.4	QPSK	1	5	23.6	23.6	23.5
1.4	QPSK	3	0	23.6	23.6	23.5
1.4	QPSK	3	1	23.6	23.5	23.5
1.4	QPSK	3	2	23.6	23.6	23.5
1.4	QPSK	6	0	22.5	22.7	22.5
1.4	16QAM	1	0	22.8	22.8	22.6
1.4	16QAM	1	2	22.8	22.7	22.5
1.4	16QAM	1	5	22.8	22.8	22.6
1.4	16QAM	3	0	22.6	22.6	22.6
1.4	16QAM	3	1	22.6	22.7	22.4
1.4	16QAM	3	2	22.6	22.6	22.4
1.4	16QAM	6	0	21.4	21.4	21.3

<LTE Band 13 Conducted Power>

BW [MHz]	Modulation	RB Size	RB Offset	Power (dBm) Low Ch. / Freq.	Power (dBm) Middle Ch. / Freq.	Power (dBm) High Ch. / Freq.
Channel					23230	
Frequency (MHz)					782	
10	QPSK	1	0		22.8	
10	QPSK	1	24		22.7	
10	QPSK	1	49		22.8	
10	QPSK	25	0		21.6	
10	QPSK	25	12		21.7	
10	QPSK	25	24		21.7	
10	QPSK	50	0		21.5	
10	16QAM	1	0		21.8	
10	16QAM	1	24		21.8	
10	16QAM	1	49		21.8	
10	16QAM	25	0		20.5	
10	16QAM	25	12		20.6	
10	16QAM	25	24		20.6	
10	16QAM	50	0		20.4	
Channel				23205	23230	23255
Frequency (MHz)				779.5	782	784.5
5	QPSK	1	0	22.8	22.6	22.6
5	QPSK	1	12	22.7	22.7	22.7
5	QPSK	1	24	22.8	22.7	22.7
5	QPSK	12	0	22.8	21.7	21.7
5	QPSK	12	6	22.7	21.7	21.7
5	QPSK	12	11	22.9	21.6	21.8
5	QPSK	25	0	21.6	21.6	21.6
5	16QAM	1	0	21.7	21.7	21.6
5	16QAM	1	12	21.8	21.7	21.8
5	16QAM	1	24	21.8	21.8	21.8
5	16QAM	12	0	20.7	20.7	20.7
5	16QAM	12	6	20.8	20.7	20.7
5	16QAM	12	11	20.7	20.7	20.8
5	16QAM	25	0	20.5	20.5	20.5

Note: maximum average power for LTE.

3.1.6 Test Result of Conducted Output Power and ERP/EIRP

LTE Band 4 ($G_T - L_C = 0.00$ dB)						
Modes	LTE Band 4 (QPSK, BW=1.4M)			LTE Band 4 (16QAM, BW=1.4M)		
Channel	19957 (Low)	20175 (Mid)	20393 (High)	19957 (Low)	20175 (Mid)	20393 (High)
Frequency (MHz)	1710.7	1732.5	1754.3	1710.7	1732.5	1754.3
Conducted Power (dBm)	23.6	23.6	23.5	22.8	22.8	22.6
Conducted Power (Watts)	0.23	0.23	0.22	0.19	0.19	0.18
EIRP(dBm)	23.60	23.60	23.50	22.80	22.80	22.60
EIRP(Watts)	0.23	0.23	0.22	0.19	0.19	0.18

LTE Band 4 ($G_T - L_C = 0.00$ dB)						
Modes	LTE Band 4 (QPSK, BW=3M)			LTE Band 4 (16QAM, BW=3M)		
Channel	19965(Low)	20175 (Mid)	20385 (High)	19965(Low)	20175 (Mid)	20385 (High)
Frequency (MHz)	1711.5	1732.5	1753.5	1711.5	1732.5	1753.5
Conducted Power (dBm)	23.6	23.6	23.5	22.8	22.0	22.7
Conducted Power (Watts)	0.23	0.23	0.22	0.19	0.16	0.19
EIRP(dBm)	23.60	23.60	23.50	22.80	22.00	22.70
EIRP(Watts)	0.23	0.23	0.22	0.19	0.16	0.19

LTE Band 4 ($G_T - L_C = 0.00$ dB)						
Modes	LTE Band 4 (QPSK,BW=5M)			LTE Band 4 (16QAM,BW=5M)		
Channel	19975(Low)	20175 (Mid)	20375 (High)	19975(Low)	20175 (Mid)	20375 (High)
Frequency (MHz)	1712.5	1732.5	1752.5	1712.5	1732.5	1752.5
Conducted Power (dBm)	23.6	23.7	23.5	22.7	22.6	22.6
Conducted Power (Watts)	0.23	0.23	0.22	0.19	0.18	0.18
EIRP(dBm)	23.60	23.70	23.50	22.70	22.60	22.60
EIRP(Watts)	0.23	0.23	0.22	0.19	0.18	0.18

LTE Band 4 ($G_T - L_C = 0.00$ dB)						
Modes	LTE Band 4 (QPSK,BW=10M)			LTE Band 4 (16QAM,BW=10M)		
Channel	20000 (Low)	20175 (Mid)	20350 (High)	20000 (Low)	20175 (Mid)	20350 (High)
Frequency (MHz)	1715	1732.5	1750	1715	1732.5	1750
Conducted Power (dBm)	23.6	23.5	23.4	22.8	21.9	22.2
Conducted Power (Watts)	0.23	0.22	0.22	0.19	0.15	0.17
EIRP(dBm)	23.60	23.50	23.40	22.80	21.90	22.20
EIRP(Watts)	0.23	0.22	0.22	0.19	0.15	0.17

LTE Band 4 ($G_T - L_C = 0.00$ dB)						
Modes	LTE Band 4 (QPSK, BW=15M)			LTE Band 4 (16QAM, BW=15M)		
Channel	20025 (Low)	20175 (Mid)	20325 (High)	20025 (Low)	20175 (Mid)	20325 (High)
Frequency (MHz)	1717.5	1732.5	1747.5	1717.5	1732.5	1747.5
Conducted Power (dBm)	23.6	23.6	23.6	22.8	22.8	22.9
Conducted Power (Watts)	0.23	0.23	0.23	0.19	0.19	0.19
EIRP(dBm)	23.60	23.60	23.60	22.80	22.80	22.90
EIRP(Watts)	0.23	0.23	0.23	0.19	0.19	0.19

LTE Band 4 ($G_T - L_C = 0.00$ dB)						
Modes	LTE Band 4 (QPSK, BW=20M)			LTE Band 4 (16QAM, BW=20M)		
Channel	20050 (Low)	20175 (Mid)	20300 (High)	20050 (Low)	20175 (Mid)	20300 (High)
Frequency (MHz)	1720	1732.5	1745	1720	1732.5	1745
Conducted Power (dBm)	23.5	23.5	23.6	21.9	22.8	22.5
Conducted Power (Watts)	0.22	0.22	0.23	0.15	0.19	0.18
EIRP(dBm)	23.50	23.50	23.60	21.90	22.80	22.50
EIRP(Watts)	0.22	0.22	0.23	0.15	0.19	0.18

LTE Band 13 ($G_T - L_C = 1.70$ dB)						
Modes	LTE Band 13 (QPSK, BW=5M)			LTE Band 13 (16QAM, BW=5M)		
Channel	23205 (Low)	23230 (Mid)	23255 (High)	23205 (Low)	23230 (Mid)	23255 (High)
Frequency (MHz)	779.5	782	784.5	779.5	782	784.5
Conducted Power (dBm)	22.9	22.7	22.7	21.8	21.8	21.8
Conducted Power (Watts)	0.19	0.19	0.19	0.15	0.15	0.15
ERP(dBm)	22.45	22.25	22.25	21.35	21.35	21.35
ERP(Watts)	0.18	0.17	0.17	0.14	0.14	0.14

LTE Band 13 ($G_T - L_C = 1.70$ dB)		
Modes	LTE Band 13 (QPSK, BW=10M)	LTE Band 13 (16QAM, BW=10M)
Channel	23230 (Mid)	23230 (Mid)
Frequency (MHz)	782	782
Conducted Power (dBm)	22.8	21.8
Conducted Power (Watts)	0.19	0.15
ERP(dBm)	22.35	21.35
ERP(Watts)	0.17	0.14

3.2 Peak-to-Average Ratio

3.2.1 Description of the PAR Measurement

Power Complementary Cumulative Distribution Function (CCDF) curves provide a means for characterizing the power peaks of a digitally modulated signal on a statistical basis. A CCDF curve depicts the probability of the peak signal amplitude exceeding the average power level. Most contemporary measurement instrumentation include the capability to produce CCDF curves for an input signal provided that the instrument's resolution bandwidth can be set wide enough to accommodate the entire input signal bandwidth. In measuring transmissions in this band using an average power technique, the peak-to-average ratio (PAR) of the transmission may not exceed 13 dB.

3.2.2 Measuring Instruments

Measuring equipment is listed in the section 4 of this test report.

3.2.3 Test Procedures

1. The EUT was connected to Spectrum Analyzer and Base Station via power divider.
2. For LTE operating modes:
 - a. Set the CCDF (Complementary Cumulative Distribution Function) option in spectrum analyzer.
 - b. The highest RF powers were measured and recorded the maximum PAPR level associated with a probability of 0.1 %.
3. Record the deviation as Peak to Average Ratio.

3.2.4 Test Setup

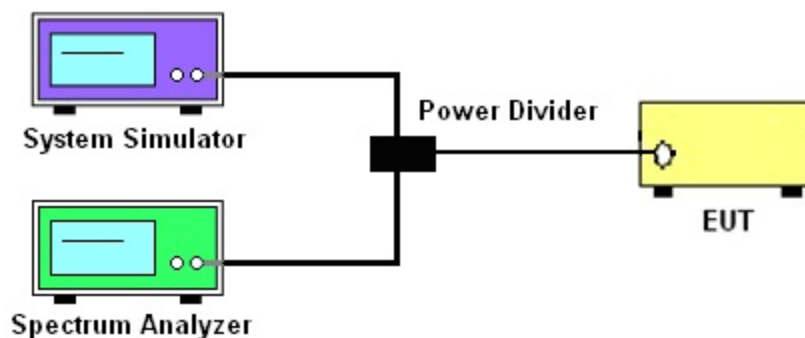

3.2.5 Test Result of Peak-to-Average Ratio

Modes	LTE Band 4			
BW / Mod.	1.4MHz / QPSK	1.4MHz / 16QAM	3MHz / QPSK	3MHz / 16QAM
Peak-to-Average Ratio (dB)	6.06	6.70	6.03	6.70
BW / Mod.	5MHz / QPSK	5MHz / 16QAM	10MHz / QPSK	10MHz / 16QAM
Peak-to-Average Ratio (dB)	5.93	6.51	5.83	6.47
BW / Mod.	15MHz / QPSK	15MHz / 16QAM	20MHz / QPSK	20MHz / 16QAM
Peak-to-Average Ratio (dB)	5.83	6.51	5.77	6.54

Modes	LTE Band 13			
BW / Mod.	5MHz / QPSK	5MHz / 16QAM	10MHz / QPSK	10MHz / 16QAM
Peak-to-Average Ratio (dB)	5.87	6.57	5.93	6.54

Note:

The maximum RB configurations of the PAPR summary as below:

BW1.4MHz RB setting : RB Size 6, RB offset 0

BW3.0MHz RB setting : RB Size 15, RB offset 0

BW5.0MHz RB setting : RB Size 25, RB offset 0

BW10MHz RB setting : RB Size 50, RB offset 0

BW15MHz RB setting : RB Size 75, RB offset 0

BW20MHz RB setting : RB Size 100, RB offset 0

3.2.6 Peak to Average Power Ratio

Peak-to-Average Ratio on LTE Band 4 1.4MHz / QPSK

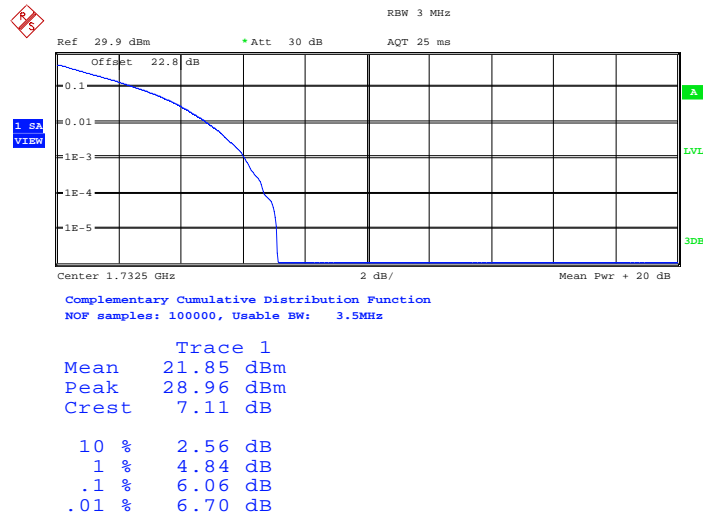

Date: 30.JUL.2013 16:13:27

Peak-to-Average Ratio on LTE Band 4 1.4MHz / 16QAM

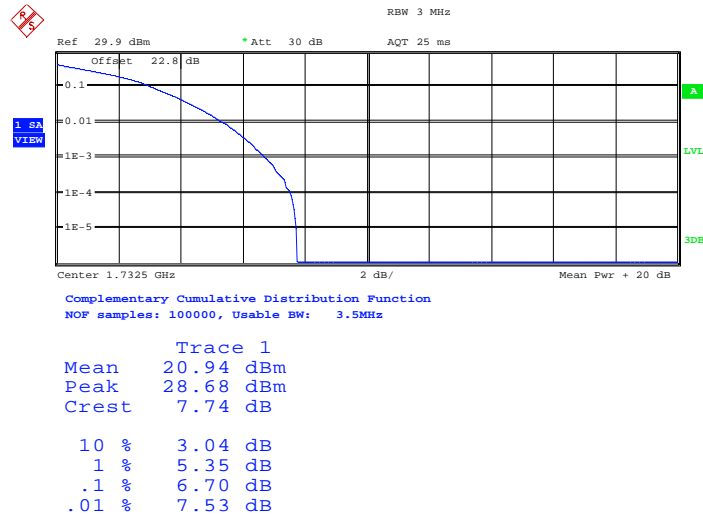

Date: 30.JUL.2013 16:13:54

Peak-to-Average Ratio on LTE Band 4 3MHz / QPSK

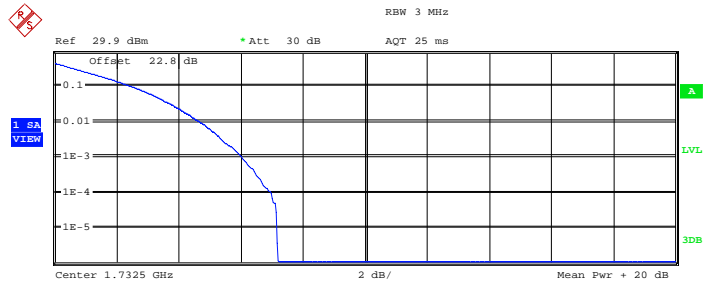

Complementary Cumulative Distribution Function
 NOF samples: 100000, Usable BW: 3.5MHz

Trace 1	
Mean	21.72 dBm
Peak	28.89 dBm
Crest	7.17 dB
10 %	2.50 dB
1 %	4.68 dB
.1 %	6.03 dB
.01 %	6.96 dB

Date: 30.JUL.2013 16:14:30

Peak-to-Average Ratio on LTE Band 4 3MHz / 16QAM

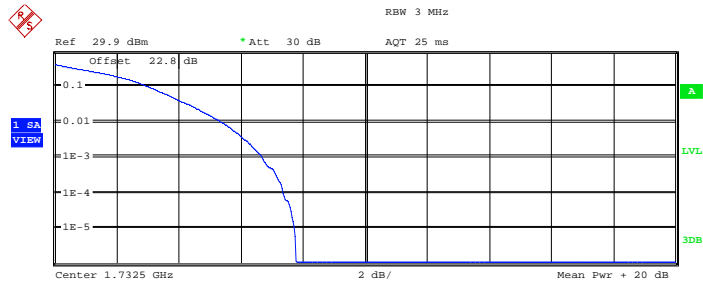

Complementary Cumulative Distribution Function
 NOF samples: 100000, Usable BW: 3.5MHz

Trace 1	
Mean	20.83 dBm
Peak	28.61 dBm
Crest	7.78 dB
10 %	3.01 dB
1 %	5.38 dB
.1 %	6.70 dB
.01 %	7.37 dB

Date: 30.JUL.2013 16:14:08

Peak-to-Average Ratio on LTE Band 4 5MHz / QPSK

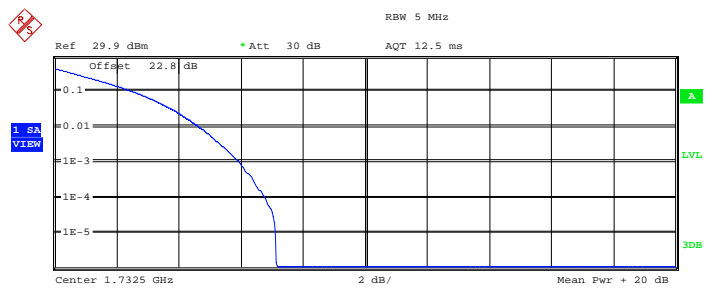

Complementary Cumulative Distribution Function
 NOF samples: 100000, Usable BW: 7.1MHz

Trace 1	
Mean	21.47 dBm
Peak	28.61 dBm
Crest	7.14 dB
10 %	2.53 dB
1 %	4.65 dB
.1 %	5.93 dB
.01 %	6.76 dB

Date: 30.JUL.2013 16:14:51

Peak-to-Average Ratio on LTE Band 4 5MHz / 16QAM

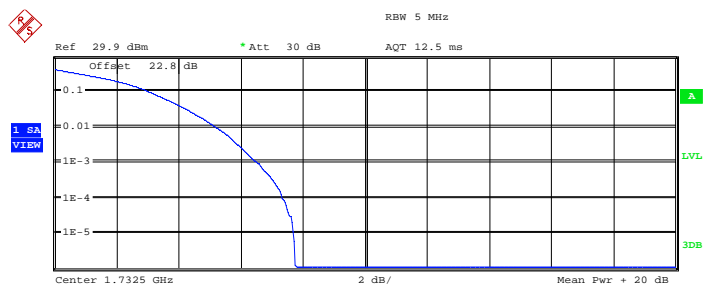

Complementary Cumulative Distribution Function
 NOF samples: 100000, Usable BW: 7.1MHz

Trace 1	
Mean	20.65 dBm
Peak	28.40 dBm
Crest	7.75 dB
10 %	3.04 dB
1 %	5.19 dB
.1 %	6.51 dB
.01 %	7.34 dB

Date: 30.JUL.2013 16:15:07

Peak-to-Average Ratio on LTE Band 4 10MHz / QPSK

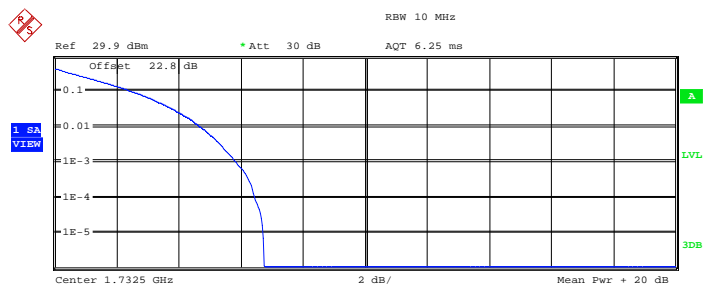

Complementary Cumulative Distribution Function
 NOF samples: 100000, Usable BW: 11.2MHz

Trace 1	
Mean	21.80 dBm
Peak	28.55 dBm
Crest	6.74 dB
10 %	2.50 dB
1 %	4.68 dB
.1 %	5.83 dB
.01 %	6.44 dB

Date: 30.JUL.2013 16:15:59

Peak-to-Average Ratio on LTE Band 4 10MHz / 16QAM

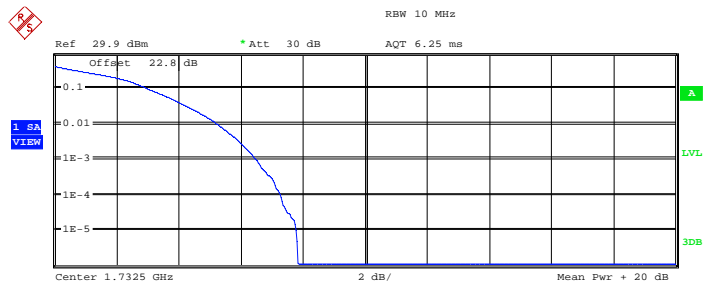

Complementary Cumulative Distribution Function
 NOF samples: 100000, Usable BW: 11.2MHz

Trace 1	
Mean	20.85 dBm
Peak	28.69 dBm
Crest	7.84 dB
10 %	3.01 dB
1 %	5.22 dB
.1 %	6.47 dB
.01 %	7.28 dB

Date: 30.JUL.2013 16:15:35

Peak-to-Average Ratio on LTE Band 4 15MHz / QPSK

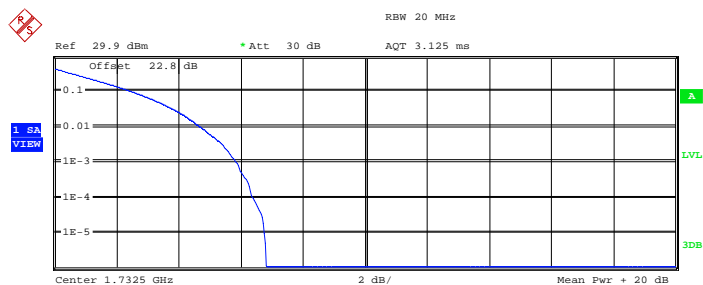

Complementary Cumulative Distribution Function
 NOF samples: 100000, Usable BW: 23.7MHz

Trace 1	
Mean	21.34 dBm
Peak	28.16 dBm
Crest	6.82 dB
10 %	2.50 dB
1 %	4.68 dB
.1 %	5.83 dB
.01 %	6.38 dB

Date: 30.JUL.2013 16:16:25

Peak-to-Average Ratio on LTE Band 4 15MHz / 16QAM

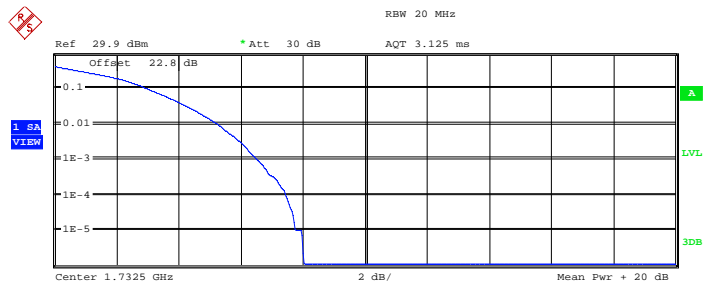

Complementary Cumulative Distribution Function
 NOF samples: 100000, Usable BW: 23.7MHz

Trace 1	
Mean	20.57 dBm
Peak	28.59 dBm
Crest	8.02 dB
10 %	2.98 dB
1 %	5.26 dB
.1 %	6.51 dB
.01 %	7.44 dB

Date: 30.JUL.2013 16:17:18

Peak-to-Average Ratio on LTE Band 4 20MHz / QPSK

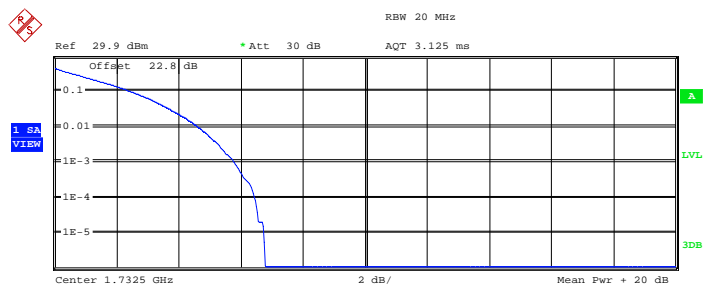

Complementary Cumulative Distribution Function
 NOF samples: 100000, Usable BW: 23.7MHz

Trace 1	
Mean	21.60 dBm
Peak	28.37 dBm
Crest	6.77 dB
10 %	2.47 dB
1 %	4.62 dB
.1 %	5.77 dB
.01 %	6.44 dB

Date: 30.JUL.2013 16:18:37

Peak-to-Average Ratio on LTE Band 4 20MHz / 16QAM

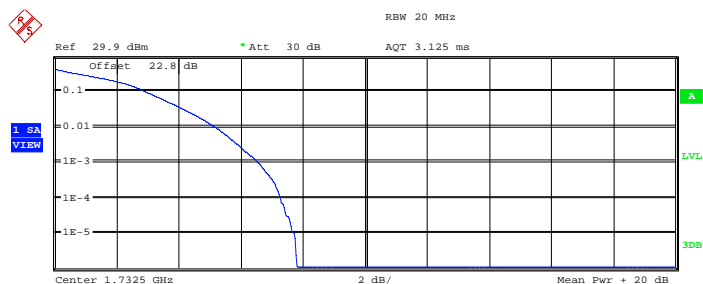

Complementary Cumulative Distribution Function
 NOF samples: 100000, Usable BW: 23.7MHz

Trace 1	
Mean	20.86 dBm
Peak	28.66 dBm
Crest	7.79 dB
10 %	2.92 dB
1 %	5.16 dB
.1 %	6.54 dB
.01 %	7.28 dB

Date: 30.JUL.2013 16:17:43

Peak-to-Average Ratio on LTE Band 13 5MHz / QPSK

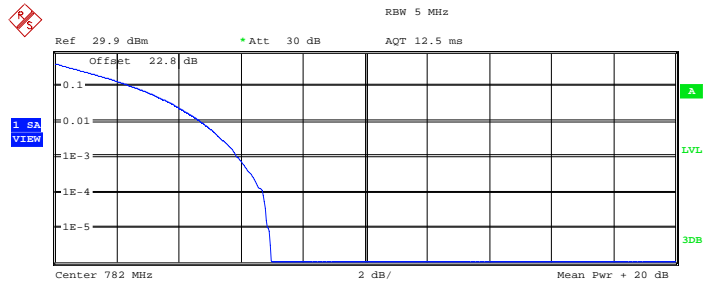

Complementary Cumulative Distribution Function
 NOF samples: 100000, Usable BW: 7.1MHz

Trace 1
 Mean 21.01 dBm
 Peak 27.98 dBm
 Crest 6.97 dB

10 % 2.50 dB
 1 % 4.71 dB
 .1 % 5.87 dB
 .01 % 6.70 dB

Date: 30.JUL.2013 16:11:24

Peak-to-Average Ratio on LTE Band 13 5MHz / 16QAM

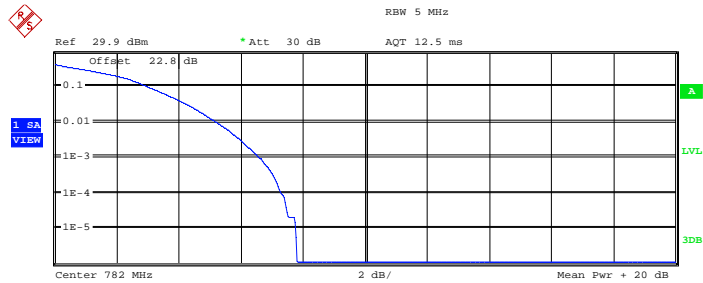

Complementary Cumulative Distribution Function
 NOF samples: 100000, Usable BW: 7.1MHz

Trace 1
 Mean 19.90 dBm
 Peak 27.69 dBm
 Crest 7.79 dB

10 % 3.01 dB
 1 % 5.19 dB
 .1 % 6.57 dB
 .01 % 7.28 dB

Date: 30.JUL.2013 16:11:11

Peak-to-Average Ratio on LTE Band 13 10MHz / QPSK

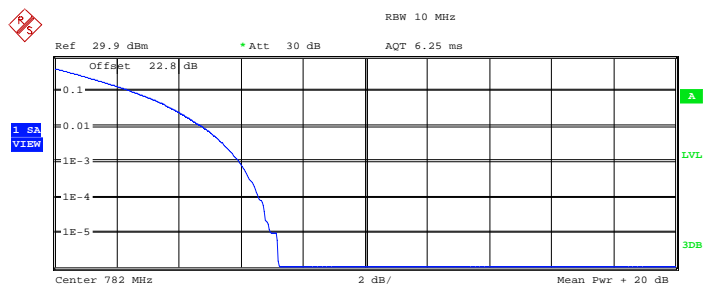

Complementary Cumulative Distribution Function
 NOF samples: 100000, Usable BW: 11.2MHz

Trace 1	
Mean	20.94 dBm
Peak	28.15 dBm
Crest	7.21 dB
10 %	2.50 dB
1 %	4.78 dB
.1 %	5.93 dB
.01 %	6.57 dB

Date: 30.JUL.2013 16:10:26

Peak-to-Average Ratio on LTE Band 13 10MHz / 16QAM

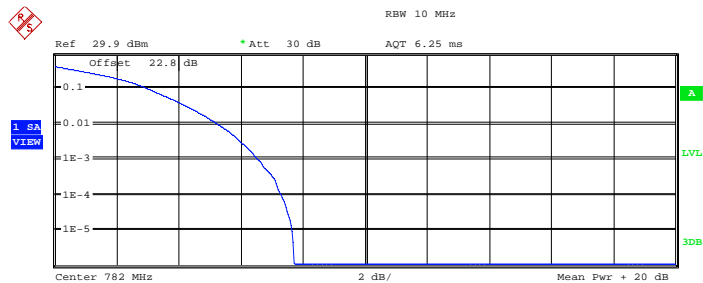

Complementary Cumulative Distribution Function
 NOF samples: 100000, Usable BW: 11.2MHz

Trace 1	
Mean	20.02 dBm
Peak	27.73 dBm
Crest	7.71 dB
10 %	3.01 dB
1 %	5.26 dB
.1 %	6.54 dB
.01 %	7.31 dB

Date: 30.JUL.2013 16:10:51

3.3 Occupied Bandwidth

3.3.1 Description of Occupied Bandwidth Measurement

The occupied bandwidth is the width of a frequency band such that, below the lower and above the upper frequency limits, the mean powers emitted are each equal to a specified percentage 0.5% of the total mean transmitted power.

The 26dB occupied bandwidth is the width of a frequency band such that, below the lower and above the upper frequency limits, the mean powers emitted are each equal 26 dB.

The 26 dB emission bandwidth is defined as the frequency range between two points, one above and one below the carrier frequency, at which the spectral density of the emission is attenuated 26 dB below the maximum in-band spectral density of the modulated signal. Spectral density (power per unit bandwidth) is to be measured with a detector of resolution bandwidth equal to approximately 1.0% of the emission bandwidth.

3.3.2 Measuring Instruments

Measuring equipment is listed in the section 4 of this test report.

3.3.3 Test Procedures

1. The EUT was connected to Spectrum Analyzer and Base Station via power divider.
2. The 26dB and 99% occupied bandwidth (BW) of the middle channel for the highest RF powers with full RB sizes were measured.

3.3.4 Test Setup

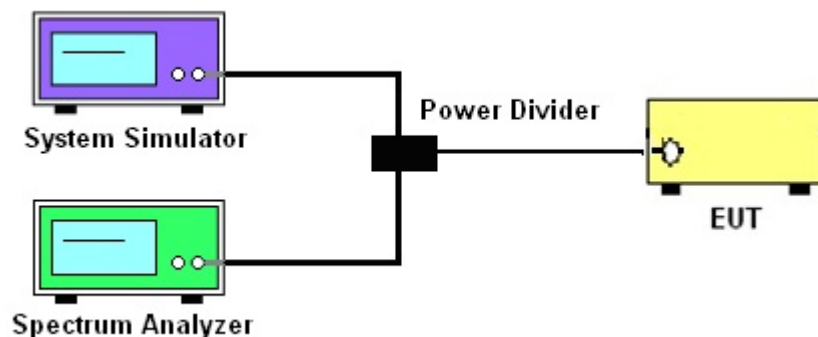

3.3.5 Test Result (Plots) of Occupied Bandwidth

Band :	LTE Band 4	BW / Mod. :	1.4MHz / QPSK
--------	------------	-------------	---------------

99% Occupied Bandwidth Plot on Channel 20175

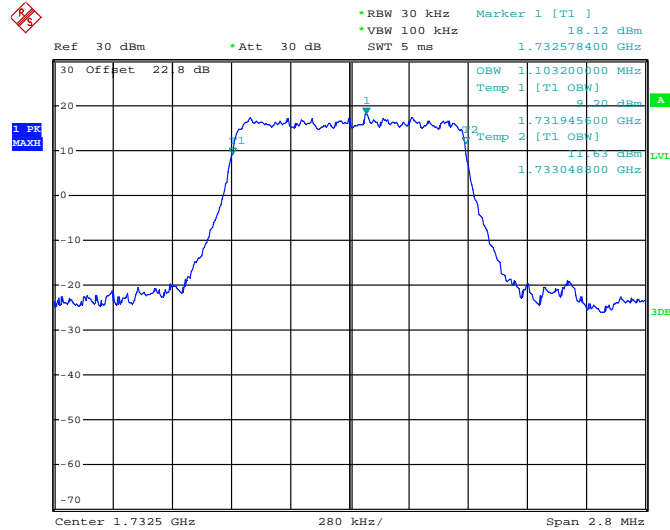

Date: 29.JUL.2013 16:58:45

26dB Bandwidth Plot on Channel 20175

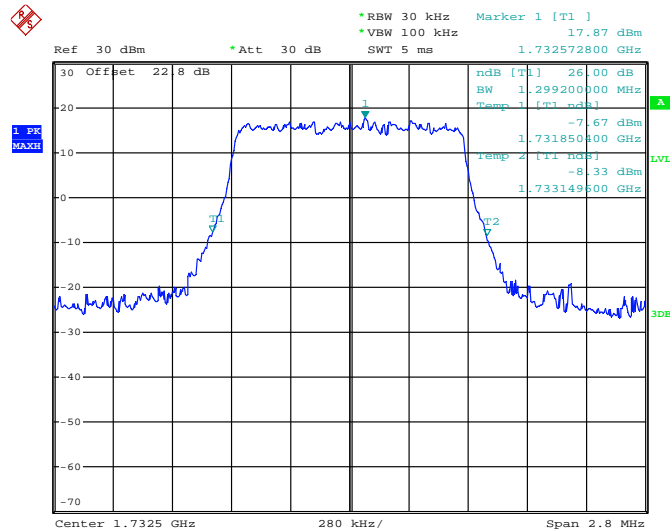

Date: 29.JUL.2013 17:14:39

Band :	LTE Band 4	BW / Mod. :	1.4MHz / 16QAM
---------------	------------	--------------------	----------------

99% Occupied Bandwidth Plot on Channel 20175

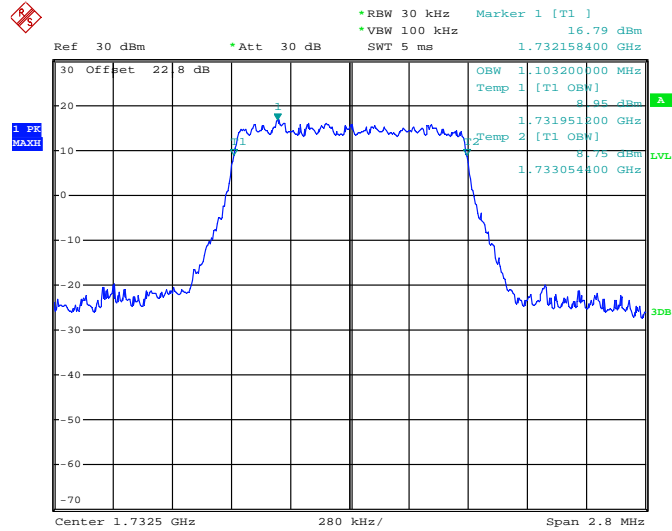

Date: 29.JUL.2013 16:59:01

26dB Bandwidth Plot on Channel 20175

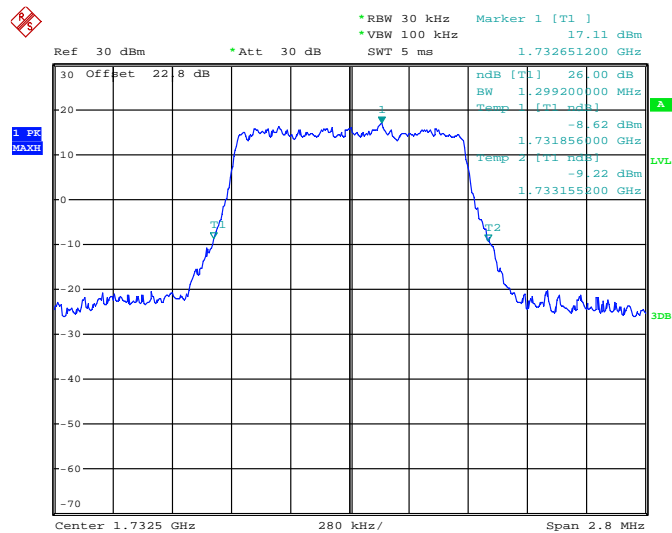

Date: 29.JUL.2013 17:14:19

Band :	LTE Band 4	BW / Mod. :	3MHz / QPSK
---------------	------------	--------------------	-------------

99% Occupied Bandwidth Plot on Channel 20175

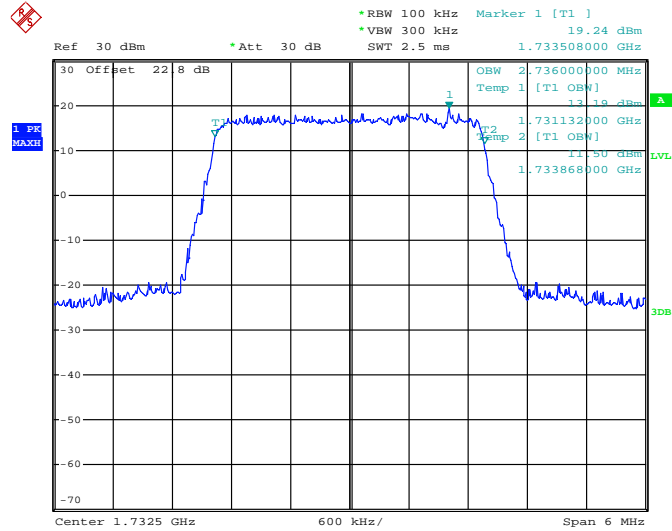

Date: 29.JUL.2013 17:00:27

26dB Bandwidth Plot on Channel 20175

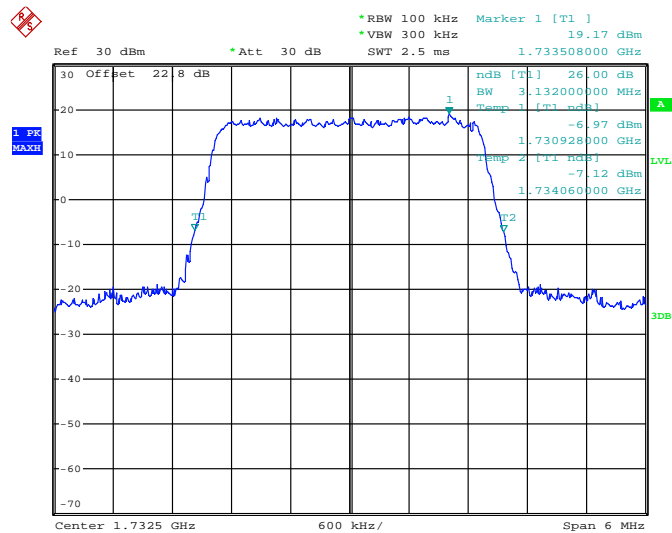

Date: 29.JUL.2013 17:11:53

Band :	LTE Band 4	BW / Mod. :	3MHz / 16QAM
---------------	------------	--------------------	--------------

99% Occupied Bandwidth Plot on Channel 20175

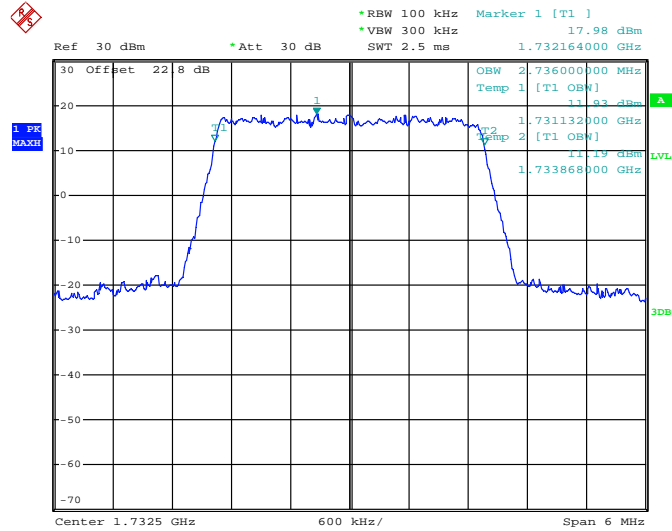

Date: 29.JUL.2013 17:00:02

26dB Bandwidth Plot on Channel 20175

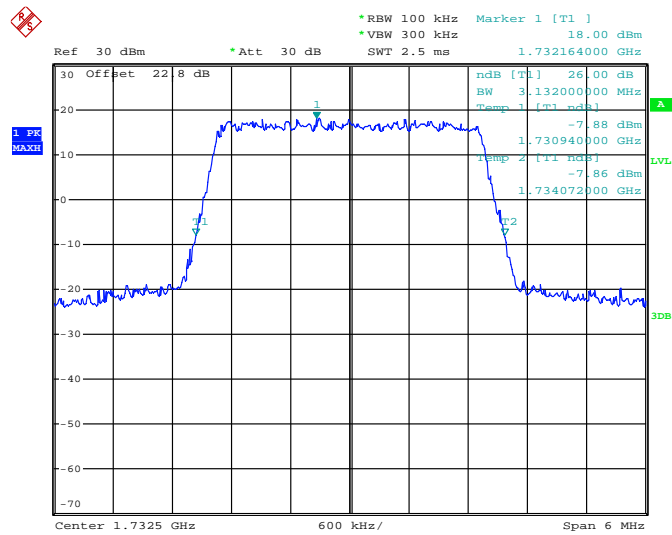

Date: 29.JUL.2013 17:12:17

Band :	LTE Band 4	BW / Mod. :	5MHz / QPSK
---------------	------------	--------------------	-------------

99% Occupied Bandwidth Plot on Channel 20175

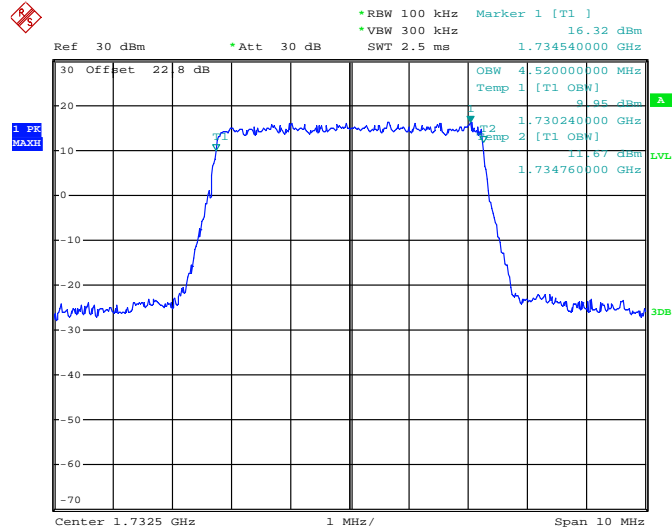

Date: 29.JUL.2013 17:01:08

26dB Bandwidth Plot on Channel 20175

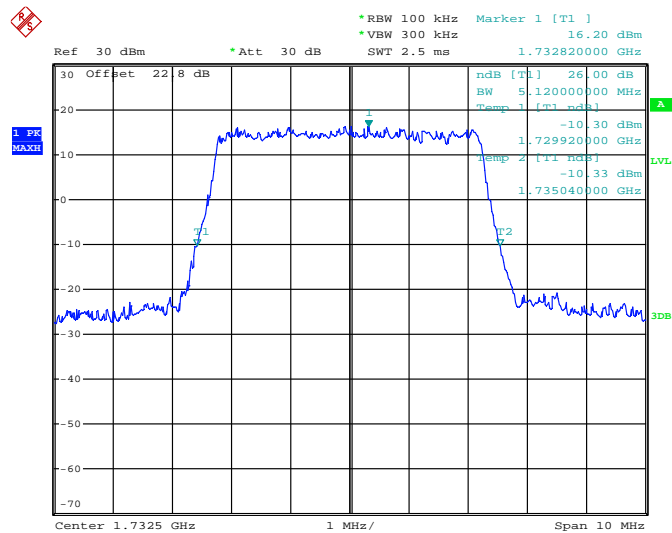

Date: 29.JUL.2013 17:11:06

Band :	LTE Band 4	BW / Mod. :	5MHz / 16QAM
---------------	------------	--------------------	--------------

99% Occupied Bandwidth Plot on Channel 20175

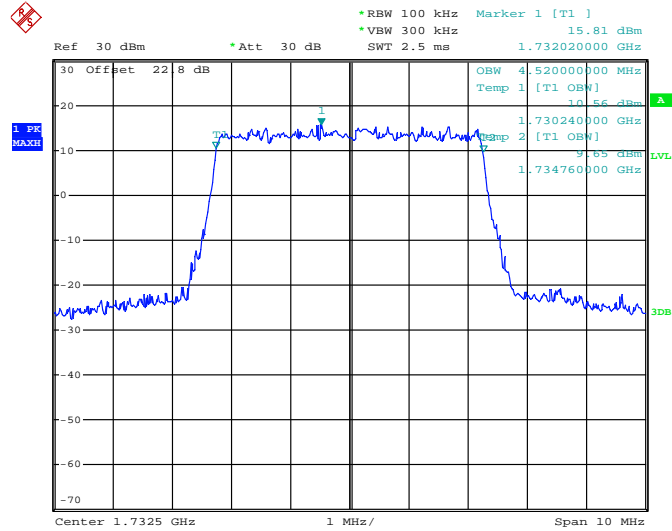

Date: 29.JUL.2013 17:01:29

26dB Bandwidth Plot on Channel 20175

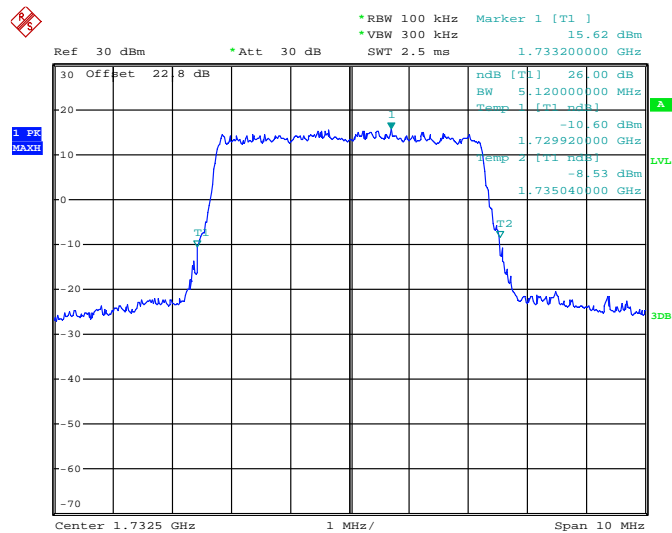

Date: 29.JUL.2013 17:10:47

Band :	LTE Band 4	BW / Mod. :	10MHz / QPSK
---------------	------------	--------------------	--------------

99% Occupied Bandwidth Plot on Channel 20175

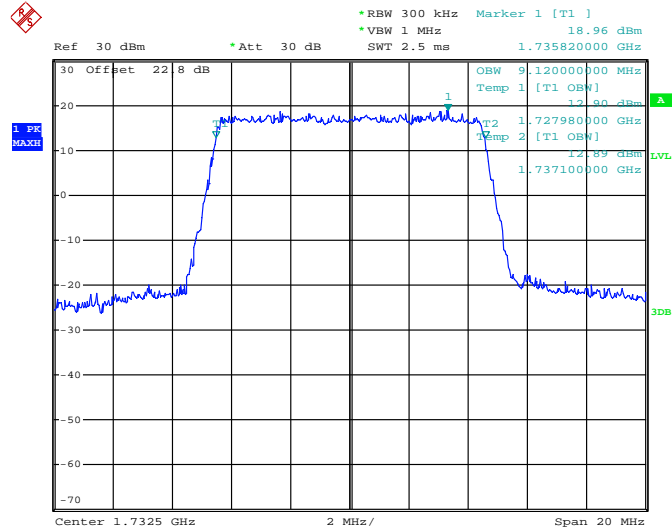

Date: 29.JUL.2013 17:02:37

26dB Bandwidth Plot on Channel 20175

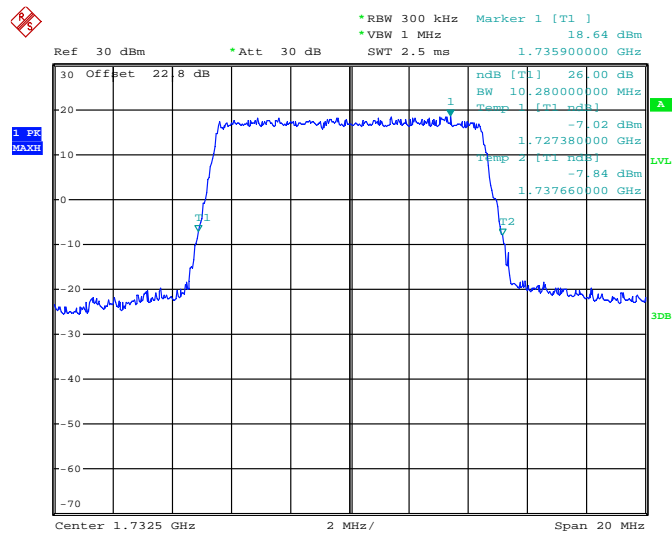

Date: 29.JUL.2013 17:08:49

Band :	LTE Band 4	BW / Mod. :	10MHz / 16QAM
---------------	------------	--------------------	---------------

99% Occupied Bandwidth Plot on Channel 20175

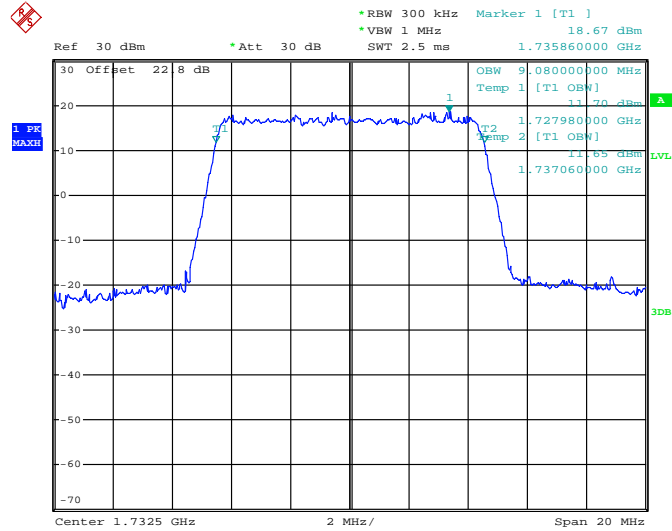

Date: 29.JUL.2013 17:02:19

26dB Bandwidth Plot on Channel 20175

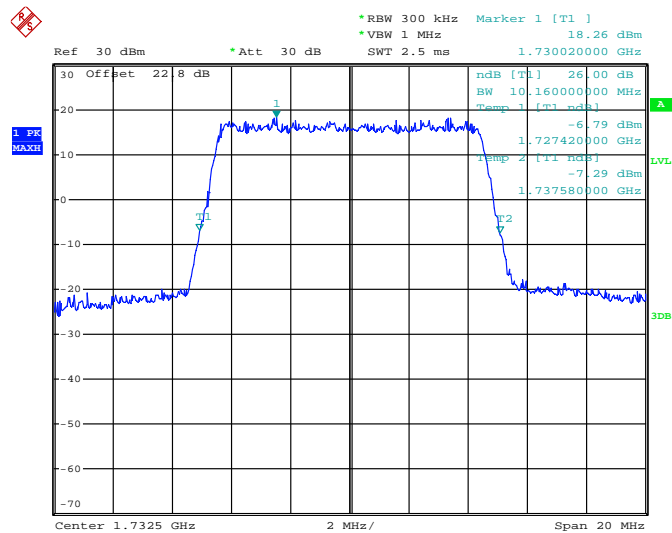

Date: 29.JUL.2013 17:09:07

Band :	LTE Band 4	BW / Mod. :	15MHz / QPSK
---------------	------------	--------------------	--------------

99% Occupied Bandwidth Plot on Channel 20175

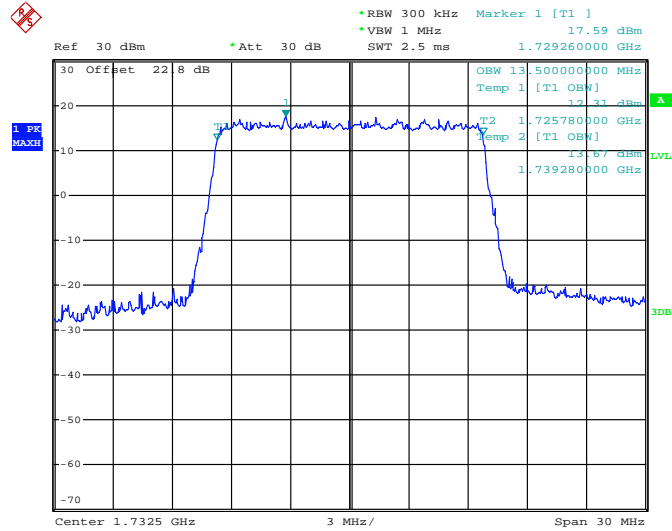

Date: 29.JUL.2013 17:03:05

26dB Bandwidth Plot on Channel 20175

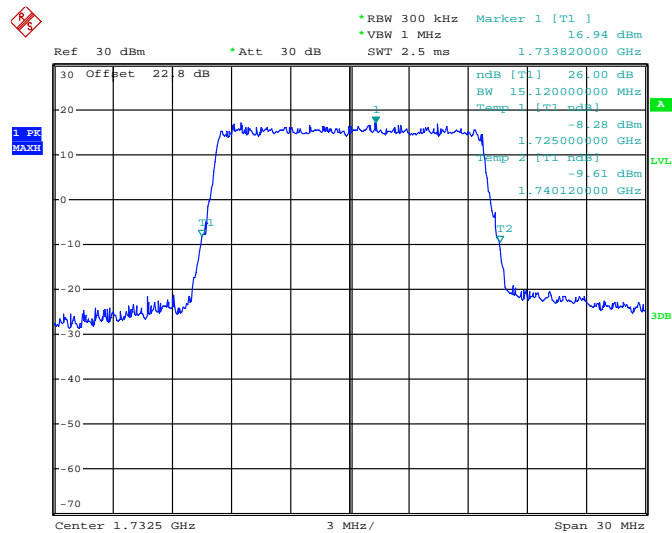

Date: 29.JUL.2013 17:07:21

Band :	LTE Band 4	BW / Mod. :	15MHz / 16QAM
---------------	------------	--------------------	---------------

99% Occupied Bandwidth Plot on Channel 20175

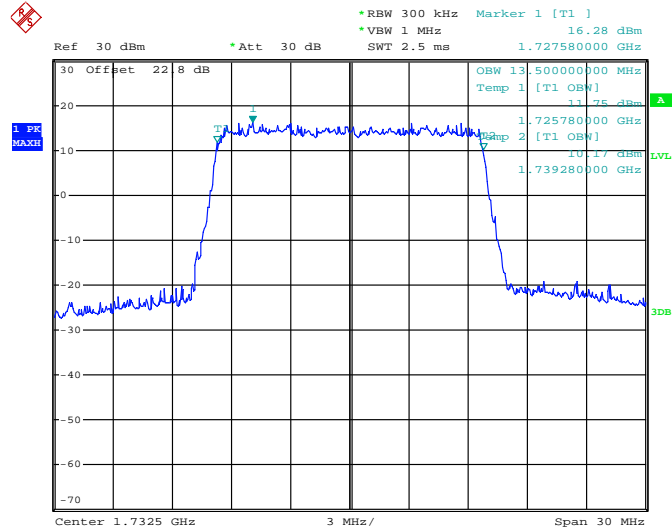

Date: 29.JUL.2013 17:03:23

26dB Bandwidth Plot on Channel 20175

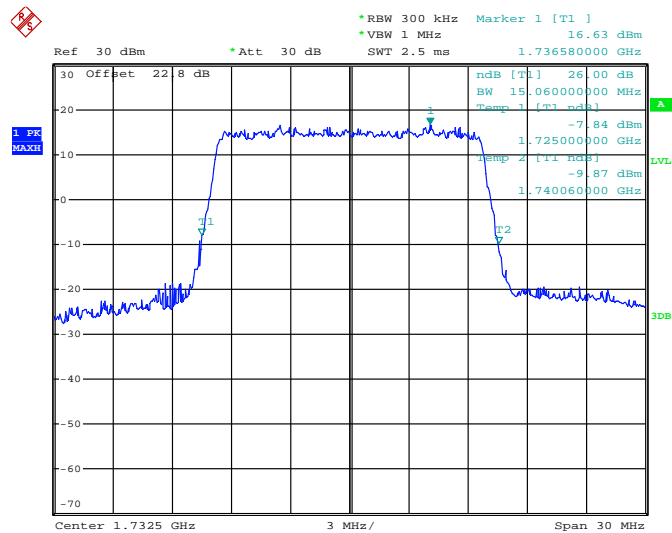

Date: 29.JUL.2013 17:07:04

Band :	LTE Band 4	BW / Mod. :	20MHz / QPSK
---------------	------------	--------------------	--------------

99% Occupied Bandwidth Plot on Channel 20175

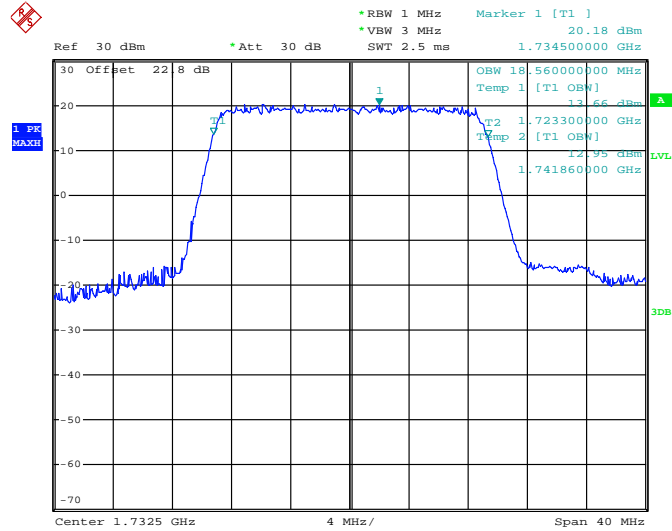

Date: 29.JUL.2013 17:04:30

26dB Bandwidth Plot on Channel 20175

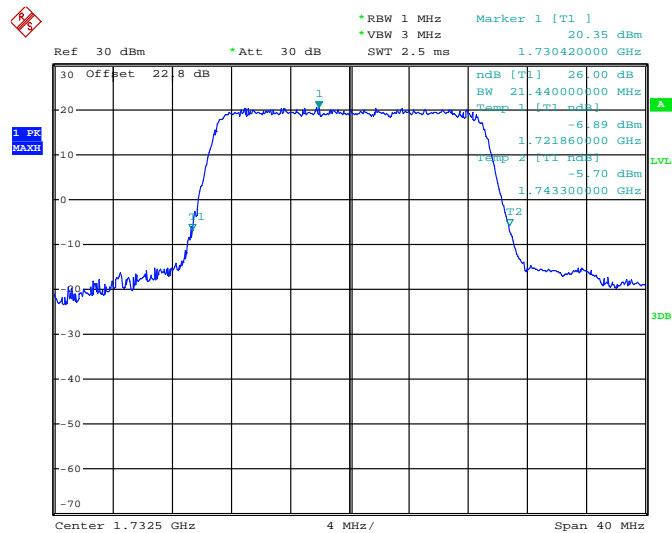

Date: 29.JUL.2013 17:05:22

Band :	LTE Band 4	BW / Mod. :	20MHz / 16QAM
---------------	------------	--------------------	---------------

99% Occupied Bandwidth Plot on Channel 20175

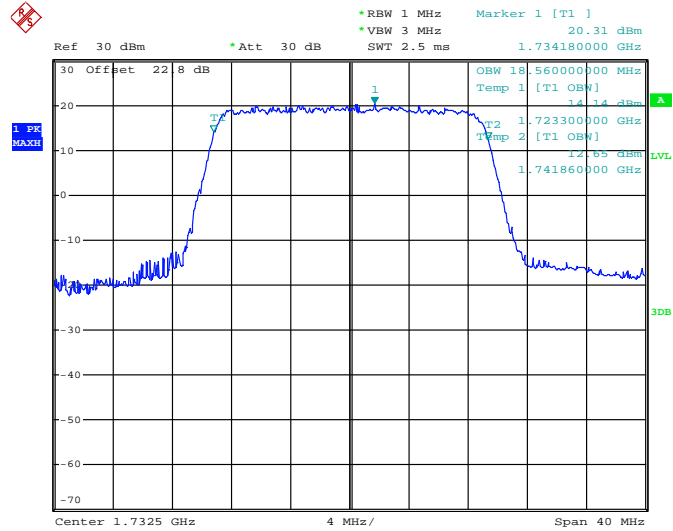

Date: 29.JUL.2013 17:04:13

26dB Bandwidth Plot on Channel 20175

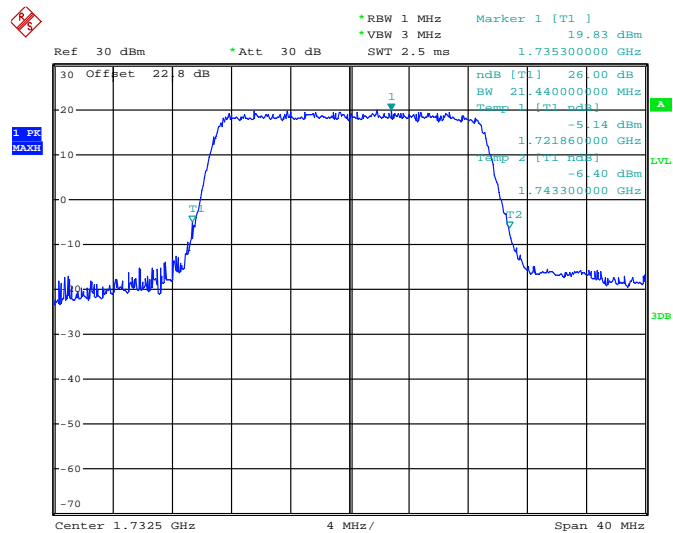

Date: 29.JUL.2013 17:06:04

Band :	LTE Band 13	BW / Mod. :	5MHz / QPSK
---------------	-------------	--------------------	-------------

99% Occupied Bandwidth Plot on Channel 23230

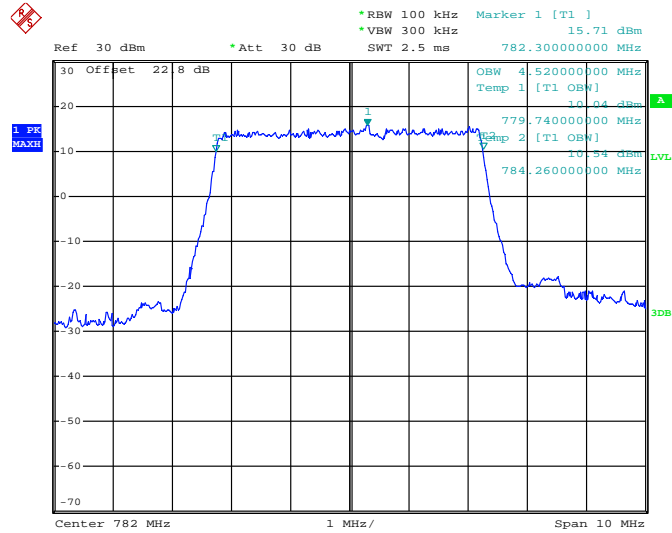

Date: 29.JUL.2013 16:22:02

26dB Bandwidth Plot on Channel 23230

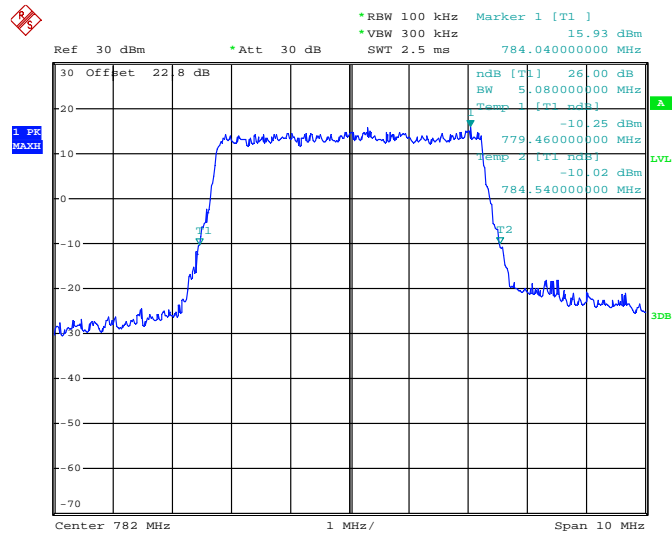

Date: 29.JUL.2013 16:26:03

Band :	LTE Band 13	BW / Mod. :	5MHz / 16QAM
---------------	-------------	--------------------	--------------

99% Occupied Bandwidth Plot on Channel 23230

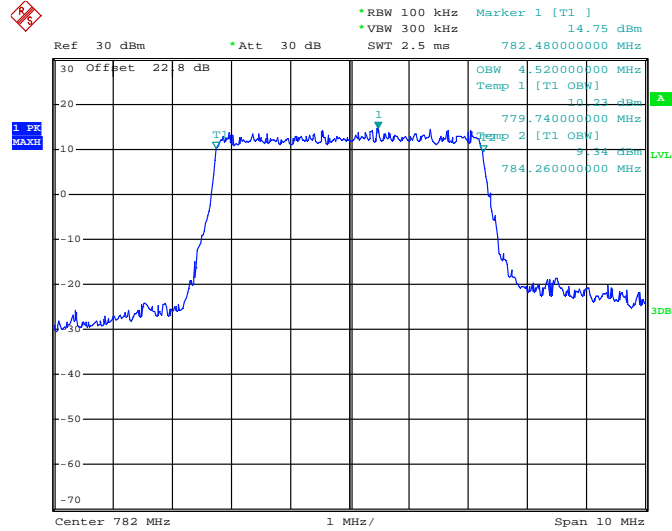

Date: 29.JUL.2013 16:22:21

26dB Bandwidth Plot on Channel 23230

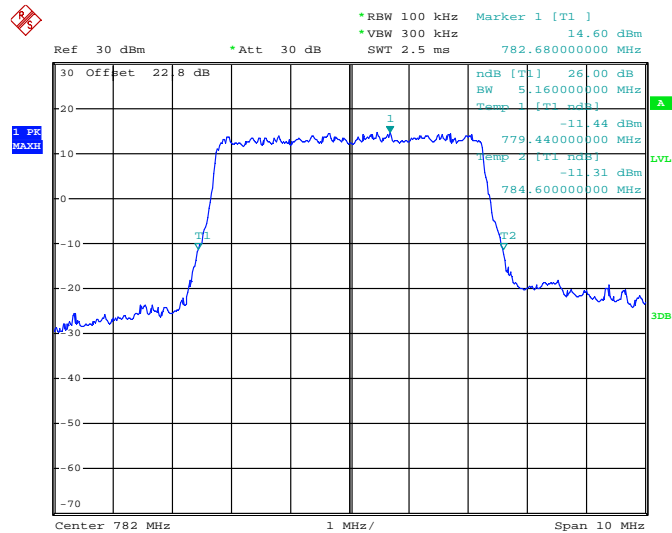

Date: 29.JUL.2013 16:25:47

Band :	LTE Band 13	BW / Mod. :	10MHz / QPSK
---------------	-------------	--------------------	--------------

99% Occupied Bandwidth Plot on Channel 23230

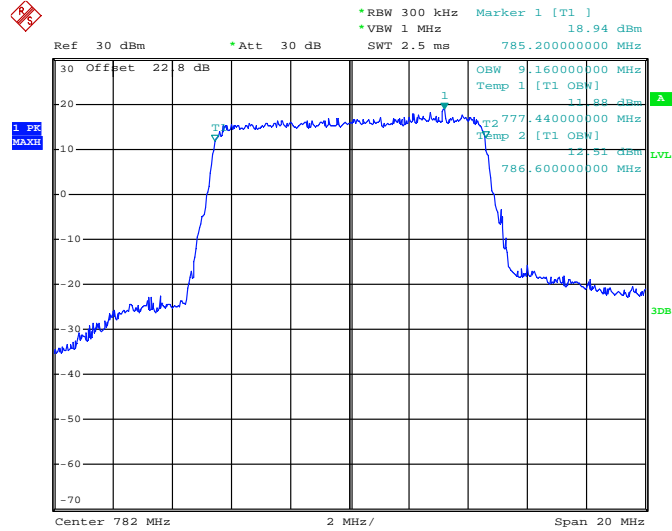

Date: 29.JUL.2013 16:23:46

26dB Bandwidth Plot on Channel 23230

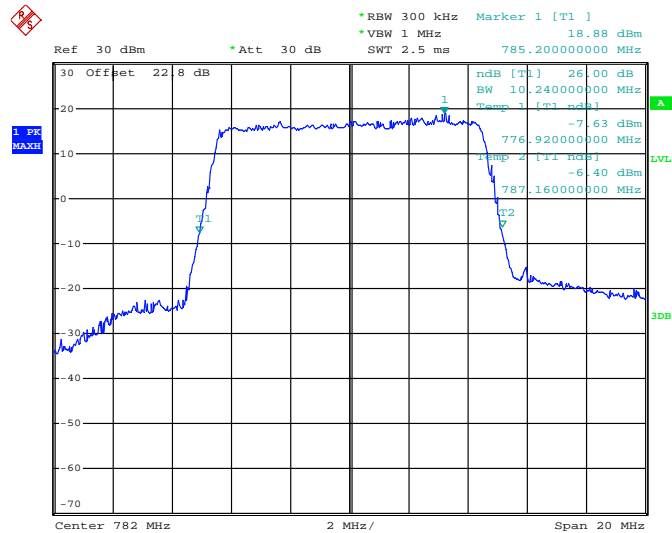

Date: 29.JUL.2013 16:24:17

Band :	LTE Band 13	BW / Mod. :	10MHz / 16QAM
---------------	-------------	--------------------	---------------

99% Occupied Bandwidth Plot on Channel 23230

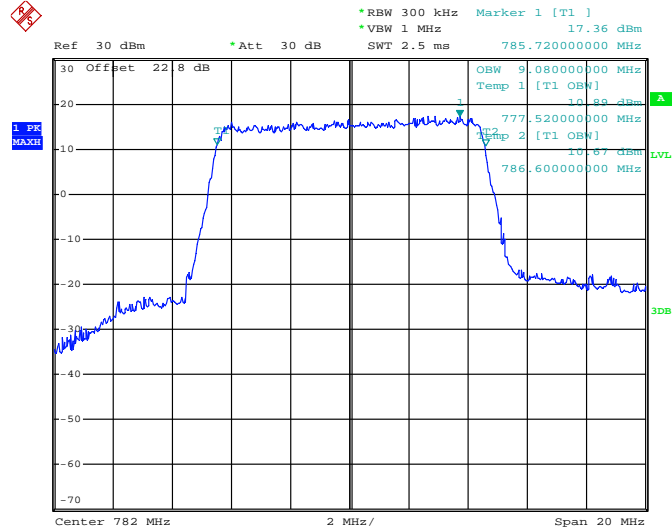

Date: 29.JUL.2013 16:23:28

26dB Bandwidth Plot on Channel 23230

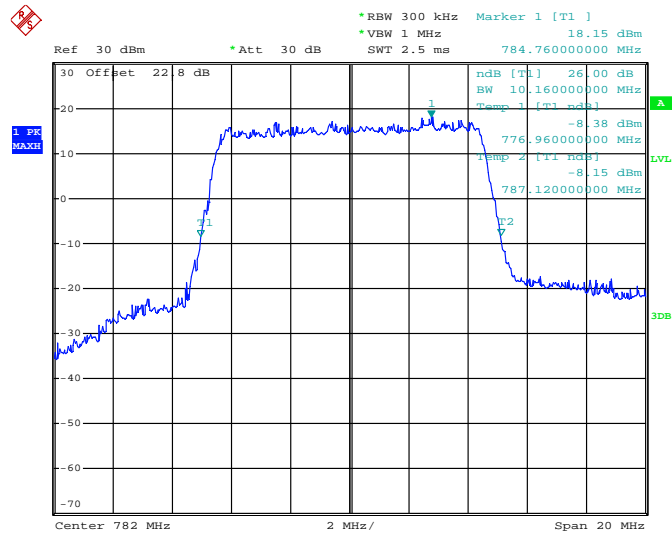

Date: 29.JUL.2013 16:24:37

3.4 Conducted Band Edge Measurement

3.4.1 Description of Conducted Band Edge Measurement

27.53 (c)

For operations in the 776-788 MHz band, the FCC limit is $43 + 10\log_{10}(P[\text{Watts}])$ dB below the transmitter power $P(\text{Watts})$ in a 100 kHz bandwidth. However, in the 100 kHz bands immediately outside and adjacent to the frequency block, a resolution bandwidth of at least 30 kHz may be employed.

27.53 (h)

For operations in the 1710 – 1755 MHz band, the FCC limit is $43 + 10\log_{10}(P[\text{Watts}])$ dB below the transmitter power $P(\text{Watts})$ in a 1 MHz bandwidth. However, in the 1MHz bands immediately outside and adjacent to the licensee's frequency block, a resolution bandwidth of at least one percent of the emission bandwidth of the fundamental emission of the transmitter may be employed.

3.4.2 Measuring Instruments

Measuring equipment is listed in the section 4 of this test report.

3.4.3 Test Procedures

1. The EUT was connected to Spectrum Analyzer and Base Station via power divider.
2. The band edges of low and high channels for the highest RF powers were measured. Setting $RBW \geq 1\%$ EBW, and measuring bandwidth = 1MHz.
3. The RF fundamental frequency should be excluded against the limit line in the operating frequency band.
4. The limit line is derived from $43 + 10\log(P)$ dB below the transmitter power P(Watts)
= $P(W) - [43 + 10\log(P)]$ (dB)
= $[30 + 10\log(P)]$ (dBm) - $[43 + 10\log(P)]$ (dB)
= -13dBm.

3.4.4 Test Setup

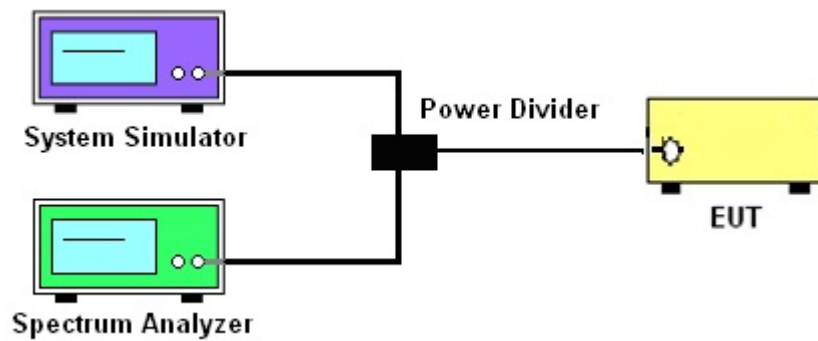

3.4.5 Test Result (Plots) of Conducted Band Edge

Band :	LTE Band 4	Band Width :	1.4MHz / QPSK
---------------	------------	---------------------	---------------

Lower Band Edge Plot for QPSK-RB Size 1, RB Offset 0

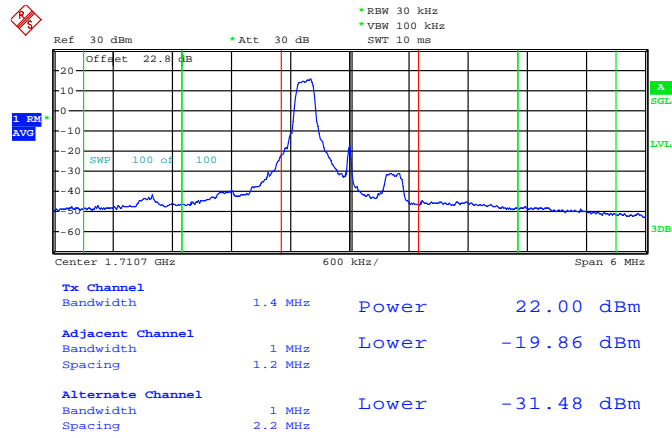

Date: 29.JUL.2013 17:23:52

Lower Band Edge Plot for QPSK-RB Size 6, RB Offset 0

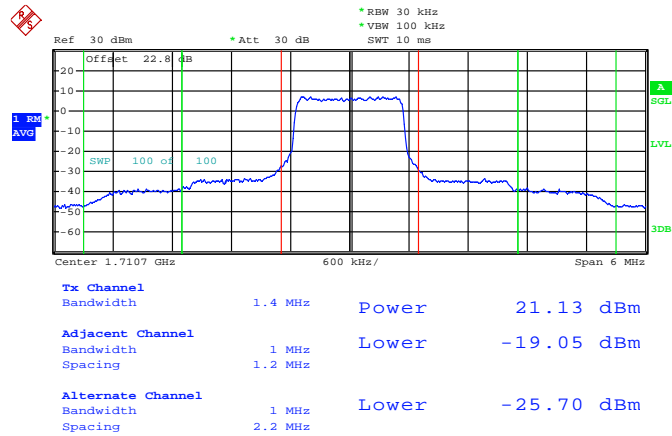

Date: 29.JUL.2013 17:24:38

Higher Band Edge Plot for QPSK-RB Size 1, RB Offset 5

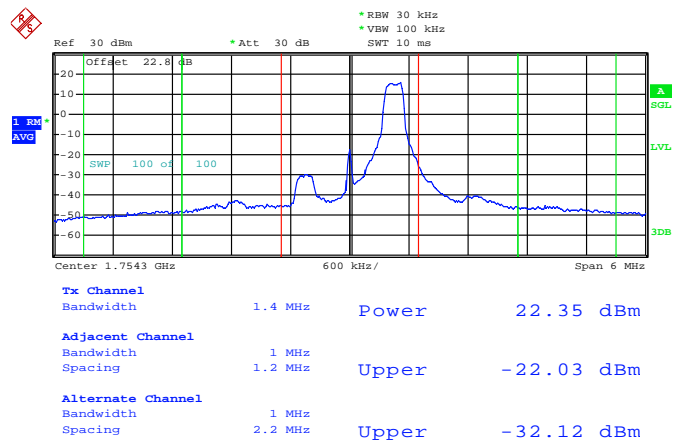

Date: 29.JUL.2013 17:23:05

Higher Band Edge Plot for QPSK-RB Size 6, RB Offset 0

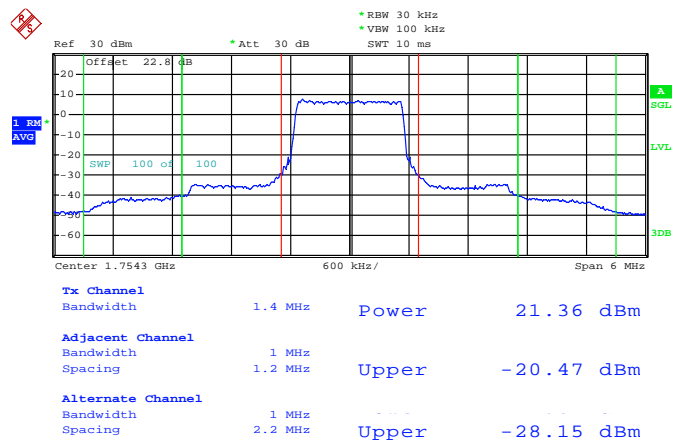

Date: 29.JUL.2013 17:22:11

Band :	LTE Band 4	Band Width :	1.4MHz / 16QAM
---------------	------------	---------------------	----------------

Lower Band Edge Plot for 16QAM -RB Size 1, RB Offset 0

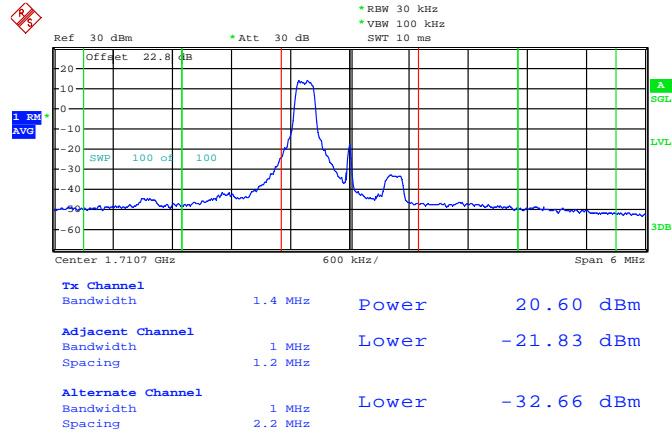

Date: 29.JUL.2013 17:24:07

Lower Band Edge Plot for 16QAM-RB Size 6, RB Offset 0

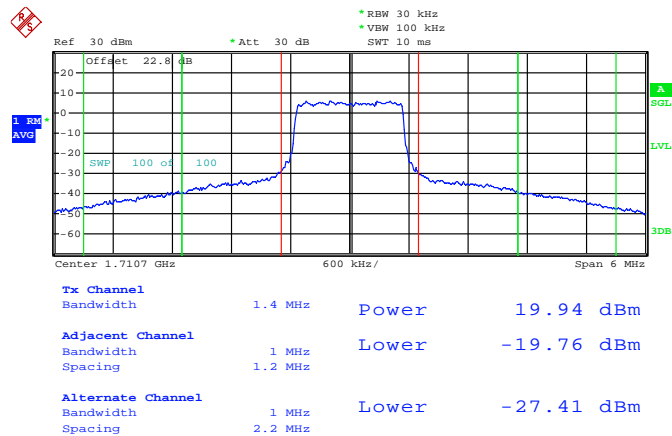

Date: 29.JUL.2013 17:24:22

Higher Band Edge Plot for 16QAM-RB Size 1, RB Offset 5

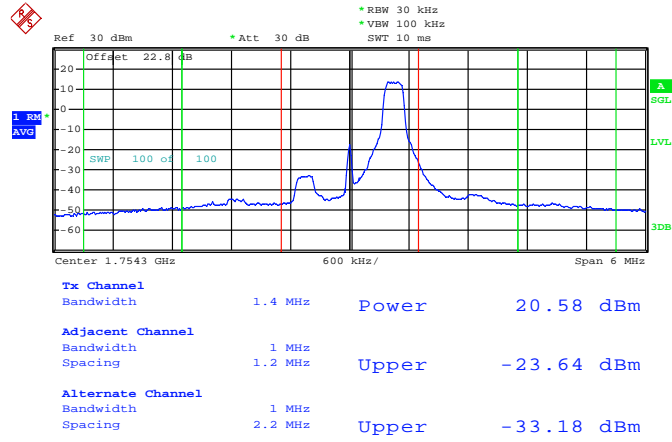

Date: 29.JUL.2013 17:22:48

Higher Band Edge Plot for 16QAM-RB Size 6, RB Offset 0

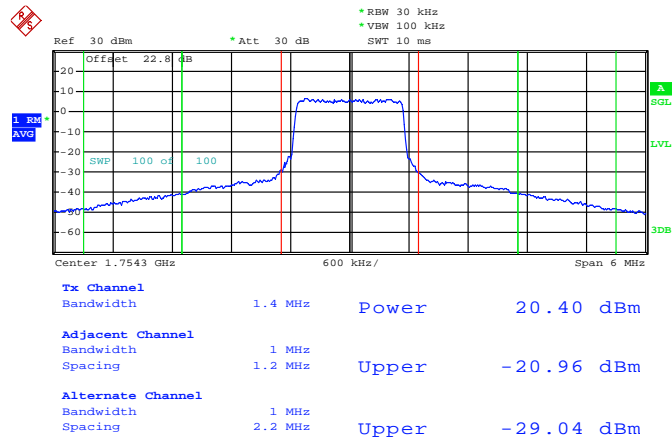

Date: 29.JUL.2013 17:22:28

Band :	LTE Band 4	Band Width :	3MHz / QPSK
---------------	------------	---------------------	-------------

Lower Band Edge Plot for QPSK-RB Size 1, RB Offset 0

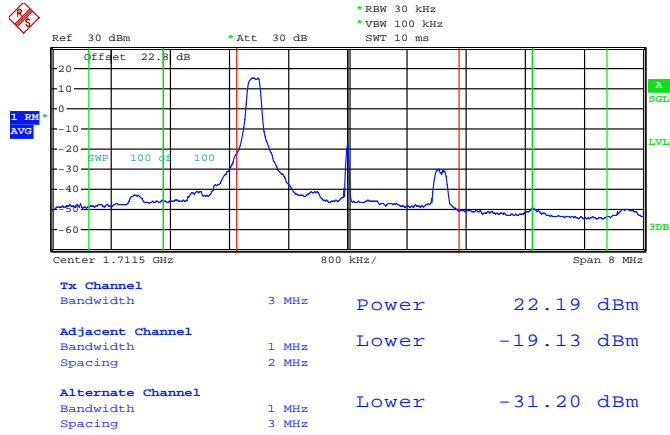

Date: 29.JUL.2013 17:26:56

Lower Band Edge Plot for QPSK-RB Size 15, RB Offset 0

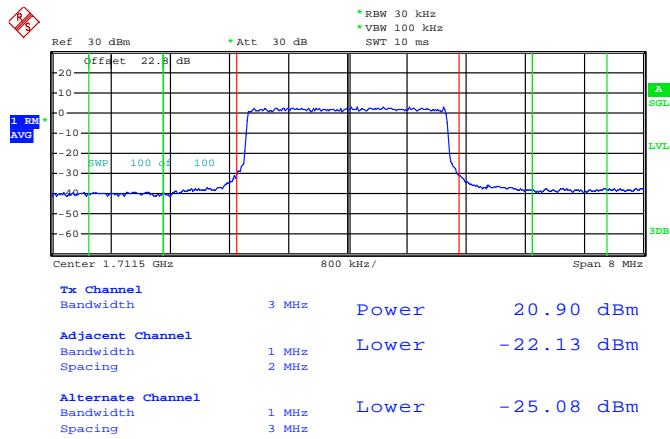

Date: 29.JUL.2013 17:25:42

Higher Band Edge Plot for QPSK-RB Size 1, RB Offset 14

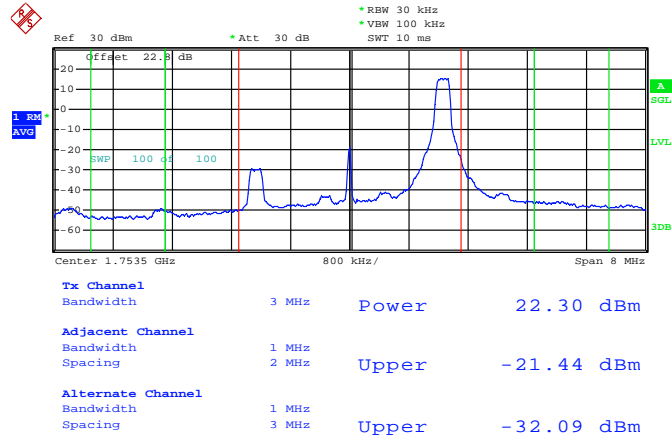

Date: 29.JUL.2013 17:29:12

Higher Band Edge Plot for QPSK-RB Size 15, RB Offset 0

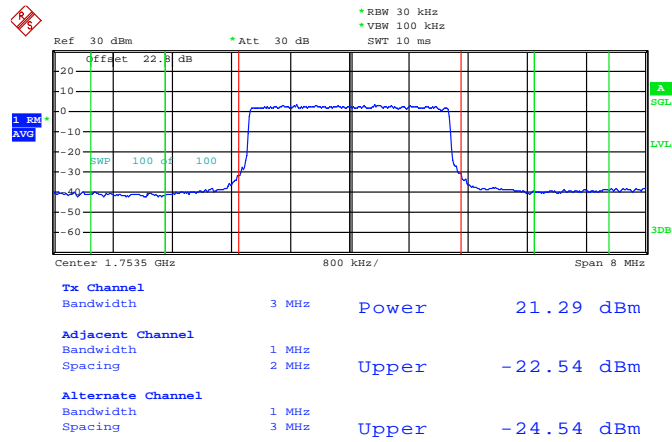

Date: 29.JUL.2013 17:30:06

Band :	LTE Band 4	Band Width :	3MHz / 16QAM
---------------	------------	---------------------	--------------

Lower Band Edge Plot for 16QAM-RB Size 1, RB Offset 0

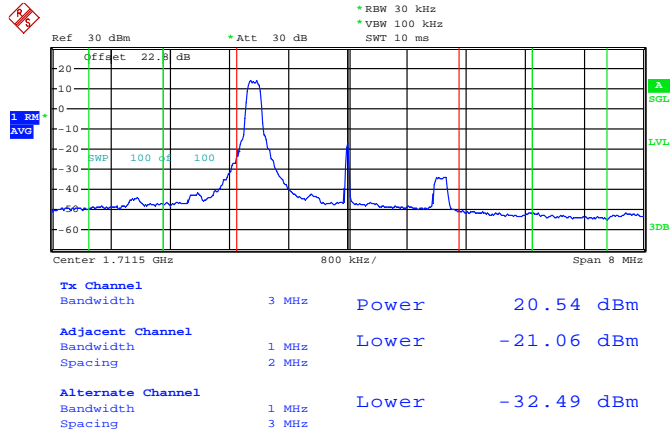

Date: 29.JUL.2013 17:26:34

Lower Band Edge Plot for 16QAM-RB Size 15, RB Offset 0

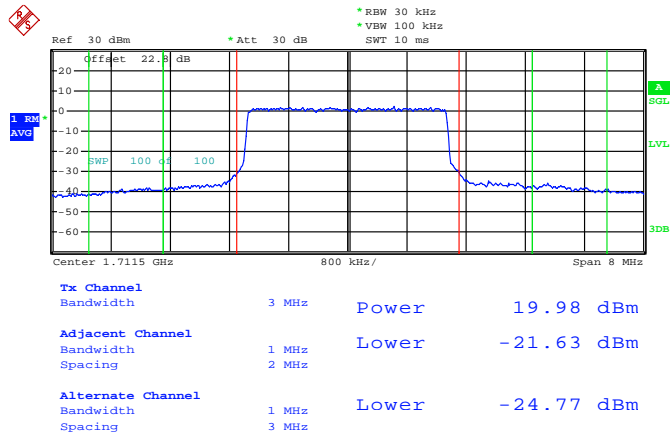

Date: 29.JUL.2013 17:26:17

Higher Band Edge Plot for 16QAM-RB Size 1, RB Offset 14

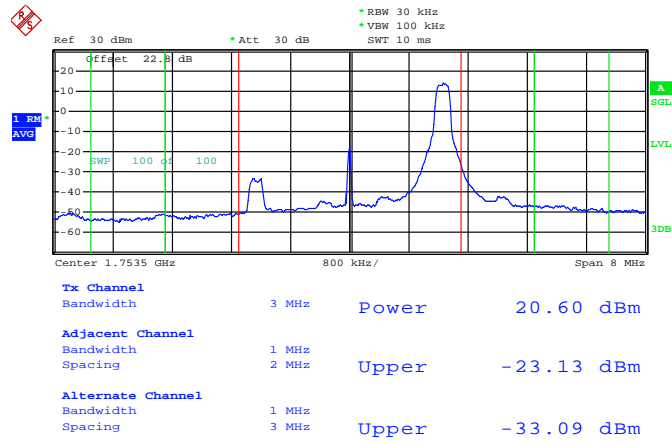

Date: 29.JUL.2013 17:29:29

Higher Band Edge Plot for 16QAM-RB Size 15, RB Offset 0

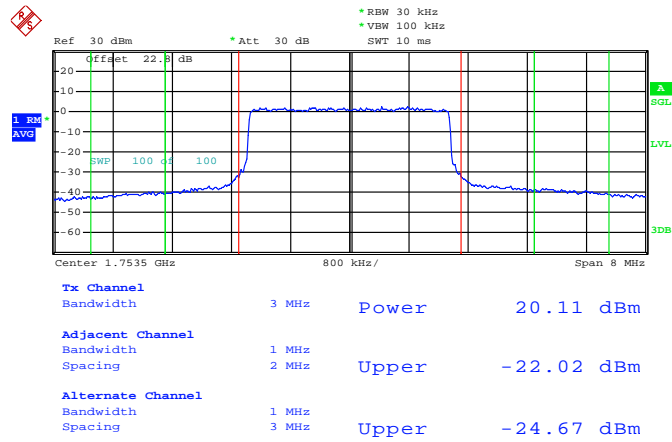

Date: 29.JUL.2013 17:29:49

Band :	LTE Band 4	Band Width :	5MHz / QPSK
---------------	------------	---------------------	-------------

Lower Band Edge Plot for QPSK-RB Size 1, RB Offset 0

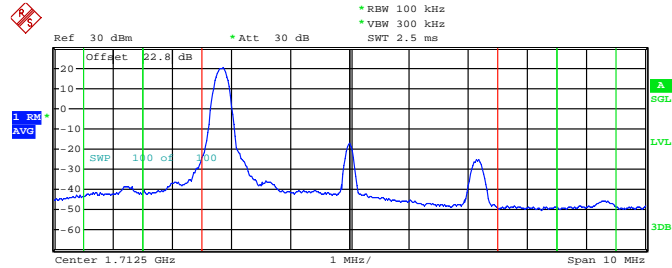

Tx Channel	Bandwidth	5 MHz	Power	22.24 dBm
Adjacent Channel	Bandwidth	1 MHz	Lower	-25.18 dBm
	Spacing	3 MHz		
Alternate Channel	Bandwidth	1 MHz	Lower	-31.55 dBm
	Spacing	4 MHz		

Date: 29.JUL.2013 17:33:37

Lower Band Edge Plot for QPSK-RB Size 25, RB Offset 0

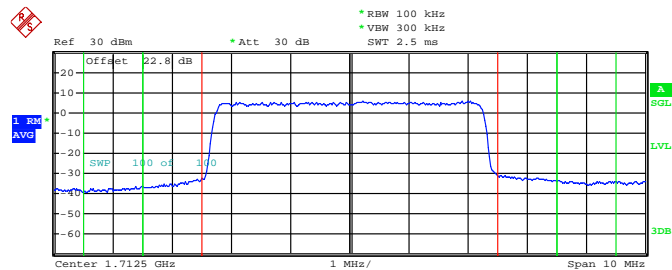

Tx Channel	Bandwidth	5 MHz	Power	20.77 dBm
Adjacent Channel	Bandwidth	1 MHz	Lower	-25.58 dBm
	Spacing	3 MHz		
Alternate Channel	Bandwidth	1 MHz	Lower	-28.18 dBm
	Spacing	4 MHz		

Date: 29.JUL.2013 17:35:33

Higher Band Edge Plot for QPSK-RB Size 1, RB Offset 24

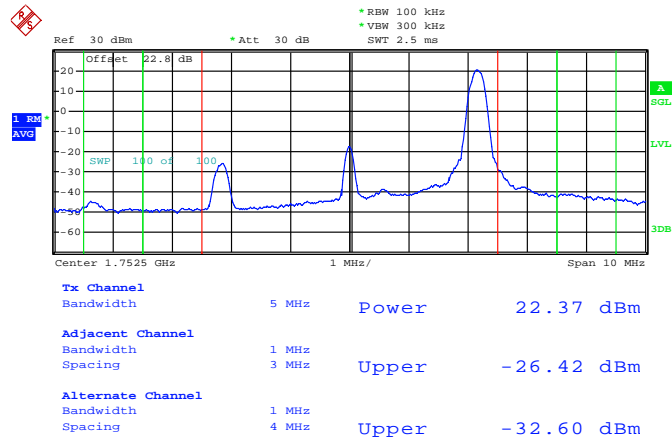

Date: 29.JUL.2013 17:32:52

Higher Band Edge Plot for QPSK-RB Size 25, RB Offset 0

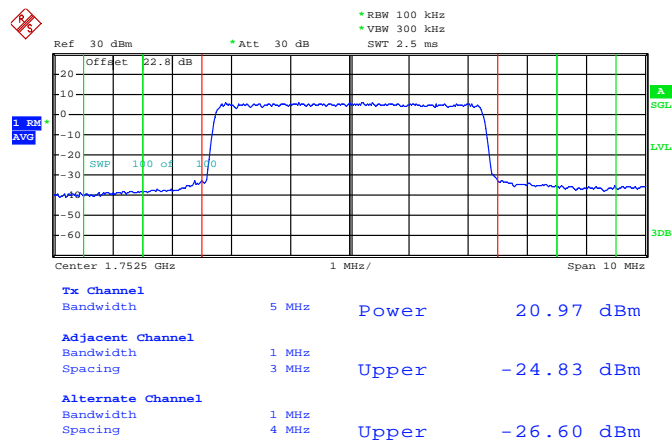

Date: 29.JUL.2013 17:31:54

Band :	LTE Band 4	Band Width :	5MHz / 16QAM
---------------	------------	---------------------	--------------

Lower Band Edge Plot for 16QAM-RB Size 1, RB Offset 0

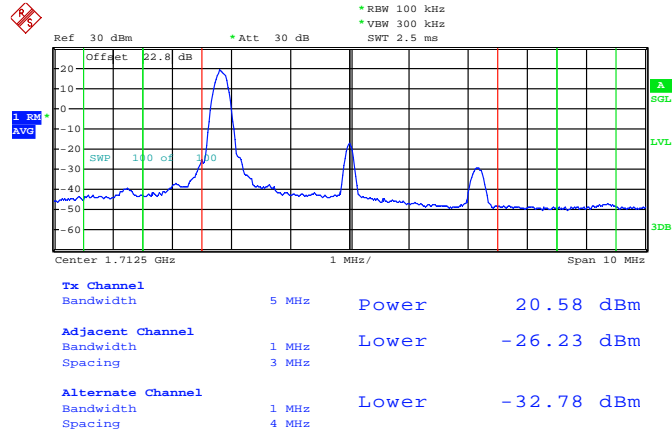

Date: 29.JUL.2013 17:33:57

Lower Band Edge Plot for 16QAM-RB Size 25, RB Offset 0

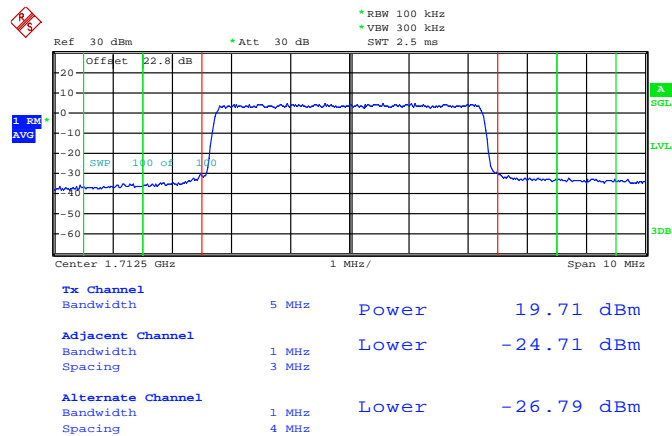

Date: 29.JUL.2013 17:35:04

Higher Band Edge Plot for 16QAM-RB Size 1, RB Offset 24

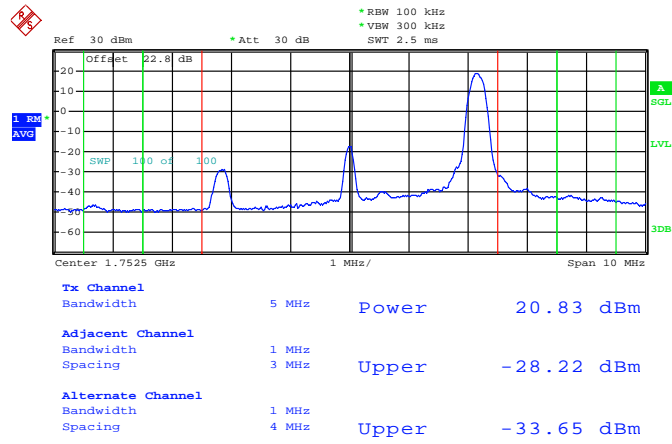

Date: 29.JUL.2013 17:32:35

Higher Band Edge Plot for 16QAM-RB Size 25, RB Offset 0

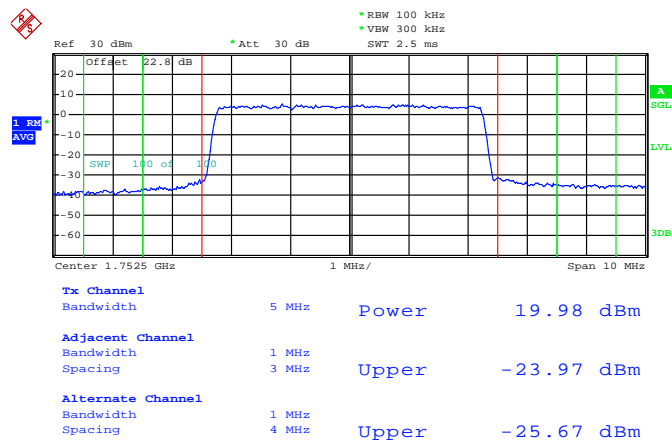

Date: 29.JUL.2013 17:32:10

Band :	LTE Band 4	Band Width :	10MHz / QPSK
---------------	------------	---------------------	--------------

Lower Band Edge Plot for QPSK-RB Size 1, RB Offset 0

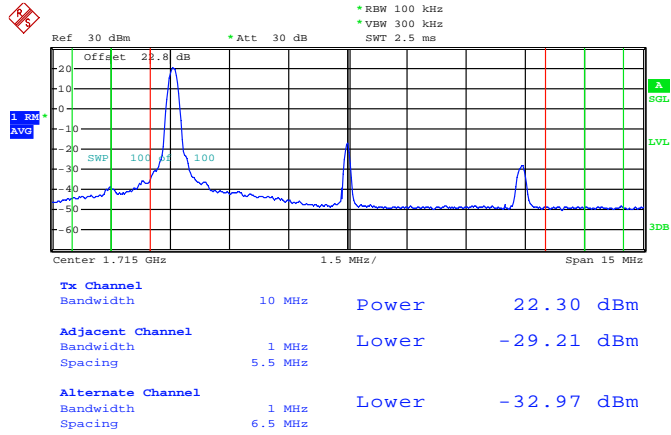

Date: 29.JUL.2013 17:41:47

Lower Band Edge Plot for QPSK-RB Size 50, RB Offset 0

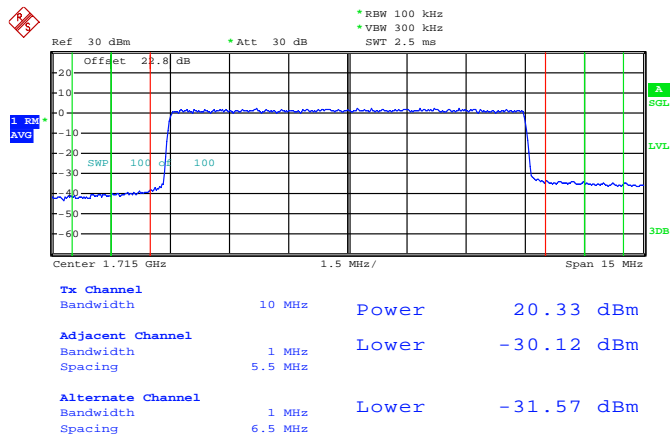

Date: 29.JUL.2013 17:40:52

Higher Band Edge Plot for QPSK-RB Size 1, RB Offset 49

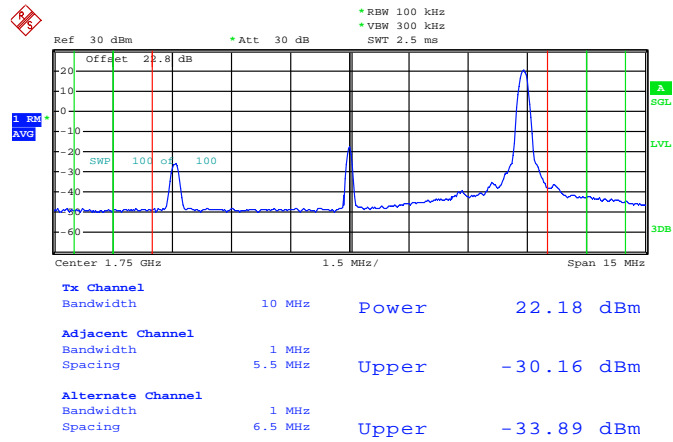

Date: 29.JUL.2013 17:42:53

Higher Band Edge Plot for QPSK-RB Size 50, RB Offset 0

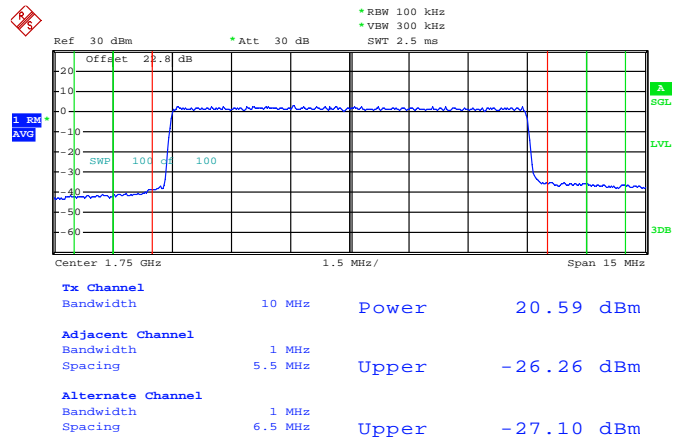

Date: 29.JUL.2013 17:45:35

Band :	LTE Band 4	Band Width :	10MHz / 16QAM
---------------	------------	---------------------	---------------

Lower Band Edge Plot for 16QAM-RB Size 1, RB Offset 0

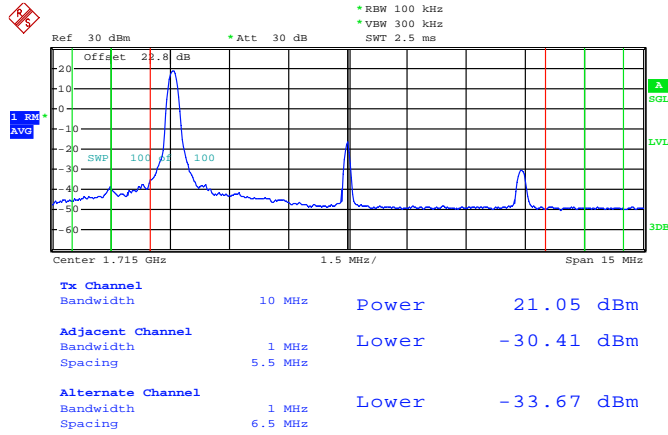

Date: 29.JUL.2013 17:41:29

Lower Band Edge Plot for 16QAM-RB Size 50, RB Offset 0

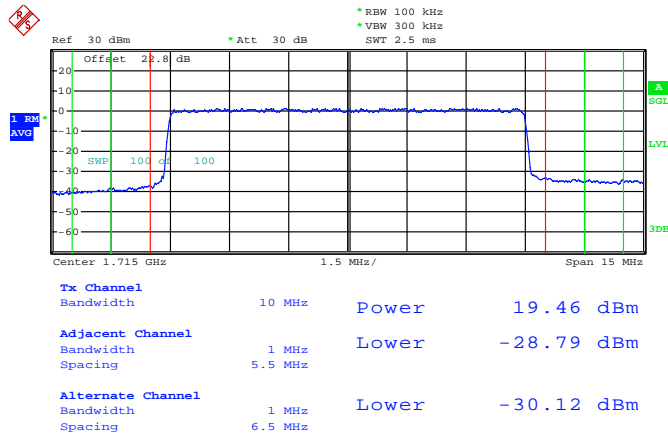

Date: 29.JUL.2013 17:41:09

Higher Band Edge Plot for 16QAM-RB Size 1, RB Offset 49

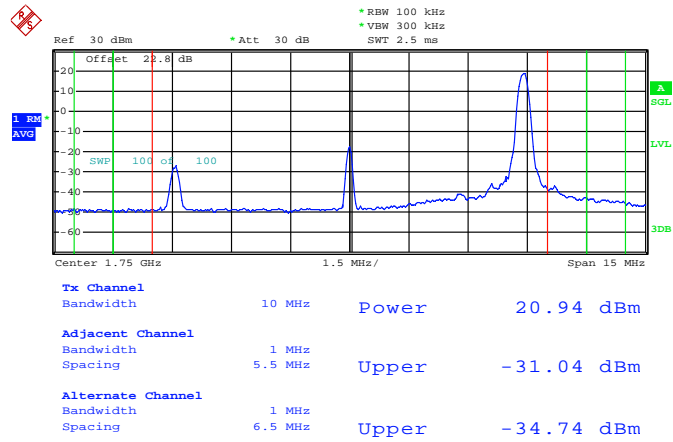

Date: 29.JUL.2013 17:43:10

Higher Band Edge Plot for 16QAM-RB Size 50, RB Offset 0

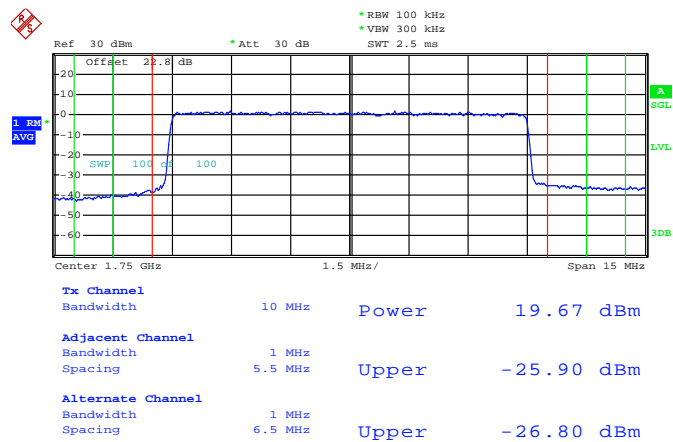

Date: 29.JUL.2013 17:45:23

Band :	LTE Band 4	Band Width :	15MHz / QPSK
---------------	------------	---------------------	--------------

Lower Band Edge Plot for QPSK-RB Size 1, RB Offset 0

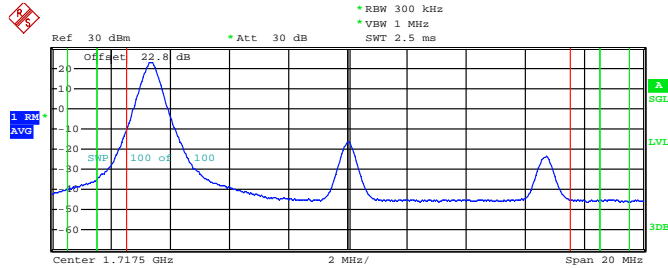

Tx Channel			
Bandwidth	15 MHz	Power	22.97 dBm
Adjacent Channel			
Bandwidth	1 MHz	Lower	-16.48 dBm
Spacing	8 MHz		
Alternate Channel			
Bandwidth	1 MHz	Lower	-33.29 dBm
Spacing	9 MHz		

Date: 29.JUL.2013 17:48:43

Lower Band Edge Plot for QPSK-RB Size 75, RB Offset 0

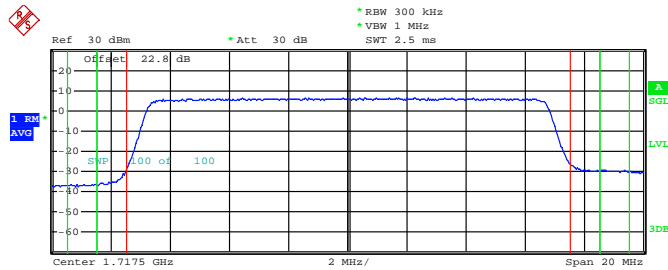

Tx Channel			
Bandwidth	15 MHz	Power	21.41 dBm
Adjacent Channel			
Bandwidth	1 MHz	Lower	-30.07 dBm
Spacing	8 MHz		
Alternate Channel			
Bandwidth	1 MHz	Lower	-32.23 dBm
Spacing	9 MHz		

Date: 29.JUL.2013 17:49:51

Higher Band Edge Plot for QPSK-RB Size 1, RB Offset 74

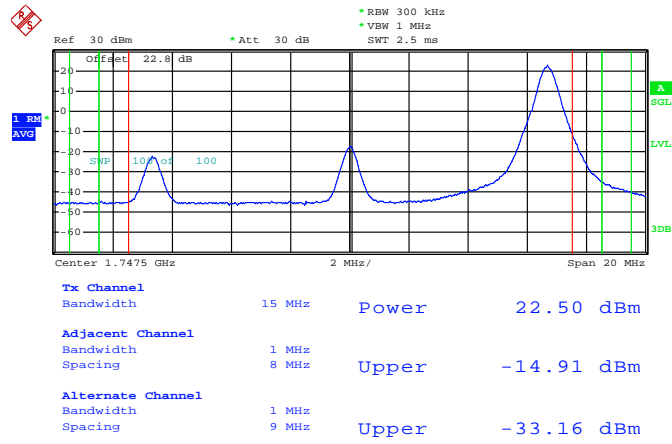

Date: 29.JUL.2013 17:47:58

Higher Band Edge Plot for QPSK-RB Size 75, RB Offset 0

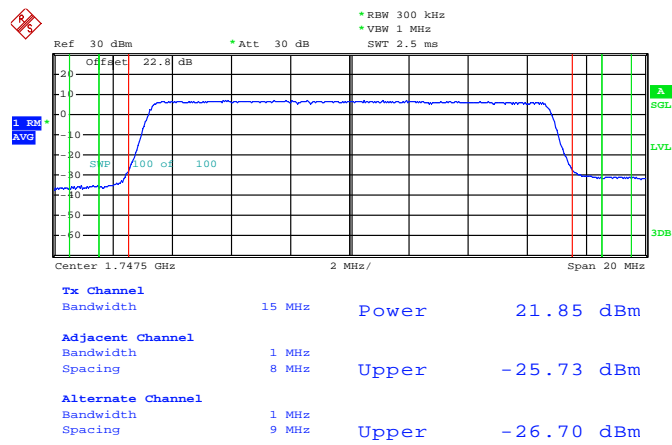

Date: 29.JUL.2013 17:47:05

Band :	LTE Band 4	Band Width :	15MHz / 16QAM
---------------	------------	---------------------	---------------

Lower Band Edge Plot for 16QAM-RB Size 1, RB Offset 0

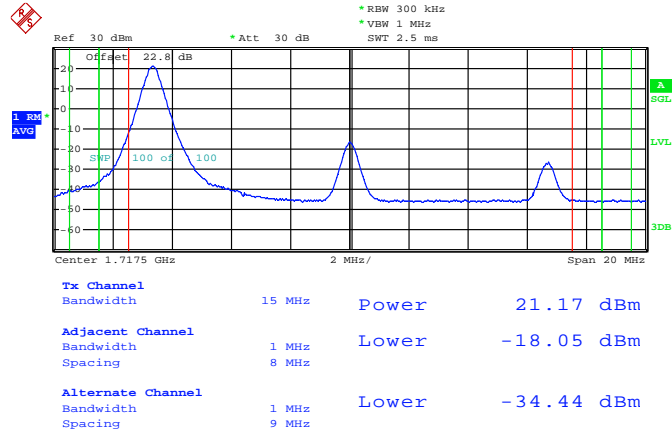

Date: 29.JUL.2013 17:48:58

Lower Band Edge Plot for 16QAM-RB Size 75, RB Offset 0

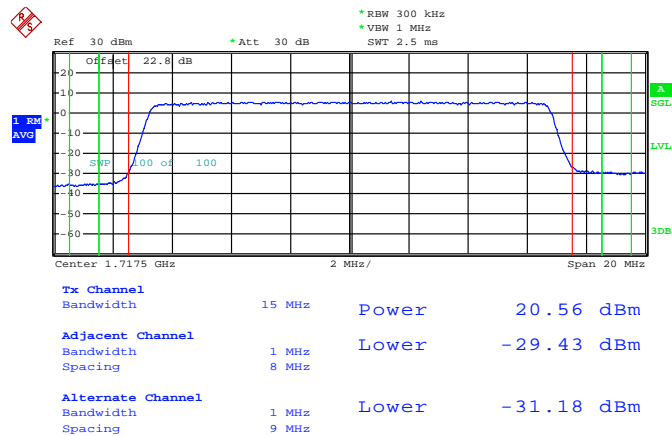

Date: 29.JUL.2013 17:49:38

Higher Band Edge Plot for 16QAM-RB Size 1, RB Offset 74

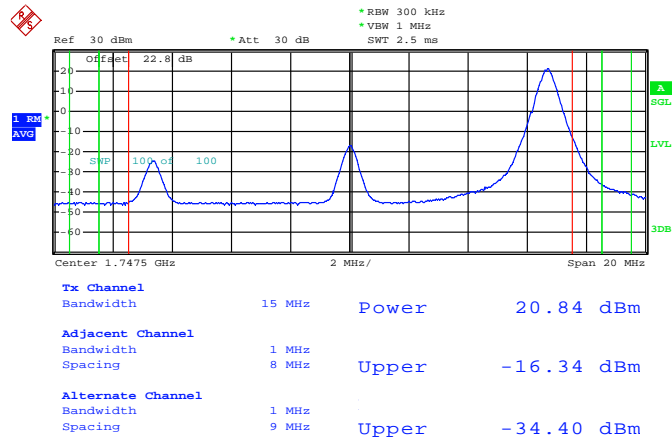

Date: 29.JUL.2013 17:47:45

Higher Band Edge Plot for 16QAM-RB Size 75, RB Offset 0

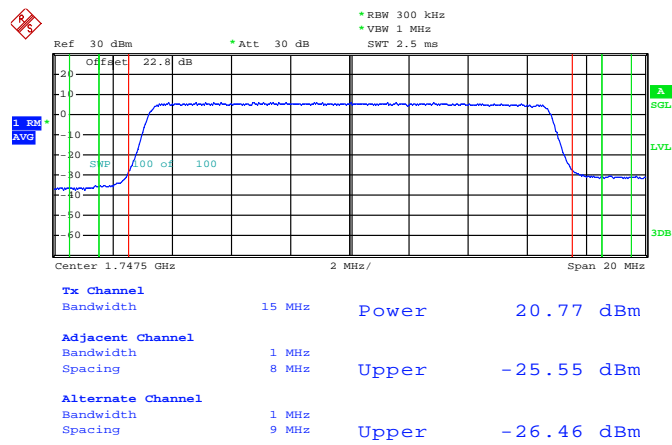

Date: 29.JUL.2013 17:47:26

Band :	LTE Band 4	Band Width :	20MHz / QPSK
---------------	------------	---------------------	--------------

Lower Band Edge Plot for QPSK-RB Size 1, RB Offset 0

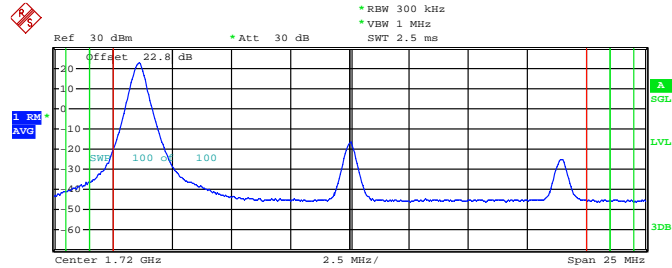

Tx Channel			
Bandwidth	20 MHz	Power	22.71 dBm
Adjacent Channel			
Bandwidth	1 MHz	Lower	-23.98 dBm
Spacing	10.5 MHz		
Alternate Channel			
Bandwidth	1 MHz	Lower	-34.18 dBm
Spacing	11.5 MHz		

Date: 29.JUL.2013 17:51:43

Lower Band Edge Plot for QPSK-RB Size 100, RB Offset 0

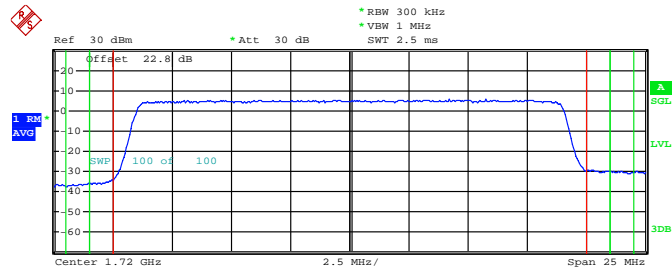

Tx Channel			
Bandwidth	20 MHz	Power	21.74 dBm
Adjacent Channel			
Bandwidth	1 MHz	Lower	-31.02 dBm
Spacing	10.5 MHz		
Alternate Channel			
Bandwidth	1 MHz	Lower	-32.18 dBm
Spacing	11.5 MHz		

Date: 29.JUL.2013 17:50:58

Higher Band Edge Plot for QPSK-RB Size 1, RB Offset 99

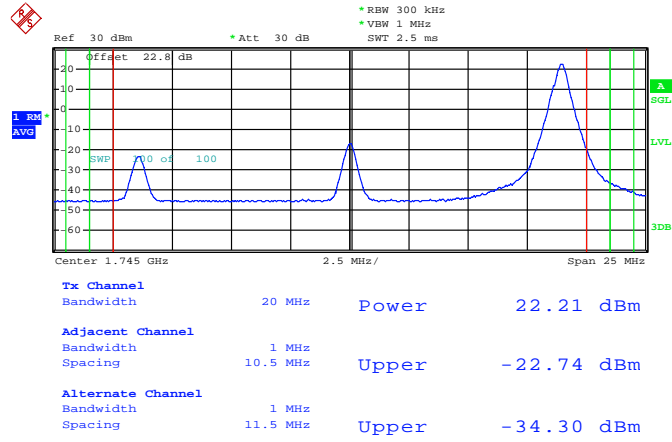

Date: 29.JUL.2013 17:52:35

Higher Band Edge Plot for QPSK-RB Size 100, RB Offset 0

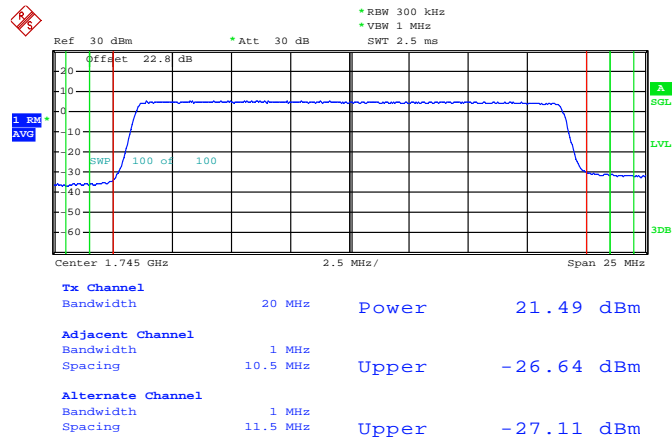

Date: 29.JUL.2013 17:53:24

Band :	LTE Band 4	Band Width :	20MHz / 16QAM
---------------	------------	---------------------	---------------

Lower Band Edge Plot for 16QAM-RB Size 1, RB Offset 0

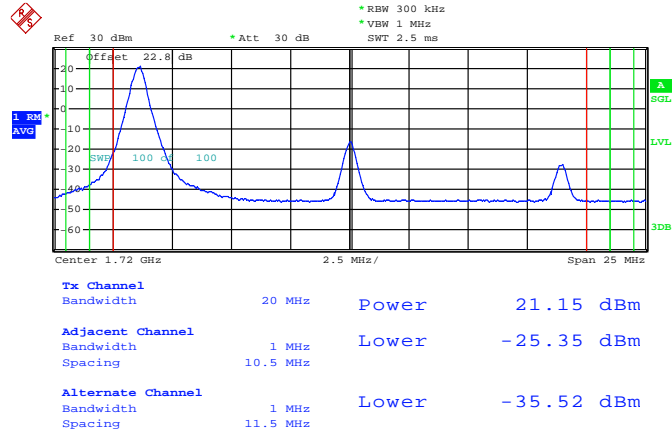

Date: 29.JUL.2013 17:51:29

Lower Band Edge Plot for 16QAM-RB Size 100, RB Offset 0

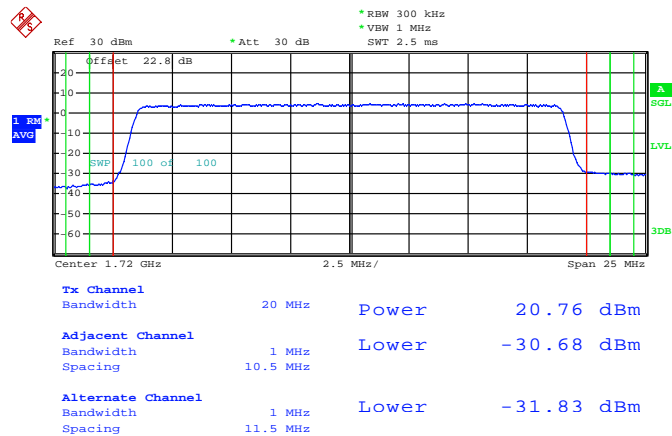

Date: 29.JUL.2013 17:51:14

Higher Band Edge Plot for 16QAM-RB Size 1, RB Offset 99

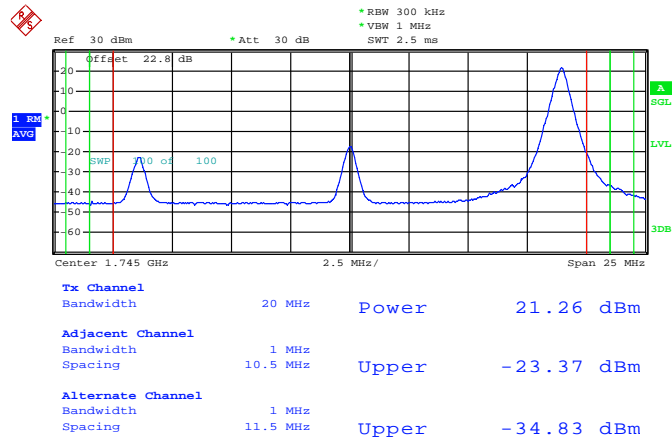

Date: 29.JUL.2013 17:52:49

Higher Band Edge Plot for 16QAM-RB Size 100, RB Offset 0

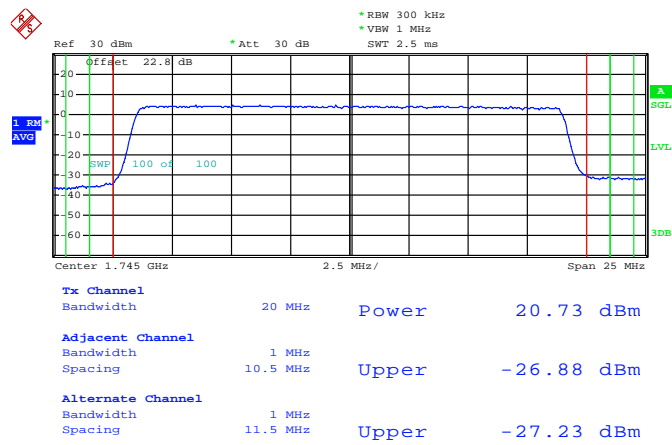

Date: 29.JUL.2013 17:53:09

Band :	LTE Band 13	Band Width :	5MHz / QPSK
---------------	-------------	---------------------	-------------

Lower Band Edge Plot for QPSK-RB Size 1, RB Offset 0

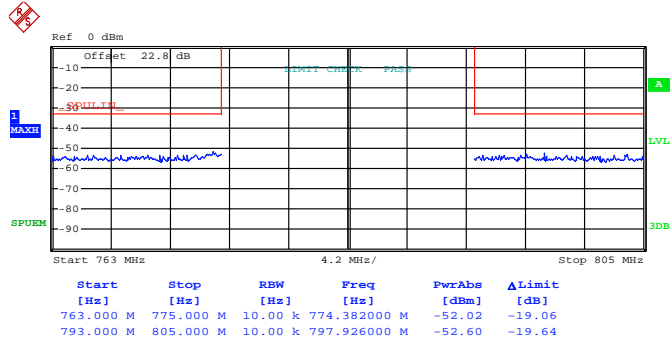

Date: 29.JUL.2013 16:36:55

Lower Band Edge Plot for QPSK-RB Size 25, RB Offset 0

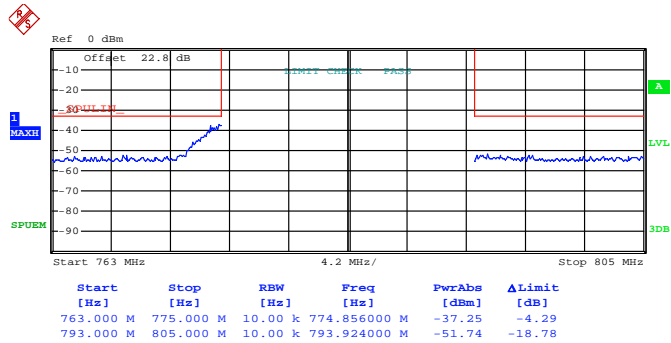

Date: 29.JUL.2013 16:36:12

Higher Band Edge Plot for QPSK-RB Size 1, RB Offset 24

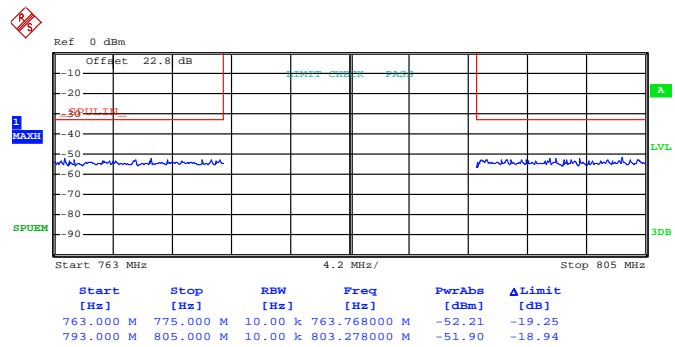

Date: 29.JUL.2013 16:37:32

Higher Band Edge Plot for QPSK-RB Size 25, RB Offset 0

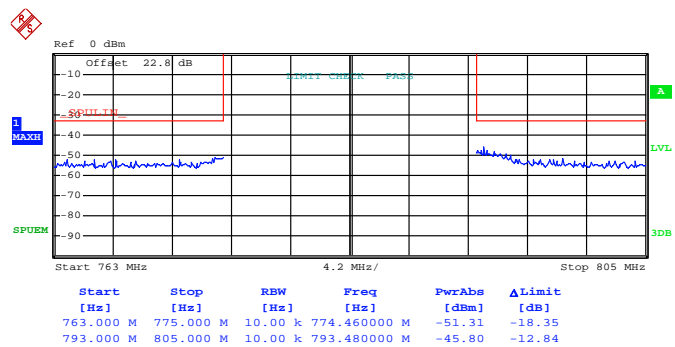

Date: 29.JUL.2013 16:38:31

Band :	LTE Band 13	Band Width :	5MHz / 16QAM
---------------	-------------	---------------------	--------------

Lower Band Edge Plot for 16QAM-RB Size 1, RB Offset 0

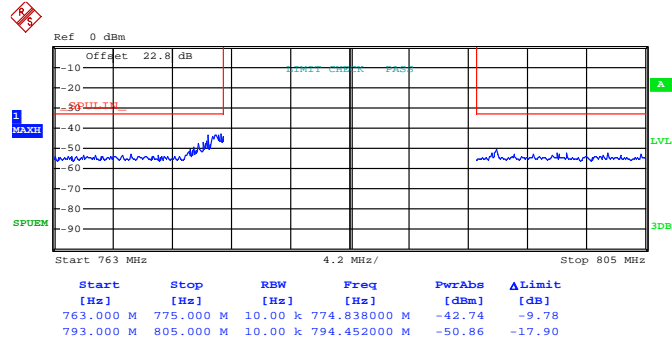

Date: 29.JUL.2013 16:36:42

Lower Band Edge Plot for 16QAM-RB Size 25, RB Offset 0

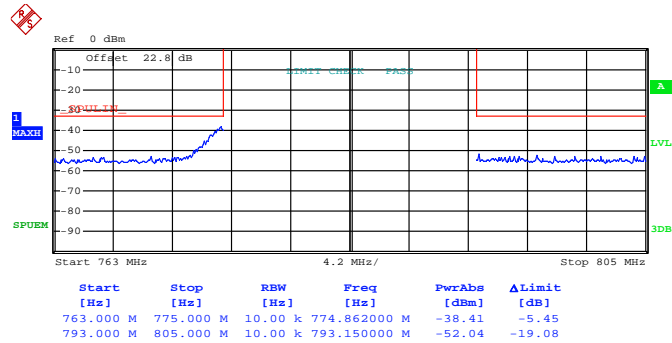

Date: 29.JUL.2013 16:36:26

Higher Band Edge Plot for 16QAM-RB Size 1, RB Offset 24

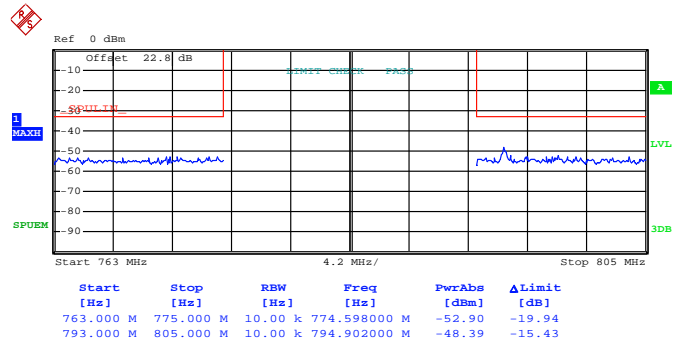

Date: 29.JUL.2013 16:37:48

Higher Band Edge Plot for 16QAM-RB Size 25, RB Offset 0

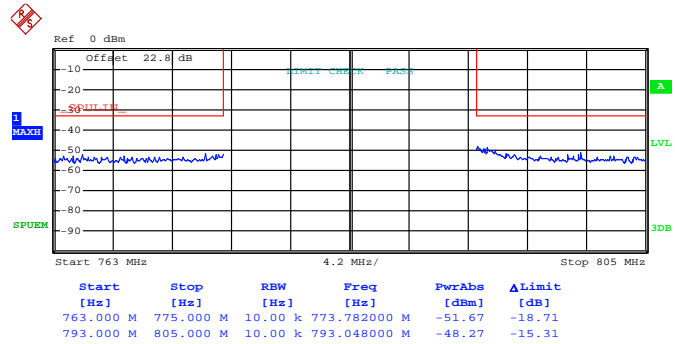

Date: 29.JUL.2013 16:38:15

Band :	LTE Band 13	Band Width :	10MHz / QPSK
---------------	-------------	---------------------	--------------

Middle Band Edge Plot for QPSK-RB Size 1, RB Offset 0

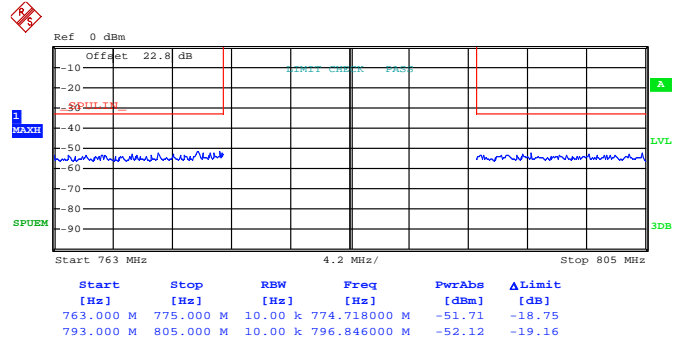

Date: 29.JUL.2013 16:40:17

Middle Band Edge Plot for QPSK-RB Size 1, RB Offset 49

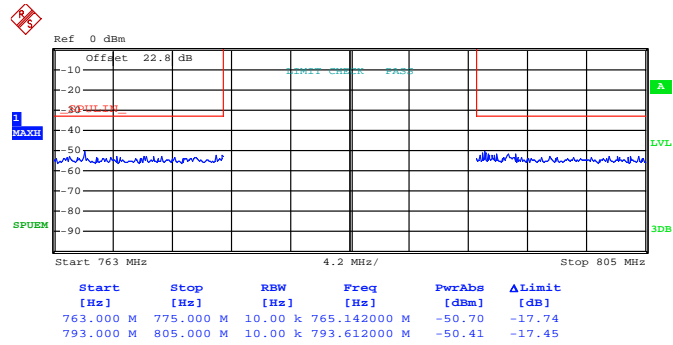

Date: 29.JUL.2013 16:40:36

Middle Band Edge Plot for QPSK-RB Size 50, RB Offset 0

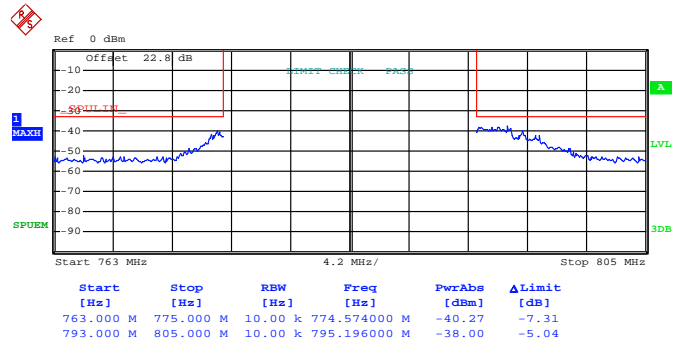

Date: 29.JUL.2013 16:39:26

Band :	LTE Band 13	Band Width :	10MHz / 16QAM
---------------	-------------	---------------------	---------------

Middle Band Edge Plot for 16QAM-RB Size 1, RB Offset 0

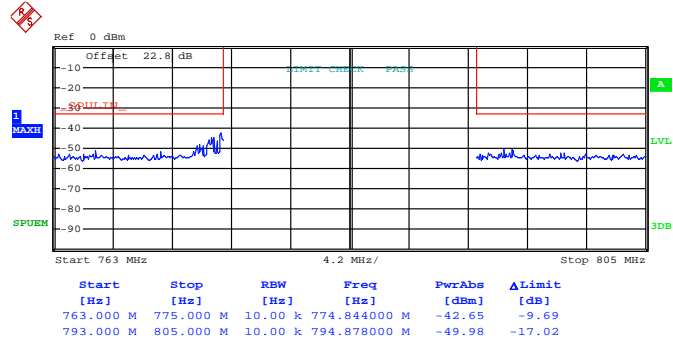

Date: 29.JUL.2013 16:40:00

Middle Band Edge Plot for 16QAM-RB Size 1, RB Offset 49

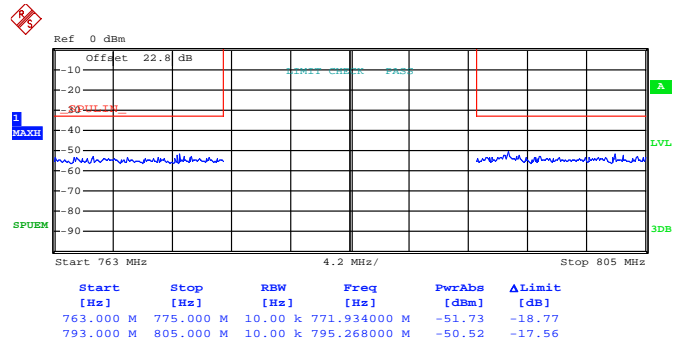

Date: 29.JUL.2013 16:40:51

Middle Band Edge Plot for 16QAM-RB Size 50, RB Offset 0

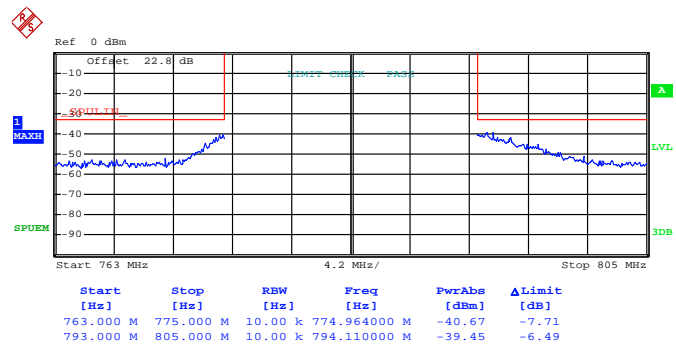

Date: 29.JUL.2013 16:39:40

3.5 Conducted Spurious Emission Measurement

3.5.1 Description of Conducted Spurious Emission Measurement

The power of any emission outside of the authorized operating frequency ranges must be lower than the transmitter power (P) by a factor of at least $43 + 10 \log (P)$ dB.

It is measured by means of a calibrated spectrum analyzer and scanned from 9 kHz up to a frequency including its 10th harmonic.

3.5.2 Measuring Instruments

Measuring equipment is listed in the section 4 of this test report.

3.5.3 Test Procedures

1. The EUT was connected to spectrum analyzer and base station via power divider.
2. The RF output of EUT was connected to the spectrum analyzer by RF cable and attenuator. The path loss was compensated to the results for each measurement.
3. The middle channel for the highest RF power within the transmitting frequency was measured.
4. The conducted spurious emission for the whole frequency range was taken.
5. Make the measurement with the spectrum analyzer's RBW = 1MHz, VBW = 3MHz, taking the record of maximum spurious emission.
6. The RF fundamental frequency should be excluded against the limit line in the operating frequency band.
7. The limit line is derived from $43 + 10\log(P)$ dB below the transmitter power P(Watts)
= $P(W) - [43 + 10\log(P)]$ (dB)
= $[30 + 10\log(P)]$ (dBm) - $[43 + 10\log(P)]$ (dB)
= -13dBm.

3.5.4 Test Setup

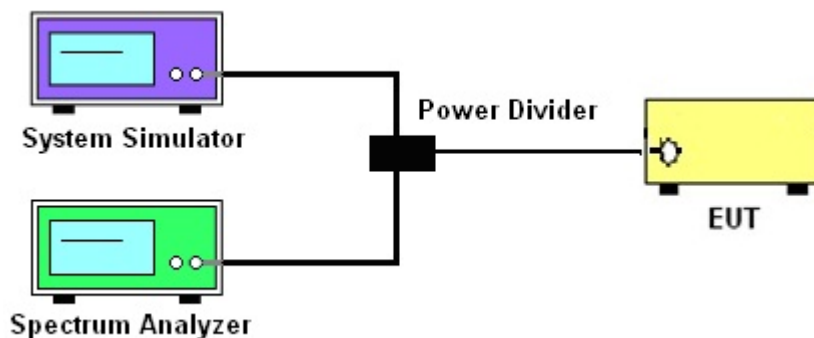

3.5.5 Test Result (Plots) of Conducted Spurious Emission

Band :	LTE Band 4	Channel :	CH19957 (Low)
Band Width :	1.4MHz		

QPSK (RB Size 1, RB Offset 0)

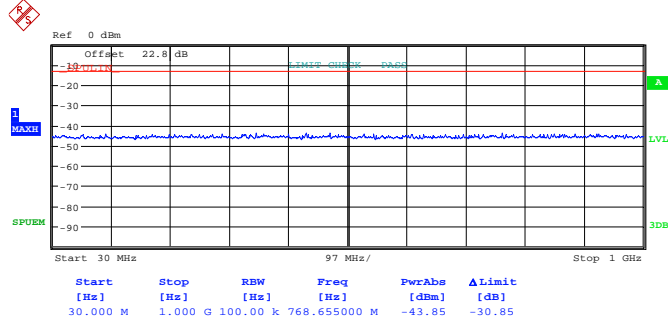

Date: 26.AUG.2013 09:57:43

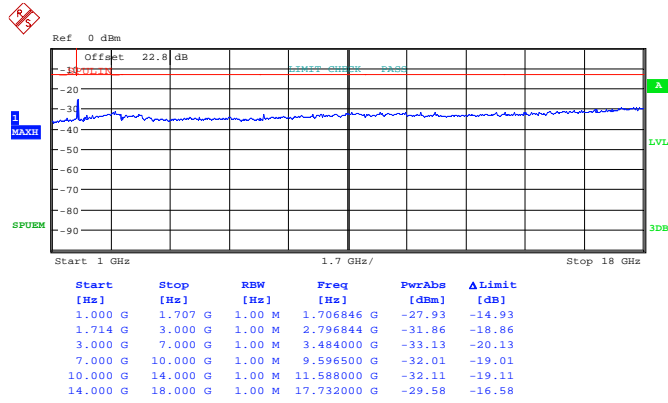

Date: 26.AUG.2013 09:58:17

16QAM (RB Size 1, RB Offset 0)

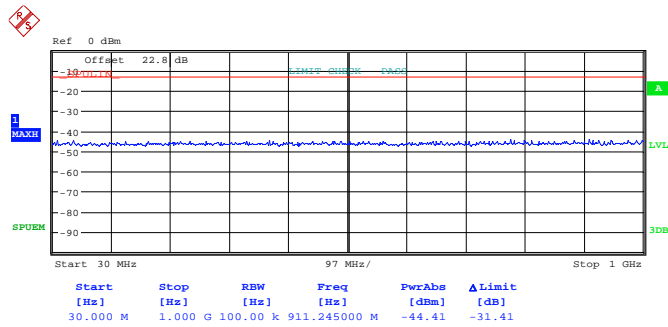

Date: 26.AUG.2013 09:57:54

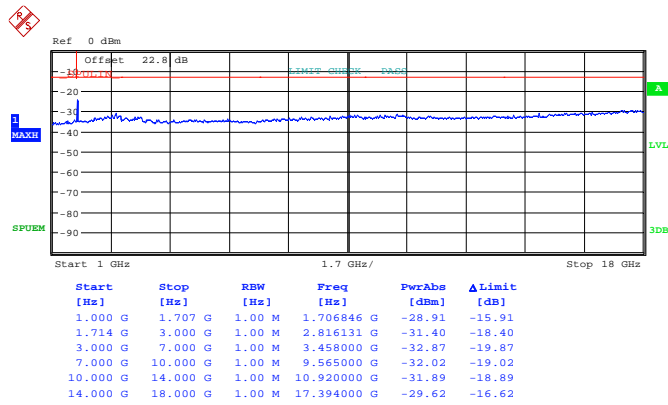

Date: 26.AUG.2013 09:58:07

Band :	LTE Band 4	Channel :	CH20175 (Middle)
Band Width :	1.4MHz		

QPSK (RB Size 1, RB Offset 0)

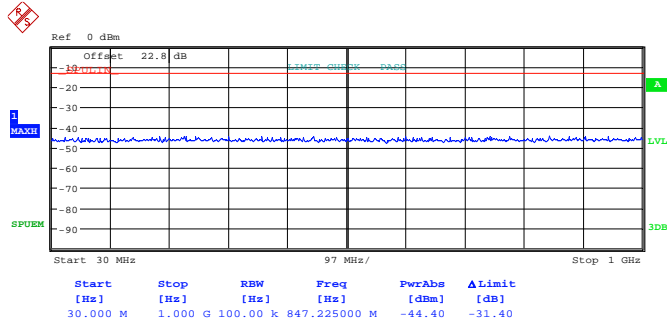

Date: 26.AUG.2013 09:55:40

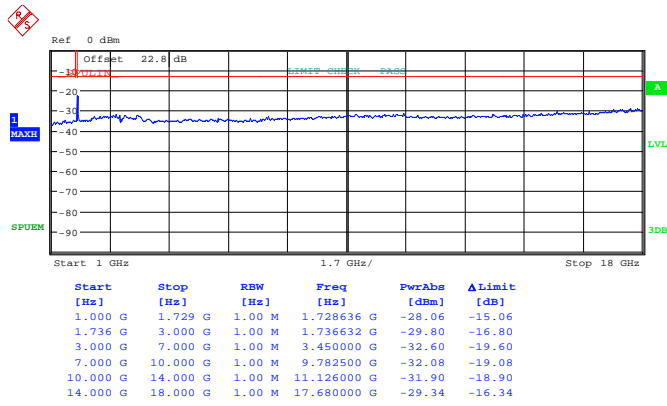

Date: 26.AUG.2013 09:55:03

16QAM (RB Size 1, RB Offset 0)

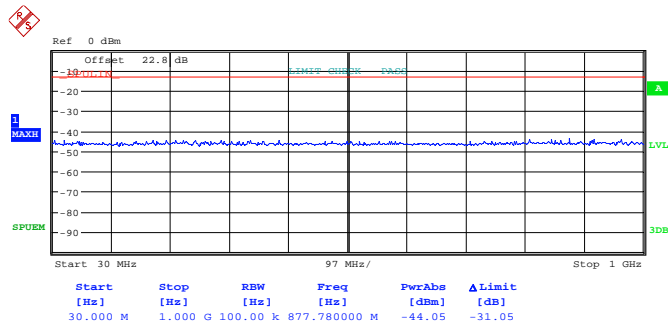

Date: 26.AUG.2013 09:55:28

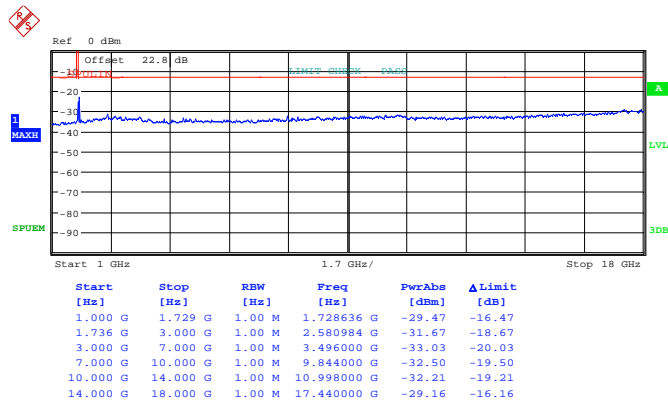

Date: 26.AUG.2013 09:55:15

Band :	LTE Band 4	Channel :	CH20393 (High)
Band Width :	1.4MHz		

QPSK (RB Size 1, RB Offset 0)

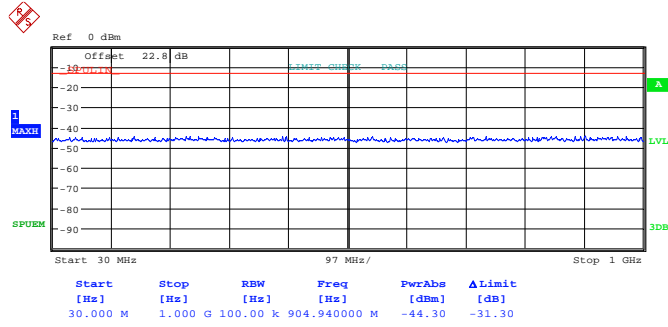

Date: 26.AUG.2013 09:59:54

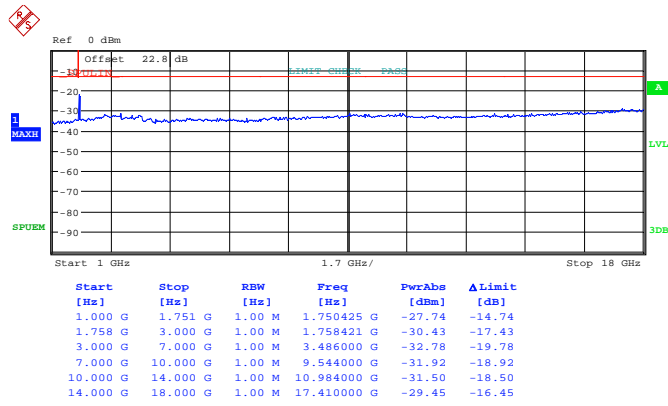

Date: 26.AUG.2013 09:59:14

16QAM (RB Size 1, RB Offset 0)

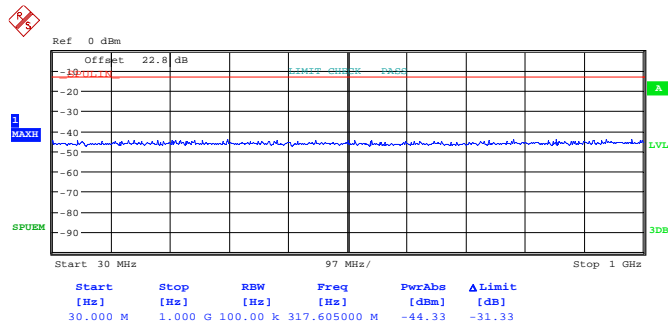

Date: 26.AUG.2013 09:59:40

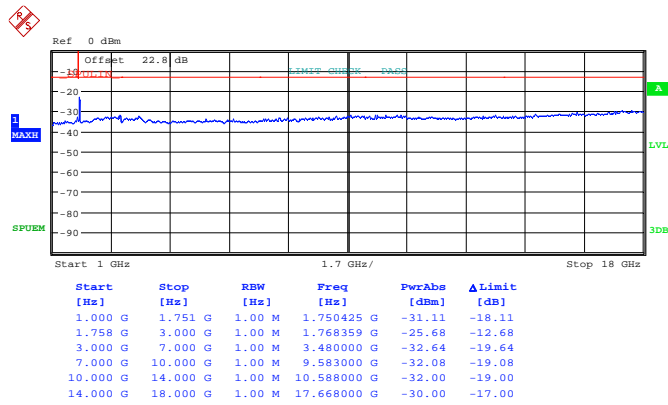

Date: 26.AUG.2013 09:59:26

Band :	LTE Band 4	Channel :	CH19965 (Low)
Band Width :	3MHz		

QPSK (RB Size 1, RB Offset 14)

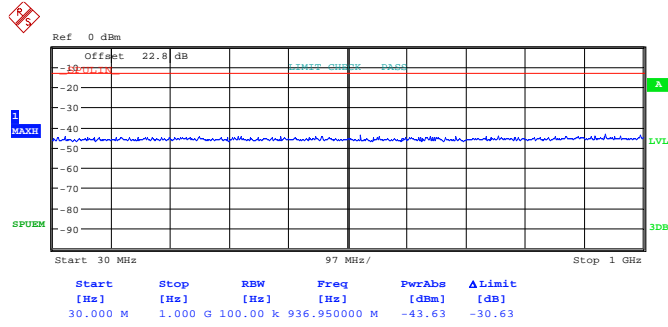

Date: 26.AUG.2013 09:48:27

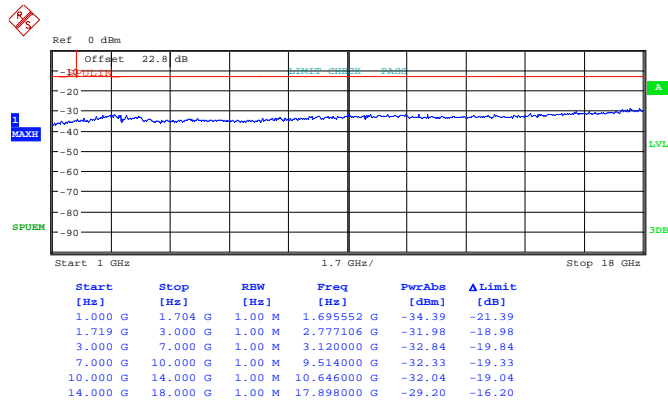

Date: 26.AUG.2013 09:49:11

16QAM (RB Size 1, RB Offset 14)

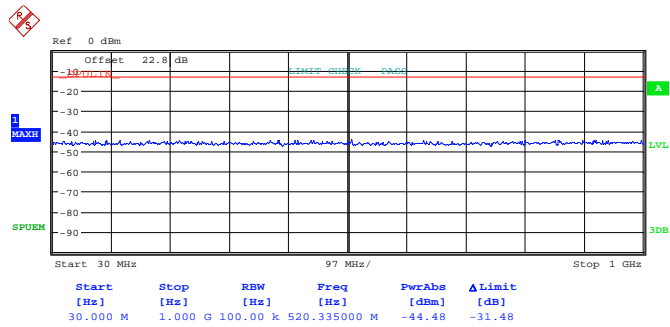

Date: 26.AUG.2013 09:48:41

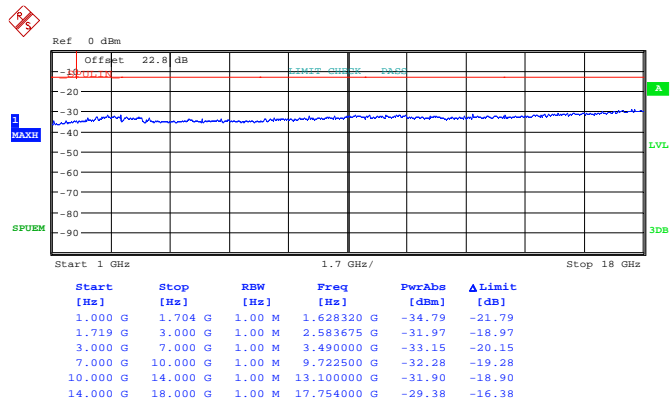

Date: 26.AUG.2013 09:48:59

Band :	LTE Band 4	Channel :	CH20175 (Middle)
Band Width :	3MHz		

QPSK (RB Size 1, RB Offset 0)

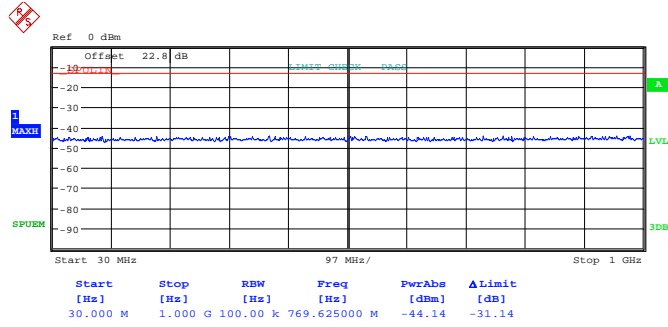

Date: 26.AUG.2013 09:52:50

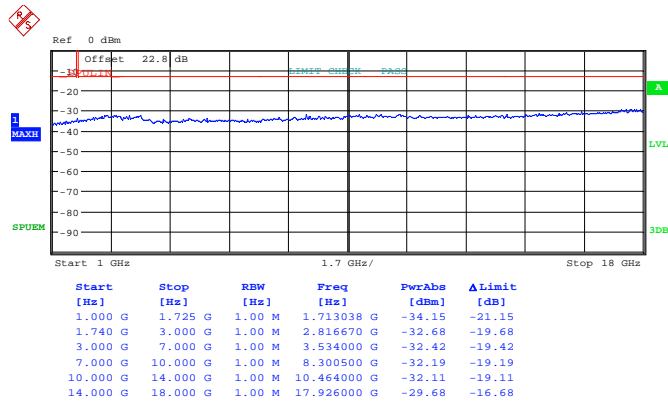

Date: 26.AUG.2013 09:53:37

16QAM (RB Size 1, RB Offset 0)

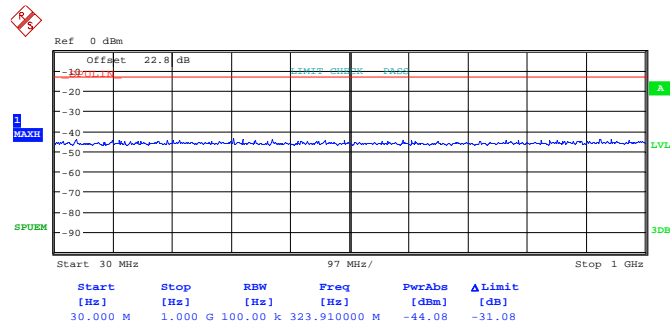

Date: 26.AUG.2013 09:53:07

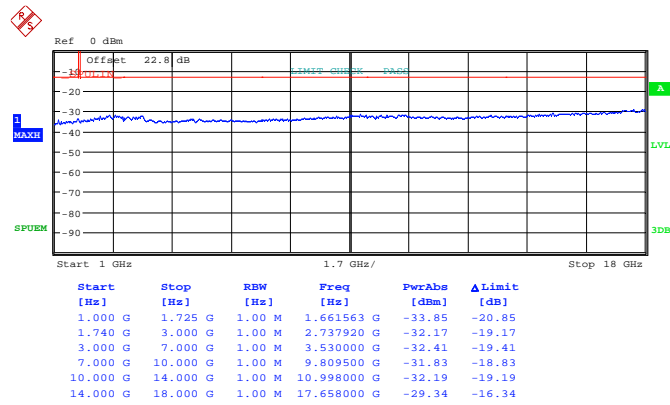

Date: 26.AUG.2013 09:53:25

Band :	LTE Band 4	Channel :	CH20385 (High)
Band Width :	3MHz		

QPSK (RB Size 1, RB Offset 7)

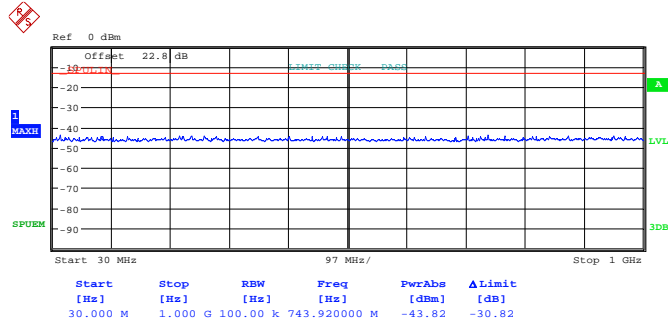

Date: 26.AUG.2013 09:51:22

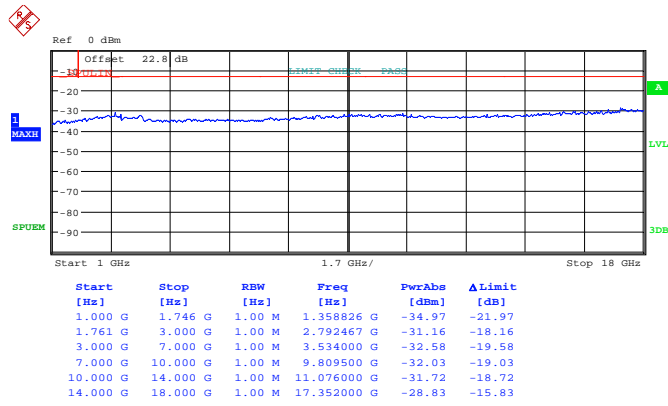

Date: 26.AUG.2013 09:50:42

16QAM (RB Size 1, RB Offset 7)

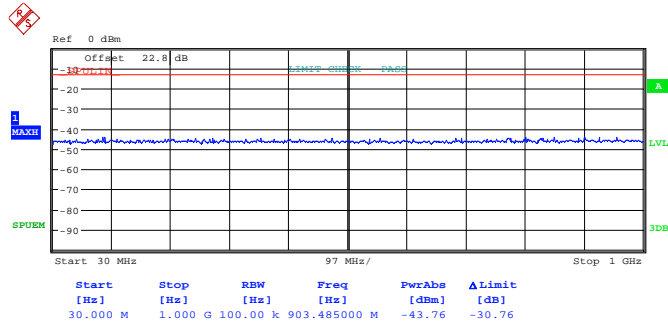

Date: 26.AUG.2013 09:51:07

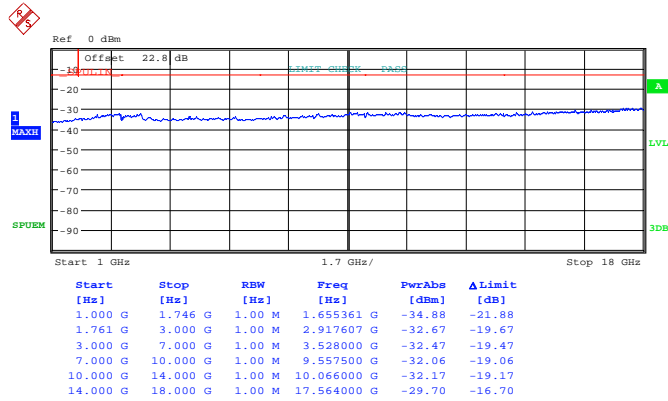

Date: 26.AUG.2013 09:50:54

Band :	LTE Band 4	Channel :	CH19975 (Low)
Band Width :	5MHz		

QPSK (RB Size 1, RB Offset 24)

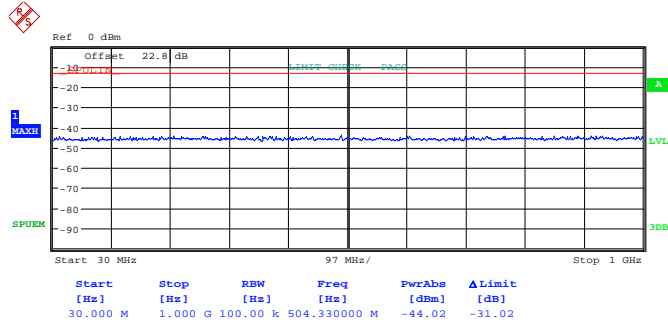

Date: 26.AUG.2013 10:01:58

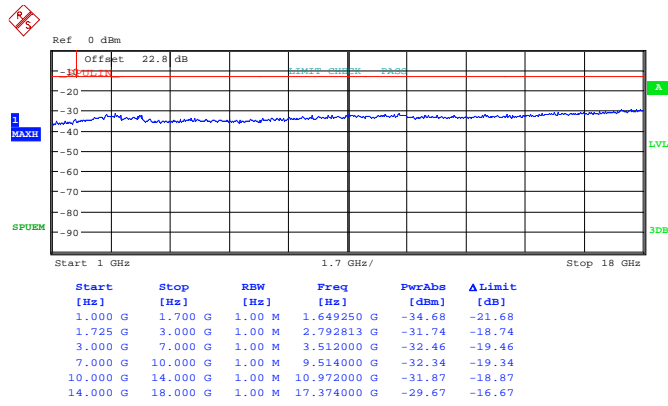

Date: 26.AUG.2013 10:02:45

16QAM (RB Size 1, RB Offset 24)

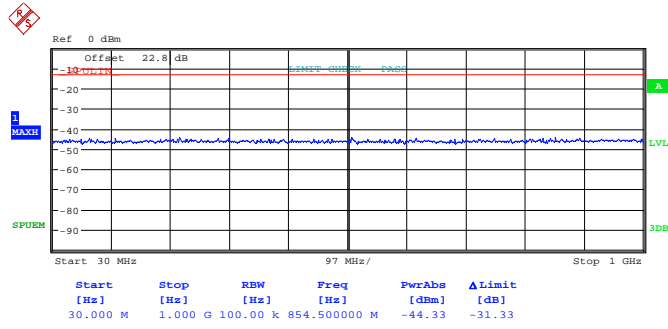

Date: 26.AUG.2013 10:02:15

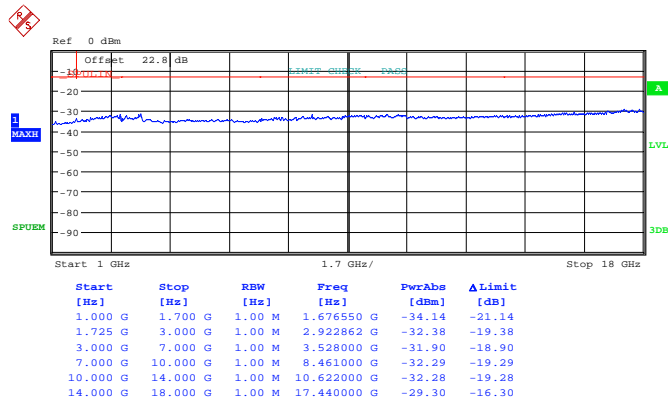

Date: 26.AUG.2013 10:02:31

Band :	LTE Band 4	Channel :	CH20175 (Middle)
Band Width :	5MHz		

QPSK (RB Size 1, RB Offset 0)

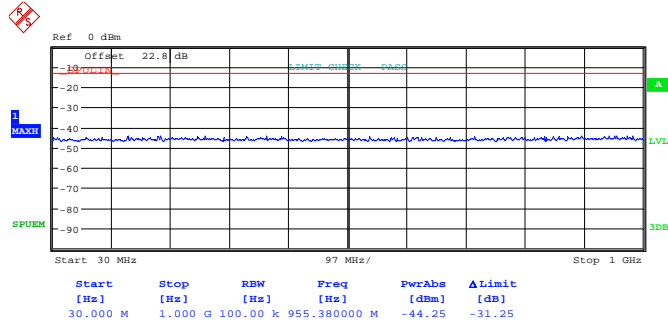

Date: 26.AUG.2013 10:05:05

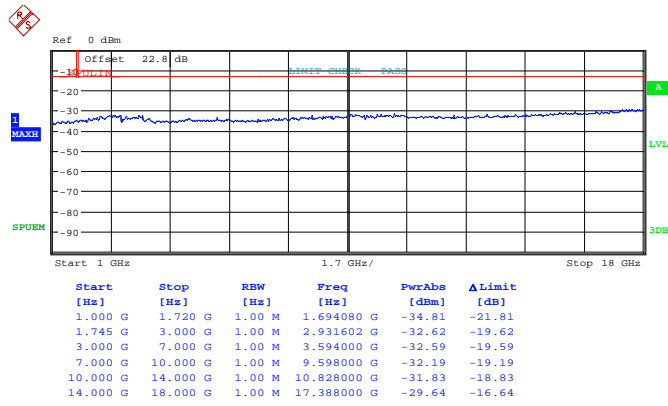

Date: 26.AUG.2013 10:05:58

16QAM (RB Size 1, RB Offset 0)

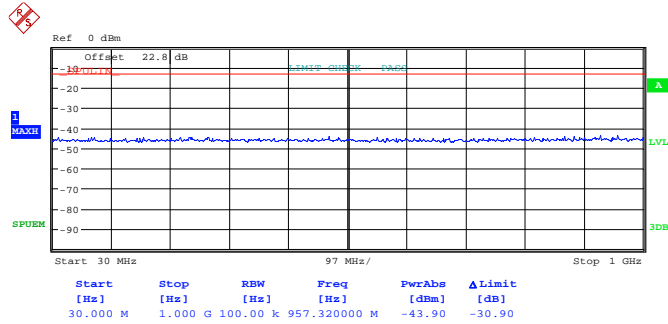

Date: 26.AUG.2013 10:05:21

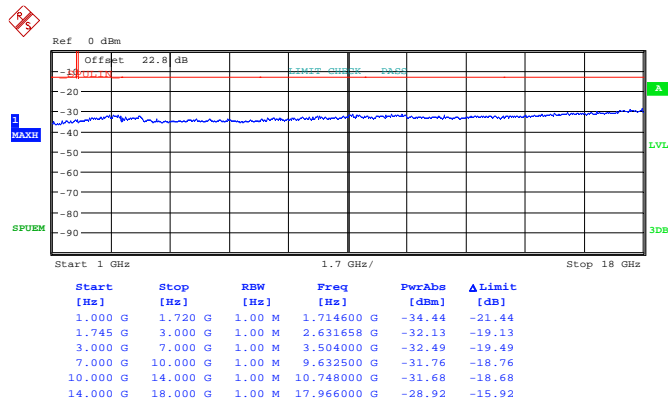

Date: 26.AUG.2013 10:05:43

Band :	LTE Band 4	Channel :	CH20375 (High)
Band Width :	5MHz		

QPSK (RB Size 1, RB Offset 0)

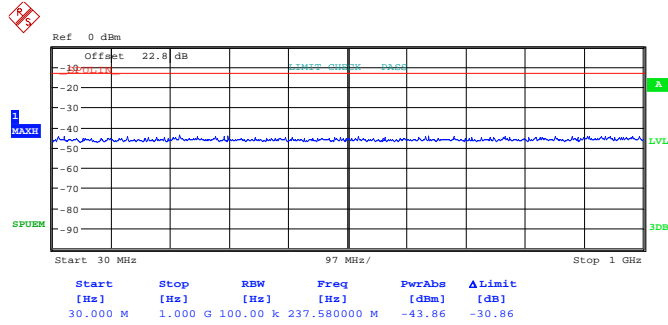

Date: 26.AUG.2013 10:04:35

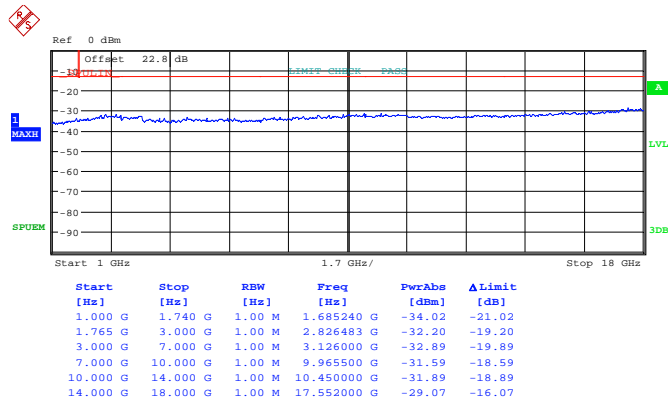

Date: 26.AUG.2013 10:03:29

16QAM (RB Size 1, RB Offset 0)

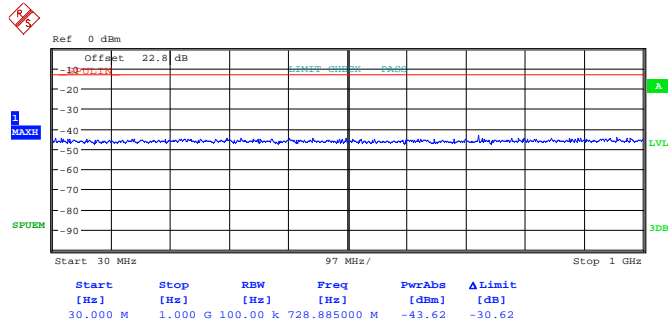

Date: 26.AUG.2013 10:04:22

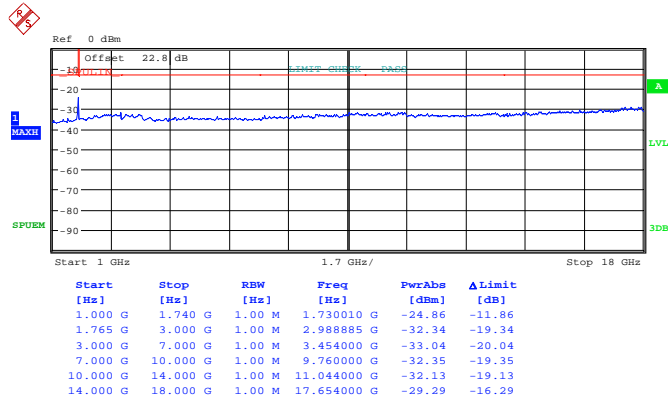

Date: 26.AUG.2013 10:04:07

Band :	LTE Band 4	Channel :	CH20000 (Low)
Band Width :	10MHz		

QPSK (RB Size 1, RB Offset 49)

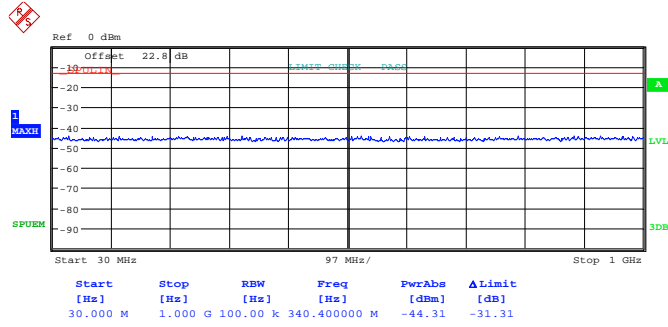

Date: 26.AUG.2013 10:13:21

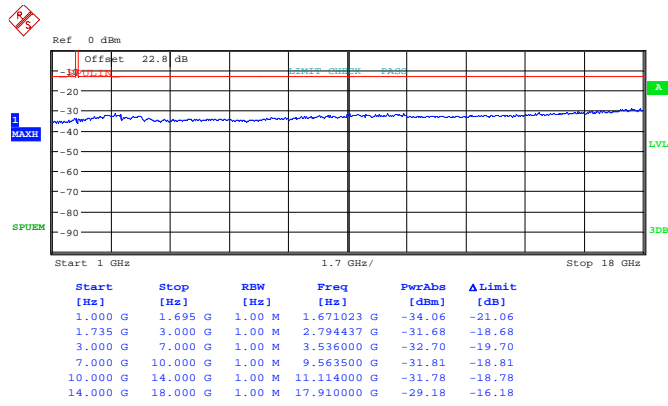

Date: 26.AUG.2013 10:11:26

16QAM (RB Size 1, RB Offset 49)

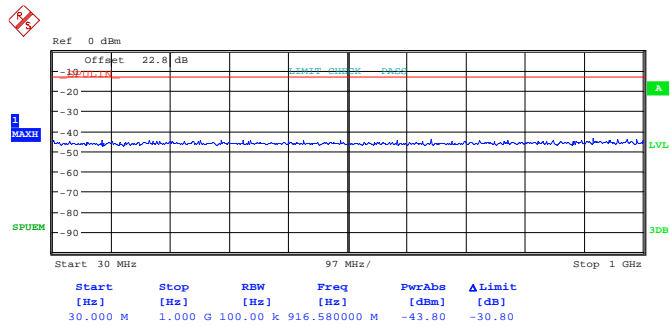

Date: 26.AUG.2013 10:13:00

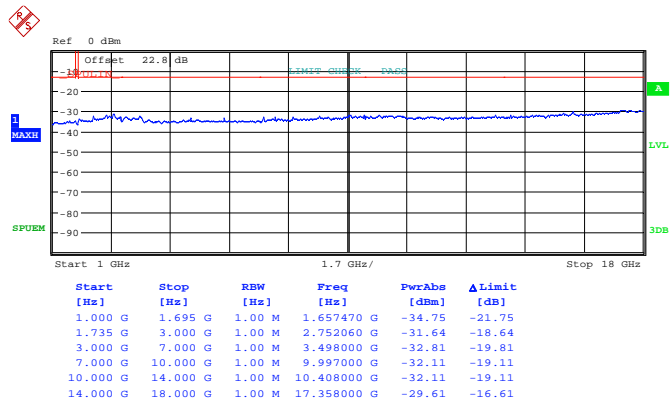

Date: 26.AUG.2013 10:12:46

Band :	LTE Band 4	Channel :	CH20175 (Middle)
Band Width :	10MHz		

QPSK (RB Size 1, RB Offset 0)

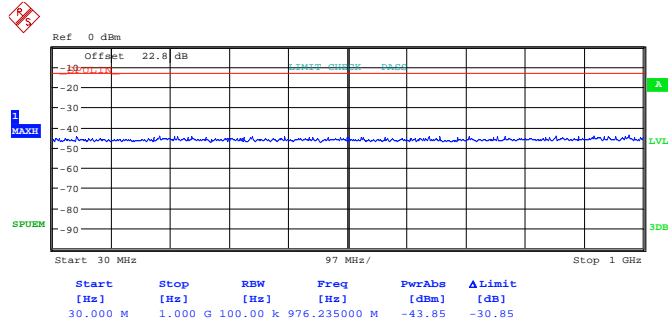

Date: 26.AUG.2013 10:08:32

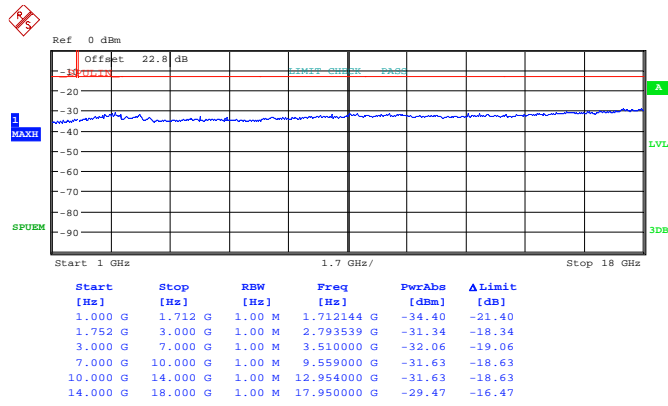

Date: 26.AUG.2013 10:07:42

16QAM (RB Size 1, RB Offset 0)

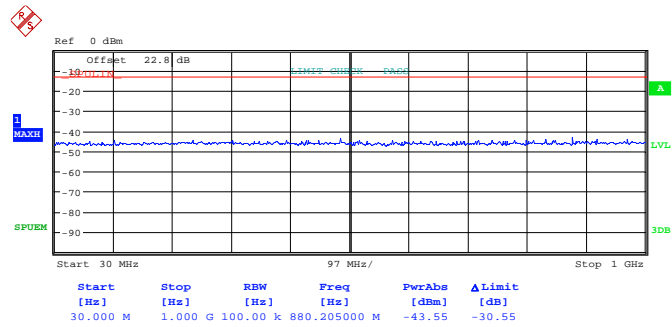

Date: 26.AUG.2013 10:08:17

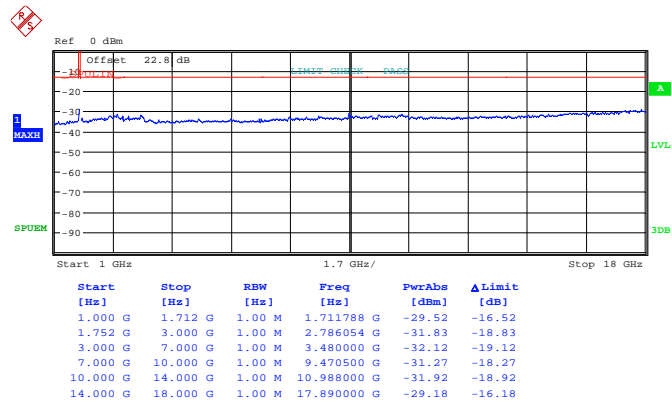

Date: 26.AUG.2013 10:08:01

Band :	LTE Band 4	Channel :	CH20350 (High)
Band Width :	10MHz		

QPSK (RB Size 1, RB Offset 0)

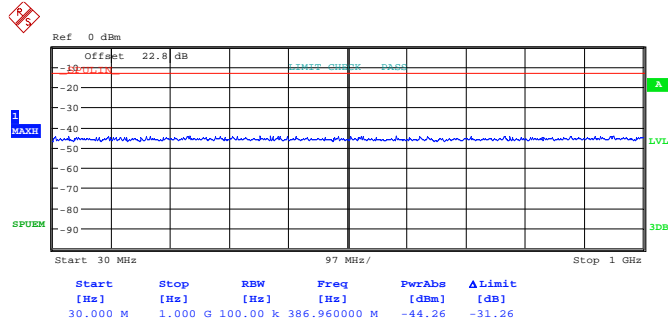

Date: 26.AUG.2013 10:09:18

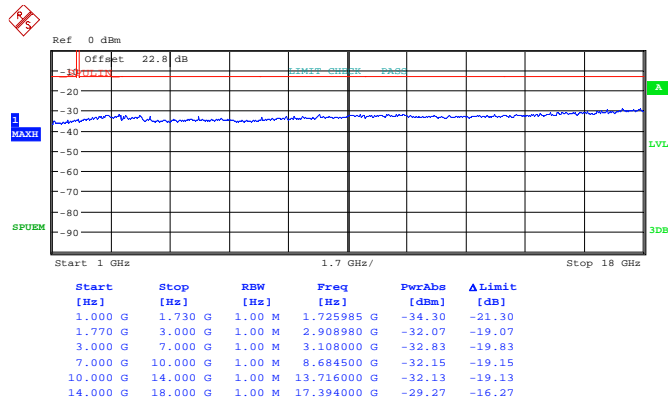

Date: 26.AUG.2013 10:10:25

16QAM (RB Size 1, RB Offset 0)

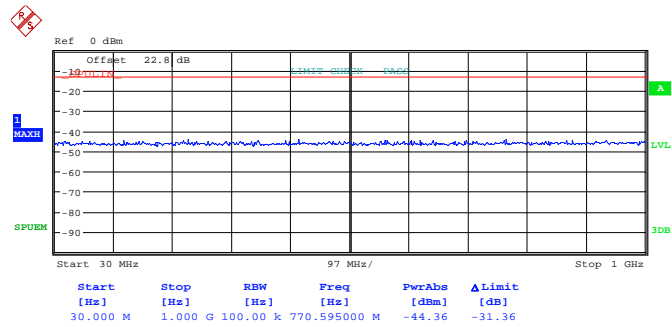

Date: 26.AUG.2013 10:09:32

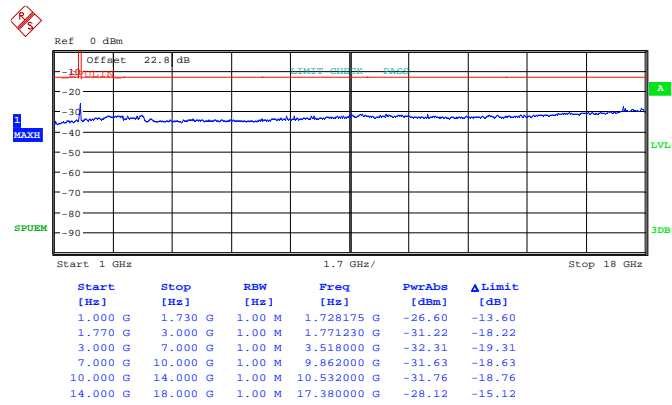

Date: 26.AUG.2013 10:10:06

Band :	LTE Band 4	Channel :	CH20025 (Low)
Band Width :	15MHz		

QPSK (RB Size 1, RB Offset 37)

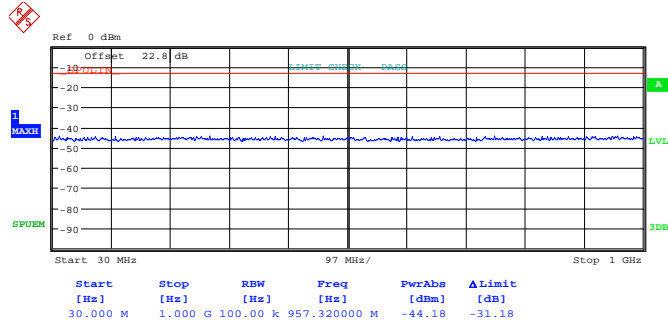

Date: 26.AUG.2013 10:18:09

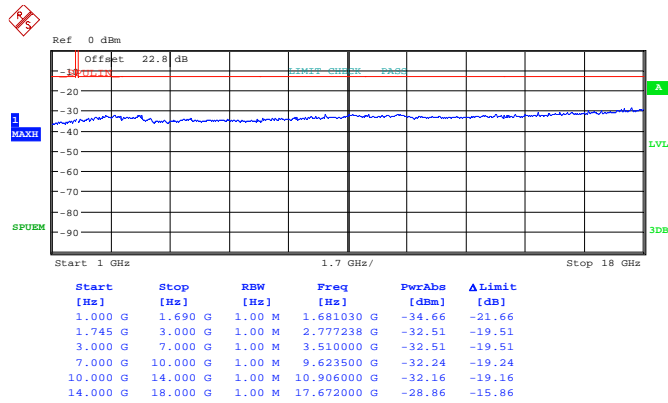

Date: 26.AUG.2013 10:19:01

16QAM (RB Size 1, RB Offset 37)

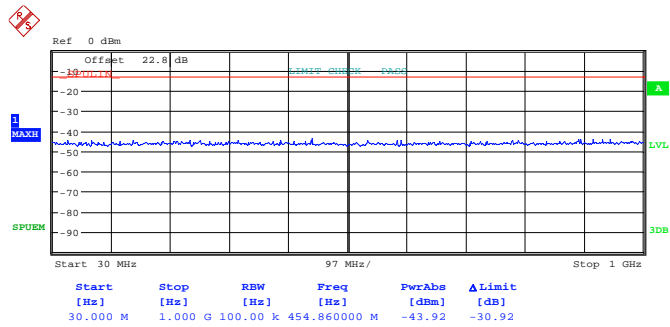

Date: 26.AUG.2013 10:18:22

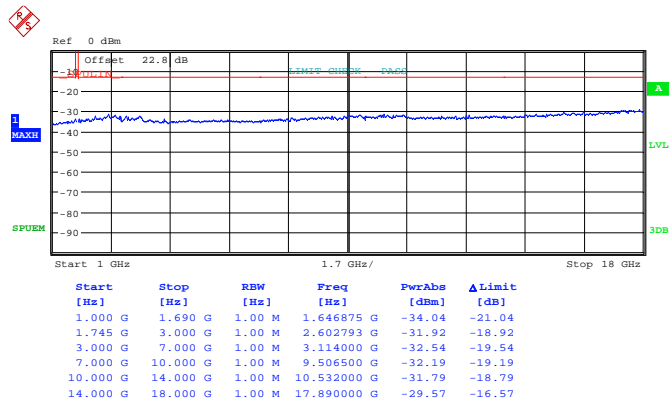

Date: 26.AUG.2013 10:18:44

Band :	LTE Band 4	Channel :	CH20175 (Middle)
Band Width :	15MHz		

QPSK (RB Size 1, RB Offset 0)

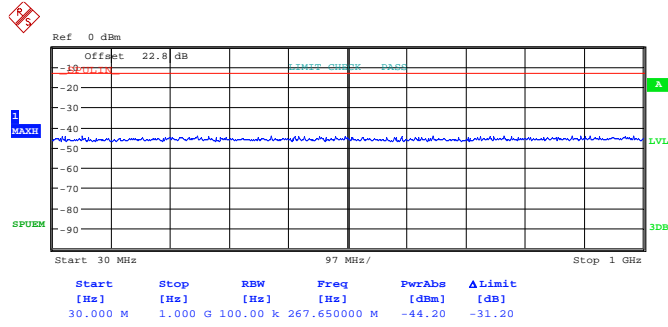

Date: 26.AUG.2013 10:25:18

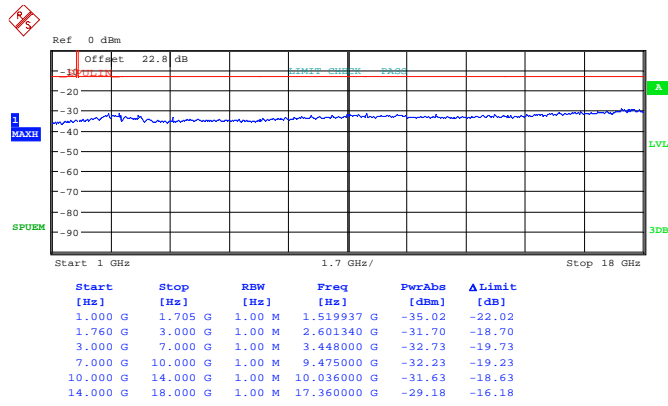

Date: 26.AUG.2013 10:26:05

16QAM (RB Size 1, RB Offset 0)

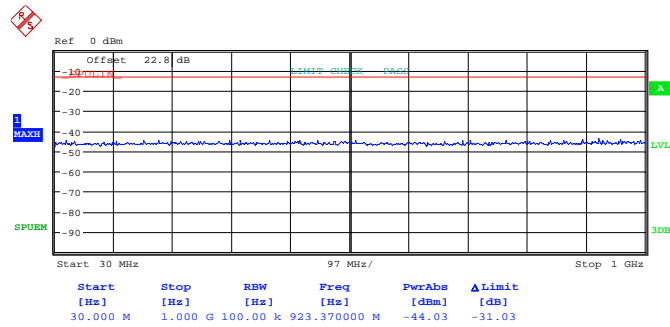

Date: 26.AUG.2013 10:25:33

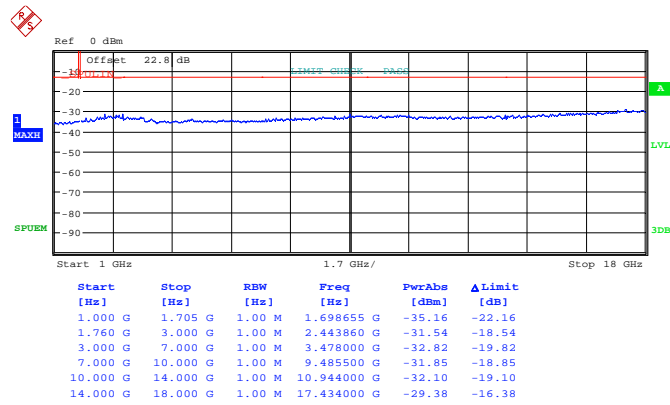

Date: 26.AUG.2013 10:25:52

Band :	LTE Band 4	Channel :	CH20325 (High)
Band Width :	15MHz		

QPSK (RB Size 1, RB Offset 37)

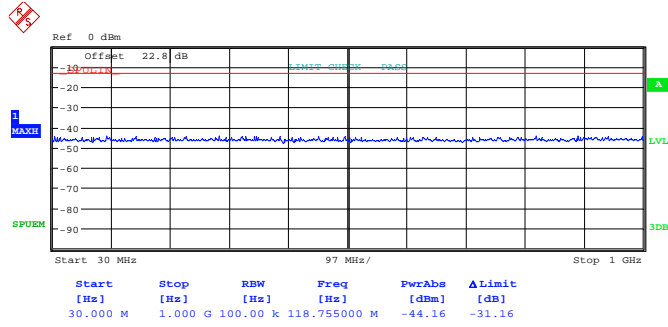

Date: 26.AUG.2013 10:24:03

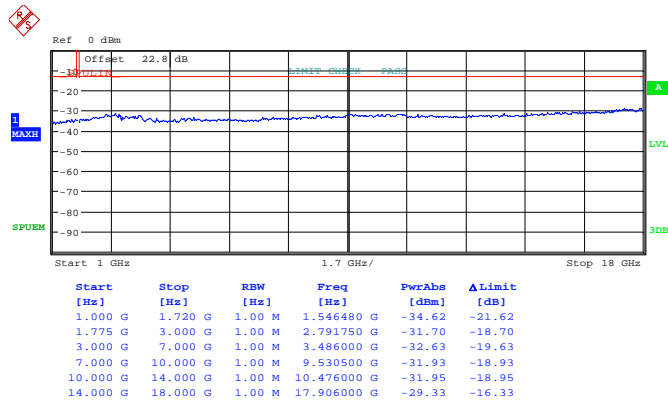

Date: 26.AUG.2013 10:23:20

16QAM (RB Size 1, RB Offset 37)

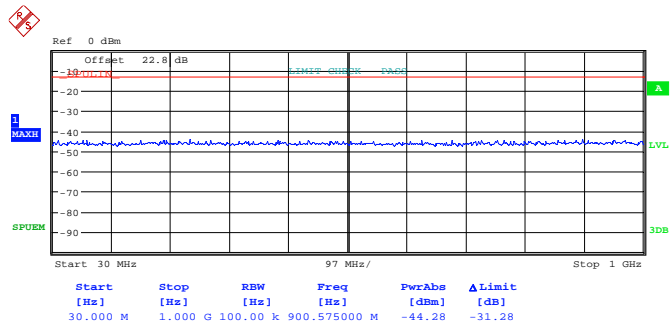

Date: 26.AUG.2013 10:23:52

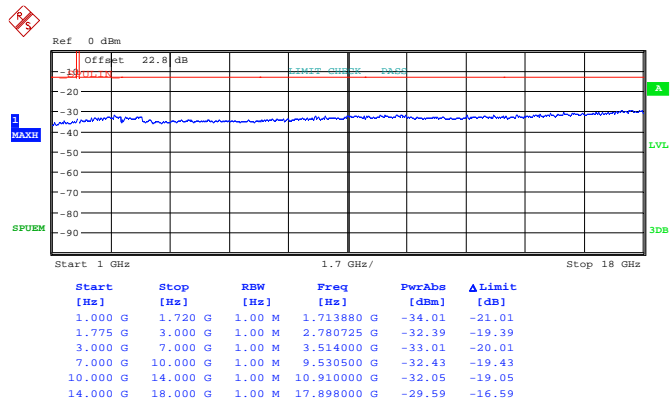

Date: 26.AUG.2013 10:23:36

Band :	LTE Band 4	Channel :	CH20050 (Low)
Band Width :	20MHz		

QPSK (RB Size 1, RB Offset 49)

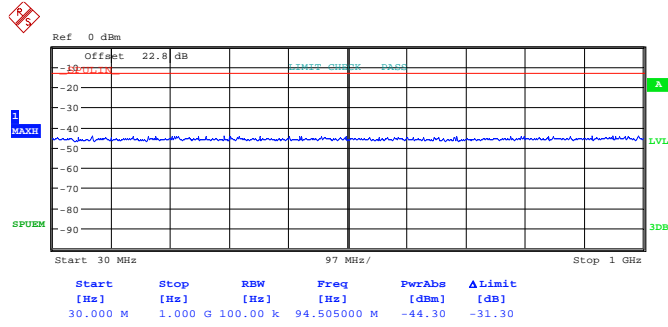

Date: 26.AUG.2013 10:29:55

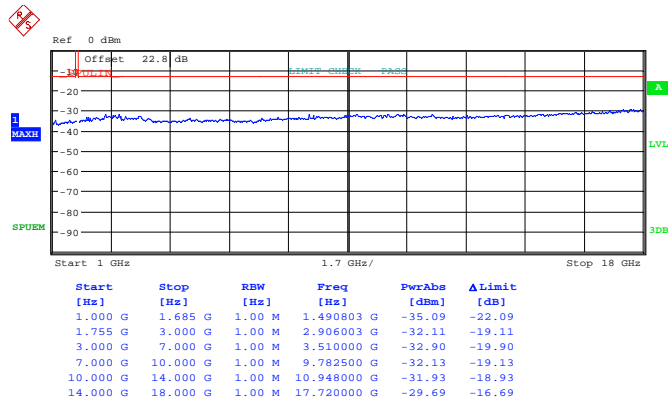

Date: 26.AUG.2013 10:30:44

16QAM (RB Size 1, RB Offset 49)

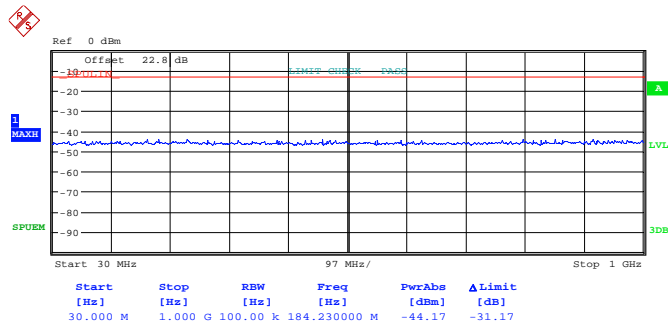

Date: 26.AUG.2013 10:30:11

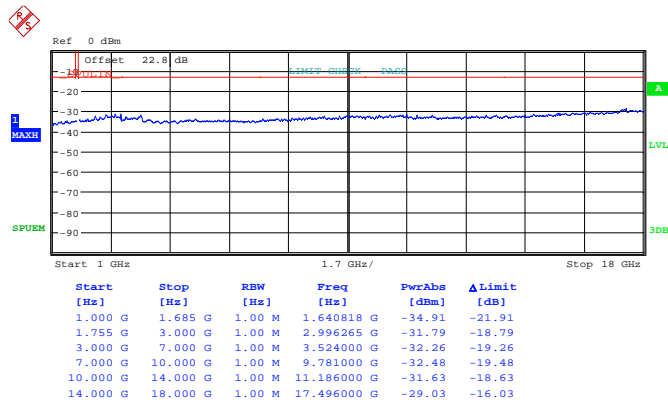

Date: 26.AUG.2013 10:30:31

Band :	LTE Band 4	Channel :	CH20175 (Middle)
Band Width :	20MHz		

QPSK (RB Size 1, RB Offset 49)

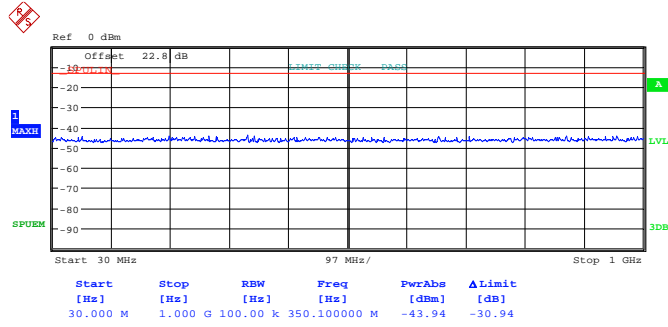

Date: 26.AUG.2013 10:28:29

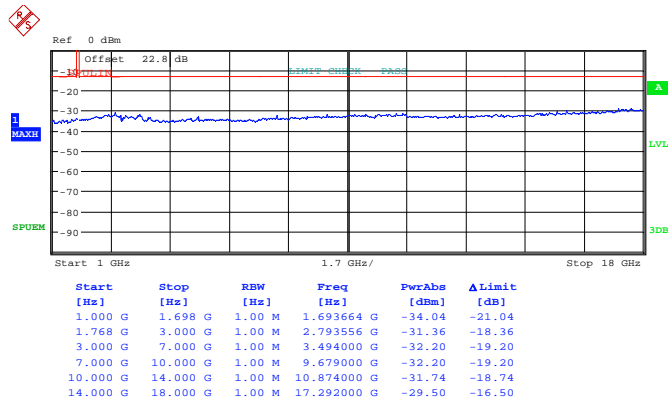

Date: 26.AUG.2013 10:27:48

16QAM (RB Size 1, RB Offset 49)

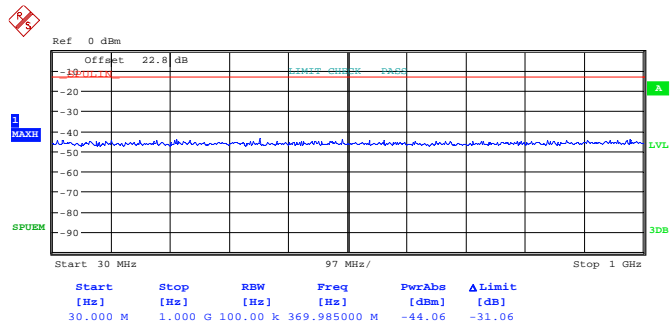

Date: 26.AUG.2013 10:28:18

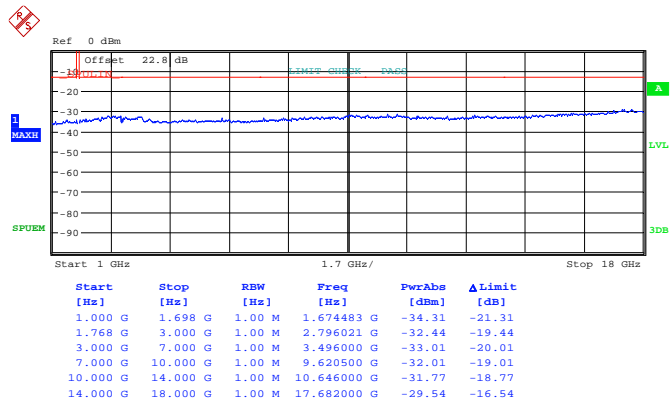

Date: 26.AUG.2013 10:28:02

Band :	LTE Band 4	Channel :	CH20300 (High)
Band Width :	20MHz		

QPSK (RB Size 1, RB Offset 49)

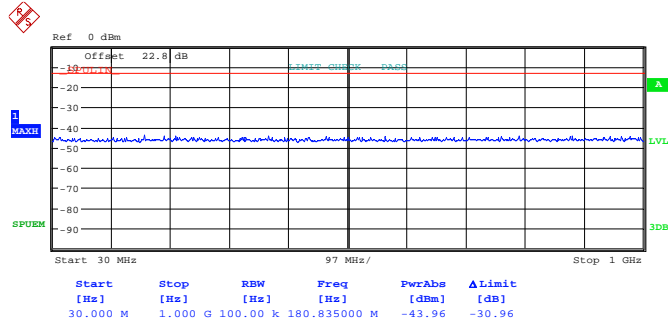

Date: 26.AUG.2013 10:32:19

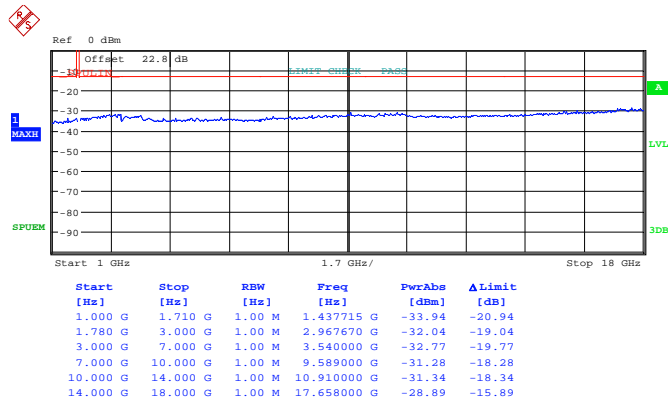

Date: 26.AUG.2013 10:31:39

16QAM (RB Size 1, RB Offset 49)

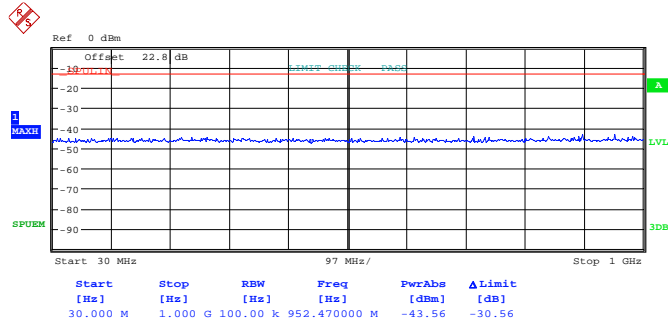

Date: 26.AUG.2013 10:32:07

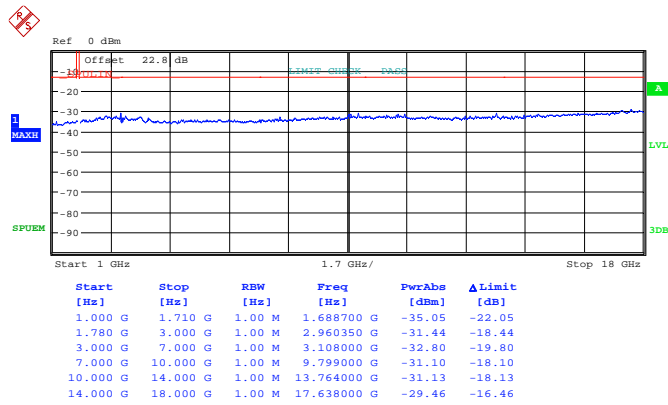

Date: 26.AUG.2013 10:31:52

Band :	LTE Band 13	Channel :	CH23205 (Low)
Band Width :	5MHz		

QPSK (RB Size 12, RB Offset 11)

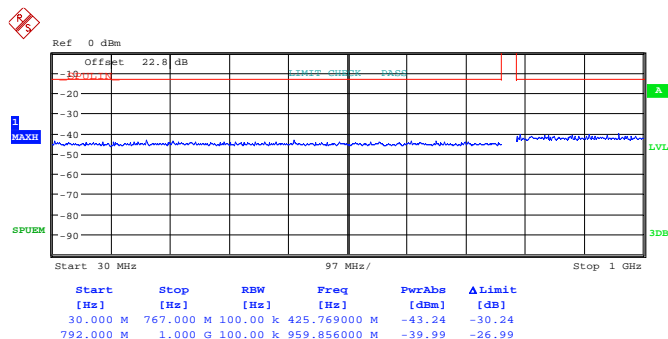

Date: 26.AUG.2013 10:46:26

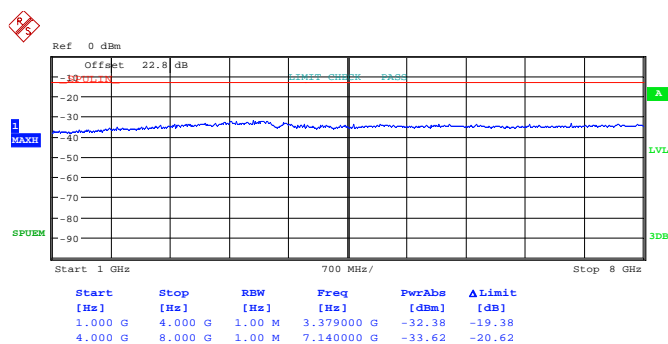

Date: 26.AUG.2013 10:47:10

16QAM (RB Size 1, RB Offset 24)

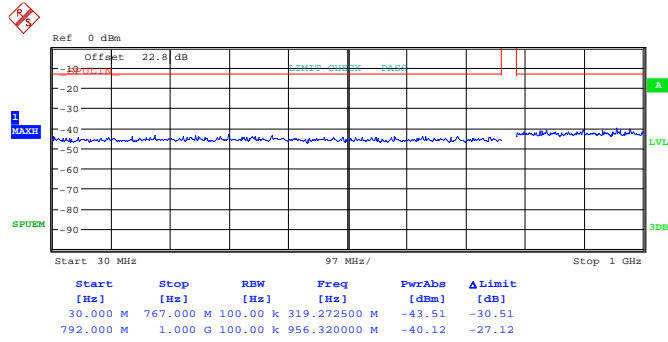

Date: 26.AUG.2013 10:46:39

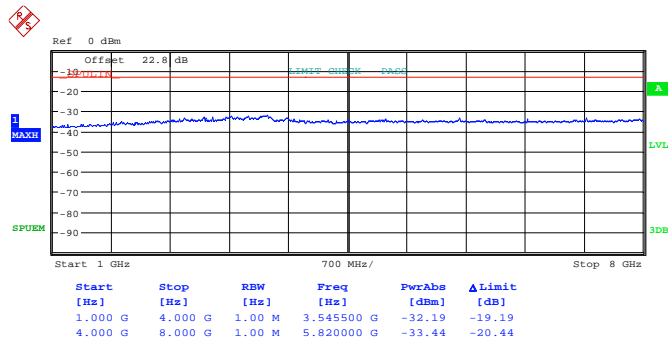

Date: 26.AUG.2013 10:46:53

Band :	LTE Band 13	Channel :	CH20230 (Middle)
Band Width :	5MHz		

QPSK (RB Size 1, RB Offset 24)

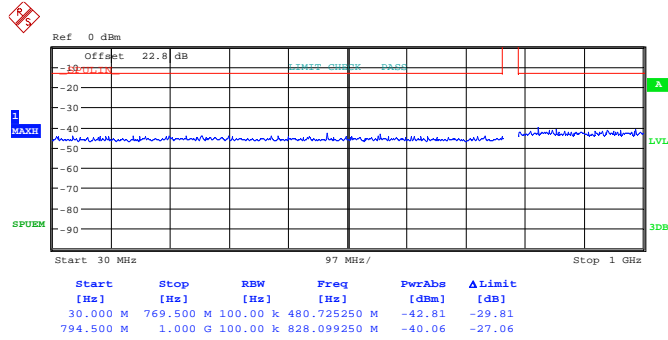

Date: 26.AUG.2013 10:45:22

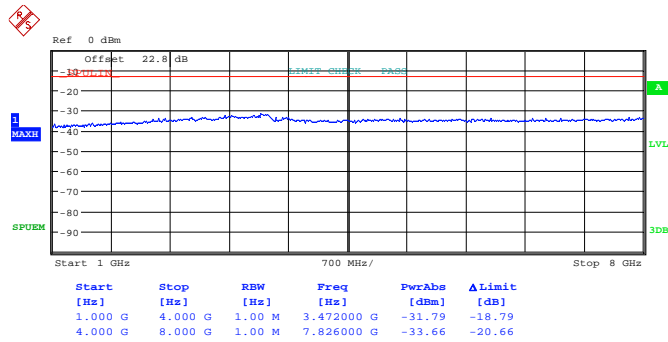

Date: 26.AUG.2013 10:44:44

16QAM (RB Size 1, RB Offset 24)

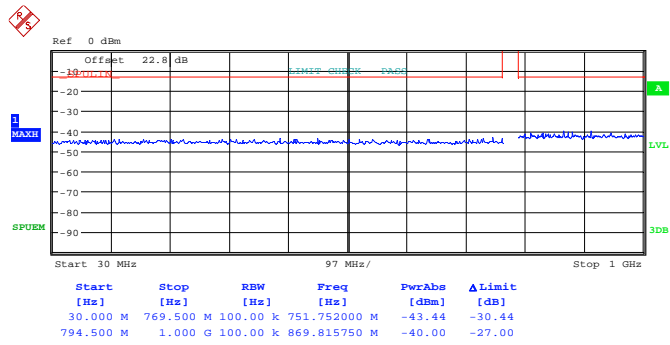

Date: 26.AUG.2013 10:45:11

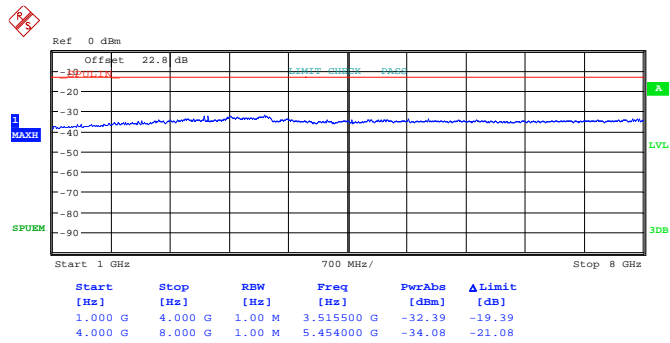

Date: 26.AUG.2013 10:44:56

Band :	LTE Band 13	Channel :	CH23255 (High)
Band Width :	5MHz		

QPSK (RB Size 1, RB Offset 12)

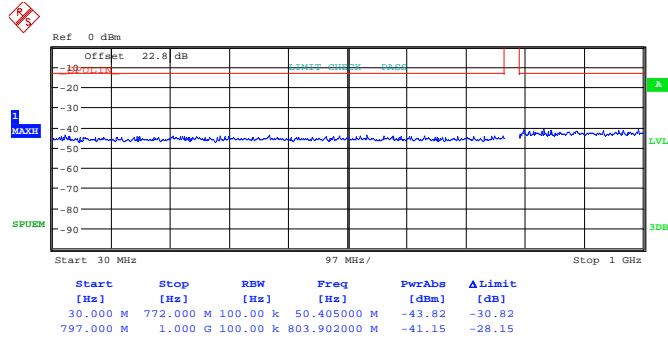

Date: 26.AUG.2013 10:49:42

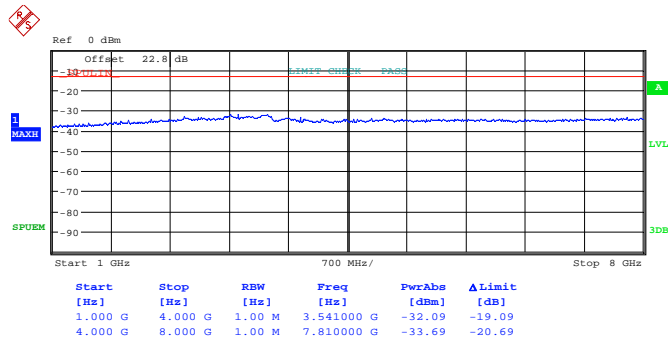

Date: 26.AUG.2013 10:49:04

16QAM (RB Size 1, RB Offset 12)

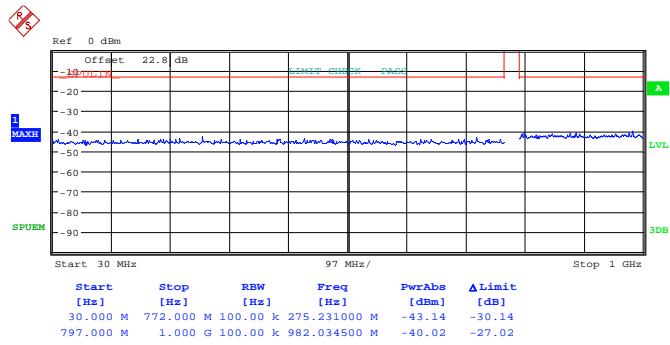

Date: 26.AUG.2013 10:49:31

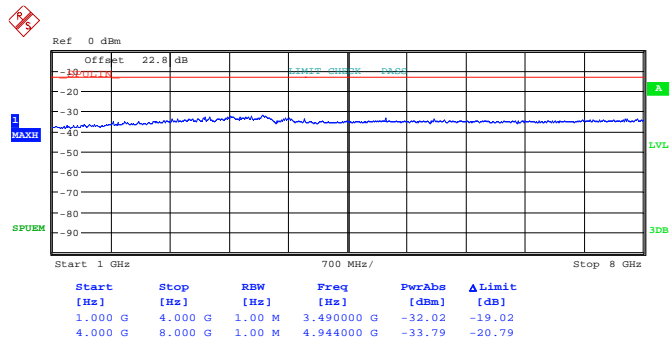

Date: 26.AUG.2013 10:49:16

Band :	LTE Band 13	Channel :	CH23230 (Middle)
Band Width :	10MHz		

QPSK (RB Size 1, RB Offset 49)

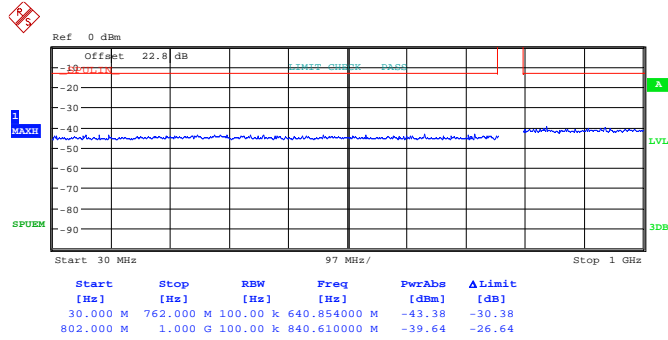

Date: 26.AUG.2013 10:42:18

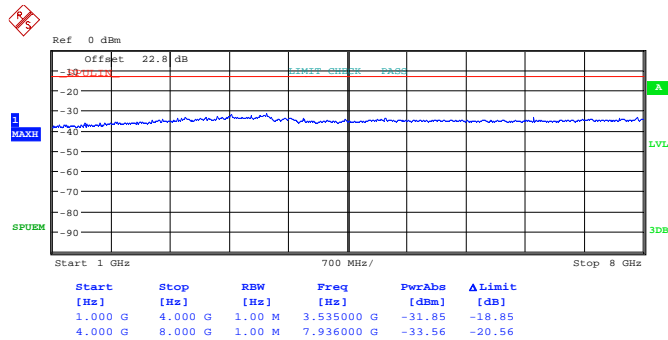

Date: 26.AUG.2013 10:43:00

16QAM (RB Size 1, RB Offset 49)

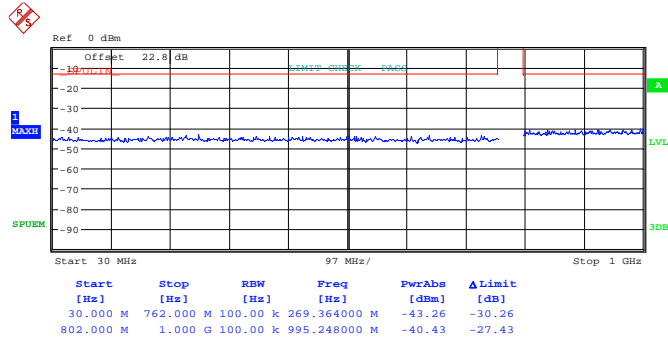

Date: 26.AUG.2013 10:42:32

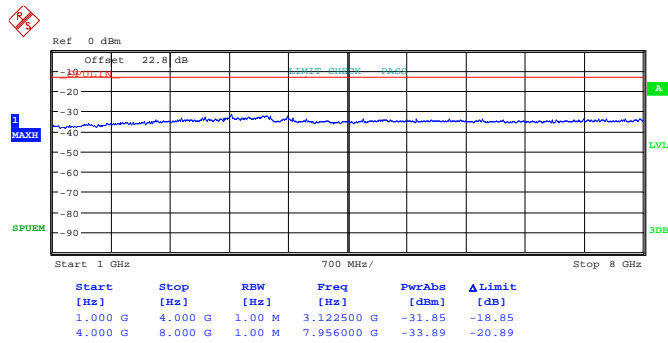

Date: 26.AUG.2013 10:42:47

3.6 Radiated Spurious Emission Measurement

3.6.1 Description of Radiated Spurious Emission

The radiated spurious emission was measured by substitution method according to ANSI / TIA / EIA-603-C-2004. The power of any emission outside of the authorized operating frequency ranges must be attenuated below the transmitter power (P) by a factor of at least $43 + 10 \log (P)$ dB. The spectrum is scanned from 30 MHz up to a frequency including its 10th harmonic.

3.6.2 Measuring Instruments

Measuring equipment is listed in the section 4 of this test report.

3.6.3 Test Procedures

1. The EUT was placed on a rotatable wooden table with 0.8 meter about ground.
2. The EUT was set 3 meters from the receiving antenna, which was mounted on the antenna tower.
3. The table was rotated 360 degrees to determine the position of the highest spurious emission.
4. The height of the receiving antenna is varied between one meter and four meters to search the maximum spurious emission for both horizontal and vertical polarizations.
5. Make the measurement with the spectrum analyzer's RBW = 1MHz, VBW = 3MHz, Sweep = 500ms, Taking the record of maximum spurious emission.
6. A horn antenna was substituted in place of the EUT and was driven by a signal generator.
7. Tune the output power of signal generator to the same emission level with EUT maximum spurious emission.
8. Taking the record of output power at antenna port.
9. Repeat step 7 to step 8 for another polarization.
10. The RF fundamental frequency should be excluded against the limit line in the operating frequency band.

The limit line is derived from $43 + 10\log(P)$ dB below the transmitter power P(Watts)
= $P(W) - [43 + 10\log(P)]$ (dB)
= $[30 + 10\log(P)]$ (dBm) - $[43 + 10\log(P)]$ (dB)
= -13dBm.

11. EIRP (dBm) = S.G. Power – Tx Cable Loss + Tx Antenna Gain
12. ERP (dBm) = EIRP - 2.15

3.6.4 Test Setup

For radiated emissions from 30MHz to 1GHz

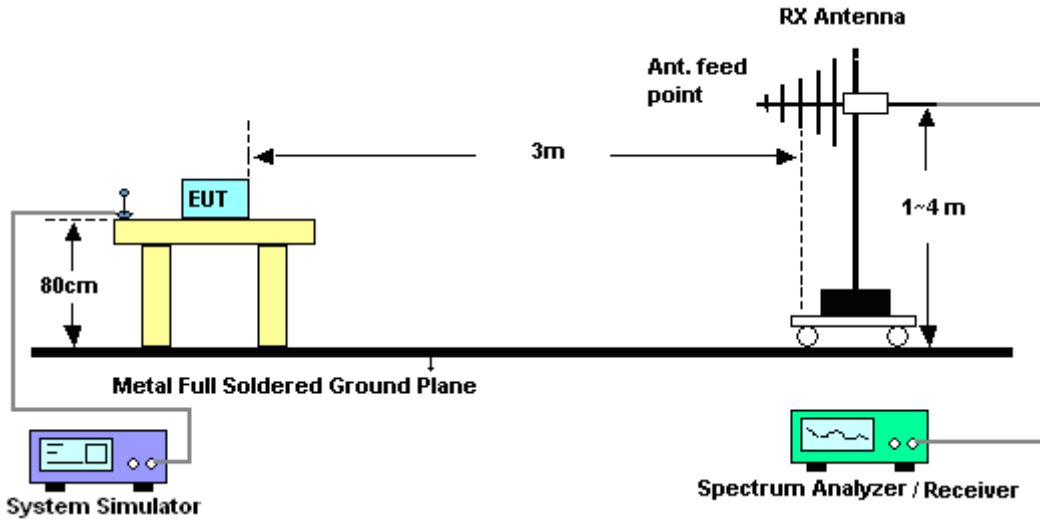

For radiated emissions above 1GHz

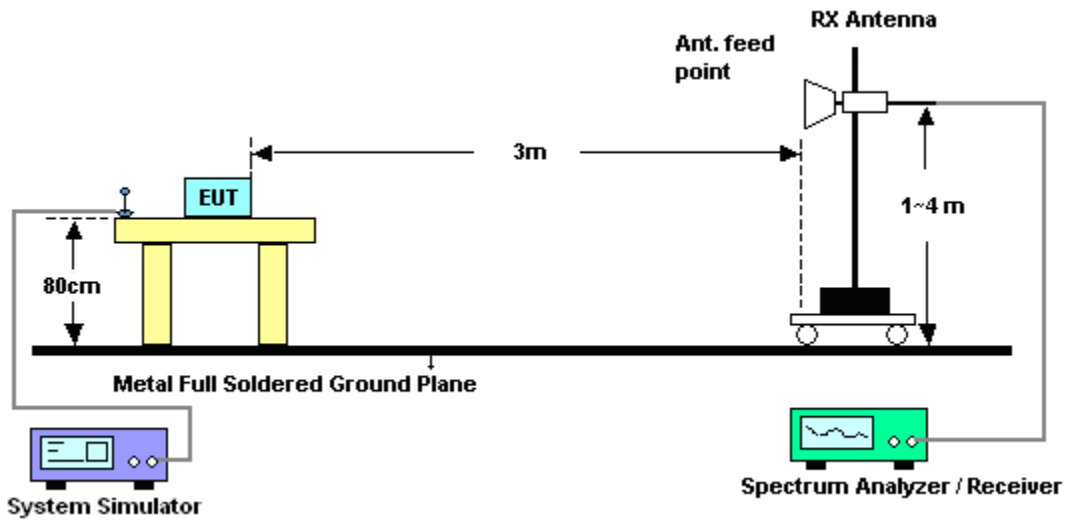

3.6.5 Test Result of Field Strength of Spurious Radiated

Band :	LTE Band 4	Temperature :	22~24°C
Test Mode :	1.4MHz QPSK RB Size 1 Offset 0	Relative Humidity :	51~53%
Test Engineer :	Ken Wu	Polarization :	Horizontal
Remark :	Spurious emissions within 30-10th harmonic were found more than 20dB below limit line.		

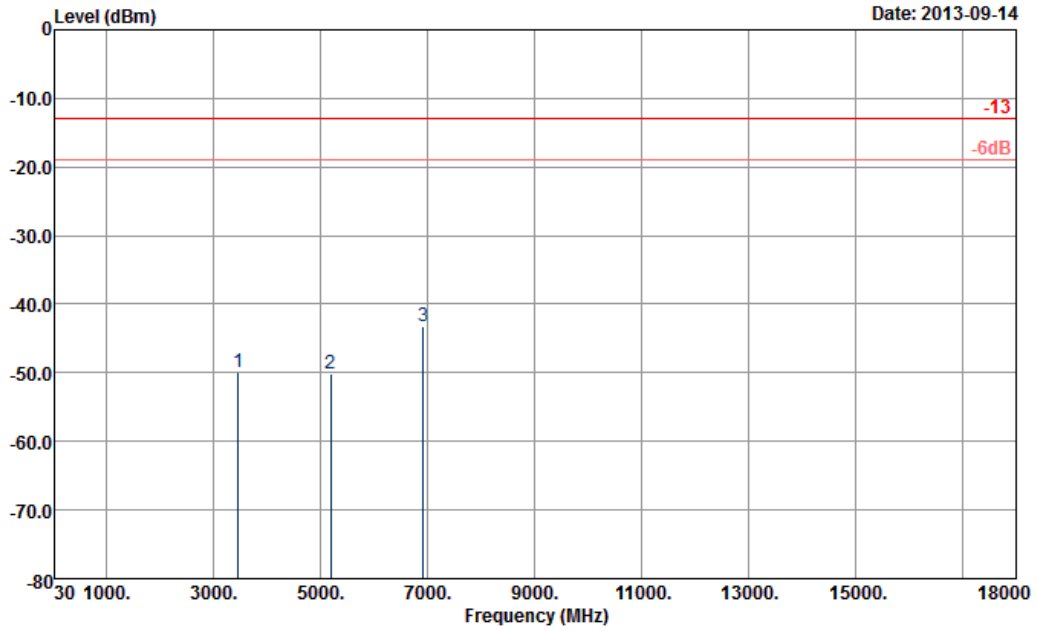

Site : 03CH07-HY
 Condition : -13 HF-EIRP(080306) HORIZONTAL

Frequency (MHz)	EIRP (dBm)	Limit (dBm)	Over Limit (dB)	SPA Reading (dBm)	S.G. Power (dBm)	TX Cable loss (dB)	TX Antenna Gain (dBi)	Polarization (H/V)	Result
3464	-49.92	-13	-36.92	-64.27	-51.6	4.48	8.31	H	Pass
5196	-50.21	-13	-37.21	-69.09	-52.7	5.332	9.98	H	Pass
6928	-43.31	-13	-30.31	-69.58	-46.4	6.1	11.34	H	Pass

Band :	LTE Band 4	Temperature :	22~24°C
Test Mode :	1.4MHz QPSK RB Size 1 Offset 0	Relative Humidity :	51~53%
Test Engineer :	Ken Wu	Polarization :	Vertical
Remark :	Spurious emissions within 30-10th harmonic were found more than 20dB below limit line.		

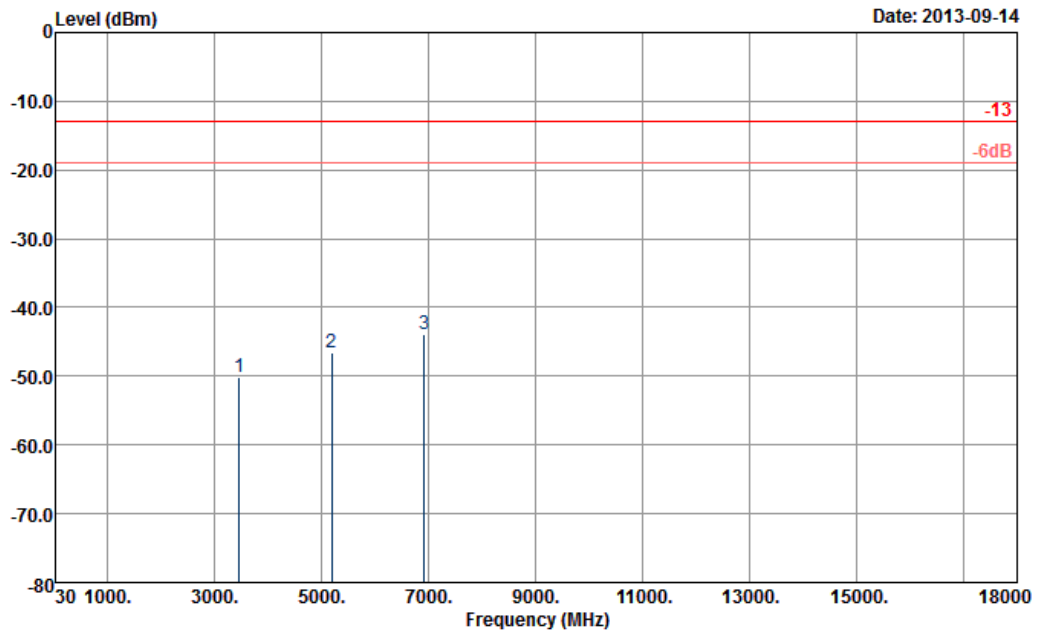

Site : 03CH07-HY
Condition : -13 HF-EIRP(080306) VERTICAL

Frequency (MHz)	EIRP (dBm)	Limit (dBm)	Over Limit (dB)	SPA Reading (dBm)	S.G. Power (dBm)	TX Cable loss (dB)	TX Antenna Gain (dBi)	Polarization (H/V)	Result
3464	-50.12	-13	-37.12	-65.6	-51.8	4.48	8.31	V	Pass
5196	-46.61	-13	-33.61	-65.49	-49.1	5.332	9.98	V	Pass
6928	-44.01	-13	-31.01	-69.34	-47.1	6.1	11.34	V	Pass

Band :	LTE Band 4	Temperature :	22~24°C
Test Mode :	3MHz QPSK RB Size 1 Offset 0	Relative Humidity :	51~53%
Test Engineer :	Ken Wu	Polarization :	Horizontal
Remark :	Spurious emissions within 30-10th harmonic were found more than 20dB below limit line.		

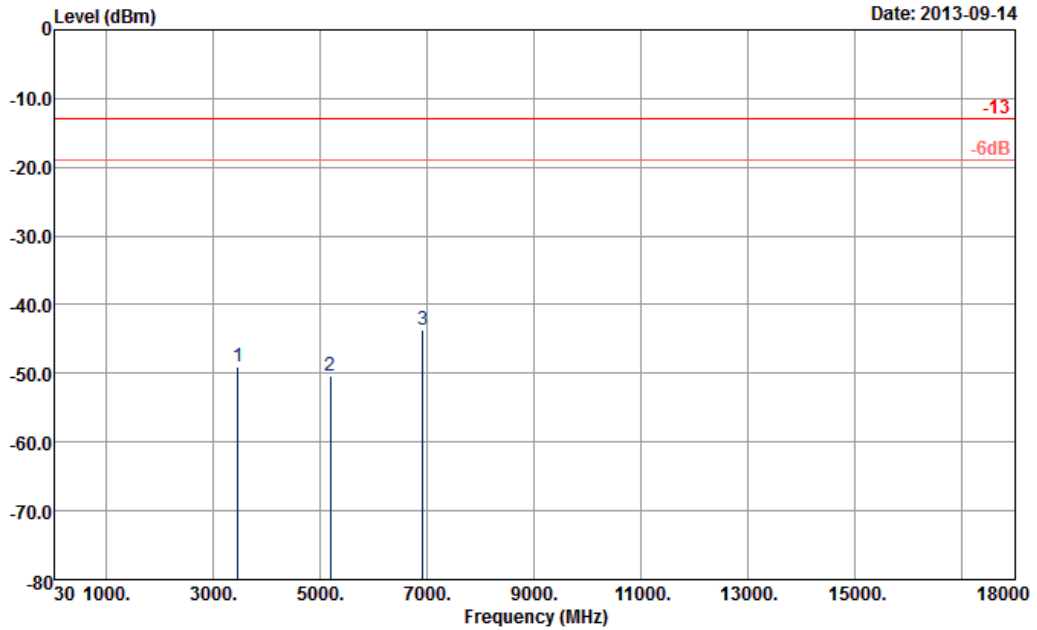

Site : 03CH07-HY
Condition : -13 HF-FIRP(080306) HORIZONTAL

Frequency (MHz)	EIRP (dBm)	Limit (dBm)	Over Limit (dB)	SPA Reading (dBm)	S.G. Power (dBm)	TX Cable loss (dB)	TX Antenna Gain (dBi)	Polarization (H/V)	Result
3460	-49.12	-13	-36.12	-63.51	-50.8	4.48	8.31	H	Pass
5190	-50.41	-13	-37.41	-69.35	-52.9	5.332	9.98	H	Pass
6920	-43.61	-13	-30.61	-69.93	-46.7	6.1	11.34	H	Pass

Band :	LTE Band 4	Temperature :	22~24°C
Test Mode :	3MHz QPSK RB Size 1 Offset 0	Relative Humidity :	51~53%
Test Engineer :	Ken Wu	Polarization :	Vertical
Remark :	Spurious emissions within 30-10th harmonic were found more than 20dB below limit line.		

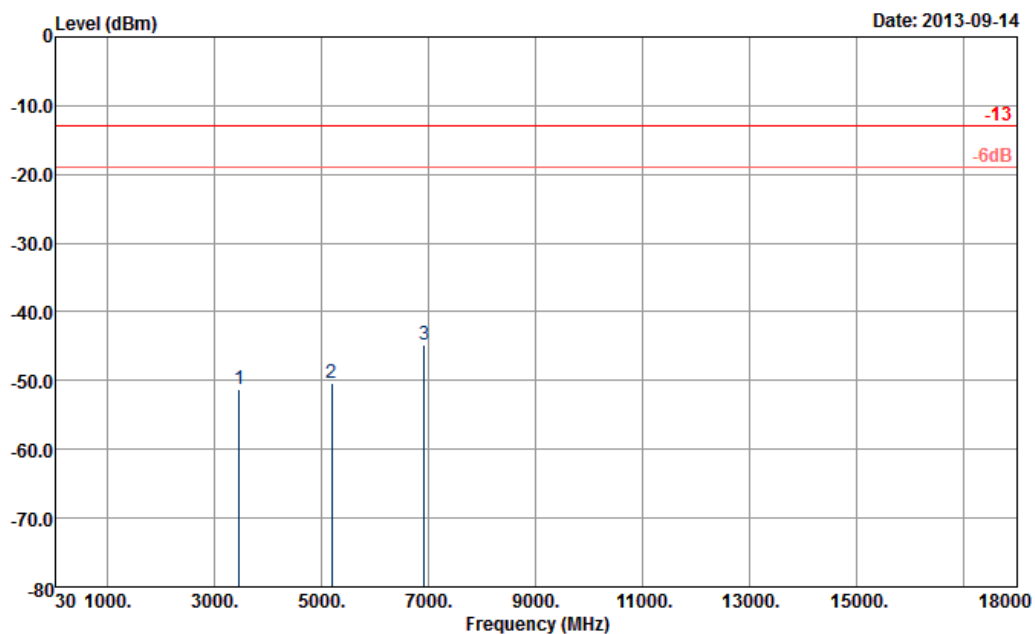

Site : 03CH07-HY
Condition : -13 HF-EIRP(080306) VERTICAL

Frequency (MHz)	EIRP (dBm)	Limit (dBm)	Over Limit (dB)	SPA Reading (dBm)	S.G. Power (dBm)	TX Cable loss (dB)	TX Antenna Gain (dBi)	Polarization (H/V)	Result
3460	-51.22	-13	-38.22	-66.98	-52.9	4.48	8.31	V	Pass
5190	-50.31	-13	-37.31	-68.87	-52.8	5.332	9.98	V	Pass
6920	-44.71	-13	-31.71	-70.14	-47.8	6.1	11.34	V	Pass

Band :	LTE Band 4	Temperature :	22~24°C
Test Mode :	5MHz, QPSK RB Size 1 Offset 0	Relative Humidity :	51~53%
Test Engineer :	Ken Wu	Polarization :	Horizontal
Remark :	Spurious emissions within 30-1000MHz were found more than 20dB below limit line.		

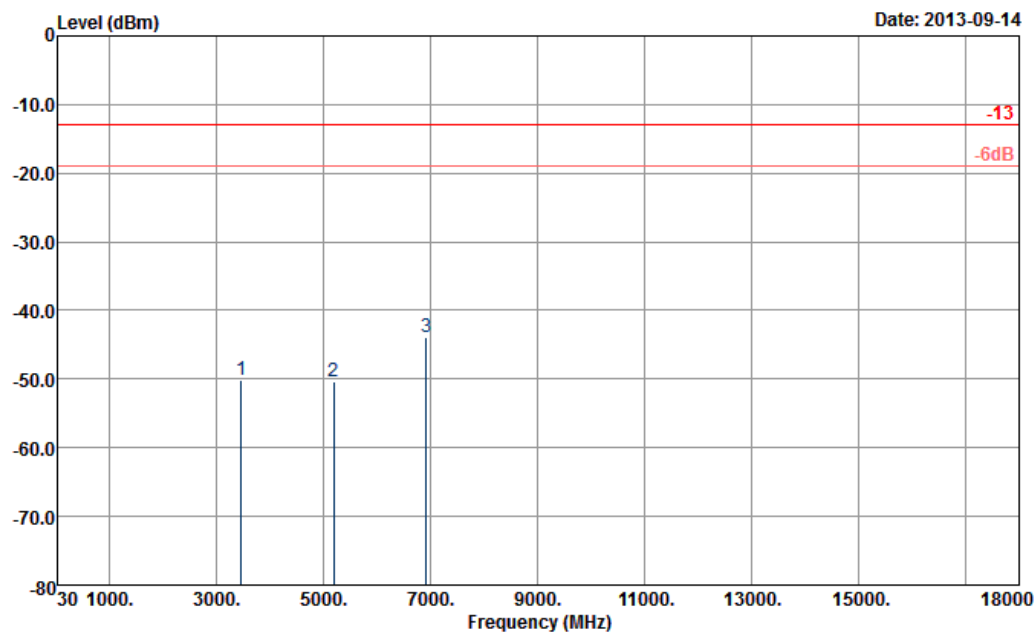

Site : 03CH07-HY
Condition : -13 HF-EIRP(080306) HORIZONTAL

Frequency (MHz)	EIRP (dBm)	Limit (dBm)	Over Limit (dB)	SPA Reading (dBm)	S.G. Power (dBm)	TX Cable loss (dB)	TX Antenna Gain (dBi)	Polarization (H/V)	Result
3460	-50.22	-13	-37.22	-64.45	-51.9	4.48	8.31	H	Pass
5190	-50.41	-13	-37.41	-69.33	-52.9	5.332	9.98	H	Pass
6920	-44.01	-13	-31.01	-70.08	-47.1	6.1	11.34	H	Pass

Band :	LTE Band 4	Temperature :	22~24°C
Test Mode :	5MHz, QPSK RB Size 1 Offset 0	Relative Humidity :	51~53%
Test Engineer :	Ken Wu	Polarization :	Vertical
Remark :	Spurious emissions within 30-1000MHz were found more than 20dB below limit line.		

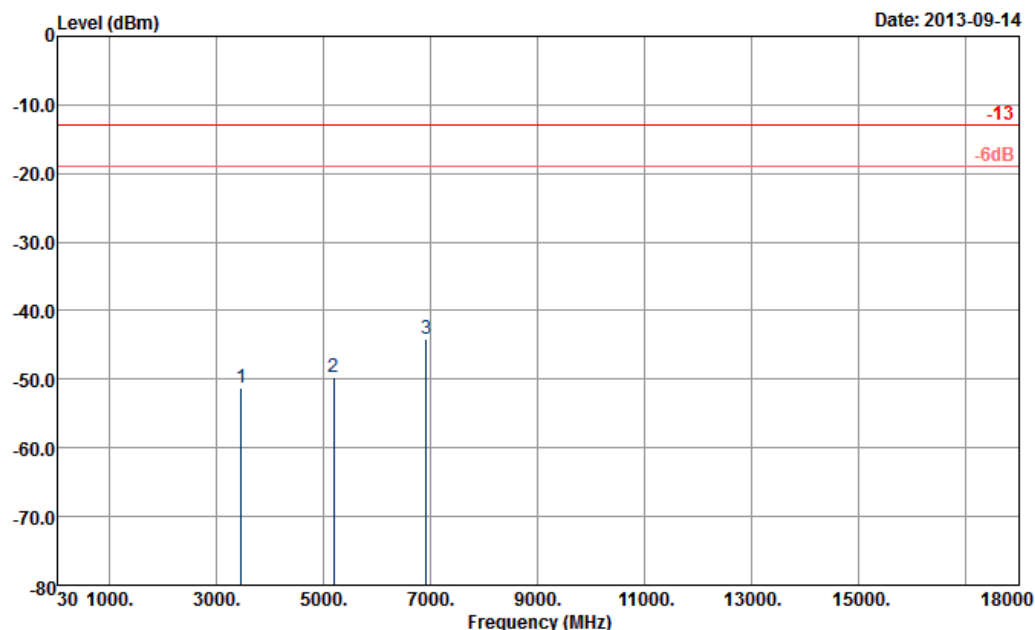

Site : 03CH07-HY
Condition : -13 HF-EIRP(080306) VERTICAL

Frequency (MHz)	EIRP (dBm)	Limit (dBm)	Over Limit (dB)	SPA Reading (dBm)	S.G. Power (dBm)	TX Cable loss (dB)	TX Antenna Gain (dBi)	Polarization (H/V)	Result
3460	-51.32	-13	-38.32	-66.84	-53	4.48	8.31	V	Pass
5190	-49.61	-13	-36.61	-68.67	-52.1	5.332	9.98	V	Pass
6920	-44.11	-13	-31.11	-69.48	-47.2	6.1	11.34	V	Pass

Band :	LTE Band 4	Temperature :	22~24°C
Test Mode :	10MHz, QPSK RB Size 1 Offset 0	Relative Humidity :	51~53%
Test Engineer :	Ken Wu	Polarization :	Horizontal
Remark :	Spurious emissions within 30-1000MHz were found more than 20dB below limit line.		

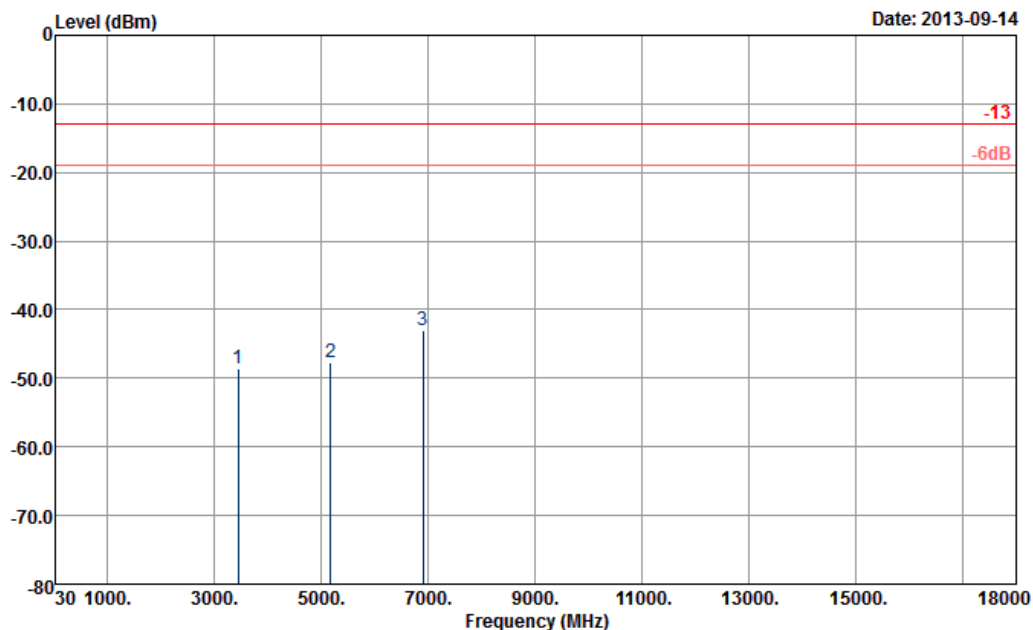

Site : 03CH07-HY
Condition : -13 HF-EIRP(080306) HORIZONTAL

Frequency (MHz)	EIRP (dBm)	Limit (dBm)	Over Limit (dB)	SPA Reading (dBm)	S.G. Power (dBm)	TX Cable loss (dB)	TX Antenna Gain (dBi)	Polarization (H/V)	Result
3456	-48.62	-13	-35.62	-63.26	-50.3	4.48	8.31	H	Pass
5184	-47.61	-13	-34.61	-66.63	-50.1	5.332	9.98	H	Pass
6912	-43.11	-13	-30.11	-69.15	-46.2	6.1	11.34	H	Pass

Band :	LTE Band 4	Temperature :	22~24°C
Test Mode :	10MHz, QPSK RB Size 1 Offset 0	Relative Humidity :	51~53%
Test Engineer :	Ken Wu	Polarization :	Vertical
Remark :	Spurious emissions within 30-1000MHz were found more than 20dB below limit line.		

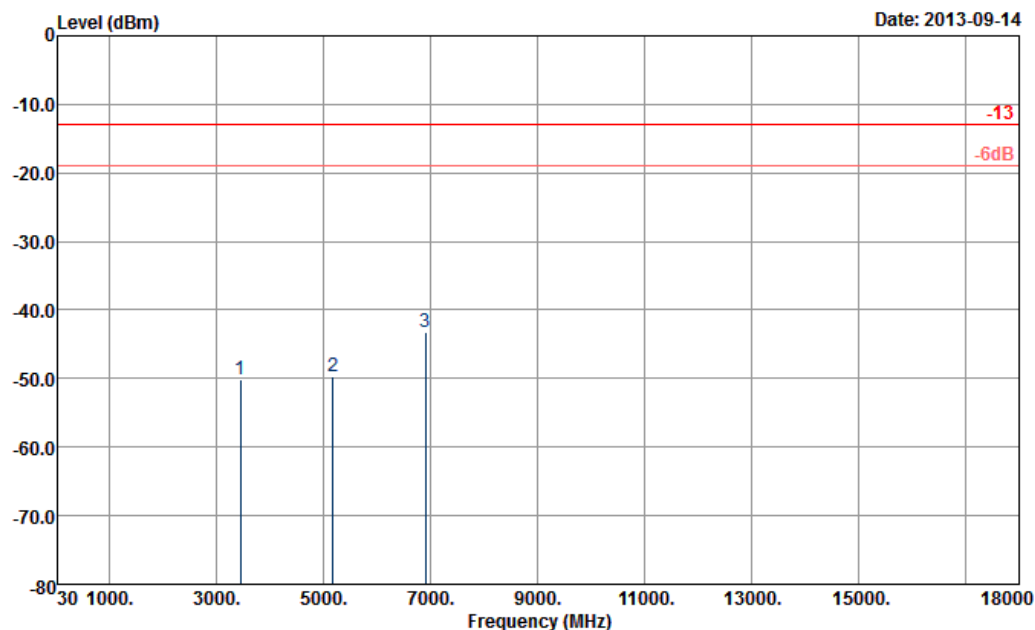

Site : 03CH07-HY
Condition : -13 HF-EIRP(080306) VERTICAL

Frequency (MHz)	EIRP (dBm)	Limit (dBm)	Over Limit (dB)	SPA Reading (dBm)	S.G. Power (dBm)	TX Cable loss (dB)	TX Antenna Gain (dBi)	Polarization (H/V)	Result
3456	-50.22	-13	-37.22	-66	-51.9	4.48	8.31	V	Pass
5184	-49.61	-13	-36.61	-68.6	-52.1	5.332	9.98	V	Pass
6912	-43.31	-13	-30.31	-68.8	-46.4	6.1	11.34	V	Pass

Band :	LTE Band 4	Temperature :	22~24°C
Test Mode :	15MHz, QPSK RB Size 1 Offset 0	Relative Humidity :	51~53%
Test Engineer :	Ken Wu	Polarization :	Horizontal
Remark :	Spurious emissions within 30-1000MHz were found more than 20dB below limit line.		

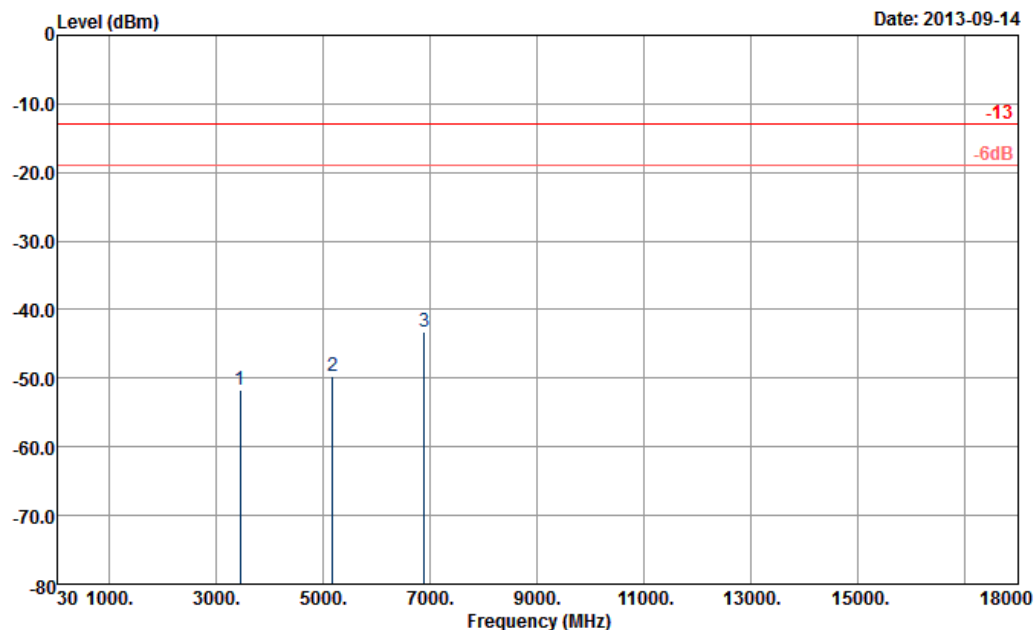

Site : 03CH07-HY
Condition : -13 HF-EIRP(080306) HORIZONTAL

Frequency (MHz)	EIRP (dBm)	Limit (dBm)	Over Limit (dB)	SPA Reading (dBm)	S.G. Power (dBm)	TX Cable loss (dB)	TX Antenna Gain (dBi)	Polarization (H/V)	Result
3450	-51.62	-13	-38.62	-66.08	-53.3	4.48	8.31	H	Pass
5175	-49.61	-13	-36.61	-68.52	-52.1	5.332	9.98	H	Pass
6900	-43.31	-13	-30.31	-69.45	-46.4	6.1	11.34	H	Pass

Band :	LTE Band 4	Temperature :	22~24°C
Test Mode :	15MHz, QPSK RB Size 1 Offset 0	Relative Humidity :	51~53%
Test Engineer :	Ken Wu	Polarization :	Vertical
Remark :	Spurious emissions within 30-1000MHz were found more than 20dB below limit line.		

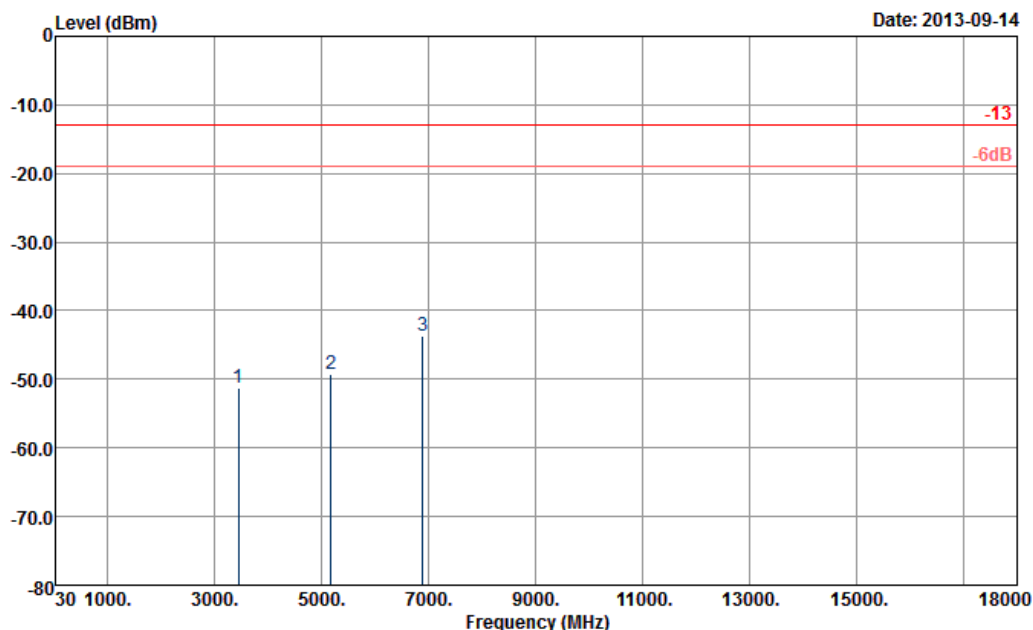

Site : 03CH07-HY
Condition : -13 HF-EIRP(080306) VERTICAL

Frequency (MHz)	EIRP (dBm)	Limit (dBm)	Over Limit (dB)	SPA Reading (dBm)	S.G. Power (dBm)	TX Cable loss (dB)	TX Antenna Gain (dBi)	Polarization (H/V)	Result
3450	-51.22	-13	-38.22	-66.94	-52.9	4.48	8.31	V	Pass
5175	-49.31	-13	-36.31	-68.26	-51.8	5.332	9.98	V	Pass
6900	-43.61	-13	-30.61	-68.71	-46.7	6.1	11.34	V	Pass

Band :	LTE Band 4	Temperature :	22~24°C
Test Mode :	20MHz, QPSK RB Size 1 Offset 0	Relative Humidity :	51~53%
Test Engineer :	Ken Wu	Polarization :	Horizontal
Remark :	Spurious emissions within 30-1000MHz were found more than 20dB below limit line.		

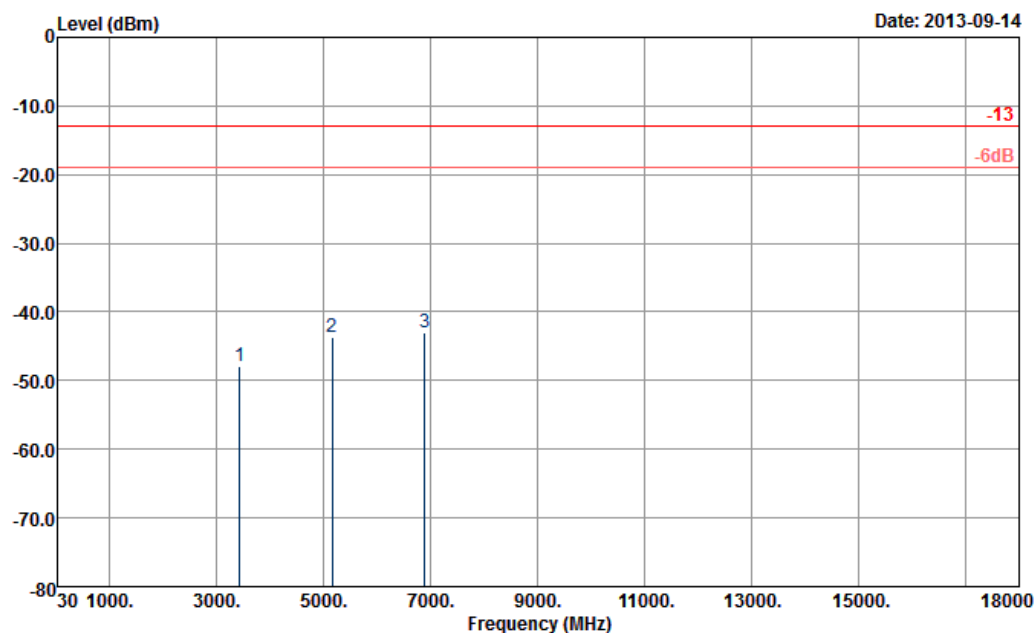

Site : 03CH07-HY
Condition : -13 HF-EIRP(080306) HORIZONTAL

Frequency (MHz)	EIRP (dBm)	Limit (dBm)	Over Limit (dB)	SPA Reading (dBm)	S.G. Power (dBm)	TX Cable loss (dB)	TX Antenna Gain (dBi)	Polarization (H/V)	Result
3444	-47.92	-13	-34.92	-62.24	-49.6	4.48	8.31	H	Pass
5172	-43.61	-13	-30.61	-62.46	-46.1	5.332	9.98	H	Pass
6888	-43.01	-13	-30.01	-69.05	-46.1	6.1	11.34	H	Pass

Band :	LTE Band 4	Temperature :	22~24°C
Test Mode :	20MHz, QPSK RB Size 1 Offset 0	Relative Humidity :	51~53%
Test Engineer :	Ken Wu	Polarization :	Vertical
Remark :	Spurious emissions within 30-1000MHz were found more than 20dB below limit line.		

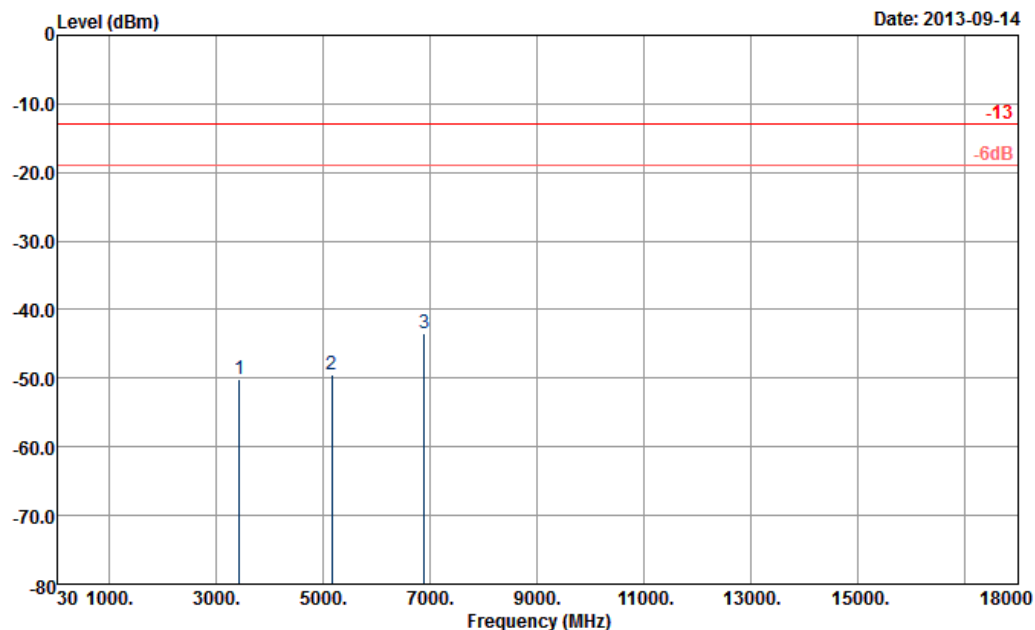

Site : 03CH07-HY
Condition : -13 HF-EIRP(080306) VERTICAL

Frequency (MHz)	EIRP (dBm)	Limit (dBm)	Over Limit (dB)	SPA Reading (dBm)	S.G. Power (dBm)	TX Cable loss (dB)	TX Antenna Gain (dBi)	Polarization (H/V)	Result
3444	-50.22	-13	-37.22	-65.9	-51.9	4.48	8.31	V	Pass
5172	-49.41	-13	-36.41	-68.33	-51.9	5.332	9.98	V	Pass
6888	-43.41	-13	-30.41	-68.78	-46.5	6.1	11.34	V	Pass

Band :	LTE Band 13	Temperature :	22~24°C
Test Mode :	5MHz, QPSK RB Size 1 Offset 0	Relative Humidity :	51~53%
Test Engineer :	Ken Wu	Polarization :	Horizontal
Remark :	Spurious emissions within 30-1000MHz were found more than 20dB below limit line.		

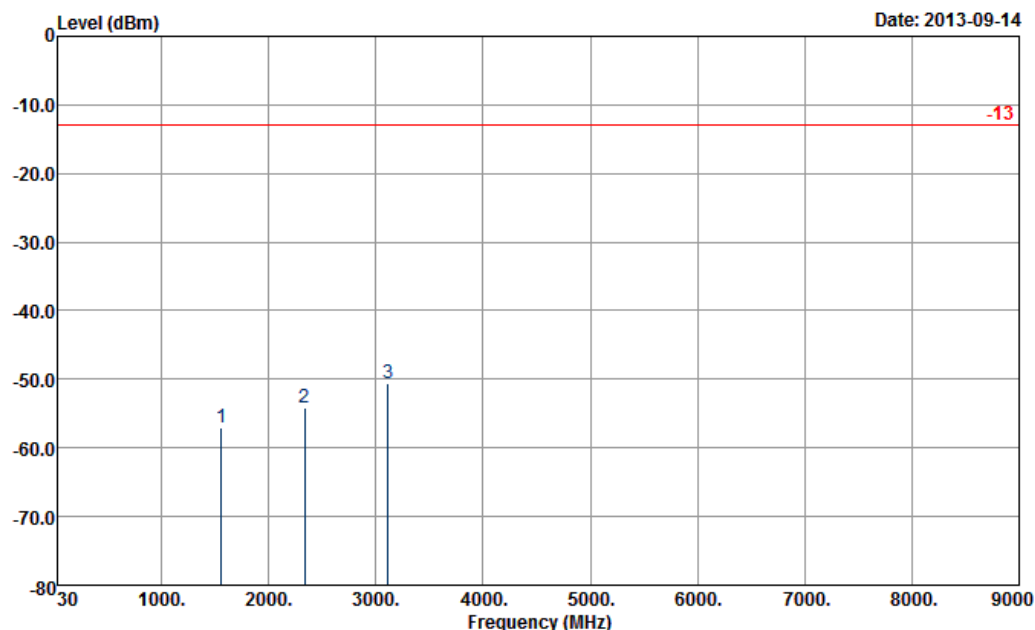

Site : 03CH07-HY
Condition : -13 HF-EIRP(080306) HORIZONTAL

Frequency (MHz)	ERP (dBm)	Limit (dBm)	Over Limit (dB)	SPA Reading (dBm)	S.G. Power (dBm)	TX Cable loss (dB)	TX Antenna Gain (dBi)	Polarization (H/V)	Result
1558	-56.97	-13	-43.97	-65.35	-58.8	1.51	5.49	H	1558
2337	-54.18	-13	-41.18	-66.72	-56.1	1.98	6.05	H	2337
3116	-50.58	-13	-37.58	-64.86	-53.6	2.39	7.56	H	3116

Band :	LTE Band 13	Temperature :	22~24°C
Test Mode :	5MHz, QPSK RB Size 1 Offset 0	Relative Humidity :	51~53%
Test Engineer :	Ken Wu	Polarization :	Vertical
Remark :	Spurious emissions within 30-1000MHz were found more than 20dB below limit line.		

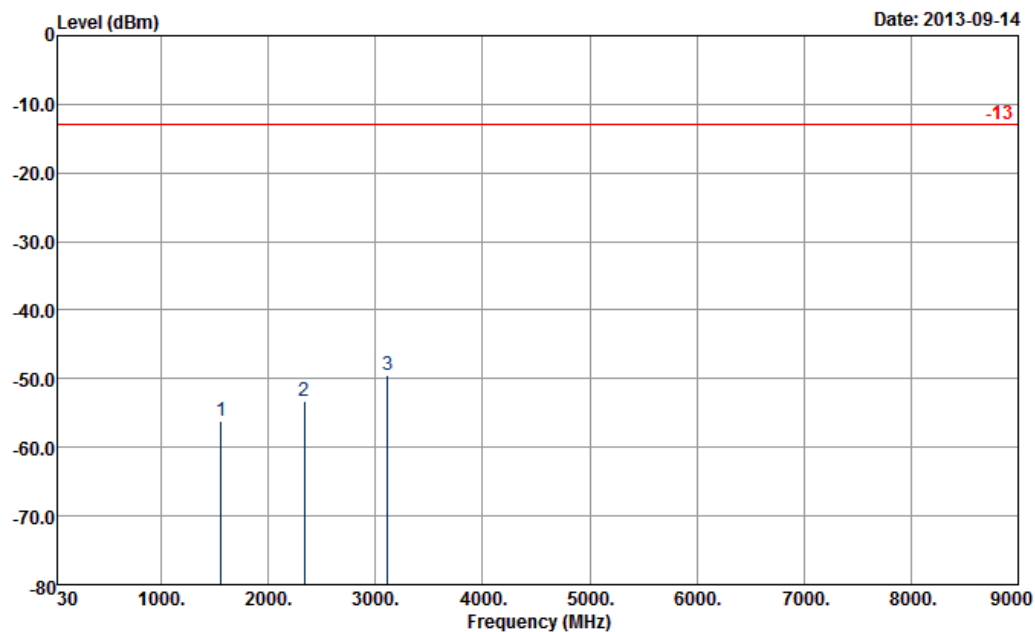

Site : 03CH07-HY
Condition : -13 HF-EIRP(080306) VERTICAL

Frequency (MHz)	ERP (dBm)	Limit (dBm)	Over Limit (dB)	SPA Reading (dBm)	S.G. Power (dBm)	TX Cable loss (dB)	TX Antenna Gain (dBi)	Polarization (H/V)	Result
1558	-56.17	-13	-43.17	-66.64	-58	1.51	5.49	V	Pass
2337	-53.18	-13	-40.18	-66.65	-55.1	1.98	6.05	V	Pass
3116	-49.38	-13	-36.38	-65.03	-52.4	2.39	7.56	V	Pass

Band :	LTE Band 13	Temperature :	22~24°C
Test Mode :	10MHz, QPSK RB Size 1 Offset 0	Relative Humidity :	51~53%
Test Engineer :	Ken Wu	Polarization :	Horizontal
Remark :	Spurious emissions within 30-1000MHz were found more than 20dB below limit line.		

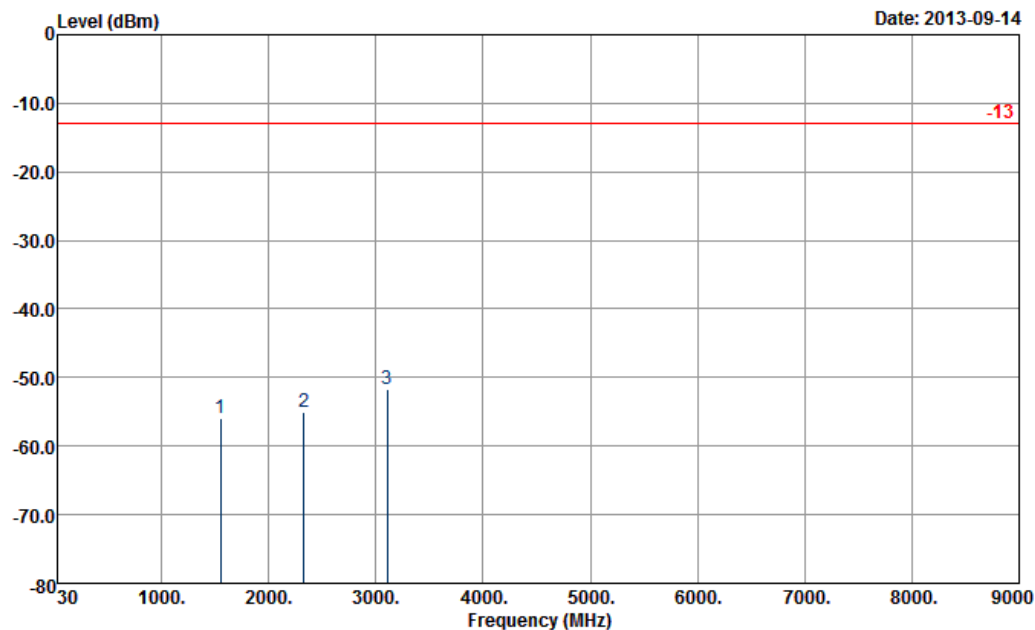

Site : 03CH07-HY
Condition : -13 HF-EIRP(080306) HORIZONTAL

Frequency (MHz)	ERP (dBm)	Limit (dBm)	Over Limit (dB)	SPA Reading (dBm)	S.G. Power (dBm)	TX Cable loss (dB)	TX Antenna Gain (dBi)	Polarization (H/V)	Result
1554	-55.87	-13	-42.87	-64.28	-57.7	1.51	5.49	H	Pass
2331	-54.98	-13	-41.98	-67.49	-56.9	1.98	6.05	H	Pass
3108	-51.78	-13	-38.78	-65.62	-54.8	2.39	7.56	H	Pass

Band :	LTE Band 13	Temperature :	22~24°C
Test Mode :	10MHz, QPSK RB Size 1 Offset 0	Relative Humidity :	51~53%
Test Engineer :	Ken Wu	Polarization :	Vertical
Remark :	Spurious emissions within 30-1000MHz were found more than 20dB below limit line.		

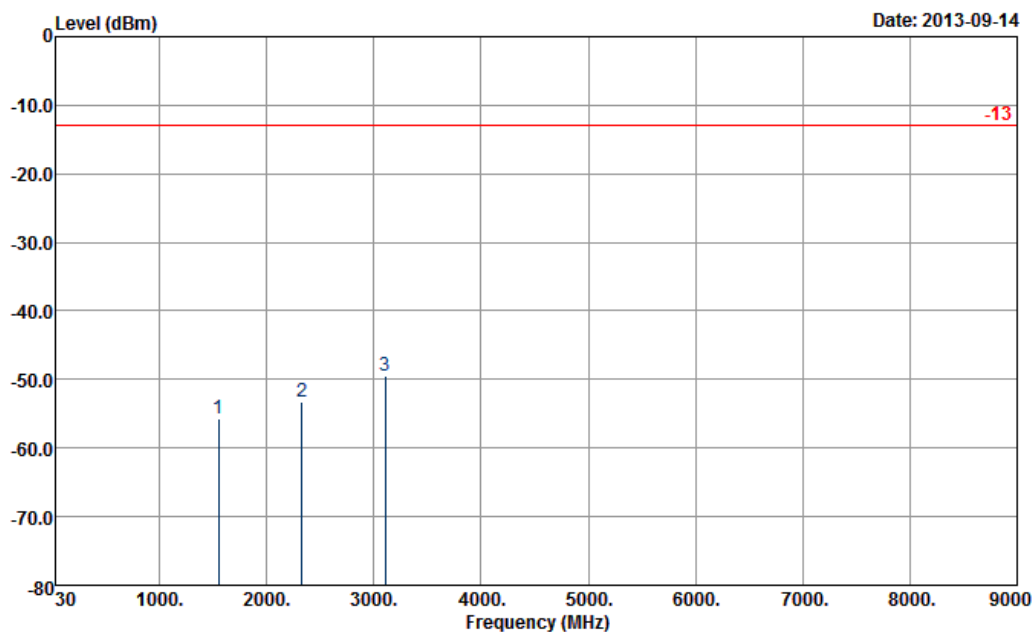

Site : 03CH07-HY
Condition : -13 HF-EIRP(080306) VERTICAL

Frequency (MHz)	ERP (dBm)	Limit (dBm)	Over Limit (dB)	SPA Reading (dBm)	S.G. Power (dBm)	TX Cable loss (dB)	TX Antenna Gain (dBi)	Polarization (H/V)	Result
1554	-55.67	-13	-42.67	-66.39	-57.5	1.51	5.49	V	Pass
2331	-53.28	-13	-40.28	-66.75	-55.2	1.98	6.05	V	Pass
3108	-49.58	-13	-36.58	-65.59	-52.6	2.39	7.56	V	Pass

3.7 Frequency Stability Measurement

3.7.1 Description of Frequency Stability Measurement

The frequency stability shall be measured by variation of ambient temperature and variation of primary supply voltage to ensure that the fundamental emission stays within the authorized frequency block. The frequency stability of the transmitter shall be maintained within $\pm 0.00025\%$ ($\pm 2.5\text{ppm}$) of the center frequency.

3.7.2 Measuring Instruments

Measuring equipment is listed in the section 4 of this test report.

3.7.3 Test Procedures for Temperature Variation

1. The EUT was set up in the thermal chamber and connected with the base station.
2. With power OFF, the temperature was decreased to -30°C and the EUT was stabilized before testing. Power was applied and the maximum change in frequency was recorded within one minute.
3. With power OFF, the temperature was raised in 10°C step up to 50°C . The EUT was stabilized at each step for at least half an hour. Power was applied and the maximum frequency change was recorded within one minute.

3.7.4 Test Procedures for Voltage Variation

1. The EUT was placed in a temperature chamber at $25\pm 5^{\circ}\text{C}$ and connected with the base station.
2. The power supply voltage to the EUT was varied from 85% to 115% of the nominal value measured at the input to the EUT.
3. The variation in frequency was measured for the worst case.

3.7.5 Test Setup

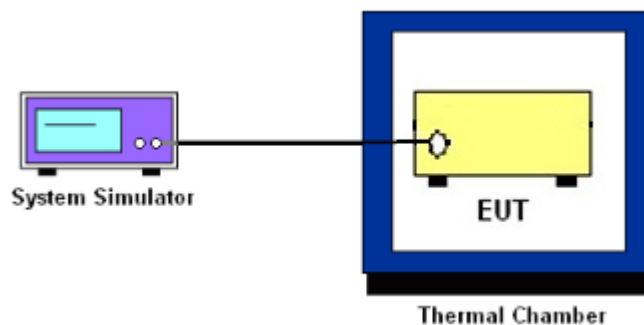

3.7.6 Test Result of Temperature Variation

Band :	LTE Band 4 (QPSK)		Limit (ppm) :	2.5	
Temperature (°C)	BW 1.4MHz		BW 3MHz		Result
	Freq. Dev. (Hz)	Deviation (ppm)	Freq. Dev. (Hz)	Deviation (ppm)	
-30	8.6	0.005	7.6	0.004	PASS
-20	6.8	0.004	-6.4	-0.004	
-10	-7.2	-0.004	5.8	0.003	
0	5.9	0.003	-7.1	-0.004	
10	6.1	0.004	6.4	0.004	
20	-5.2	-0.003	6.1	0.004	
30	-6.0	-0.003	5.9	0.003	
40	4.9	0.003	4.6	0.003	
50	7.1	0.004	7.5	0.004	

Band :	LTE Band 4 (QPSK)		Limit (ppm) :	2.5	
Temperature (°C)	BW 5MHz		BW 10MHz		Result
	Freq. Dev. (Hz)	Deviation (ppm)	Freq. Dev. (Hz)	Deviation (ppm)	
-30	6.4	0.004	-7.3	-0.004	PASS
-20	-5.7	-0.003	6.2	0.004	
-10	6.9	0.004	4.9	0.003	
0	5.3	0.003	-6.8	-0.004	
10	4.7	0.003	4.3	0.002	
20	5.1	0.003	6.1	0.004	
30	6.5	0.004	5.5	0.003	
40	-7.2	-0.004	5.7	0.003	
50	6.8	0.004	-6.1	-0.004	

Band :	LTE Band 4 (QPSK)	Limit (ppm) :	2.5
---------------	-------------------	----------------------	-----

Temperature (°C)	BW 15MHz		BW 20MHz		Result
	Freq. Dev. (Hz)	Deviation (ppm)	Freq. Dev. (Hz)	Deviation (ppm)	
-30	-5.7	-0.003	5.9	0.003	PASS
-20	6.1	0.004	5.2	0.003	
-10	-4.8	-0.003	-7.1	-0.004	
0	6.3	0.004	4.8	0.003	
10	5.2	0.003	4.5	0.003	
20	4.5	0.003	-4.9	-0.003	
30	6.0	0.003	5.3	0.003	
40	6.4	0.004	6.1	0.004	
50	-7.1	-0.004	-6.0	-0.003	

Band :	LTE Band 4 (16QAM)	Limit (ppm) :	2.5
---------------	--------------------	----------------------	-----

Temperature (°C)	BW 1.4MHz		BW 3MHz		Result
	Freq. Dev. (Hz)	Deviation (ppm)	Freq. Dev. (Hz)	Deviation (ppm)	
-30	5.9	0.003	-6.8	-0.004	PASS
-20	-7.8	-0.005	5.2	0.003	
-10	-6.5	-0.004	4.9	0.003	
0	7.0	0.004	6.3	0.004	
10	-6.3	-0.004	4.5	0.003	
20	5.7	0.003	-5.1	-0.003	
30	5.2	0.003	4.2	0.002	
40	6.3	0.004	6.9	0.004	
50	-6.4	-0.004	-5.8	-0.003	

Band :	LTE Band 4 (16QAM)	Limit (ppm) :	2.5
---------------	--------------------	----------------------	-----

Temperature (°C)	BW 5MHz		BW 10MHz		Result
	Freq. Dev. (Hz)	Deviation (ppm)	Freq. Dev. (Hz)	Deviation (ppm)	
-30	7.1	0.004	6.3	0.004	PASS
-20	6.2	0.004	-7.2	-0.004	
-10	-8.0	-0.005	6.9	0.004	
0	5.6	0.003	5.7	0.003	
10	6.1	0.004	6.1	0.004	
20	5.4	0.003	-5.2	-0.003	
30	-6.1	-0.004	-6.0	-0.003	
40	5.7	0.003	-5.4	-0.003	
50	-7.0	-0.004	6.7	0.004	

Band :	LTE Band 4 (16QAM)	Limit (ppm) :	2.5
---------------	--------------------	----------------------	-----

Temperature (°C)	BW 15MHz		BW 20MHz		Result
	Freq. Dev. (Hz)	Deviation (ppm)	Freq. Dev. (Hz)	Deviation (ppm)	
-30	7.9	0.005	5.6	0.003	PASS
-20	-6.4	-0.004	6.7	0.004	
-10	6.8	0.004	-6.4	-0.004	
0	-5.2	-0.003	5.9	0.003	
10	4.9	0.003	-4.8	-0.003	
20	-4.7	-0.003	6.0	0.003	
30	5.1	0.003	5.2	0.003	
40	-6.1	-0.004	-4.1	-0.002	
50	-7.2	-0.004	-6.3	-0.004	

Band :	LTE Band 13 (QPSK)	Limit (ppm) :	2.5
---------------	--------------------	----------------------	-----

Temperature (°C)	BW 5MHz		BW 10MHz		Result
	Freq. Dev. (Hz)	Deviation (ppm)	Freq. Dev. (Hz)	Deviation (ppm)	
-30	7.2	0.009	-5.8	-0.007	PASS
-20	-6.7	-0.009	6.1	0.008	
-10	-5.9	-0.008	5.0	0.006	
0	6.2	0.008	-4.8	-0.006	
10	5.1	0.007	5.3	0.007	
20	4.3	0.005	-7.1	-0.009	
30	-4.8	-0.006	5.5	0.007	
40	5.4	0.007	5.1	0.007	
50	5.9	0.008	6.4	0.008	

Band :	LTE Band 13 (16QAM)	Limit (ppm) :	2.5
---------------	---------------------	----------------------	-----

Temperature (°C)	BW 5MHz		BW 10MHz		Result
	Freq. Dev. (Hz)	Deviation (ppm)	Freq. Dev. (Hz)	Deviation (ppm)	
-30	4.8	0.006	7.1	0.009	PASS
-20	5.1	0.007	-5.8	-0.007	
-10	-6.0	-0.008	-6.3	-0.008	
0	4.7	0.006	5.6	0.007	
10	5.2	0.007	-4.8	-0.006	
20	-4.3	-0.005	4.2	0.005	
30	-4.9	-0.006	4.5	0.006	
40	-5.1	-0.007	-6.1	-0.008	
50	6.2	0.008	-5.0	-0.006	

3.7.7 Test Result of Voltage Variation

Band	Bandwidth	Voltage (Volt)	Freq. Dev. (Hz)	Deviation (ppm)	Limit (ppm)	Result
LTE Band 4 (QPSK)	1.4M	4.2	4.2	0.002	2.5	PASS
		Normal	6.7	0.004		
		3.4	-5.6	-0.003		
	3M	4.2	-6.2	-0.004		
		Normal	7.1	0.004		
		3.4	3.9	0.002		
	5M	4.2	4.3	0.002		
		Normal	-4.8	-0.003		
		3.4	-6.3	-0.004		
	10M	4.2	5.8	0.003		
		Normal	-6.4	-0.004		
		3.4	-6.0	-0.003		
	15M	4.2	7.2	0.004		
		Normal	-6.1	-0.004		
		3.4	-5.4	-0.003		
20M	4.2	6.3	0.004			
	Normal	-7.5	-0.004			
	3.4	-5.7	-0.003			
LTE Band 13 (QPSK)	5M	4.2	-7.9	-0.010	2.5	PASS
		Normal	6.4	0.008		
		3.4	-5.7	-0.007		
	10M	4.2	6.1	0.008		
		Normal	7.6	0.010		
		3.4	-4.8	-0.006		

Band	Bandwidth	Voltage (Volt)	Freq. Dev. (Hz)	Deviation (ppm)	Limit (ppm)	Result
LTE Band 4 (16QAM)	1.4M	4.2	7.2	0.004	2.5	PASS
		Normal	-3.9	-0.002		
		3.4	-4.3	-0.002		
	3M	4.2	6.1	0.004		
		Normal	-5.7	-0.003		
		3.4	6.3	0.004		
	5M	4.2	-4.6	-0.003		
		Normal	4.2	0.002		
		3.4	5.8	0.003		
	10M	4.2	-4.9	-0.003		
		Normal	5.2	0.003		
		3.4	6.0	0.003		
	15M	4.2	-4.8	-0.003		
		Normal	5.6	0.003		
		3.4	6.1	0.004		
20M	4.2	-4.1	-0.002			
	Normal	6.5	0.004			
	3.4	-4.7	-0.003			
LTE Band 13 (16QAM)	5M	4.2	4.9	0.006	2.5	PASS
		Normal	-4.8	-0.006		
		3.4	6.2	0.008		
	10M	4.2	5.7	0.007		
		Normal	-4.1	-0.005		
		3.4	3.9	0.005		

Remark:

1. Normal Voltage = 3.7V.
2. The manufacturer declared that the EUT could work properly between voltage 3.4V ~ 4.2V.

4 List of Measuring Equipment

Instrument	Manufacturer	Model No.	Serial No.	Characteristics	Calibration Date	Test Date	Due Date	Remark
Spectrum Analyzer	Rohde & Schwarz	FSP40	100055	9kHz~40GHz	Jun. 07, 2013	Jul. 29, 2013~ Aug. 26, 2013	Jun. 06, 2014	Conducted (TH02-HY)
Thermal Chamber	Ten Billion	TTH-D3SP	TBN-930701	N/A	Jul. 19, 2013	Jul. 29, 2013~ Aug. 26, 2013	Jul. 18, 2014	Conducted (TH02-HY)
LTE Base Station	Anritsu	MT8820C	6201026480	30MHz~2.7GHz SISO(FDD Band 1~26)	Jan. 04, 2013	Jul. 29, 2013~ Aug. 26, 2013	Jan. 03, 2014	Conducted (TH02-HY)
Spectrum Analyzer	Rohde & Schwarz	FSP30	101067	9KHz~30GHz	Nov. 30, 2012	Sep. 14, 2013	Nov. 29, 2013	Radiation (03CH07-HY)
Bilog Antenna	Schaffner	CBL6111C	2726	30MHz~1GHz	Oct. 06, 2012	Sep. 14, 2013	Oct. 05, 2013	Radiation (03CH07-HY)
Double Ridge Horn Antenna	ESCO	3117	75962	1GHz~18GHz	Aug. 22, 2013	Sep. 14, 2013	Aug. 21, 2014	Radiation (03CH07-HY)
Preamplifier	COM-POWER	PA-103A	161241	30MHz~1GHz	Feb. 26, 2013	Sep. 14, 2013	Feb. 25, 2014	Radiation (03CH07-HY)
Preamplifier	Agilent	8449B	3008A02362	1GHz~26.5GHz	Dec. 01, 2012	Sep. 14, 2013	Nov. 30, 2013	Radiation (03CH07-HY)
Turn Table	ChainTek	ChainTek 3000	N/A	0 ~ 360 degree	N/A	Sep. 14, 2013	N/A	Radiation (03CH07-HY)
Antenna Mast	ChainTek	ChainTek 3000	N/A	N/A	N/A	Sep. 14, 2013	N/A	Radiation (03CH07-HY)

5 Uncertainty of Evaluation

Uncertainty of Radiated Emission Measurement (30 MHz ~ 1000 MHz)

Measuring Uncertainty for a Level of Confidence of 95% ($U = 2Uc(y)$)	2.54
---	------

Uncertainty of Radiated Emission Measurement (1 GHz ~ 40 GHz)

Measuring Uncertainty for a Level of Confidence of 95% ($U = 2Uc(y)$)	4.72
---	------

SPORTON INTERNATIONAL INC.

TEL : 886-3-327-3456

FAX : 886-3-328-4978

FCC ID : S2F-6740

Page Number : A1 of A1

Report Issued Date : Oct. 10, 2013

Report Version : Rev. 02