

FCC PART 95

MEASUREMENT AND TEST REPORT

For

Guangzhou Walkera Technology Co., Ltd

Taishi Industrial Park, Yuwotou Town, Panyu District, Guangzhou, Guangdong, China

FCC ID: S29WK-0701

March 6, 2006

This Report Concerns: <input checked="" type="checkbox"/> Original Report	Equipment Type: Transmitter for R/C Helicopter
Test Engineer:	Tony Wu
Report Number:	SE06B-052R
Test Date:	Feb18~Feb28, 2006
Reviewed By:	<i>Tony Wu</i>
Prepared By:	S&E Technologies Laboratory Ltd Room407,Block A Shennan Garden,Hi-Tech Industrial Park, Shenzhen 518057, P.R. China . Tel: 86-755-26636573, 26630631 Fax: 86-755-26630557

Note: This test report is limited to the above client company and the product model only. It may not be duplicated without prior written consent of S&E Technologies Laboratory Ltd.

TABLE OF CONTENTS

1 - GENERAL INFORMATION.....	3
1.1 Product Description for Equipment Under Test (EUT).....	3
1.2 Test Standards.....	3
1.3 Test Summary.....	4
1.4 Test Methodology	4
1.5 Test Facility.....	5
1.6 Test Equipment List and Details	5
2 - SYSTEM TEST CONFIGURATION	6
2.1 Justification	6
2.2 EUT Exercise Software.....	6
2.3 Special Accessories.....	6
2.4 Equipment Modifications.....	6
2.5 Basic Test Setup Block Diagram	6
3 – CONDUCTED DISTURBANCES	7
3.1 Measurement Uncertainty.....	7
3.2 Limit of Conducted Disturbances (Class B)	7
3.3 Test Description	7
4- RF OUTPUT POWER	8
4.1 Standard Applicable.....	8
4.2 Test Procedure	8
4.3 RF Output Power Test Result.....	9
5- OCCUPIED BANDWIDTH	10
5.1 Standard Applicable.....	10
5.2 Test Procedure	10
5.3 Occupied Bandwidth Test Result.....	10
6- §95.635(B)(1), §95.635(B)(3), §95.635(B)(7), §95.635(B)(10), §95.635(B)(11), §95.635(B)(12) - UNWANTED EMISSION	12
6.1 Standard Applicable.....	12
6.2 Test Procedure	12
6.3 Unwanted Emission Test Result	13
7- FREQUENCY STABILITY MEASUREMENT	14
7.1 Standard Applicable.....	14
7.2 Test Procedure	14
7.3 Frequency Stability Test Result	14

1 - GENERAL INFORMATION

1.1 Product Description for Equipment Under Test (EUT)

Client Information

Applicant: **Guangzhou Walkera Technology Co., Ltd**
 Address of applicant: Taishi Industrial Park, Yuwotou Town, Panyu District, Guangzhou, Guangdong, China
 Manufacturer: **Guangzhou Walkera Technology Co., Ltd**
 Address of manufacturer: Taishi Industrial Park, Yuwotou Town, Panyu District, Guangzhou, Guangdong, China

General Description of E.U.T

The **Guangzhou Walkera Technology Co., Ltd.**'s product, model number: **WK-0701** or the "EUT" as referred to in this report is a transmitter of **Transmitter for R/C Helicopter**

The technical data has been listed following:

Items	Description
EUT Description:	Transmitter for R/C Helicopter
Trade Name:	Walkera
Model No.:	WK-0701
Rated Voltage:	DC 12V (8 X AA Size Rechargeable or Unrechargeable Battery) for Transmitter
Max. Output Power	0.020W (13dBm)
Frequency range:	72.81MHz
Number of channels:	6 digital channel with different digital code for identification
Size	180mmL x 95mmW x 185mmH
Channel Separation:	None
Type of Antenna:	Dedicate Antenna

** The test data gathered are from the production sample provided by the manufacturer.*

1.2 Test Standards

The following Declaration of Conformity report of EUT is prepared in accordance with

FCC Rules and Regulations Part 2

FCC Rules and Regulations Part 95 Subpart C

The objective of the manufacturer is to demonstrate compliance with the described above standards.

1.3 Test Summary

For the EUT described above, test items carried out Under FCC Rules and Regulations Part 2 & FCC Rules and Regulations Part 95 Subpart C are listed as follow:

FCC Rules	Test Item	Requirement	Result
2.1053 15.107 (a)	Conducted Emission	Reference to Conducted Limit Table in 15.107 (a)	Complied
2.1046 95.639 (b)(3)	RF Output Power	0.75W	Complied
2.1049 95.633 (b)	Emission Bandwidth	8 kHz	Complied
95.635(b)(1) 95.635(b)(3) 95.635(b)(7) 95.635(b)(10) 95.635(b)(11) 95.635(b)(12)	Unwanted Emission	Reference to section 6.3 in this report	Complied
2.1055 95.623	Frequency Stability Vs. Temperature Vs. Voltage	Deviation < 0.002%	Complied

1.4 Test Methodology

All measurements contained in this report were conducted with ANSI C63.4-2003.

The equipment under test (EUT) was configured to measure its highest possible radiation level. The test modes were adapted accordingly in reference to the Operating Instructions.

The maximum emission levels emanating from the device are compared to the FCC Rules and Regulations Part 95 Subpart C limits for radiation emissions and the measurement results contained in this test report show that EUT is to be technically compliant with FCC requirements.

All measurement required was performed at laboratory of Shenzhen Huatongwei International Inspection Co., Ltd at Keji Nan No.12 Road, Hi-tech Park, Shenzhen, China

1.5 Test Facility

The test facility is recognized, certified, or accredited by the following organizations:

FCC – Registration No.: 662850

Shenzhen Huatongwei International Inspection Co., Ltd, EMC Laboratory has been registered and fully described in a report filed with the (FCC) Federal Communications Commission. The acceptance letter from the FCC is maintained in our files. Registration 662850, November 17, 2003.

1.6 Test Equipment List and Details

Equipment	Manufacturer	Model No.	Serial No.	Last Cal	Calibration Period
EMI Test Receiver	ROHDE & SCHWARZ	ESCS30	100038	2005/11	1 year
EMI Test Receiver	ROHDE & SCHWARZ	ESI 26	100009	2005/11	1 year
Test Receiver/ spectrum analyzer	ROHDE & SCHWARZ	ESPI	100123	2005/03	1 year
Artificial Mains	ROHDE & SCHWARZ	ESH2-Z5	100028	2005/11	1 year
Pulse Limiter	ROHDE & SCHWARZ	ESHSZ2	100044	2005/11	1 year
Ultra-Broadband Antenna	ROHDE & SCHWARZ	HL562	100015	2005/11	1 year
Signal Generator	IFR	2023A	202304/060	2005/11	1 year
EMI Test Receiver	ROHDE & SCHWARZ	ESI 26	100009	2005/11	1 year
RF Test Panel	ROHDE & SCHWARZ	TS / RSP	335015/ 0017	N/A	N/A
Climate Chamber	QINGSHENG	THS-2001	ZHS-C7C	2005/11	1 year
Turntable	ETS	2088	2149	N/A	N/A
Antenna Mast	ETS	2075	2346	N/A	N/A

2 - SYSTEM TEST CONFIGURATION

2.1 Justification

The EUT was tested according to TIA/EIA 603A to represent the worst-case results during the final qualification test.

2.2 EUT Exercise Software

The EUT exercising program used during radiated and conducted testing was designed to exercise the various system components in a manner similar to a typical use. The software offered by manufacture, can let the EUT being normal operation.

2.3 Special Accessories

There are no special accessories necessary for compliance of this product supplied by **Guangzhou Walkera Technology Co., Ltd** and its respective support equipment manufacturers.

2.4 Equipment Modifications

The EUT tested was not modified by S&E.

2.5 Basic Test Setup Block Diagram

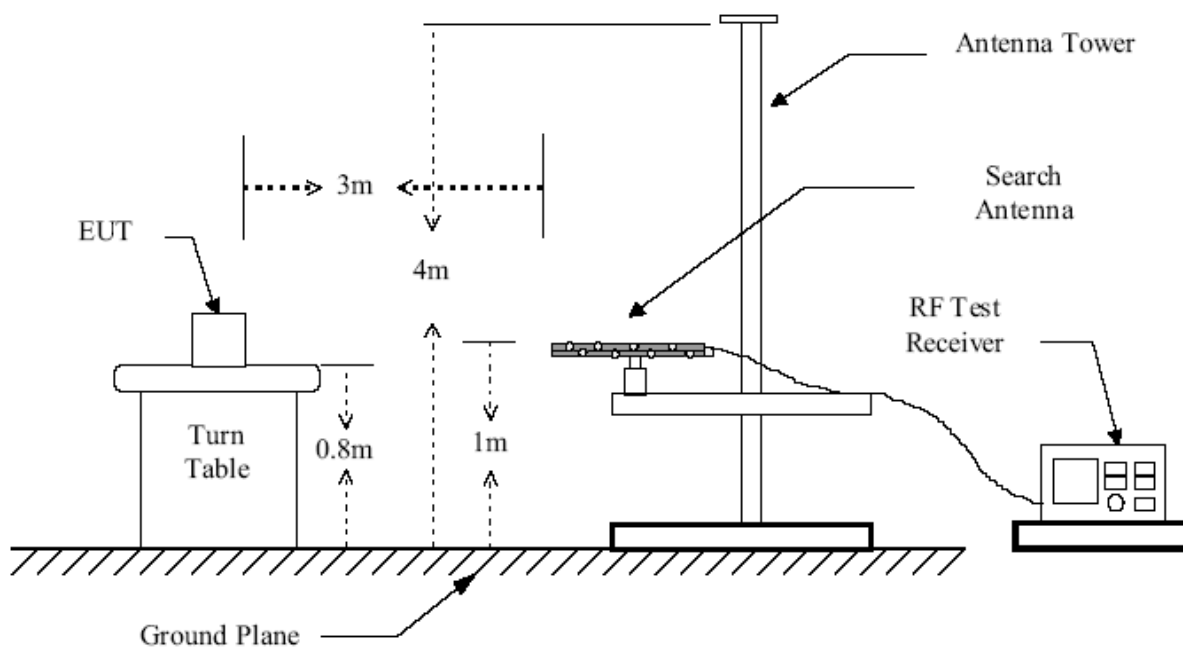

Figure 1 : Frequencies measured below 1 GHz configuration

3 – Conducted Disturbances

3.1 Measurement Uncertainty

All measurements involve certain levels of uncertainties, especially in field of EMC. The factors contributing to uncertainties are spectrum analyzer, cable loss, and LISN.

The Treatment of Uncertainty in EMC Measurements, the best estimate of the uncertainty of any conducted emissions measurement is ± 2.4 dB.

3.2 Limit of Conducted Disturbances (Class B)

Frequency Range (MHz)	Limits (dBuV)	
	Quasi-Peak	Average
0.150 ~ 0.500	66 ~ 56	56 ~ 46
0.500 ~ 5.000	56	46
5.000 ~ 30.00	60	50

Note: (1)The tighter limit shall apply at the edge between two frequency bands.

3.3 Test Description

The EUT is excused from investigation of Disturbance Voltage at The Mains Terminals, for it can be powered alternatively by rechargeable or unchargeable battery and the charger was not supplied by the applicant. According to the Section 15.207(d), measurement to demonstrate compliance with the limits of Disturbance Voltage at The Mains Terminals are not required to the devices which only employed battery power for operation and which do not operate from the AC power lines or contain provisions for operation while connected to the AC power lines.

4- RF OUTPUT POWER

4.1 Standard Applicable

Per FCC §2.1046, and §95.639(b)(3), No R/C transmitter, under any condition of modulation, shall exceed a carrier power or peak envelope TP (single-sideband only) of: 0.75 W in the 72-76 MHz frequency band.

4.2 Test Procedure

The technique used to find the output power of the transmitter was the antenna substitution method. The test procedure was followed:

1. The EUT was powered ON and placed on a table in the chamber. The antenna of the transmitter was extended to its maximum length of 117cm.
2. The fundamental frequency (72.810MHz) of the transmitter was maximized on the test receiver display by raising and lowering the receive antenna and by rotating the turntable. After the fundamental emission was maximized, a field strength measurement was made.
3. Steps 1 and 2 were preformed with the EUT and the receive antenna in both vertical and horizontal polarization and performed a pre-test three orthogonal planes.
4. The transmitter was then removed and replaced with a substitution antenna.
5. A signal at the fundamental frequency (72.810MHz) was fed to the substitution antenna by means of a non-radiating cable. With both the substitution and the receive antennas horizontally and vertically polarized, the receive antenna was raised and lowered to obtain a maximum reading at the test receiver. The level of the signal generator was adjusted until the measured field strength level in step 2 is obtained for this set of conditions.
6. The output power into the substitution antenna was then measured.

The test setup plot was followed:

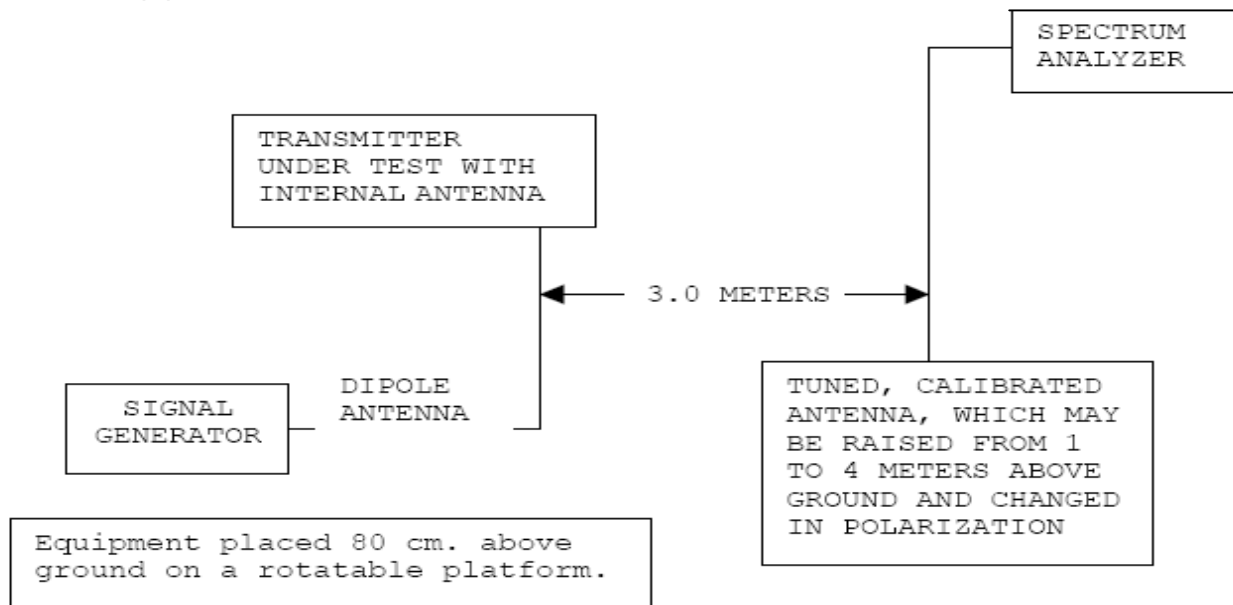

4.3 RF Output Power Test Result

Temperature ()	22~23
Humidity (%RH)	50~54
Barometric Pressure (mbar)	950~1000
EUT	Transmitter for R/C Helicopter
M/N	WK-0701
Operating Mode	Continuous Transmitting

Test result:

The transmitter output power found using the antenna substitution method was 0.017W.

Indicated		Table	Test Antenna			Substituted		Antenna Gain Correction	Cable Loss dB	Absolute Level dBm	Limit dBm	Margin dB
Frequency MHz	Meter Reading dBuV/m		Angle Degree	Height Meter	Polar H/V	Frequency MHz	Level dBm					
72.81	98.47	356	1.10	V	72.81	10.05	2.4	0.1	12.35	/	/	

5- OCCUPIED BANDWIDTH

5.1 Standard Applicable

Per FCC §2.1049 and FCC §95.633 (b), The authorized bandwidth for any emission type transmitted by an R/C transmitter is 8 kHz.

5.2 Test Procedure

The antenna was disconnected from the transmitter and the short cable was connected to the transmitter RF output. The RF output was connected to the input of the spectrum analyzer through sufficient attenuation.

Turn on the transmitter, and set it to transmit the pulse train continuously.

The bandwidth of the carrier was measured and recorded.

5.3 Occupied Bandwidth Test Result

Temperature ()	22~23
Humidity (%RH)	50~54
Barometric Pressure (mbar)	950~1000
EUT	Transmitter for R/C Helicopter
M/N	WK-0701
Operating Mode	Continuous Transmitting

Test plots see following page

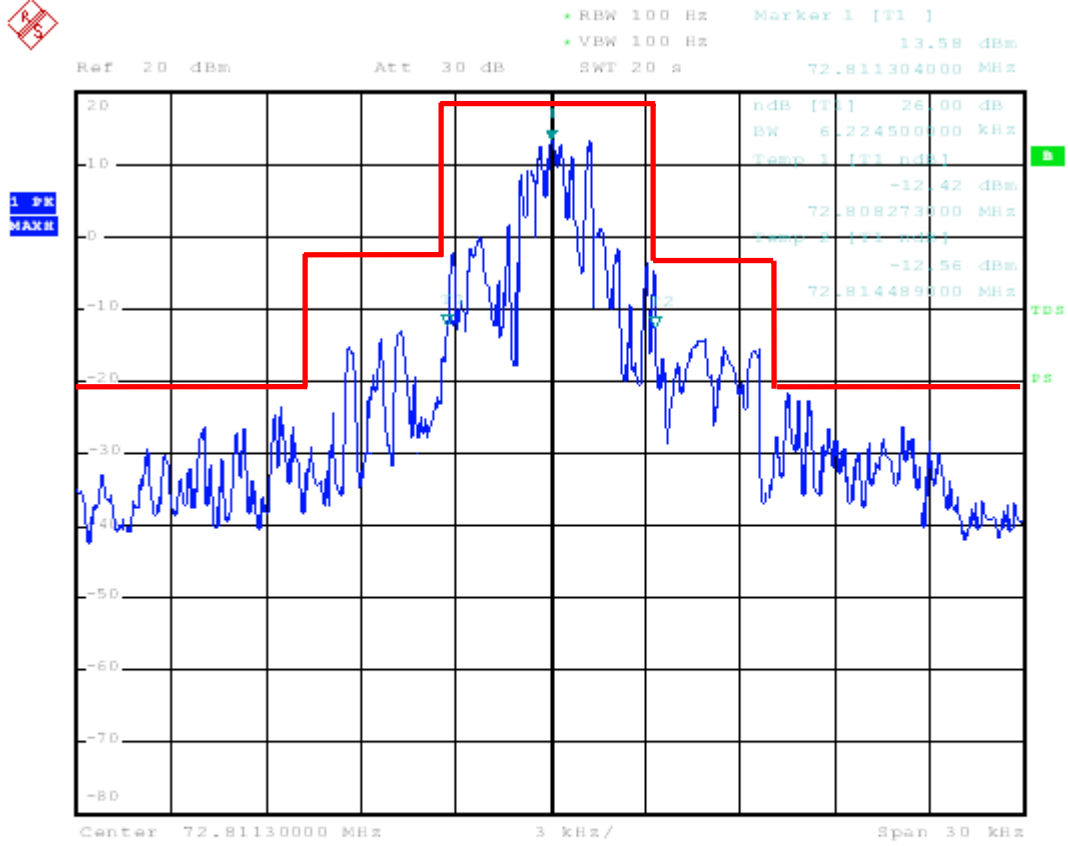

Date: 25.FEB.2006 08:05:47

6- §95.635(b)(1), §95.635(b)(3), §95.635(b)(7), §95.635(b)(10), §95.635(b)(11), §95.635(b)(12) - UNWANTED EMISSION

6.1 Standard Applicable

Per FCC §95.635 (b)(1), at least 25 dB (decibels) on any frequency removed from the center of the authorized bandwidth by more than 50% up to and including 100% of the authorized bandwidth.

Per FCC §95.635 (b)(3), at least 35 dB on any frequency removed from the center of the authorized bandwidth by more than 100% up to and including 250% of the authorized bandwidth.

Per FCC §95.635 (b)(7), at least $43 \pm 10 \log_{10} (T)$ dB on any frequency removed from the center of the authorized bandwidth by more than 250%.

Per FCC §95.635 (b)(10), At least 45 dB on any frequency removed from the center of the authorized bandwidth by more than 100% up to and including 125% of the authorized bandwidth.

Per FCC §95.635 (b)(11), At least 55 dB on any frequency removed from the center of the authorized bandwidth by more than 125% up to and including 250% of the authorized bandwidth.

Per FCC §95.635 (b)(12), At least $56 + 10 \log_{10} (T)$ dB on any frequency removed from the center of the authorized bandwidth by more than 250%.

6.2 Test Procedure

The procedure used was ANSI C63.4-2003. The unit was operating into its permanently attached antenna at a height of 117 cm. The spectrum was scanned from 30 to at least the tenth harmonic of the fundamental using a spectrum analyzer and an appropriate antenna. The measurement antenna was placed at a distance of 3 meters from the EUT. During the tests, the antenna height and polarization as well as EUT azimuth were varied in order to identify the maximum level of emissions from the EUT. Remove the EUT and replace it with substitution antenna. A signal generator was connected to the substitution antenna by a non-radiating cable. The absolute levels of the spurious emissions were measured by the substitution.

The test setup plot was followed:

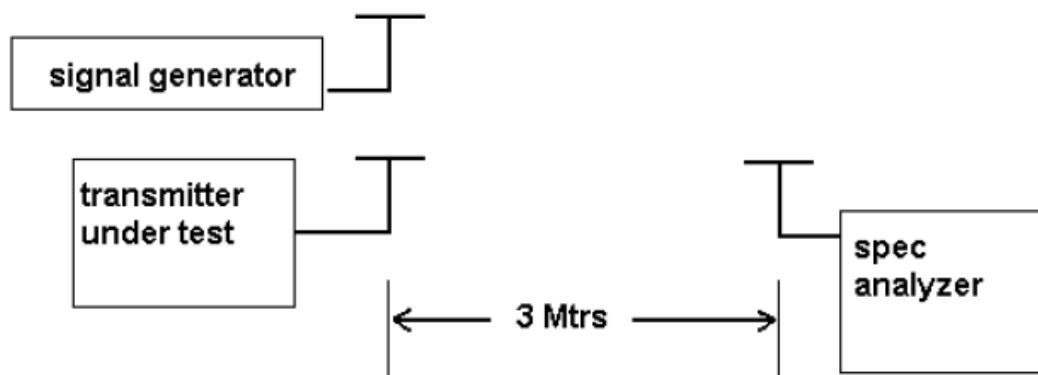

6.3 Unwanted Emission Test Result

Temperature ()	22~23
Humidity (%RH)	50~54
Barometric Pressure (mbar)	950~1000
EUT	Transmitter for R/C Helicopter
M/N	WK-0701
Operating Mode	Continuous Transmitting

Note:

Calculation of FCC Limit was: $56+10 \log_{10}(0.017)=38.3\text{dB}$

Test Result used Substitution Method:

Indicated		Table	Test Antenna			Substituted		Antenna Gain Correction	Cable Loss dB	Absolute Level dBm	Limit dBm	Margin dB
Frequency MHz	Meter Reading dBuV/m		Angle Degree	Height Meter	Polar H/V	Frequency MHz	Level dBm					
72.81	98.70	175	1.2	V	72.81	10.10	2.4	0.1	12.40	/	/	
87.38	36.50	175	1.2	V	87.38	-31.80	2.4	0.1	-29.50	-26	3.50	
145.62	38.63	182	1.1	V	145.62	-31.70	3.3	0.2	-28.60	-26	2.60	
218.43	34.25	120	1.1	V	218.43	-35.45	3.1	0.2	-32.55	-26	6.55	
291.24	32.75	175	1.1	V	291.24	-40.20	3.2	0.1	-37.10	-26	11.10	
364.06	38.50	175	1.2	V	364.06	-47.05	4.0	0.1	-43.15	-26	17.15	
436.87	37.95	180	1.0	V	436.87	-46.40	3.9	0.1	-42.60	-26	16.60	
509.68	38.35	178	1.1	V	509.68	-50.40	4.1	0.2	-46.50	-26	20.50	
582.49	34.20	175	1.1	V	582.49	-52.10	4.1	0.2	-48.20	-26	22.20	
655.30	32.80	120	1.1	V	655.30	-53.00	4.2	0.2	-49.00	-26	23.00	
720.81	32.75	350	1.1	V	720.81	-53.00	4.2	0.2	-49.00	-26	23.00	
72.81	81.50	175	1.2	H	72.81	0.90	2.3	0.1	3.10	/	/	
87.38	34.70	182	1.1	H	87.38	-39.90	2.3	0.1	-37.70	-26	11.70	
145.62	35.70	180	1.1	H	145.62	-38.90	3.3	0.2	-35.80	-26	9.80	
218.43	33.10	355	1.0	H	218.43	-39.10	3.2	0.2	-36.10	-26	10.10	
291.24	29.78	175	1.2	H	291.24	-45.00	3.2	0.2	-42.00	-26	16.00	
364.06	33.60	175	1.2	H	364.06	-47.85	3.9	0.2	-44.15	-26	18.15	
436.87	32.55	181	1.1	H	436.87	-48.90	3.9	0.2	-45.20	-26	19.20	
509.68	33.35	180	1.2	H	509.68	-52.30	4.0	0.2	-48.50	-26	22.50	
582.49	30.20	352	1.1	H	582.49	-52.30	4.2	0.2	-48.30	-26	22.30	
655.30	29.75	175	1.1	H	655.30	-53.10	4.2	0.2	-49.10	-26	23.10	
720.81	29.30	175	1.1	H	720.81	-53.10	4.2	0.2	-49.10	-26	23.10	

7- FREQUENCY STABILITY MEASUREMENT

7.1 Standard Applicable

According to FCC §2.1055(a)(1), the frequency stability shall be measure with variation of ambient temperature from -30°C to $+50^{\circ}\text{C}$, and according to FCC 2.1055(d)(2), the frequency stability shall be measured with reducing primary supply voltage to the battery operating end point which is specified by the manufacturer.

According to FCC §95.623(c), All R/C transmitters capable of operation in the 72-76 MHz band that are manufactured in or imported into the United States, on or after March 1, 1992, or are marketed on or after March 1, 1993, must be maintained within a frequency tolerance of 0.002%.

7.2 Test Procedure

Frequency stability versus environmental temperature

The equipment under test was connected to an external DC power supply and the RF output was connected to a frequency counter via feedthrough attenuators. The EUT was placed inside the temperature chamber at 25 degrees C and allowed to stabilize for one hour. The transmitter was keyed ON for one minute during which four frequency readings were recorded at 15-second intervals. The worse case number was taken for temperature plotting. The assigned channel frequency was considered to be the reference frequency. The temperature was then reduced to -30 degrees C after which the transmitter was again allowed to stabilize for one Hour. The transmitter was keyed ON for one minute, and again frequency readings were noted at 15-second intervals. The worst-case Number was recorded for temperature plotting. This procedure was repeated in 10 degree increments up to $+50$ degrees C.

Frequency Stability versus Input Voltage

At room temperature ($25\pm 5^{\circ}\text{C}$), an external variable DC power supply was connected to the EUT. Readings were also taken at the end point of the battery voltage of 12.0VDC.

7.3 Frequency Stability Test Result

Temperature ()	22~23
Humidity (%RH)	50~54
Barometric Pressure (mbar)	950~1000
EUT	Transmitter for R/C Helicopter
M/N	WK-0701
Operating Mode	Continuous Transmitting

Reference Frequency: 72.81 MHz, Limit: +/-0.002%			
Environment Temperature (°C)	Power Supplied (VDC)	Frequency Measure with Time Elapsed	
		MCF (MHz)	Error %
50	12	72.81135	+0.0019
40	12	72.81131	+0.0018
30	12	72.81128	+0.0018
20	12	72.81125	+0.0017
10	12	72.81130	+0.0018
0	12	72.81112	+0.0015
-10	12	72.81095	+0.0013
-20	12	72.81088	+0.0012
-30	12	72.81101	+0.0014

So, Frequency Stability Versus Input Voltage is:

Reference Frequency: 72.81 MHz, Limit: +/-0.002%		
Power Supplied (VDC)	Frequency Measure with Time Elapsed	
	Frequency (MHz)	Error %
5	72.81120	+0.0016