

FCC 47 CFR PART 15 SUBPART E

CERTIFICATION TEST REPORT

For

**Transmitter for R/C Helicopter
MODEL NUMBER: DEVO F8S**

FCC ID: S29DEVOF8S

REPORT NUMBER: 4788110856-2-8

ISSUE DATE: October 16, 2017

Prepared for

**GUANGZHOU Walkera Technology Co., Ltd
Taishi Industrial Park, Dongchong Town, Panyu District, Guangzhou, China**

Prepared by

**UL Verification Services (Guangzhou) Co., Ltd, Song Shan Lake Branch
Room 101, Building 10, Innovation Technology Park,
Song Shan Lake Hi tech Development Zone, Dongguan, 523808, China
Tel: +86 769 33817100
Fax: +86 769 33244054
Website: www.ul.com**

Revision History

<u>Rev.</u>	<u>Issue Date</u>	<u>Revisions</u>	<u>Revised By</u>
--	10/16/2017	Initial Issue	

Summary of Test Results			
Clause	Test Items	FCC/IC Rules	Test Results
1	6/26db Bandwidth	FCC 15.407 (e)	Complied
2	Maximum Conducted Output Power	FCC 15.407 (a)	Complied
3	Power Spectral Density	FCC 15.407 (a)	Complied
4	Antenna Conducted Spurious Emission	FCC 15.407 (b)	Complied
5	Radiated Bandedge and Spurious Emission	FCC 15.407 (a) FCC 15.209 FCC 15.205	Complied
6	Conducted Emission Test For AC Power Port	FCC 15.207	Complied
7	Antenna Requirement	FCC 15.203	Complied
8	Frequency Stability	FCC 15.407 (g)	Complied
9	Dynamic Frequency Selection	FCC 15.407 (h)	Complied

TABLE OF CONTENTS

1. ATTESTATION OF TEST RESULTS	5
2. TEST METHODOLOGY	6
3. FACILITIES AND ACCREDITATIO	6
4. CALIBRATION AND UNCERTAINTY	7
4.1. <i>MEASURING INSTRUMENT CALIBRATION</i>	7
4.2. <i>MEASUREMENT UNCERTAINTY</i>	7
5. EQUIPMENT UNDER TEST	8
5.1. <i>DESCRIPTION OF EUT</i>	8
5.2. <i>MAXIMUM OUTPUT POWER</i>	8
5.3. <i>CHANNEL LIST</i>	8
5.4. <i>TEST CHANNEL CONFIGURATION</i>	8
5.5. <i>THE WORSE CASE POWER SETTING PARAMETER</i>	9
5.6. <i>DESCRIPTION OF AVAILABLE ANTENNAS</i>	9
5.7. <i>DESCRIPTION OF TEST SETUP</i>	9
5.8. <i>MEASURING INSTRUMENT AND SOFTWARE USED</i>	11
6. ANTENNA PORT TEST RESULTS	13
6.1. <i>ON TIME AND DUTY CYCLE</i>	13
6.2. <i>6 dB BANDWIDTH</i>	17
6.3. <i>MAXIMUM CONDUCTED OUTPUT POWER</i>	20
6.3.1. <i>802.11n HT 20 MODE</i>	21
6.4. <i>POWER SPECTRAL DENSITY</i>	22
6.4.1. <i>802.11n HT 20 MODE</i>	23
<i>RADIATED TEST RESULTS</i>	26
6.5. <i>LIMITS AND PROCEDURE</i>	26
6.6. <i>RESTRICTED BANDEDGE</i>	30
6.6.1. <i>802.11n HT 20 MODE</i>	30
6.7. <i>SPURIOUS EMISSIONS (1~18GHz)</i>	34
6.7.1. <i>802.11n HT 20 MODE</i>	34
6.8. <i>SPURIOUS EMISSIONS BELOW 1 GHz</i>	37
6.8.1. <i>802.11n HT20 MODE</i>	37
6.9. <i>SPURIOUS EMISSIONS BELOW 30M</i>	39
7. AC POWER LINE CONDUCTED EMISSIONS	40
8. FREQUENCY STABILITY	43
9. ANTENNA REQUIREMENTS	46

1. ATTESTATION OF TEST RESULTS

Applicant Information

Company Name: GuangZhou Walkera Technology Co., Ltd
Address: Taishi Industrial Park, Dongchong Town, Panyu District, Guangzhou, China

Manufacturer Information

Company Name: GuangZhou Walkera Technology Co., Ltd
Address: Taishi Industrial Park, Dongchong Town, Panyu District, Guangzhou, China

Factory Information

Company Name: GuangZhou Walkera Technology Co., Ltd
Address: Taishi Industrial Park, Dongchong Town, Panyu District, Guangzhou, China

EUT Name: Transmitter for R/C Helicopter
Model: DEVO F8S

Brand: WALKERA
Sample Received: August 25, 2017
Date of Tested: August 26, 2017~September 19, 2017

APPLICABLE STANDARDS	
STANDARD	TEST RESULTS
CFR 47 Part 15 Subpart E	Pass

Tested By : 

Sam Li
Engineer
Approved By:

Check By: 

Shawn Wen
Laboratory Leader



Stephen Guo
Laboratory Manager

2. TEST METHODOLOGY

The tests documented in this report were performed in accordance with ANSI C63.10-2013, FCC CFR 47 Part 2 and FCC CFR 47 Part 15.

3. FACILITIES AND ACCREDITATIO

Test Location	Dongguan Dongdian Testing Service Co., Ltd
Address	No. 17, Zongbu Road 2, Songshan Lake Sci&Tech Park, Dongguan City, Guangdong Province, 523808, China
Accreditation Certificate	<p>Dongguan Dongdian Testing Service Co., Ltd.</p> <p>EMC Laboratory has been accredited by A2LA for technical competence in the field of electrical testing, and proved to be in compliance with ISO/IEC 17025: 2005 General Requirements for the Competence of Testing and Calibration Laboratories and any additional program requirements in the identified field of testing. Valid time is until January 31, 2018.</p> <p>EMC Laboratory has been registered and fully described in a report filed with the FCC (Federal Communications Commission). The acceptance letter from the FCC is maintained in our files. Registration 270092, Renewal date March 11, 2015, valid time is until March 11, 2018.</p> <p>The 3m Alternate Test Site of Dongguan Dongdian Testing Service Co., Ltd. has been registered by Certification and Engineering Bureau of Industry Canada for the performance of radiated measurements with Registration No. 10288A on April 23, 2015, valid time is until April 23, 2018.</p>

4. CALIBRATION AND UNCERTAINTY

4.1. MEASURING INSTRUMENT CALIBRATION

The measuring equipment utilized to perform the tests documented in this report has been calibrated in accordance with the manufacturer's recommendations, and is traceable to recognize national standards.

4.2. MEASUREMENT UNCERTAINTY

Where relevant, the following measurement uncertainty levels have been estimated for tests performed on the apparatus:

Test Item	Uncertainty
Occupied Channel Bandwidth	±1%
Uncertainty for radio frequency	1×10 ⁻⁹
RF Output power, conducted	±0.6dB
Power Spectral Density, Conducted	±1.2dB
Unwanted Emissions, Conducted	±0.6dB
Temperature	±0.2°C
Humidity	±1%
DC and Low frequency voltage	±0.5%
Time	±1%
Duty Cycle	±1%
Uncertainty for Radiation Emission test (30MHz-1GHz)	3.14 dB (Polarize: V)
	3.16 dB (Polarize: H)
Uncertainty for Radiation Emission test (1GHz to 40GHz)	2.08dB(Polarize: V)
	2.56dB (Polarize: H)
	4.30dB (26GHz-40Gz)
Uncertainty for Conduction emission test(150KHz-30MHz)	2.44dB
Uncertainty for Radiation Emission test (9KHz-150KHz)	3.89dB
Uncertainty for Radiation Emission test (150KHz-30MHz)	3.21dB

Uncertainty figures are valid to a confidence level of 95%,k=2.

5. EQUIPMENT UNDER TEST

5.1. DESCRIPTION OF EUT

Equipment	Transmitter for R/C Helicopter
Model Name	DEVO F8S
Battery	DC 7.4V, 2200mAh
Hardware Version	1.0
Software Version	1.0

5.2. MAXIMUM OUTPUT POWER

Frequency Range (MHz)	Max Number of Transmit chains (NTX)	IEE Std. 802.11	Frequency (MHz)	Channel Number	Max Power (dBm)	Max EIRP (dBm)
UNII-3	2	n(HT20)	5745-5825	149-165	23.44	N/A

5.3. CHANNEL LIST

UNII-3		UNII-3		UNII-3	
Channel	Frequency (MHz)	Channel	Frequency (MHz)	Channel	Frequency (MHz)
149	5745	151	5755	155	5775
153	5765	159	5795		
157	5785				
161	5805				
165	5825				

5.4. TEST CHANNEL CONFIGURATION

Pretest Test Mode	Description
Mode 20	TX N20 Mode / CH149,CH157,CH165 (UNII-3)

5.5. THE WORSE CASE POWER SETTING PARAMETER

UNII-3				
Test Software Version	Atheros Radio Test 2			
Test Mode	Setting TX Power	HT Mode	TX Pattern	TX Power Control
802.11n HT20	12	HT20_MCS_0_20	12Mbps	30
	12	HT20_MCS_0_20	12Mbps	30
	12	HT20_MCS_0_20	12Mbps	30

5.6. DESCRIPTION OF AVAILABLE ANTENNAS

Ant.	Frequency (MHz)	Antenna Type	Antenna Gain (dBi)
1	5745-5825	External Antenna	2.15
2	5745-5825	External Antenna	2.15
Ant1+Ant2	5745-5825	External Antenna	5.15

IEE Std. 802.11	Transmit and Receive Mode	Description
n(MCS0-7)	<input checked="" type="checkbox"/> 1TX, 1RX	Chain 1 can be used as transmitting/receiving antenna.
n(MCS0-7)	<input checked="" type="checkbox"/> 1TX, 1RX	Chain 2 can be used as transmitting/receiving antenna.
n(MCS0-7)	<input checked="" type="checkbox"/> 2TX, 2RX	Chain 1+2 can be used as transmitting/receiving antenna.

Note: 1. The EUT supports the diversity function for WLAN.
 2. All the modes had been tested but only the worst data in the report.

5.7. DESCRIPTION OF TEST SETUP

SUPPORT EQUIPMENT

Item	Equipment	Brand Name	Model Name	P/N
1	Laptop	ThinkPad	T460S	SL10K24796 JS

I/O CABLES

able No	Port	Connector Type	Cable Type	Cable Length(m)	Remarks
1	USB	USB Type C	shielded	0.55	N/A

ACCESSORY

Item	Accessory	Brand Name	Model Name	Description
1	N/A	N/A	N/A	N/A

TEST SETUP

The EUT can work in engineering mode with firmware Atheros Radio Test 2 through a Laptop.

SETUP DIAGRAM FOR TEST

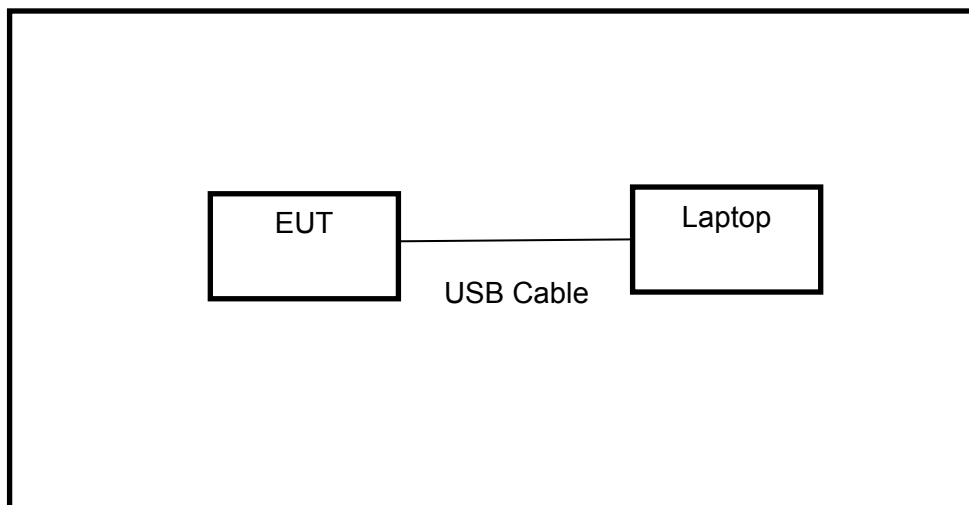

5.8. MEASURING INSTRUMENT AND SOFTWARE USED

Instrument (Conducted for RF Port)						
Used	Equipment	Manufacturer	Model No.	Serial No.	Last Cal.	Due. Date
<input checked="" type="checkbox"/>	Spectrum analyzer	R&S	FSU26	1166.1660.26	Oct. 16, 2016	Oct. 16, 2017
<input checked="" type="checkbox"/>	Vector Signal Generator	Agilent	E8267D	MY52098743	Oct. 20, 2016	Oct. 20, 2017
<input checked="" type="checkbox"/>	Vector Signal Generator	Agilent	N5182A	MY48180737	Jul. 05, 2017	Jul. 05, 2018
<input checked="" type="checkbox"/>	Power Sensor	Agilent	U2021XA	MY55150010	Apr. 18, 2017	Apr. 18, 2018
<input checked="" type="checkbox"/>	Power Sensor	Agilent	U2021XA	MY55150011	Apr. 19, 2017	Apr. 19, 2018
<input checked="" type="checkbox"/>	DC Power Source	MATRIS	MPS-3005L-3	D813058W	Oct. 24, 2016	Oct. 24, 2017
<input checked="" type="checkbox"/>	Attenuator	Mini-Circuits	BW-S10W2	101109	Aug. 18, 2017	Aug. 18, 2018
<input checked="" type="checkbox"/>	RF Cable	Micable	C10-01-01-1	100309	Aug. 18, 2017	Aug. 18, 2018
<input checked="" type="checkbox"/>	Test Software	JS Tonscend	JS1120-2	Ver.2.5	N/A	N/A
<input checked="" type="checkbox"/>	USB Data acquisition	Agilent	U2531A	TW55043503	N/A	N/A
<input checked="" type="checkbox"/>	Auto control Unit	JS Tonscend	JS0806-2	158060010	N/A	N/A
Instrument (Radiated Tests)						
Used	Equipment	Manufacturer	Model No.	Serial No.	Last Cal.	Expired date
<input checked="" type="checkbox"/>	EMI Test Receiver	R&S	ESU8	100316	Oct. 16, 2016	Oct. 16, 2017
<input checked="" type="checkbox"/>	Spectrum analyzer	R&S	FSU26	1166.1660.26	Oct. 16, 2016	Oct. 16, 2017
<input checked="" type="checkbox"/>	Trilog Broadband Antenna	Schwarzbeck	VULB9163	9163-462	Oct. 27, 2016	Oct. 27, 2017
<input checked="" type="checkbox"/>	Active Loop antenna	Schwarzbeck	FMZB-1519	1519-038	Oct. 16, 2016	Oct. 16, 2017
<input checked="" type="checkbox"/>	Double Ridged Horn Antenna	R&S	HF907	100276	Oct. 12, 2016	Oct. 12, 2017
<input checked="" type="checkbox"/>	Pre-amplifier	A.H.	PAM-0118	360	Oct. 16, 2016	Oct. 16, 2017
<input checked="" type="checkbox"/>	RF Cable	HUBSER	CP-X2	W11.03	Oct. 16, 2016	Oct. 16, 2017
<input checked="" type="checkbox"/>	RF Cable	HUBSER	CP-X1	W12.02	Oct. 16, 2016	Oct. 16, 2017
<input checked="" type="checkbox"/>	MI Cable	HUBSER	C10-01-01-1M	1091629	Oct. 16, 2016	Oct. 16, 2017
<input checked="" type="checkbox"/>	Test software	Audix	E3	V 6.11111b	/	/
Instrument (Line Conducted Emission (AC Main))						
Used	Equipment	Manufacturer	Model No.	Serial No.	Last Cal.	Expired date
<input checked="" type="checkbox"/>	Test Receiver	R&S	ESU8	100316	Oct.16, 2016	Oct.16, 2017
<input checked="" type="checkbox"/>	LISN 1	R&S	ENV216	101109	Oct.16, 2016	Oct.16, 2017

<input checked="" type="checkbox"/>	LISN 2	R&S	ESH2-Z5	100309	Oct.16, 2016	Oct.16, 2017
<input checked="" type="checkbox"/>	Pulse Limiter	R&S	ESH3-Z2	101242	Oct.16, 2016	Oct.16, 2017
<input checked="" type="checkbox"/>	CE Cable 1	HUBSER	ESU8/RF2	W10.01	Oct.16, 2016	Oct.16, 2017
<input checked="" type="checkbox"/>	Test software	Audix	E3	V 6.11111b	N/A	N/A

6. ANTENNA PORT TEST RESULTS

6.1. ON TIME AND DUTY CYCLE

LIMITS

None; for reporting purposes only.

RESULTS

Test Mode	Test Channel	Ant	Duty Cycle[%]	10log(1/x) Factor[dB]
11N20MIMO	5745	Ant1	100	0.00
11N20MIMO	5745	Ant2	100	0.00
11N20MIMO	5785	Ant1	100	0.00
11N20MIMO	5785	Ant2	100	0.00
11N20MIMO	5825	Ant1	100	0.00
11N20MIMO	5825	Ant2	100	0.00

Note: Duty Cycle Correction Factor= $10\log(1/x)$.
Where: x is Duty Cycle(Linear)

TEST CONDITIONS

Temperature: 25.6°C
Relative Humidity: 59%
Test Voltage: 7.4Vdc

DUTY CYCLE PLOTS

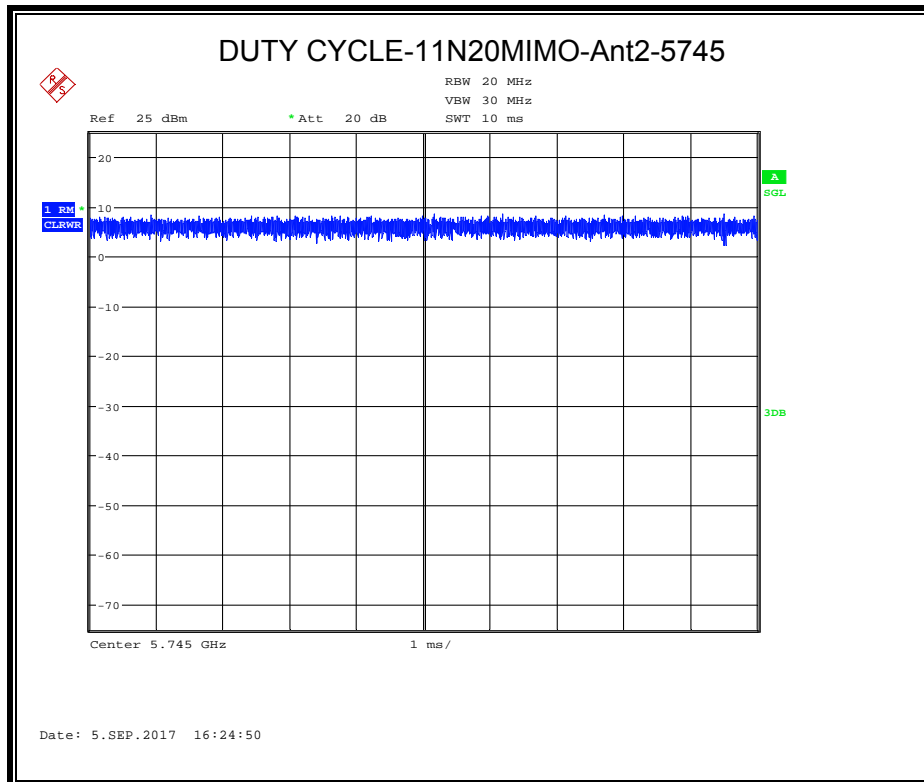
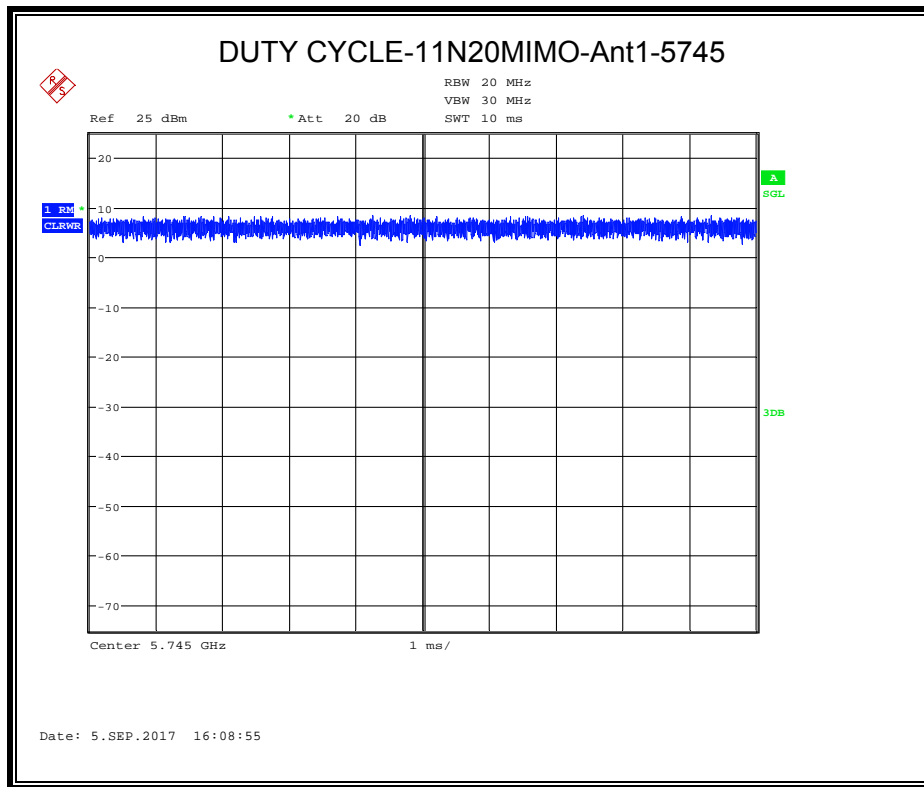

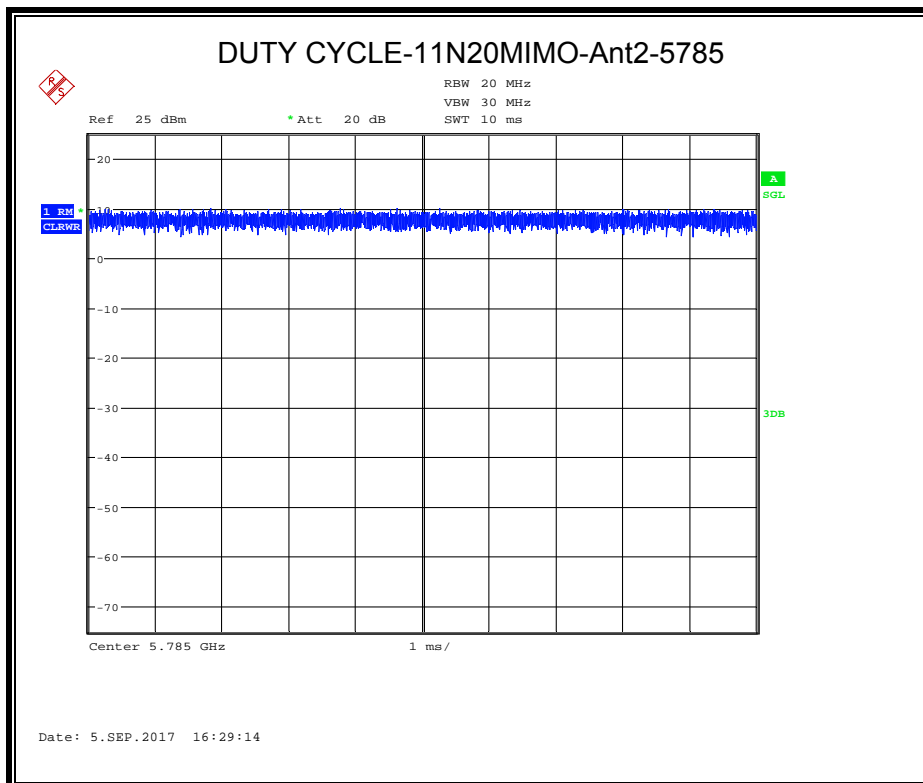
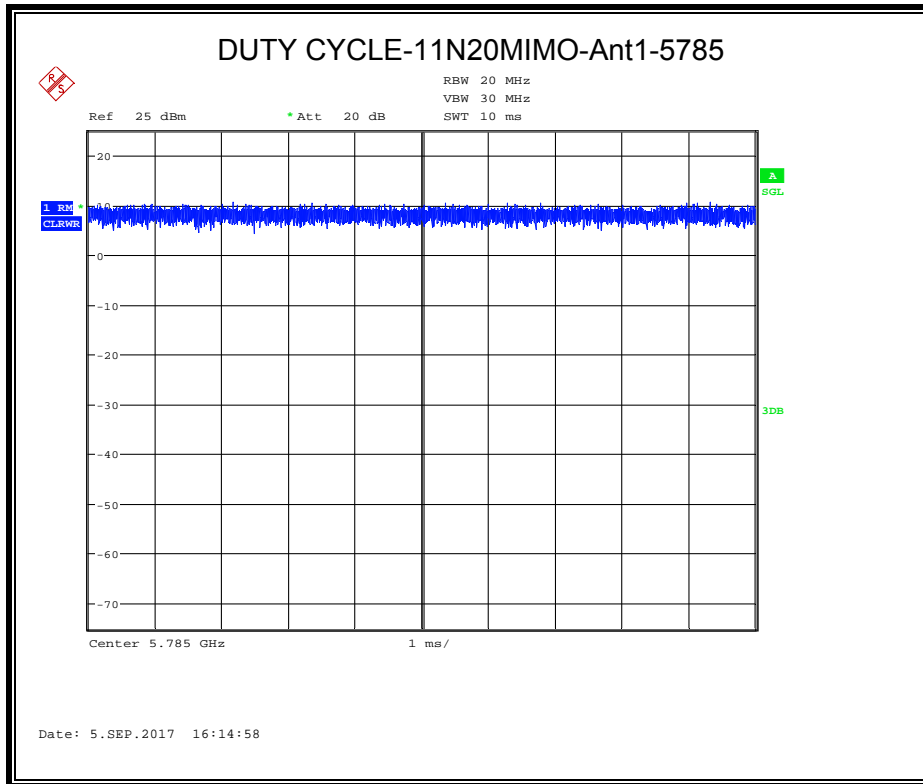

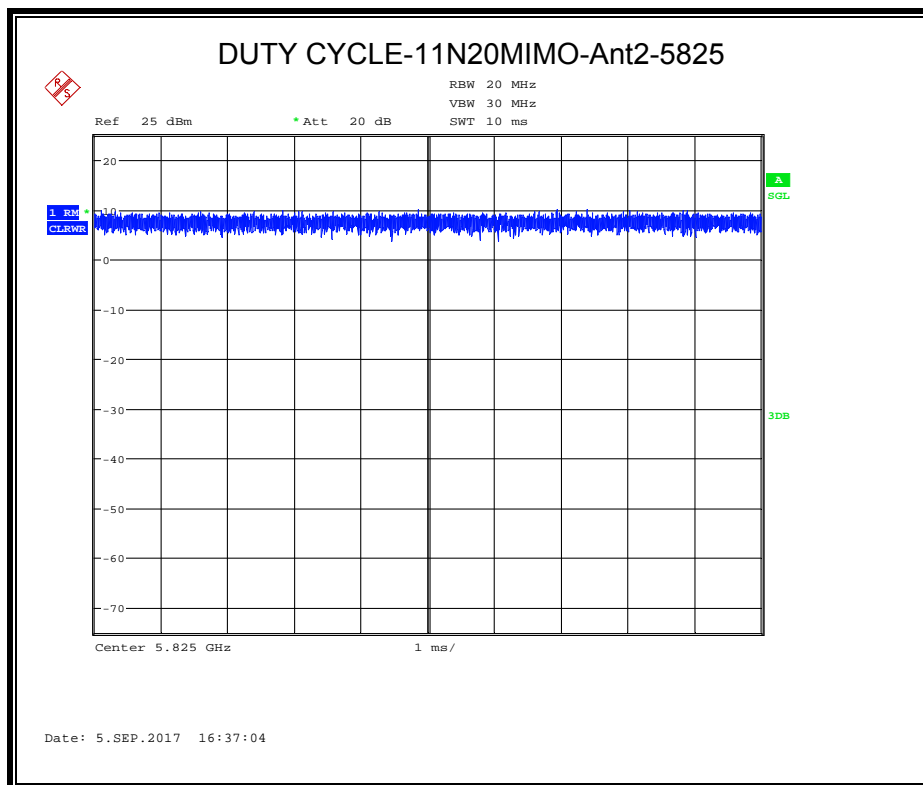
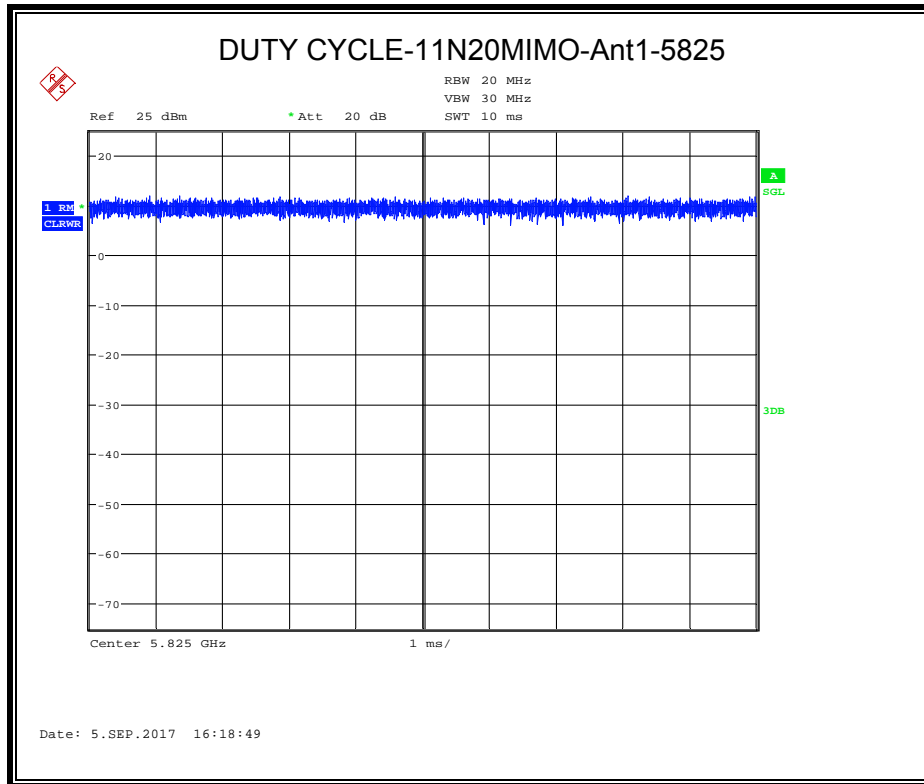

6.2. 6 dB BANDWIDTH

LIMITS

FCC Part15, Subpart E		
Test Item	Limit	Frequency Range (MHz)
Bandwidth	Minimum 500kHz 6dB Bandwidth	5745-5825

TEST PROCEDURE

Connect the UUT to the spectrum analyser and use the following settings:

Center Frequency	The centre frequency of the channel under test
Detector	Peak
RBW	RBW=100kHz
VBW	VBW=300kHz
Trace	Max hold
Sweep	Auto couple

Allow the trace to stabilize and measure the maximum width of the emission that is constrained by the frequencies associated with the two outermost amplitude points (upper and lower frequencies) that are attenuated by 6dB relative to the maximum level measured in the fundamental emission.

TEST SETUP

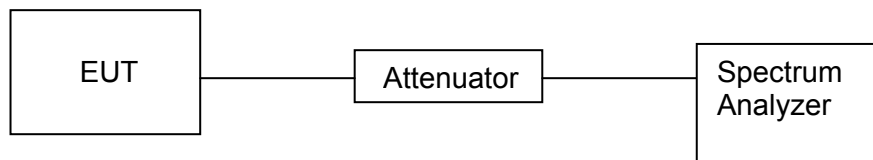

TEST CONDITIONS

Temperature: 25.6°C
 Relative Humidity: 59%
 Test Voltage: 7.4Vdc

RESULTS

802.11n HT 20 MODE

Result Table

Test Mode	Antenna	Channel	EBW[MHz]	Verdict
11N20	Ant1	5745	17.760	PASS
11N20	Ant2	5745	17.800	PASS
11N20	Ant1	5785	17.760	PASS
11N20	Ant2	5785	17.760	PASS

11N20	Ant1	5825	17.760	PASS
11N20	Ant2	5825	17.720	PASS

Test Graph

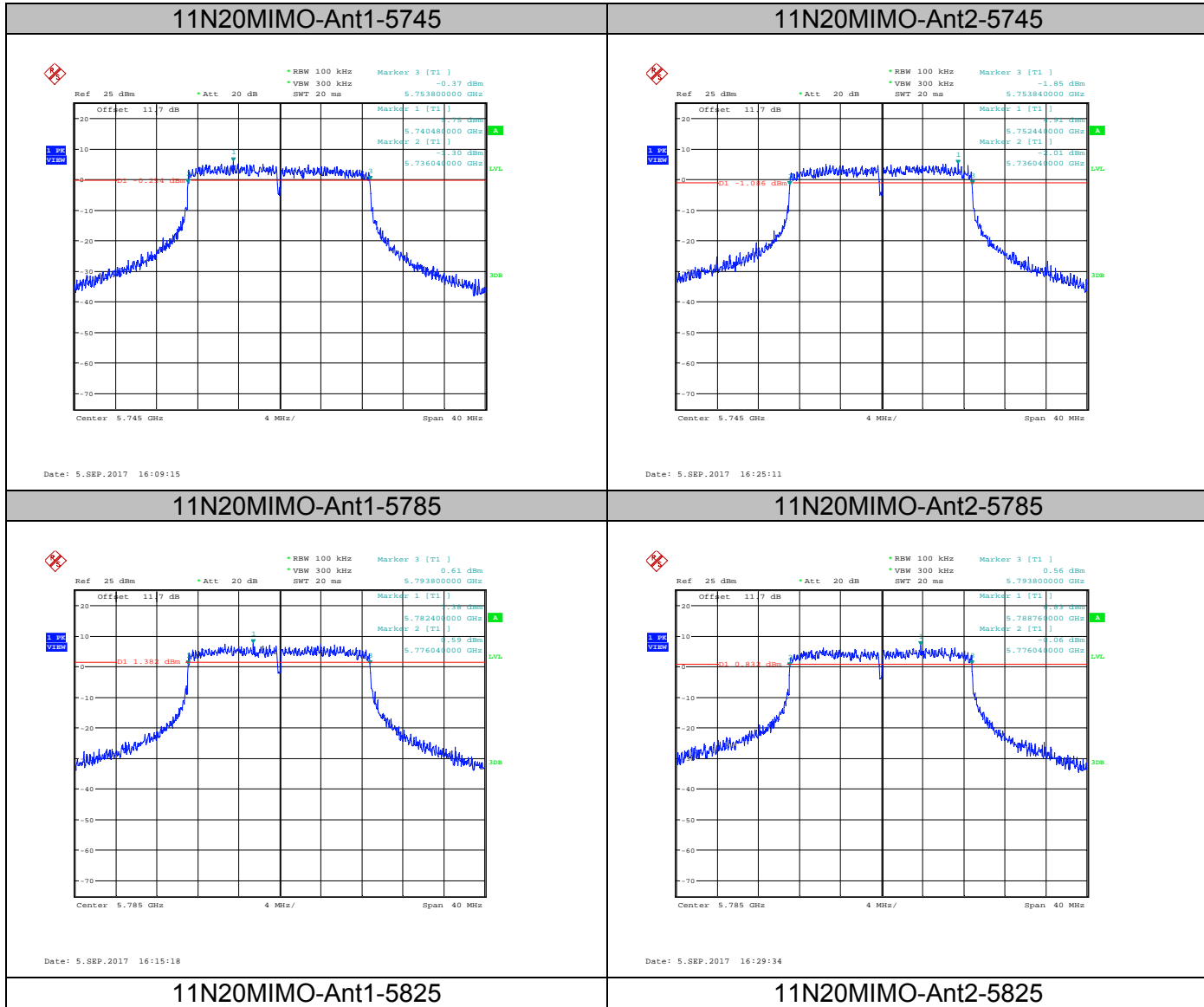

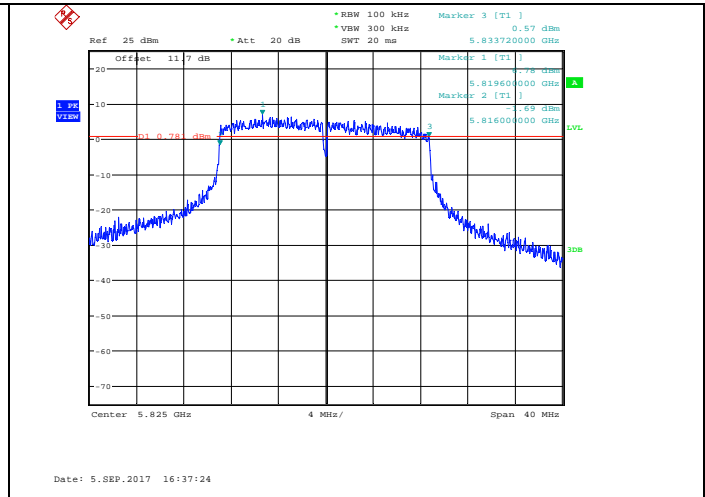
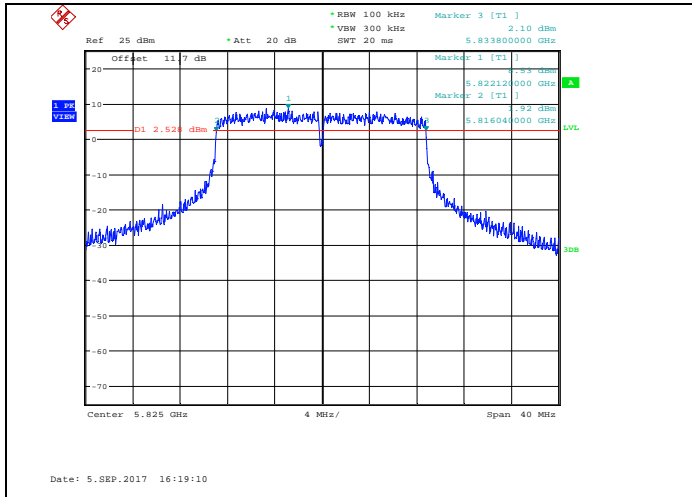

6.3. MAXIMUM CONDUCTED OUTPUT POWER

LIMITS

FCC Part15, Subpart E		
Test Item	Limit	Frequency Range (MHz)
Conducted Output Power	1 Watt (30dBm)	5745-5825

TEST PROCEDURE

Refer to KDB 789033 D02 General UNII Test Procedures New Rules v01r04

Connect the EUT to the a broadband peak RF power meter, the power meter shall have a video bandwidth that is greater than or equal to the bandwidth and shall utilize a fast-responding diode detector.

TEST SETUP

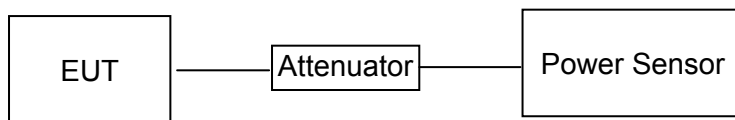

TEST CONDITIONS

Temperature: 25.6°C
Relative Humidity: 59%
Test Voltage: 7.4Vdc

RESULTS

6.3.1. 802.11n HT 20 MODE

6.3.1.1. UNII-3 BAND

Test Mode	Test Channel	Ant	Level [dBm]	10log(1/x) Factor [dB]	Power [dBm]	Limit [dBm]	Verdict
11N20MIMO	5745	Ant1	18.91	0.00	18.91	30.00	PASS
11N20MIMO	5745	Ant2	18.63	0.00	18.63	30.00	PASS
11N20MIMO	5745	Ant1+Ant2	21.78	---	21.78	30.00	PASS
11N20MIMO	5785	Ant1	20.76	0.00	20.76	30.00	PASS
11N20MIMO	5785	Ant2	19.72	0.00	19.72	30.00	PASS
11N20MIMO	5785	Ant1+Ant2	23.28	---	23.28	30.00	PASS
11N20MIMO	5825	Ant1	21.47	0.00	21.47	30.00	PASS
11N20MIMO	5825	Ant2	19.07	0.00	19.07	30.00	PASS
11N20MIMO	5825	Ant1+Ant2	23.44	---	23.44	30.00	PASS

NOTE: 1.EIRP= Maximum Conducted Output Power + ANT GAIN

2. Maximum Conducted Output Power= Conducted Output Power+ Correction Factor

3. The antenna co-related and directional gain= $2.15+10\text{LOG}(2)=5.16\text{dB}$.

4. About correction Factor please refer to section 6.1

6.4. POWER SPECTRAL DENSITY

LIMITS

FCC Part15, Subpart E		
Test Item	Limit	Frequency Range (MHz)
Power Spectral Density	30dBm/500kHz	5745-5825

TEST PROCEDURE

Connect the UUT to the spectrum analyser and use the following settings:

5745MHz-5825MHz

Center Frequency	The centre frequency of the channel under test
Detector	RMS
RBW	500KHz
VBW	$\geq 3 \times \text{RBW}$
Span	Encompass the entire emissions bandwidth (EBW) of the signal
Trace	Max hold
Sweep time	Auto

Note:

1. For UNII-3, according to KDB publication 789033 D02 General UNII Test Procedures New Rules v01, section II.F.5., it is acceptable to set RBW at 1MHz and VBW at 3MHz if the spectrum analyzer does not have 500kHz RBW.
2. The value measured with RBW=1MHz is to be added with $10\log(500\text{kHz}/1\text{MHz})$ which is -3dB. For example, if the measured value is +10dBm using RBW=1MHz (that is +10dBm/MHz), then the converted value will be +7dBm/500kHz.

Allow trace to fully stabilize and use the peak marker function to determine the maximum amplitude level within the RBW.

TEST SETUP

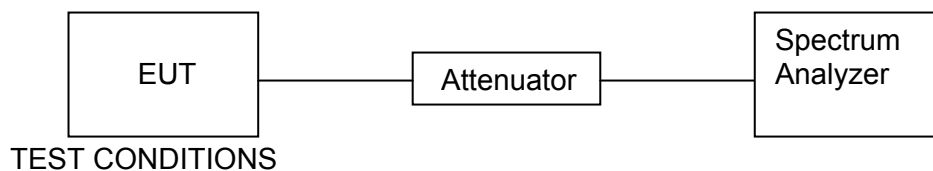

Temperature: 25.6°C
 Relative Humidity: 59%
 Test Voltage: 7.4Vdc

RESULTS

6.4.1. 802.11n HT 20 MODE

Result Table

Test Channel I	Ant	Level [dBm/500kHz]	10log(1/x) Factor[dB]	10log(500kHz/RBW) Factor [dB]	PSD [dBm/500kHz]	Limit [dBm/500kHz]	Verdict
5745	Ant1	6.27	0.00	0.00	6.27	30.00	PASS
5745	Ant2	6.36	0.00	0.00	6.36	30.00	PASS
5745	Ant1+Ant2	9.33	---	---	9.33	30.00	PASS
5785	Ant1	7.81	0.00	0.00	7.81	30.00	PASS
5785	Ant2	6.99	0.00	0.00	6.99	30.00	PASS
5785	Ant1+Ant2	10.43	---	---	10.43	30.00	PASS
5825	Ant1	8.17	0.00	0.00	8.17	30.00	PASS
5825	Ant2	6.59	0.00	0.00	6.59	30.00	PASS
5825	Ant1+Ant2	10.46	---	---	10.46	30.00	PASS

Note:1.PSD=Meas.Level+ Correction Factor
 2.About correction Factor please refer to section 6.1

Test Graph

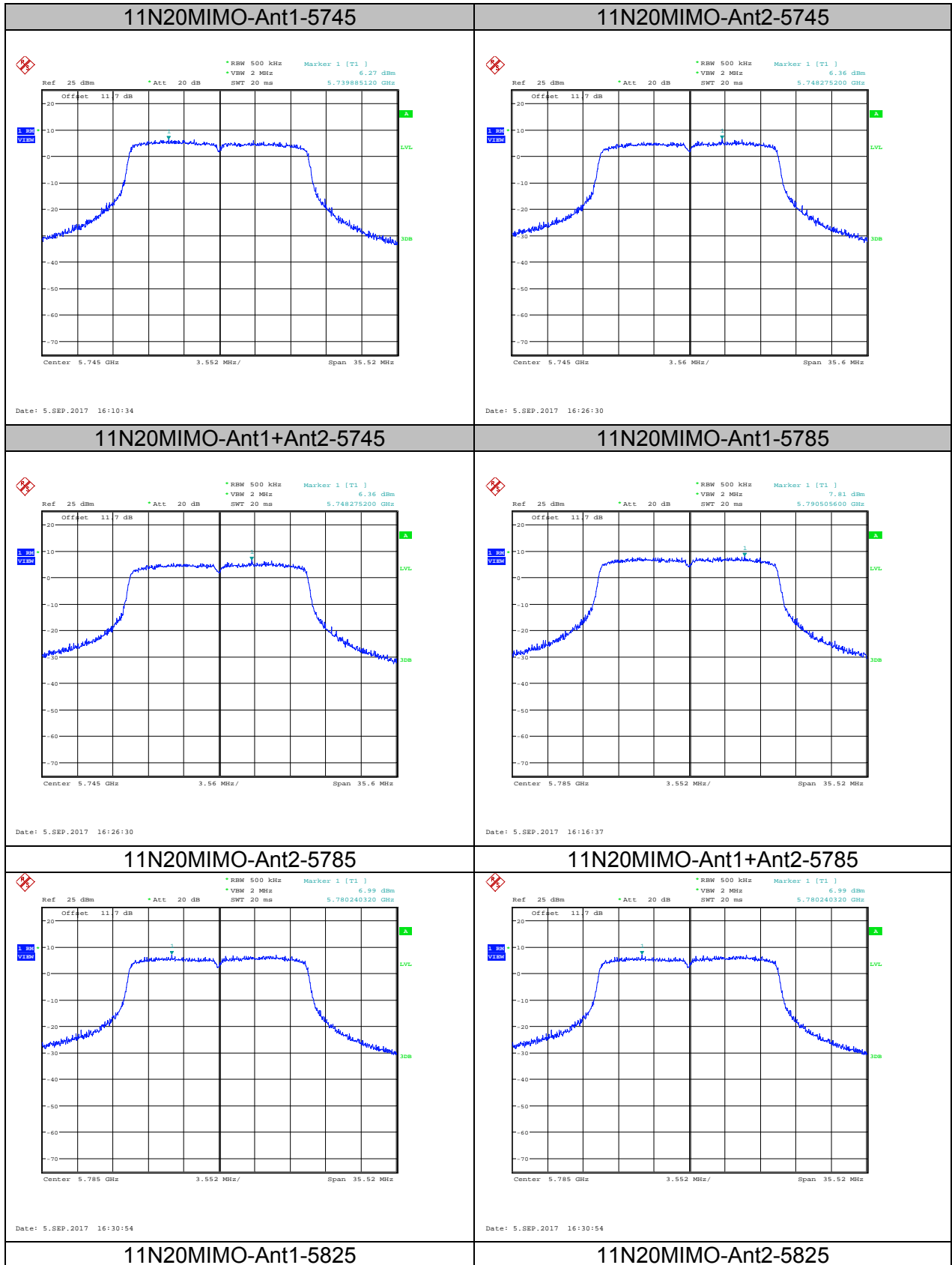

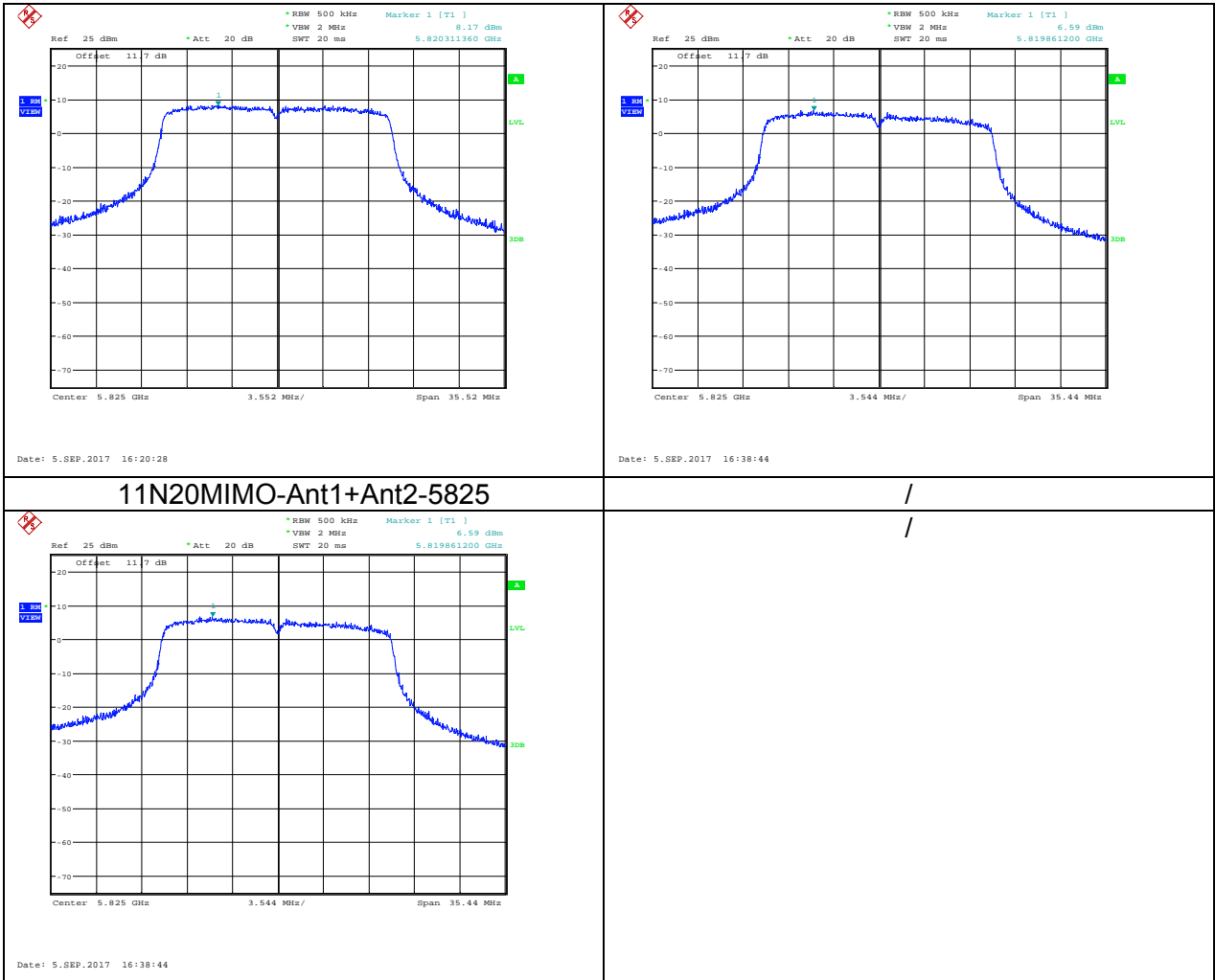

RADIATED TEST RESULTS

6.5. LIMITS AND PROCEDURE

LIMITS

Please refer to FCC §15.205 and §15.209

LIMITS OF RADIATED EMISSION MEASUREMENT (Below 1GHz)			
Frequency Range (MHz)	Field Strength Limit (uV/m) at 3 m	Field Strength Limit (dBuV/m) at 3 m	
		Quasi-Peak	
30 - 88	100	40	
88 - 216	150	43.5	
216 - 960	200	46	
Above 960	500	54	
Above 1000	500	Peak	Average
		74	54

§15.205 Restricted bands of operation

MHz	MHz	MHz	GHz
0.090-0.110	16.42-16.423	399.9-410	4.5-5.15
0.495-0.505	16.69475-16.69525	608-614	5.35-5.46
2.1735-2.1905	16.80425-16.80475	960-1240	7.25-7.75
4.125-4.128	25.5-25.67	1300-1427	8.025-8.5
4.17725-4.17775	37.5-38.25	1435-1626.5	9.0-9.2
4.20725-4.20775	73-74.6	1645.5-1646.5	9.3-9.5
6.215-6.218	74.8-75.2	1660-1710	10.6-12.7
6.26775-6.26825	108-121.94	1718.8-1722.2	13.25-13.4
6.31175-6.31225	123-138	2200-2300	14.47-14.5
8.291-8.294	149.9-150.05	2310-2390	15.35-16.2
8.362-8.366	156.52475-156.52525	2483.5-2500	17.7-21.4
8.37625-8.38675	156.7-156.9	2690-2900	22.01-23.12
8.41425-8.41475	162.0125-167.17	3260-3267	23.6-24.0
12.29-12.293	167.72-173.2	3332-3339	31.2-31.8
12.51975-12.52025	240-285	3345.8-3358	36.43-36.5
12.57675-12.57725	322-335.4	3600-4400	(²)
13.36-13.41			

TEST SETUP AND PROCEDURE

Below 30MHz

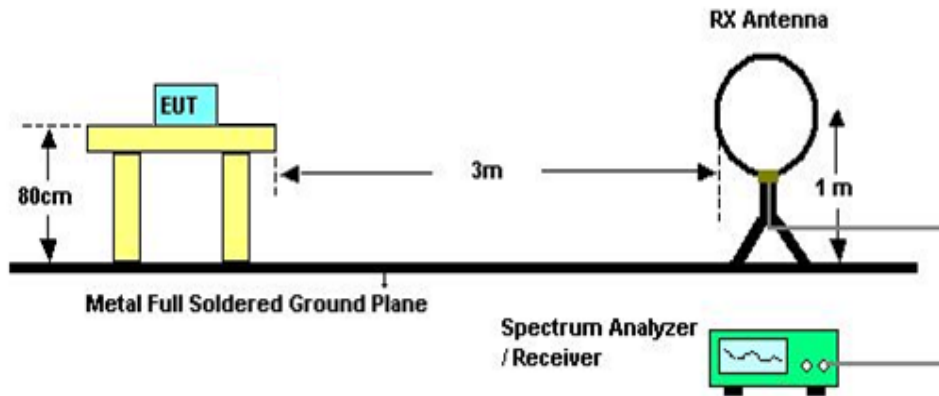

The setting of the spectrum analyser

RBW	200Hz (From 9kHz to 0.15MHz)/ 9KHz (From 0.15MHz to 30MHz)
VBW	200Hz (From 9kHz to 0.15MHz)/ 9KHz (From 0.15MHz to 30MHz)
Sweep	Auto
Detector	Peak/QP/ Average
Trace	Max hold

1. The testing follows the guidelines in ANSI C63.10-2013
2. The EUT was arranged to its worst case and then turntable (from 0 degree to 360 degrees) to find the maximum reading. A pre-amp and a high pass filter are used for the test in order to get better signal level. Both horizontal and vertical polarizations of the antenna are set to make the measurement.
3. The EUT was placed on a turntable with 0.8 meter above ground.
4. The EUT was set 3 meters from the interference receiving antenna, which was mounted on the top of a variable height antenna tower.
5. Corrected Reading: Antenna Factor + Cable Loss + Read Level - Preamp Factor = Level
6. For measurement below 1GHz, the initial step in collecting conducted emission data is a spectrum analyzer peak detector mode pre-scanning the measurement frequency range. Significant peaks are then marked and then Quasi Peak detector mode re-measured. If the emission level of the EUT measured by the peak detector is 3 dB lower than the applicable limit, the peak emission level will be reported. Otherwise, the emission measurement will be repeated using the quasi-peak detector and reported.
7. For the actual test configuration, please refer to the related item in this test report (Photographs of the Test Configuration)

Below 1G

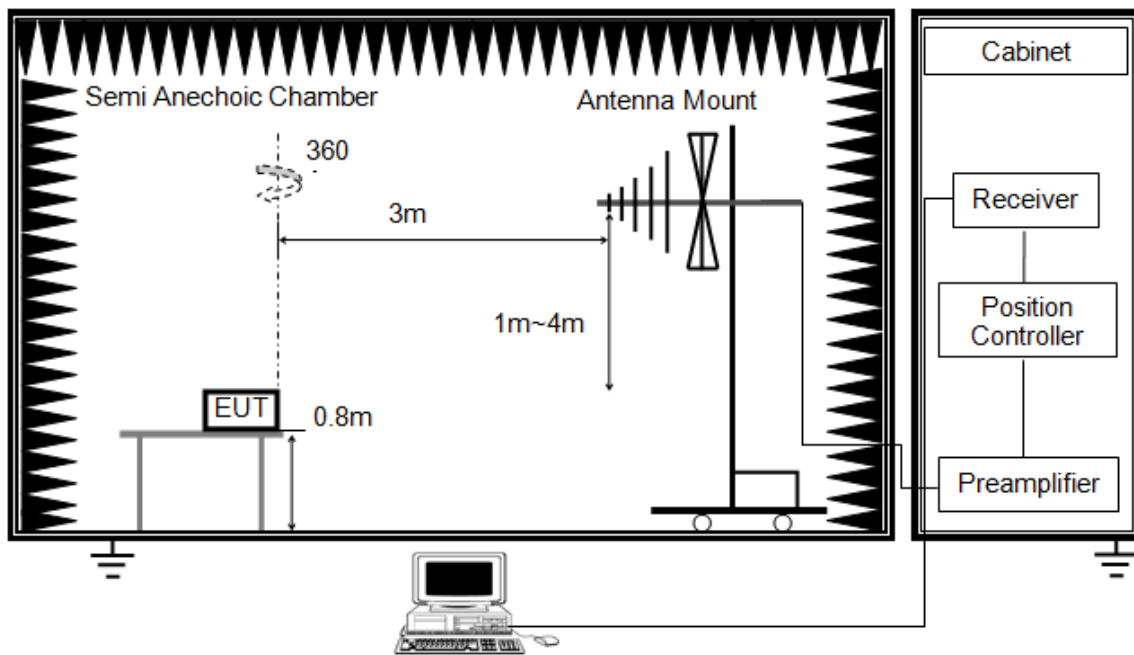

The setting of the spectrum analyser

RBW	120K
VBW	300K
Sweep	Auto
Detector	Peak/QP
Trace	Max hold

1. The testing follows the guidelines in ANSI C63.10-2013.
2. The EUT was arranged to its worst case and then tune the antenna tower (from 1 m to 4 m) and turntable (from 0 degree to 360 degrees) to find the maximum reading. A pre-amp and a high pass filter are used for the test in order to get better signal level. Both horizontal and vertical polarizations of the antenna are set to make the measurement.
3. The EUT was placed on a turntable with 0.8 meter above ground.
4. The EUT was set 3 meters from the interference receiving antenna, which was mounted on the top of a variable height antenna tower.
5. Corrected Reading: $\text{Antenna Factor} + \text{Cable Loss} + \text{Read Level} - \text{Preamp Factor} = \text{Level}$
6. For measurement below 1GHz, the initial step in collecting conducted emission data is a spectrum analyzer peak detector mode pre-scanning the measurement frequency range. Significant peaks are then marked and then Quasi Peak detector mode re-measured. If the emission level of the EUT measured by the peak detector is 3 dB lower than the applicable limit, the peak emission level will be reported. Otherwise, the emission measurement will be repeated using the quasi-peak detector and reported.
7. For the actual test configuration, please refer to the related Item in this test report (Photographs of the Test Configuration)

ABOVE 1G

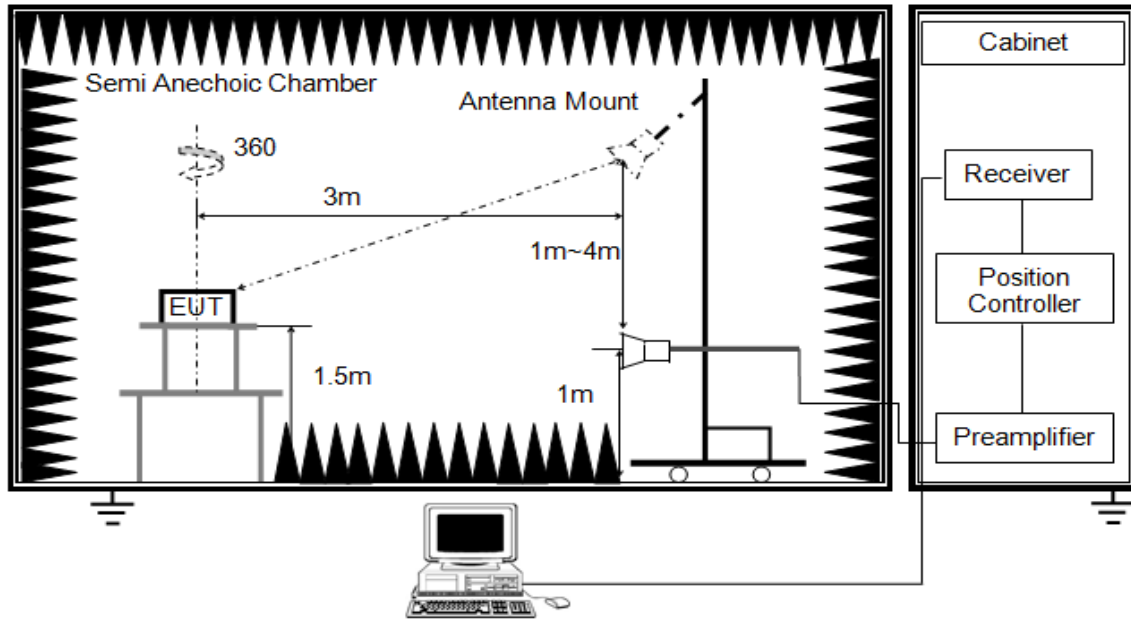

The setting of the spectrum analyser

RBW	1M
VBW	3M
Sweep	Auto
Detector	Peak and CISPR Average
Trace	Max hold

1. The testing follows the guidelines in ANSI C63.10-2013.
2. The EUT was arranged to its worst case and then tune the antenna tower (from 1 m to 4 m) and turntable (from 0 degree to 360 degrees) to find the maximum reading. A pre-amp and a high pass filter are used for the test in order to get better signal level. Both horizontal and vertical polarizations of the antenna are set to make the measurement.
3. The EUT was placed on a turntable with 1.5m above ground.
4. The EUT was set 3 meters from the interference receiving antenna, which was mounted on the top of a variable height antenna tower.
5. For measurement above 1GHz, the emission measurement will be measured by the peak detector. This peak level, once corrected, must comply with the limit specified in Section 15.209.
6. For average power measurement, set the VBW to 10 Hz, while maintaining all of the other instrument settings, if the duty cycle of the EUT is less than 98%, the Duty Cycle Correction Factor shall be added to the measured emission levels. For the Duty Cycle and Correction Factor please refer to clause 6.1.ON TIME AND DUTY CYCLE.
8. For the actual test configuration, please refer to the related item in this test report (Photographs of the Test Configuration)

TEST CONDITIONS

9. For transmitters operating in the 5.725-5.85G GHz band: all emissions outside of the 5.725-5.85 GHz band shall not exceed an EIRP of -27 dBm/MHz.
 $-27 \text{ dBm/MHz Limit} = 95.2 + \text{EIRP}[\text{dBm}] = 95.2 - 27 = 68.2 \text{ dB}\mu\text{V/m}$

9. All antenna mode were test, the worst case is MIMO mode and the data recorded in this report.

Temperature: 25.6°C
 Relative Humidity: 59%
 Test Voltage: 7.4Vdc

6.6. RESTRICTED BANDEDGE

6.6.1. 802.11n HT 20 MODE

6.6.1.1. UNII-3 BAND

RESTRICTED BANDEDGE (LOW CHANNEL, HORIZONTAL)

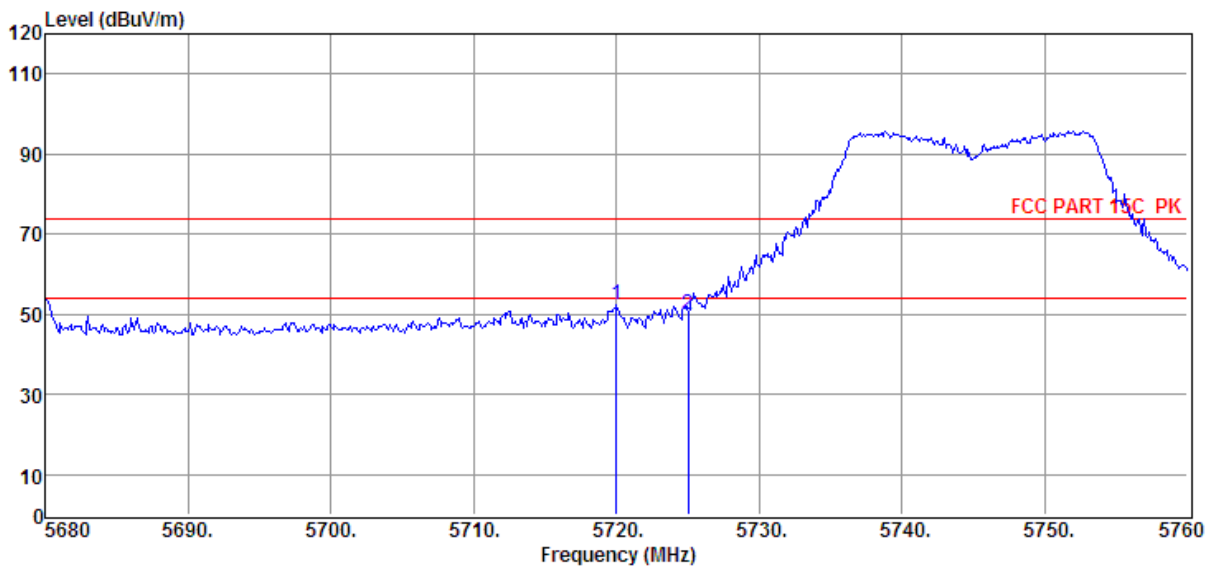

Item (Mark)	Freq. (MHz)	Read Level (dBμV)	Antenna Factor (dB/m)	PRM Factor dB	Cable Loss dB	Result Level (dBμV/m)	Limit Line (dBμV/m)	Over Limit (dB)	Detector	Polarization
1	5720.00	37.14	34.84	29.22	9.41	52.17	74.00	-21.83	Peak	HORIZONTAL
2	5725.00	34.74	34.84	29.22	9.41	49.77	74.00	-24.23	Peak	HORIZONTAL

- Note: 1. Result Level = Read Level + Antenna Factor + Cable loss - PRM Factor.
 2. If Peak Result complies with AV limit, AV Result is deemed to comply with AV limit.
 3. Test setup: RBW: 1 MHz, VBW: 3 MHz, Sweep time: auto.

RESTRICTED BANDEDGE (LOW CHANNEL, VERTICAL)

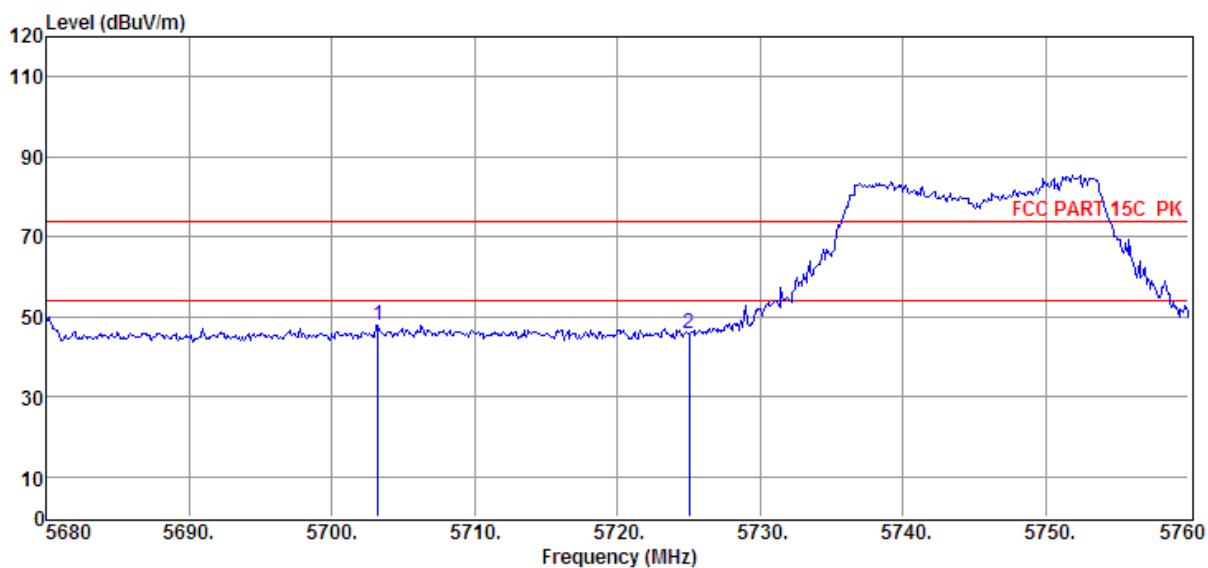

Item (Mark)	Freq. (MHz)	Read Level (dBμV)	Antenna Factor (dB/m)	PRM Factor (dB)	Cable Loss (dB)	Result Level (dBμV/m)	Limit Line (dBμV/m)	Over Limit (dB)	Detector	Polarization
1	5703.20	32.84	34.83	29.22	9.38	47.83	74.00	-26.17	Peak	VERTICAL
2	5725.00	30.92	34.84	29.22	9.41	45.95	74.00	-28.05	Peak	VERTICAL

- Note: 1. Result Level = Read Level + Antenna Factor + Cable loss - PRM Factor.
 2. If Peak Result complies with AV limit, AV Result is deemed to comply with AV limit.
 3. Test setup: RBW: 1 MHz, VBW: 3 MHz, Sweep time: auto.

RESTRICTED BANDEDGE (HIGH CHANNEL, HORIZONTAL)

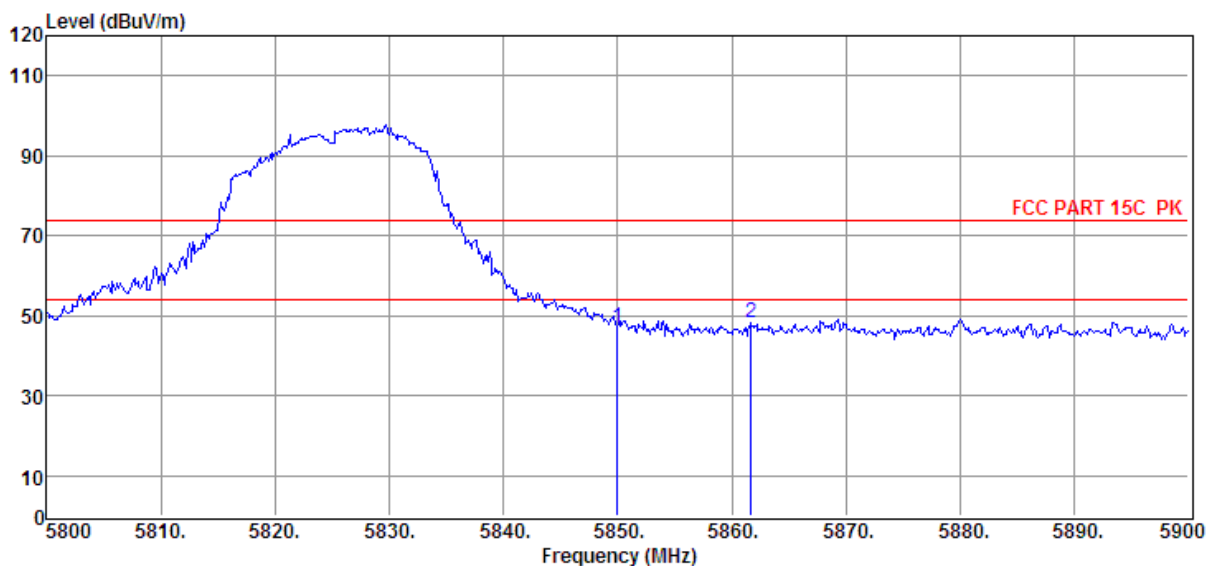

Item (Mark)	Freq. (MHz)	Read Level (dBμV)	Antenna Factor (dB/m)	PRM Factor (dB)	Cable Loss (dB)	Result Level (dBμV/m)	Limit Line (dBμV/m)	Over Limit (dB)	Detector	Polarization
1	5850.00	31.90	34.91	29.20	9.54	47.15	74.00	-26.85	Peak	HORIZONTAL
2	5861.70	32.80	34.92	29.20	9.56	48.08	74.00	-25.92	Peak	HORIZONTAL

Note: 1. Result Level = Read Level + Antenna Factor + Cable loss - PRM Factor.
 2. If Peak Result complies with AV limit, AV Result is deemed to comply with AV limit.
 3. Test setup: RBW: 1 MHz, VBW: 3 MHz, Sweep time: auto.

RESTRICTED BANDEDGE (LOW CHANNEL, VERTICAL)

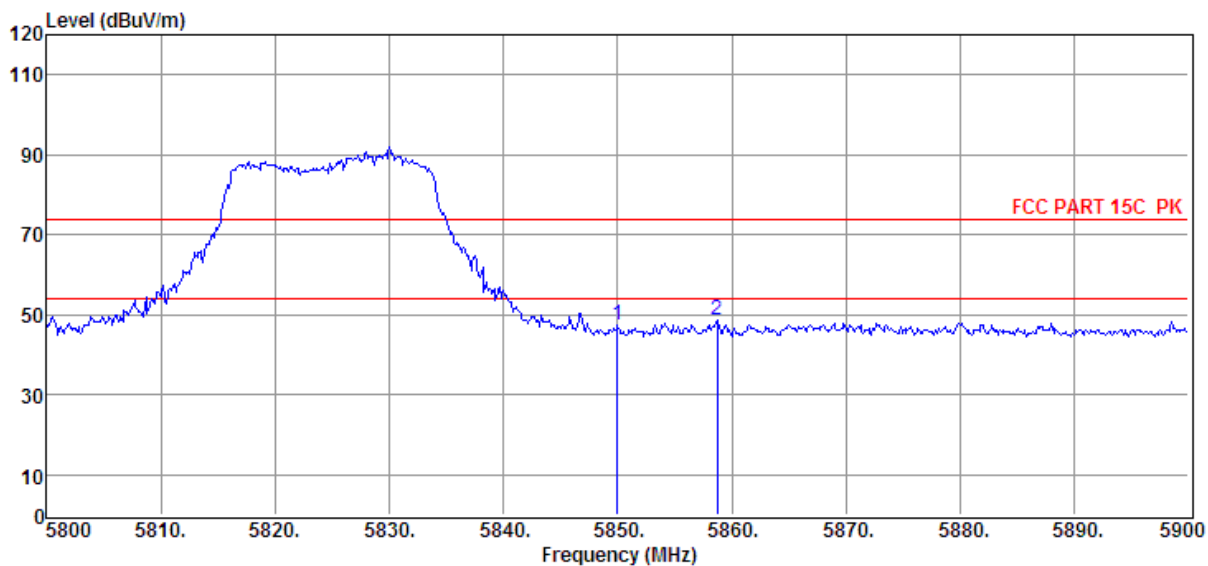

Item (Mark)	Freq. (MHz)	Read Level (dBμV)	Antenna Factor (dB/m)	PRM Factor dB	Cable Loss dB	Result Level (dBμV/m)	Limit Line (dBμV/m)	Over Limit (dB)	Detector	Polarization
1	5850.00	32.22	34.91	29.20	9.54	47.47	74.00	-26.53	Peak	VERTICAL
2	5858.70	33.46	34.92	29.20	9.54	48.72	74.00	-25.28	Peak	VERTICAL

- Note: 1. Result Level = Read Level + Antenna Factor + Cable loss - PRM Factor.
 2. If Peak Result complies with AV limit, AV Result is deemed to comply with AV limit.
 3. Test setup: RBW: 1 MHz, VBW: 3 MHz, Sweep time: auto.

6.7. SPURIOUS EMISSIONS (1~18GHz)

6.7.1. 802.11n HT 20 MODE

6.7.1.1. UNII-3 BAND

HARMONICS AND SPURIOUS EMISSIONS

EUT:	Transmitter for R/C Helicopter	Polarization :	Horizontal
Test Mode:	Low Chanel		

Item (Mark)	Freq. (MHz)	Read Level (dBμV)	Antenna Factor (dB/m)	PRM Factor dB	Cable Loss dB	Result Level (dBμV/m)	Limit Line (dBμV/m)	Over Limit (dB)	Detector	Polarization
1	6729.00	34.27	35.99	30.16	10.15	50.25	74.00	-23.75	Peak	HORIZONTAL
2	8191.00	36.48	36.16	31.29	11.33	52.68	74.00	-21.32	Peak	HORIZONTAL
3	9126.00	34.00	37.22	32.38	11.95	50.79	74.00	-23.21	Peak	HORIZONTAL
4	10299.00	33.38	36.60	33.09	12.59	49.48	74.00	-24.52	Peak	HORIZONTAL
5	11251.00	33.32	37.24	34.28	13.53	49.81	74.00	-24.19	Peak	HORIZONTAL
6	11795.00	34.55	37.24	34.70	13.95	51.04	74.00	-22.96	Peak	HORIZONTAL

- Note: 1. Result Level = Read Level + Antenna Factor + Cable loss - PRM Factor.
 2. If Peak Result complies with AV limit, AV Result is deemed to comply with AV limit.
 3. Test setup: RBW: 1 MHz, VBW: 3 MHz, Sweep time: auto.

EUT:	Transmitter for R/C Helicopter	Polarization :	Vertical
Test Mode:	Low Chanel		

Item (Mark)	Freq. (MHz)	Read Level (dBμV)	Antenna Factor (dB/m)	PRM Factor dB	Cable Loss dB	Result Level (dBμV/m)	Limit Line (dBμV/m)	Over Limit (dB)	Detector	Polarization
1	6814.00	33.60	36.05	30.25	10.26	49.66	74.00	-24.34	Peak	VERTICAL
2	7936.00	35.08	36.69	31.11	11.10	51.76	74.00	-22.24	Peak	VERTICAL
3	9755.00	35.47	36.66	32.82	12.40	51.71	74.00	-22.29	Peak	VERTICAL
4	11064.00	32.86	37.66	34.08	13.49	49.93	74.00	-24.07	Peak	VERTICAL
5	12560.00	33.65	38.36	35.31	14.64	51.34	74.00	-22.66	Peak	VERTICAL
6	13206.00	35.04	39.01	35.54	14.73	53.24	74.00	-20.76	Peak	VERTICAL

- Note: 1. Result Level = Read Level + Antenna Factor + Cable loss - PRM Factor.
 2. If Peak Result complies with AV limit, AV Result is deemed to comply with AV limit.
 3. Test setup: RBW: 1 MHz, VBW: 3 MHz, Sweep time: auto

EUT:	Transmitter for R/C Helicopter	Polarization :	Horizontal
Test Mode:	Middle Chanel		

Item (Mark)	Freq. (MHz)	Read Level (dBμV)	Antenna Factor (dB/m)	PRM Factor (dB)	Cable Loss (dB)	Result Level (dBμV/m)	Limit Line (dBμV/m)	Over Limit (dB)	Detector	Polarization
1	6746.00	34.09	36.00	30.18	10.19	50.10	74.00	-23.90	Peak	HORIZONTAL
2	8225.00	36.65	36.06	31.33	11.36	52.74	74.00	-21.26	Peak	HORIZONTAL
3	9041.00	33.95	37.41	32.34	11.87	50.89	74.00	-23.11	Peak	HORIZONTAL
4	9755.00	34.92	36.66	32.82	12.40	51.16	74.00	-22.84	Peak	HORIZONTAL
5	10809.00	34.30	37.27	33.64	13.19	51.12	74.00	-22.88	Peak	HORIZONTAL
6	12815.00	34.35	38.62	35.58	14.66	52.05	74.00	-21.95	Peak	HORIZONTAL

- Note: 1. Result Level = Read Level + Antenna Factor + Cable loss - PRM Factor.
 2. If Peak Result complies with AV limit, AV Result is deemed to comply with AV limit.
 3. Test setup: RBW: 1 MHz, VBW: 3 MHz, Sweep time: auto

EUT:	Transmitter for R/C Helicopter	Polarization :	Vertical
Test Mode:	Middle Chanel		

Item (Mark)	Freq. (MHz)	Read Level (dBμV)	Antenna Factor (dB/m)	PRM Factor (dB)	Cable Loss (dB)	Result Level (dBμV/m)	Limit Line (dBμV/m)	Over Limit (dB)	Detector	Polarization
1	6916.00	34.27	36.13	30.33	10.37	50.44	74.00	-23.56	Peak	VERTICAL
2	8004.00	34.32	36.69	31.13	11.13	51.01	74.00	-22.99	Peak	VERTICAL
3	9381.00	34.76	36.66	32.52	12.22	51.12	74.00	-22.88	Peak	VERTICAL
4	11336.00	33.25	37.06	34.38	13.55	49.48	74.00	-24.52	Peak	VERTICAL
5	12016.00	33.55	37.62	34.80	14.24	50.61	74.00	-23.39	Peak	VERTICAL
6	13444.00	34.81	39.24	35.28	14.78	53.55	74.00	-20.45	Peak	VERTICAL

- Note: 1. Result Level = Read Level + Antenna Factor + Cable loss - PRM Factor.
 2. If Peak Result complies with AV limit, AV Result is deemed to comply with AV limit.
 3. Test setup: RBW: 1 MHz, VBW: 3 MHz, Sweep time: auto

EUT:	Transmitter for R/C Helicopter	Polarization :	Horizontal
Test Mode:	High Chanel		

Item (Mark)	Freq. (MHz)	Read Level (dBμV)	Antenna Factor (dB/m)	PRM Factor dB	Cable Loss dB	Result Level (dBμV/m)	Limit Line (dBμV/m)	Over Limit (dB)	Detector	Polarization
1	8259.00	36.62	35.96	31.39	11.42	52.61	74.00	-21.39	Peak	HORIZONTAL
2	9041.00	34.72	37.41	32.34	11.87	51.66	74.00	-22.34	Peak	HORIZONTAL
3	9755.00	35.18	36.66	32.82	12.40	51.42	74.00	-22.58	Peak	HORIZONTAL
4	11285.00	33.20	37.17	34.35	13.54	49.56	74.00	-24.44	Peak	HORIZONTAL
5	12339.00	33.69	38.08	35.08	14.51	51.20	74.00	-22.80	Peak	HORIZONTAL
6	13376.00	34.96	39.18	35.38	14.76	53.52	74.00	-20.48	Peak	HORIZONTAL

Note: 1. Result Level = Read Level + Antenna Factor + Cable loss - PRM Factor.
 2. If Peak Result complies with AV limit, AV Result is deemed to comply with AV limit.
 3. Test setup: RBW: 1 MHz, VBW: 3 MHz, Sweep time: auto

EUT:	Transmitter for R/C Helicopter	Polarization :	Vertical
Test Mode:	High Chanel		

Item (Mark)	Freq. (MHz)	Read Level (dBμV)	Antenna Factor (dB/m)	PRM Factor dB	Cable Loss dB	Result Level (dBμV/m)	Limit Line (dBμV/m)	Over Limit (dB)	Detector	Polarization
1	7715.00	35.42	36.64	30.99	10.98	52.05	74.00	-21.95	Peak	VERTICAL
2	8769.00	35.09	36.50	32.15	11.73	51.17	74.00	-22.83	Peak	VERTICAL
3	9755.00	35.98	36.66	32.82	12.40	52.22	74.00	-21.78	Peak	VERTICAL
4	11115.00	33.35	37.54	34.13	13.50	50.26	74.00	-23.74	Peak	VERTICAL
5	12560.00	33.21	38.36	35.31	14.64	50.90	74.00	-23.10	Peak	VERTICAL
6	13444.00	34.66	39.24	35.28	14.78	53.40	74.00	-20.60	Peak	VERTICAL

Note: 1. Result Level = Read Level + Antenna Factor + Cable loss - PRM Factor.
 2. If Peak Result complies with AV limit, AV Result is deemed to comply with AV limit.
 3. Test setup: RBW: 1 MHz, VBW: 3 MHz, Sweep time: auto

6.8. SPURIOUS EMISSIONS BELOW 1 GHz

6.8.1. 802.11n HT20 MODE

EUT:	Transmitter for R/C Helicopter	Polarization :	Horizontal
Test Mode:	High Chanel		

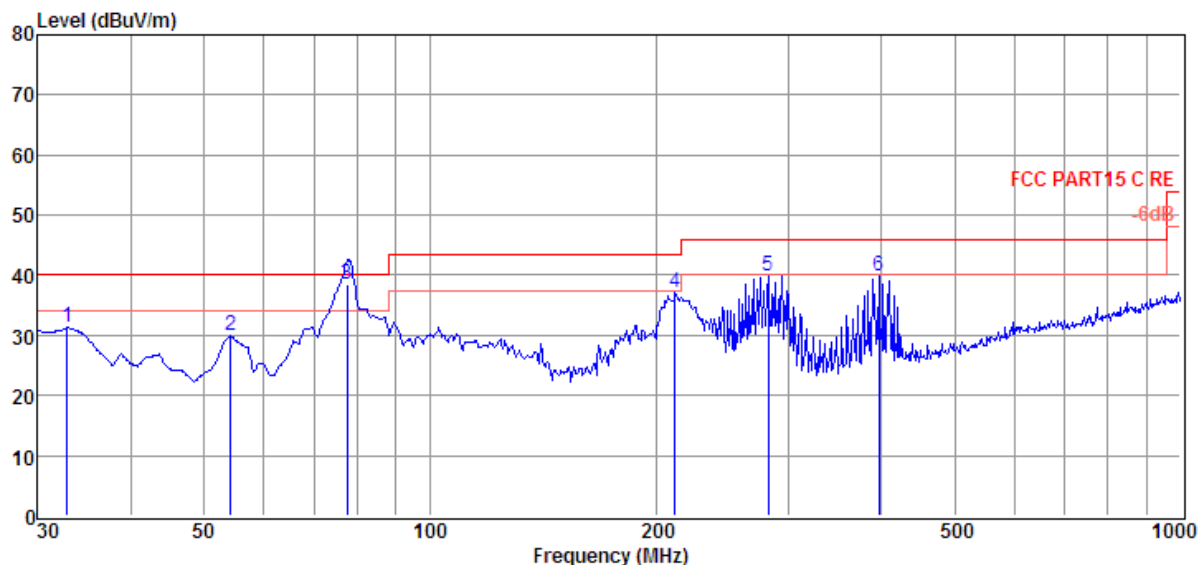

Item (Mark)	Freq. (MHz)	Read Level (dBuV)	Antenna Factor (dB/m)	PRM Factor dB	Cable Loss dB	Result Level (dBuV/m)	Limit Line (dBuV/m)	Over Limit (dB)	Detector	Polarization
1	32.86	16.06	11.49	0.00	3.71	31.26	40.00	-8.74	Peak	HORIZONTAL
2	54.26	14.22	11.69	0.00	3.93	29.84	40.00	-10.16	Peak	HORIZONTAL
3	77.59	27.60	6.87	0.00	4.13	38.60	40.00	-1.40	QP	HORIZONTAL
4	212.27	21.17	10.89	0.00	4.96	37.02	43.50	-6.48	Peak	HORIZONTAL
5	282.00	21.82	12.72	0.00	5.29	39.83	46.00	-6.17	Peak	HORIZONTAL
6	396.24	18.33	15.63	0.00	5.78	39.74	46.00	-6.26	Peak	HORIZONTAL

Note: 1. Result Level = Read Level + Antenna Factor + Cable loss - PRM Factor.
 2. If Peak Result complies with AV limit, AV Result is deemed to comply with AV limit.
 3. Test setup: RBW: 1 MHz, VBW: 3 MHz, Sweep time: auto.

EUT:	Transmitter for R/C Helicopter	Polarization :	Vertical
Test Mode:	High Chanel		

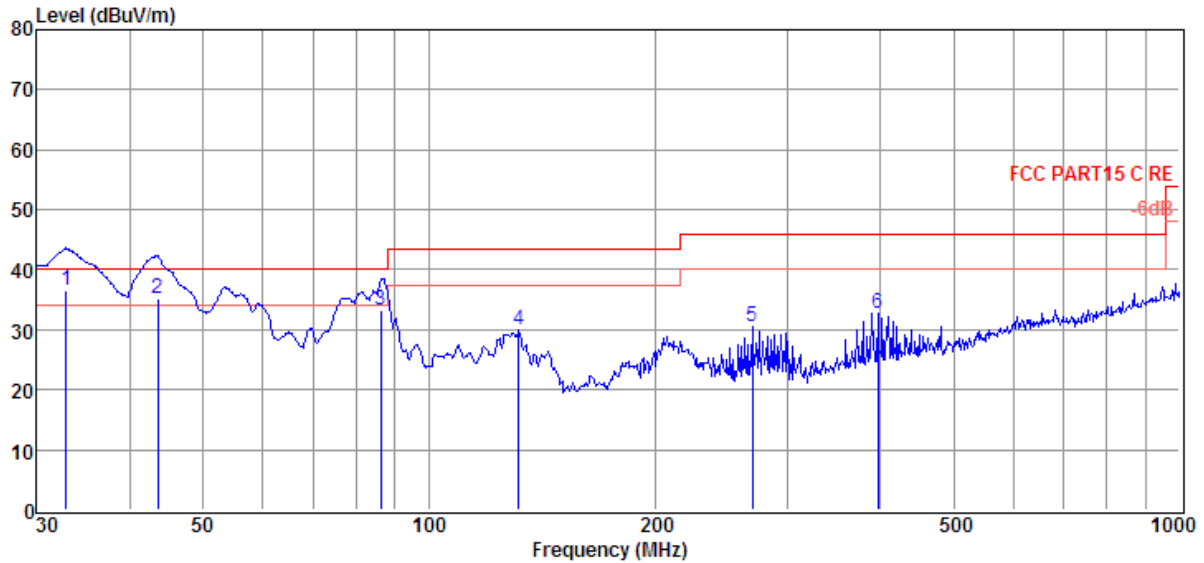

Item (Mark)	Freq. (MHz)	Read Level (dBμV)	Antenna Factor (dB/m)	PRM Factor dB	Cable Loss dB	Result Level (dBμV/m)	Limit Line (dBμV/m)	Over Limit (dB)	Detector	Polarization
1	32.86	21.29	11.49	0.00	3.71	36.49	40.00	-3.51	QP	VERTICAL
2	43.51	19.08	12.42	0.00	3.82	35.32	40.00	-4.68	QP	VERTICAL
3	86.20	19.77	9.42	0.00	4.19	33.38	40.00	-6.62	QP	VERTICAL
4	131.76	17.76	7.83	0.00	4.49	30.08	43.50	-13.42	Peak	VERTICAL
5	269.43	12.45	12.87	0.00	5.23	30.55	46.00	-15.45	Peak	VERTICAL
6	396.24	11.17	15.63	0.00	5.78	32.58	46.00	-13.42	Peak	VERTICAL

- Note: 1. Result Level = Read Level + Antenna Factor + Cable loss - PRM Factor.
 2. If Peak Result complies with AV limit, AV Result is deemed to comply with AV limit.
 3. Test setup: RBW: 1 MHz, VBW: 3 MHz, Sweep time: auto.

Note 1: All the modulation and channels had been tested, but only the worst data recorded in the report.

Note 2: EUT in each of three orthogonal axis emissions had been tested, but only the worst case (X axis) data recorded in the report.

6.9. SPURIOUS EMISSIONS BELOW 30M

Note: The low frequency, which started from 9 kHz to 30MHz, was pre-scanned and the result which was 20dB lower than the limit line per 15.31(o) was not reported.

7. AC POWER LINE CONDUCTED EMISSIONS

LIMITS

Please refer to FCC §15.207 (a)

FREQUENCY (MHz)	Class A (dBuV)		Class B (dBuV)	
	Quasi-peak	Average	Quasi-peak	Average
0.15 -0.5	79.00	66.00	66 - 56 *	56 - 46 *
0.50 -5.0	73.00	60.00	56.00	46.00
5.0 -30.0	73.00	60.00	60.00	50.00

TEST SETUP AND PROCEDURE

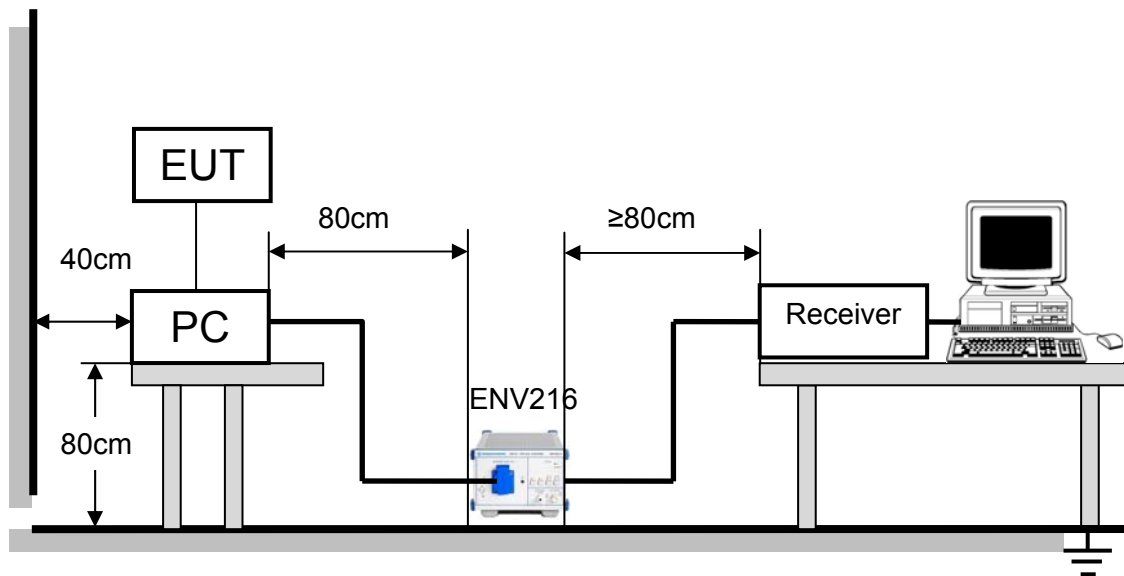

The EUT is put on a table of non-conducting material that is 80cm high. The vertical conducting wall of shielding is located 40cm to the rear of the EUT. The power line of the EUT is connected to the AC mains through a Artificial Mains Network (A.M.N.). A EMI Measurement Receiver (R&S Test Receiver ESR3) is used to test the emissions from both sides of AC line. According to the requirements in Section 7 and 13 of ANSI C63.10-2013. Conducted emissions from the EUT measured in the frequency range between 0.15 MHz and 30MHz using CISPR Quasi-Peak and average detector mode. The bandwidth of EMI test receiver is set at 9kHz.

The arrangement of the equipment is installed to meet the standards and operating in a manner, which tends to maximize its emission characteristics in a normal application.

TEST CONDITIONS

Temperature: 24.6°C
 Relative Humidity: 58%
 Test Voltage: 7.4Vdc

TEST RESULTS (WORST-CASE CONFIGURATION)

EUT:	Transmitter for R/C Helicopter	Phase :	L
Test Mode:	UNII-1 BAND Middle Channel		

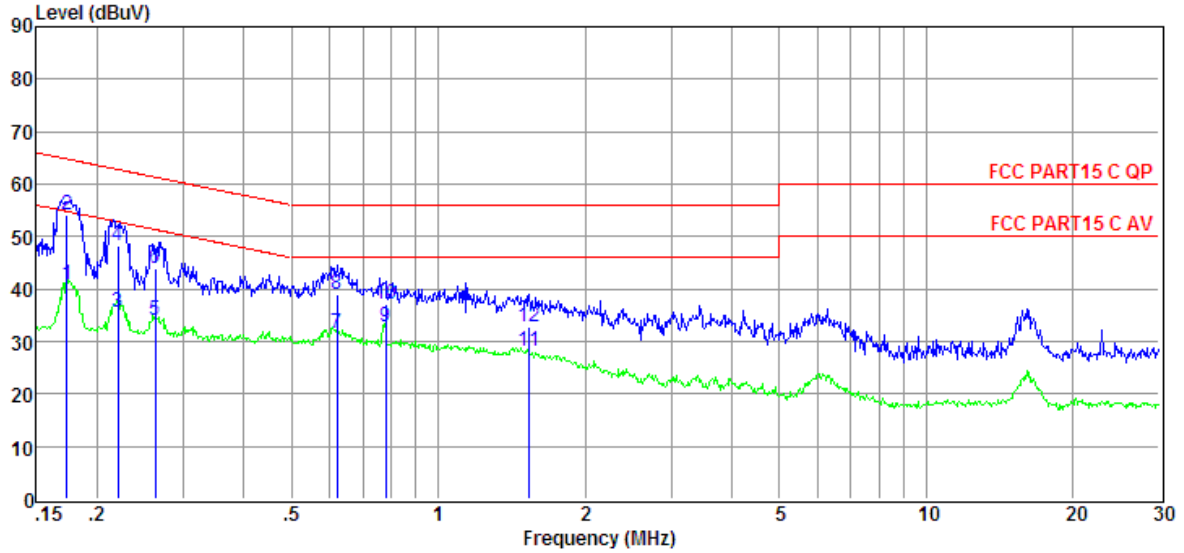

Item (Mark)	Freq. (MHz)	Read Level (dBμV)	LISN Factor (dB)	Cable Loss (dB)	Pulse Limiter Factor (dB)	Result Level (dBμV)	Limit Line (dBμV)	Over Limit (dB)	Detector	Phase
1	0.17	21.27	9.61	0.02	9.86	40.76	54.81	-14.05	Average	LINE
2	0.17	34.58	9.61	0.02	9.86	54.07	64.81	-10.74	QP	LINE
3	0.22	16.19	9.61	0.02	9.86	35.68	52.79	-17.11	Average	LINE
4	0.22	28.62	9.61	0.02	9.86	48.11	62.79	-14.68	QP	LINE
5	0.26	14.39	9.61	0.02	9.86	33.88	51.34	-17.46	Average	LINE
6	0.26	24.41	9.61	0.02	9.86	43.90	61.34	-17.44	QP	LINE
7	0.62	12.02	9.61	0.03	9.86	31.52	46.00	-14.48	Average	LINE
8	0.62	19.35	9.61	0.03	9.86	38.85	56.00	-17.15	QP	LINE
9	0.78	13.37	9.61	0.03	9.86	32.87	46.00	-13.13	Average	LINE
10	0.78	17.67	9.61	0.03	9.86	37.17	56.00	-18.83	QP	LINE
11	1.54	8.50	9.62	0.04	9.86	28.02	46.00	-17.98	Average	LINE
12	1.54	13.33	9.62	0.04	9.86	32.85	56.00	-23.15	QP	LINE

- Note: 1. Result Level = Read Level + LISN Factor + Pulse Limiter Factor + Cable loss.
 2. If QP Result complies with AV limit, AV Result is deemed to comply with AV limit.
 3. Test setup: RBW: 200 Hz (9 kHz—150 kHz), 9 kHz (150 kHz—30 MHz).
 4. Step size: 80Hz (0.009MHz-0.15MHz), 4 kHz (0.15MHz-30MHz), Scan time: auto.

EUT:	Transmitter for R/C Helicopter	Phase :	N
Test Mode:			

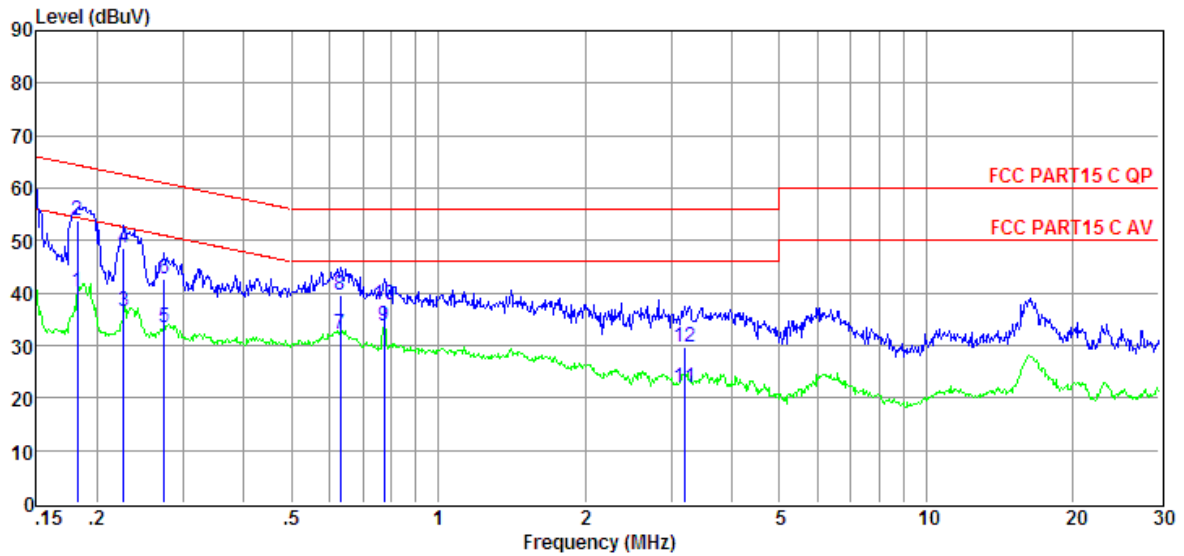

Item (Mark)	Freq. (MHz)	Read Level (dBμV)	LISN Factor (dB)	Cable Loss (dB)	Pulse Limiter Factor (dB)	Result Level (dBμV)	Limit Line (dBμV)	Over Limit (dB)	Detector	Phase
1	0.18	20.79	9.61	0.02	9.86	40.28	54.37	-14.09	Average	NEUTRAL
2	0.18	34.20	9.61	0.02	9.86	53.69	64.37	-10.68	QP	NEUTRAL
3	0.23	17.06	9.61	0.02	9.86	36.55	52.57	-16.02	Average	NEUTRAL
4	0.23	29.03	9.61	0.02	9.86	48.52	62.57	-14.05	QP	NEUTRAL
5	0.27	13.84	9.61	0.02	9.86	33.33	50.98	-17.65	Average	NEUTRAL
6	0.27	23.23	9.61	0.02	9.86	42.72	60.98	-18.26	QP	NEUTRAL
7	0.63	12.77	9.61	0.03	9.86	32.27	46.00	-13.73	Average	NEUTRAL
8	0.63	20.06	9.61	0.03	9.86	39.56	56.00	-16.44	QP	NEUTRAL
9	0.78	14.09	9.61	0.03	9.86	33.59	46.00	-12.41	Average	NEUTRAL
10	0.78	18.13	9.61	0.03	9.86	37.63	56.00	-18.37	QP	NEUTRAL
11	3.21	2.47	9.64	0.05	9.87	22.03	46.00	-23.97	Average	NEUTRAL
12	3.21	10.19	9.64	0.05	9.87	29.75	56.00	-26.25	QP	NEUTRAL

- Note: 1. Result Level = Read Level + LISN Factor + Pulse Limiter Factor + Cable loss.
 2. If QP Result complies with AV limit, AV Result is deemed to comply with AV limit.
 3. Test setup: RBW: 200 Hz (9 kHz—150 kHz), 9 kHz (150 kHz—30 MHz).
 4. Step size: 80Hz (0.009MHz-0.15MHz), 4 kHz (0.15MHz-30MHz), Scan time: auto.

Note: All the modulation and channels had been tested, but only the worst data recorded in the report.

8. FREQUENCY STABILITY

LIMITS

FCC Part15, Subpart E		
Test Item	Limit	Frequency Range (MHz)
Frequency Stability	Specified in the user's manual	5745-5825

TEST SETUP AND PROCEDURE

Connect the UUT to the spectrum analyser and use the following settings:

Center Frequency	The centre frequency of the channel under test
Detector	PEAK
RBW	10KHz
VBW	$\geq 3 \times \text{RBW}$
Span	Encompass the entire emissions bandwidth (EBW) of the signal
Trace	Max hold
Sweep time	Auto

Allow the trace to stabilize, find the peak value of the power envelope and record the frequency, then calculated the frequency drift.

The test extreme voltage is to change the primary supply voltage from 85 to 115 percent of the nominal value.

User manual temperature is $-20^{\circ}\text{C} \sim 35^{\circ}\text{C}$.

TEST SETUP

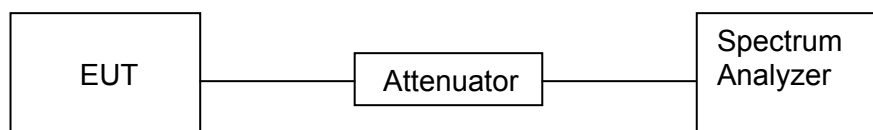

TEST CONDITIONS

Temperature: 24.6°C
 Relative Humidity: 58%
 Test Voltage: 7.4Vdc

TEST RESULTS (WORST-CASE CONFIGURATION)

EUT:	Transmitter for R/C Helicopter	Test Mode:	802.11n HT20 MODE
------	--------------------------------	------------	-------------------

Frequency Error vs. Voltage:

Test Mode	Antenna	Channel	Temp.	Volt.	Freq.Error(MHz)	Freq.vs.rated(ppm)	Verdict
11N20	Ant1	5745	TN	VL	5744.90	-17.41	PASS
			TN	VN	5744.91	-15.67	PASS
			TN	VH	5744.91	-15.67	PASS
11N20	Ant1	5825	TN	VL	5824.93	-12.02	PASS
			TN	VN	5824.94	-10.30	PASS
			TN	VH	5824.93	-12.02	PASS
11N20	Ant2	5745	TN	VL	5744.93	-12.18	PASS
			TN	VN	5744.94	-10.44	PASS
			TN	VH	5744.94	-10.44	PASS
11N20	Ant2	5825	TN	VL	5824.90	-17.17	PASS
			TN	VN	5824.90	-17.17	PASS
			TN	VH	5824.91	-15.45	PASS

Frequency Error vs. Temperature:

Test Mode	Antenna	Channel	Temp.	Volt.	Freq.Error(MHz)	Freq.vs.rated(ppm)	Verdict
11N20	Ant1	5745	50	VN	5744.91	-15.67	PASS
			40	VN	5744.91	-15.67	PASS
			30	VN	5744.90	-17.41	PASS
			20	VN	5744.91	-15.67	PASS
			10	VN	5744.90	-17.41	PASS
			0	VN	5744.93	-12.18	PASS
			-10	VN	5744.91	-15.67	PASS
			-20	VN	5744.93	-12.18	PASS
			-30	VN	5744.91	-15.67	PASS
11N20	Ant1	5825	50	VN	5824.93	-12.02	PASS
			40	VN	5824.93	-12.02	PASS
			30	VN	5824.94	-10.30	PASS
			20	VN	5824.91	-15.45	PASS
			10	VN	5824.90	-17.17	PASS

			0	VN	5824.91	-15.45	PASS
			-10	VN	5824.90	-17.17	PASS
			-20	VN	5824.91	-15.45	PASS
			-30	VN	5824.91	-15.45	PASS
11N20	Ant2	5745	50	VN	5744.94	-10.44	PASS
			40	VN	5744.94	-10.44	PASS
			30	VN	5744.99	-1.74	PASS
			20	VN	5744.96	-6.96	PASS
			10	VN	5744.96	-6.96	PASS
			0	VN	5744.94	-10.44	PASS
			-10	VN	5744.96	-6.96	PASS
			-20	VN	5744.96	-6.96	PASS
			-30	VN	5744.96	-6.96	PASS
11N20	Ant2	5825	50	VN	5824.91	-15.45	PASS
			40	VN	5824.90	-17.17	PASS
			30	VN	5824.90	-17.17	PASS
			20	VN	5824.90	-17.17	PASS
			10	VN	5824.91	-15.45	PASS
			0	VN	5824.90	-17.17	PASS
			-10	VN	5824.90	-17.17	PASS
			-20	VN	5824.91	-15.45	PASS
			-30	VN	5824.90	-17.17	PASS

Note 1: All the modulation and channels had been tested, but only the worst data recorded in the report.

9. ANTENNA REQUIREMENTS

APPLICABLE REQUIREMENTS

Please refer to FCC §15.203

An intentional radiator shall be designed to ensure that no antenna other than that furnished by the responsible party shall be used with the device. The use of a permanently attached antenna or of an antenna that uses a unique coupling to the intentional radiator shall be considered sufficient to comply with the provisions of this section. The manufacturer may design the unit so that a broken antenna can be replaced by the user, but the use of a standard antenna jack or electrical connector is prohibited.

Please refer to FCC §15.247(b)(4)

The conducted output power limit specified in paragraph (b) of this section is based on the use of antennas with directional gains that do not exceed 6 dBi. Except as shown in paragraph (c) of this section, if transmitting antennas of directional gain greater than 6 dBi are used, the conducted output power from the intentional radiator shall be reduced below the stated values in paragraphs (b)(1), (b)(2), and (b)(3) of this section, as appropriate, by the amount in dB that the directional gain of the antenna exceeds 6 dBi.

ANTENNA CONNECTOR

Antenna Connector is on the PCB within enclosure and not accessible to user.

ANTENNA GAIN

The antenna gain of EUT is less than 6 dBi.

END OF REPORT